

Version 3.1

February 2021

Xerox[®] VersaLink[®] B600/B610 Printer

Xerox[®] VersaLink[®] B605/B615
Multifunction Printer

Customer Expectation and Installation Guide

©2017 Xerox Corporation. All rights reserved. Unpublished rights reserved under the copyright laws of the United States. Contents of this publication may not be reproduced in any form without permission of Xerox Corporation.

Copyright protection claimed includes all forms of matters of copyrightable materials and information now allowed by statutory or judicial law or hereinafter granted, including without limitation, material generated from the software programs which are displayed on the screen such as styles, templates, icons, screen displays, looks, and so on.

Xerox® and Xerox and Design®, Xerox Extensible Interface Platform®, ConnectKey®, Global Print Driver®, Mobile Express Driver® and VersaLink® are trademarks of Xerox Corporation in the United States and/or other countries.

BR22177

Product Overview

Introduction

This document is intended to help you understand the performance and capabilities of the Xerox® VersaLink B600/B610 and Xerox® VersaLink B605/B615, including information on optional accessories. Installation planning information is provided later in this document and it contains specifications and guidelines for installing your device. Specifications and data in this document include Xerox and customer proprietary information. The customer will use all reasonable efforts to safeguard the document, will not disclose its contents to third parties, and should only circulate it within the organization on a need-to-know basis.

Product Highlights

The compact VersaLink B600/B610/B605/B615 excels in small office environments where high-impact speed, and ease of use are important.

Convenience

- Compact designs fit in tight busy spaces
- Built-in Wi-Fi enabled through USB port allows untethered mobility with new Wi-Fi installation wizard and WPS setup
- Optional Fax (MFP only)
- Wi-Fi Direct®
- NFC Tap-to-Pair
- Apple® AirPrint 1.5
- Mopria® 1.2

Performance

- Up to 58 ppm for VersaLink B600/B605
- Up to 65 ppm for VersaLink B610/B615
- Dual head single pass scanner (MFP only)
- Large 550-sheet paper tray
- Hefty processing power with generous amount of standard memory
- Outstanding output image quality

Ease

- Large 5-inch color capacitive touchscreen (swipe) interface for VersaLink B600 and B610 Printers and large 7-inch color capacitive touchscreen for VersaLink B605 and B615 Multifunction Printers.
- Scan to Email
- Scan to and Print from USB at the device
- Xerox App Gallery app for easy access to downloadable apps
- Optional 2,000-sheet High Capacity Feeder
- Optional finisher and mailbox accessories for VersaLink B605/B615 (Tall)

System / Product Configurations

Each version of the product will be available in the following configurations. The VersaLink B600/B610 will be available in the printer only configuration at 58/65 ppm. The VersaLink B605/B615 will be available in 58/65 ppm multifunction printer configurations. Both configurations will be available as duplex.

VersaLink B600/B610 Printer



VersaLink B605/B615 Multifunction Printer



Detailed Specifications and Product Brochure

Xerox® VersaLink® B600 Printer and B605 Multifunction Printer Brochure

[Xerox VersaLink B600 Printer and Xerox VersaLink B605 Multifunction Printer Brochure](#)

Xerox® VersaLink® B610 Printer Brochure

[Xerox VersaLink B610 Printer Brochure](#)

Xerox® VersaLink® B615 Multifunction Printer Product Brochure

[Xerox VersaLink B615 Multifunction Printer Brochure](#)

VersaLink B600 Printer – Detailed Specification Sheet

[Xerox® VersaLink® B600 Printer](#)

VersaLink B610 Printer – Detailed Specification Sheet

[Xerox® VersaLink® B610 Printer](#)

Versalink B605 Multifunction Printer – Detailed Specification Sheet

[Xerox® VersaLink® B605 Multifunction Printer](#)

Versalink B615 Multifunction Printer – Detailed Specification Sheet

[Xerox® VersaLink B615 Multifunction Printer](#)

Maintenance and Support

Customer/Operator Maintenance

Support Services

The majority of service related issues can be resolved by the customer using the Xerox Online Support tools from the device driver resident on the computer, or through the device Embedded Web Server page. To supplement the Xerox Online Support experience, knowledgeable support resources will be available via the phone. The phone support resources typically resolve issues on the first call. For issues that cannot be resolved over the phone, customers will typically receive onsite field service the following day from a combination of Xerox Employees and Xerox Authorized National Service Providers. In addition to onboard, driver based customer tools, telephone and on-site service, customers will also have access to web technical support: www.xerox.com/officeprinting/support/.

Product Sustainability

Packaging Take-Back Service for Xerox® branded products: (U.S. only) Whenever possible, Xerox encourages you to recycle packaging locally as it reduces greenhouse gas emissions associated with transportation. However, if unable to recycle locally, we offer a packaging take-back and recycling service to our customers for Xerox® branded products, where customers pay for the return shipping and Xerox pays for the recycling. If interested in this service, please send your packaging to: Xerox Corporation, ESSO – Scrap, 6500 State Route 63, Middletown, OH 45044, Attention: EPEAT Packaging Returns.

Consumables for this product are part of the Xerox Green World Alliance Supplies Recycling Program. For more information, please visit the Green World Alliance website at www.xerox.com/gwa.

Supplies and Consumables

Xerox supplies for your machine, including paper and CRUs, can be ordered from Xerox by going to www.xerox.com and clicking on either the Contact Us link for specific contact information/telephone numbers in your area or by clicking on the Supplies and entering/selecting your specific machine information (product family and model type).

Note: Always refer to www.xerox.com for the latest Customer Replaceable Units (CRUs) part numbers.

Recommended Toner Supplies

Item	Description/Yield	Part Order#
Toner Cartridge – Metered	49,400 pages ⁵	106R03946
Toner Cartridge – Standard Capacity (North America and Europe)	10,300 pages ⁴	106R03940
Toner Cartridge – Standard Capacity (DMO)	10,300 pages ⁴	106R03941
Toner Cartridge – High Capacity (North America and Europe)	25,900 pages ⁴	106R03942
Toner Cartridge – High Capacity (DMO)	25,900 pages ⁴	106R03943
Toner Cartridge – Extra High Capacity (North America and Europe)	46,700 pages ⁴	106R03944
Toner Cartridge – Extra High Capacity (DMO)	46,700 pages ⁴	106R03945
Toner Cartridge – Starter	10,300 pages ⁴	106R03947
Drum Cartridge	60,000 pages ⁵	101R00582
Drum Cartridge – Starter	60,000 pages ⁵	101R00583

⁴ Average standard pages. Declared Yield in accordance with ISO/IEC 19752. Yield will vary based on image, area coverage and print mode.

⁵ Approximate pages. Declared yield will vary depending on job run length, media size/orientation and machine speed. For more information visit: <http://www.office.xerox.com/latest/SUPGL-01.pdf>.

Note:

Frequency of supplies replenishment for printing and periodic maintenance will vary depending on monthly print volume, type of maintenance contract, and applications. Check with your supplies help desk for details

Installation Preparation

Roles and Responsibilities

This section is key to clearly state Xerox/Partner and the customer roles and responsibilities and necessary actions.

Responsibility Matrix

Action	Customer	Xerox/Partner
Ensure adequate space and power to install system	X	
Ensure Site survey is completed and the size requirements are communicated to the customer.		X
Unpack system / components	X	
Install system hardware	X	
Connect all System Components prior to powering up the system	X	
Ensure network configuration	X	
Confirm network integrity	X	
Acquire and install client software including print drivers	X	
Run initial software diagnostics when directed	X	
Monitor and adjust as required	X	
Load any additional fonts	X	
Order and replace Customer Replaceable Units as needed.	X	
Provide Help Line support		X
Provide spared parts		X

Installation Planning

Dimensions and Weights (Unpackaged)				
Configuration ¹	Width	Depth	Height	Weight
SFP	16.8 in. / 427.4 mm	18.3 in. / 465.5 mm	17.5 in. / 443.4 mm	49.2 lbs. / 22.3 kg
MFP (short type)	18.5 in. / 470 mm	19.8 in. / 502.8 mm	25.3 in. / 643.7 mm	67.2 lbs. / 30.5 kg
MFP (tall type)	18.5 in. / 470 mm	19.8 in. / 502.8 mm	33.3 in. / 843.7 mm	71.7 lbs. / 32.5 kg
550 sheet tray	16.5 in. / 420 mm	10.4 in. / 464.5 mm	4.8 in. / 123 mm	14.6 lbs. / 6.6 kg
HCF	28.5 in. / 724.2 mm	30.4 in. / 772.1 mm	18 in. / 459 mm	43.3 lbs. / 19.7 kg
Stand	28.5 in. / 724.2 mm	30.4 in. / 772.1 mm	13.2 in. / 336 mm	37 lbs. / 16.6 kg
Casters	28.5 in. / 724.2 mm	30.4 in. / 772.1 mm	3.5 in. / 90 mm	18.7 lbs. / 8.5 kg
Mailbox	17.7 in. / 450.8 mm	18.8 in. / 477.6 mm	9.8 in. / 248.0 mm	11.7 lbs. / 5.3 kg
Finisher	17.7 in. / 450.8 mm	16.2 in. / 411.0 mm	9.8 in. / 248.0 mm	15 lbs. / 6.8 kg
B600/610DN	16.8 in. / 427.4 mm	18.3 in. / 465.5 mm	17.5 in. / 443.4 mm	49.2 lbs. / 22.3 kg
B600/610DT	16.8 in. / 427.4 mm	18.3 in. / 465.5 mm	22.3 in. / 566.4 mm	63.8 lbs. / 28.9 kg
B600/610DX	16.8 in. / 427.4 mm	18.3 in. / 465.5 mm	35.5 in. / 902.4 mm	92.5 lbs. / 42 kg
B600/610DXF	16.8 in. / 427.4 mm	18.3 in. / 465.5 mm	45.3 in. / 1150.4 mm	107.5 lbs. / 48.8 kg
B600/610DXP	16.8 in. / 427.4 mm	18.3 in. / 465.5 mm	45.3 in. / 1150.4 mm	104.2 lbs. / 47.3 kg
B605S/X	18.5 in. / 470 mm	19.8 in. / 502.8 mm	25.3 in. / 643.7 mm	67.2 lbs. / 30.5 kg
B605SF/XF	18.5 in. / 470 mm	19.8 in. / 502.8 mm	33.3 in. / 843.7 mm	86.7 lbs. / 39.3 kg
B605SP/XP	18.5 in. / 470 mm	19.8 in. / 502.8 mm	33.3 in. / 843.7 mm	83.4 lbs. / 37.8 kg
B605/615XTF	18.5 in. / 470 mm	19.8 in. / 502.8 mm	56.1 in. / 1425.7mm	144.6 lbs. / 65.6 kg
B615X	18.5 in. / 470 mm	19.8 in. / 502.8 mm	25.3 in. / 643.7 mm	67.2 lbs. / 30.5 kg

Dimensions and Weights (Unpackaged)				
Configuration ¹	Width	Depth	Height	Weight
B615SF/XF	18.5 in. / 470 mm	19.8 in. / 502.8 mm	33.3 in. / 843.7 mm	86.7 lbs. / 39.3 kg
B615SP/XP	18.5 in. / 470 mm	19.8 in. / 502.8 mm	33.3 in. / 843.7 mm	83.4 lbs. / 37.8 kg
B615XTP	18.5 in. / 470 mm	19.8 in. / 502.8 mm	56.1 in. / 1425.7mm	141.3 lbs. / 64 kg

Dimensions and Weights (Packaged)				
Configuration ¹	Width	Depth	Height	Weight
SFP (short type)	22.8 in / 580 mm	25 in / 634 mm	23.9 in / 607 mm	61.6 lb / 28 kg
MFP (short type)	23.4 in / 594 mm	25.8 in / 655 mm	31.1 in / 789 mm	83.8 lb / 38 kg
MFP (tall type)	23.4 in / 594 mm	25.8 in / 655 mm	39.2 in / 996 mm	94.8 lb / 43 kg
550 sheet tray	21 in / 535 mm	23 in / 584 mm	9.8 in / 248 mm	18.7 lb / 8.5 kg
HCF	22.4 in / 568 mm	26.1 in / 663 mm	28 in / 711 mm	79.4 lb / 38 kg
Stand	23 in / 584 mm	24.8 in / 629 mm	23.5 in / 597 mm	57.3 lb / 28 kg
Casters	23 in / 585 mm	24.4 in / 619 mm	13 in / 330 mm	39.7 lb / 18 kg
Mailbox	22.6 in / 573 mm	20.4 in / 518 mm	15.2 in / 386 mm	16.3 lb / 7.8 kg
Finisher	22.6 in / 573 mm	15.7 in / 398 mm	15.2 in / 386 mm	18.6 lb / 8.8 kg
Wi-Fi Dongle	7.4 in / 188 mm	5.4 in / 136 mm	2.2 in / 55 mm	1.05 lb / .1 kg
HDD	4.5 in / 116 mm	1.8 in / 46 mm	7 in / 178 mm	.4 lb / .18 kg
B600/610DN	22.8 in / 580 mm	25 in / 634 mm	23.9 in / 607 mm	61.6 lb / 28 kg
B600/610DT	25 in. / 635 mm	27 in. / 685.8 mm	48 in. / 1219.2 mm	120.34 lbs. / 54.7 kg
B600/610DX	28 in. / 711.2 mm	48.5 in. / 1231.9 mm	51 in. / 1295.4 mm	190.3 lbs. / 86.5 kg
B600/610DXF	28 in. / 711.2 mm	48.5 in. / 1231.9 mm	51 in. / 1295.4 mm	209.5 lbs. / 95.2 kg
B600/610DXP	28 in. / 711.2 mm	48.5 in. / 1231.9 mm	51 in. / 1295.4 mm	207.5 lbs. / 94.3 kg
B605S/X	23.4 in / 594 mm	25.8 in / 655 mm	31.1 in / 789 mm	83.8 lb / 38 kg
B605SF/XF	27 in. / 685.8 mm	47.5 in. / 1206.5 mm	51 in. / 1295.4 mm	158.9 lbs. / 72.2 kg
B605SP/XP	27 in. / 685.8 mm	47.5 in. / 1206.5 mm	51 in. / 1295.4 mm	156.9 lbs. / 71.3 kg
B605/615XTF	27 in. / 685.8 mm	47.5 in. / 1206.5 mm	51 in. / 1295.4 mm	242.5 lbs. / 110.2 kg
B615X	23.4 in / 594 mm	25.8 in / 655 mm	31.1 in / 789 mm	83.8 lb / 38 kg
B615SF/XF	27 in. / 685.8 mm	47.5 in. / 1206.5 mm	51 in. / 1295.4 mm	158.8 lbs. / 72.2 kg
B615SP/XP	27 in. / 685.8 mm	47.5 in. / 1206.5 mm	51 in. / 1295.4 mm	156.9 lbs. / 71.3 kg
B615XTP	27 in. / 685.8 mm	47.5 in. / 1206.5 mm	51 in. / 1295.4 mm	240.5 lbs. / 109.3 kg

¹Not all configurations available in all geographies

Installation Planning

Xerox® VersaLink® B600/B610 Install Space:

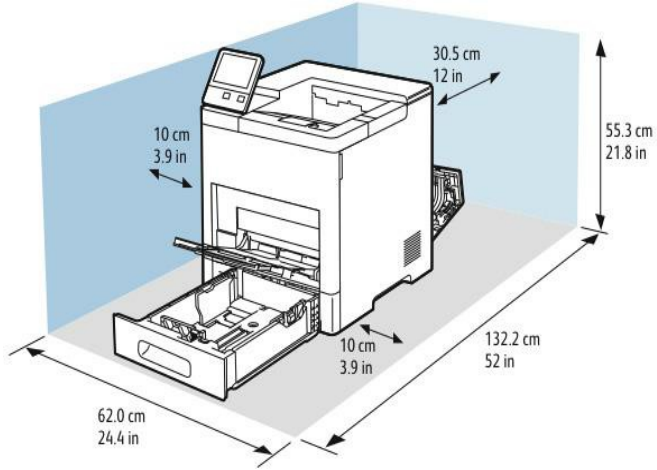

Xerox® VersaLink® B605/B615 Install Space:

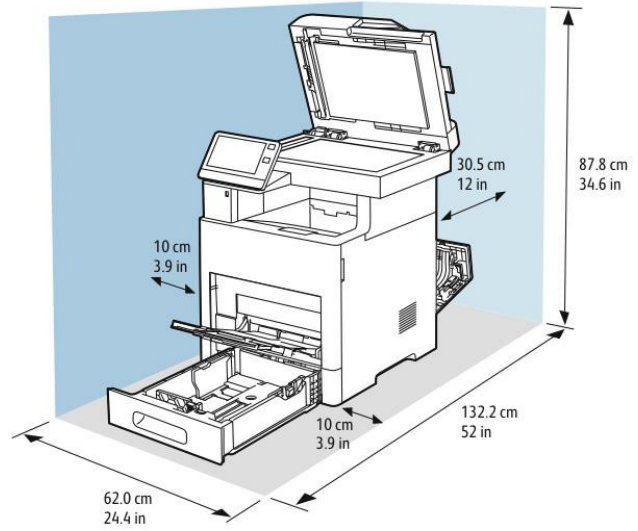

Appendix

Customer Expectations Agreement

I have reviewed and understand the product expectations and installation preparation requirements, as referenced in this CEIG document (signatures required).

Customer _____

Xerox/Partner Sales Representative _____

Xerox/Partner Analyst Representative _____

Xerox/Partner Service Representative _____