

# P3 Tower User Guide

Lenovo  
**ThinkStation**



## **Read this first**

Before using this documentation and the product it supports, ensure that you read and understand the following:

- *Safety and Warranty Guide*
- [Generic Safety and Compliance Notices](#)
- *Setup Guide*

**First Edition (May 2023)**

**© Copyright Lenovo 2023.**

LIMITED AND RESTRICTED RIGHTS NOTICE: If data or software is delivered pursuant to a General Services Administration "GSA" contract, use, reproduction, or disclosure is subject to restrictions set forth in Contract No. GS-35F-05925.

---

# Contents

## Discover your Lenovo computer . . . . .iii

### Chapter 1. Meet your computer . . . . . 1

Front . . . . .	1
Rear . . . . .	3
Specifications . . . . .	5
Expand your computer . . . . .	8
USB specifications . . . . .	9
The Vantage app . . . . .	10

### Chapter 2. Get started with your computer . . . . . 11

Connect an external display . . . . .	11
Transfer data . . . . .	11
Lock the computer . . . . .	12
Access networks . . . . .	14
Diagnostics . . . . .	15
Troubleshooting and FAQs . . . . .	15
Recovery . . . . .	15

### Chapter 3. Advanced configurations . . . . . 17

Set the power plan . . . . .	17
Use software security solutions. . . . .	17
Use BIOS security solutions . . . . .	17
UEFI BIOS passwords . . . . .	19
Certificate-based BIOS management . . . . .	20
What is UEFI BIOS. . . . .	20
Enter the BIOS menu. . . . .	21
Navigate in the BIOS interface . . . . .	21
Change the display mode of UEFI BIOS (for selected models) . . . . .	21
Set the system date and time . . . . .	21
Change the priority boot order . . . . .	22
Enable or disable the configuration change detection feature . . . . .	22
Enable or disable the automatic power-on feature . . . . .	23
Enable or disable the smart power-on feature (for selected models) . . . . .	23
Change the ITS performance mode . . . . .	23
Change BIOS settings before installing a new operating system . . . . .	23
Update UEFI BIOS. . . . .	24

### Chapter 4. RAID . . . . . 25

What is RAID . . . . .	25
------------------------	----

RAID Level. . . . .	25
Configure the system BIOS to enable SATA or NVMe RAID functionality . . . . .	25
Configure RAID in UEFI mode . . . . .	26

### Chapter 5. CRU replacement . . . . . 27

CRU list . . . . .	27
System board . . . . .	29
Remove or replace a CRU. . . . .	30
Left side cover . . . . .	30
Side fan with bracket . . . . .	31
Primary storage drive . . . . .	31
Secondary storage drive cage . . . . .	34
Secondary storage drive . . . . .	35
Storage drive in the front-access storage enclosure . . . . .	37
Front-access storage enclosure. . . . .	41
Front fan. . . . .	42
Front bezel . . . . .	43
Front-access storage enclosure dummy bezel . . . . .	44
Card reader . . . . .	45
PCI-Express card bracket . . . . .	46
PCI-Express card . . . . .	47
Flexible I/O port card . . . . .	50
Chassis beam. . . . .	51
Rear fan . . . . .	52
Cover presence switch . . . . .	54
Internal speaker . . . . .	54
Wi-Fi antenna cover . . . . .	55
M.2 solid-state drive and heat sink . . . . .	56
M.2 solid-state drive bracket . . . . .	59
Memory module. . . . .	59
E-lock. . . . .	60
Chassis rubber foot . . . . .	61

### Chapter 6. Help and support . . . . . 63

Self-help resources . . . . .	63
Call Lenovo . . . . .	64
Certification-related information . . . . .	65
Compliance information . . . . .	65
Purchase accessories . . . . .	65
Purchase additional services. . . . .	66

### Appendix A. Notices and trademarks. . . . . 67



---

## Discover your Lenovo computer

**Thank you for choosing a Lenovo® computer! We are dedicated to delivering the best solution to you.**

Before starting your tour, please read the following information:

- Illustrations in this documentation might look different from your product.
- Depending on the model, some optional accessories, features, software programs, and user interface instructions might not be applicable to your computer.
- Documentation content is subject to change without notice. To get the latest documentation, go to <https://pcsupport.lenovo.com>.



---

## Chapter 1. Meet your computer

**Attention:** Do not block air vents on the side cover. To ensure heat dissipation, do not place any objects within 30 mm from the side cover.

---

### Front

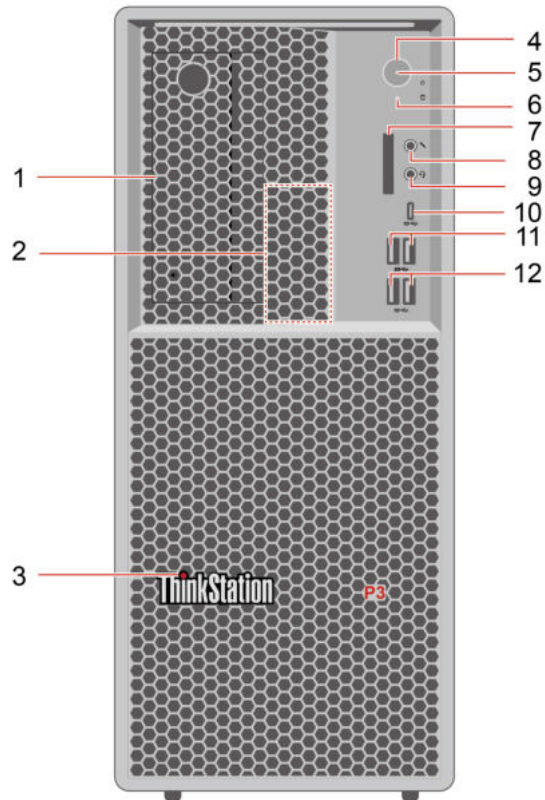

Item	Description	Item	Description
1	Flex bay	2	Internal speaker
3	ThinkStation® LED	4	Power button
5	Power indicator	6	Storage drive activity indicator
7	SD-card slot	8	Microphone connector
9	Headset connector	10	USB-C® (3.2 Gen 2) connector
11	USB-A 3.2 Gen 1 connectors	12	USB-A 3.2 Gen 2 connectors

\* for selected models

### Statement on USB transfer rate

Depending on many factors such as the processing capability of the host and peripheral devices, file attributes, and other factors related to system configuration and operating environments, the actual transfer rate using the various USB connectors on this device will vary and will be slower than the data rate listed below for each corresponding device.

USB device	Data rate (Gbit/s)
3.2 Gen 1	5
3.2 Gen 2	10
3.2 Gen 2 × 2	20
Thunderbolt 3	40
Thunderbolt 4	40

### Power indicator

Show the system status of your computer.

- **On:** The computer is starting up or working.
- **Off:** The computer is off or in hibernation mode.
- **Blinking:** The computer is in sleep mode.

### Headset connector

The headset connector is compatible with:

- Headphones or earphones with a 3.5 mm (0.14 inch), TRS (3-pole) plug
- Headsets with a 3.5 mm (0.14 inch), CTIA-compliant TRRS (4-pole) plug

**Note:** This headset connector does not support standalone external microphones with a TRS (3-pole) plug or headsets with an OMTP-compliant TRRS (4-pole) plug.

### Related topics

- “USB specifications” on page 9.



## Rear

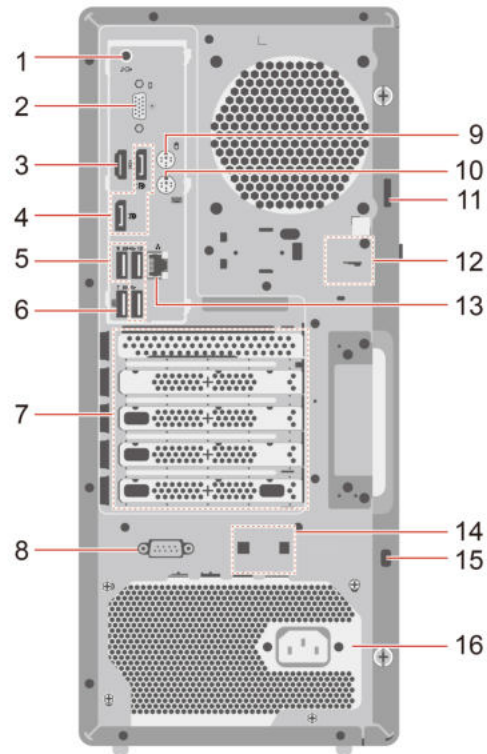

Item	Description	Item	Description
1	Audio line-out connector	2	Optional connector*
3	HDMI™ out connector	4	DisplayPort™ out connectors
5	USB-A 3.2 Gen 1 connectors	6	USB-A 3.2 Gen 1 connector (with smart power-on feature)
7	PCI-Express card area	8	Serial connector*
9	PS/2 mouse connector*	10	PS/2 keyboard connector*
11	Padlock loop	12	E-lock slots
13	Ethernet connector	14	Smart cable clip slots
15	Security-lock slot	16	Power cord connector

\* for selected models

### Serial connector

Connect an external modem, a serial printer, or other devices that use a serial connector.

### Optional connector

Depending on the computer model, the connector might be a DisplayPort out connector, a USB-C (3.2 Gen 1) connector, an HDMI™ out connector or a VGA connector.

**Related topics**

- “USB specifications” on page 9.
- “Connect an external display” on page 11.
- “Lock the computer” on page 12.
- “Enable or disable the smart power-on feature (for selected models)” on page 23.

---

## Specifications

---

Specification	Description
<b>Dimensions</b>	<ul style="list-style-type: none"><li>• Width: 180 mm (7.09 inches)</li><li>• Height: 415 mm (16.34 inches)</li><li>• Depth: 370 mm (14.57 inches)</li></ul>
<b>Weight (without packaging)</b>	Maximum configuration as shipped: 13.6 kg (29.9 lb)
<b>Hardware configuration</b>	Type Device Manager in the Windows search box and then press Enter. Type the administrator password or provide confirmation, if prompted.
<b>Power supply</b>	<ul style="list-style-type: none"><li>• 1100-watt automatic voltage-sensing power supply</li><li>• 750-watt automatic voltage-sensing power supply</li><li>• 500-watt automatic voltage-sensing power supply</li></ul>
<b>Electrical input</b>	<ul style="list-style-type: none"><li>• Input voltage: From 100 V ac to 240 V ac</li><li>• Input frequency: 50/60 Hz</li></ul>
<b>Memory</b>	Up to four DDR5 (double data rate 5) UDIMMs (unbuffered dual inline memory modules).  Maximum memory capacity: 128 GB
<b>Storage device</b>	<ul style="list-style-type: none"><li>• 3.5-inch hard disk drive</li><li>• 2.5-inch hard disk drive*</li><li>• 2.5-inch solid-state drive*</li><li>• M.2 solid-state drive*</li></ul> <p>To view the storage drive capacity of your computer, type Disk Management in the Windows search box and then press Enter.</p> <p><b>Note:</b> The storage drive capacity indicated by the system is less than the nominal capacity.</p>
<b>Video features</b>	<ul style="list-style-type: none"><li>• The integrated graphics card supports the following:<ul style="list-style-type: none"><li>– DisplayPort out connector</li><li>– HDMI out connector</li><li>– VGA-out connector*</li><li>– USB-C (3.2 Gen 1) connector*</li></ul></li><li>• The optional discrete graphics card provides an enhanced video experience and extended capabilities.</li></ul>

---

Specification	Description
<b>Expansion</b>	<ul style="list-style-type: none"> <li>• Flex bay</li> <li>• Memory slots</li> <li>• SD-card slot (supporting SD card reader*)</li> <li>• M.2 solid-state drive Gen 4 slots</li> <li>• 3.5-inch primary storage drive cages</li> <li>• PCI-Express x1 card slots</li> <li>• PCI-Express x16 Gen 4 graphics card slot</li> <li>• PCIe x16 Gen 4 slot (negotiable link width x4)</li> </ul>
<b>Network features</b>	<ul style="list-style-type: none"> <li>• Bluetooth*</li> <li>• Ethernet LAN</li> <li>• Wireless LAN*</li> </ul>

\* for selected models

## Operating environment

### Maximum altitude (without pressurization)

- Operating: From 0 m (0 ft) to 3048 m (10 000 ft)
- Storage: From 0 m (0 ft) to 12192 m (40 000 ft)

### Temperature

- Operating: From 10°C (50°F) to 35°C (95°F)
- Storage: From -40°C (-40°F) to 60°C (140°F)

### Relative humidity

- Operating: 20%-80% (non-condensing)
- Storage: 10%–90% (non-condensing)

### System memory speed

The Intel Xeon® or Intel Core™ microprocessor families compatible with this ThinkStation computer feature an integrated memory controller. The memory controller provides the microprocessor with direct access to the system memory. Therefore, the system memory speed will be determined by the memory module type, frequency, size (capacity), the number of memory modules installed, and the microprocessor model.

### Notes:

- The actual system memory speed of the memory modules varies depending on the microprocessor model. For example, your computer comes with 5600 MT/s memory modules, but the microprocessor only supports up to 4400 MT/s memory modules. Then the system memory speed will be no faster than 4400 MT/s.
- The microprocessor models supported in your computer might vary. For a list of supported microprocessor models, contact the Lenovo Customer Support Center.
- Your computer comes with 5600 MT/s memory modules and will run at lower speed due to platform limitations.

- Ensure that you follow the installation order for memory modules shown in the following illustration.

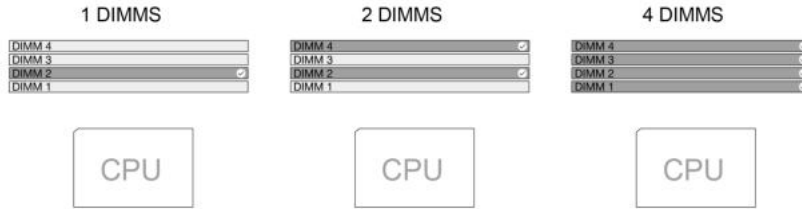

Refer to the following information about the system memory speed:

- **Memory module types:**
  - ECC DDR5 UDIMMs
  - Non-ECC DDR5 UDIMMs
- **Memory module speed:**
  - 1x 8GB / 2x 8GB / 1x 16GB / 2x 16GB / 1x 32GB / 2x 32GB configurations run at DDR5-4400;
  - 4x 8GB / 4x 16GB configurations run at DDR5-4000;
  - 4x 32GB configuration runs at DDR5-3600.

## Expand your computer

You can enhance your computer capacity and performance by adding various devices according to the following rules:

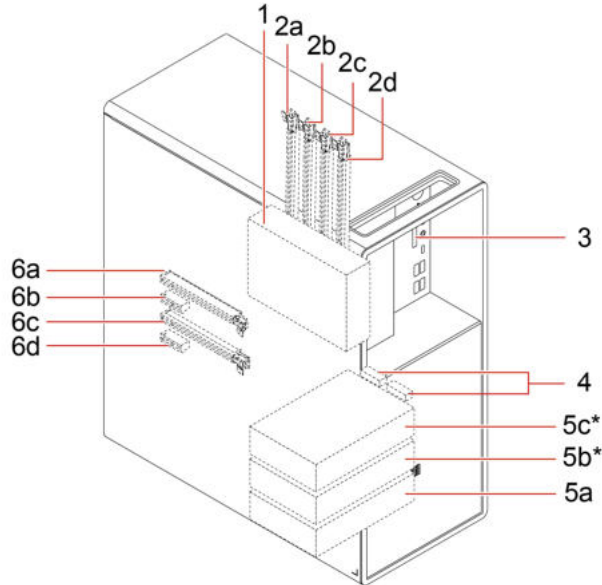

\* for selected models





Location	Rules
1. Flex bay	<p>Your computer has a flex bay for installing one of the following devices:</p> <ul style="list-style-type: none"> <li>• Secondary storage drive cage</li> <li>• Front-access storage enclosure</li> </ul> <p>In the secondary storage drive cage or the front-access storage enclosure, you can install one of the following storage drives with storage drive tray:</p> <ul style="list-style-type: none"> <li>• 3.5-inch storage drive</li> <li>• 2.5-inch storage drive with a storage drive converter</li> </ul> <p><b>Note:</b> The applicable storage drive tray and storage drive converter may vary from locations or devices.</p>
2. Memory slots	<p>Your computer has four memory slots for installing the following memory modules:</p> <ul style="list-style-type: none"> <li>• 16 GB or 32 GB ECC DDR5 UDIMMs</li> <li>• 8GB, 16GB, 32 GB non-ECC DDR5 UDIMMs</li> </ul> <p><b>Notes:</b></p> <ul style="list-style-type: none"> <li>• Supported memory quantity: 1 pcs, 2 pcs, or 4 pcs.</li> <li>• ECC UDIMMs and non-ECC UDIMMs can't be used together.</li> <li>• The four slots support 2DPC (two DIMMs per channel). 2a and 2b is one channel. 2c and 2d is another channel. Symmetric configurations are required within one channel. Ensure that the two DIMMs installed in one channel are purchased from the same manufacturer.</li> </ul>

Location	Rules
3. SD-card slot	You can install a supported media card into the SD-card slot.
4. M.2 solid-state drive slots	Your computer has two M.2 solid-state drive slots for installing M.2 solid-state drives.
5. Primary storage drive cages	<p>Your computer has up to three primary storage drive cages for installing the following storage drives:</p> <ul style="list-style-type: none"> <li>• 3.5-inch storage drive</li> <li>• 2.5-inch storage drive with a storage drive converter</li> </ul> <p><b>Notes:</b></p> <ul style="list-style-type: none"> <li>• The applicable storage drive tray and storage drive converter may vary from locations or devices.</li> <li>• When your computer is installed with M.2 solid-state drive, only 5a and 5b can be available.</li> </ul>
6. PCIe slots	<p>Your computer has the following PCIe slots:</p> <ul style="list-style-type: none"> <li>• PCIe x1 slots</li> <li>• PCIe x16 Gen 4 graphics card slot</li> <li>• PCIe x16 Gen 4 slot (negotiable link width x4)</li> </ul> <p>You can install compatible PCIe cards and PCIe solid-state drives in the PCIe card slots.</p>
6a. PCIe x16 Gen 4 graphics card slot	<ul style="list-style-type: none"> <li>• Only discrete graphics card can be installed to this slot.</li> <li>• If there is only one discrete graphics card, install it to this slot.</li> <li>• If there are two discrete graphics cards, install the one with higher power consumption to this slot.</li> </ul>

**Note:** To add or replace a device, see Chapter 5 CRU replacement.

## USB specifications

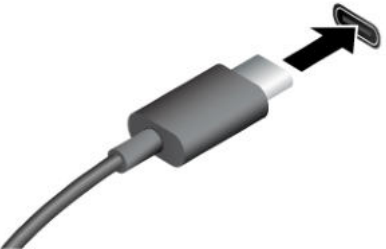
**Note:** Depending on the model, some USB connectors might not be available on your computer.

Connector name	Description
 <ul style="list-style-type: none"> <li>•  USB-A 3.2 Gen 1 connector</li> <li>•  USB-A 3.2 Gen 2 connector</li> </ul>	<p>Connect USB-A compatible devices, such as a USB-A keyboard, USB-A mouse, USB-A storage device, or USB-A printer.</p>
 <ul style="list-style-type: none"> <li>•  USB-C (3.2 Gen 1) connector</li> <li>•  USB-C (3.2 Gen 2) connector</li> </ul>	<ul style="list-style-type: none"> <li>• Charge USB-C compatible devices with the output voltage and current of 5 V and 3 A.</li> <li>• Connect to an external display: <ul style="list-style-type: none"> <li>– USB-C to VGA: 1920 x 1200 pixels, 60 Hz</li> <li>– USB-C to DP: 3840 x 2160 pixels, 60 Hz</li> </ul> </li> <li>• Connect to USB-C accessories to help expand your computer functionality. To purchase USB-C accessories, go to <a href="https://www.lenovo.com/accessories">https://www.lenovo.com/accessories</a>.</li> </ul>

## The Vantage app

The preinstalled Vantage app is a customized one-stop solution to help you maintain your computer with automated updates and fixes, configure hardware settings, and get personalized support.

To access the Vantage app, type Vantage in the Windows search box.

### Key features

The Vantage app enables you to:

- Know the device status easily and customize device settings.
- Download and install UEFI BIOS, firmware and driver updates to keep your computer up-to-date.
- Monitor your computer health, and secure your computer against outside threats.
- Scan your computer hardware and diagnose hardware problems.
- Look up warranty status (online).
- Access *User Guide* and helpful articles.

### Notes:

- The available features vary depending on the computer model.
- The Vantage app makes periodic updates of the features to keep improving your experience with your computer. The description of features might be different from that on your actual user interface.



---

## Chapter 2. Get started with your computer

---

### Connect an external display

Connect a projector or a monitor to your computer to give presentations or expand your workspace.

### Connect a wireless display

Ensure that both your computer and the wireless display support Miracast®.

Press Windows logo key + K and then select a wireless display to connect.

### Change display settings

1. Right-click a blank area on the desktop and select display settings.
2. Select the display that you want to configure and change display settings of your preference.

---

## Transfer data

Quickly share your files using the built-in Bluetooth technology among devices with the same features. You also can install a disc or media card to transfer data.

### Connect to a Bluetooth-enabled device (for selected models)

You can connect all types of Bluetooth-enabled devices to your computer, such as a keyboard, a mouse, a smartphone, or speakers. Place the device that you are attempting to connect to less than 10 meters (33 feet) from the computer.



1. Type Bluetooth in the Windows search box and then press Enter.
2. Turn on Bluetooth, if it is off.
3. Select a Bluetooth device, and then follow the on-screen instructions.

### Install or remove a disc

1. With the computer on, press the eject button on the optical drive. The tray slides out of the drive.
2. Insert a disc into the tray or remove a disc from the tray, and then push the tray back into the drive.

**Note:** If the tray does not slide out of the drive when you press the eject button, turn off the computer. Then, insert a straightened paper clip into the emergency-eject hole adjacent to the eject button. Use the emergency eject only in an emergency.

### Record a disc

1. Insert a recordable disc into the optical drive that supports recording.
2. Do one of the following:
  - Type AutoPlay in the Windows search box and then press Enter. Turn on **Use AutoPlay for all media and devices**.
  - Open Windows Media Player.
  - Double-click the ISO file.
3. Follow the on-screen instructions.

### Use a media card (for selected models)

If your computer has a SD-card slot, read the following information.

#### Install a media card

1. Locate the SD-card slot.
2. Ensure that the metal contacts on the card are facing the ones in the SD-card slot. Insert the card firmly into the SD-card slot until it is secured in place.

#### Remove a media card

**Attention:** Before removing the card:

1. Click the triangular icon in the Windows notification area to show hidden icons. Right-click the icon prompting you to safely remove hardware and eject media.
2. Select the corresponding item to eject the card from the Windows operating system.
3. Press the card and remove it from your computer. Store the card safely for future use.

---

## Lock the computer

**Note:** Lenovo makes no comments, judgments, or warranties about the function, quality, or performance of the locking device and security feature. You can purchase computer locks from Lenovo.

### Padlock

Locking the computer cover through a padlock prevents unauthorized access to the inside of your computer.

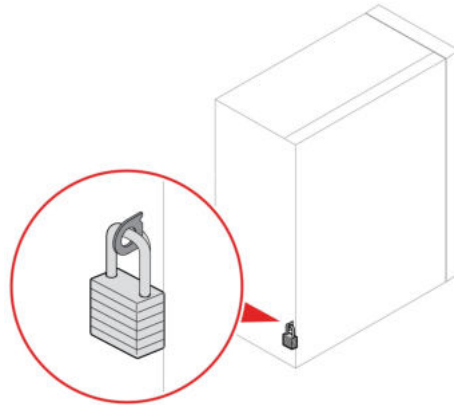

### Security lock

Lock your computer to a desk, table, or other fixtures through a security lock.

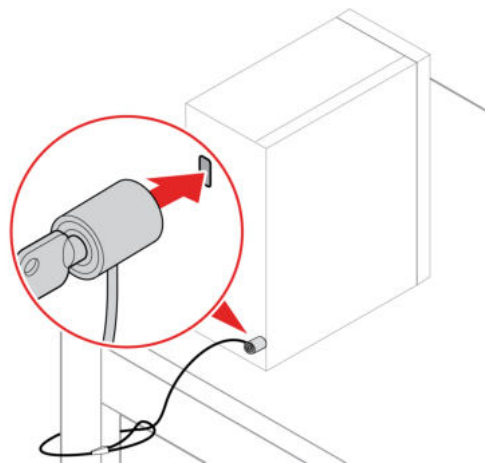

### E-lock

Your computer might have a security lock solution installed to protect the computer from unauthorized tampering of the internal components. Using the E-Lock, you can mechanically lock or unlock the computer cover.

To enable or disable the E-Lock:

1. Restart the computer. When the logo screen is displayed, press F1.
2. Select **Security** → **Electronic Lock** to enable or disable the E-lock.
3. Press F10 to save the changes and exit. Your computer will restart automatically and then changes take effect.

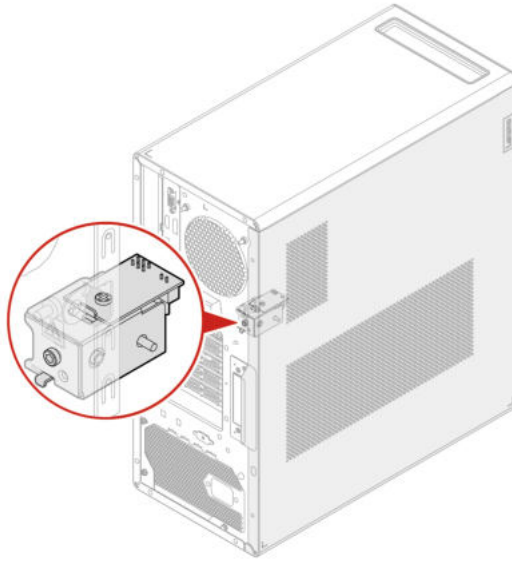

---

## Access networks

This section helps you access networks through connecting to a wired or wireless network.

### Connect to the wired Ethernet

Connect your computer to a local network through the Ethernet connector on your computer with an Ethernet cable.

### Connect to Wi-Fi networks (for selected models)

Click the network icon in the Windows® notification area, and then select a network for connection. Provide required information, if needed.

- For models with Windows 10:

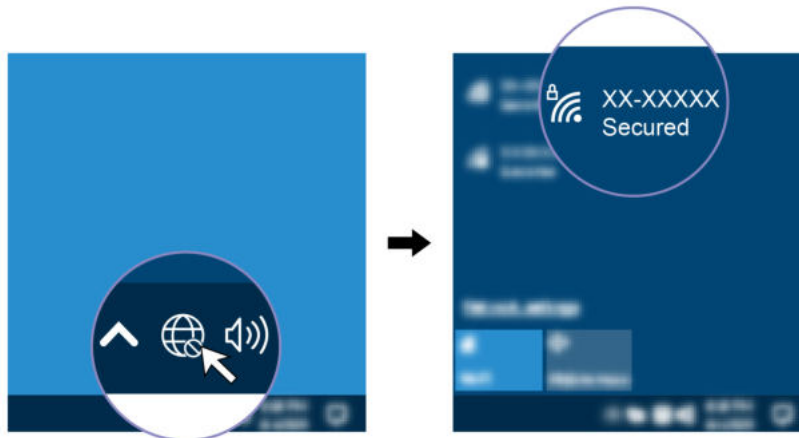

- For models with Windows 11:

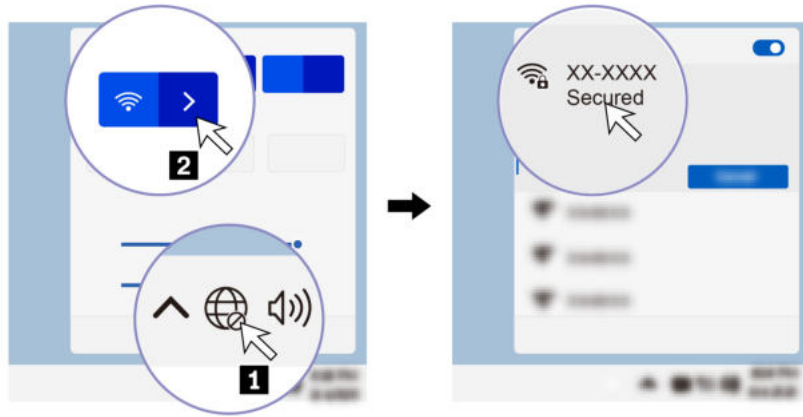

---

## Diagnostics

Use diagnostic solutions to test hardware components and report operating-system-controlled settings that interfere with the correct operation of your computer.

### Lenovo diagnostic tools

For information about Lenovo diagnostic tools, go to:  
<https://pcsupport.lenovo.com/lenovodiagnosicsolutions>

### The Vantage app

The Vantage app is preinstalled on your computer. To diagnose problems with the Vantage app:

1. Type Vantage in the Windows search box and press Enter.
2. Follow the on-screen instructions and run a hardware scan.

If you are unable to isolate and resolve the problem after running the Vantage app, save and print the log files created by the program. You might need the log files when you speak to a Lenovo technical support representative.

---

## Troubleshooting and FAQs

This section lists online access to troubleshoot your computer and to frequently asked questions in Lenovo forums. For more information, go to: <https://www.lenovo.com/tips>, or <https://forums.lenovo.com>.

---

## Recovery

Use the following recovery options to reset or restore your computer when your computer comes with issues.

- Use Lenovo recovery options.
  1. Go to <https://support.lenovo.com/HowToCreateLenovoRecovery>.
  2. Follow the on-screen instructions.
- Use Windows recovery options.
  1. Go to <https://pcsupport.lenovo.com>.
  2. Detect your computer or manually select your computer model.
  3. Navigate to the troubleshooting menu to diagnose the operating system for recovery instructions.



---

## Chapter 3. Advanced configurations

---

### Set the power plan

For ENERGY STAR® compliant computers, the following power plan takes effect when your computers have been idle for a specified duration:

- Turn off the display: After 10 minutes
- Put the computer to sleep: After 25 minutes

To awaken the computer from Sleep mode, press any key on your keyboard.

To reset the power plan:

1. Type **Power Options** in the Windows search box and then press **Enter**.
2. Choose or customize a power plan of your preference.

---

### Use software security solutions

The following software solutions help secure your computer and information.

- **Windows Security**

Windows Security is a software built-in to the operating system. It continually scans for malicious software, viruses, and other security threats. Besides, Windows updates are downloaded automatically to help keep your computer safe. Windows Security also enables you to manage tools including firewall, account protection, application and browser control, and so on.

- **Antivirus programs**

Lenovo preinstalls a full-version antivirus software on selected models of computer. It helps defend the computer against viruses, safeguard your identity, and keep your personal information secured.

- **Absolute Persistence**

Absolute Persistence technology is embedded in firmware. It detects changes that happen on the hardware, software, or the call-in location. It keeps you always knowing what condition the computer is in. To activate the technology, you have to purchase a subscription to Absolute.

**Note:** For more information about how to use these software solutions, refer to their help systems respectively.

---

### Use BIOS security solutions

This section provides BIOS solutions to secure your computer and information.

#### Wipe the storage drive data

It is recommended that you wipe the storage drive data before recycling the storage drive or the computer.

To wipe the storage drive data:

1. Restart the computer. When the logo screen is displayed, press **F1**.
2. Select **Security** → **secure wipe** → **Enabled**.
3. Press **F10** to save the changes and exit.
4. Restart the computer. When the logo screen is displayed, press **F12**.

5. Select **App Menu** → **secure wipe** and press Enter.
6. Select the storage drive you will wipe and click **NEXT**.
7. Select the entire storage drive or partition to wipe as desired.
8. Select the method as desired and click **NEXT**.
9. Click **Yes** to confirm your option when the prompting window is displayed.
10. If you have set a hard disk password for the storage drive, enter the password. Otherwise, set a temporary password following the on-screen instructions. Then, click **NEXT**. The wiping process begins.

**Note:** Duration of the wiping process varies depending on the storage drive capacity.

11. Click **Reboot** when you are prompted to reset the system, and then one of the following will happen:
  - If the system storage drive data is wiped, you will be prompted that no operating system is found.
  - If the non-system storage drive data is wiped, the computer restarts automatically.

### Cover presence switch

The cover presence switch prevents the computer from logging in to the operating system when the computer cover is not properly installed or closed.

To enable the cover presence switch connector on the system board:

1. Restart the computer. When the logo screen is displayed, press F1.
2. Select **Security** → **Cover Tamper Detected** and press Enter.
3. Select **Enabled** and press Enter.
4. Press F10 to save the changes and exit.

If the cover presence switch is enabled and the computer cover is not correctly installed or closed, an error message will be displayed when you turn on the computer. To bypass the error message and log in to the operating system:

1. Properly install or close the computer cover.
2. Enter the BIOS menu, save and then exit.

### Intel BIOS guard

The Intel® BIOS Guard module cryptographically verifies all BIOS updates. This hardware-based security helps prevent software and malware attacks on the computers BIOS.

### Smart USB Protection

The Smart USB Protection function is a security function that helps prevent data from being copied from the computer to USB storage devices connected to the computer. You can set the Smart USB Protection function to one of the following modes:

- **Disabled** (default setting): You can use the USB storage devices without limitation.
- **Read Only**: You cannot copy data from the computer to the USB storage devices. However, you can access data on the USB storage devices.
- **No Access**: You cannot access the USB storage devices from the computer.

To configure the Smart USB Protection function:

1. Restart the computer. When the logo screen is displayed, press F1.
2. Select **Security** → **Smart USB Protection** and press Enter.
3. Select the desired setting and press Enter.



4. Press F10 to save the changes and exit.

---

## UEFI BIOS passwords

You can set passwords in UEFI (Unified Extensible Firmware Interface) BIOS (Basic Input/Output System) to strengthen the security of your computer.

### Password types

You can set a power-on password, supervisor password, system management password, or hard disk password in UEFI BIOS to prevent unauthorized access to your computer. However, you are not prompted to enter any UEFI BIOS password when your computer resumes from sleep mode.

- Power-on password

When a power-on password is set, you are prompted to enter a valid password each time the computer is turned on.

- Supervisor password

Setting a supervisor password deters unauthorized users from changing configuration settings. If you are responsible for maintaining the configuration settings of several computers, you might want to set a supervisor password.

When a supervisor password is set, you are prompted to enter a valid password each time you try to enter the BIOS menu.

If both the power-on password and supervisor password are set, you can enter either password. However, you must use your supervisor password to change any configuration settings.

- Hard disk password

Setting a hard disk password prevents unauthorized access to the data on the storage drive. When a hard disk password is set, you are prompted to enter a valid password each time you try to access the storage drive.

**Note:** After you set a hard disk password, your data on the storage drive is protected even if the storage drive is removed from one computer and installed in another.

- System management password (for selected models)

You can enable the system management password to have the same authority as the supervisor password to control security related features. To customize the authority of the system management password through the UEFI BIOS menu:

1. Restart the computer. When the logo screen is displayed, press F1.
2. Select **Security** → **System Management Password Access Control**.
3. Follow the on-screen instructions.

If you have set both the supervisor password and the system management password, the supervisor password overrides the system management password.

### Set, change, and remove a password

Before you start, print these instructions.

1. Restart the computer. When the logo screen is displayed, press F1.
2. Select **Security**.
3. Depending on the password type, select **Set Supervisor Password**, **Set Power-On Password**, **Set System Management Password**, or **Hard Disk Password** and press Enter.
4. Follow the on-screen instructions to set, change, or remove a password.
5. Press F10 to save the changes and exit.

You should record your passwords and store them in a safe place. If you forget the passwords, contact a Lenovo-authorized service provider to have the passwords removed.

**Note:** If the hard disk password is forgotten, Lenovo cannot remove the password or recover data from the storage drive.

---

## Certificate-based BIOS management

Certificate-based BIOS authentication (also called the password-less management mode) provides more secure UEFI BIOS management with password-free solution. It is used to replace the supervisor password / system management password for authentication if you have set one.

**Note:** Supervisor password / system management password are disabled automatically when certificate mode is enabled. But the power-on password / hard disk password still can be used normally in certificate mode if you have set one.

For certificate enrollment, see *Certificate Enrollment Guide* at: [https://support.lenovo.com/docs/certificate\\_enrollment\\_guide](https://support.lenovo.com/docs/certificate_enrollment_guide)

### Enter the BIOS menu with certificate

Once you have enrolled the certificate, you can enter the BIOS menu with the certificate.

1. Restart the computer. When the logo screen is displayed, press F1 to enter the BIOS menu.
2. The QR code is displayed. Scan the QR code to save the request data and send the request data to IT admin by e-mail or phone.

**Note:** If you choose to authenticate without the QR code, save the request data in a USB key and send the request data to IT admin by e-mail or phone.

3. Enter the unlock code provided by IT admin and click **OK**.

### Notes:

- The unlock encode is a one-time password and is valid only during logon prompt (in one power-on cycle) for up to two hours.
- If you click **Skip**, you can enter the BIOS setup menu without BIOS management authority. But certificate reset is allowed.

### Reset certificate

The enrolled certificate cannot be disabled. You can reset or remove it:

1. Restart the computer. When the logo screen is displayed, press F1.
2. Enter the BIOS menu with the certificate or skip the certification authentication process.
3. Select **Security** → **Certificate-based BIOS Authentication** → **Reset Certificate**.
4. Follow the on-screen instructions to enter the reset code provided by IT admin.

---

## What is UEFI BIOS

**Note:** The operating system settings might override any similar settings in UEFI BIOS.

UEFI BIOS is the first program that the computer runs when the computer is turned on. UEFI BIOS initializes the hardware components and loads the operating system and other programs. Your computer comes with a setup program with which you can change UEFI BIOS settings.

---

## Enter the BIOS menu

Restart the computer. When the logo screen is displayed, press F1 to enter the BIOS menu.

**Note:** If you have set BIOS passwords, enter the correct passwords when prompted. You also can select **No** or press Esc to skip the password prompt and enter the BIOS menu. However, you cannot change the system configurations that are protected by passwords.

---

## Navigate in the BIOS interface

**Attention:** The default configurations are already optimized for you in **boldface**. Improper change of the configurations might cause unexpected results.

Depending on your keyboard, you can navigate in the BIOS interface by pressing the following keys:

---

Key	Function
F1	General Help
Esc	Exit the submenu
↑ ↓	Locate an item
← →	Move keyboard focus
+/-	Change value
Enter	Enter the submenu
F9	Setup Defaults
F10	Save and exit

---

---

## Change the display mode of UEFI BIOS (for selected models)

You can use UEFI BIOS in the graphic mode or the text mode according to your needs.

The keys on the keyboard used to perform various tasks are displayed at the bottom of the screen. In addition to the keyboard, you also can use the mouse to make selections.

To change the display mode of UEFI BIOS:

1. Restart the computer. When the logo screen is displayed, press F1.
2. Select **Main → Setup Mode Select** and press Enter.
3. Set the display mode as desired.

---

## Set the system date and time

1. Restart the computer. When the logo screen is displayed, press F1.
2. Select **Main → System Time & Date** and press Enter.
3. Set the system date and time as desired.
4. Press F10 to save the changes and exit.

---

## Change the priority boot order

If the computer does not boot from a device as expected, you can change the boot priority order permanently or select a temporary boot device.

### Change the priority boot order permanently

1. Depending on the type of the storage device, do one of the following:
  - If the storage device is internal, go to step 2.
  - If the storage device is a disc, ensure that the computer is on or turn on the computer. Then, insert the disc into the optical drive.
  - If the storage device is an external device other than a disc, connect the storage device to the computer.
2. Restart the computer. When the logo screen is displayed, press F1.
3. Select **Startup → Priority Boot Order**, and then follow the on-screen instructions to change the boot priority order.
4. You can also select the first priority device group by selecting **Startup → First Boot Device**, and then follow the on-screen instructions to select the first boot device within this group. Your computer will boot from the first boot device before trying the boot priority order you set in the previous step.
5. Press F10 to save the changes and exit.

### Select a temporary boot device

**Note:** Not all discs and storage drives are bootable.

1. Depending on the type of the storage device, do one of the following:
  - If the storage device is internal, go to step 2.
  - If the storage device is a disc, ensure that the computer is on or turn on the computer. Then, insert the disc into the optical drive.
  - If the storage device is an external device other than a disc, connect the storage device to the computer.
2. Restart the computer. When the logo screen is displayed, press F12.
3. Select the storage device as desired and press Enter.

If you want to change the boot priority order permanently, select **Enter Setup** on Startup Device Menu and press Enter to enter the BIOS menu.

---

## Enable or disable the configuration change detection feature

If you enable configuration change detection, when the POST detects configuration changes of some hardware devices (such as storage drives or memory modules), an error message will be displayed when you turn on the computer.

To enable or disable the configuration change detection feature:

1. Restart the computer. When the logo screen is displayed, press F1.
2. Select **Security → Configuration Change Detection** and press Enter.
3. Enable or disable the feature as desired.
4. Press F10 to save the changes and exit.

To bypass the error message and log in to the operating system, press F2. To clear the error message, enter the BIOS menu, save and then exit.

---

## Enable or disable the automatic power-on feature

The Automatic Power On item in UEFI BIOS provides various options for you to make your computer start up automatically.

To enable or disable the automatic power-on feature:

1. Restart the computer. When the logo screen is displayed, press F1.
2. Select **Power → Automatic Power On** and press Enter.
3. Select the feature as desired and press Enter.
4. Enable or disable the feature as desired.
5. Press F10 to save the changes and exit.

---

## Enable or disable the smart power-on feature (for selected models)

Ensure that the keyboard is connected to a USB connector supporting the smart power-on feature. With the smart power-on feature enabled, you can start up or wake up the computer from the hibernation mode by pressing Alt+P.

To enable or disable the smart power-on feature:

1. Restart the computer. When the logo screen is displayed, press F1.
2. Select **Power → Smart Power On** and press Enter.
3. Enable or disable the feature as desired.
4. Press F10 to save the changes and exit.

---

## Change the ITS performance mode

You can adjust the acoustic and thermal performance of your computer by changing the ITS performance mode. Three options are available:

- **Balance mode:** The computer works at the balance mode with balanced noise and better performance.
- **Performance mode** (default setting): The computer works at the best performance with normal acoustic level.

**Note:** The term “best” only refers to the best effect among different settings of the product itself.

- **Full Speed:** All fans in the computer will run at full speed.

To change the ITS performance mode:

1. Restart the computer. When the logo screen is displayed, press F1.
2. Select **Power → Intelligent Cooling** and press Enter.
3. Select **Performance Mode** and press Enter.
4. Set the performance mode as desired.
5. Press F10 to save the changes and exit.

---

## Change BIOS settings before installing a new operating system

BIOS settings vary by operating system. Change the BIOS settings before installing a new operating system.

Microsoft constantly makes updates to the Windows operating system. Before installing a particular Windows version, check the compatibility list for the Windows version. For details, go to: <https://support.lenovo.com/us/en/solutions/windows-support>

To change the BIOS settings:

1. Restart the computer. When the logo screen is displayed, press F1.
2. From the main interface, select **Security** → **Secure Boot** and press Enter.
3. Depending on the operating system to be installed, do one of the following:
  - To install a Windows operating system that supports secure boot, select **Enabled** for **Secure Boot**.
  - To install an operating system that does not support secure boot, such as some Linux operating systems, select **Disabled** for **Secure Boot**.
4. Press F10 to save the changes and exit.

---

## Update UEFI BIOS

When you install a new program, device driver, or hardware component, you might need to update UEFI BIOS. You can update the BIOS from your operating system or a flash update disc (supported only on selected models).

Download and install the latest UEFI BIOS update package by one of the following methods:

- From the Vantage app:

Open the Vantage app to check the available update packages. If the latest UEFI BIOS update package is available, follow the on-screen instructions to download and install the package.
- From the Lenovo Support Web site:
  1. Go to <https://pcsupport.lenovo.com>.
  2. Download the flash BIOS update driver for the operating system version or the ISO image version (used to create a flash update disc). Then, download the installation instructions for the flash BIOS update driver you have downloaded.
  3. Print the installation instructions and follow the instructions to update the BIOS.

---

## Chapter 4. RAID

---

### What is RAID

Redundant Array of Independent Disks (RAID) is a technology that provides increased storage functions and reliability through redundancy. It also can improve data storage reliability and fault tolerance compared with single-drive storage systems. Data loss resulting from a drive failure can be prevented by reconstructing missing data from the remaining drives.

When a group of independent physical storage drives is set up to use RAID technology, they are in a RAID array. This array distributes data across multiple storage drives, but the array appears to the host computer as one single storage unit. Creating and using RAID arrays provides high performance, such as the expedited I/O performance, because several drives can be accessed simultaneously.

---

### RAID Level

Your computer must have the minimum number of SATA or NVMe storage drives installed for the supported level of RAID below:

- RAID 0: striped disk array
  - Consists of at least two SATA or NVMe storage drives
  - Supported strip size: 4 KB, 8 KB, 16 KB, 32 KB, 64 KB, or 128 KB
  - Better performance without fault tolerance
- RAID 1: mirrored disk array
  - Consists of two SATA or NVMe storage drives
  - Improved reading performance and 100% redundancy
- RAID 5: block-level striped disk array with distributed parity
  - Consists of at least three SATA or NVMe storage drives
  - Supported strip size: 16 KB, 32 KB, 64 KB, or 128 KB
  - Better performance and fault tolerance
- RAID 10: striped and mirrored disk array
  - Consists of at least four SATA or NVMe storage drives
  - Supported strip size: 4 KB, 8 KB, 16 KB, 32 KB, or 64 KB
  - Better performance without fault tolerance
  - Improved reading performance and 100% redundancy

---

### Configure the system BIOS to enable SATA or NVMe RAID functionality

To enable SATA or NVMe RAID functionality:

1. Restart the computer. When the logo screen is displayed, press F1.
2. Select **Devices** → **Storage Setup** and press Enter.
3. Select **Configure Storage as** and press Enter.
4. Select **RAID** and press Enter.
5. Press F10 to save the changes and exit.

---

## Configure RAID in UEFI mode

This section provides instructions on how to configure RAID in UEFI mode.

### Create RAID volumes in UEFI mode

**Attention:** All the existing data stored on the selected drives will be erased while the RAID volume is being created.

To create RAID volumes:

1. Restart the computer. When the logo screen is displayed, press F1.
2. Select **Devices → Storage Setup** and press Enter.
3. Select **Intel (R) Rapid Storage Technology** and press Enter.
4. Select **Create RAID Volume** and press Enter.
5. Select **Name** and press Enter. When prompted, type a proper RAID Volume name in the field.
6. Select **RAID Level** and press Enter. When prompted, select a RAID level in the field.
7. Use the arrow keys and the space key to mark individual physical storage drives to be added in the RAID volume.
8. Select **Strip Size** and press Enter. When prompted, select a strip size in the field.
9. Select **Capacity** and type a volume size in the field.
10. Select **Create Volume** and press Enter to initiate volume creation.

### Delete RAID volumes in UEFI mode

**Attention:** All the existing data stored on the selected drives will be erased after you delete RAID volumes.

To delete RAID volumes:

1. Restart the computer. When the logo screen is displayed, press F1.
2. Select **Devices → Storage Setup** and press Enter.
3. Select **Intel (R) Rapid Storage Technology** and press Enter.
4. Select the RAID volume to be deleted and press Enter.
5. Select **Delete** and press Enter.
6. Select **Yes** to confirm the deletion of the selected RAID volume. Deleting a RAID volume will reset the storage drives to non-RAID.

### Reset storage drives to non-RAID in UEFI mode

To reset your storage drives to non-RAID:

1. Restart the computer. When the logo screen is displayed, press F1.
2. Select **Devices → Storage Setup** and press Enter.
3. Select **Intel (R) Rapid Storage Technology** and press Enter.
4. Select the RAID volumes and press Enter to view the detailed information. Select the storage drives you want to reset to non-RAID and then press Enter.
5. Select **Reset to Non-RAID** and press Enter.
6. Select **Yes** to reset the storage drives to non-RAID.



---

## Chapter 5. CRU replacement

Customer Replaceable Units (CRUs) are parts that can be replaced by the customer. Lenovo computers contain the following types of CRUs:

- **Self-service CRUs:** Refer to parts that can be replaced easily by customer themselves or by trained service technicians at an additional cost.
- **Optional-service CRUs:** Refer to parts that can be replaced by customers with a greater skill level. Trained service technicians can also provide service to replace the parts under the type of warranty designated for the customer's machine.

If you intend on installing the CRU, Lenovo will ship the CRU to you. CRU information and replacement instructions are shipped with your product and are available from Lenovo at any time upon request. You might be required to return the defective part that is replaced by the CRU. When return is required: (1) return instructions, a prepaid shipping label, and a container will be included with the replacement CRU; and (2) you might be charged for the replacement CRU if Lenovo does not receive the defective CRU within thirty (30) days of your receipt of the replacement CRU. For full details, see the Lenovo Limited Warranty documentation at:

[https://www.lenovo.com/warranty/llw\\_02](https://www.lenovo.com/warranty/llw_02)

---

### CRU list

The following is the CRU list of your computer.

#### Self-service CRUs

- Left side cover
- Side fan with bracket\*
- 3.5-inch storage drive\*
- 2.5-inch storage drive\*
- Storage drive tray\*
- Storage drive converter\*
- Secondary storage drive cage\*
- Front-access storage enclosure\*
- Front-access storage enclosure bezel\*
- Front bezel
- Front-access storage enclosure dummy bezel\*
- PCI-Express card bracket\*
- Chassis beam
- Cover presence switch\*
- Front fan\*
- Rear fan\*
- Wi-fi antenna cover
- M.2 solid-state drive\*
- M.2 solid-state drive bracket, heat sink, and thermal pad\*
- Memory module

- Chassis rubber feet
- Keyboard\*
- Mouse\*
- Power cord

**Optional-service CRUs**

- Card reader\*
- Card reader bracket\*
- PCI-Express card\*
- Flexible I/O port card with bracket\*
- Internal speaker
- M.2 solid-state drive holder\*
- E-lock\*

\* for selected models

# System board

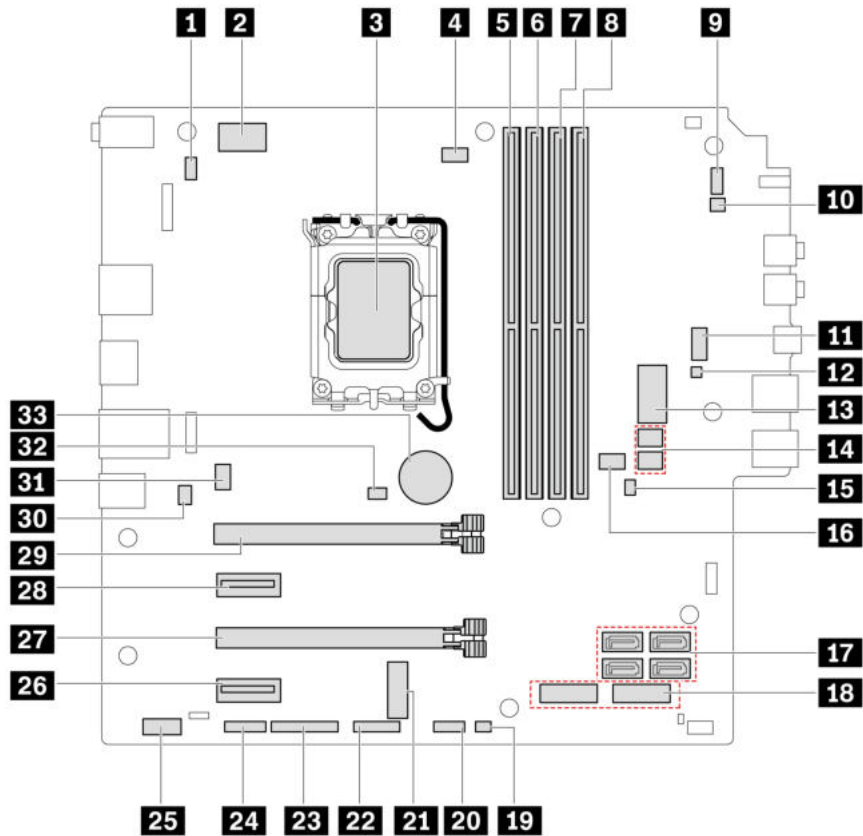

<b>1</b> PS/2 keyboard and mouse connector	<b>2</b> 8-pin power connector
<b>3</b> Microprocessor socket	<b>4</b> Microprocessor fan connector
<b>5</b> Memory slot (DIMM1)	<b>6</b> Memory slot (DIMM2)
<b>7</b> Memory slot (DIMM3)	<b>8</b> Memory slot (DIMM4)
<b>9</b> Power button connector	<b>10</b> Internal speaker connector
<b>11</b> Auxiliary fan connector 1 (front fan)	<b>12</b> ThinkCentre LED connector
<b>13</b> 10-pin power connector	<b>14</b> SATA power connectors
<b>15</b> Clear CMOS (Complementary Metal Oxide Semiconductor)/Recovery jumper	<b>16</b> Auxiliary fan connector 2 (side fan)
<b>17</b> SATA connectors	<b>18</b> M.2 solid-state drive slots
<b>19</b> Thermal sensor connector	<b>20</b> Front USB connector 2
<b>21</b> M.2 Wi-Fi card slot	<b>22</b> Front USB connector 1
<b>23</b> Parallel connector	<b>24</b> Serial (COM) connector
<b>25</b> Thunderbolt™ connector	<b>26</b> PCI-Express x1 card slot
<b>27</b> PCI-Express x16 Gen 4 card slot (link width x4)	<b>28</b> PCI-Express x1 card slot
<b>29</b> PCI-Express x16 Gen 4 graphics card slot	<b>30</b> E-lock connector
<b>31</b>	
<b>32</b>	
<b>33</b>	

<b>31</b> System fan connector (rear fan)	<b>32</b> Cover presence switch connector (intrusion switch connector)
<b>33</b> Coin-cell battery	

## Remove or replace a CRU

This section provides instructions on how to remove or replace a CRU.

### Left side cover

#### Prerequisite

Before you start, read *Generic Safety and Compliance Notices*, and print the following instructions.



Before you open the left side cover, turn off the computer and wait several minutes until the computer is cool.

For access, do the following:

1. Remove any media from the drives and turn off all connected devices and the computer.
2. Disconnect all power cords from electrical outlets and disconnect all cables from the computer.
3. Unlock any locking device that secures the left side cover.
4. Lay down the computer to place the left side cover facing up.

#### Removal steps

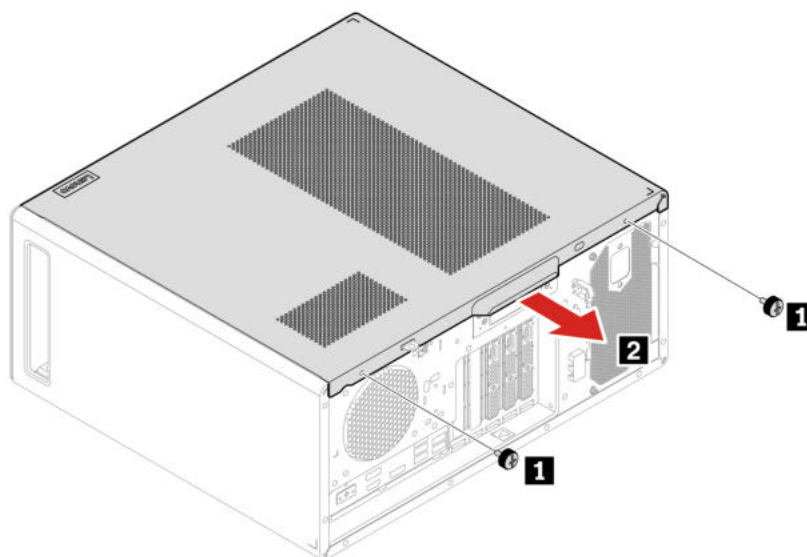

Step	Screw (quantity)	Torque
<b>1</b>	#6-32 × 7.5 mm, Nickel coated (2)	5.0 ± 0.5 in-lb

**Note:** If a locking device is available, use it to lock the computer after installing the left side cover.

## Side fan with bracket

### Prerequisite

Before you start, read *Generic Safety and Compliance Notices*, and print the following instructions.

For access, do the following:

1. Remove the “Left side cover” on page 30.
2. Disconnect the side fan cable from the side fan connector on the system board.

### Removal procedure

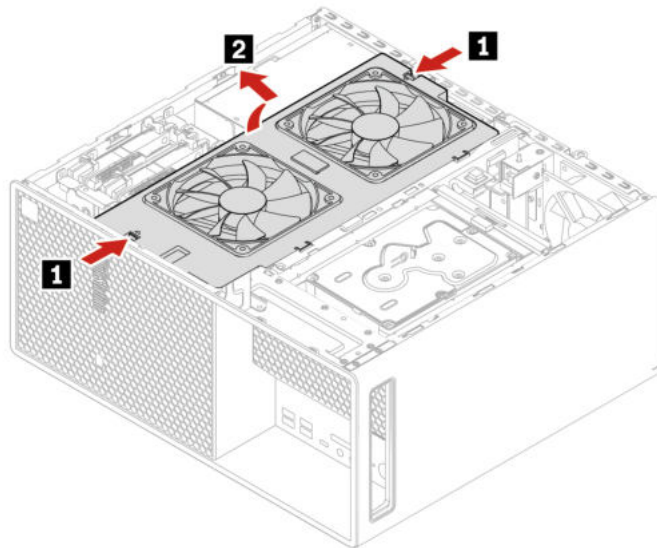

## Primary storage drive

**Note:** Before removing an old storage drive, safely eject the old storage drive from the operating system first. For more information, see the operating system help system.

### Prerequisite

Before you start, read *Generic Safety and Compliance Notices*, and print the following instructions.

**Attention:** The internal storage drive is sensitive. Inappropriate handling might cause damage and permanent loss of data. When handling the internal storage drive, observe the following guidelines:

- Replace the internal storage drive only for upgrade or repair. The internal storage drive is not designed for frequent changes or replacement.
- Before replacing the internal storage drive, make a backup copy of all the data that you want to keep.
- Do not touch the contact edge of the internal storage drive. Otherwise, the internal storage drive might get damaged.

- Do not apply pressure to the internal storage drive.
- Do not make the internal storage drive subject to physical shocks or vibration. Put the internal storage drive on a soft material, such as cloth, to absorb physical shocks.

For access, remove the “Left side cover” on page 30.

### Removal steps of 3.5-inch storage drive

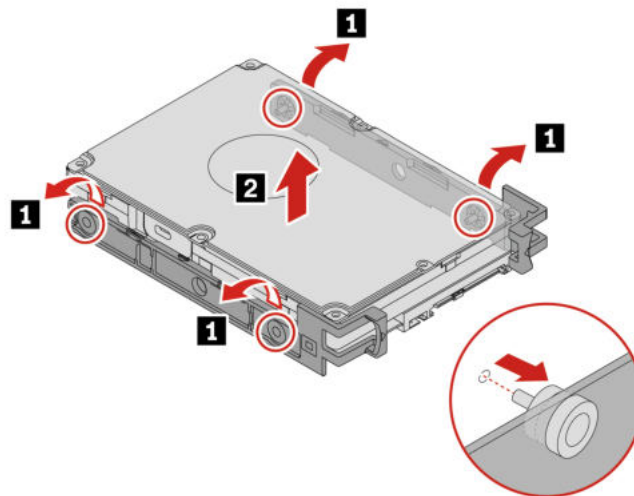
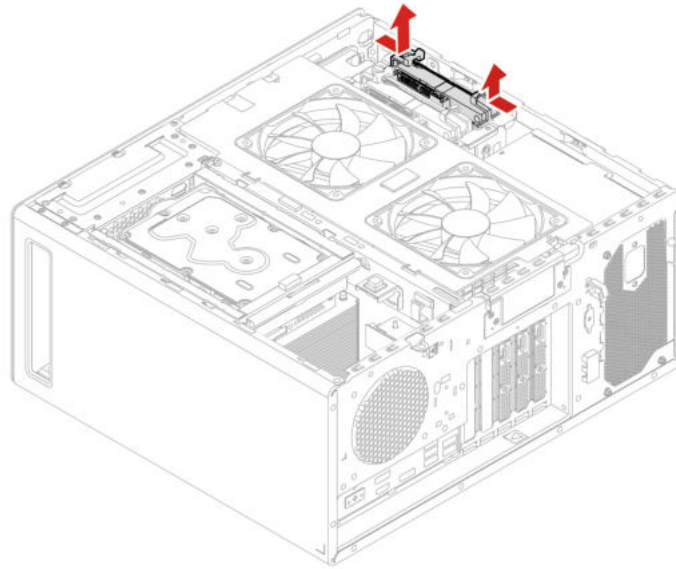

## Removal steps of 2.5-inch storage drive and storage drive converter

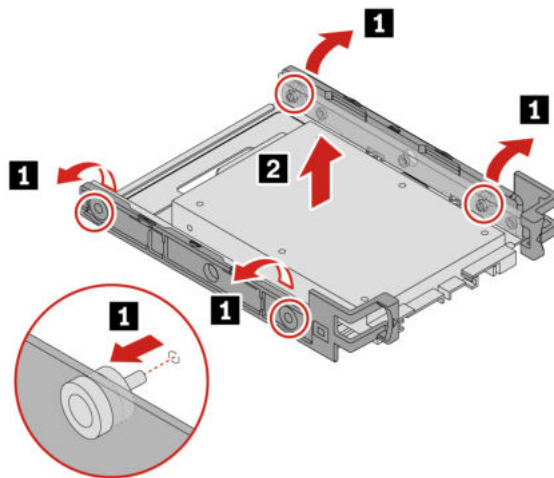
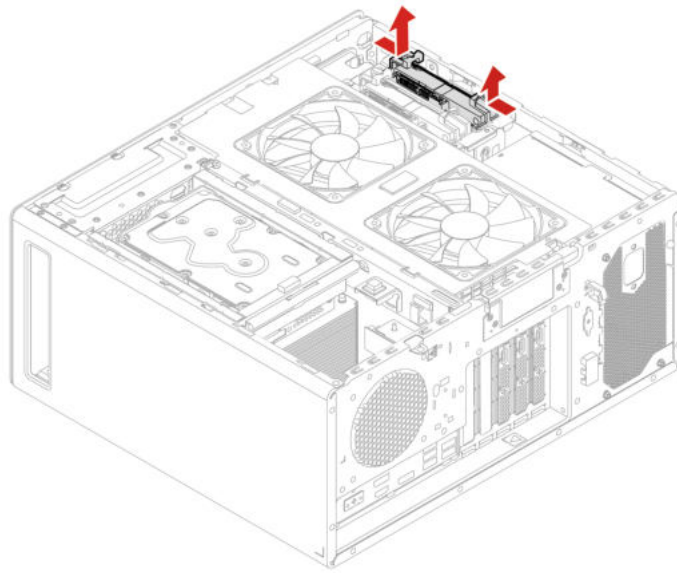

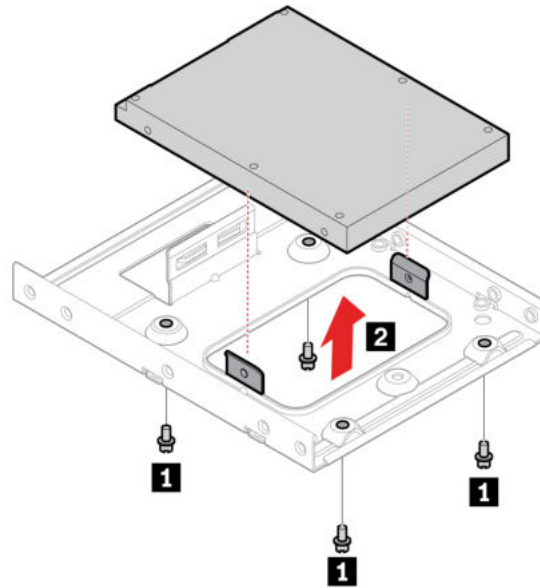

Step	Screw (quantity)	Torque
<b>1</b>	#6-32 × 5 mm, Nickel coated (4)	5.0 ± 0.5 in-lb

## Secondary storage drive cage

**Note:** Before removing an old storage drive, safely eject the old storage drive from the operating system first. For more information, see the operating system help system.

### Prerequisite

Before you start, read *Generic Safety and Compliance Notices*, and print the following instructions.

**Attention:** The internal storage drive is sensitive. Inappropriate handling might cause damage and permanent loss of data. When handling the internal storage drive, observe the following guidelines:

- Replace the internal storage drive only for upgrade or repair. The internal storage drive is not designed for frequent changes or replacement.
- Before replacing the internal storage drive, make a backup copy of all the data that you want to keep.
- Do not touch the contact edge of the internal storage drive. Otherwise, the internal storage drive might get damaged.
- Do not apply pressure to the internal storage drive.
- Do not make the internal storage drive subject to physical shocks or vibration. Put the internal storage drive on a soft material, such as cloth, to absorb physical shocks.

For access, remove the “Left side cover” on page 30.



## Removal step

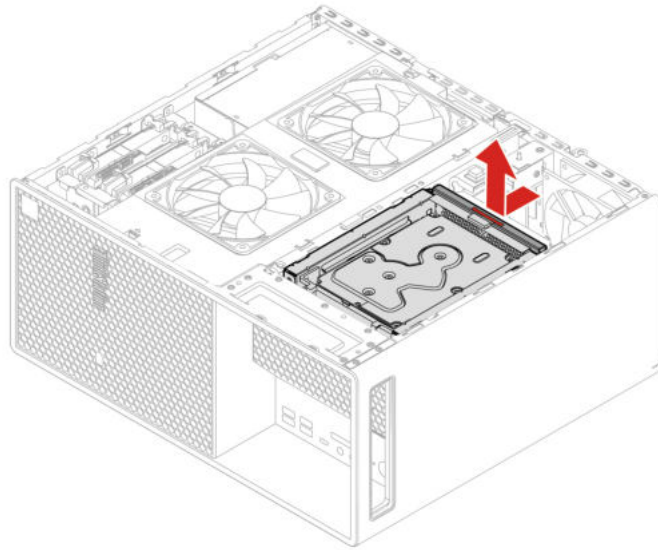

## Secondary storage drive

**Note:** Before removing an old storage drive, safely eject the old storage drive from the operating system first. For more information, see the operating system help system.

### Prerequisite

Before you start, read *Generic Safety and Compliance Notices*, and print the following instructions.

**Attention:** The internal storage drive is sensitive. Inappropriate handling might cause damage and permanent loss of data. When handling the internal storage drive, observe the following guidelines:

- Replace the internal storage drive only for upgrade or repair. The internal storage drive is not designed for frequent changes or replacement.
- Before replacing the internal storage drive, make a backup copy of all the data that you want to keep.
- Do not touch the contact edge of the internal storage drive. Otherwise, the internal storage drive might get damaged.
- Do not apply pressure to the internal storage drive.
- Do not make the internal storage drive subject to physical shocks or vibration. Put the internal storage drive on a soft material, such as cloth, to absorb physical shocks.

For access, remove these parts in order:

- “Left side cover” on page 30
- “Secondary storage drive cage” on page 34

### Removal steps of 3.5-inch storage drive

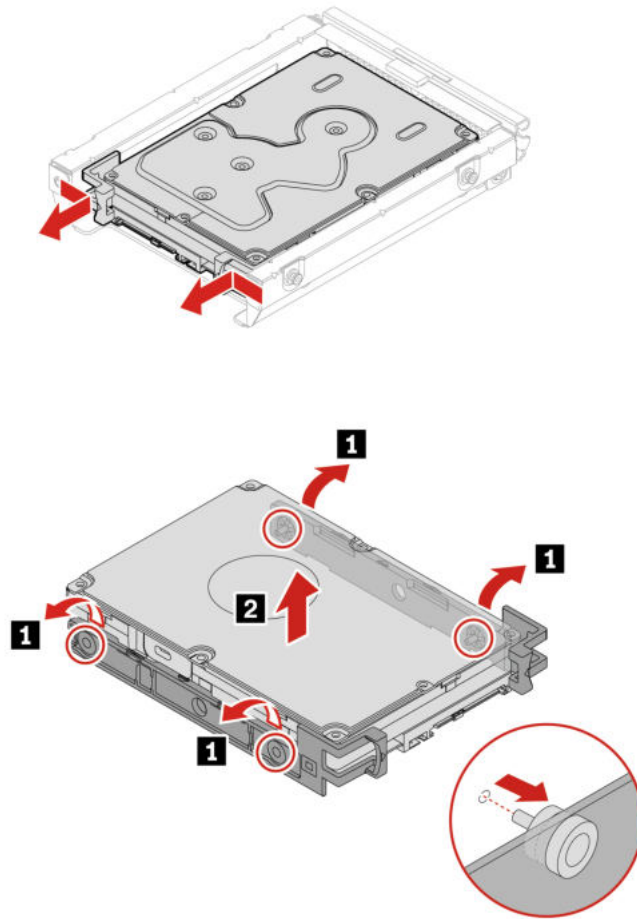

### Removal steps of 2.5-inch storage drive and storage drive converter

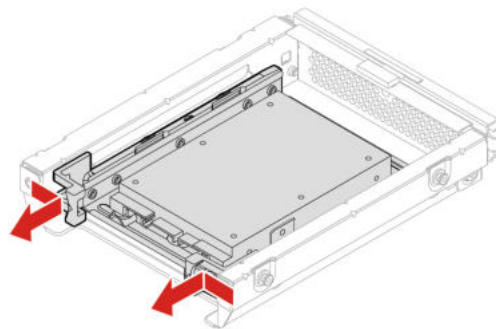

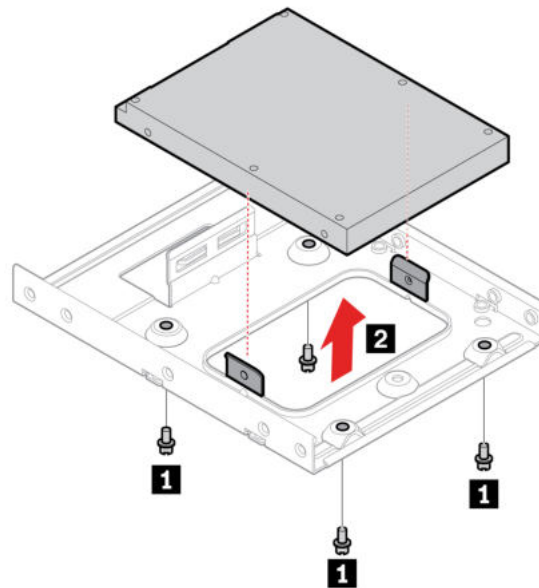
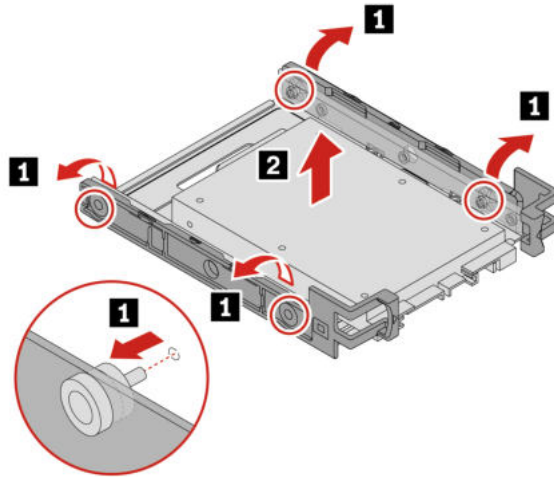

Step	Screw (quantity)	Torque
1	#6-32 × 5 mm, Nickel coated (4)	5.0 ± 0.5 in-lb

## Storage drive in the front-access storage enclosure

### Notes:

- Some computer models might not be shipped with a front-access storage enclosure. In this case, there will be a dummy bezel on the front bezel.
- Before removing an old storage drive, safely eject the old storage drive from the operating system first. For more information, see the operating system help system.

### Prerequisite

Before you start, read *Generic Safety and Compliance Notices*, and print the following instructions.

**Attention:** The internal storage drive is sensitive. Inappropriate handling might cause damage and permanent loss of data. When handling the internal storage drive, observe the following guidelines:

- Replace the internal storage drive only for upgrade or repair. The internal storage drive is not designed for frequent changes or replacement.
- Before replacing the internal storage drive, make a backup copy of all the data that you want to keep.
- Do not touch the contact edge of the internal storage drive. Otherwise, the internal storage drive might get damaged.
- Do not apply pressure to the internal storage drive.
- Do not make the internal storage drive subject to physical shocks or vibration. Put the internal storage drive on a soft material, such as cloth, to absorb physical shocks.

You can install or replace a storage drive in the front-access storage enclosure. The storage drive also can be hot-swappable, which means that you can install or replace the drive without even turning off your computer. Therefore, lock the enclosure cover to prevent the unexpected removal. The keys are attached at the rear of the computer. Store the keys in a secure place.

The storage drive in the front-access storage enclosure is hot-swappable only when the following requirements are met. If any of the requirements are not met, do not install or replace the storage drive when the computer is turned on. Otherwise, data on the storage drive might get damaged.

- The eSATA mode of the SATA 4 connector is enabled in BIOS by doing the following:
  1. Restart the computer. When the logo screen is displayed, press F1.
  2. Select **Devices** → **Storage Setup** → **SATA Drive 4 Hot-Plug Support** and press Enter.
  3. Select **Enabled** and press Enter.
  4. Press F10 to save the changes and exit.
- The SATA cable of the front-access storage enclosure is connected to the SATA 4 connector on the system board.
- The operating system of your computer does not reside on the storage drive installed in the front-access storage enclosure.

## Removal steps of the 3.5-inch storage drive

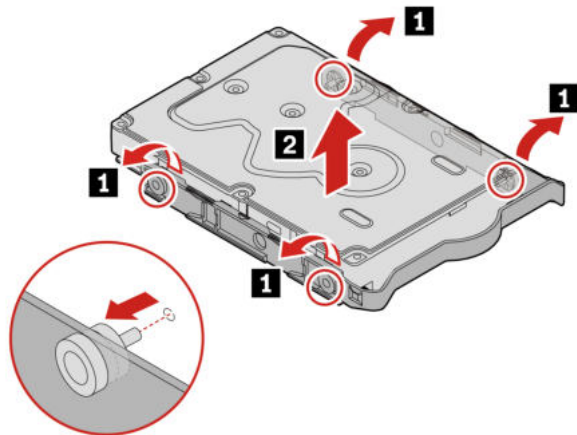
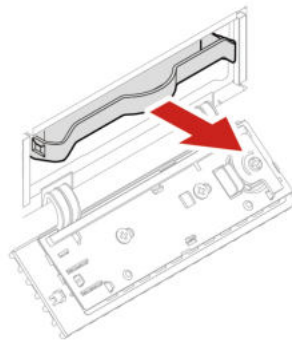
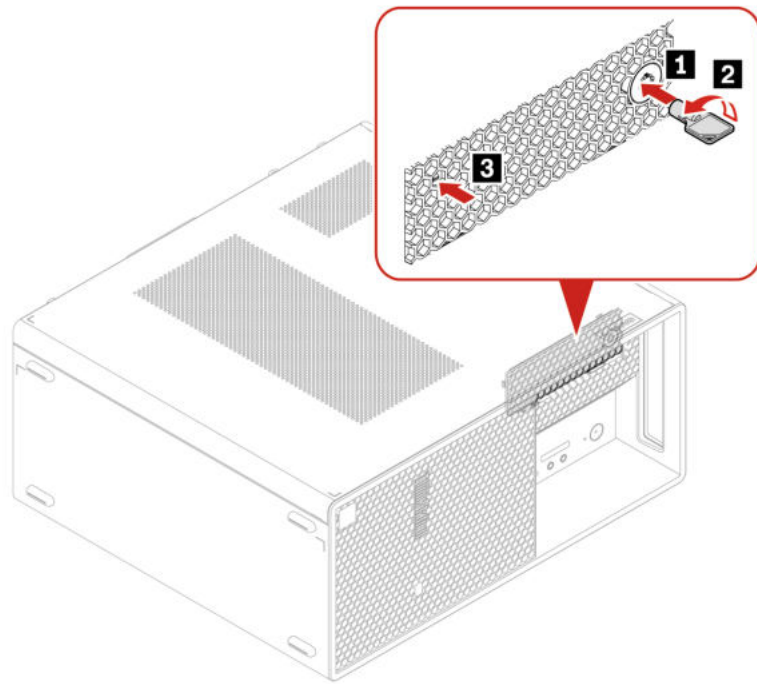

## Removal steps of the 2.5-inch storage drive and storage drive converter

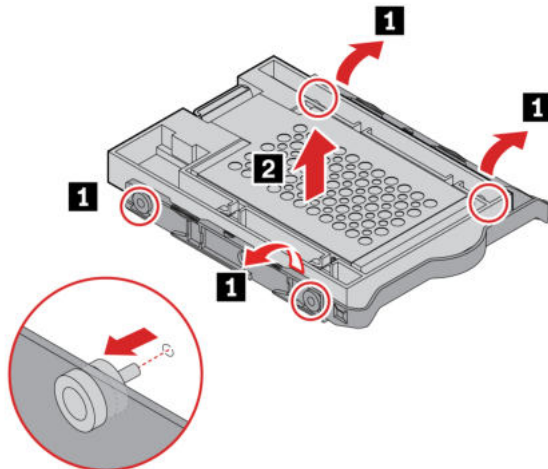
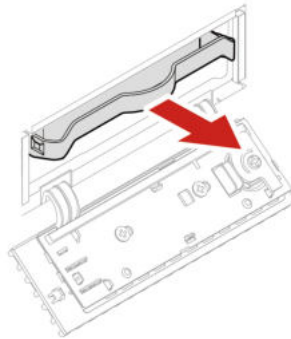
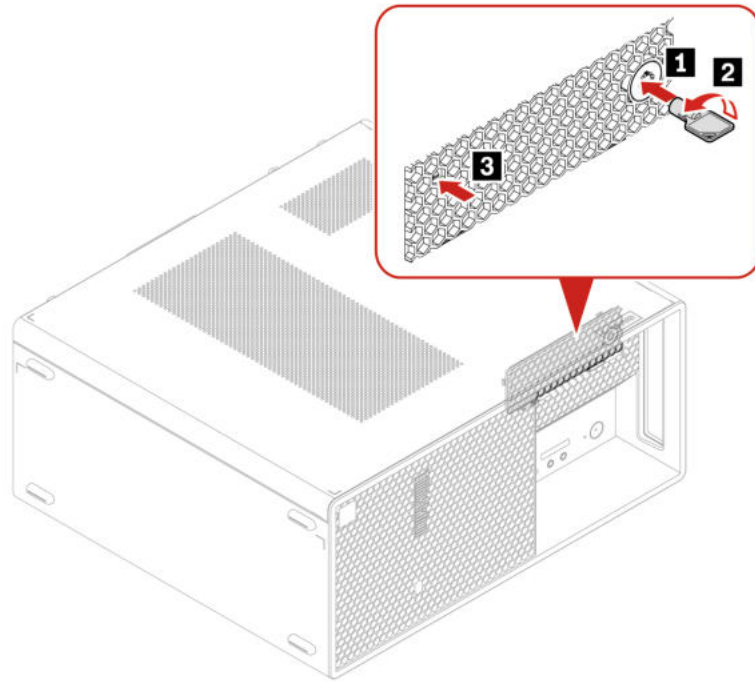

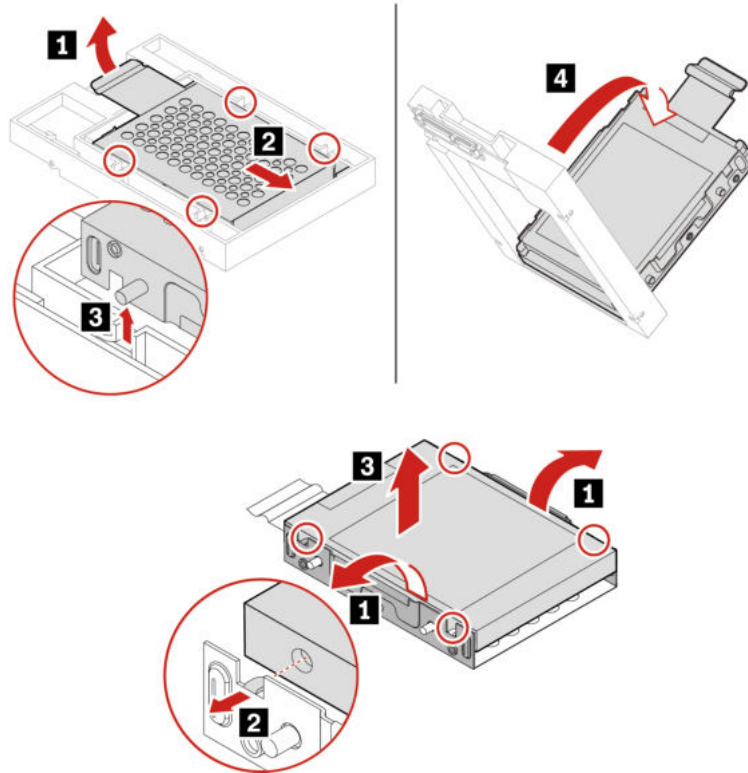

## Front-access storage enclosure

### Notes:

- Some computer models might not be shipped with a front-access storage enclosure. In this case, there will be a dummy bezel on the front bezel.
- Before removing an old storage drive, safely eject the old storage drive from the operating system first. For more information, see the operating system help system.

### Prerequisite

Before you start, read *Generic Safety and Compliance Notices*, and print the following instructions.

**Attention:** The internal storage drive is sensitive. Inappropriate handling might cause damage and permanent loss of data. When handling the internal storage drive, observe the following guidelines:

- Replace the internal storage drive only for upgrade or repair. The internal storage drive is not designed for frequent changes or replacement.
- Before replacing the internal storage drive, make a backup copy of all the data that you want to keep.
- Do not touch the contact edge of the internal storage drive. Otherwise, the internal storage drive might get damaged.
- Do not apply pressure to the internal storage drive.
- Do not make the internal storage drive subject to physical shocks or vibration. Put the internal storage drive on a soft material, such as cloth, to absorb physical shocks.

For access, remove these parts in order:

- “Left side cover” on page 30
- “Storage drive in the front-access storage enclosure” on page 37

## Removal step

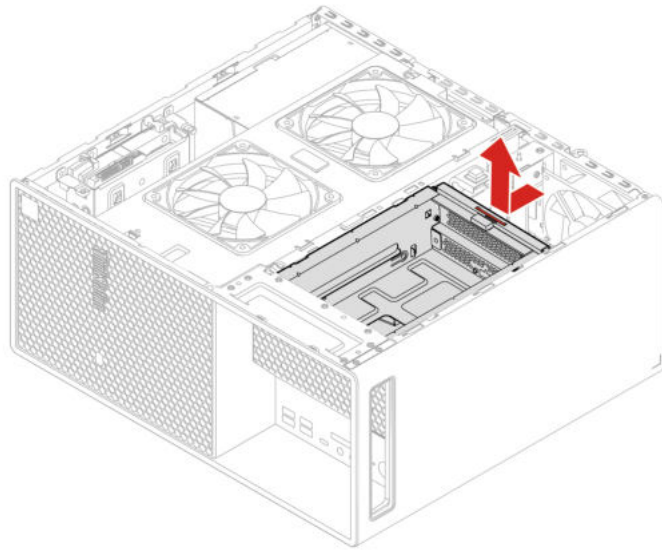

## Front fan

### Prerequisite

Before you start, read *Generic Safety and Compliance Notices*, and print the following instructions.

For access, do the following:

1. Remove these parts in order:
  - “Left side cover” on page 30
  - “Side fan with bracket” on page 31
2. Disconnect the front fan cable from the front fan connector on the system board.

### Removal steps

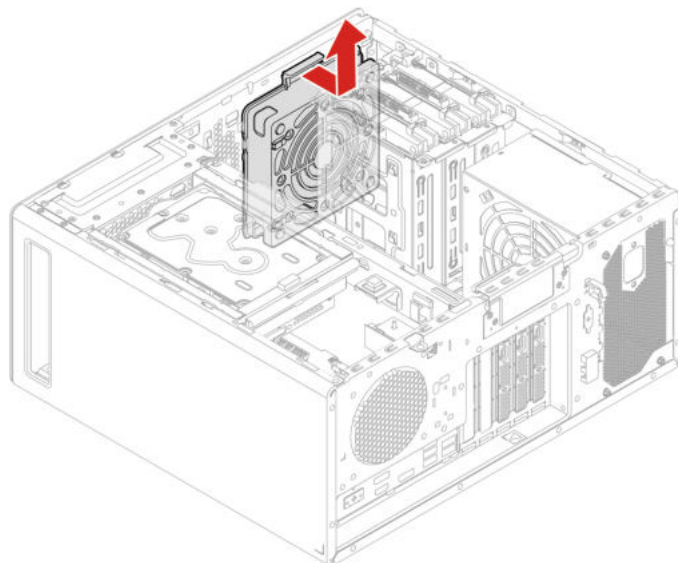



## Front bezel

### Prerequisite

Before you start, read *Generic Safety and Compliance Notices*, and print the following instructions.

For access, remove these parts in order, if any:

- “Left side cover” on page 30
- “Side fan with bracket” on page 31
- “Secondary storage drive cage” on page 34
- “Secondary storage drive” on page 35
- “Storage drive in the front-access storage enclosure” on page 37
- “Front-access storage enclosure” on page 41
- “Front fan” on page 42

### Removal steps

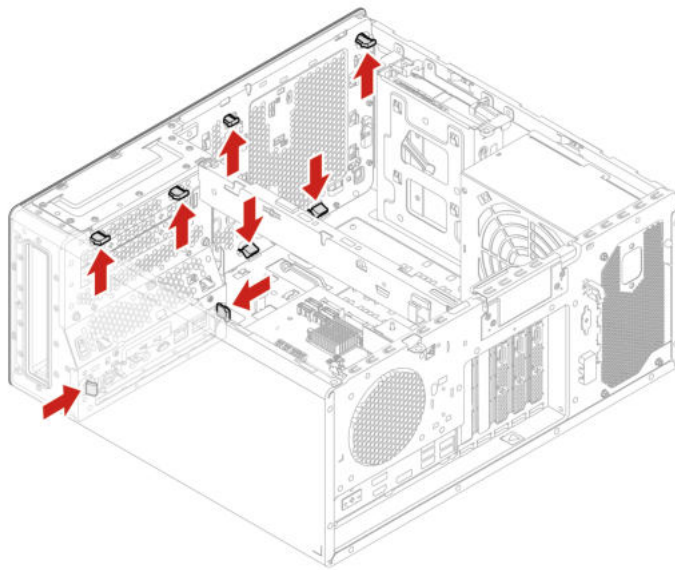

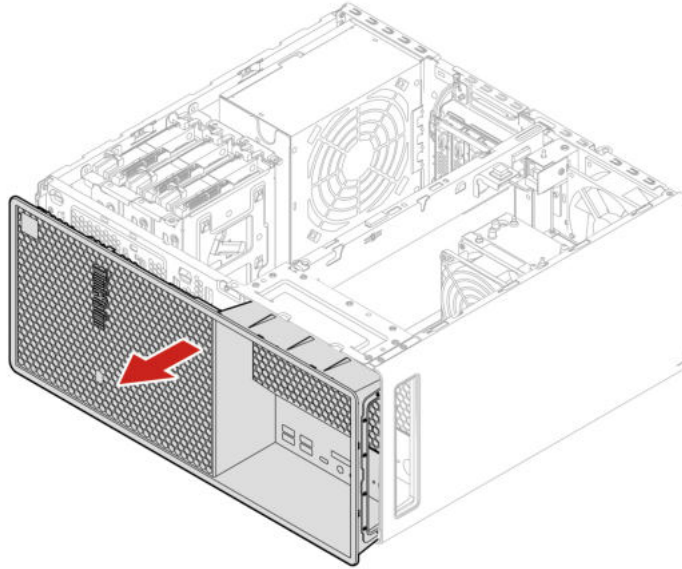

## Front-access storage enclosure dummy bezel

**Note:** Some computer models might not be shipped with a front-access storage enclosure. In this case, remove the dummy bezel for front-access storage enclosure first.

### Prerequisite

Before you start, read *Generic Safety and Compliance Notices*, and print the following instructions.

For access, remove these parts in order, if any:

- “Left side cover” on page 30
- “Side fan with bracket” on page 31
- “Secondary storage drive cage” on page 34
- “Secondary storage drive” on page 35
- “Storage drive in the front-access storage enclosure” on page 37
- “Front-access storage enclosure” on page 41
- “Front fan” on page 42
- “Front bezel” on page 43

## Removal steps

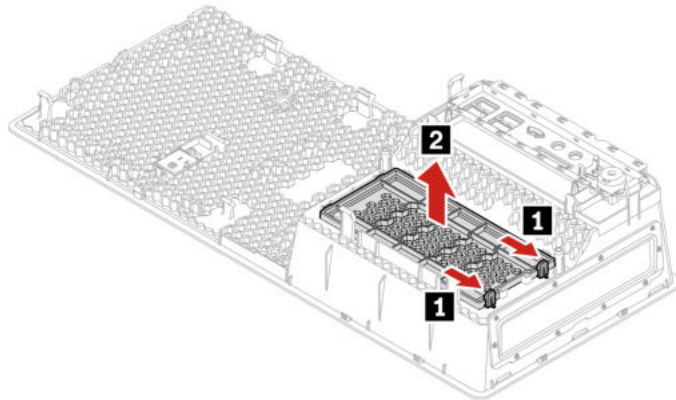

## Card reader

### Prerequisite

Before you start, read *Generic Safety and Compliance Notices*, and print the following instructions.

For access, remove these parts in order, if any:

- “Left side cover” on page 30
- “Secondary storage drive cage” on page 34
- “Secondary storage drive” on page 35
- “Storage drive in the front-access storage enclosure” on page 37
- “Front-access storage enclosure” on page 41

Disconnect the card reader cable from the card reader.

## Removal steps

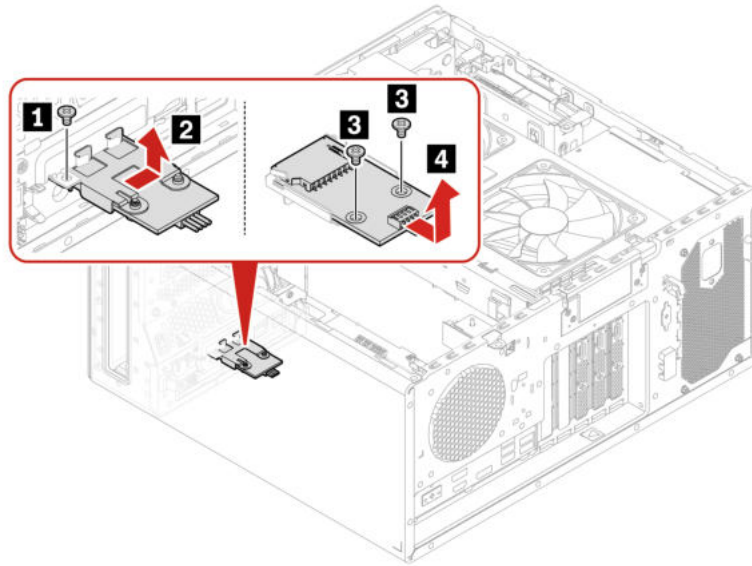

Step	Screw (quantity)	Torque
<b>1</b>	#6-32 × 5 mm, Nickel coated (1)	5.0 ± 0.5 in-lb
<b>3</b>	M3 × 5 mm, Zn coated (2)	5.0 ± 0.5 in-lb

## PCI-Express card bracket

**Note:** Some computer models might not be shipped with PCI-Express card. In this case, the PCI-Express card bracket in the following illustration is removable.

### Prerequisite

Before you start, read *Generic Safety and Compliance Notices*, and print the following instructions.

For access, remove the “Left side cover” on page 30.

## Removal steps

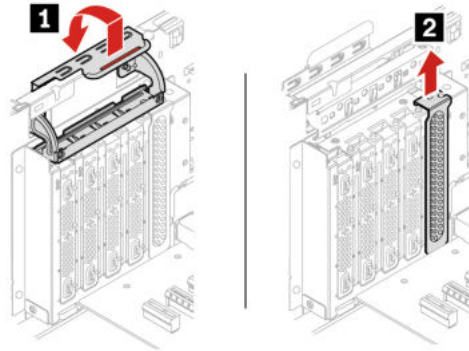

## PCI-Express card

### Prerequisite

Before you start, read *Generic Safety and Compliance Notices*, and print the following instructions.

For access, remove the “Left side cover” on page 30.

### Notes:

- Do not attempt to install any PCI-Express cards other than discrete graphics card to PCI-Express card slot **1**.
- If there is only one discrete graphics card, install it to PCI-Express card slot **1**.
- If there are two discrete graphics cards, install the one with higher power consumption to PCI-Express card slot **1**, and install the other to PCI-Express card slot **3**.

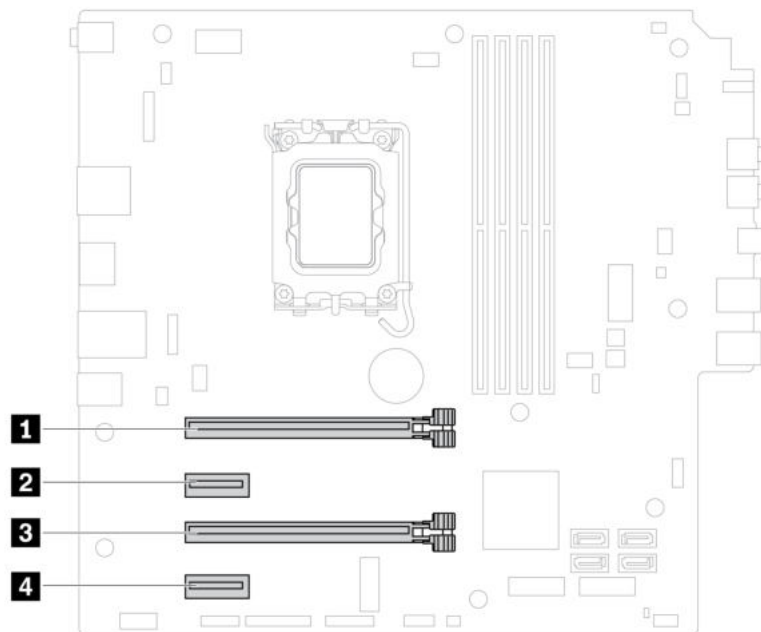

## Removal steps

- Type 1

**Note:** The PCIe card retainer is only available on some graphics cards.

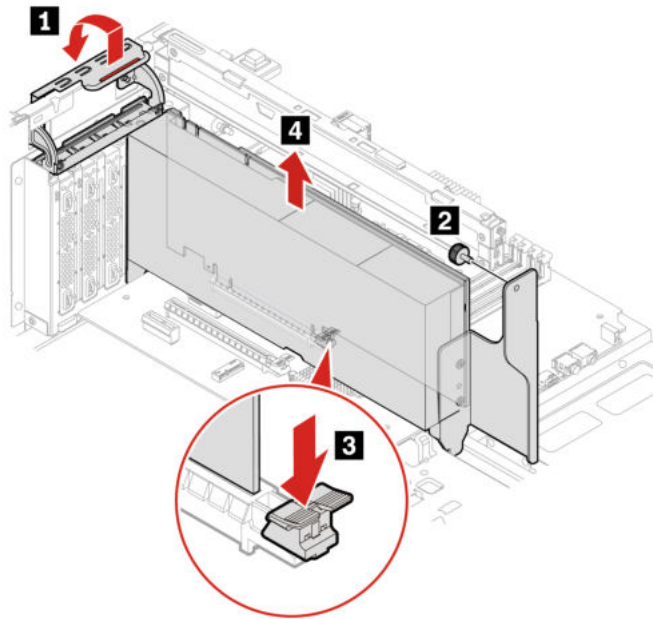
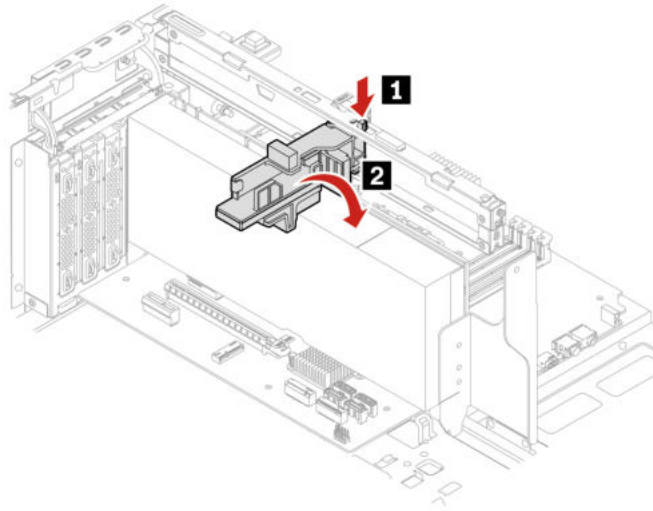

Step	Screw (quantity)	Torque
<b>2</b>	#6-32 × 7.5 mm, Nickel coated (1)	3.0 ± 0.5 in-lb

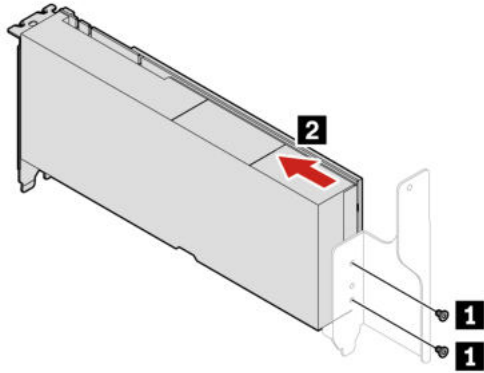

Step	Screw (quantity)	Torque
<b>1</b>	M3 × 5 mm, Zn coated (2)	5.0 ± 0.5 in-lb

- Type 2

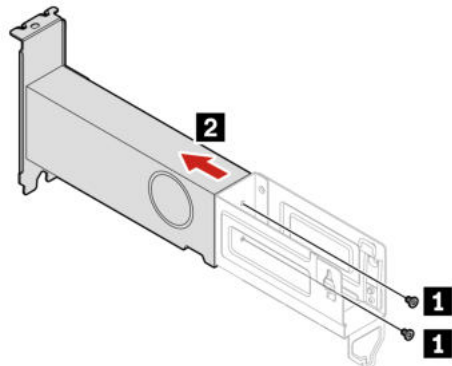
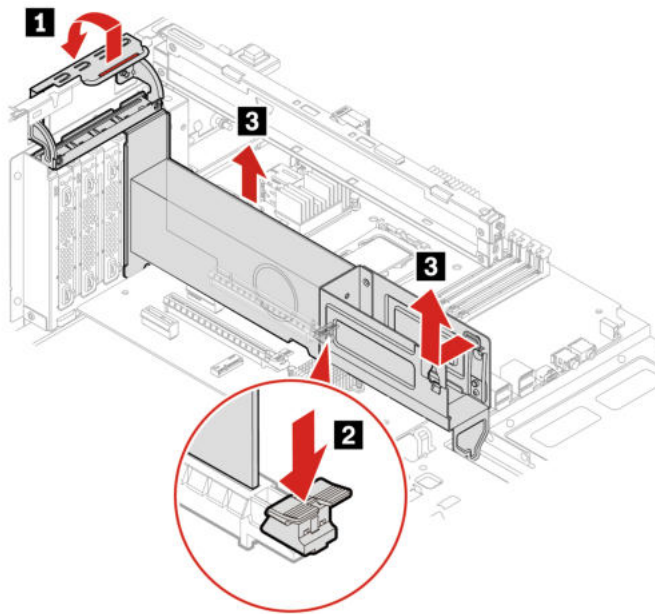

Step	Screw (quantity)	Torque
<b>1</b>	M3 × 5 mm, Zn coated (2)	5.0 ± 0.5 in-lb

## Flexible I/O port card

### Prerequisite

Before you start, read *Generic Safety and Compliance Notices*, and print the following instructions.

For access, remove the “Left side cover” on page 30.

### Removal steps

- Type 1

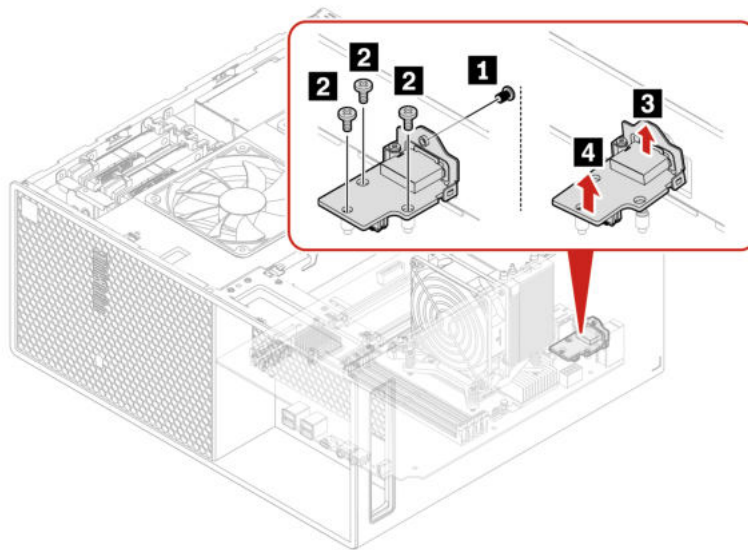

Step	Screw (quantity)	Torque
<b>1</b>	M2-5 × 4 mm, Nickel coated (1)	1.5 ± 0.5 in-lb
<b>2</b>	M3 × 3.2 mm, Nickel coated (3)	5.0 ± 0.5 in-lb

- Type 2



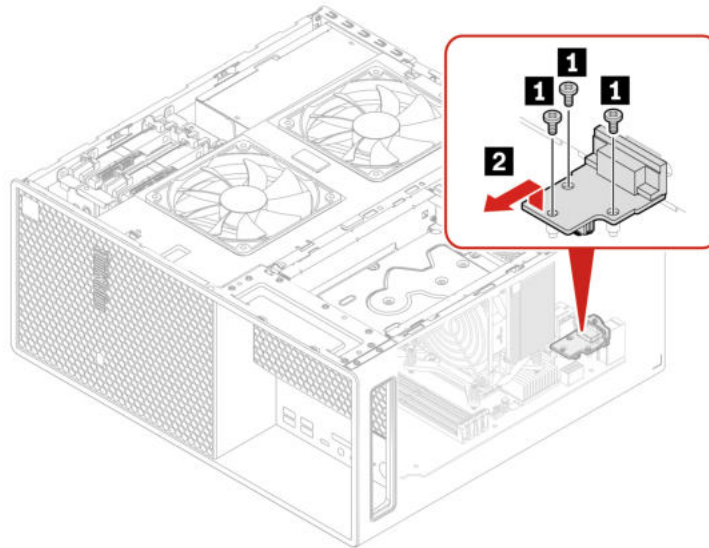

Step	Screw (quantity)	Torque
<b>1</b>	M3 × 3.2 mm, Nickel coated (3)	5.0 ± 0.5 in-lb

## Chassis beam

### Prerequisite

Before you start, read *Generic Safety and Compliance Notices*, and print the following instructions.

For access, remove these parts in order, if any:

- “Left side cover” on page 30
- “Side fan with bracket” on page 31
- “PCI-Express card bracket” on page 46
- “PCI-Express card” on page 47

## Replacement procedure

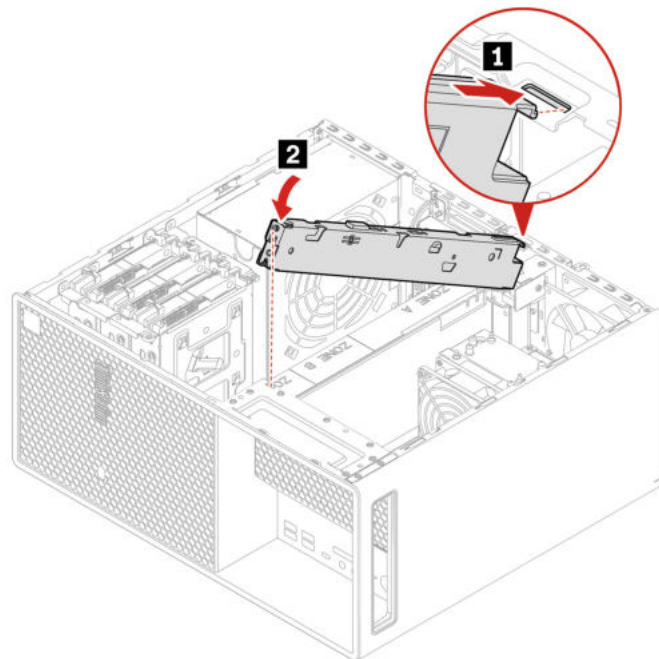
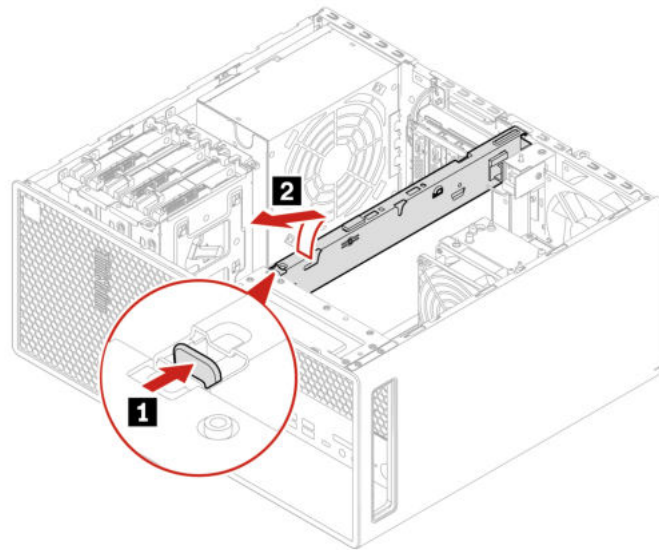

## Rear fan

### Prerequisite

Before you start, read *Generic Safety and Compliance Notices*, and print the following instructions.

For access, do the following:

1. Remove the “Left side cover” on page 30.
2. Disconnect the rear fan cable from the rear fan connector on the system board.

## Replacement procedure

**Note:** The rear fan is attached to the chassis by four rubber mounts. Stretch the tips of the rubber mounts and gently pull the rear fan assembly out of the chassis.

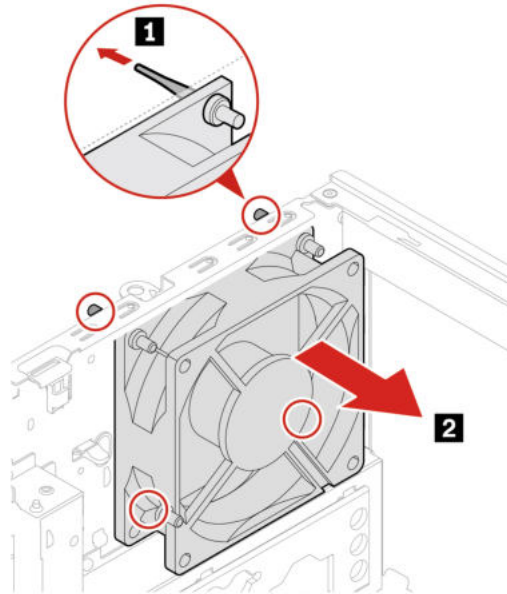

**Note:** Align the rubber mounts with the corresponding holes in the chassis and push the rubber mounts through the holes. Rotate and pull the tips of the rubber mounts until the rear fan assembly is secured.

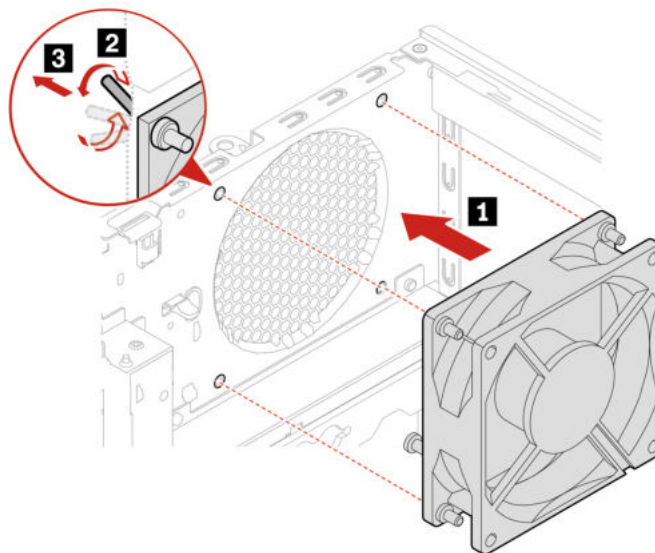

## Cover presence switch

### Prerequisite

Before you start, read *Generic Safety and Compliance Notices*, and print the following instructions.

For access, do the following:

1. Remove “Left side cover” on page 30.
2. Disconnect the cover presence switch cable from the system board.

### Removal steps

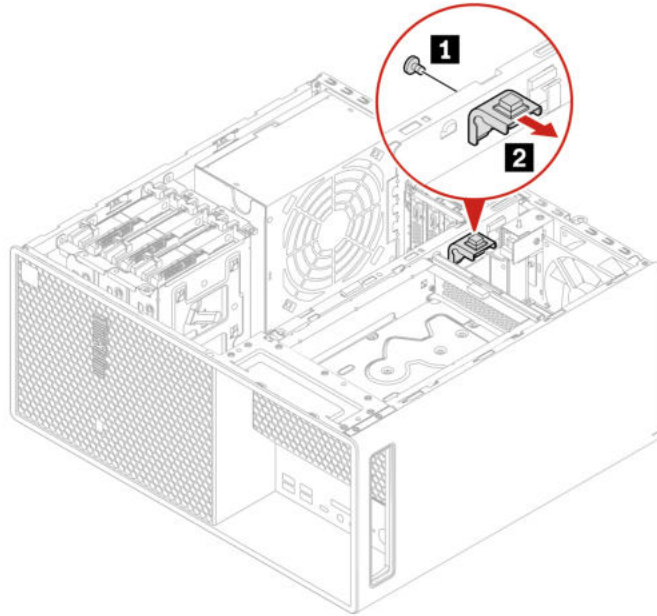

Step	Screw (quantity)	Torque
<b>1</b>	#6-32 × 5 mm, Nickel coated (1)	5.0 ± 0.5 in-lb

## Internal speaker

### Prerequisite

Before you start, read *Generic Safety and Compliance Notices*, and print the following instructions.

For access, do the following:

1. Remove the Left side cover.
2. Disconnect the internal speaker cable from the system board.

## Removal steps

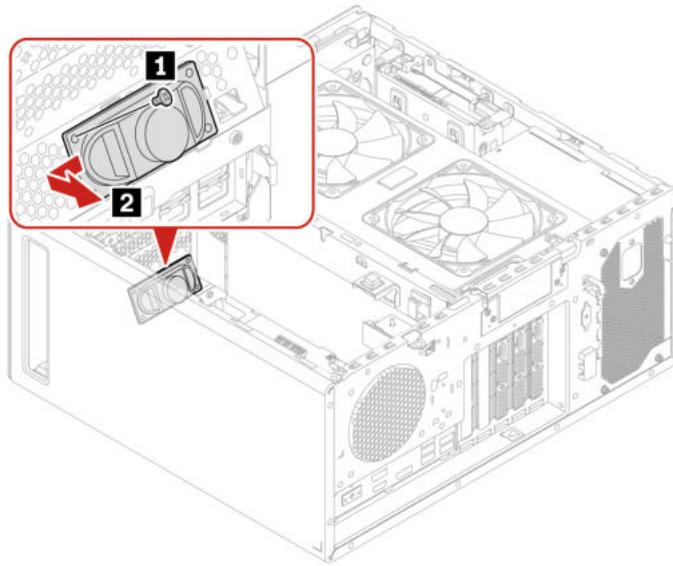

Step	Screw (quantity)	Torque
1	#6-32 × 5 mm, Nickel coated (1)	5.0 ± 0.5 in-lb

## Wi-Fi antenna cover

### Prerequisite

Before you start, read *Generic Safety and Compliance Notices*, and print the following instructions.

For access, remove the “Left side cover” on page 30.

## Removal steps

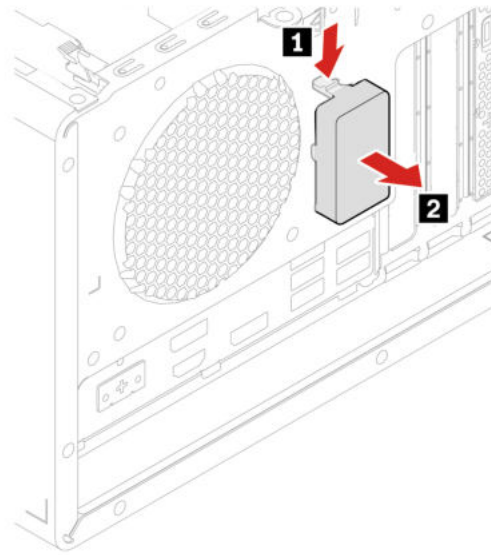

## M.2 solid-state drive and heat sink

### Prerequisite

Before you start, read *Generic Safety and Compliance Notices*, and print the following instructions.



Before you open the computer cover, turn off the computer and wait several minutes until the computer is cool.

**Attention:** The internal storage drive is sensitive. Inappropriate handling might cause damage and permanent loss of data. When handling the internal storage drive, observe the following guidelines:

- Replace the internal storage drive only for upgrade or repair. The internal storage drive is not designed for frequent changes or replacement.
- Before replacing the internal storage drive, make a backup copy of all the data that you want to keep.
- Do not touch the contact edge of the internal storage drive. Otherwise, the internal storage drive might get damaged.
- Do not apply pressure to the internal storage drive.
- Do not make the internal storage drive subject to physical shocks or vibration. Put the internal storage drive on a soft material, such as cloth, to absorb physical shocks.

### Removal steps

- Remove the “Left side cover” on page 30.
- Remove the M.2 solid-state drive and the heat sink.

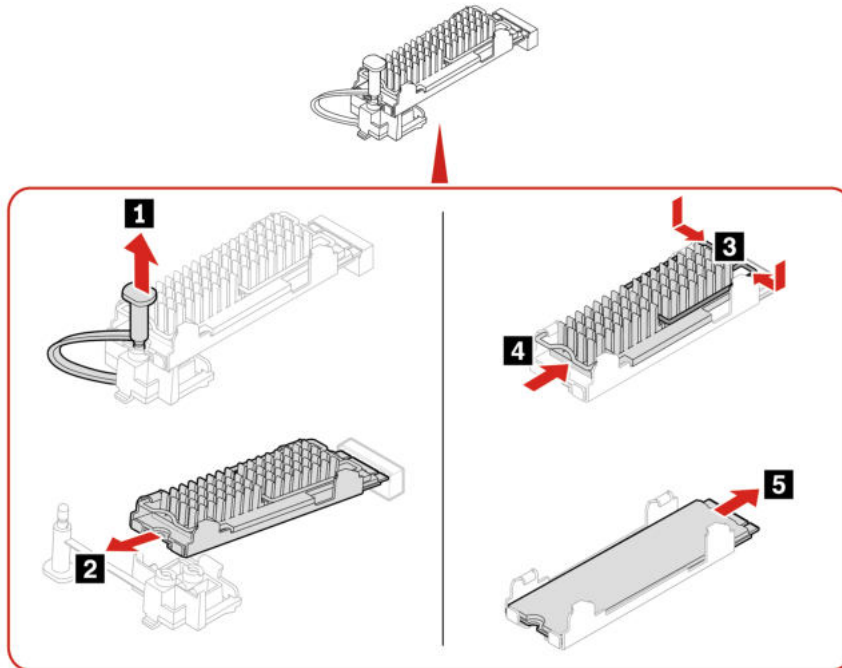

**Replacement procedure of the M.2 solid-state drive in an M.2 solid-state drive PCIe adapter**

1. Remove the “Left side cover” on page 30.
2. Locate and remove the M.2 solid-state drive PCIe adapter from the PCIe card slot. See “PCI-Express card” on page 47.
3. Replace the M.2 solid-state drive and the heat sink.

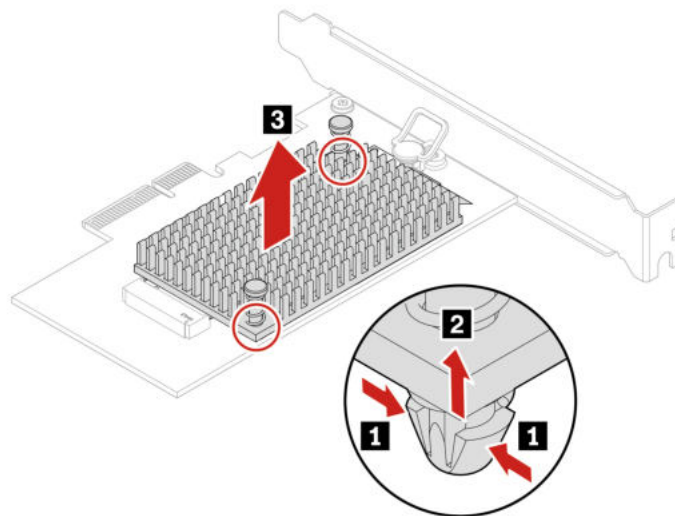

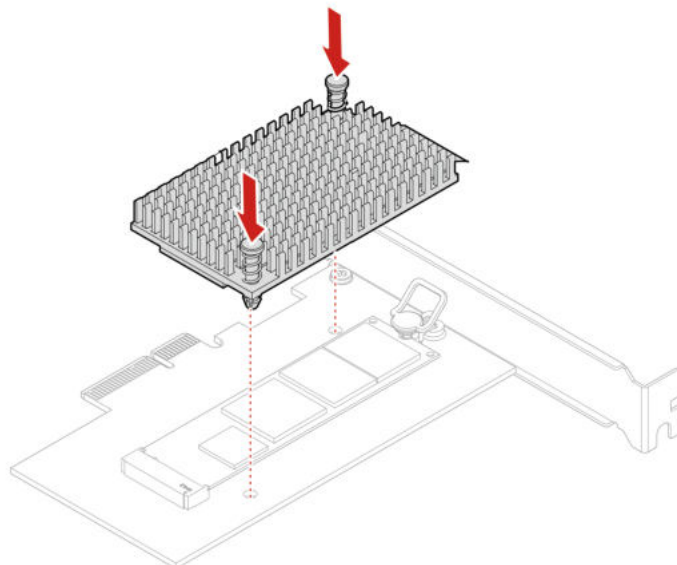
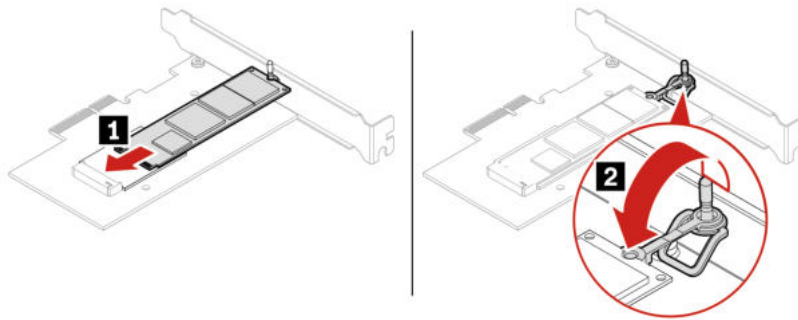
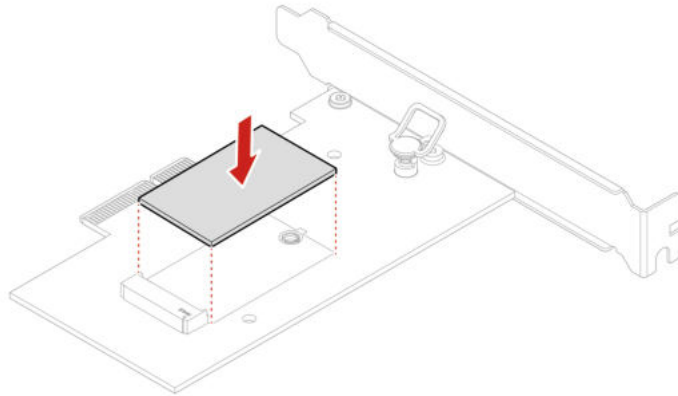
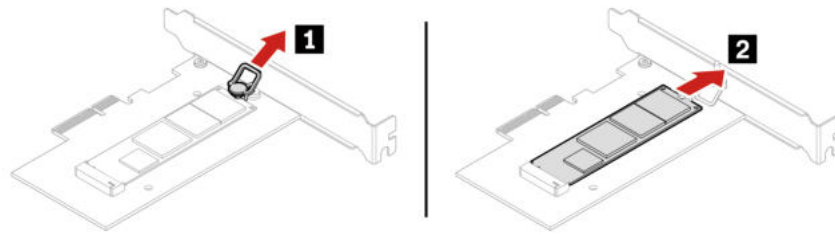



## M.2 solid-state drive bracket

### Prerequisite

Before you start, read *Generic Safety and Compliance Notices*, and print the following instructions.

For access, remove these parts in order, if any:

- “Left side cover” on page 30
- “M.2 solid-state drive and heat sink” on page 56

### Removal steps

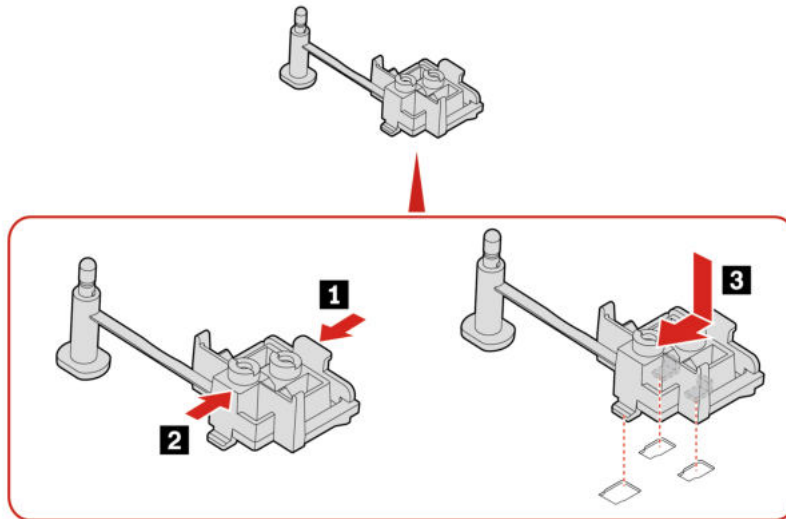

## Memory module

### Prerequisite

Before you start, read *Generic Safety and Compliance Notices*, and print the following instructions.

Ensure that you follow the installation order for memory modules shown in the following illustration.

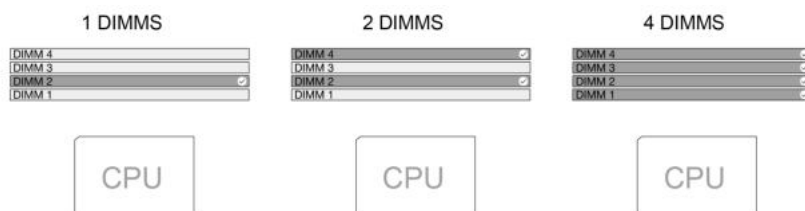

For access, remove the “Left side cover” on page 30.

## Replacement procedure

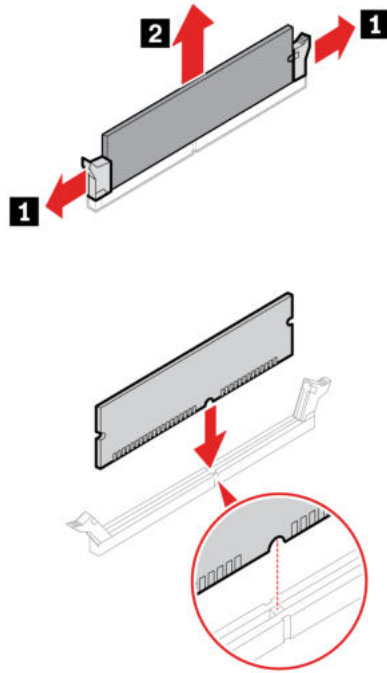

**Note:** During the installation, ensure that you align the memory module to the slot and press down on both ends until the latches are fully engaged with a click.

## E-lock

### Prerequisite

Before you start, read *Generic Safety and Compliance Notices*, and print the following instructions.

For access, do the following:

1. Remove the “Left side cover” on page 30.
2. Disconnect the E-lock cable from the system board.

**Note:** To remove the screws, you need a special tool (T15 star wrench).

### Removal steps

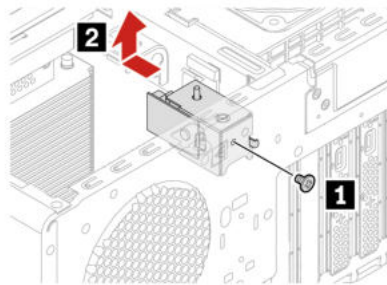

Step	Screw (quantity)	Torque
<b>1</b>	M3 × 5 mm, Nickel coated (1)	5.0 ± 0.5 in-lb

## Chassis rubber foot

### Prerequisite

Before you start, read *Generic Safety and Compliance Notices*, and print the following instructions.

### Removal steps

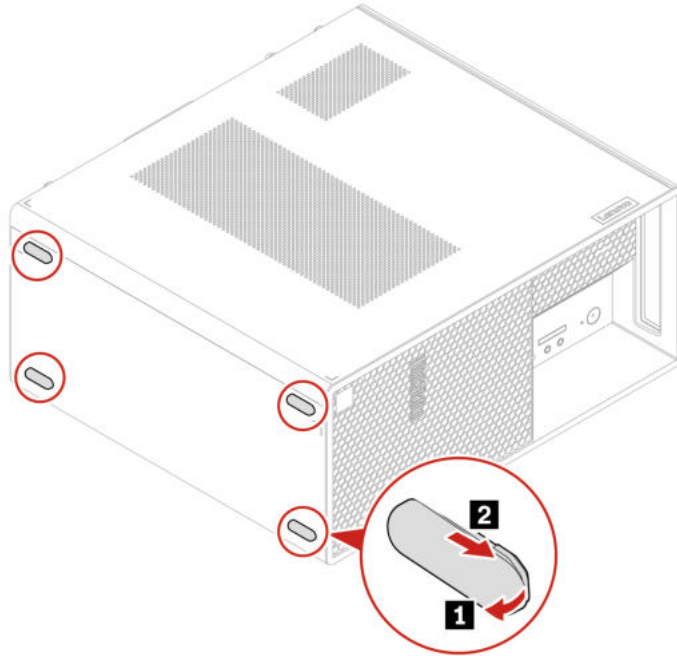



---

## Chapter 6. Help and support

---

### Self-help resources

Use the following self-help resources to learn more about the computer and troubleshoot problems.

Resources	How to access?
Troubleshooting and frequently asked questions	<ul style="list-style-type: none"><li>• <a href="https://www.lenovo.com/tips">https://www.lenovo.com/tips</a></li><li>• <a href="https://forums.lenovo.com">https://forums.lenovo.com</a></li></ul>
Accessibility information	<a href="https://www.lenovo.com/accessibility">https://www.lenovo.com/accessibility</a>
Reset or restore Windows	<ul style="list-style-type: none"><li>• Use Lenovo recovery options.<ol style="list-style-type: none"><li>1. Go to <a href="https://support.lenovo.com/HowToCreateLenovoRecovery">https://support.lenovo.com/HowToCreateLenovoRecovery</a>.</li><li>2. Follow the on-screen instructions.</li></ol></li><li>• Use Windows recovery options.<ol style="list-style-type: none"><li>1. Go to <a href="https://pcsupport.lenovo.com">https://pcsupport.lenovo.com</a>.</li><li>2. Detect your computer or manually select your computer model.</li><li>3. Navigate to the troubleshooting menu to diagnose the operating system for recovery instructions.</li></ol></li></ul>
Use the Vantage app to:	
<ul style="list-style-type: none"><li>• Configure device settings.</li><li>• Download and install UEFI BIOS, drivers and firmware updates.</li><li>• Secure your computer from outside threats.</li><li>• Diagnose hardware problems.</li><li>• Check the computer warranty status.</li><li>• Access <i>User Guide</i> and helpful articles.</li></ul>	Type Vantage in the Windows search box.
<b>Note:</b> The available features vary depending on the computer model.	
Product documentation:	
<ul style="list-style-type: none"><li>• <i>Safety and Warranty Guide</i></li><li>• <i>Generic Safety and Compliance Notices</i></li><li>• <i>Setup Guide</i></li><li>• <i>This User Guide</i></li><li>• <i>Regulatory Notice</i></li></ul>	Go to <a href="https://pcsupport.lenovo.com">https://pcsupport.lenovo.com</a> . Then, follow the on-screen instructions to filter out the documentation you want.

---

Resources	How to access?
Lenovo Support Web site with the latest support information of the following:	
<ul style="list-style-type: none"> <li>• Drivers and software</li> <li>• Diagnostic solutions</li> <li>• Product and service warranty</li> <li>• Product and parts details</li> <li>• Knowledge base and frequently asked questions</li> </ul>	<a href="https://pcsupport.lenovo.com">https://pcsupport.lenovo.com</a>
Windows help information	<ul style="list-style-type: none"> <li>• Type Get Help or Tips in the Windows search box.</li> <li>• Use Windows Search or the Cortana® personal assistant.</li> <li>• Microsoft support Web site: <a href="https://support.microsoft.com">https://support.microsoft.com</a></li> </ul>

## Call Lenovo

If you have tried to correct the problem yourself and still need help, you can call Lenovo Customer Support Center.

### Before you contact Lenovo

Prepare the following before you contact Lenovo:

1. Record the problem symptoms and details:
  - What is the problem? Is it continuous or intermittent?
  - Any error message or error code?
  - What operating system are you using? Which version?
  - Which software applications were running at the time of the problem?
  - Can the problem be reproduced? If so, how?
2. Record the system information:
  - Product name
  - Machine type and serial number

The following illustration shows where to find the machine type and serial number of your computer.

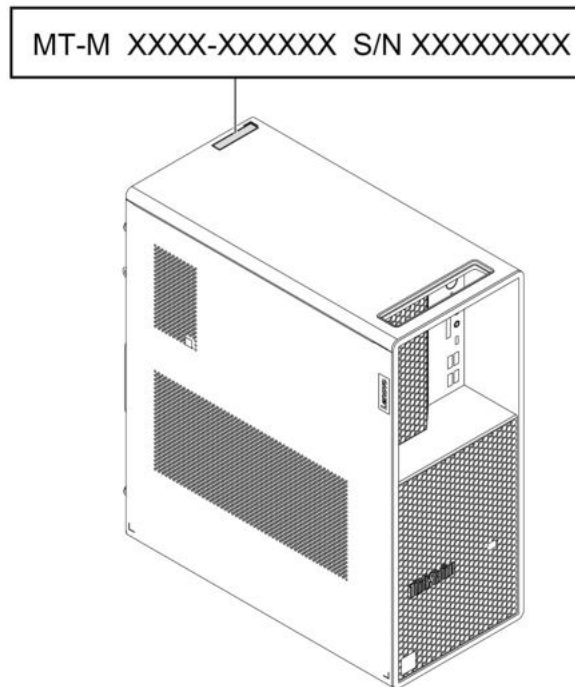

### Lenovo Customer Support Center

During the warranty period, you can call Lenovo Customer Support Center for help.

### Telephone numbers

For a list of the Lenovo Support phone numbers for your country or region, go to:  
<https://pcsupport.lenovo.com/supportphonenumberlist>

**Note:** Phone numbers are subject to change without notice. If the number for your country or region is not provided, contact your Lenovo reseller or Lenovo marketing representative.

---

## Certification-related information

**Product name:** ThinkStation P3 Tower

**Machine types:** 30GR, 30GS, 30GT, 30GU, 30GW, 30GX, 30GY, and 30GV

Further compliance information related to your product is available at <https://www.lenovo.com/compliance>.

---

## Compliance information

For more compliance information, refer to *Regulatory Notice* at <https://pcsupport.lenovo.com> and *Generic Safety and Compliance Notices* at [https://pcsupport.lenovo.com/docs/generic\\_notices](https://pcsupport.lenovo.com/docs/generic_notices).

---

## Purchase accessories

Lenovo has a number of hardware accessories and upgrades to help expand the capabilities of your computer. Options include memory modules, storage devices, network cards, power adapters, keyboards, mice, and more.

To shop at Lenovo, go to <https://www.lenovo.com/accessories>.

---

## **Purchase additional services**

During and after the warranty period, you can purchase additional services from Lenovo at:  
<https://pcsupport.lenovo.com/warrantyupgrade>

Service availability and service name might vary by country or region.



---

## Appendix A. Notices and trademarks

### Notices

Lenovo may not offer the products, services, or features discussed in this document in all countries. Consult your local Lenovo representative for information on the products and services currently available in your area. Any reference to a Lenovo product, program, or service is not intended to state or imply that only that Lenovo product, program, or service may be used. Any functionally equivalent product, program, or service that does not infringe any Lenovo intellectual property right may be used instead. However, it is the user's responsibility to evaluate and verify the operation of any other product, program, or service.

Lenovo may have patents or pending patent programs covering subject matter described in this document. The furnishing of this document does not give you any license to these patents. You can send license inquiries, in writing, to:

*Lenovo (United States), Inc.  
8001 Development Drive  
Morrisville, NC 27560  
U.S.A.  
Attention: Lenovo Director of Licensing*

LENOVO PROVIDES THIS PUBLICATION "AS IS" WITHOUT WARRANTY OF ANY KIND, EITHER EXPRESS OR IMPLIED, INCLUDING, BUT NOT LIMITED TO, THE IMPLIED WARRANTIES OF NON-INFRINGEMENT, MERCHANTABILITY OR FITNESS FOR A PARTICULAR PURPOSE. Some jurisdictions do not allow disclaimer of express or implied warranties in certain transactions, therefore, this statement may not apply to you.

Changes are made periodically to the information herein; these changes will be incorporated in new editions of the publication. To provide better service, Lenovo reserves the right to improve and/or modify the products and software programs described in the manuals included with your computer, and the content of the manual, at any time without additional notice.

The software interface and function and hardware configuration described in the manuals included with your computer might not match exactly the actual configuration of the computer that you purchase. For the configuration of the product, refer to the related contract (if any) or product packing list, or consult the distributor for the product sales. Lenovo may use or distribute any of the information you supply in any way it believes appropriate without incurring any obligation to you.

The products described in this document are not intended for use in implantation or other life support applications where malfunction may result in injury or death to persons. The information contained in this document does not affect or change Lenovo product specifications or warranties. Nothing in this document shall operate as an express or implied license or indemnity under the intellectual property rights of Lenovo or third parties. All information contained in this document was obtained in specific environments and is presented as an illustration. The result obtained in other operating environments may vary.

Lenovo may use or distribute any of the information you supply in any way it believes appropriate without incurring any obligation to you.

Any references in this publication to non-Lenovo Web sites are provided for convenience only and do not in any manner serve as an endorsement of those Web sites. The materials at those Web sites are not part of the materials for this Lenovo product, and use of those Web sites is at your own risk.

Any performance data contained herein was determined in a controlled environment. Therefore, the result obtained in other operating environments may vary significantly. Some measurements may have been made on development-level systems and there is no guarantee that these measurements will be the same on generally available systems. Furthermore, some measurements may have been estimated through extrapolation. Actual results may vary. Users of this document should verify the applicable data for their specific environment.

This document is copyrighted by Lenovo and is not covered by any open source license, including any Linux agreement(s) which may accompany software included with this product. Lenovo may update this document at any time without notice.

For the latest information or any questions or comments, contact or visit the Lenovo Web site:

<https://pcsupport.lenovo.com>

### **Trademarks**

Lenovo, Lenovo logo, ThinkStation, and ThinkStation logo are trademarks of Lenovo. Intel, Intel Xeon, Intel Core, and Thunderbolt are trademarks of Intel Corporation or its subsidiaries in the U.S. and/or other countries. Microsoft, Windows, and Cortana are trademarks of the Microsoft group of companies. DisplayPort is a trademark of the Video Electronics Standards Association. The term HDMI is a trademark or registered trademark of HDMI Licensing LLC in the United States and other countries. Wi-Fi and Miracast are registered trademarks of Wi-Fi Alliance. USB-C is a registered trademark of USB Implementers Forum. All other trademarks are the property of their respective owners.



**Lenovo**