



User's Manual

**Professional Rack Mount LCD Series
PR1000ELCDRT2U/PR1500ELCDRT2U/
PR2200ELCDRT2U/ PR3000ELCDRT2U**

K01-0000145-01

IMPORTANT SAFETY INSTRUCTIONS

This manual contains important instructions. Please read and follow all instructions carefully during installation and operation of the unit. Read this manual thoroughly before attempting to unpack, install, or operate the UPS.

CAUTION! The UPS must be connected to a grounded AC power outlet with fuse or circuit breaker protection. DO NOT plug the UPS into an outlet that is not grounded. If you need to power-drain this equipment, turn off and unplug the unit.

CAUTION! The battery can power hazardous components inside the unit, even when the AC input power is disconnected.

CAUTION! The UPS should be near the connected equipment and easily accessible.

CAUTION! To prevent the risk of fire or electric shock, install in a temperature and humidity controlled indoor area, free of conductive contaminants. (Please see specifications for acceptable temperature and humidity range).

CAUTION! To reduce the risk of an electric shock, do not remove the cover, except to service the battery. There are no user serviceable parts inside, except for the battery.

CAUTION! To avoid electrical shock, turn off the unit and unplug it from the AC power source before servicing the battery or installing a computer component.

CAUTION! To reduce the risk of fire, connect the UPS to a circuit with 16 amperes maximum over-current protection in accordance to CE requirement.

CAUTION! The AC outlet where the UPS is connected should be close to the unit and easily accessible.

CAUTION! Please use only VDE-tested, CE-marked mains cable, (e.g. the mains cable of your equipment), to connect the UPS to the AC outlet.

CAUTION! Please use only VDE-tested, CE-marked power cables to connect any equipment to the UPS.

CAUTION! When installing the equipment, ensure that the sum of the leakage current of the UPS and the connected equipment does not exceed 3.5mA.

CAUTION! This is permanently connected equipment and only qualified maintenance personnel may carry out installations.

CAUTION! Do not unplug the unit from AC Power during operation, as this will invalidate the protective ground insulation.

CAUTION! DO NOT USE FOR MEDICAL OR LIFE SUPPORT EQUIPMENT! Under no circumstances this unit should be used for medical applications involving life support equipment and/or patient care.

CAUTION! DO NOT USE WITH OR NEAR AQUARIUMS! To reduce the risk of fire, do not use with or near aquariums. Condensation from the aquarium can come in contact with metal electrical contacts and cause the machine to short out.

CAUTION! DO NOT USE WITH LASER PRINTERS! The power demands of laser printers are too large for a UPS.

DO NOT INSTALL THE UPS WHERE IT WOULD BE EXPOSED TO DIRECT SUNLIGHT OR NEAR A STRONG HEAT SOURCE!

DO NOT BLOCK OFF VENTILATION OPENINGS AROUND THE HOUSING!

DO NOT CONNECT DOMESTIC APPLIANCES SUCH AS HAIR DRYERS TO UPS OUTPUT SOCKETS.

INSTALLING YOUR UPS SYSTEM

UNPACKING

The box should contain the following:

(1) UPS unit x 1; (2) User manual x 1; (3) Phone line x 1; (4) PowerPanel® Business Edition software CD x 1; (5) USB A+B type cable x 1; (6) Rack mount Brackets x 2; (7) Emergency Power Off Cable (gray) x 1; (8) Serial Interface Cable (DB-9) x 1; (9) Power cord x 5

AUTOMATIC VOLTAGE REGULATOR(AVR)

The **PR1000ELCDRT2U/RE1500LCDRT2U/RE2200LCDRT2U** can stabilize the consistent utility power. The utility power may be damaging to important data and hardware, but Automatic Voltage Regulation helps the computer not experience dangerous voltage levels. Automatic Voltage Regulator automatically regulates low or high voltages to keep equipment working at safe AC power levels (220/230/240V) without switching to battery. Your equipment can operate normally even meet the power problems, such as, short brownouts and blackouts. The unit's powerful sealed lead-acid batteries will provide power only if the incoming voltage drops below 150V or increases above 300V.

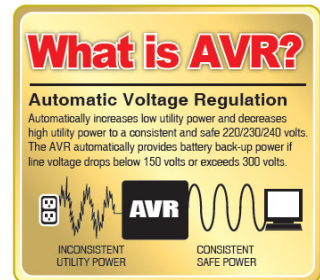

INSTALLING YOUR UPS SYSTEM (continued)

SYSTEM BLOCK DIAGRAM

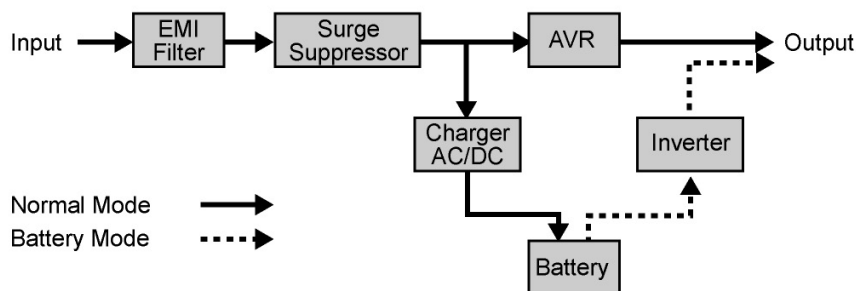

HARDWARE INSTALLATION GUIDE

1. Battery charge loss may occur during shipping and storage. For the first time the UPS is used, it's strongly recommended to charge batteries for at least eight hours is recommended to ensure that the batteries' maximum charge capacity. To recharge the batteries, simply make the UPS plugs into an AC outlet.
2. When you use the included software, connect either the serial or the USB cable between the computer and the corresponding port on the UPS. **Note:** If the USB port is used, the serial port will be disabled. They cannot be used simultaneously. The computer with the PowerPanel® Business Edition S/W connects to the USB port or the Serial port on the UPS. It can control the operating schedule, battery test, outlet, etc. and get information on the UPS status. However, other computers with PowerPanel® Business Edition S/W can only get UPS status information via a LAN connection.
3. With the UPS off and unplugged, connect your computer, monitor, and any externally powered data storage device (Hard drive, Tape drive, etc.) into the outlets. **DO NOT** plug a laser printer, copier, space heater, vacuum, paper shredder or other large electrical device into the UPS. The power demands of these devices will overload and possibly damage the unit.
4. To protect a fax, telephone, modem line or network cable, connect the telephone or network cable from the wall jack outlet to the jack marked "IN" of the UPS. Then, connect a telephone cable or network cable from the jack marked "OUT" on the UPS to the modem, computer, telephone, fax machine, or network device.

INSTALLING YOUR UPS SYSTEM (continued)

5. Press the power switch to turn the UPS on. The Power-On indicator light will illuminate. If an overload is detected, an audible alarm will sound and the UPS will emit one long beep. In order to reset it, turn the unit off and unplug some equipment from outlets. Make sure your equipment carry a load current within the unit's safe range, (refer to the technical specifications), and then turn the unit on.

6. Your UPS is equipped with an auto-charge feature. When the UPS is plugged into an AC outlet, the battery will be automatically charging, even when the unit is switched off!

7. To always maintain an optimal battery charge, leave the UPS plugged into an AC outlet at all times.

8. Before storing the UPS for an extended period of time, turn the unit OFF. Then cover it and store it with the batteries fully charged. Recharge the batteries every three months or so, to ensure good battery capacity and long battery life; further, this might also prevent damage to the unit from an unlikely battery leakage.

9. The unit provides one Primary Serial Port (I), Secondary Serial Port (II), and one USB port, (paired with the Primary Serial Port), to allow connection and communication between the unit and any attached computers. The Primary Serial Port (I) as well as its paired USB port allow for bi-directional communication among the UPS and the primary connected computer running the PowerPanel® Business Edition S/W provided. The UPS can control the computer's shutdown in case of an emergency, and at the same time, the computer can monitor the UPS and alter its various programmable parameters. On the other hand, secondary Serial Port II, only allows the UPS to initiate the connected computer's graceful auto-shutdown in case of an emergency.

10. EPO (Emergency Power Off) Port:

Use the provided gray cable to connect to a special EPO contact switch. Follow the appropriate circuit diagram below to wire the cable to your EPO configuration. The EPO remote switch is a switch installed in an outside area, connected to the unit via an ordinary RJ-11 phone line. In case of an emergency, it can be used to immediately cut-off power from the UPS unit.

BASIC OPERATION

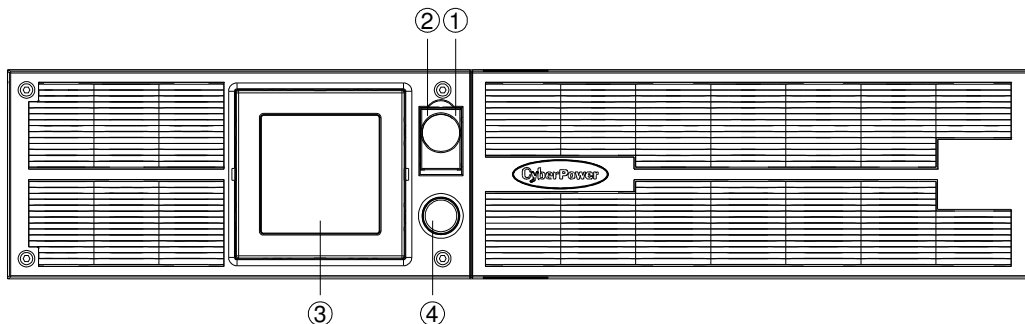

FRONT / REAR PANEL DESCRIPTION

1. Power Switch

Master on/off switch for equipment connected to the UPS.

2. Power On Indicator

Indicate that the AC utility input power's condition is normal and that the UPS outlets are providing power, free of surges and spikes.

3. Multifunction LCD Readout

An LCD that shows various UPS information using icons and messages.

4. LCD Readout Toggle Button

Used to select among a variety of information the LCD can display.

BASIC OPERATION (continued)

PR1000ELCDRT2U
PR1500ELCDRT2U

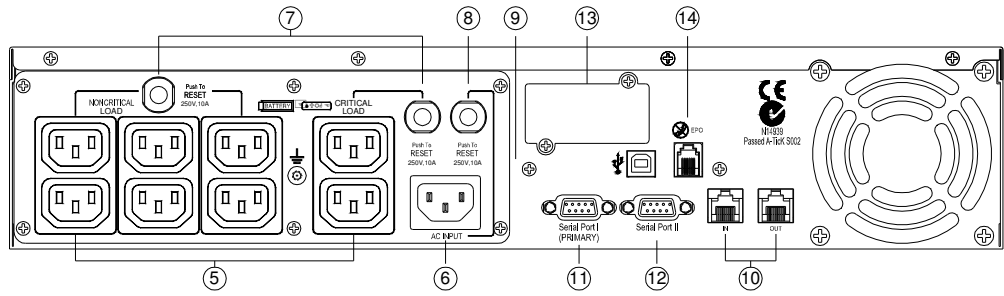

PR2200ELCDRT2U
PR3000ELCDRT2U

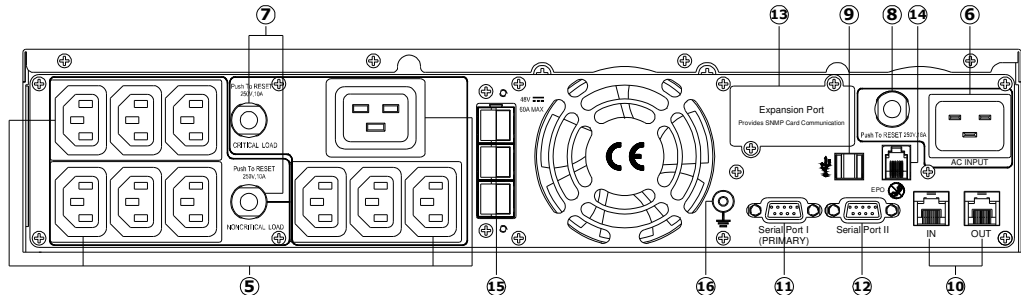

5. Battery Backup, Surge Protected and AVR protected Outlets

This unit provides a total of six outlets with battery backup and surge protection. They ensure that connected equipment will keep an uninterrupted operation over a period of time, during a power failure.

Critical /Non-critical

It is possible to program the unit in a way so that the outlet block marked as “non-Critical”, will stop the provision of power to connected equipment after a certain period of time, thus making more runtime available for the equipment connected on the outlets marked as “Critical”. In other words, the user can establish runtime priority for certain connected equipment, maximizing its “availability” during a prolonged power outage. This type of control takes place with the use of the provided PowerPanel® Business Edition S/W.

6. AC Inlet

Connect the AC Power cord to a properly wired and grounded outlet.

7. Output Circuit Breaker

The circuit breaker serves to provide output overload and fault protection.

8. Input Circuit Breaker

The circuit breaker serves to provide input overload and fault protection.

9. USB port to PC

This is a connectivity port allowing communication and control among the UPS and the connected computer. You should install on your computer the PowerPanel® Business Edition software appropriate to the operating system you are using.

10. Surge Protected Communication Ports - RJ11/RJ45

These ports are being used to protect from various surge-conditions the standard RJ-45/RJ-11 based, (ADSL, LAN, Phone/Modem-Lines), cabling systems.

11. Serial Port I (Primary)

Serial port I allow for bi-directional communication among the UPS and the computer. The UPS can control the computer’s shutdown in case of an emergency, and at the same time, the computer can monitor the UPS and alter its various programmable parameters.

12. Serial Port II (Secondary)

Serial Port II allows the UPS to initiate the connected computer’s graceful auto-shutdown in case of an emergency.

13. SNMP/HTTP Network slot

Remove the cover panel to install optional SNMP, allowing your UPS be controlled and monitored via a network connection.

14. EPO (Emergency Power Off) Port

Allow for an emergency UPS Power-Off from a remote location.

BATTERY REPLACEMENT

Read and follow the IMPORTANT SAFETY INSTRUCTIONS before servicing the batteries:

Servicing the batteries should only be performed by professionals. Please Contact your dealer, or email to: service@cyberpower-eu.com. Make a note for the replacement battery pack number, **(RBP832)**, regarding PR1000ELCDRT2U and PR1500ELCDRT2U models; **(RBP842)**, regarding PR2200ELCDRT2U model.

CAUTION! Use only the specified type of battery: **BP7-12** for PR1000ELCDRT2U/PR1500ELCDRT2U, HR9-12 for PR2200ELCDRT2U. Contact your dealer for replacement batteries.

CAUTION! The battery may present the risk of electrical shock. Do not dispose of batteries on fire, since they may explode. Follow all local ordinances regarding the proper disposal of batteries.

CAUTION! Do not open or mutilate the batteries. Released electrolyte is harmful to the skin and eyes and may be toxic.

CAUTION! A battery can present a high risk of short-circuits and electrical shocks.

Take the following precautions before replacing the battery:

1. Remove all watches, rings or other metal objects from your hands.
2. Only use tools with insulated handles.
3. DO NOT lay tools or other metal parts on top of battery or any battery terminals.
4. Wear rubber gloves and shoes.
5. Determine if the battery is grounded. If so, remove source of ground. **CAUTION: CONTACT WITH A GROUNDED BATTERY CAN RESULT IN ELECTRICAL SHOCK!** The likelihood of such a shock will be greatly reduced if such grounding is removed during installation and maintenance.

BATTERY REPLACEMENT (continued)

BATTERY REPLACEMENT PROCEDURE:

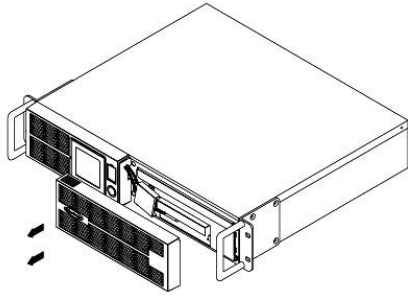

1. Remove the front panel on the right side.

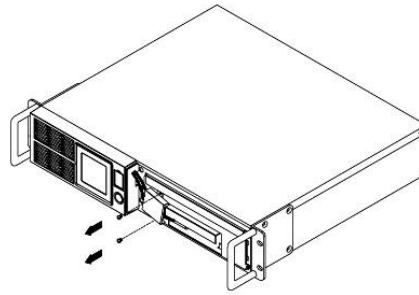

2. Remove the two retaining screws of the cable protection cover then remove the cover.

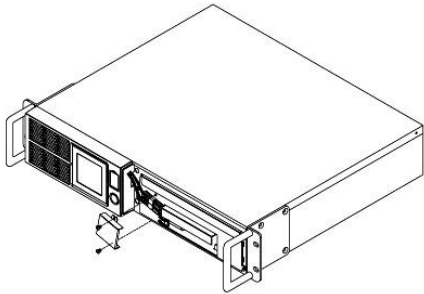

3. Remove the two retaining screws of the cable connectors.

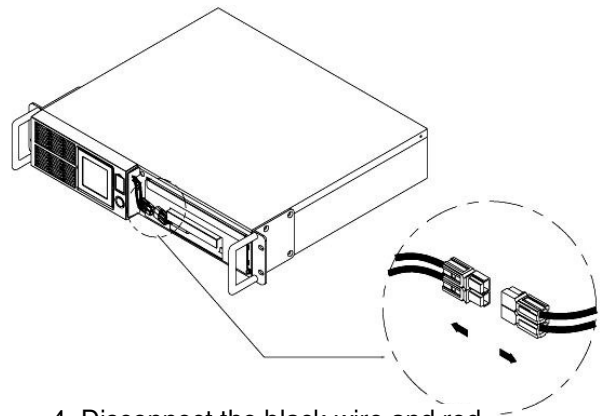

4. Disconnect the black wire and red wire from the battery.

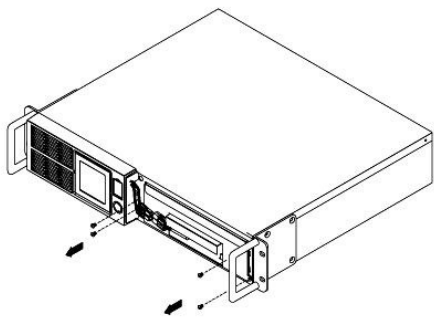

5. Remove the three retaining screws.

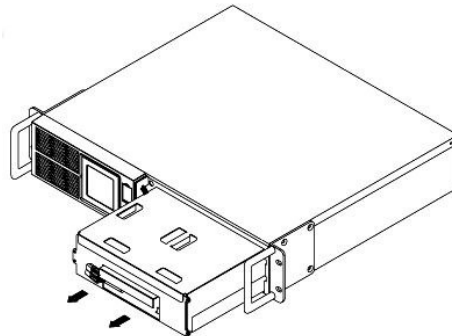

6. Put the new battery packs back into the compartment. Tighten up the screws and replace the cable protection cover and the front panel. Recharge the unit for 8 hours to ensure the UPS performs expected runtime.

REMINDER! The used batteries are hazardous wastes and must be disposed through recycling. Most retailers that sell lead-acid batteries collect used batteries for recycling, as required by the local regulations.

DEFINITION FOR ILLUMINATED LCD INDICATORS

1. **Input voltage meter:** This meter measures the AC voltage from the wall outlet. The INPUT voltage readout is used to identify the input voltage information. This can be used as a diagnostic tool to identify poor-quality input power. Units are listed in V (Volts). When the UPS connect to any equipment, the AVR can provide a stable 220/230/240V power output. In the event of a complete loss of power, severe brownout, or over voltage, the UPS relies on its internal battery to back up to supply a consistent 220/230/240V output.

2. **Output voltage meter:** The Output Voltage screen measures, in real time, the AC voltage that the UPS is providing to your connected equipment via the UPS outlets. Units are listed in V (Volts).

3. **Estimate run time:** The Estimated Runtime Screen displays how many minutes of runtime can be expected of the UPS if it were to experience a power outage. When runtime becomes shorted, the battery capacity will decrease; (battery capacity bar indicator will be falling.) **Note:** The number displayed may be less than actual runtimes for low loads.

4. **Normal icon:** This icon illuminates when the UPS is working under normal conditions.

5. **Battery icon:** When there is a severe brownout or blackout, this icon will appear followed by an alarm, (two short beeps), indicating that the UPS is now working using its internal batteries. Once the batteries are run out of power, (over a period of time), a constant alarm will sound. If this happens and main power has not been restored, it is recommended that you save your files and turn off your equipment manually as soon as possible.

6. **Automatic Voltage Regulation (AVR) icon:** This icon will appear when the unit is automatically regulating low or high AC input line voltage conditions, without resulting to the use of battery power.

7. **Silent mode icon:** This icon appearing indicates that the buzzer will not be beeping while in battery operating mode. During Silent mode, the unit's alarm does not sound until the Battery Capacity falls to < 20%.

8. **Over load icon:** This icon will appear followed by an alarm, indicating that an overload condition has been reached. To recover from the overload condition, start unplugging your equipment from the UPS outlets until the icon disappears and the alarm stops.

9. **Fault icon:** When activated indicates a system fault error. Please refer to the troubleshooting table for possible causes and solutions.

10. **BATT. CAPACITY:** BATT. CAPACITY is shown as a bar chart; each segment indicates approximately a 20% of battery capacity.

11. **LOAD CAPACITY:** Load CAPACITY is shown as a bar chart; each segment indicates approximately a 20% of load capacity.

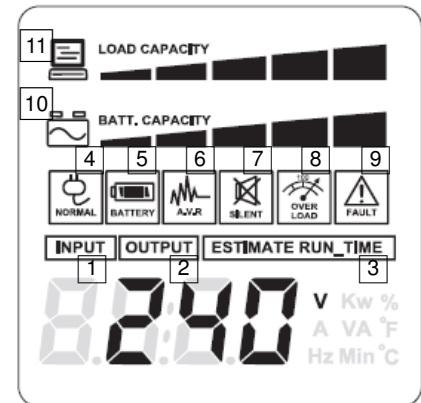

The LCD displays detailed information on the UPS status and current power conditions to alert you to potential power problems before they affect your equipment. Note! All related UPS information is based on that you should turn on the UPS.

LCD SETUP FUNCTIONS

1. General Mode:

- a. Press the “Display-Toggle” button to check the status of the UPS status:

	Item	Unit
1	Input Voltage	V
2	Output Voltage	V
3	Output Frequency	Hz
4	Load	Kw
5	Estimate Run Time	Min
6	Load Capacity	%
7	Battery Capacity	%
8	Centigrade	°C
9	Fahrenheit	°F

- b. Press and hold the “Display-Toggle” button for 4 seconds,
If the machine is in the Battery Mode with active alarm, it will become silent.
If the machine is in the Line Mode, a self- diagnostic test will take place.

- c. If the “Display-Toggle” button remains untouched for over 30 seconds, the LCD backlight will turn off automatically.

2. Set-up Mode

Step 1: Hold the “Display-Toggle” button for 10 seconds to enter the UPS Set-Up Mode.

Step 2: By pressing the Display toggle, users can switch between setup functions. Some User Configurable functions are as follows:

- a. Delay Time: The time delay between switching from Battery Mode to Line Mode. There are 9 different settings. The default setting is 0 minutes.
- b. Battery Pack Numbers: This function provides the estimated UPS runtime using various numbers of battery packs. The default setting is 0.
- c. Static Frequency Tolerance: There are 4 settings (1,2,4,6 %), and the default setting is +/-6%. Functional description: The setting may be adjusted to the quality of the electricity in use.
- d. Slew rate: Also known as Dynamic Frequency Tolerance. There are 5 different settings (0.25,0.5,1,2,4 Hz/Sec). The fault value is 4Hz/sec. Functional Description: “Slew Rate” indicates the tolerance of a device in accepting frequency variance. Lower “Slew Rate” results in less tolerance but better protection for the connected load and vice versa.
- e. Low Battery Shutdown Voltage: This function will adjust the UPS shutdown point according to the battery’s remaining capacity.

These programmable items are sorted by unit as in the following table :

Items	Unit
Delay Time	Min
Battery Pack Numbers	A
Voltage Mode (220/230/240)	V
Static Frequency Tolerance	%
Slew Rate	Hz
Low Battery Shutdown Voltage	V
Firmware Version	None

Step 3: Press and hold the display-toggle for 4 seconds. When the icons blink, the value of each item is changed by slightly pressing the toggle.

LCD SETUP FUCTIONS

Step 4: To save the value and return to general mode, press and hold the toggle for 4 seconds.

Note! If the UPS is left idle for over 30 seconds during setup, it will turn off the backlight and return to general mode automatically.

Note! If the user does not want to save the new settings and return to the general mode, there are two methods:

- (1) Wait for the backlight to turn off, or,
- (2) By pressing and holding the "Display-toggle" key for 10 second.

CYBERPOWER GREENPOWER UPS™ TECHNOLOGY

GreenPower UPS™

CyberPower's GreenPower UPS™ Circuit Design is a solution to this problem "Power Loss." When the Utility Power is operating normally, Green Power UPS™ works in Bypass Mode.

Our GreenPower UPS™ design conducts power only through the Relay and still provides normal output voltage. Bypassing the transformer reduces power consumption thereby conserving energy and saving money. When the utility power is abnormal the UPS will operate under Battery or AVR Mode. Under this condition Green Power UPS™ and a traditional UPS would operate about the same.



On average utility power operates 88% of the time and the CyberPower GreenPower Technology will work in its money/ energy saving Bypass Mode.

TECHNICAL SPECIFICATIONS

Model	PR1000ELCDRT2U	PR1500ELCDRT2U	PR2200ELCDRT2U	PR3000ELCDRT2U
Capacity (VA)	1000	1500	2200	3000
Capacity (Watts)	700	1000	1600	2250
Input				
Input connections	IEC 320 C14		IEC 320 C20	
Nominal Input Voltage	220Vac – 240Vac			
Input Voltage Range	160Vac – 290Vac			
Input Frequency Range	50/60Hz +/- 3Hz (Auto Sensing)			
Output				
On Battery Output Voltage	240Vac +/- 5%			
On Battery Output Frequency	50/60Hz +/- 0.1Hz			
Transfer Time (Typical)	4ms			
Overload Protection	On Utility: Circuit Breaker, On Battery: Internal Current Limiting			
Surge Protection and Filtering				
Lightning / Surge Protection	Yes			
Internet Ready (DSL / Phone / FAX / Modem Protection)	RJ11/RJ45 (One In/ One Out)			
Physical				
Output Receptacles	IEC C13 (8)		IEC C13 (9), IEC C19 (1)	
Dimensions(cm)	2U Rack, 43.3 x 8.8 x 38.8			43.3 x 8.8 x 48
Weight (kg)	25.5	27	30	37
Battery				
Sealed Maintenance Free Lead Acid Battery	12V / 7.0AH x4		12V / 9.0AH x4	
Hot Swappable External Battery	Yes			
Warning Diagnostics				
Indicators	Power On, LCD Display (Using Battery, AVR, Load Level, Battery Level)			
Audible Alarms	On Battery, Low Battery, Overload			
Environmental				
Operating Temperature	32°F to 104°F (0°C to 40°C)			
Operating Relative Humidity	0 to 95% Non-Condensing			
Communication				
PowerPanel [®] Business Edition Software	Windows 98/ME/NT/2000/XP, Vista, Windows 7			
Management				
Self -Test	Manual Self-Test			
Auto-Charger /Auto-Restart	Yes			
COM Interface	True RS232 x 1+ Contact Closure x 1			
Built- in USB interface	Yes			
SNMP/HTTP Networking	Optional			

TROUBLE SHOOTING

Problem	Possible Cause	Solution
Outlet does not provide power to equipment	Circuit breaker has tripped due to an overload.	Turn the UPS off and unplug at least one piece of equipment. Wait 10 seconds, reset the circuit breaker and then turn the UPS on.
	Batteries are discharged	Recharge the unit for at least 4 hours
	Unit has been damaged by a surge or spike.	Contact CyberPower Systems about replacement batteries at service@cpsww.com.au
	Uncritical outlets have turned off automatically due to an overload.	Push the toggle button to make the uncritical outlets turn on.
The UPS does not perform expected runtime.	Batteries are not fully charged.	Recharge the batteries by leaving the UPS plugged in.
	Batteries are degraded	Contact CyberPower Systems about replacement batteries at service@cpsww.com.au
The UPS will not turn on.	The on/off switch is designed to prevent damage by rapidly turning it off and on.	Turn the UPS off. Wait 10 seconds and then turn the UPS on.
	The unit is not connected to an AC outlet.	The unit must be connected to a 220/230/240v outlet.
	The batteries have degraded.	Contact CyberPower Systems about replacement batteries at service@cpsww.com.au
	Mechanical problem.	Contact CyberPower Systems at service@cpsww.com.au
PowerPanel® Personal Edition is inactive.	The serial cable or USB cable is not connected.	Connect the cable to the UPS unit. You must use the cable that came with the unit.
	The cable is connected to the wrong port.	Try another port of your computer.
	The unit is not providing power of batteries.	Shutdown your computer and turn the UPS off. Wait 10 seconds and turn the UPS back on. This should reset the unit.
	The serial cable is not the cable that was provided with the unit.	You must use the cable included with the unit for the Software.

For more information, visit www.cpsww.com.au or contact
CyberPower Systems Australia
 E-MAIL: service@cpsww.com.au

