

100-04063-AO

Calix® 100-04063 Compatible TAA Compliant 1000Base-BX 2-Channel SFP Transceiver (SMF, 1490nmTx/1310nmRx, 40km, LC, -40 to 85C)

Features

- INF-8074 and SFF-8472 Compliance
- Simplex LC Connector
- Industrial Temperature -40 to 85 Celsius
- Single-mode Fiber
- Hot Pluggable
- Excellent ESD Protection
- Metal with Lower EMI
- RoHS Compliant and Lead Free



Applications

- 1x Fibre Channel
- 1000Base-BX Ethernet
- Access (FTTx) and Enterprise

Product Description

This Calix® 100-04063 compatible SFP transceiver provides 1000Base-BX 2-Channel throughput up to 40km over single-mode fiber (SMF) using a wavelength of 1490nmTx/1310nmRx via an LC connector. It is guaranteed to be 100% compatible with the equivalent Calix® transceiver. This easy to install, hot swappable transceiver has been programmed, uniquely serialized and data-traffic and application tested to ensure that it will initialize and perform identically. Digital optical monitoring (DOM) support is also present to allow access to real-time operating parameters. This transceiver is Trade Agreements Act (TAA) compliant. We stand behind the quality of our products and proudly offer a limited lifetime warranty.

AddOn's transceivers are RoHS compliant and lead-free.

TAA refers to the Trade Agreements Act (19 U.S.C. & 2501-2581), which is intended to foster fair and open international trade. TAA requires that the U.S. Government may acquire only "U.S. – made or designated country end products."



Regulatory Compliance

- ESD to the Electrical PINs: compatible with MIL-STD-883E Method 3015.4
- ESD to the LC Receptacle: compatible with IEC 61000-4-3
- EMI/EMC compatible with FCC Part 15 Subpart B Rules, EN55022:2010
- Laser Eye Safety compatible with FDA 21CFR, EN60950-1& EN (IEC) 60825-1,2
- RoHS compliant with EU RoHS 2.0 directive 2015/863/EU

Absolute Maximum Ratings

Parameter	Symbol	Min.	Typ.	Max.	Unit
Maximum Supply Voltage	Vcc	-0.5		3.6	V
Storage Temperature	TS	-40		85	°C
Operating Case Temperature	Tc	-40		85	°C
Operating Relative Humidity	RH			95	%
Data Rate	FE		100		Mbps
	OC-3/STM-1		155		Mbps
	STM-4		622		Mbps
	FC		1063		Mbps
	GBE		1250		Mbps

Electrical Characteristics (TOP=25°C, Vcc=3.3Volts)

Parameter	Symbol	Min.	Typ.	Max.	Unit	Notes
Power Supply Voltage	Vcc	3.15	3.3	3.45	V	
Power Supply Current	Icc			300 per channel	mA	
Transmitter						
LVPECL Compatible Inputs (Differential)	Vin	400		2000	mVpp	AC coupled inputs (Note 5)
Input Impedance (Differential)	Zin	85	100	115	ohm	Rin > 100 kohm @DC
TX_FAULT	Fault	2		Vcc+0.3	V	
	Normal	0		0.5		
TX_Dis	Disable	2		Vcc+0.3	V	
	Enable	0		0.8		
Receiver						
CML Outputs (Differential)	Vout	400		800	mVpp	AC coupled outputs (Note 5)
Output impedance (Differential)	Zout	85	100	115	ohm	
RX_LOS	LOS	2		Vcc+0.3	V	
	Normal	0		0.8	V	
MOD_DEF (0:2)	VoH	2.5			V	With Serial ID
	VoL	0		0.5	V	

Optical Characteristics

Parameter	Symbol	Min	Typ	Max	Unit	Notes
9µm Core Diameter SMF	L		40		km	
Data Rate			100~1250		Mbps	
Transmitter						
Center Wavelength	λ_c	1480	1490	1500	nm	
Spectral Width (-20dB)	$\Delta\lambda$			1	nm	
Average Output Power	P _{out}	-5		0	dBm	1
Extinction Ratio @ 1250Mbps	ER	6			dB	
Side Mode Suppression Ratio	SMSR	30			dB	
Rise/Fall Time (20%~80%)	T _r /t _f			0.26	ns	
Output Optical Eye (Note 2)	Compliant with IEEE 803ah-2004					5
TX_Disable Assert Time	t _{off}			10	us	
P _{out} @TX_Disable Asserted	P _{out}			-45	dBm	
Receiver						
Center Wavelength	λ_c	1260	1310	1360	nm	
Receiver Sensitivity @1250Mbps	P _{min}			-24	dBm	4
Receiver Overload	P _{max}	-3			dBm	
Return Loss		12			dB	
Optical Path Penalty				1	dB	
LOS De-Assert @1250Mbps	LOSD			-25	dBm	
LOS Assert	LOSA	-35			dBm	
LOS Hysteresis		0.5			dB	6

Notes:

1. Output is coupled into a 9/125µm single-mode fiber.
2. Filtered measured with a PRBS 2⁷-1.
3. LVPECL logic, internally AC coupled.
4. Minimum average optical power measures at BER less than 1E-12, with a 2⁷-1 PRBS and ER=9 dB

5. Eye Pattern Mask

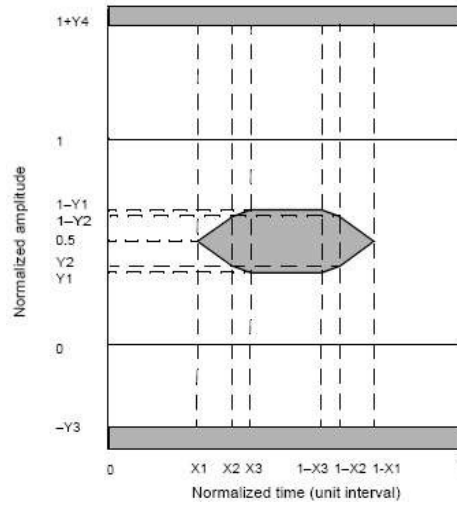

6. LOS Hysteresis

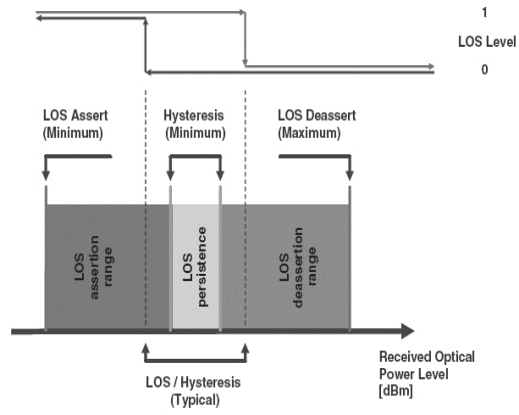

Pin Descriptions

Pin	Symbol	Channel No.	Function	Ref.
1	VeeT	Common	Transmitter Ground	Note 3
2	TX Fault	Common	Transmitter Fault Indication	Note 8
3	TX1_Disable	1	Transmitter Disable of Ch1	Note 1, module disables on high or open
4	MOD-DEF2	Common	Two-Wires Interface Data	Note 2, 2wire serial ID interface SDA
5	MOD-DEF1	Common	Two-Wires Interface Clock	Note 2, 2wire serial ID interface SCL
6	TD2-	2	Inverted Transmit Data Input of Ch2	Note 6
7	TD2+	2	Transmit Data Input of Ch2	Note 6
8	LOS1	1	Loss of Signal of CH1.	Note 7
9	RD2+	2	Received Data output of Ch2	Note 4
10	RD2-	2	Inverted Received Data output of Ch2	Note 4
11	VEE	Common	Transceiver Ground	Note 3
12	RD2-	1	Inverted received Data output of Ch1.	Note 4
13	RD2-	2	Received Data output of Ch1	Note 4
14	LOS2	2	Loss of Signal of CH2	Note 7
15	VCCR	Common	Receiver power	Note 5, 3.3V _T 5%
16	VCCT	Common	Transmitter Power	Note 5, 3.3V _T 5%
17	TX2_Disable	2	Transmitter Disable of Ch2	Note 1, Module disables on high or open
18	TD1+	1	Transmit Data Input of Ch1	Note 6
19	TD1-	1	Inverted Transmit Data Input of Ch1	Note 6
20	VEE	Common	Transceiver Ground	Note 6

Notes:

- TX_Disable1,2 are an input that us used to shut down the transmitter optical output. It is pulled up within the module with a 4.7K-10K_resistor. It's states are:
 - Low (0-0.8V): Transmitter on
 - (>0.8, <2.0V): Undefined
 - High (2.0-3.465V): Transmitter Disabled
 - Open: Transmitter Disabled
- Mod-Def 1,2. These are the module definition pins. They should be pulled up with a 4.7K-10K_resistor on the host board. The pull-up voltage shall be VccT or VccR.
Mod-Def 1 is the clock line of two wire serial interfaces for serial ID. Mod-Def 2 is the data line of two wire serial interface for serial ID.
- VEE may be internally connected within the SFO module.
- RD1, 2-/+: These are the differential receiver outputs. They are AC couples 100_ differential lines which should be terminated with 100_(differential) at the user SERDES. The AC coupling is done inside the

module and is this not required on the host board.

5. VccT, VccR are the power supplies. They are defined as 3.3V ±5% at the SFP connector pin. Maximum supply current is 600mA@3.3V. Vcc may be internally connected within the SFP transceiver module.
6. TD1, 2-/+: These are the differential transmitter inputs. They are AC coupled, differential lines with 100_ohm differential termination inside the module. The AC coupling is done inside the module and is thus not required on the host board.
7. LOS 1,2 (Loss of Signal) is an open collector/drain output, which should be pulled up with a 4.7K– 10KΩ resistor. Pull up voltage between 2.0V and Vcct, R+0.3V. When high, this output indicates the received optical power is below the worst-case receiver sensitivity (as defined by the standard in use). Low indicates normal operation. In the low state, the output will be pulled to <0.4V.
8. TX Fault report transceiver status as following:
 TX Fault is an open collector/drain output, which should be pulled up with a 4.7K–10K_ohm resistor on the host board. Pull up voltage between 2.0V and VccT, R+0.3V. When high, output indicated a laser fault of some kind either in Channel 1 or Channel 2. The Host shall read Channel1/2: A2H/AAH: 110 for details: TX Fault from channel 1 if bit 2 is set in [A2H:110]; TX Fault from channel 2 if bit 2 is set in [B2H: 110]. Low indicated normal operation. In the low state, the output will be pulled to < 0.8V.

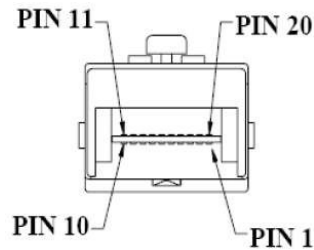
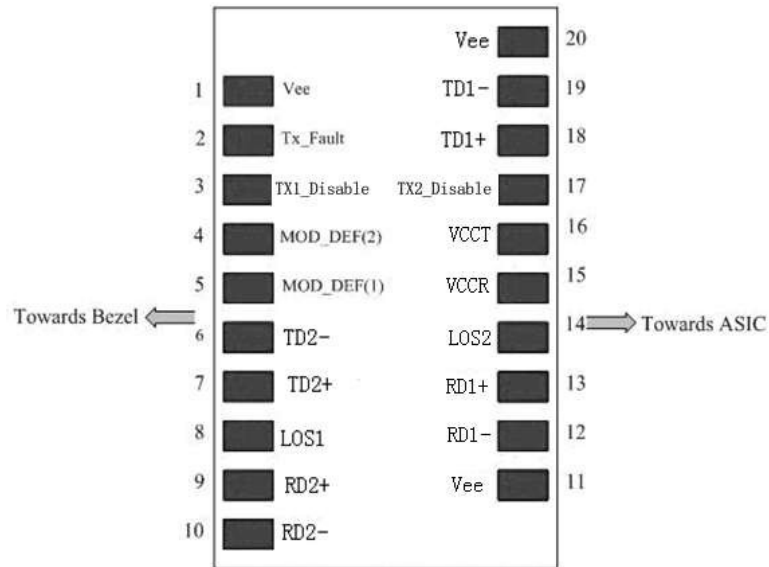

Recommended Circuit Schematic

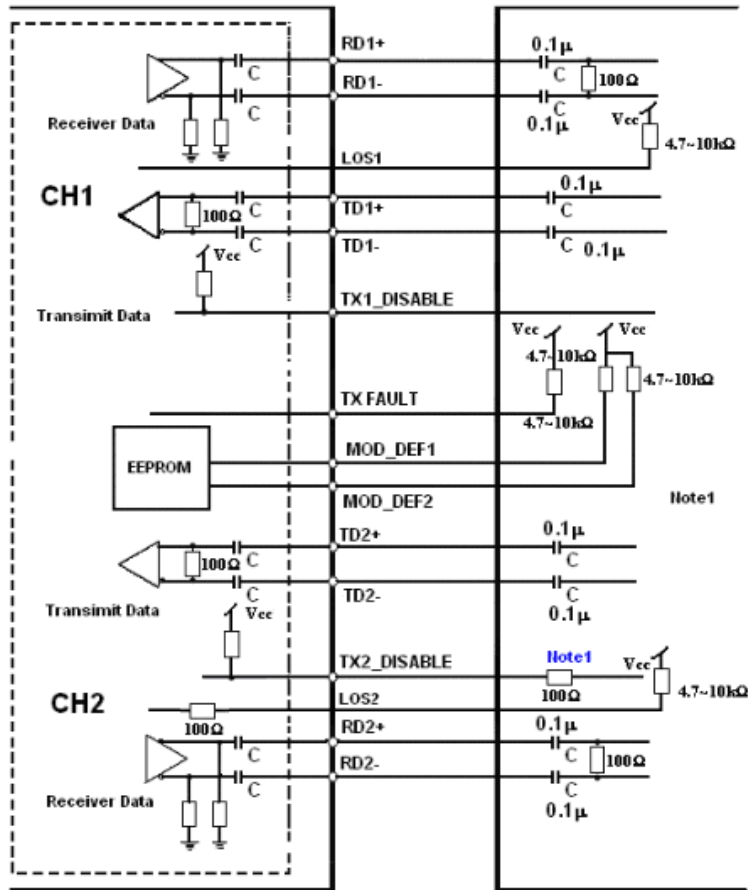

Laser Emission



Mechanical Specifications

Small Form Factor Pluggable (SFP) transceivers are compatible with the dimensions defined by the SFP Multi-Sourcing Agreement (MSA).

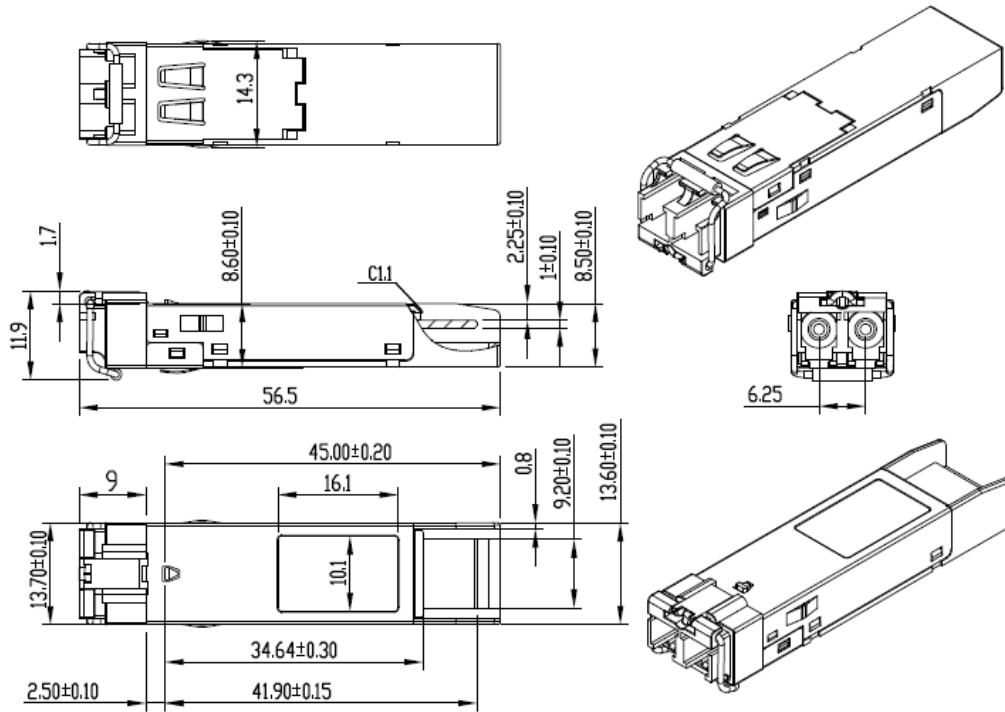

EEPROM Information

EEPROM memory map specific data field description is as below:

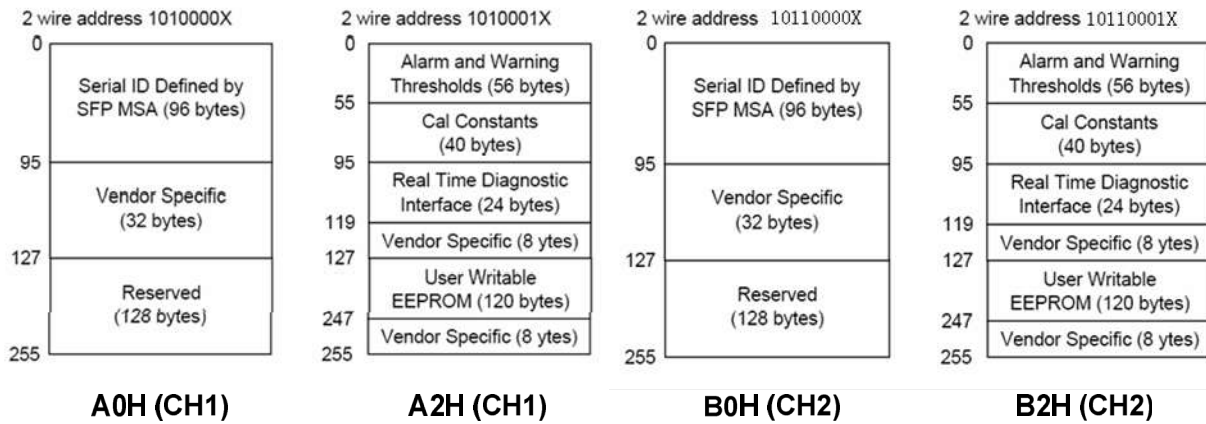

About AddOn Networks

In 1999, AddOn Networks entered the market with a single product. Our founders fulfilled a severe shortage for compatible, cost-effective optical transceivers that compete at the same performance levels as leading OEM manufacturers. Adhering to the idea of redefining service and product quality not previously had in the fiber optic networking industry, AddOn invested resources in solution design, production, fulfillment, and global support.

Combining one of the most extensive and stringent testing processes in the industry, an exceptional free tech support center, and a consistent roll-out of innovative technologies, AddOn has continually set industry standards of quality and reliability throughout its history.

Reliability is the cornerstone of any optical fiber network and is engrained in AddOn's DNA. It has played a key role in nurturing the long-term relationships developed over the years with customers. AddOn remains committed to exceeding industry standards with certifications from ranging from NEBS Level 3 to ISO 9001:2005 with every new development while maintaining the signature reliability of its products.

U.S. Headquarters

Email: sales@addonnetworks.com

Telephone: +1 877.292.1701

Fax: 949.266.9273

Europe Headquarters

Email: salesupportemea@addonnetworks.com

Telephone: +44 1285 842070