

THERMAL PRINTER

TSP1000 SERIES

USER'S MANUAL

MODE D'EMPLOI

BEDIENUNGSANLEITUNG

MANUALE DI ISTRUZIONI

stair 

**Federal Communications Commission
Radio Frequency Interference
Statement**

This equipment has been tested and found to comply with the limits for a Class A digital device, pursuant to Part 15 of the FCC Rules. These limits are designed to provide reasonable protection against harmful interference when the equipment is operated in a commercial environment. This equipment generates, uses and can radiate radio frequency energy and, if not installed and used in accordance with the instruction manual, may cause harmful interference to radio communications. Operation of this equipment in a residential area is likely to cause harmful interference in which case the user will be required to correct the interference at his own expense.

For compliance with the Federal Noise Interference Standard, this equipment requires a shielded cable.

This statement will be applied only for the printers marketed in U.S.A.

**Statement of
The Canadian Department of Communications
Radio Interference Regulations**

This digital apparatus does not exceed the Class A limits for radio noise emissions from digital apparatus set out in the Radio Interference Regulations of the Canadian Department of Communications.

Le présent appareil numérique n'émet pas de bruits radioélectriques dépassant les limites applicables aux appareils numériques de la classe A prescrites dans le Règlement sur le brouillage radioélectrique édicté par le ministère des Communications du Canada.

The above statement applies only to printers marketed in Canada.

**CE
Manufacturer's Declaration of Conformity**

EC Council Directive 89/336/EEC of 3 May 1989

This product, has been designed and manufactured in accordance with the International Standards EN 61000-6-3 / 2001 and EN 55024 / 1998, following the provisions of the Electro Magnetic Compatibility Directive of the European Communities as of May 1989.

EC Council Directive 73/23/EEC and 93/68/EEC of 22 July 1993

This product, has been designed and manufactured in accordance with the International Standards EN 60950-1, following the provisions of the Low Voltage Directive of the European Communities as of 2001.

The above statement applies only to printers marketed in EU.

Trademark acknowledgments

TSP1000: Star Micronics Co., Ltd.

ESC/POS: Seiko Epson Corporation

Notice

- All rights reserved. Reproduction of any part of this manual in any form whatsoever, without STAR's express permission is forbidden.
- The contents of this manual are subject to change without notice.
- All efforts have been made to ensure the accuracy of the contents of this manual at the time of going to press. However, should any errors be detected, STAR would greatly appreciate being informed of them.
- The above notwithstanding, STAR can assume no responsibility for any errors in this manual.

TABLE OF CONTENTS

| | |
|---|------------|
| 1. Unpacking and Installation | 1 |
| 1-1. Unpacking | 1 |
| 2. Parts Identification and Nomenclature | 2 |
| 3. Consumable Parts and AC Adapter | 4 |
| 4. Connecting Cables and AC Adapter | 6 |
| 4-1. Interface Cable | 6 |
| 4-2. Connecting to a Buzzer Drive | 10 |
| 4-3. Connecting the Optional AC Adapter | 11 |
| 4-4. Turning Power On | 12 |
| 4-5. Installing the Cable | 13 |
| 4-6. Switch Blind Installation | 14 |
| 5. Control Panel and Other Functions | 15 |
| 5-1. Control Panel | 15 |
| 5-2. Errors | 15 |
| 5-3. Self Printing | 17 |
| 6. Loading the Roll Paper | 18 |
| 6-1. Loading the Roll Paper | 18 |
| 6-2. Paper Loading Methods | 21 |
| 6-3. Roll Paper Holder Adjustment | 22 |
| 6-4. Paper Guide Adjustment | 23 |
| 6-5. Upper Guide Adjustment | 24 |
| 7. Adjusting the Near-end Sensor | 25 |
| 8. Preventing and Clearing Paper Jams | 27 |
| 8-1. Preventing Paper Jams | 27 |
| 8-2. Removing Paper Jam | 27 |
| 8-3. Releasing a Locked Cutter | 28 |
| 9. Periodical Cleaning | 30 |
| 9-1. Cleaning the Thermal Head | 30 |
| 9-2. Cleaning the Paper Holder | 30 |
| Appendix A: Specifications | 128 |
| A-1. General Specifications | 128 |
| A-2. Auto Cutter Specifications | 129 |
| A-3. Interface | 129 |
| A-4. Electrical Characteristics | 129 |
| A-5. Option | 129 |
| A-6. Environmental Requirements | 130 |
| A-7. Reliability | 130 |
| A-8. Black Mark Specifications | 131 |
| Appendix B: Dip Switch Setting | 134 |
| B-1. Parallel Interface Model | 135 |
| B-2. Serial Interface (RS-232C) Model | 136 |
| B-3. USB Interface Model | 138 |
| B-4. Ethernet Interface Model | 139 |
| B-5. Wireless LAN Interface Model | 141 |
| Appendix C: Parallel Interface | 144 |
| Appendix D: Serial Interface (RS-232C) | 145 |
| D-1. RSConnector | 145 |
| D-2. Cable Connections | 147 |
| D-3. Electrical Characteristics | 147 |
| Appendix E: USB, Ethernet and Wireless LAN Interface | 148 |
| E-1. USB Interface Specifications | 148 |
| E-2. Ethernet Interface Specifications | 148 |
| E-3. Wireless LAN Interface Specifications | 148 |
| Appendix F: Buzzer Driver Circuit | 149 |
| Appendix G: Memory Switch Settings | 151 |

1. Unpacking and Installation

1-1. Unpacking

After unpacking the unit, check that all the necessary accessories are included in the package.

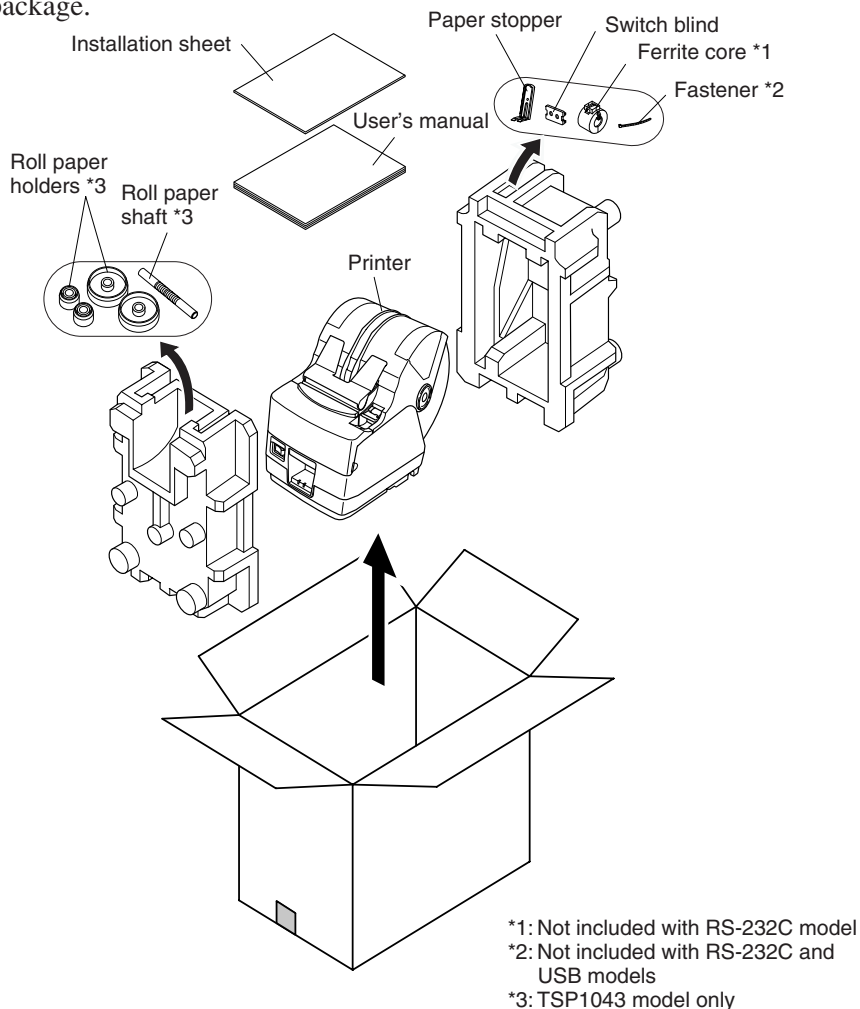
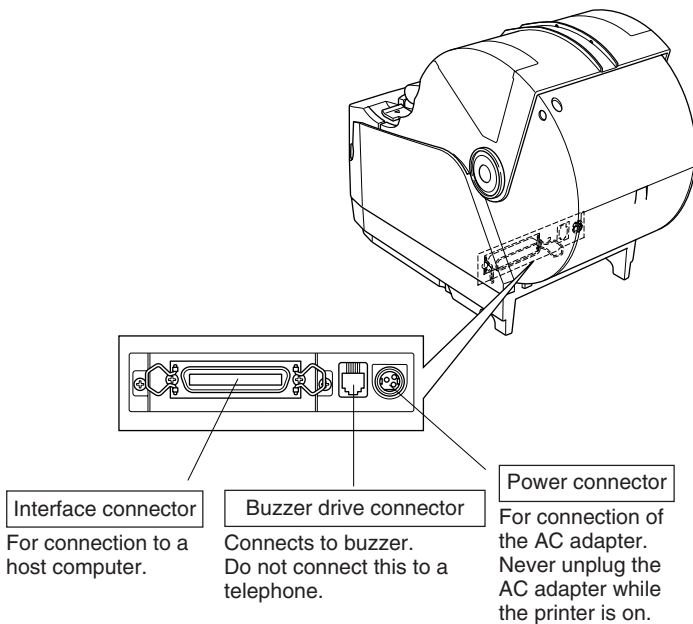
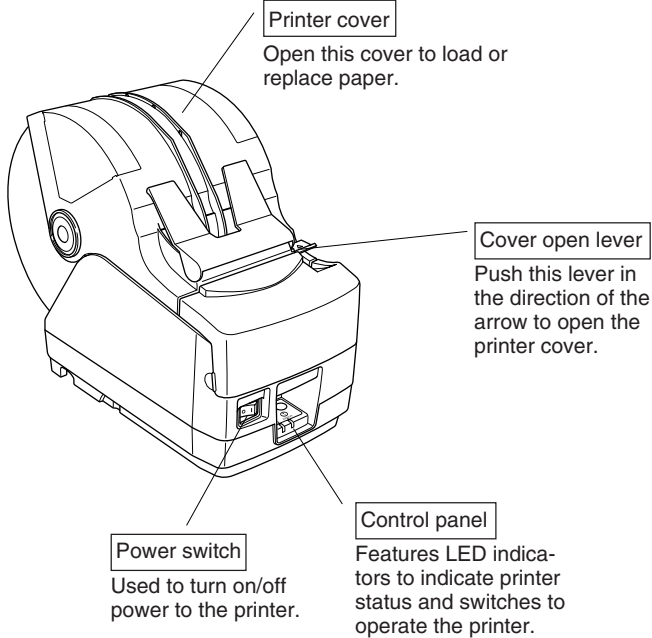

Fig. 1-1 Unpacking

If anything is missing, contact the dealer where you bought the printer and ask them to supply the missing part. Note that it is a good idea to keep the original box and all the packing materials just in case you need to pack the printer up again and send it somewhere at a later date.

2. Parts Identification and Nomenclature



Choosing a place for the printer

Before actually unpacking the printer, you should take a few minutes to think about where you plan to use it. Remember the following points when doing this.

- ✓ Choose a firm, level surface where the printer will not be exposed to vibration.
- ✓ The power outlet you plan to connect to for power should be nearby and unobstructed.
- ✓ Make sure that the printer is close enough to your host computer for you to connect the two.
- ✓ Make sure that the printer is not exposed to direct sunlight.
- ✓ Make sure that the printer is well away from heaters and other sources of extreme heat.
- ✓ Make sure that the surrounding area is clean, dry, and free of dust.
- ✓ Make sure that the printer is connected to a reliable power outlet. It should not be on the same electric circuit as copiers, refrigerators, or other appliances that cause power spikes.
- ✓ Make sure that the room where you are using the printer is not too humid.

WARNING

- ✓ Shut down your equipment immediately if it produces smoke, a strange odor, or unusual noise. Immediately unplug the equipment and contact your dealer for advice.
- ✓ Never attempt to repair this product yourself. Improper repair work can be dangerous.
- ✓ Never disassemble or modify this product. Tampering with this product may result in injury, fire, or electric shock.

3. Consumable Parts and AC Adapter

When consumable parts have run out, use those specified in the table below. Make sure that the AC adapter specified in the table is used.

Use of consumable parts or an AC adapter which are not specified in the table may result in damage to the printer, fire or electric shock.

(1) Roll paper specifications

Thermal paper

Thickness: 65 to 150 μm

Width: 44.5 \pm 0.5 to 82.5 \pm 0.5 mm

Outer roll diameter: Max. ϕ 180 mm

(When using drop-in paper loading)

Max. ϕ 170 mm

(When using roll paper shaft)

Take up paper roll width: 45 $^{+0.5}_{-1}$ to 83 $^{+0.5}_{-1}$ mm

Core outer/inner diameter

| Paper thickness | Core outer | Core inner |
|-------------------------|---------------------------|-----------------------------|
| 65 – 100 μm | Max. ϕ 40 \pm 1 mm | Max. ϕ 25.4 \pm 1 mm |
| 100 – 150 μm | Max. ϕ 58 \pm 1 mm | Max. ϕ 50.8 \pm 1 mm |

Printed surface: Outer surface of roll

Tail end handling: Do not use paste or glue to secure the roll paper or its core.

Do not fold the tail end of the paper.

(2) Recommended paper

Mitsubishi Paper Mills Limited

T8037 (tickets), 85 μm (thickness)

TF8067 (tickets), 84 μm (thickness)

TF8075 (tickets), 85 μm (thickness)

KANZAN

KLS46 (tickets)

KPO460 (tickets)

Kanzaki Specialty Papers Inc. (KSP)

Lotto482 (tickets), 84 μm (thickness)

Depending on the type and thickness of the paper, it may be necessary to change the settings for printing darkness. To change the darkness settings, use the printing darkness settings command <ESC><RS> 'd' n or the memory switch settings. Refer to the separate Specification Manual for details.

(3) AC adapter (option)

Model name: PS60

Input: 100 to 240 V AC, 50/60 Hz

Output: DC24±5%, 2.0 A (5.0 A Load 10 sec. Max.)

⚠ CAUTION

Access the following URL for the information of the recommended paper.
<http://www.star-m.jp/eng/dl/dl02.htm>

4. Connecting Cables and AC Adapter

4-1. Interface Cable

Note that the interface cable is not provided. Please use a cable that meets specifications.

⚠ CAUTION

Before connecting/disconnecting the interface cable, make sure that power to the printer and all the devices connected to the printer is turned off. Also make sure the power cable plug is disconnected from the AC outlet.

4-1-1. Serial Interface (RS-232C) Cable

- (1) Make sure the printer is turn off.
- (2) Connect the interface cable to the connector on the rear panel of the printer.
- (3) Tighten the connector screws.

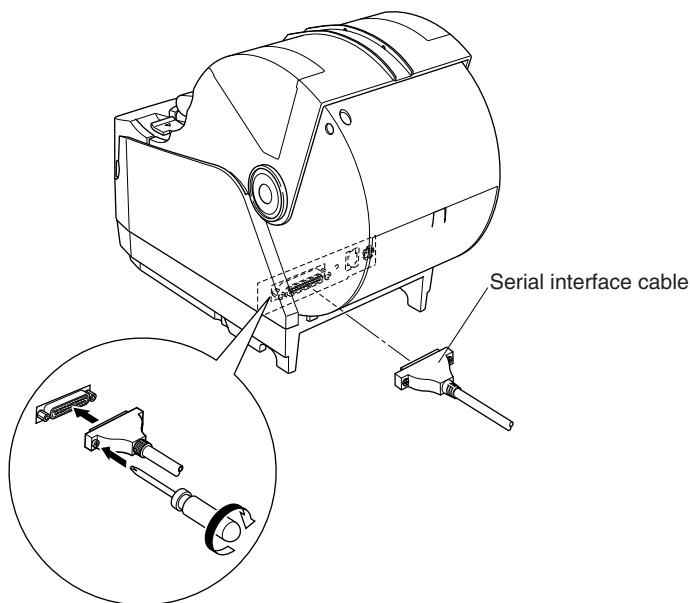

4-1-2. Parallel Interface Cable

- (1) Make sure the printer is turn off.
- (2) For only the parallel interface model, affix the ferrite core onto the cable as shown in the illustration below.

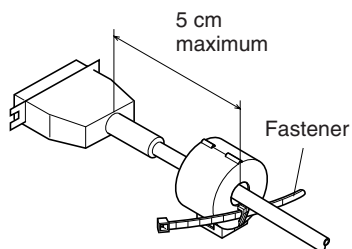
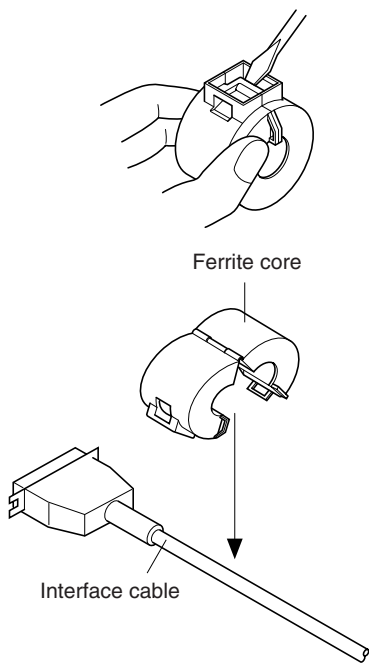

- (3) Pass the fastener through the ferrite core.

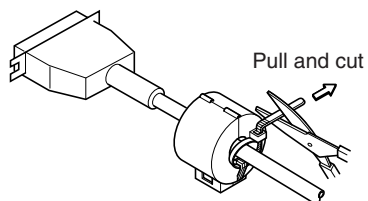

- (4) Loop the fastener around the cable and lock it. Use scissors to cut off any excess.

- (5) Connect the interface cable to the connector on the rear panel of the printer.
- (6) Fasten the connector clasps.

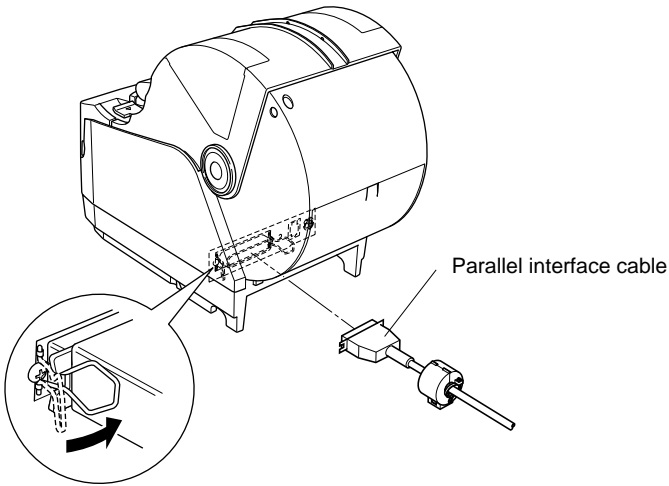

4-1-3. Connecting USB Cable

- (1) Make sure the printer is turn off.
- (2) Affix the ferrite core onto the USB cable as shown in the illustration below and make sure to pass the cable through the cable support as shown in the illustration.

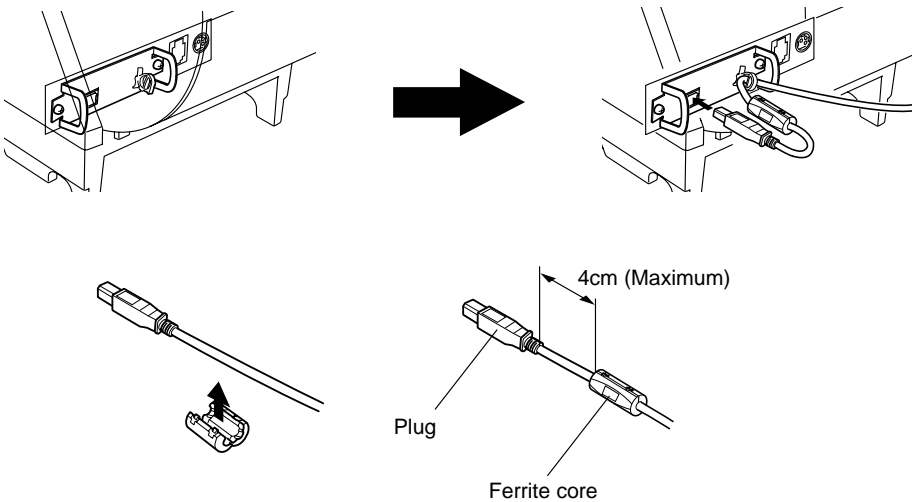

4-1-4. Connecting Ethernet Cable

(1) Make sure the printer is turned off.

(2) Affix the ferrite core onto the ethernet cable as shown in the illustration below.

(3) Pass the fastener through the ferrite core.

(4) Loop the fastener around the cable and lock it. Use scissors to cut off any excess.

(5) Connect the ethernet cable to the connector on the interface board. Then, connect the other end of the cable to your computer.

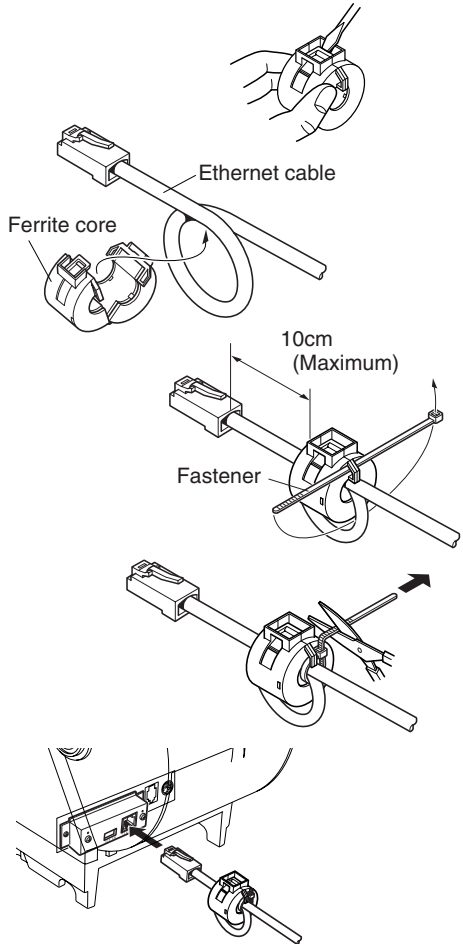

4-2. Connecting to a Buzzer Drive

You can connect a buzzer drive to the printer using a modular plug. The following describes how to make the actual connection. See “Modular plug” on page 149 for details about the type of modular plug that is required. Note that this printer does not come with a modular plug or wire, so it is up to you to obtain one that suits your needs.

⚠ CAUTION

Make sure that the printer is turned off and unplugged from the AC outlet and that the computer is turned off before making connections.

Connect the buzzer drive cable to the connector on the rear panel of the printer.

⚠ CAUTION

Do not connect a telephone line into the buzzer drive connector. Failure to observe this may result in damage to the printer.
Also, for safety, do not connect wiring to the buzzer drive connector if there is a chance it may carry excess voltage.

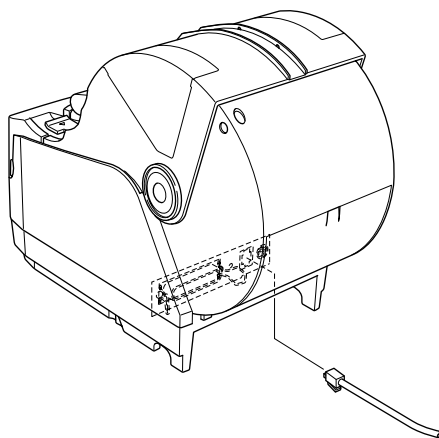

4-3. Connecting the Optional AC Adapter

Note: Before connecting/disconnecting the AC adapter, make sure that power to the printer and all the devices connected to the printer is turned off. Also make sure the power cable plug is disconnected from the AC outlet.

(1) Connect the AC adapter to the power cable.

Note: Use only the standard AC adapter and power cable.

(2) Connect AC adapter to the connector on the printer.

(3) Insert the power cable plug into an AC outlet.

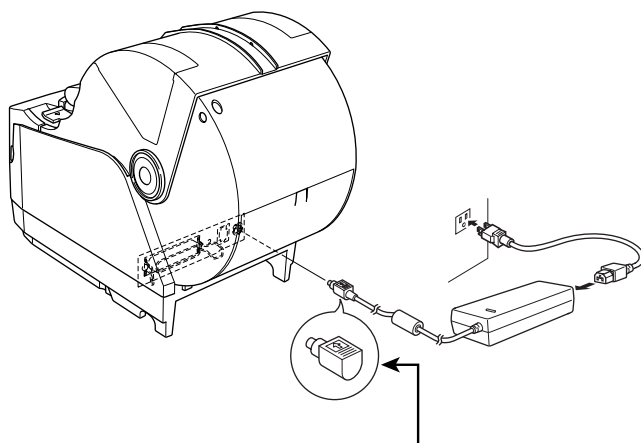

⚠ CAUTION

When disconnecting the cable, take hold of the cable connector to pull it out. Releasing the lock makes it easy to disconnect the connector.

Pulling the cable excessively could cause damage to the connector.

4-4. Turning Power On

Make sure that the AC adapter has been connected as described in 4-3.

- (1) Set the power switch located on the front of the printer to on.
The POWER lamp on the control panel will light up.

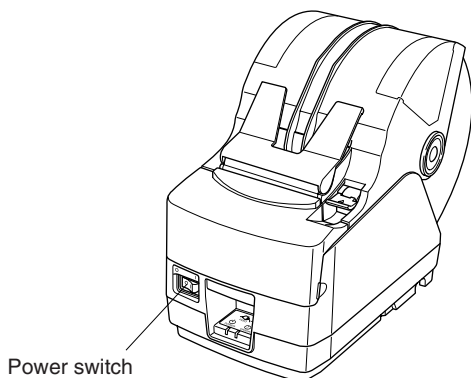

⚠ CAUTION

We recommend that you unplug the printer from the power outlet whenever you do not plan to use it for long periods. Because of this, you should locate the printer so that the power outlet it is plugged into is nearby and easy to access.

4-5. Installing the Cable

Install the cable as shown in the diagram below.

ENGLISH

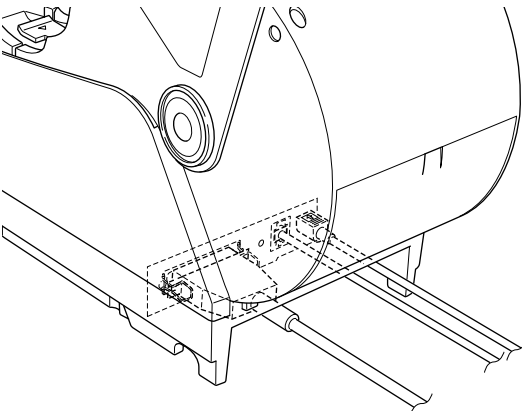
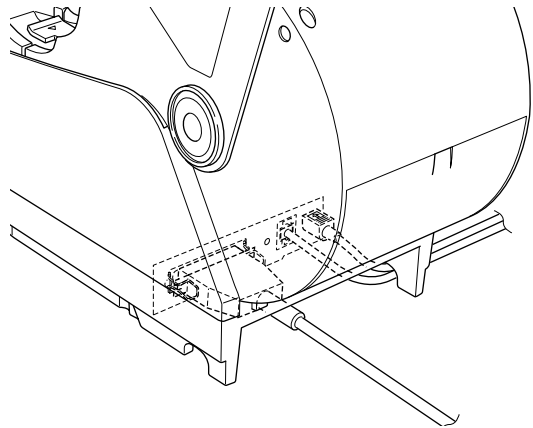
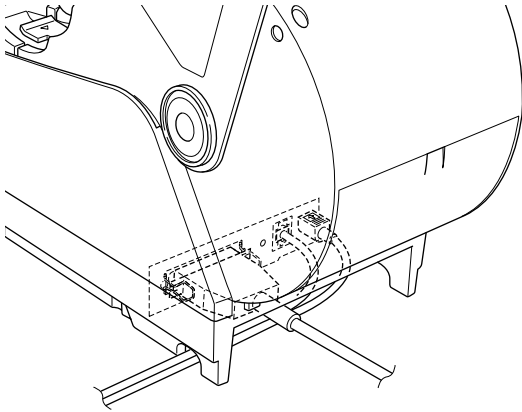

4-6. Switch Blind Installation

It is not necessary to install the switch blind. Only install it if it is necessary for you. By installing the switch blind, the following become possible.

- Preventing the power switch from being operated by mistake.
- Ensuring that other people can not easily operate the power switch.

Install the switch blind as shown in the diagram below.

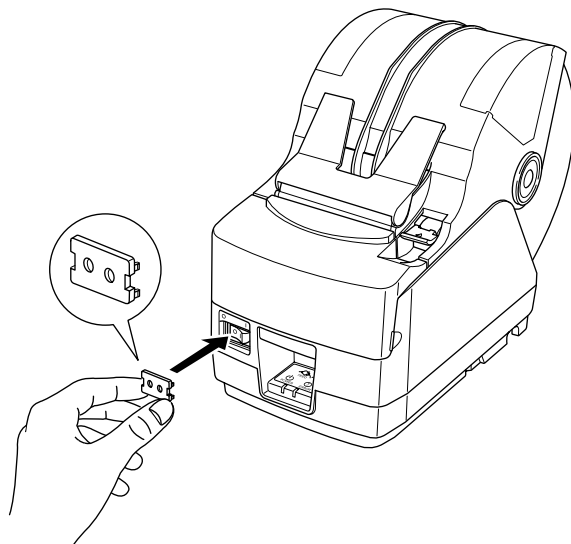

The power switch can be turned ON (I) and OFF (O) by inserting a narrow instrument (ball pen etc.) in the holes in the switch blind.

⚠ CAUTION

We recommend that you unplug the printer from the power outlet whenever you do not plan to use it for long periods. Because of this, you should locate the printer so that the power outlet it is plugged into is nearby and easy to access.

5. Control Panel and Other Functions

5-1. Control Panel

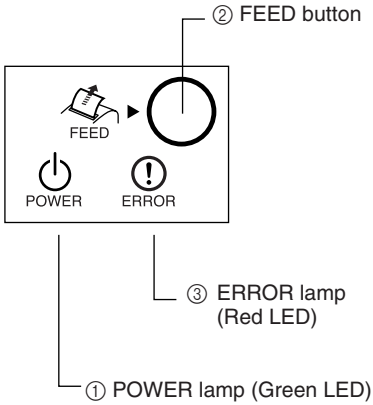

- ① POWER lamp (Green LED)
Lights when the power is ON
- ② FEED button
Press the FEED button to feed roll paper.
- ③ ERROR lamp (Red LED)
Indicates various errors in combination with POWER lamp

5-2. Errors

(1) Automatically recoverable error

| Error Description | POWER lamp | ERROR lamp | Recovery Conditions |
|---------------------------------|---------------------------------|------------|--|
| Head high temperature detection | Flashes at 0.5 second intervals | Off | Automatically recovered after the print head has cooled. |
| Cover open error | On | On | Automatically recovered by closing the printer cover. |

(2) Recoverable error

| Error Description | POWER lamp | ERROR lamp | Recovery Conditions |
|-------------------|------------|-----------------------------------|--|
| Paper cut error | Off | Flashes at 0.125 second intervals | Recovered If the cutter returns to the home position after turning the power OFF and ON. |

Note:

- 1) If the cutter doesn't return to the home position, or doesn't perform the initial movement, it cannot be recovered.
- 2) If the paper is jammed, turn the power off, clear the jammed paper, then turn the power ON.

(3) Non recoverable error

| Error Description | POWER lamp | ERROR lamp | Recovery Conditions |
|--------------------|------------|----------------------------------|--|
| RAM error | Off | Flashes at 1.0 second intervals | This is not a recoverable error. Consult dealer for repairs. |
| EERROM error | Off | Flashes at 0.75 second intervals | This is not a recoverable error. Consult dealer for repairs. |
| Flash ROM error | Off | Flashes at 0.5 second intervals | This is not a recoverable error. Consult dealer for repairs. |
| Thermistor error | Off | Flashes at 1.5 second intervals | This is not a recoverable error. Consult dealer for repairs. |
| Power supply error | Off | Flashes at 2 second intervals | This is not a recoverable error. Consult dealer for repairs. |

Note:

- 1) If a non recoverable error occurs, turn the power OFF immediately.
- 2) When Power supply error occurs, there is a possibility that the power supply unit has a trouble.

For other non recoverable errors, please consult the dealer for repairs.

(4) Paper detection error

| Error Description | POWER lamp | ERROR lamp | Recovery Conditions |
|-------------------|------------|---------------------------------|--|
| Paper out error | On | Flashes at 0.5 second intervals | Automatically recovered by loading a new paper roll, then closing the printer cover. |
| Paper near end | On | Flashes at 2 second intervals | Indicators show that the paper end is approaching, but the printer continues to print. |

5-3. Self Printing

(1) Test Printing

Turn the power on while holding the FEED button depressed.

Test printing will be performed according to the Ver. No., DIP switch settings and memory switch settings.

```
*** TSP1000 Ver1.00
```

```
Interface : Parallel
```

```
DIP Switch 1
Sw 12345678
On *******
Off
```

(2) Hexadecimal Dump Mode

Open the printer cover, then turn the power on while holding the FEED button. When the cover is closed, “*** HEX DUMP PRINTING ***” is printed, and the printer enters the Hexadecimal Dump Mode.

Each of the signals sent from the computer to the printer will be printed out in hexadecimal code.

This function allows you to check if a control code sent to the printer by the program being used is correct or not. The final line is not printed if its data is less than one full line. However, if the FEED button is pushed, the final line is printed. To turn off the mode, it is necessary to turn off the printer completely.

```
*** HEX DUMP PRINTING ***
```

| | |
|-------------------------|-------------|
| 20 21 22 23 24 25 26 27 | !''#\$\$%&' |
| 28 29 2A 2B 2C 2D 2E 2F | ()**,-./ |
| 30 31 32 33 34 35 36 37 | 01234567 |
| 38 39 3A 3B 3C 3D 3E 3F | 89:;<=>? |
| 40 41 42 43 44 45 46 47 | @ABCDEFGF |
| 48 49 4A 4B 4C 4D 4E 4F | HIJKLMNO |
| 50 51 52 53 54 55 56 57 | PQRSTUVWXYZ |

6. Loading the Roll Paper

6-1. Loading the Roll Paper

Loading the roll paper in this printer differs according to the type of paper (drop-in roll paper or roll paper that requires the shaft). Load the roll paper according to the procedures on the section 6-2.

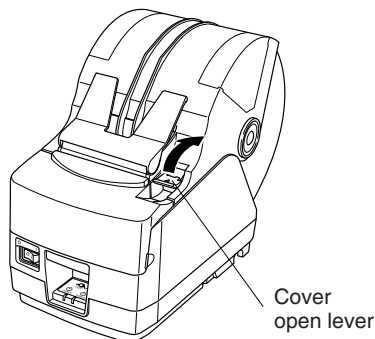

- (1) Push the Cover open lever, and open the printer cover.
- (2) While observing the direction of the roll, set the roll paper into the hollow, and pull the leading edge of the paper toward you.

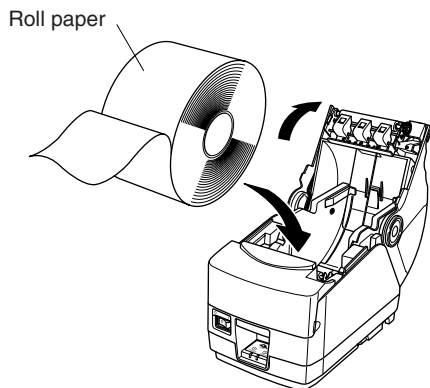
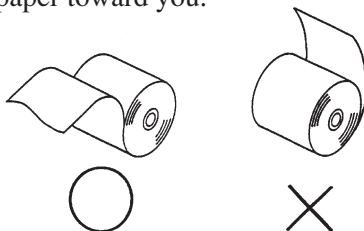

[Drop-in paper loading]

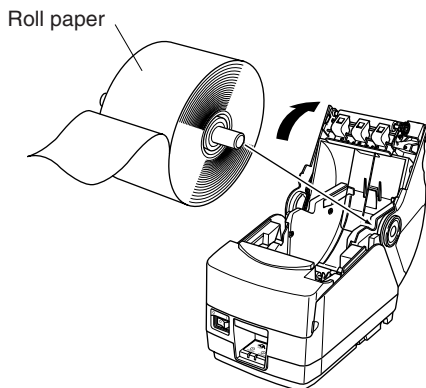

[Using shaft]

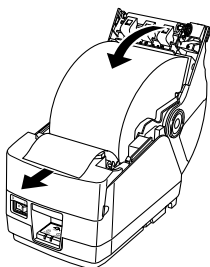

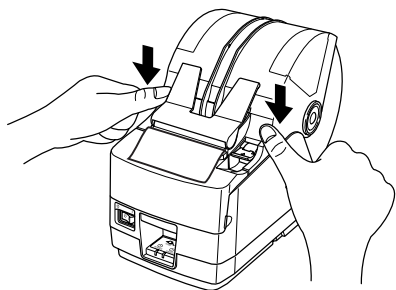

- (3) Pull on the edge of the paper to remove any slack and then push down both sides of the printer cover to close it.

Note: Make sure that the printer cover is securely closed.

- (4) If the printer cover is closed after turning on the power, the cutter operates automatically and the front end of the paper is cut.

Note: If the cutter does not operate after the printer cover is closed, open the cover and close it again securely.

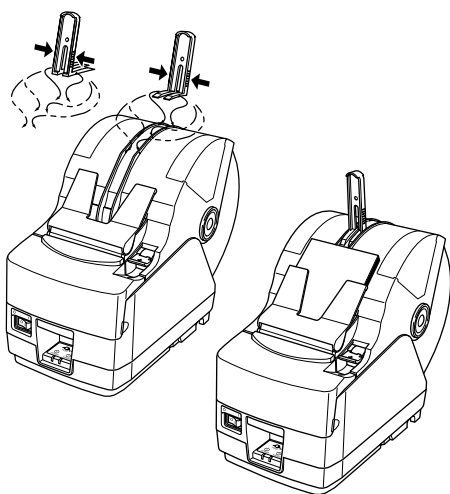

- (5) If necessary, attach the paper stopper to the paper cover as shown. The output tray can hold up to 30 sheets (width: 80-82.5 mm, thickness: 80–120 μm , length: 50–150 mm). For paper with a different thickness or for other sheet lengths, the limit is 10 sheets.

Note: When attaching the paper stopper to the paper cover, position the stopper according to the length of the cut paper. (Refer to the following table.)

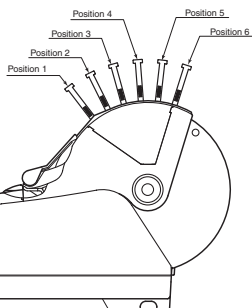

| | Paper length (mm) |
|------------|-------------------|
| Position 1 | 50 – 100 |
| Position 2 | 100 – 120 |
| Position 3 | 120 – 140 |
| Position 4 | 140 – 160 |
| Position 5 | 160 – 180 |
| Position 6 | 180 – 200 |

⚠ WARNING

- *Do not touch the cutter blade.*
 - *There is a cutter inside the paper outlet slot. Not only should you not put your hand in the paper outlet slot while printing is in progress, never put your hand into the outlet even when printing is not in progress.*
 - *The printer cover can be opened when replacing the paper. However, since the cutter blade is on the inside of the printer cover, be careful not to place your face or hands too close to the cutter blade.*
 - *During and immediately after printing, the area around the thermal head is very hot. Do not touch it, as you could be burned.*
-

⚠ CAUTION

- *Do not operate the cover open lever while pressing on the printer cover with your hand.*
 - *Do not pull out paper while the printer cover is closed.*
 - *The heating element and the driver IC of the thermal head are easily damaged. Do not touch them with metal objects, sandpaper, etc.*
 - *Printing quality may suffer if the thermal head heating element becomes soiled by being touched with your hands. Do not touch the thermal head heating element.*
 - *There is a risk of damage to the driver IC of the thermal head from static electricity. Never directly touch the IC.*
 - *The printing quality and working life of the thermal head cannot be guaranteed if any paper other than that recommended is used. In particular, paper containing [Na⁺, K⁺, Cl⁻] may drastically reduce the working life of the thermal head. Please exercise caution.*
 - *Do not operate the printer if there is moisture on the front surface of the head from condensation, etc.*
-

6-2. Paper Loading Methods

This printer has two paper loading methods: one when using the roll paper shaft, and one when not using the shaft. The roll paper shaft is not used for drop-in paper loading. Select the paper loading method from the following table according to the type of paper used.

| Paper thickness (μm) \backslash Paper width (mm) | $44.5 \leq \text{Width} < 79.5$ | $79.5 \leq \text{Width} \leq 82.5$ |
|---|---------------------------------|------------------------------------|
| | $65 \leq \text{Thickness} < 80$ | Use roll paper shaft (*1, *4) |
| $80 \leq \text{Thickness} \leq 120$ | Use roll paper shaft (*1, *4) | Use drop-in loading (*3) |
| $120 < \text{Thickness} \leq 150$ | Use roll paper shaft (*1) | Use roll paper shaft (*1) |

Note:

- *1: Maximum outer roll diameter: 150 mm
- *2: Maximum outer roll diameter: 170 mm
- *3: Maximum outer roll diameter: 180 mm
- *4: The print speed must be changed from the high speed (factory default setting) to the middle speed (140 mm/sec.). To change the print speed, use the print speed settings command <ESC><RS> Rn. Refer to the separate Specification Manual for details.

6-3. Roll Paper Holder Adjustment

There are two different sized roll paper holders: roll paper holders 1 for paper that has a one-inch inner core diameter, and roll paper holders 2 for paper that has a two-inch inner core diameter. Select the roll paper holders according to the size of roll paper used.

- (1) Install the roll paper holders onto both ends of the roll paper shaft.
- (2) Adjust the positions of the roll paper holders according to the width of the roll paper used.
- (3) Insert the roll paper holders and shaft into the roll paper.

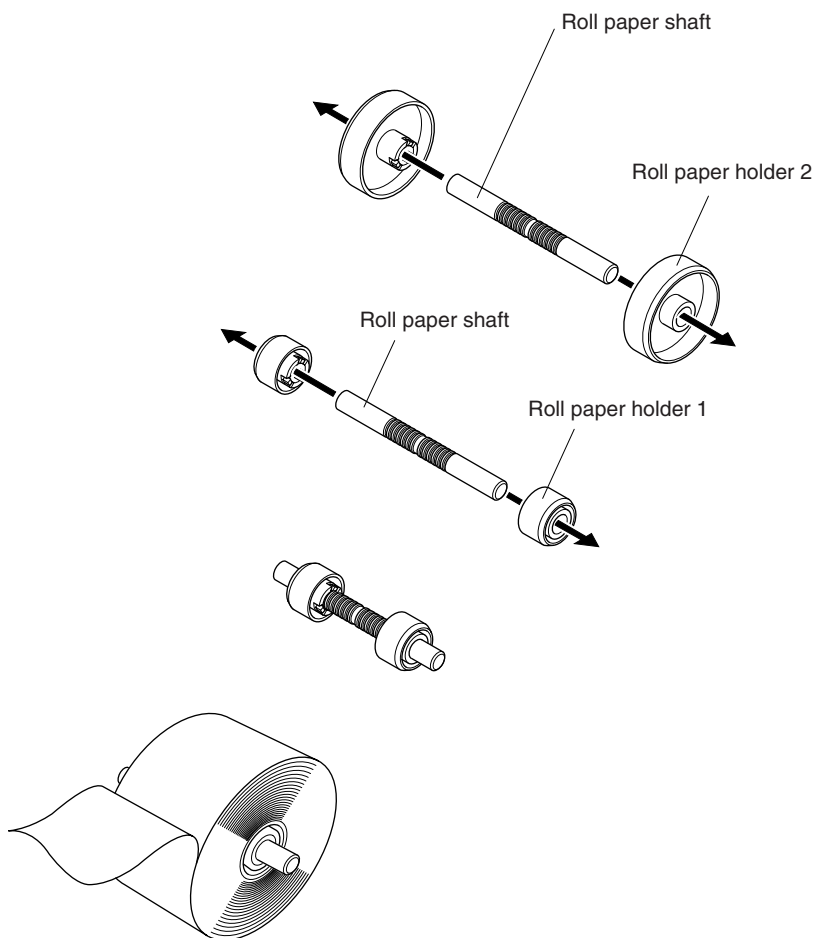

6-4. Paper Guide Adjustment

When the printer is shipped from the factory, the paper guides and upper guides are adjusted for roll paper with the following width.

Paper width: 79.5 ± 0.5 mm (TSP1043)

Paper width: 82.5 ± 0.5 mm (TSP1045)

When using roll paper with a width other than listed above, perform the following procedure to adjust the paper guides. To adjust the upper guides, refer to “6-5 Upper Guide Adjustment”.

- (1) Loosen the four screws.
- (2) Adjust the left and right paper guides according to the width of the roll paper, making sure to leave approximately 0.5 mm of space between each guide and the edge of the paper.

The scales on the metal plate inside the printer are divided into 1 mm segments between the \blacklozenge marks. The two \blacktriangledown marks above the scales are used for 57.5 mm wide paper and the two \blacklozenge marks are used for 79.5 mm wide paper. Accordingly, for roll paper with a width of 79.5 mm, position each paper guide 0.5 mm to the outside of the respective \blacklozenge mark. If necessary, screws 2 and 3 can be removed and installed in the adjacent screw holes.

- (3) Tighten the four screws.

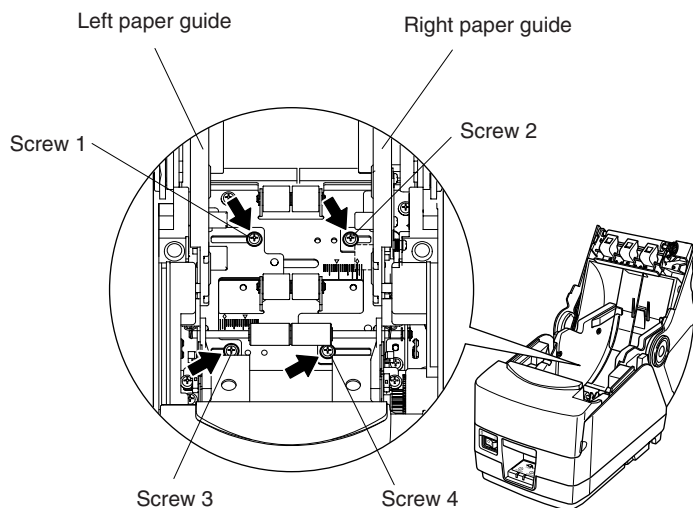

6-5. Upper Guide Adjustment

When the printer is shipped from the factory, the upper guides are adjusted for roll paper with a 79.5–82.5 mm width. When using roll paper with a different width, perform the following procedure to adjust the upper guides.

- (1) Loosen the two screws for the left and right upper guides.
- (2) Adjust the left and right upper guides according to the width of the roll paper, making sure that each guide is approximately 2 mm to the inside of the edge of the paper.

The scales on the metal plate on the cover are divided into 1 mm segments. The two ▲ marks below the scales are used for 57.5 mm wide paper and the two ◆ marks are used for 79.5 mm wide paper (also used for 82.5 mm wide paper). If necessary, the screws for the left and right upper guides can be removed and installed in the adjacent screw holes. If the roll paper width is 50 mm or less, remove the center upper guide by removing its screw, and then adjust the left and right upper guides.

Note:

When adjusting the upper guides, be careful not to pinch or apply unnecessary force to the wires.

- (3) Tighten the two screws.

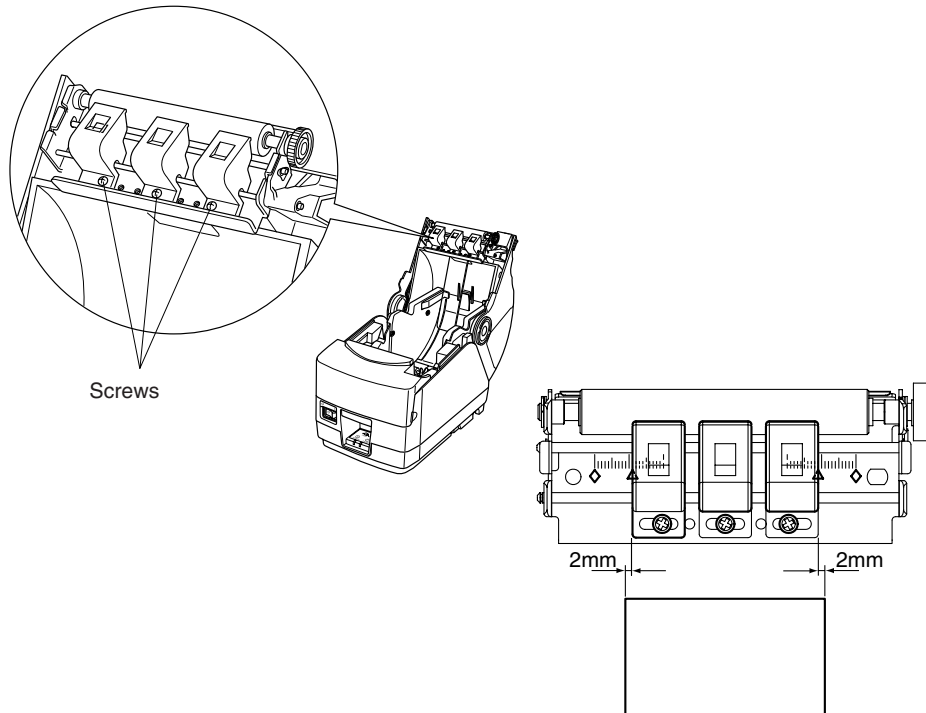

7. Adjusting the Near-end Sensor

Use the following procedure to adjust the near-end sensor so it is compatible with the size of roll paper you are using.

- ① Open the printer cover.
- ② Determine the correct position of the adjuster from the following three positions according to the paper loading method and the inner core diameter of the roll paper.
 Position 1: Using drop-in paper loading
 Position 2: Using roll paper holder 2 (ø50.8 mm inner core)
 Position 3: Using roll paper holder 1 (ø25.4 mm inner core)
- ③ Insert the tip of a ballpoint pen or similar object into the hole of the adjuster, and then push and slide the adjuster to the desired position.

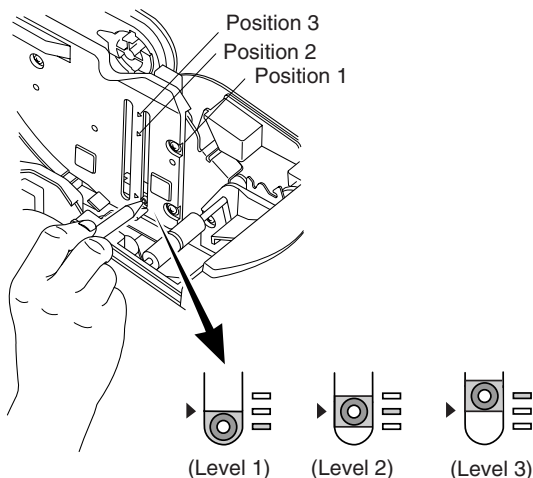

The amounts of remaining paper that can be detected are shown in the following table.

(1) Position 1

| Paper thickness (μm) | When using roll paper with an inside core diameter (A): ø25.4 and outside core diameter (B): ø40 | | | | | |
|----------------------|--|---------|---------|---------------------------------------|---------|---------|
| | Detected diameter (C) (Approx. mm) | | | Remaining paper length (Approx. m) | | |
| | Level 1 | Level 2 | Level 3 | Level 1 | Level 2 | Level 3 |
| 80 | ø44 | ø48 | ø52 | 3.5 | 7.5 | 12.5 |
| 105 | | | | 1.5 | 4.5 | 7.5 |

(2) Position 2

| Paper thickness (μm) | When using roll paper with an inside core diameter (A): $\phi 25.4$ and outside core diameter (B): $\phi 40$ | | | | | |
|-----------------------------------|--|-----------|---------|---------------------------------------|---------|---------|
| | Detected diameter (C) (Approx. mm) | | | Remaining paper length (Approx. m) | | |
| | Level 1 | Level 2 | Level 3 | Level 1 | Level 2 | Level 3 |
| 65 | — | $\phi 45$ | — | — | 5.6 | — |
| 80 | | | | | 4.4 | |
| 105 | | | | | 3.2 | |

(3) Position 3

| Paper thickness (μm) | When using roll paper with an inside core diameter (A): $\phi 50.8$ and outside core diameter (B): $\phi 58$ | | | | | |
|-----------------------------------|--|-----------|---------|---------------------------------------|---------|---------|
| | Detected diameter (C) (Approx. mm) | | | Remaining paper length (Approx. m) | | |
| | Level 1 | Level 2 | Level 3 | Level 1 | Level 2 | Level 3 |
| 150 | — | $\phi 69$ | — | — | 6.5 | — |

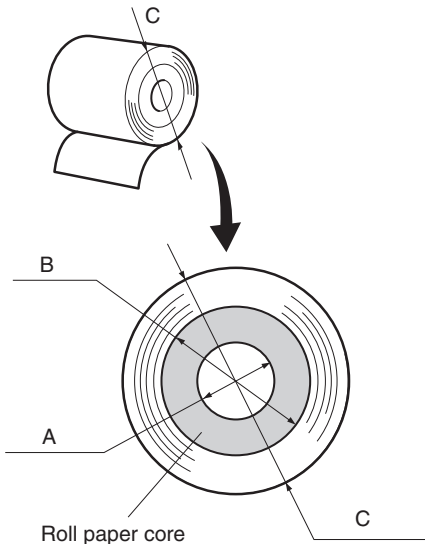

Note:

- 1) The adjuster is set to position 1, level 2 prior to being shipped from the factory.
- 2) The C dimension and the remained paper length are the calculated values. There may be some variations in actual mechanism.
- 3) The remaining paper lengths shown in the table above are for reference only. Adjust the near-end sensor to suit the actual conditions of use.
- 4) If thick paper is used (100 μm or greater paper thickness) when the adjuster is set to position 1, there will be looseness in the roll paper itself which makes it easier for detection variations to occur. Set to Level 3.

8. Preventing and Clearing Paper Jams

8-1. Preventing Paper Jams

The paper should not be touched during ejection and before it is cut. Pressing or pulling the paper during ejection may cause a paper jam, paper cutting failure or line feed failure.

8-2. Removing Paper Jam

If a paper jam occurs, clear it as described below.

(1) Set the power switch to off to turn off power to the printer.

(2) Push the cover open lever, and open the printer cover.

If the printer cover will not open on auto cutter models, it means that the auto cutter is not at the home position. In this case, return the auto cutter to the home position by following the instructions provided in section 8-3. Then open the printer cover after the paper jam has been removed.

(3) Remove the jammed paper.

⚠ CAUTION

Take care not to damage the printer when removing the jammed paper. Since it is easy to damage the thermal head in particular, take care not to touch it.

(4) Position the roll paper straight and close the printer cover gently.

Note:

- 1) Make sure that the paper is positioned straight. If the printer cover is closed with the paper skewed, a paper jam may result.
- 2) Lock the printer cover by pressing down both sides. Make sure that the printer cover is securely closed.

(5) Set the power switch to on to turn on power to the printer. Make sure that the ERROR LED is not lit.

Note: While the ERROR LED is lit, the printer will not accept any commands such as the print command, so make sure that the printer cover is locked properly.

8-3. Releasing a Locked Cutter

If the auto cutter locks up or fails to cut the paper, follow the steps below.

⚠ WARNING

Since working on the cutter may be dangerous, be sure to turn off the printer first.

- (1) Set the power switch to OFF to turn off the printer.
- (2) Slide off the front cover to reveal the auto cutter.
- (3) Remove any jammed paper.

⚠ CAUTION

Be careful not to damage the printer while removing any jammed paper. Since the thermal print head is particularly sensitive, be sure not to touch it.

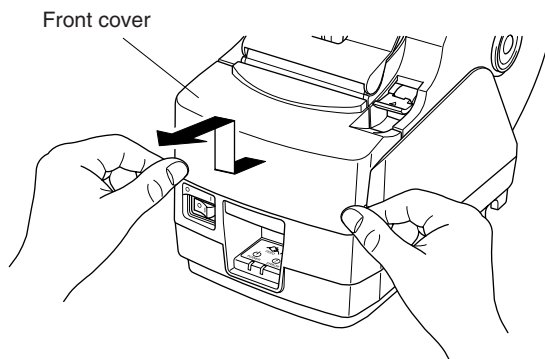

(4) If the cutter's moving blade is protruding, rotate the knob in the direction of an arrow to return the moving blade to its home position.

When the check window is completely white, the moving blade is at its home position.

⚠ CAUTION

1) Do not apply extreme pressure to the moving blade.

2) If the moving blade is protruding too much, the printer cover cannot be opened. Trying to open the printer cover may damage the cutter.

(5) Open the printer cover, remove any jammed paper, and then re-install the paper roll.

(6) Install the front cover, and then set the power switch to ON.

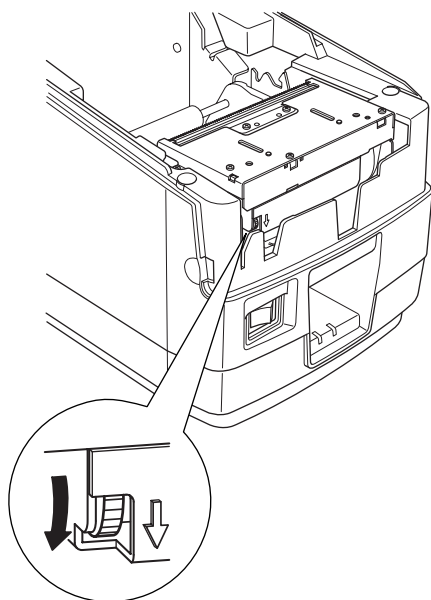

9. Periodical Cleaning

Printed characters may become partially unclear due to accumulated paper dust and dirt. To prevent such a problem, paper dust collected in the paper holder and paper transport section and on the surface of the thermal head must be removed periodically. Such cleaning is recommended to be carried out once six month or one million lines.

9-1. Cleaning the Thermal Head

To remove blackish dust collected on the surface of the thermal head, wipe it with Isopropyl alcohol (IPA).

Note: The thermal head is easy to damage, so clean it gently with a soft cloth. Take sufficient care not to scratch it when cleaning it.

9-2. Cleaning the Paper Holder

Use a soft cloth to remove paper dust from the paper holder and paper transport section.

TABLE DES MATIERES

| | |
|---|------------|
| 1. Déballage et inspection | 33 |
| 1-1. Déballage | 33 |
| 2. Identification des pièces et nomenclature | 34 |
| 3. Consommables et adaptateur secteur | 36 |
| 4. Câbles de connexion et adaptateur secteur | 38 |
| 4-1. Câble d'interface | 38 |
| 4-2. Raccordement d'une sonnerie | 42 |
| 4-3. Connexion de l'adaptateur secteur optionnel | 43 |
| 4-4. Mise sous tension de l'imprimante | 44 |
| 4-5. Installation du câble | 45 |
| 4-6. Installation du cache de l'interrupteur | 46 |
| 5. Panneau de commande et autres fonctions | 47 |
| 5-1. Panneau de commande | 47 |
| 5-2. Erreurs | 47 |
| 5-3. Auto-impression | 49 |
| 6. Chargement du rouleau de papier | 50 |
| 6-1. Chargement du rouleau de papier | 50 |
| 6-2. Méthodes de chargement du papier | 53 |
| 6-3. Réglage du support de rouleau de papier | 54 |
| 6-4. Réglage des guides papier | 55 |
| 6-5. Réglage des guides supérieurs | 56 |
| 7. Réglage du capteur de fin de rouleau | 57 |
| 8. Prévention et correction de bourrages de papier | 59 |
| 8-1. Prévention des bourrages de papier | 59 |
| 8-2. Correction de bourrages de papier | 59 |
| 8-3. Libération d'une unité de découpage bloquée | 60 |
| 9. Nettoyage | 62 |
| 9-1. Nettoyage de la tête d'impression | 62 |
| 9-2. Nettoyage du support de papier | 62 |
| APPENDICE | 128 |

L'appendice n'est pas traduit.

Pour obtenir la dernière version de ce manuel, consultez l'adresse URL suivante:

<http://www.star-m.jp/eng/dl/dl02.htm>

1. Déballage et inspection

1-1. Déballage

Après avoir déballé l'appareil, vérifiez si tous les accessoires nécessaires se trouvent dans la boîte.

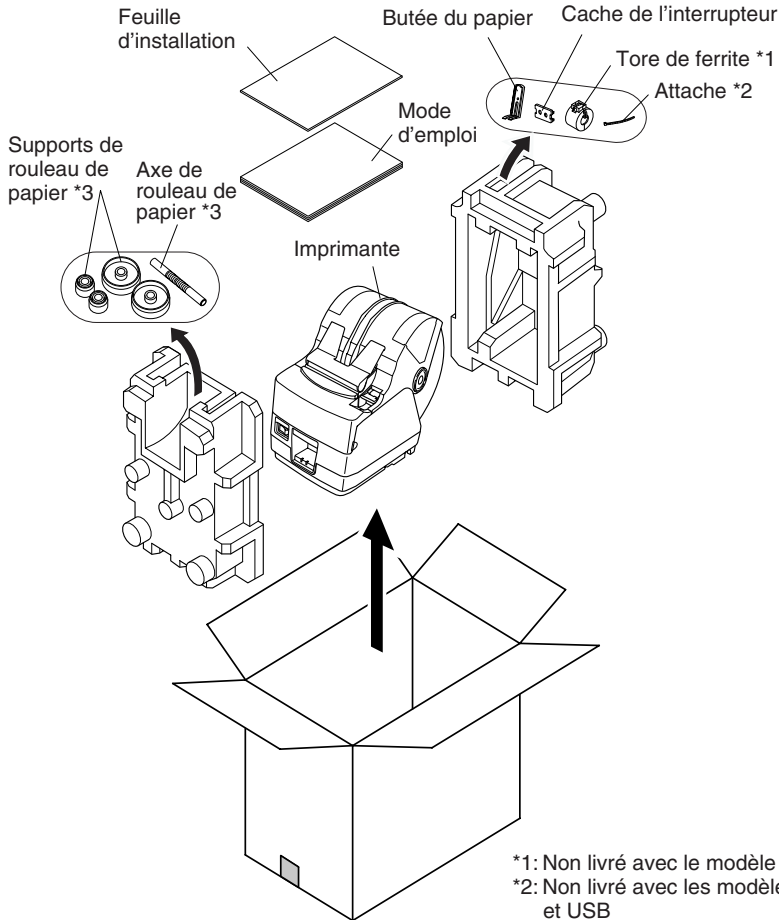

- *1: Non livré avec le modèle RS-232C
- *2: Non livré avec les modèles RS-232C et USB
- *3: Uniquement sur le modèle TSP1043

Fig. 1-1 Déballage

Si l'un des éléments mentionnés ci-dessus ne se trouve pas dans la caisse, adressez-vous au magasin où vous avez acheté l'imprimante et demandez que la pièce manquante vous soit fournie. Il est préférable de conserver la caisse d'origine ainsi que tous les emballages. Ceux-ci vous seront utiles s'il vous faut emballer l'imprimante ou la transporter.

2. Identification des pièces et nomenclature

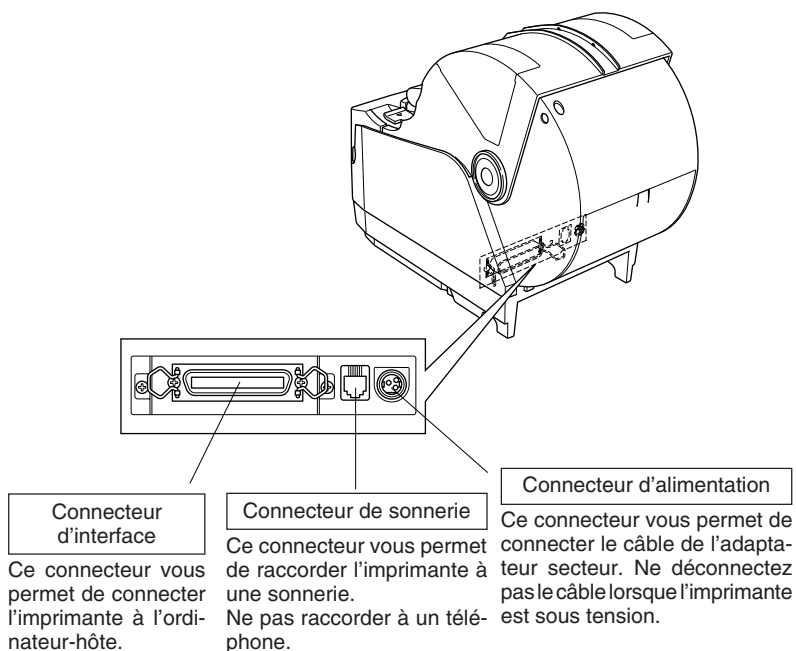
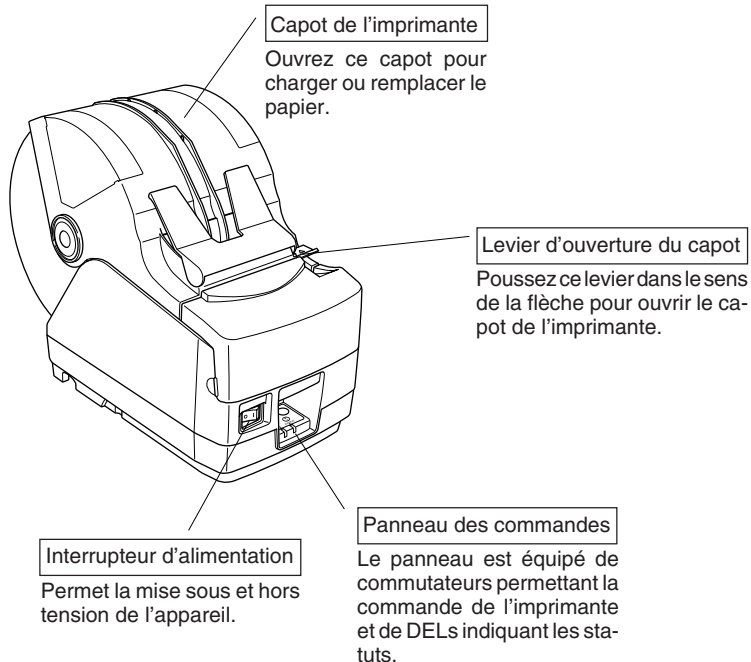

Emplacement de l'imprimante

Avant de déballer l'imprimante, déterminez l'emplacement où vous souhaitez l'installer. Veuillez observer les points ci-dessous lors de votre choix.

- ✓ Choisissez une surface stable et de niveau sur laquelle l'imprimante ne sera exposée à aucune vibration.
- ✓ Assurez-vous que l'emplacement dispose d'une prise secteur proche et d'accès aisé.
- ✓ Assurez-vous que la distance entre l'imprimante et l'ordinateur-hôte vous permet de les raccorder aisément.
- ✓ Assurez-vous que l'imprimante n'est pas exposée directement aux rayons du soleil.
- ✓ Tenez l'imprimante à l'écart des sources de chaleur importante, telles que les appareils de chauffage, etc.
- ✓ Assurez-vous que le lieu où vous souhaitez installer l'imprimante est propre, sec et n'est pas poussiéreux.
- ✓ Assurez-vous que la prise secteur à laquelle vous raccordez l'imprimante délivre une tension stable. Evitez de raccorder l'imprimante à la prise secteur d'un circuit alimentant de gros consommateurs de courant, tels qu'un photocopieur, réfrigérateur, etc.
- ✓ Assurez-vous que le lieu où vous installez l'imprimante n'est pas excessivement humide.

AVERTISSEMENT

- ✓ Éteignez immédiatement l'appareil en cas de dégagement de fumée ou d'odeur anormale ou en cas de bruit inhabituel. Débranchez immédiatement l'appareil et demander conseil à votre revendeur.
- ✓ Ne tentez jamais de réparer l'appareil vous-même. Une réparation mal effectuée pose un risque de danger.
- ✓ Ne démontez ou ne modifiez jamais l'appareil. Une altération de l'appareil risque de se traduire par des blessures, un incendie ou un choc électrique.

3. Consommables et adaptateur secteur

Il convient d'utiliser exclusivement les types de papier figurant dans le tableau ci-dessous. Veuillez également à utiliser l'adaptateur secteur qui figure dans le tableau. L'utilisation d'un type de papier et d'adaptateur ne figurant pas dans le tableau risque d'endommager l'imprimante, de causer un incendie ou une décharge électrique.

(1) Rouleau de papier, caractéristiques

Papier thermique

Épaisseur: 65 à 150 μm

Largeur: 44,5 \pm 0,5 à 82,5 \pm 0,5 mm

Diamètre extérieur du rouleau

: Max. ϕ 180 mm

(Lors de l'utilisation du chargement du papier par simple dépôt du rouleau dans l'imprimante)

: Max. ϕ 170 mm

(Lors de l'utilisation de l'axe de rouleau de papier)

Largeur du rouleau de papier: 45^{+0,5}₋₁ à 83^{+0,5}₋₁ mm

Diamètre extérieur/intérieur du support de rouleau

| Épaisseur du papier | Extérieur du support de rouleau | Intérieur du support de rouleau |
|-------------------------|---------------------------------|---------------------------------|
| 65 – 100 μm | Max. ϕ 40 \pm 1 mm | Max. ϕ 25,4 \pm 1 mm |
| 100 – 150 μm | Max. ϕ 58 \pm 1 mm | Max. ϕ 50,8 \pm 1 mm |

Surface imprimée: Bord extérieur du rouleau

Extrémité arrière: Ne pas utiliser de colle pour immobiliser le rouleau de papier ou son noyau.

Ne pas plier l'extrémité arrière du papier.

(2) Papier conseillé

Mitsubishi paper mills limited

T8037 (tickets), 85 μm (épaisseur)

TF8067 (tickets), 84 μm (épaisseur)

TF8075 (tickets), 85 μm (épaisseur)

KANZAN

KLS46 (tickets)

KPO460 (tickets)

Kanzaki Specialty Papers Inc. (KSP)

Lotto482 (tickets), 84 μm (épaisseur)

Suivant le type et l'épaisseur du papier, il peut être nécessaire de changer le réglage de clarté d'impression. Pour changer le réglage de la clarté d'impression, utilisez la commande de réglage de clarté d'impression <ESC><RS>'d'n ou les réglage de commutateur de carte d'extension de mémoire. Reportez-vous au manuel de programmation séparé pour les détails.

(3) Adaptateur secteur (option)

Nom du modèle: PS60

Entrée: CA100 à 240 V, 50/60 Hz

Sortie: CC24±5%, 2,0 A (charge de 10 sec. à 5,0 A max.)

 **ATTENTION**

Pour obtenir des informations concernant le papier recommandé, consultez l'adresse URL suivante :

<http://www.star-m.jp/eng/dl/dl02.htm>

4. Câbles de connexion et adaptateur secteur

4-1. Câble d'interface

Le câble d'interface n'est pas livré. Veuillez utiliser un câble conforme aux caractéristiques.

⚠ ATTENTION

Avant de connecter ou déconnecter le câble d'interface, veillez à ce que l'imprimante et tous les appareils qui y sont connectés soient hors tension. Veillez également à débrancher le câble d'alimentation de la prise secteur.

4-1-1. Câble d'interface série (RS-232C)

- (1) Assurez-vous que l'imprimante est hors tension.
- (2) Connectez le câble d'interface à la borne figurant sur le panneau arrière de l'imprimante.
- (3) Serrez les vis du connecteur.

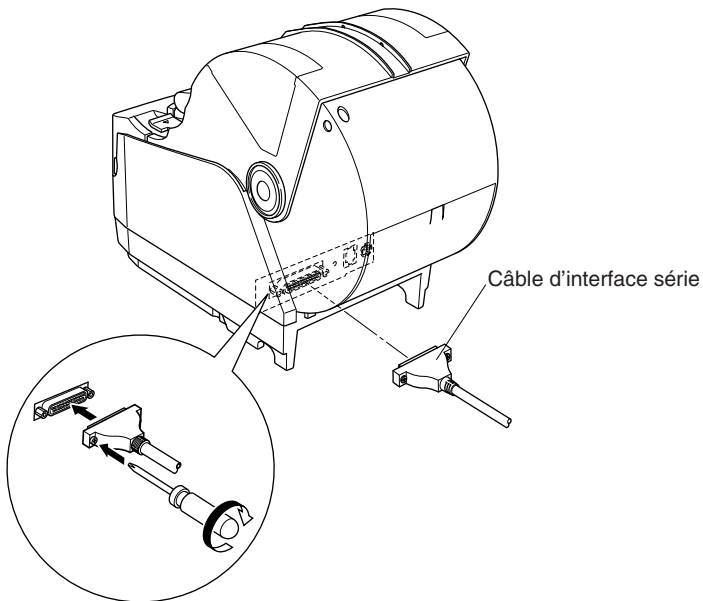

4-1-2. Interface parallèle

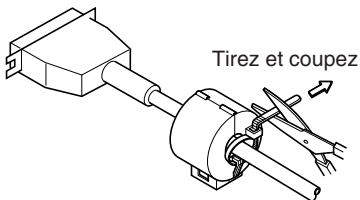
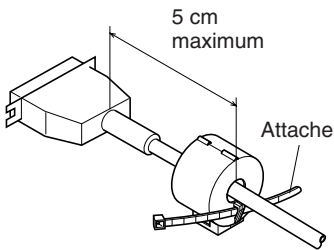
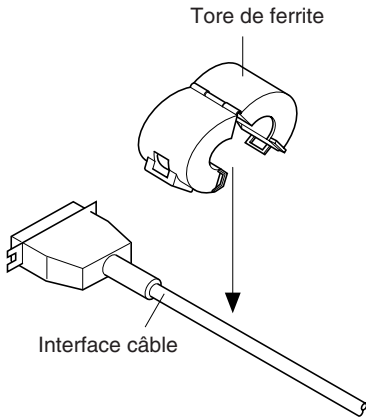
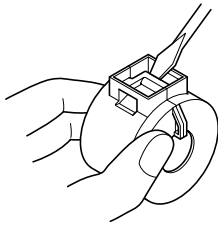

(1) Assurez-vous que l'imprimante est hors tension.

(2) Modèle avec interface parallèle seulement: fixez la grande gaine en ferrite sur le câble comme illustré.

(3) Passez l'attache dans le tore de ferrite.

(4) Passez l'attache autour du tore de ferrite et serrez-la. Coupez l'extrémité de l'attache à l'aide de ciseaux.

- (5) Connectez le câble d'interface à la borne figurant sur le panneau arrière de l'imprimante.
- (6) Attachez les fermoirs du connecteur.

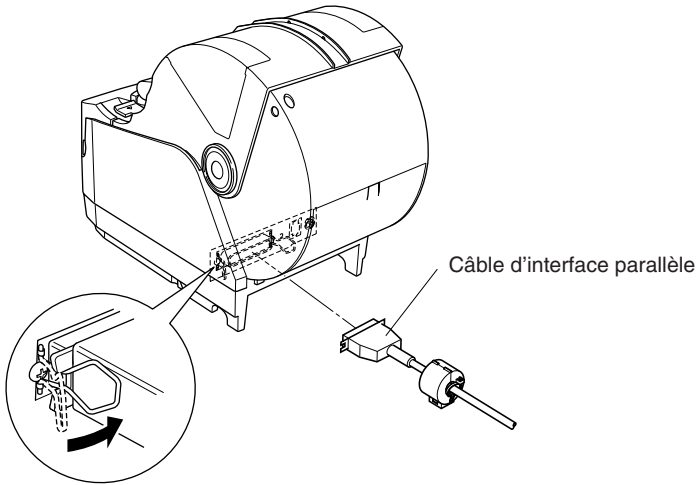

4-1-3. Branchement d'un câble USB

- (1) Assurez-vous que l'imprimante est hors tension.
- (2) Attachez le tore de ferrite au câble USB conformément à l'illustration ci-dessous, et veillez à passer le câble par le support de câble illustré.

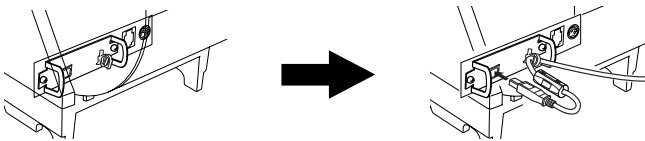

4-1-4. Branchement d'un câble ethernet

- (1) Assurez-vous que l'imprimante est hors tension.
- (2) Attachez le tore de ferrite au câble ethernet conformément à l'illustration.
- (3) Passez le collier de serrage par le tore de ferrite.
- (4) Passez le collier de serrage autour du câble et immobilisez ce dernier. Coupez l'extrémité excédentaire du collier à l'aide d'une paire de ciseaux.
- (5) Branchez le câble ethernet au connecteur de la carte interface et à votre ordinateur.

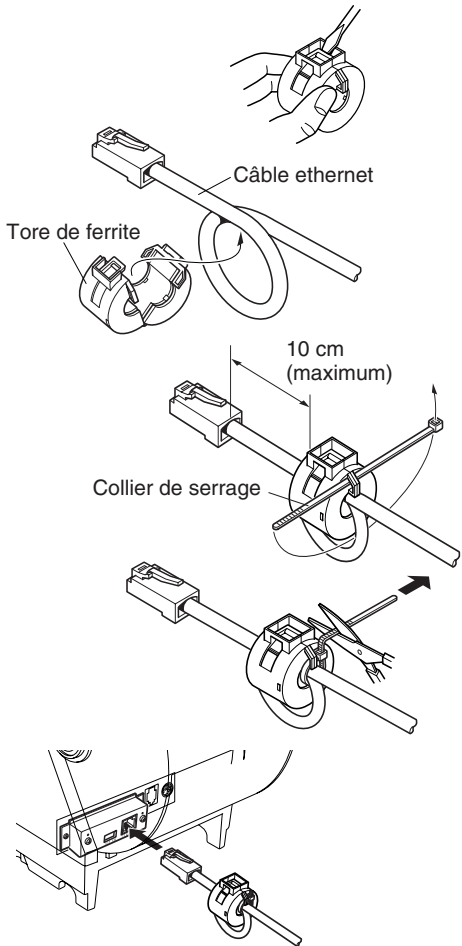

4-2. Raccordement d'une sonnerie

Vous pouvez raccorder une sonnerie à l'imprimante à l'aide d'une fiche modulaire. Nous expliquons ci-dessous comment faire le raccordement proprement dit. Pour les détails sur le type de fiche modulaire à utiliser, reportez-vous à la page 149. Notez que le fil ou la fiche modulaires ne sont pas fournis avec l'imprimante. Vous devrez donc vous les procurer.

⚠ ATTENTION

Assurez-vous que l'imprimante est hors tension, qu'elle est débranchée de la prise secteur et que l'ordinateur est hors tension avant d'effectuer les connexions.

Connectez le câble de la sonnerie à la borne figurant sur le panneau arrière de l'imprimante.

⚠ ATTENTION

*Ne connectez pas une ligne de téléphone à la borne de la sonnerie, sous peine de risquer d'endommager l'imprimante.
Pour des raisons de sécurité, il convient également de ne pas brancher la sonnerie en cas de risque de survolage.*

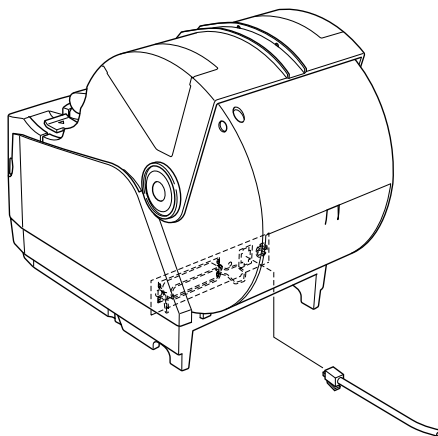

4-3. Connexion de l'adaptateur secteur optionnel

Remarque: Avant de connecter ou déconnecter l'adaptateur secteur, veillez à ce que l'imprimante et tous les appareils qui y sont connectés soient hors tension. Veillez également à débrancher le câble d'alimentation de la prise secteur.

(1) Connectez l'adaptateur secteur au câble d'alimentation.

Remarque: Utilisez exclusivement l'adaptateur secteur et le câble d'alimentation destinés à l'imprimante.

(2) Connectez l'adaptateur secteur à la borne de l'imprimante.

(3) Branchez la prise du câble d'alimentation à la prise secteur.

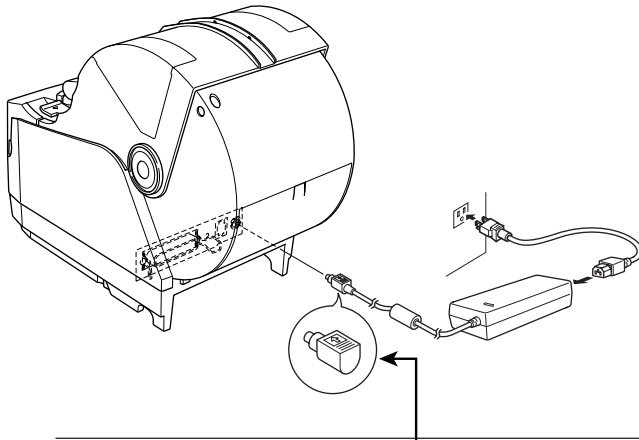

⚠ ATTENTION

Lorsque vous débranchez le câble, saisissez la prise du câble pour tirer dessus. Vous pourrez débrancher plus facilement la prise après avoir libéré le verrou.

Ne tirez pas violemment sur le câble car vous risqueriez d'endommager la prise.

4-4. Mise sous tension de l'imprimante

Assurez-vous d'avoir bien connecté l'adaptateur secteur comme décrit à la section 4-3.

(1) Placez l'interrupteur d'alimentation, situé à l'avant de l'imprimante, sur la position sous tension.

La DEL POWER s'allume au panneau des commandes.

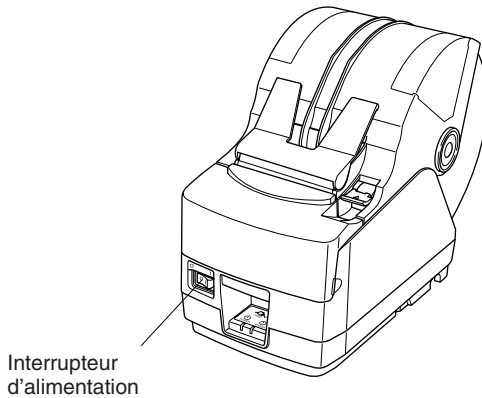

⚠ ATTENTION

Nous vous recommandons de débrancher l'imprimante du secteur lorsque vous ne comptez pas l'utiliser pendant une période prolongée. Par ailleurs, veillez lors de l'installation à ce que la prise secteur alimentant l'imprimante soit proche et d'accès facile.

4-5. Installation du câble

Installez le câble, comme indiqué sur le schéma ci-dessous.

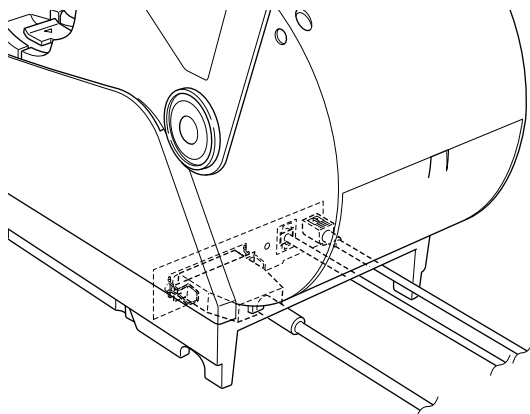
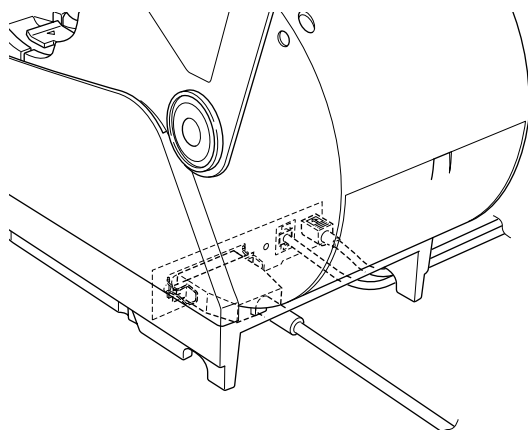
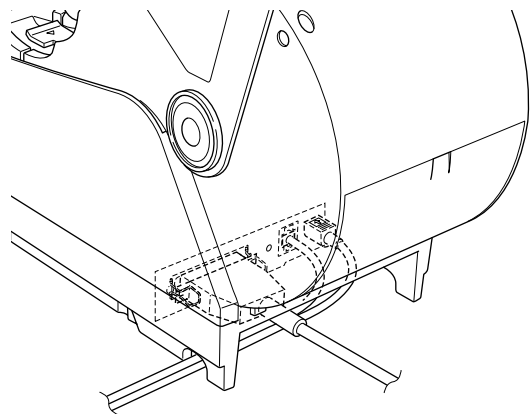

4-6. Installation du cache de l'interrupteur

L'installation de ce cache n'est pas nécessaire.

Ne l'installez que si vous souhaitez :

- éviter que l'interrupteur d'alimentation ne soit actionné par erreur ;
- vous assurer que personne ne peut l'actionner facilement.

Installez le cache, comme indiqué sur le schéma ci-dessous.

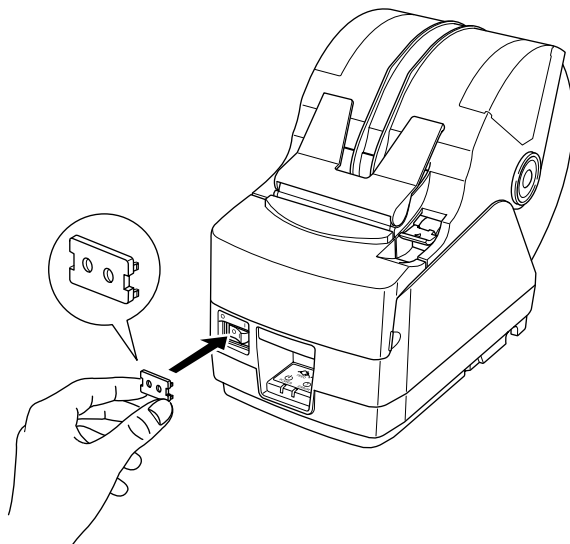

L'interrupteur peut être activé ON (I) et désactivé OFF (O) en insérant un instrument étroit (stylo à bille, par ex.) dans les orifices du cache de l'interrupteur.

⚠ ATTENTION

Nous vous recommandons de débrancher l'imprimante du secteur lorsque vous ne comptez pas l'utiliser pendant une période prolongée. Par ailleurs, veillez lors de l'installation à ce que la prise secteur alimentant l'imprimante soit proche et d'accès facile.

5. Panneau de commande et autres fonctions

5-1. Panneau de commande

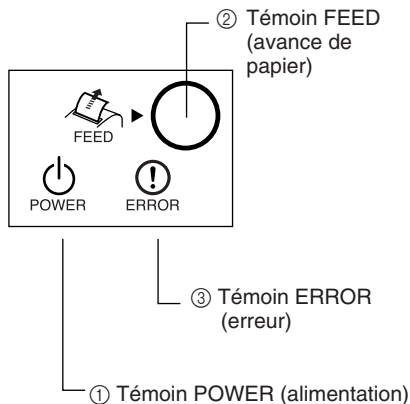

- ① Témoin POWER (DEL verte)
S'allume quand l'appareil est sous tension.
- ② Témoin FEED
Appuyez sur la touche FEED pour faire avancer le papier.
- ③ Témoin ERROR (DEL rouge)
Indique des erreurs variées en combinaison avec le témoin POWER.

5-2. Erreurs

(1) Erreur récupérable automatiquement

| Description de l'erreur | Témoin POWER | Témoin ERROR | Conditions de récupération |
|---|-------------------------------------|--------------|--|
| Détection de température élevée de la tête | Clignote à 0,5 seconde d'intervalle | Hors tension | Récupération automatique après refroidissement de la tête. |
| Erreur d'ouverture du capot de l'imprimante | Sous tension | Sous tension | Récupération automatique après fermeture du capot de l'imprimante. |

(2) Erreur récupérable

| Description de l'erreur | Témoin POWER | Témoin ERROR | Conditions de récupération |
|-----------------------------|--------------|---------------------------------------|---|
| Erreur de découpe du papier | Hors tension | Clignote à 0,125 seconde d'intervalle | Récupération si l'unité de découpage revient dans sa position d'origine après la mise hors tension et sous tension. |

Remarque:

- 1) Si l'unité de découpage ne revient pas dans sa position d'origine ou n'effectue pas le mouvement initial, la récupération est impossible.
- 2) Si le papier est coincé, mettez l'appareil hors tension, dégagez le bourrage de papier, puis mettez l'appareil sous tension.

(3) Erreur non récupérable

| Description de l'erreur | Témoin POWER | Témoin ERROR | Conditions de récupération |
|--------------------------|--------------|--------------------------------------|--|
| Erreur de mémoire vive | Hors tension | Clignote à 1,0 seconde d'intervalle | Ce n'est pas une erreur récupérable. Consultez votre revendeur pour des réparations. |
| Erreur de mémoire EERROM | Hors tension | Clignote à 0,75 seconde d'intervalle | Ce n'est pas une erreur récupérable. Consultez votre revendeur pour des réparations. |
| Erreur de mémoire flash | Hors tension | Clignote à 0,5 seconde d'intervalle | Ce n'est pas une erreur récupérable. Consultez votre revendeur pour des réparations. |
| Erreur de thermistor | Hors tension | Clignote à 1,5 seconde d'intervalle | Ce n'est pas une erreur récupérable. Consultez votre revendeur pour des réparations. |
| Erreur d'alimentation | Hors tension | Clignote à 2 seconde d'intervalle | Ce n'est pas une erreur récupérable. Consultez votre revendeur pour des réparations. |

Remarque:

- 1) Si une erreur non récupérable se produit, mettez immédiatement l'appareil hors tension.
- 2) Quand une erreur d'alimentation se produit, il est possible que le bloc d'alimentation soit en panne.
Pour d'autres erreurs non récupérable, veuillez consulter votre revendeur pour des réparations.

(4) Erreur de détection de papier

| Description de l'erreur | Témoin POWER | Témoin ERROR | Conditions de récupération |
|--|--------------|-------------------------------------|---|
| Erreur de sortie de papier | Sous tension | Clignote à 0,5 seconde d'intervalle | Récupération automatique après chargement d'un nouveau rouleau de papier et fermeture du capot de l'imprimante. |
| Le rouleau de papier est presque terminé | Sous tension | Clignote à 2 seconde d'intervalle | Les indicateurs signalent la fin proche du rouleau, mais l'imprimante continue à imprimer. |

5-3. Auto-impression

(1) Essai d'impression

Mettez l'appareil sous tension tout en maintenant la touche FEED enfoncée. L'essai d'impression sera effectué en fonction du numéro de version, des réglages du commutateur DIP et des réglages de commutateur de carte d'extension de mémoire.

```
*** TSP1000 Ver1.00
```

```
Interface : Parallel
```

```
DIP Switch 1  
Sw 12345678  
On *******  
Off
```

(2) Mode de vidage hexadécimal

Ouvrez le capot de l'imprimante, puis mettez l'appareil sous tension tout en maintenant la touche FEED enfoncée. Quand le capot est fermé, "**** HEX DUMP PRINTING ****" est imprimé et l'imprimante entre en mode de vidage hexadécimal.

Chacun des signaux envoyés par l'ordinateur à l'imprimante sera imprimé dans le code hexadécimal.

Cette fonction vous permet de vérifier si un code de commande envoyé à l'imprimante par le programme utilisé est correct ou non. La ligne finale n'est pas imprimée si ses données sont inférieures à une ligne complète. Néanmoins, si vous appuyez sur la touche FEED, la ligne finale sera imprimée. Pour désactiver ce mode, il est nécessaire de mettre l'imprimante complètement hors tension.

```
*** HEX DUMP PRINTING ***
```

| | |
|-------------------------|-------------|
| 20 21 22 23 24 25 26 27 | !'#\$%&' |
| 28 29 2A 2B 2C 2D 2E 2F | ()*+,-./ |
| 30 31 32 33 34 35 36 37 | 01234567 |
| 38 39 3A 3B 3C 3D 3E 3F | 89:;<=>? |
| 40 41 42 43 44 45 46 47 | @ABCDEFG |
| 48 49 4A 4B 4C 4D 4E 4F | HJKLMNO |
| 50 51 52 53 54 55 56 57 | PQRSTUVWXYZ |

6. Chargement du rouleau de papier

6-1. Chargement du rouleau de papier

Le chargement du rouleau de papier dans cette imprimante est différent selon le type de papier utilisé (rouleau de papier à chargement par simple dépôt ou rouleau de papier nécessitant l'utilisation de l'axe). Chargez le rouleau de papier en suivant les procédures figurant à la section 6-2.

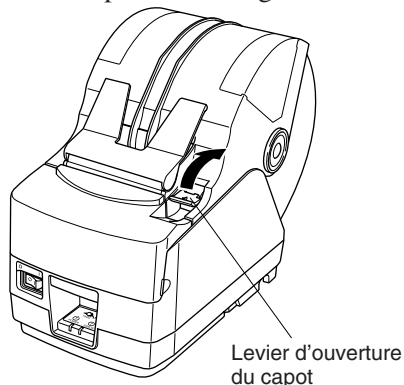

- (1) Poussez le levier d'ouverture du capot et ouvrez le capot de l'imprimante.
- (2) Mettez le rouleau de papier en place dans le creux tout en respectant son orientation, et tirez sur l'extrémité du papier.

Rouleau de papier

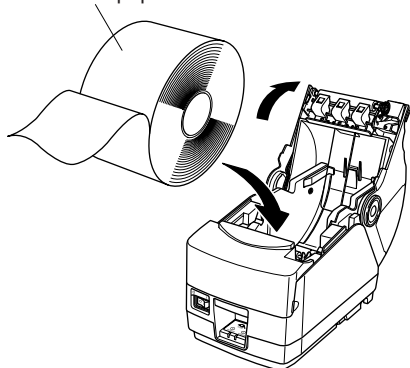

[Chargement du papier par simple dépôt]

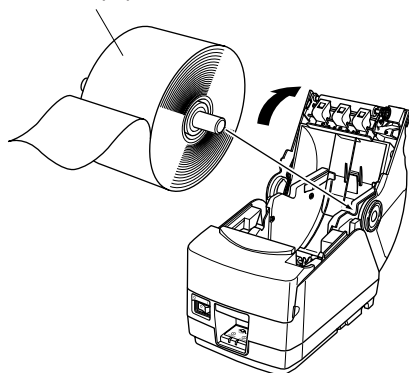
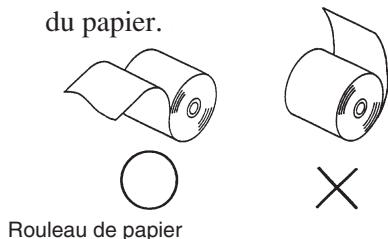

[Utilisation de l'axe]

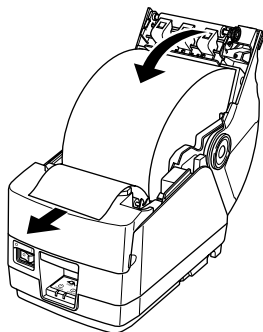

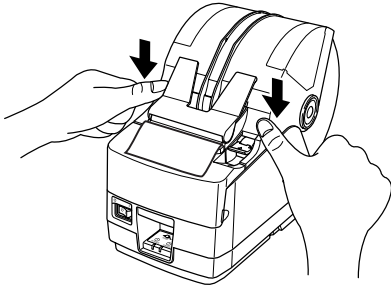

- (3) Tirez sur le papier afin de bien le tendre, puis appuyez de part et d'autre du capot de l'imprimante pour le fermer.

Remarque: Assurez-vous que le capot de l'imprimante est bien fermé.

- (4) Si le couvercle de l'imprimante est fermé après la mise sous tension, le coupe-papier coupe automatiquement la partie avant du papier.

Remarque: Si le papier n'est pas automatiquement coupé après la fermeture du capot, ouvrez à nouveau le capot, puis refermez-le avec soin.

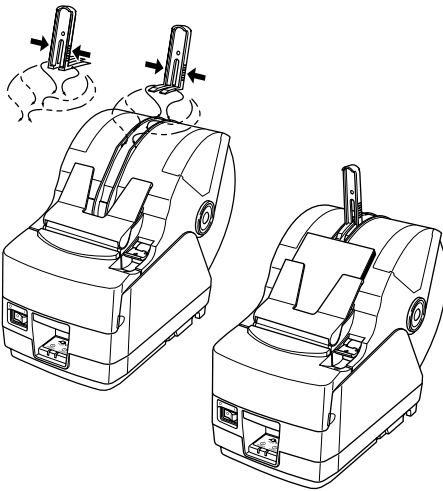

- (5) Si nécessaire, attachez la butée de papier au cache du rouleau de papier, comme illustré. Le bac de sortie peut recevoir jusqu'à 30 feuilles (largeur : 80 à 82,5 mm, épaisseur : 80 à 120 µm, longueur : 50 à 150 mm). Pour le papier d'une autre épaisseur ou d'une autre longueur, la limite est de 10 feuilles.

Remarque: Veillez à adapter la position de la butée du papier en fonction de la longueur de feuille utilisée. (Référez-vous au tableau suivant.)

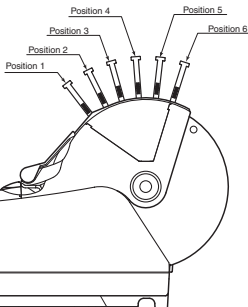

| | Longueur de feuille (mm) |
|------------|--------------------------|
| Position 1 | 50 – 100 |
| Position 2 | 100 – 120 |
| Position 3 | 120 – 140 |
| Position 4 | 140 – 160 |
| Position 5 | 160 – 180 |
| Position 6 | 180 – 200 |

⚠ AVERTISSEMENT

- *Ne pas toucher la lame du coupe-ruban.*
 - *Une lame se trouve dans la fente de sortie de papier. Il est fortement déconseillé de mettre sa main dans la fente de sortie de papier non seulement pendant l'impression mais aussi en toute autre circonstance, même quand l'impression n'est pas effectuée.*
 - *Le capot de l'imprimante peut être ouvert pour remplacer le papier. Néanmoins, la lame du coupe-ruban se trouvant à l'intérieur du capot de l'imprimante, veuillez faire attention à ne pas rapprocher votre figure ou vos mains trop près de la lame du coupe-ruban.*
 - *Pendant et immédiatement après l'impression, la zone autour de la tête d'impression thermique est très chaude. Ne pas la toucher car vous pourriez vous brûler.*
-

⚠ ATTENTION

- *Ne pas faire fonctionner le levier d'ouverture du capot tout en appuyant sur le capot de l'imprimante avec la main.*
 - *Ne pas tirer sur le papier pour le faire sortir quand le capot de l'imprimante est fermé.*
 - *L'élément de chauffage et le circuit imprimé de la tête d'impression thermique sont facilement endommagés. Ne pas les toucher avec des objets métalliques, du papier de verre, etc.*
 - *La qualité d'impression peut être affectée si l'élément de chauffage de la tête d'impression thermique est souillé par un contact avec vos mains, Ne pas toucher l'élément de chauffage de la tête d'impression thermique.*
 - *Le circuit imprimé de la tête d'impression thermique peut être endommagé par l'électricité statique. Ne touchez jamais directement le circuit imprimé.*
 - *La qualité d'impression et la durée de vie utile de la tête d'impression thermique ne peuvent pas être garanties si un papier quelconque différent de celui recommandé est utilisé. En particulier, le papier contenant les éléments suivants: Na⁺, K⁺, Cl⁻, peut réduire de façon importante la durée de vie utile de la tête d'impression thermique. Veuillez prendre des précautions.*
 - *Ne pas faire fonctionner l'imprimante si de l'humidité provenant de la condensation, etc., est présente sur la surface avant de la tête.*
-

6-2. Méthodes de chargement du papier

Cette imprimante permet d'utiliser deux méthodes de chargement : en utilisant l'axe de rouleau de papier ou non. L'axe de rouleau de papier n'est pas utilisé pour le chargement du papier par simple dépôt du rouleau. Sélectionnez la méthode de chargement de papier en vous aidant du tableau suivant, selon le type de papier utilisé.

| Largeur du papier (mm) Epaisseur du papier (μm) | $44,5 \leq \text{Largeur} < 79,5$ | $79,5 \leq \text{Largeur} \leq 82,5$ |
|---|--|---|
| 65 Epaisseur < 80 | Utilisez l'axe de rouleau de papier (*1, *4) | Utilisez l'axe de rouleau de papier (*2) |
| $80 \leq \text{Epaisseur} \leq 120$ | Utilisez l'axe de rouleau de papier (*1, *4) | Utilisez le chargement par simple dépôt du rouleau de papier (*3) |
| $120 < \text{Epaisseur} \leq 150$ | Utilisez l'axe de rouleau de papier (*1) | Utilisez l'axe de rouleau de papier (*1) |

Remarque :

- *1: Diamètre extérieur maximum du rouleau : 150 mm
- *2: Diamètre extérieur maximum du rouleau : 170 mm
- *3: Diamètre extérieur maximum du rouleau : 180 mm
- *4: La vitesse d'impression supérieure (réglée par défaut en usine) doit être remplacée par la vitesse moyenne (140 mm/sec.). Pour changer la vitesse d'impression, utilisez la commande réglage de la vitesse d'impression <ESC><RS> Rn. Reportez-vous au manuel de programmation séparé pour les détails.

6-3. Réglage du support de rouleau de papier

Il existe deux supports de rouleau de papier de taille différente : les supports de rouleau de papier 1 pour le papier avec un rouleau intérieur d'un diamètre de 1 pouce et les supports de rouleau de papier 2 pour le papier avec un rouleau intérieur d'un diamètre de 2 pouces. Sélectionnez les supports de rouleau en fonction du type de rouleau de papier utilisé.

- (1) Installez les supports de rouleau de chaque côté de l'axe de rouleau de papier.
- (2) Réglez les positions sur les supports de rouleau en fonction de la largeur du rouleau de papier utilisé.
- (3) Insérez les supports et l'axe de rouleau dans le rouleau de papier.

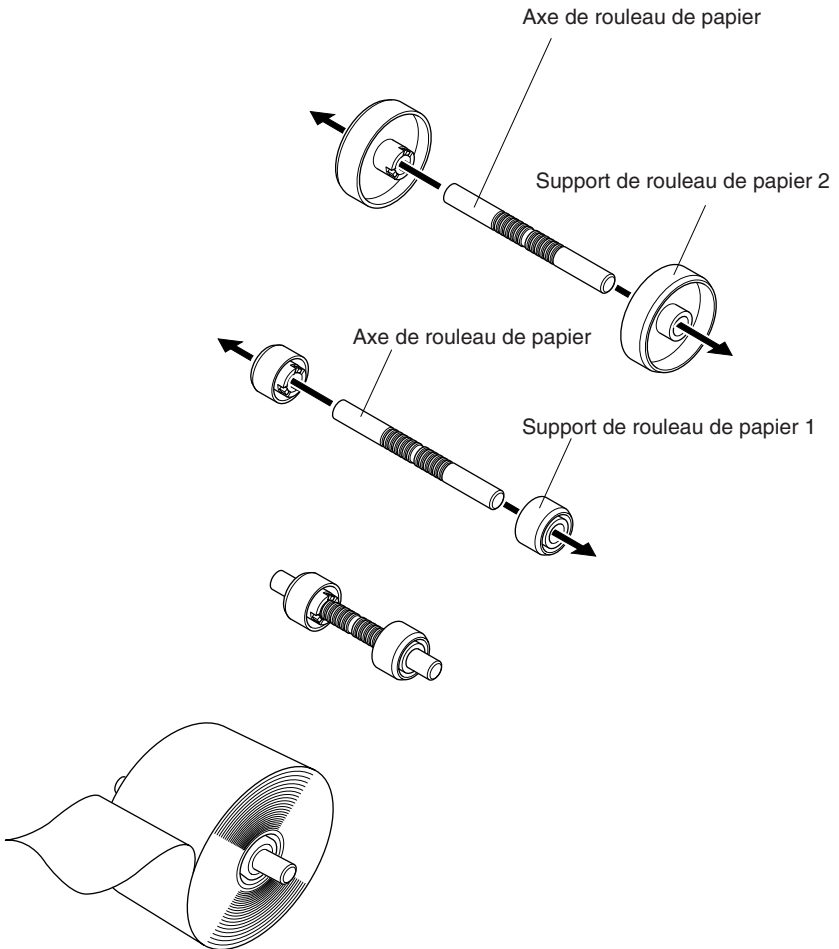

6-4. Réglage des guides papier

Lorsque l'imprimante sort de l'usine, les guides papier et les guides supérieurs sont réglés pour des rouleaux de la largeur suivante.

Largeur du papier : $79,5 \pm 0,5$ mm (TSP1043)

Largeur du papier : $82,5 \pm 0,5$ mm (TSP1045)

Lorsque vous utilisez un rouleau de papier d'une largeur différente de celles figurant dans la liste ci-dessus, effectuez la procédure suivante pour régler les guides papier. Pour régler les guides supérieurs, reportez-vous à "6-5 Réglage des guides supérieurs".

- (1) Dévissez les quatre vis.
- (2) Réglez les guides papier gauche et droite en fonction de la largeur du rouleau de papier, en veillant à laisser un espace d'environ 0,5 mm entre chaque guide et le bord du papier.

Les graduations de la plaque métallique à l'intérieur de l'imprimante sont divisées en segments de 1 mm entre les repères \blacklozenge . Les deux repères \blacktriangledown au-dessus des graduations sont utilisés pour le papier d'une largeur de 57,5 mm et les deux repères \blacklozenge sont utilisés pour le papier d'une largeur de 79,5 mm. Par conséquent, pour les rouleaux de papier d'une largeur de 79,5 mm, positionnez chaque guide papier 0,5 mm à l'extérieur du repère \blacklozenge respectif. Si nécessaire, les vis 2 et 3 peuvent être déposées et installées dans les trous adjacents.

- (3) Revissez les quatre vis.

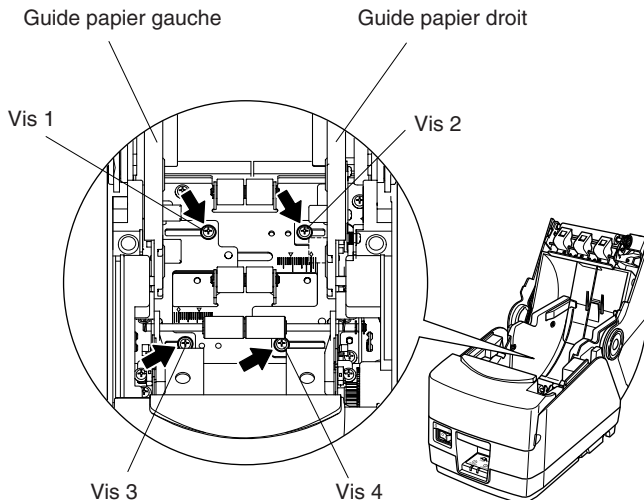

6-5. Réglage des guides supérieurs

Lorsque l'imprimante sort de l'usine, les guides supérieurs sont réglés pour des rouleaux d'une largeur de 79,5–82,5 mm. Lorsque vous utilisez un rouleau de papier d'une largeur différente, effectuez la procédure suivante pour régler les guides supérieurs.

- (1) Dévissez les deux vis des guides supérieurs gauche et droit.
- (2) Réglez les guides supérieurs gauche et droit selon la largeur du rouleau de papier, en veillant à ce que chaque guide soit environ 2 mm à l'intérieur du bord du papier.

Les graduations de la plaque métallique sur le capot sont divisées en segments de 1 mm. Les deux repères ▲ au-dessous des graduations sont utilisés pour le papier d'une largeur de 57,5 mm et les deux repères ◆ sont utilisés pour le papier d'une largeur de 79,5 mm (également utilisé pour le papier d'une largeur de 82,5 mm).

Si nécessaire, les vis des guides supérieurs gauche et droit peuvent être retirées et installées dans les trous adjacents. Si le rouleau de papier est d'une largeur de 50 mm ou moins, retirez le guide central supérieur en dévissant sa vis, puis réglez les guides supérieurs gauche et droit.

Remarque :

Lorsque vous réglez les guides supérieurs, veillez à ne pas pincer les fils et à ne pas trop appuyer sur ceux-ci.

- (3) Revissez les deux vis.

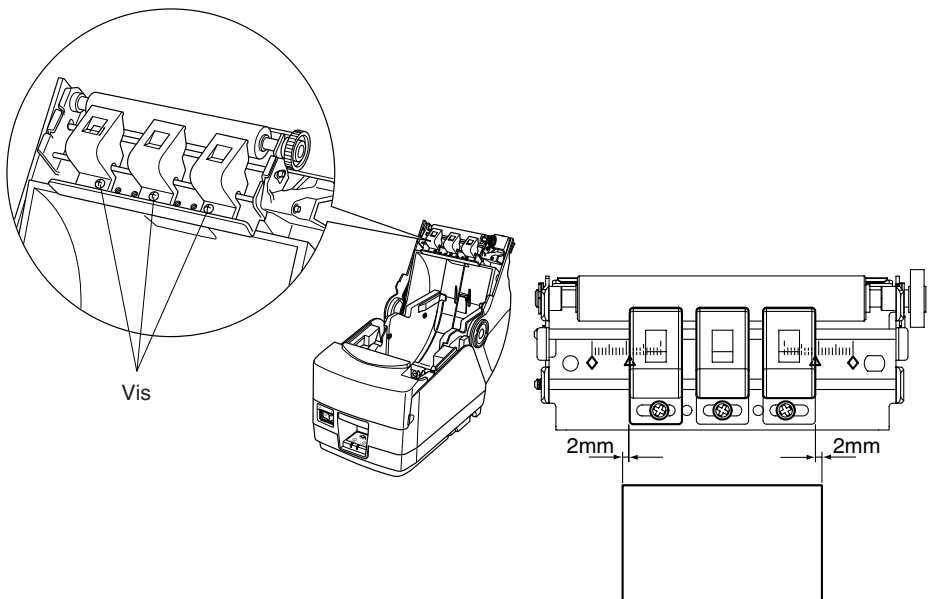

7. Réglage du capteur de fin de rouleau

Utilisez la procédure suivante pour régler le capteur de fin de rouleau conformément à la taille du rouleau de papier utilisé.

- ① Ouvrez le capot de l'imprimante.
- ② Déterminez la position correcte du système de réglage à partir des trois positions suivantes, en fonction de la méthode de chargement du papier et du diamètre du rouleau intérieur du rouleau de papier.
 - Position 1 : Lors de l'utilisation du chargement du papier par simple dépôt du rouleau dans l'imprimante
 - Position 2 : Utilisation du support 2 de rouleau de papier (rouleau intérieur $\varnothing 50,8$ mm)
 - Position 3 : Utilisation du support 1 de rouleau de papier (rouleau intérieur $\varnothing 25,4$ mm)
- ③ Insérez la pointe d'un stylo à bille ou d'un instrument similaire dans le trou du curseur de réglage, puis tout en appuyant sur le curseur de réglage, faites-le glisser jusqu'à la position souhaitée.

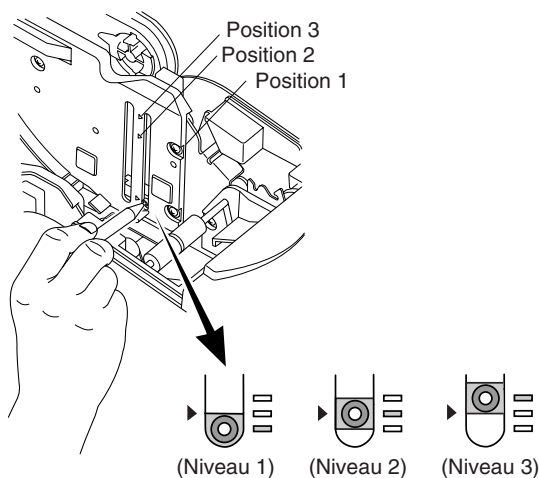

Le tableau suivant indique les quantités de papier restant qui peuvent être détectées.

(1) Position 1

| Épaisseur du papier (μm) | Quand vous utilisez un rouleau de papier dont le diamètre intérieur du support est de (A) : $\varnothing 25,4$ et le diamètre extérieur de (B) : $\varnothing 40$ | | | | | |
|---------------------------------------|---|------------------|------------------|---|----------|----------|
| | Diamètre détecté (C) (Env. mm) | | | Longueur de papier restante (Env. m) | | |
| | Niveau 1 | Niveau 2 | Niveau 3 | Niveau 1 | Niveau 2 | Niveau 3 |
| 80 | $\varnothing 44$ | $\varnothing 48$ | $\varnothing 52$ | 3,5 | 7,5 | 12,5 |
| 105 | | | | 1,5 | 4,5 | 7,5 |

(2) Position 2

| Épaisseur du papier (μm) | Quand vous utilisez un rouleau de papier dont le diamètre intérieur du support est de (A) : $\phi 25,4$ et le diamètre extérieur de (B) : $\phi 40$ | | | | | |
|---------------------------------------|---|-----------|----------|---|----------|----------|
| | Diamètre détecté (C) (Env. mm) | | | Longueur de papier restante (Env. m) | | |
| | Niveau 1 | Niveau 2 | Niveau 3 | Niveau 1 | Niveau 2 | Niveau 3 |
| 65 | — | $\phi 45$ | — | — | 5,6 | — |
| 80 | | | | | 4,4 | |
| 105 | | | | | 3,2 | |

(3) Position 3

| Épaisseur du papier (μm) | Quand vous utilisez un rouleau de papier dont le diamètre intérieur du support est de (A) : $\phi 50,8$ et le diamètre extérieur de (B) : $\phi 58$ | | | | | |
|---------------------------------------|---|-----------|----------|---|----------|----------|
| | Diamètre détecté (C) (Env. mm) | | | Longueur de papier restante (Env. m) | | |
| | Niveau 1 | Niveau 2 | Niveau 3 | Niveau 1 | Niveau 2 | Niveau 3 |
| 150 | — | $\phi 69$ | — | — | 6,5 | — |

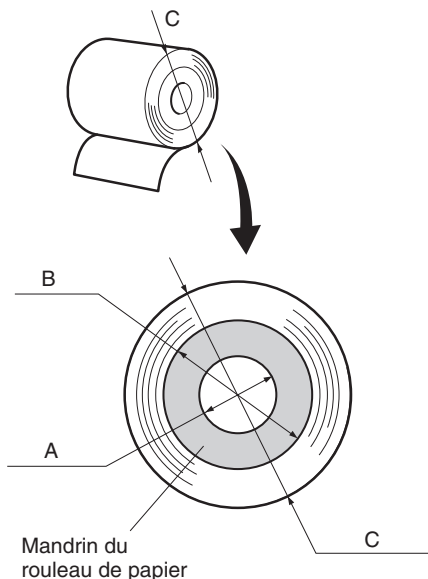
**Remarque:**

- 1) Avant sa sortie de l'usine, le système de réglage est réglé en position 1, niveau 2.
- 2) La dimension C et la longueur de papier restante sont les valeurs calculées. Il est possible qu'il y ait quelques différences dans le mécanisme actuel.
- 3) Les autres longueurs de feuille figurant dans le tableau servent de référence uniquement. Réglez le capteur de fin de rouleau en fonction du papier utilisé.
- 4) Si vous utilisez du papier épais (épaisseur égale ou supérieure à 100 μm) et que le système de réglage est sur la position 1, il y aura un certain relâchement au niveau du rouleau de papier, ce qui peut entraîner des variations lors de la détection. Réglez sur le niveau 3.

8. Prévention et correction de bourrages de papier

8-1. Prévention des bourrages de papier

Il convient de ne jamais toucher le papier pendant son éjection et avant qu'il soit coupé. Appuyer ou tirer sur le papier pendant son éjection risque de provoquer un bourrage, des problèmes de coupure ou d'avance de ligne.

8-2. Correction de bourrages de papier

En cas de bourrage de papier, procédez comme suit afin d'y remédier :

(1) Mettez l'appareil hors tension.

(2) Poussez le levier d'ouverture du capot afin de l'ouvrir.

Si le couvercle de l'imprimante ne s'ouvre pas sur les modèles à coupe-papier automatique, c'est que celui-ci n'est pas à sa position d'origine. Dans ce cas, ramenez le coupe-papier à sa position d'origine en suivant les instructions de la section 8-3. Ouvrez le couvercle de l'imprimante lorsque le papier coincé a été retiré.

(3) Retirez le papier bloqué.

ATTENTION

Veillez à ne pas endommager l'imprimante lors du retrait du papier bloqué.

Veillez particulièrement à ne pas toucher la tête d'impression thermique en raison de sa fragilité.

(4) Veillez à insérer le rouleau de papier tout droit et refermez avec soin le capot de l'imprimante.

Remarque:

1) Le papier doit être placé bien droit. Si vous refermez le capot de l'imprimante alors que le papier est de travers (voir illustration), un bourrage peut se produire.

2) Verrouillez le capot de l'imprimante en appuyant sur les deux côtés. Veillez bien à refermer correctement le capot.

(5) Mettez l'imprimante sous tension. Assurez-vous que la DEL ERROR n'est pas allumée.

Remarque: Tant que la DEL ERROR est allumée, l'imprimante n'accepte aucune commande. Il faut donc veiller à ce que le capot de l'imprimante soit verrouillé.

8-3. Libération d'une unité de découpage bloquée

Si l'unité de découpage automatique se bloque ou ne coupe pas le papier, suivez les étapes ci-dessous.

⚠ AVERTISSEMENT

Le travail sur l'unité de découpage étant dangereux, n'oubliez pas de mettre avant tout l'imprimante hors tension.

- (1) Réglez l'interrupteur d'alimentation sur la position hors tension OFF pour mettre l'imprimante hors tension.
- (2) Faites glisser le couvercle avant pour dégager l'unité de découpage automatique.
- (3) Enlevez le papier coincé.

⚠ ATTENTION

Faites attention à ne pas endommager l'imprimante pendant que vous enlevez le papier coincé.

La tête d'impression thermique étant particulièrement sensible, veillez à ne pas la toucher.

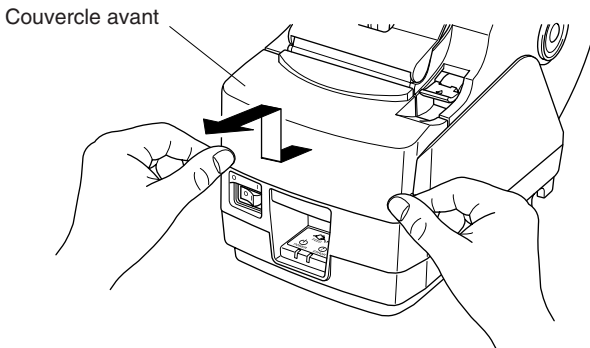

- (4) Si la lame mobile du coupe-papier dépasse, tournez le bouton dans le sens de la flèche afin de ramener la lame à sa position d'origine.
Quand la fenêtre de contrôle est complètement blanche, la lame mobile est dans sa position d'origine.

⚠ ATTENTION

- 1) *N'appliquez pas de pression excessive sur la lame mobile.*
 - 2) *Si la lame mobile dépasse trop, le capot de l'imprimante ne pourra pas être ouvert. Vous risquez d'endommager l'unité de découpage automatique en essayant d'ouvrir le capot de l'imprimante.*
-

- (5) Ouvrez le capot de l'imprimante, enlevez le papier coincé, puis remettez le rouleau de papier en place.
- (6) Installez le couvercle avant, puis réglez l'interrupteur d'alimentation sur la position sous tension.

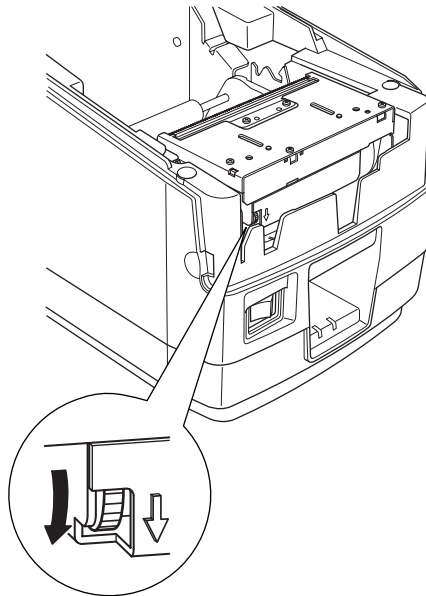

9. Nettoyage

Les caractères imprimés pourraient devenir partiellement illisibles en raison de l'accumulation de la poussière de papier et de crasse. Afin de prévenir ce genre de problème, il convient de nettoyer régulièrement la poussière qui s'accumule sur le support de papier, les passages du papier et la surface de la tête d'impression. Il est recommandé d'effectuer un tel nettoyage une fois tous les six mois ou après l'impression d'un million de lignes.

9-1. Nettoyage de la tête d'impression

Nettoyez la poussière noirâtre accumulée sur la surface de la tête d'impression thermique en l'essuyant avec de l'alcool isopropylique.

Remarque: La tête d'impression thermique est fragile, il convient donc de procéder avec précaution. Prenez soin de ne pas la griffer.

9-2. Nettoyage du support de papier

Nettoyez la poussière de papier accumulée sur le support de papier et sur les passages du papier à l'aide d'un chiffon doux.

INHALTSVERZEICHNIS

| | |
|--|------------|
| 1. Auspacken und Aufstellen | 65 |
| 1-1. Überprüfen | 65 |
| 2. Beschreibung und Bezeichnung der Geräteteile | 66 |
| 3. Verbrauchsteile und Netzteil | 68 |
| 4. Anschlußkabel und Netzteil | 70 |
| 4-1. Schnittstellenkabel | 70 |
| 4-2. Anschließen an eine Signaltongebereinheit | 74 |
| 4-3. Anschließen des optionalen Netzteils | 75 |
| 4-4. Einschalten | 76 |
| 4-5. Installieren der Kabel | 77 |
| 4-6. Einsetzen der Schalterabdeckung | 78 |
| 5. Bedienfeld und andere Funktionen | 79 |
| 5-1. Bedienfeld | 79 |
| 5-2. Fehler | 79 |
| 5-3. Selbstdruck | 81 |
| 6. Einlegen der Papierrolle | 82 |
| 6-1. Einlegen des Rollenpapiers | 82 |
| 6-2. Verfahren zum Papiereinlegen | 85 |
| 6-3. Einstellen des Rollenpapierhalters | 86 |
| 6-4. Einstellen der Papierführung | 87 |
| 6-5. Einstellen der oberen Führung | 88 |
| 7. Einstellung des Endanäherungs-Sensors | 89 |
| 8. Verhindern und Beheben von Papierstau | 91 |
| 8-1. Verhindern von Papierstau | 91 |
| 8-2. Beheben von Papierstau | 91 |
| 8-3. Freigeben eines gesperrten Schneidmessers | 92 |
| 9. Regelmäßige Reinigung | 94 |
| 9-1. Reinigen des Thermalkopfes | 94 |
| 9-2. Reinigen des Papierhalters | 94 |
| ANHANG | 128 |

Der Anhand dieser Bedienungsanleitung ist nur in englischer Sprache.

Bitte wenden Sie sich an die folgende Internet-Address:

<http://www.star-m.jp/eng/dl/dl02.htm>

wenn Sie die neueste Revision dieses Handbuches lesen möchten.

1. Auspacken und Aufstellen

1-1. Überprüfen

Sie den Kartoninhalt, und vergewissern Sie sich, daß alle unten abgebildeten Teile vorhanden sind.



Abb. 1-1 Auspacken

Falls Teile fehlen, wenden Sie sich zwecks Nachlieferung bitte an den Fachhandel, bei dem das Gerät gekauft wurde. Im Hinblick auf einen eventuellen zukünftigen Transport des Druckers empfiehlt es sich, den Lieferkarton und das gesamte Verpackungsmaterial aufzubewahren.

2. Beschreibung und Bezeichnung der Geräteteile

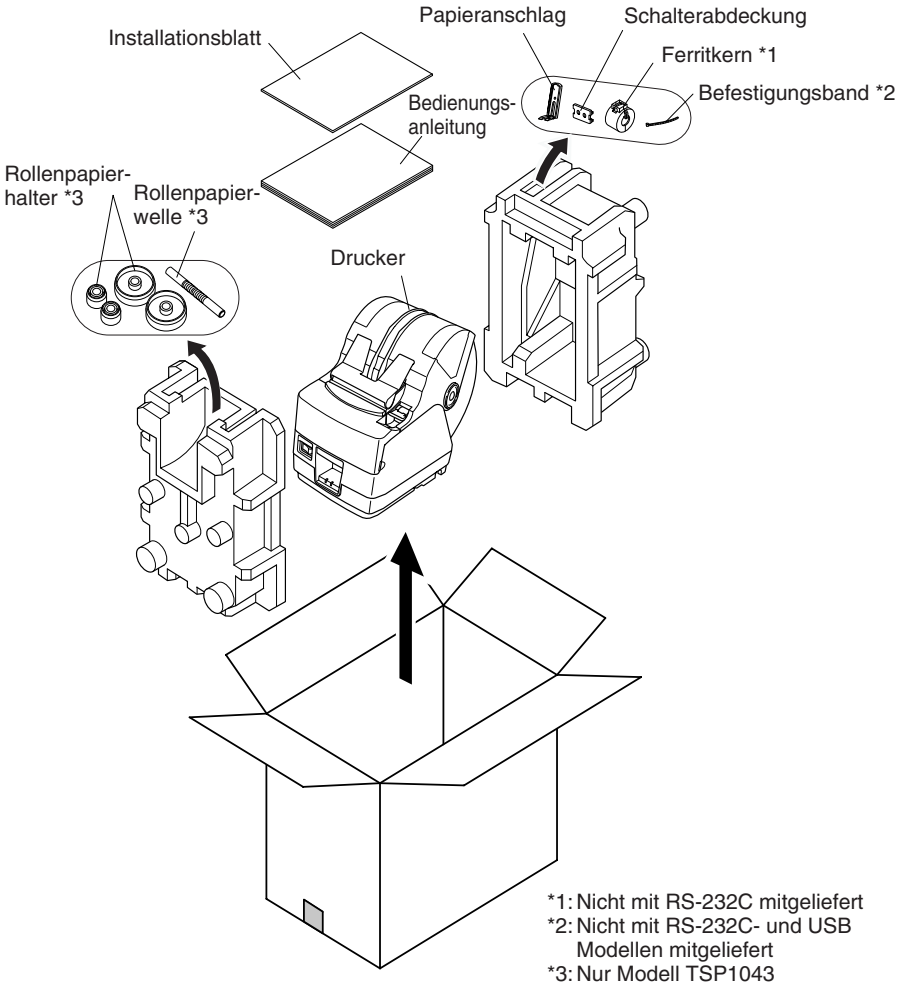
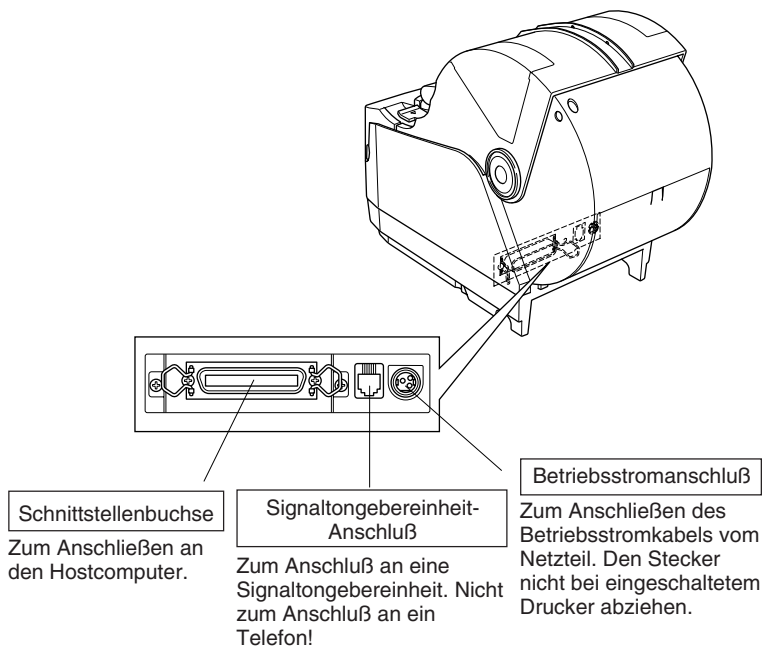
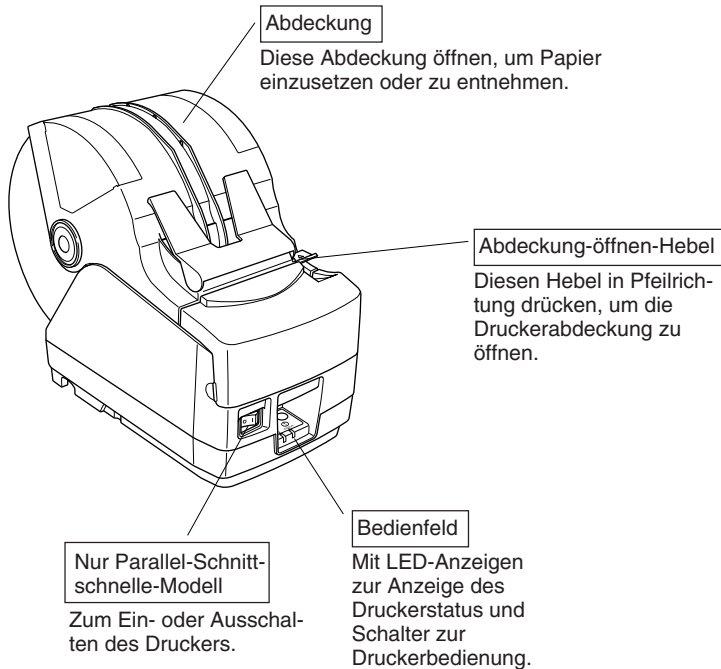

Wahl eines Aufstellungsorts für den Drucker

Bevor Sie den Drucker auspacken, sollten Sie einige Minuten damit verbringen, einen geeigneten Aufstellungsort auszusuchen. Denken Sie dabei an die folgenden Punkte:

- ✓ Den Drucker auf einem flachen, aber festen Untergrund aufstellen, wo keine Vibrationen vorhanden sind.
- ✓ Die verwendete Steckdose soll in der Nähe und frei zugänglich sein.
- ✓ Sicherstellen, daß der Drucker nahe genug am Computer ist, um die Geräte mit dem Druckerkabel verbinden zu können.
- ✓ Sicherstellen, daß der Drucker vor direktem Sonnenlicht geschützt ist.
- ✓ Sicherstellen, daß der Drucker ausreichend weit von Heizkörpern entfernt steht.
- ✓ Dafür sorgen, daß die Umgebung des Druckers sauber, trocken und staubfrei ist.
- ✓ Sicherstellen, daß der Drucker an eine einwandfreie Stromzufuhr angeschlossen ist. Er sollte nicht an Steckdosen angeschlossen werden, an denen bereits Geräte mit möglichen Netzstörungen wie Kopierer, Kühlschränke u.a. angeschlossen sind.
- ✓ Den Drucker nicht an Orten mit hoher Luftfeuchtigkeit aufstellen.

WARNUNG

- ✓ Das Gerät sofort ausschalten, wenn es Rauch, ungewöhnliche Geräusche und merkwürdige Geräusche abgibt. Sofort das Gerät vom Netz trennen und den Fachhändler benachrichtigen.
- ✓ Niemals versuchen, dieses Produkt selber zu reparieren. Unsachgemäße Reparaturen können gefährlich sein.
- ✓ Niemals dieses Produkt zerlegen oder modifizieren. Eingriffe an diesem Produkt können zu Verletzungen, Bränden oder elektrischen Schlägen führen.

3. Verbrauchsteile und Netzteil

Wenn die Verbrauchsteile verbraucht sind, besorgen Sie Ersatz entsprechend der unten gezeigten Tabelle.

Verwendung von Verbrauchsteilen oder Netzteilen, die nicht den unten aufgeführten Beschreibungen entsprechend, kann zu Schäden am Drucker, Bränden oder elektrischen Schlägen führen.

(1) Rollenpapierbeschreibung

Thermopapier

Dicke: 65 bis 150 μm

Breite: 44,5 \pm 0,5 bis 82,5 \pm 0,5 mm

Rollen-Außendurchmesser

: Max. ϕ 180 mm

(Bei Gebrauch von Drop-In-Rollenpapierwechsel)

: Max. ϕ 170 mm

(Bei Gebrauch der Rollenpapierwelle)

Breite der Aufnehmerpapierrolle: 45 $^{+0,5}_{-1}$ bis 83 $^{+0,5}_{-1}$ mm

Kern Außen/Innen-Durchmesser

| Papierstärke | Kern außen | Kern innen |
|-------------------------|---------------------------|-----------------------------|
| 65 – 100 μm | Max. ϕ 40 \pm 1 mm | Max. ϕ 25,4 \pm 1 mm |
| 100 – 150 μm | Max. ϕ 58 \pm 1 mm | Max. ϕ 50,8 \pm 1 mm |

Druckfläche: Äußere Papierkante

Behandlung der Papierendkante: Nicht Paste oder Kleber zum Befestigen von Papierrolle oder Kern verwenden.

Nicht die Papierendkante falten.

(2) Empfohlenes Papier

Mitsubishi Paper Mills Ltd.

T8037 (tickets), 85 μm (Dicke)

TF8067 (tickets), 84 μm (Dicke)

TF8075 (tickets), 85 μm (Dicke)

KANZAN

KLS46 (tickets)

KPO460 (tickets)

Kanzaki Specialty Papers Inc. (KSP)

Lotto482 (tickets), 84 μm (Dicke)

Je nach Typ und Stärke des Papiers kann es erforderlich sein, die Einstellungen für die Druckintensität zu ändern. Zum Ändern der Intensitätseinstellung den Druckintensität-Befehle <ESC><RS>'d'n oder Speicherschalter-Einstellungen verwenden. Einzelheiten siehe getrennte Spezifikationsanleitung.

(3) Netzteil (Option)

Modelbezeichnung: PS60

Eingang: 100 bis 240 V WS, 50/60 Hz

Ausgang: 24 V GS \pm 5%, max. 2,0 A (max. 10 s bei 5,0 A Last)

 **ACHTUNG**

Empfehlungen zu den zu verwendenden Papiersorten sind im Internet bei der folgenden URL erhältlich:

<http://www.star-m.jp/eng/dl/dl02.htm>

4. Anschlußkabel und Netzteil

4-1. Schnittstellenkabel

Beachten Sie, daß das Schnittstellenkabel nicht mitgeliefert ist. Bitte verwenden Sie ein Kabel, das den Spezifikationen entspricht.

⚠ ACHTUNG

Vor dem Anschließen/Abtrennen des Schnittstellenkabels stellen Sie sicher, daß der Drucker und alle angeschlossenen Gerät ausgeschaltet sind. Außerdem sollte der Netzstecker abgezogen sein.

4-1-1. Serielles Schnittstellenkabel (RS-232C)

- (1) Stellen Sie sicher, daß der Drucker ausgeschaltet ist.
- (2) Schließen Sie das Schnittstellenkabel an die Buchse an der Rückseite des Druckers an.
- (3) Befestigen Sie die Stecker-Schrauben.

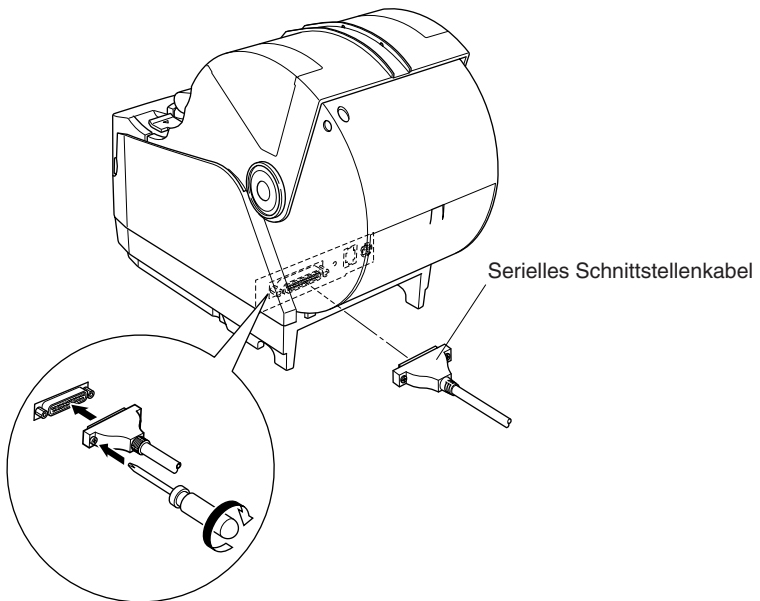

4-1-2. Parallele Schnittstelle

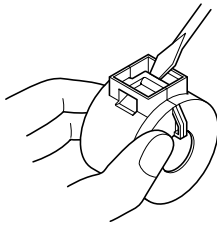

Ferritkern

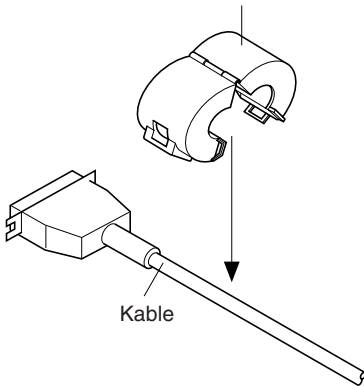

Kable

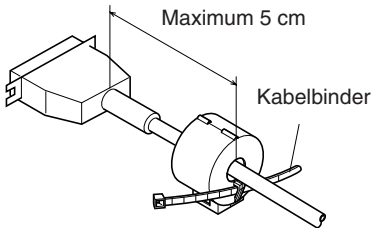

Maximum 5 cm

Kabelbinder

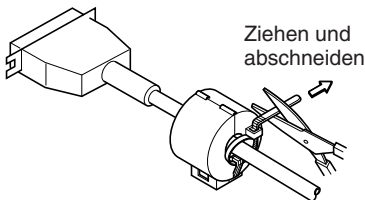

Ziehen und
abschneiden

- (1) Stellen Sie sicher, daß der Drucker ausgeschaltet ist.
- (2) Nur beim Parallel-Schnittschnelle-Modell, Befestigen Sie den großen Ferritkern am Kabel, wie das in der folgenden Abbildung gezeigt wird.

- (3) Führen Sie den Kabelbinder durch den Ferritkern.

- (4) Führen Sie den Kabelbinder um das Kabel und sperren Sie ihn. Schneiden Sie überschüssiges Band mit einer Schere ab.

- (5) Schließen Sie das Schnittstellenkabel an die Buchse an der Rückseite des Druckers an.
- (6) Befestigen Sie die Steckerklammern.

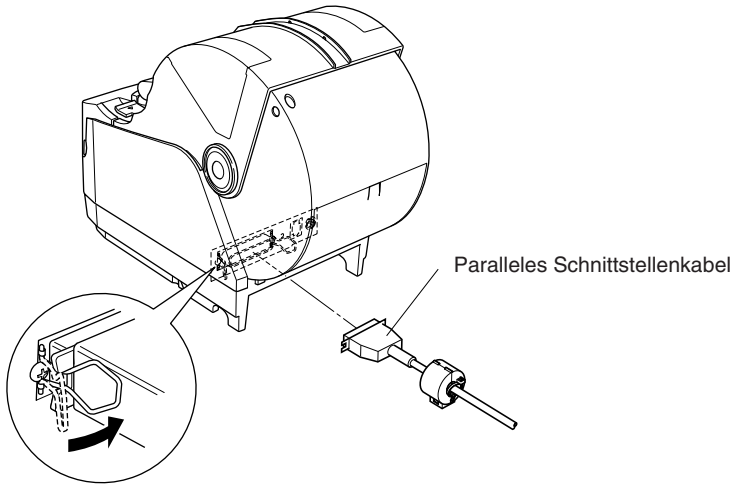

4-1-3. Anschließen des USB-Kabels

- (1) Stellen Sie sicher, daß der Drucker ausgeschaltet ist.
- (2) Bringen Sie den Ferritkern am USB-Kabel an, wie in der Abbildung unten gezeigt und stellen Sie sicher, das Kabel durch die Kabelhalterung zu führen, wie in der Abbildung gezeigt.

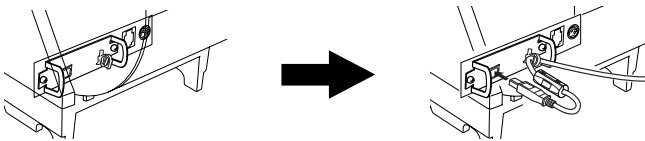

4-1-4. Anschließen des Ethernet-Kabels

- (1) Stellen Sie sicher, daß der Drucker ausgeschaltet ist.
- (2) Bringen Sie den Ferritkern auf dem Ethernet-Kabel an, wie in der Abbildung unten gezeigt.
- (3) Führen Sie die Befestigung durch den Ferritkern.
- (4) Führen Sie das Befestigungsteil um das Kabel und sperren es. Schneiden Sie überstehende Teile ab.
- (5) Schließen Sie das Ethernet-Kabel am Stecker an der Schnittstellenkarte an.
Dann verbinden Sie das andere Ende des Kabels mit Ihrem Computer.

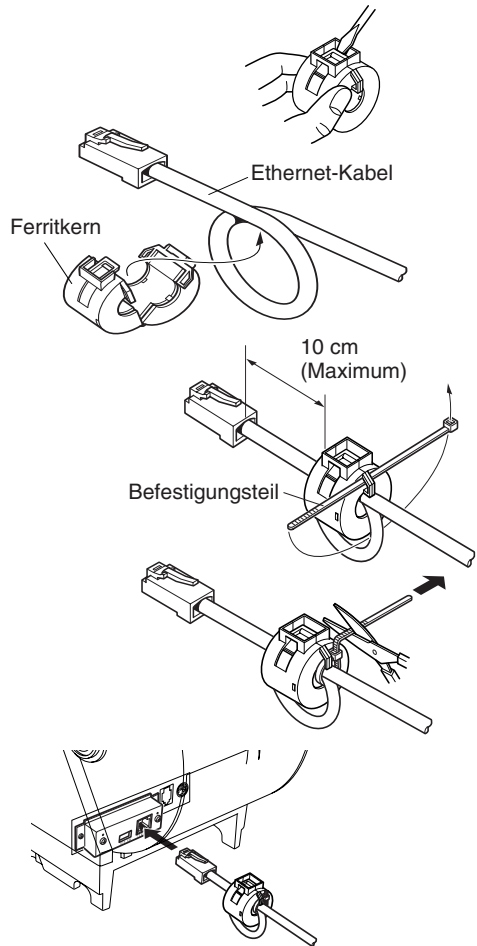

4-2. Anschließen an eine Signaltongebereinheit

Sie können eine Signaltongebereinheit mit einem Modularstecker an den Drucker anschließen. Im folgenden wird die Herstellung der Verbindung beschrieben. Siehe "Modularstecker" auf Seite 149 für den Typ von Modularstecker, der dazu erforderlich ist. Beachten Sie, daß der Drucker nicht mit einem Modularstecker oder Kabel ausgestattet ist. Diese Teile müssen vom Anwender besorgt werden.

⚠ ACHTUNG

Vor dem Anschließen der Kabel sicherstellen, daß der Drucker ausgeschaltet und vom Netz getrennt ist.

Schließen Sie das Signaltongebereinheit-Kabel am Stecker an der Rückseite des Druckers an.

⚠ ACHTUNG

Schließen Sie keine Telefonleitung am Signaltongebereinheit-Anschluß an. Wenn dies nicht beachtet wird, kann der Drucker beschädigt werden. Aus Sicherheitsgründen dürfen Sie auch nicht die Verdrahtung am Signaltongebereinheit-Anschluß anschließen, falls sie zu hohe Spannung führt.

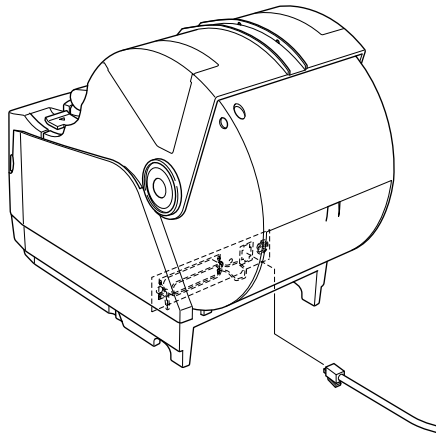

4-3. Anschließen des optionalen Netzteils

Hinweis: Vor dem Anschließen/Abtrennen des Netzteils stellen Sie sicher, daß der Drucker und alle angeschlossenen Gerät ausgeschaltet sind. Außerdem sollte der Netzstecker abgezogen sein.

(1) Schließen Sie das Netzteil an das Netzkabel an.

Hinweis: Verwenden Sie nur das vorgesehene Netzteil und Netzkabel.

(2) Das Netzteil am Stecker des Druckers anschließen.

(3) Stecken Sie den Netzstecker des Netzteils in eine Steckdose ein.

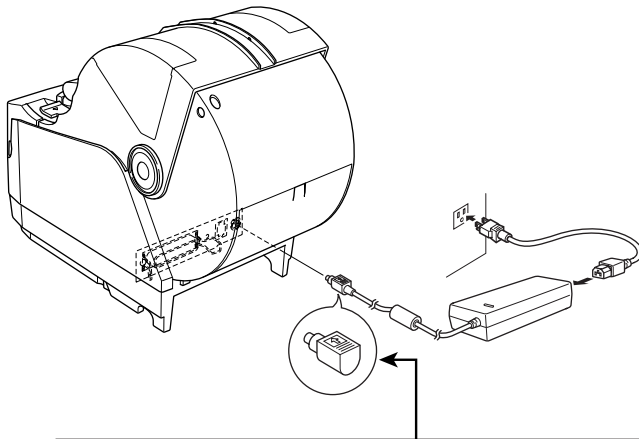

⚠ ACHTUNG

Beim Abziehen des Kabels immer am Stecker ziehen und nicht am Kabel. Durch das Lösen der Verriegelung wird das Abziehen des Steckers leicht möglich. Wenn stark am Kabel selber gezogen wird, kann der Stecker beschädigt werden.

4-4. Einschalten

Stellen Sie sicher, daß das Netzteil angeschlossen ist, wie in 4-3 beschrieben.

- (1) Den Netzschalter vorne am Gerät auf Ein (ON) stellen. Das POWER-Lämpchen am Bedienfeld leuchtet auf.

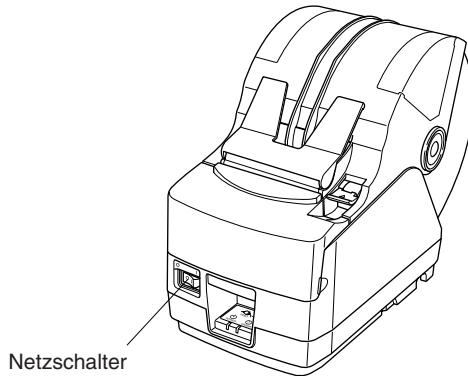

⚠ ACHTUNG

Wir empfehlen, den Netzstecker aus der Steckdose zu ziehen, wenn der Drucker längere Zeit lang nicht benutzt werden soll. Der Drucker sollte vorzugsweise an einem Platz aufgestellt werden, der leichten Zugang zur Netzsteckdose gewährt.

4-5. Installieren der Kabel

Installieren Sie die Kabel wie in den nachfolgenden Abbildungen dargestellt.

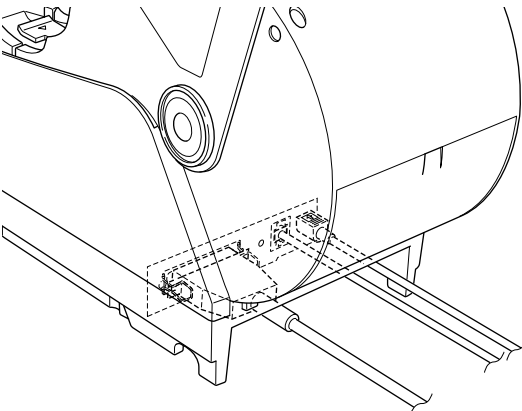
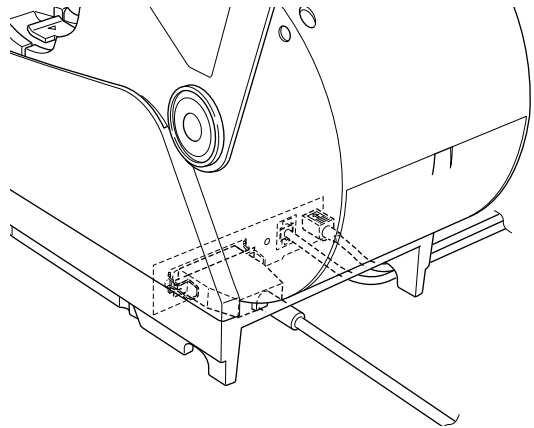
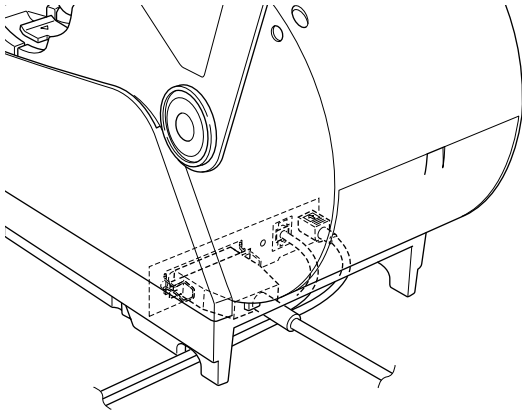

4-6. Einsetzen der Schalterabdeckung

Es ist nicht notwendig, die Schalterabdeckung zu verwenden. Setzen Sie diese nur ein, wenn für Sie erforderlich ist, daß

- der Netzschalter nicht versehentlich betätigt werden kann,
- der Netzschalter nicht mehr so einfach von anderen Personen betätigt werden kann.

Setzen Sie die Schalterabdeckung wie in den nachfolgenden Abbildungen dargestellt ein.

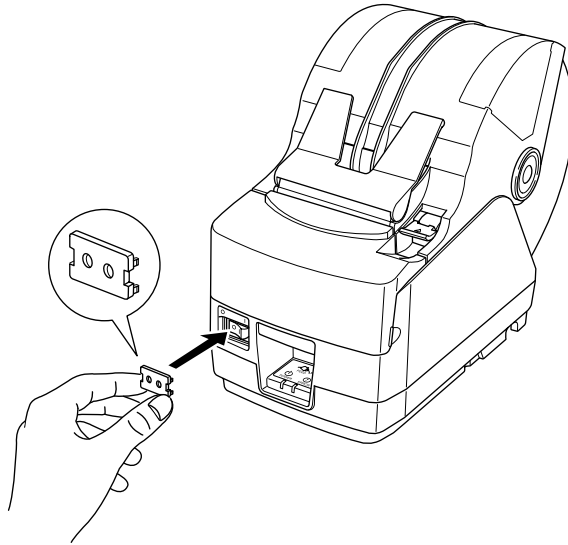

Der Netzschalter kann durch Einführen eines spitzen Gegenstandes (Kugelschreiber usw.) in die Aussparungen der Schalterabdeckung ein- (I) und ausgeschaltet (O) werden.

⚠ ACHTUNG

Wir empfehlen, den Netzstecker aus der Steckdose zu ziehen, wenn der Drucker längere Zeit lang nicht benutzt werden soll. Der Drucker sollte vorzugsweise an einem Platz aufgestellt werden, der leichten Zugang zur Netzsteckdose gewährt.

5. Bedienfeld und andere Funktionen

5-1. Bedienfeld

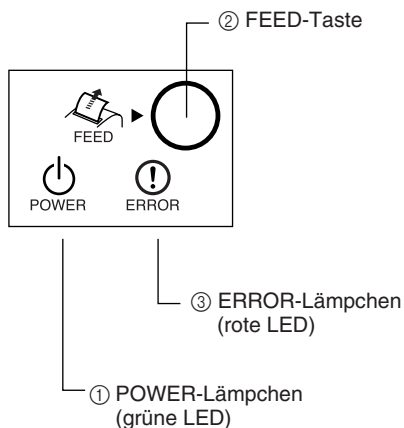

- ① POWER-Lämpchen (grüne LED)
Leuchtet in eingeschaltetem Zustand
- ② FEED-Taste
Die FEED-Taste drücken, um das Rollenpapier vorzutransportieren.
- ③ ERROR-Lämpchen (rote LED)
Zeigt in Kombination mit dem POWER-Lämpchen verschiedene Fehlerzustände an.

5-2. Fehler

1) Automatisch behebbare Fehler

| Fehlerbeschreibung | POWER-Lämpchen | ERROR-Lämpchen | Behebungsbedingungen |
|--------------------------------|-------------------------------|----------------|--|
| Erkennung hoher Kopftemperatur | Blinkt in Abständen von 0,5 s | Aus | Automatische Behebung nach Abkühlen des Druckkopfes. |
| Abdeckung-Offen-Fehler | Ein | Ein | Automatische Behebung nach Schließen der Druckerabdeckung. |

2) Behebbarer Fehler

| Fehlerbeschreibung | POWER-Lämpchen | ERROR-Lämpchen | Behebungsbedingungen |
|----------------------|----------------|-------------------------------|---|
| Papierschnitt-Fehler | Aus | Blinkt im Abstand von 0,125 s | Behoben, wenn das Schneidwerk nach dem Ein- und Ausschalten in Grundstellung zurückkehrt. |

Hinweis:

- 1) Wenn das Schneidwerk nicht in Grundstellung zurückkehrt oder nicht die Anfangsbewegung ausführt, ist Behebung nicht möglich.
- 2) Wenn Papierstau vorliegt, ausschalten, den Papierstau beheben, und dann wieder einschalten.

(3) Nicht behebbare Fehler

| Fehlerbeschreibung | POWER-Lämpchen | ERROR-Lämpchen | Behebungsbedingungen |
|------------------------|----------------|------------------------------|--|
| Papierschnitt-Fehler | Aus | Blinkt im Abstand von 1,0 s | Dies ist ein nicht behebbarer Fehler. Der Kundendienst muß bezüglich Reparatur kontaktiert werden. |
| EERROM-Fehler | Aus | Blinkt im Abstand von 0,75 s | Dies ist ein nicht behebbarer Fehler. Der Kundendienst muß bezüglich Reparatur kontaktiert werden. |
| Flash-ROM-Fehler | Aus | Blinkt im Abstand von 0,5 s | Dies ist ein nicht behebbarer Fehler. Der Kundendienst muß bezüglich Reparatur kontaktiert werden. |
| Thermistor-Fehler | Aus | Blinkt im Abstand von 1,5 s | Dies ist ein nicht behebbarer Fehler. Der Kundendienst muß bezüglich Reparatur kontaktiert werden. |
| Stromversorgung-Fehler | Aus | Blinkt im Abstand von 2 s | Dies ist ein nicht behebbarer Fehler. Der Kundendienst muß bezüglich Reparatur kontaktiert werden. |

Hinweis:

- 1) Wenn ein nicht behebbarer Fehler auftritt, das Gerät sofort ausschalten.
- 2) Wenn ein Stromversorgung-Fehler auftritt, besteht die Möglichkeit, daß die Netzversorgung nicht richtig ist.
Bei anderen nicht behebbaren Fehlern muß der Kundendienst bezüglich Reparatur kontaktiert werden.

(4) Papiererkennung-Fehler

| Fehlerbeschreibung | POWER-Lämpchen | ERROR-Lämpchen | Behebungsbedingungen |
|--------------------------------|----------------|-----------------------------|--|
| Papierschnitt-Fehler | Ein | Blinkt im Abstand von 0,5 s | Automatische Behebung durch Einlegen einer neuen Papierrolle und Schließen der Druckerabdeckung. |
| Papierrollenende fast erreicht | Ein | Blinkt im Abstand von 2 s | Die Anzeigen zeigen, daß das Ende der Papierrolle sich nähert, aber der Drucker druckt weiter. |

5-3. Selbstdruck

(1) Testdruck

Das Gerät einschalten, während die FEED-Taste gedrückt gehalten wird. Der Testdruck wird entsprechend der Ver. Nr., den DIP-Schalter-Einstellungen und den Speicherschalter-Einstellungen ausgeführt.

*** TSP1000 Ver1.00

Interface : Parallel

DIP Switch 1
Sw 12345678
On *****
Off

(2) Sedezimaler Datenausdruck

Die Druckerabdeckung öffnen, und dann einschalten, während die FEED-Taste gedrückt gehalten wird. Wenn die Abdeckung geschlossen wird, wird “***HEXDUMP PRINTING***” ausgedruckt, und der Drucker schaltet auf die Betriebsart sedezimaler Datenausdruck um.

Jedes der vom Computer zum Drucker gesandten Signale wird nun als sedezimaler Code ausgedruckt.

Diese Funktion erlaubt es, zu prüfen, ob ein von der Sowa zum Drucker gesandter Steuercode korrekt ist oder nicht. Die letzte Zeile wird nicht ausgedruckt, wenn Daten für weniger als eine ganze Zeile vorhanden sind. Wenn die FEED-Taste gedrückt wird, wird aber auch die letzte Zeile ausgedruckt. Zum Ausschalten dieser Betriebsart ist es erforderlich, den Drucker vollständig auszuschalten.

*** HEX DUMP PRINTING ***

| | |
|-------------------------|-------------|
| 20 21 22 23 24 25 26 27 | !"#\$%&' |
| 28 29 2A 2B 2C 2D 2E 2F | ()*+,-./ |
| 30 31 32 33 34 35 36 37 | 01234567 |
| 38 39 3A 3B 3C 3D 3E 3F | 89:;<=>? |
| 40 41 42 43 44 45 46 47 | @ABCDEFG |
| 48 49 4A 4B 4C 4D 4E 4F | HIJKLMNO |
| 50 51 52 53 54 55 56 57 | PQRSTUVWXYZ |

6. Einlegen der Papierrolle

6-1. Einlegen des Rollenpapiers

Das Einlegen des Rollenpapiers erfolgt je nach benutztem Papier (Drop-In-Rollenpapier oder Rollenpapier, für das die Welle erforderlich ist) unterschiedlich. Legen Sie das Rollenpapier gemäß den Verfahren in Abschnitt 6-2 ein.

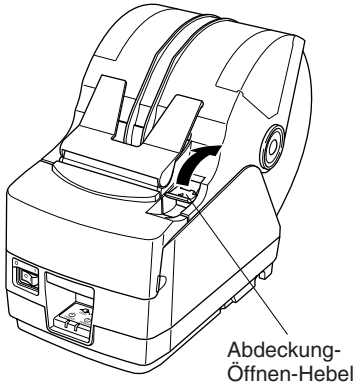

- (1) Den Abdeckung-Öffnen-Hebel drücken, und die Druckerabdeckung öffnen.
- (2) Unter Beachtung der richtigen Einsetzrichtung der Rolle die Papierrolle in die Vertiefung legen und die Vorderkante des Papiers nach vorne ziehen.

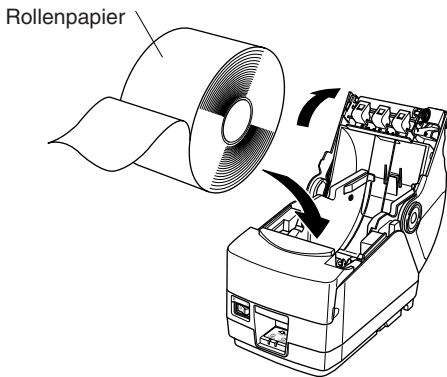

[Drop-In-Papierwechsel]

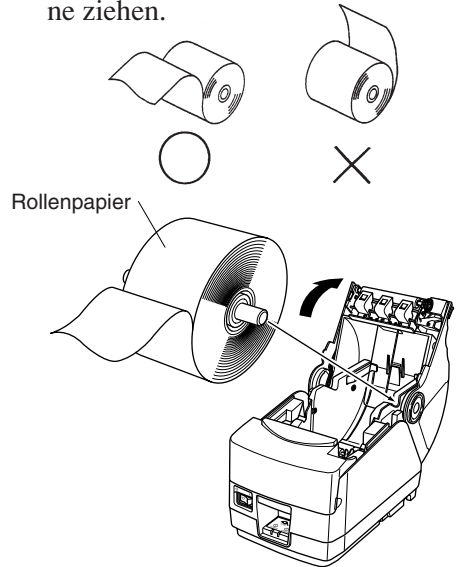

[Mit Welle]

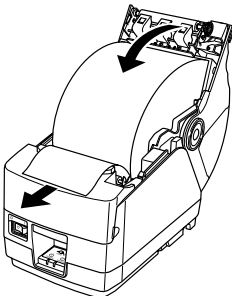

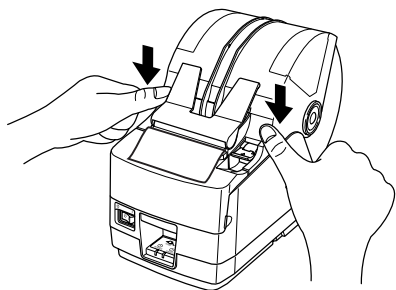

- (3) Ziehen Sie an der Papierkante, um Durchhang zu beseitigen und drücken Sie dann beide Seiten der Druckerabdeckung zum Schließen nach unten.

Hinweis: Sicherstellen, daß die Druckerabdeckung festgeschlossen ist.

- (4) Wenn die Druckerabdeckung nach dem Einschalten geschlossen wird, arbeitet das Schneidwerk automatisch, und das vordere Papierende wird abgeschnitten.

Hinweis: Wenn das Schneidwerk nach dem Schließen der Druckerabdeckung nicht arbeitet, öffnen Sie die Abdeckung und schließen sie wieder.

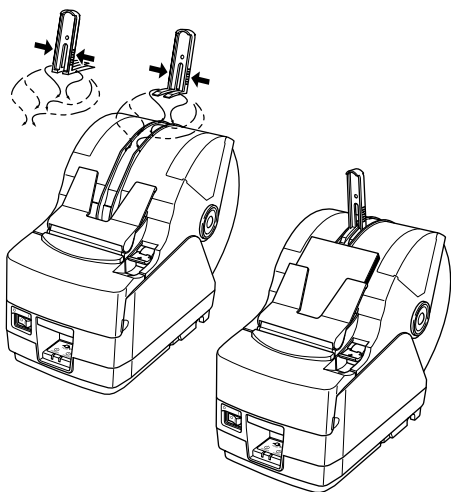

- (5) Wenn erforderlich bringen Sie den Papieranschlag an der Papierabdeckung wie gezeigt an. Das Ausgabefach kann bis zu 30 Blatt fassen (Breite: 80–82,5 mm, Dicke: 80–120 mm, Länge: 50–150 mm). Bei Papier mit anderer Stärke oder anderen Blattlängen höchstens 10 Blatt.

Hinweis: Beim Anbringen des Papieranschlags an der Papierabdeckung positionieren Sie den Anschlag entsprechend der Länge des abzuschneidenden Papiers. (Siehe folgende Tabelle.)

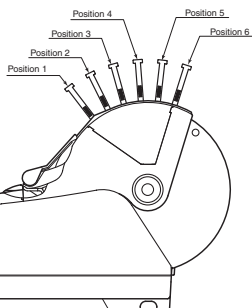

| | Papierlänge (mm) |
|------------|------------------|
| Position 1 | 50 – 100 |
| Position 2 | 100 – 120 |
| Position 3 | 120 – 140 |
| Position 4 | 140 – 160 |
| Position 5 | 160 – 180 |
| Position 6 | 180 – 200 |

⚠ WARNUNG

- *Nicht die Schneidwerkklinge berühren.*
 - *Im Papierauslaßschlitz befindet sich ein Schneidwerk. Niemals die Hände in den Auslaßschlitz stecken, nicht nur während des Druckbetriebs sondern auch wenn der Drucker nicht arbeitet.*
 - *Die Druckerabdeckung kann geöffnet werden, wenn das Papier ausgetauscht wird. Da das Schneidwerk im Inneren der Druckerabdeckung ist, darauf achten, nicht das Gesicht oder die Hände zu nahe an das Schneidwerkmesser zu bringen.*
 - *Während des Druckens und kurz nach dem Drucken kann der Bereich um den Thermalkopf sehr heiß werden. Nicht das Heizelement mit der Hand berühren.*
-

⚠ ACHTUNG

- *Nicht den Lösehebel der Abdeckung betätigen, während mit der Hand auf die Druckerabdeckung gedrückt wird.*
 - *Nicht das Papier bei geschlossener Druckerabdeckung herausziehen.*
 - *Das Heizelement und der Treiber-Chip des Thermalkopfes werden leicht beschädigt. Diese Teile nicht mit Metallgegenständen, Sandpapier usw. berühren.*
 - *Die Druckqualität kann nachlassen, wenn das Thermalkopf-Heizelement durch Berührung mit der Hand verschmutzt wird. Nicht das Thermalkopf-Heizelement berühren.*
 - *Es besteht die Gefahr von Schäden am Treiber-Chip durch statische Elektrizität. Niemals den Chip direkt berühren.*
 - *Die Druckqualität und die Lebensdauer des Thermalkopfes kann nicht garantiert werden, wenn anderes als Papier der vorgeschriebenen Sorte verwendet wird. Insbesondere Papier mit [Na+, K+, Cl-] kann die Lebensdauer des Thermalkopfes drastisch verkürzen. Bitte vorsichtig arbeiten.*
 - *Nicht den Drucker betreiben, wenn Feuchtigkeit durch Beschlag usw. an der Vorderseite des Druckkopfes vorhanden ist.*
-

6-2. Verfahren zum Papiereinlegen

Bei diesem Drucker gibt es zwei Verfahren zum Papiereinlegen: eins mit Rollenpapierwelle und eins ohne Welle. Die Rollenpapierwelle wird bei Drop-In-Papierwechsel nicht benutzt. Wählen Sie das Papiereinlegeverfahren aus folgender Tabelle je nach benutztem Papier.

| Papierbreite (mm) Papierstärke (μm) | $44,5 \leq \text{Breite} < 79,5$ | $79,5 \leq \text{Breite} \leq 82,5$ |
|---|-------------------------------------|-------------------------------------|
| $65 \leq \text{Stärke} < 80$ | Rollenpapierwelle benutzen (*1, *4) | Rollenpapierwelle benutzen (*2) |
| $80 \leq \text{Stärke} \leq 120$ | Rollenpapierwelle benutzen (*1, *4) | Drop-In-Papierwechsel benutzen (*3) |
| $120 < \text{Stärke} \leq 150$ | Rollenpapierwelle benutzen (*1) | Rollenpapierwelle benutzen (*1) |

Hinweis:

- *1: Maximaler Rollen-Außendurchmesser: 150 mm
- *2: Maximaler Rollen-Außendurchmesser: 170 mm
- *3: Maximaler Rollen-Außendurchmesser: 180 mm
- *4: Die Druckgeschwindigkeit muß von hoher Geschwindigkeit (Werkseinstellung) auf mittlere Geschwindigkeit (140 mm/s) herabgesetzt werden. Zum Ändern der Druckgeschwindigkeit den Druckgeschwindigkeits-Befehl <ESC><RS> Rn verwenden. Einzelheiten siehe getrennte Spezifikationsanleitung.

6-4. Einstellen der Papierführung

Bei Lieferung sind die Papierführungen und oberen Führungen für Rollenpapier mit folgender Breite eingestellt.

Papierbreite: $79,5 \pm 0,5$ mm (TSP1043)

Papierbreite: $82,5 \pm 0,5$ mm (TSP1045)

Wenn Sie Rollenpapier mit einer anderen Breite als oben angegeben verwenden, führen Sie folgendes Verfahren aus, um die Papierführungen einzustellen. Zum Einstellen der oberen Führungen, siehe “6-5 Einstellen der oberen Führungen”.

- (1) Die vier Schrauben lösen.
- (2) Die linke und rechte Papierführung je nach Breite des Rollenpapiers einstellen. Achten Sie dabei darauf, 0,5 mm Abstand zwischen den Führungen und der Papierkante zu lassen.

Die Skalen auf der Metallplatte im Drucker sind in 1 mm-Abschnitte zwischen den \blacklozenge Markierungen unterteilt. Die beiden \blacktriangledown Markierungen oberhalb der Skalen werden für 57,5 mm breites Papier und die beiden \blacklozenge Markierungen für 79,5 mm breites Papier verwendet. Setzen Sie bei 79,5 mm breitem Rollenpapier jede Papierführung daher 0,5 mm von der entsprechenden \blacklozenge Markierung entfernt nach außen. Die Schrauben 2 und 3 können gegebenenfalls gelöst und in die daneben liegenden Schraubenlöcher eingesetzt werden.

- (3) Die vier Schrauben festziehen.

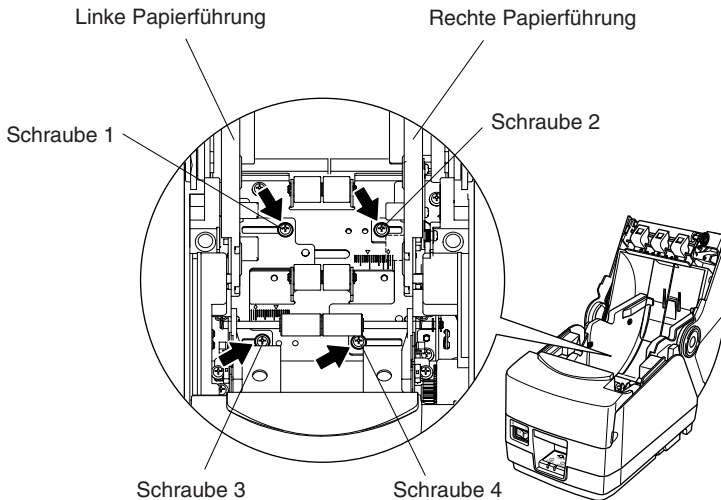

6-5. Einstellen der oberen Führung

Bei Lieferung sind die oberen Führungen für Rollenpapier mit einer Breite von 79,5–82,5 mm eingestellt. Wenn Sie Rollenpapier mit einer anderen Breite verwenden möchten, führen Sie folgendes Verfahren aus, um die oberen Führungen einzustellen.

- (1) Die beiden Schrauben für die linke und rechte obere Führung lösen.
- (2) Die linke und rechte obere Führung je nach Breite des Rollenpapiers einstellen. Achten Sie dabei darauf, daß jede Führung die Papierkante um etwa 2 mm überlappt.

Die Skalen auf der Metallplatte an der Abdeckung sind in 1 mm-Abschnitte unterteilt. Die beiden ▲ Markierungen unterhalb der Skalen werden für 57,5 mm breites Papier und die beiden ◆ Markierungen für 79,5 mm breites Papier (auch bei 82,5 mm breitem Papier) verwendet.

Die Schrauben für die linke und rechte obere Führung können gegebenenfalls gelöst und in die daneben liegenden Schraubenlöcher eingesetzt werden. Wenn die Rollenpapierbreite 50 mm oder weniger beträgt, die mittlere obere Führung ausbauen, indem Sie die Schraube lösen, und dann die linke und rechte obere Führung einstellen.

Hinweis:

Vermeiden Sie beim Einstellen der oberen Führungen, die Kabel einzuklemmen oder zu quetschen.

- (3) Die zwei Schrauben festziehen.

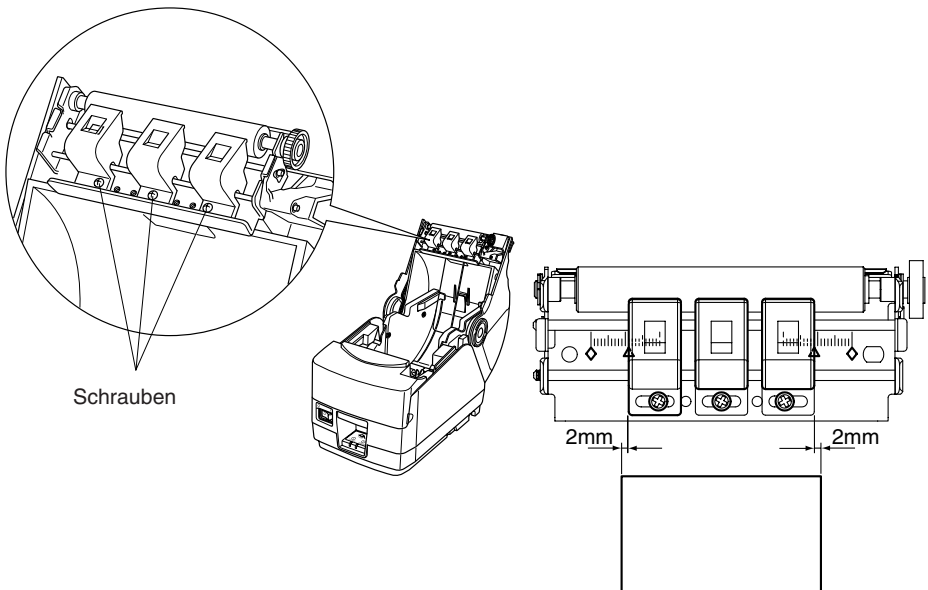

7. Einstellung des Endanherungs-Sensors

Den Endanherungs-Sensor auf folgende Weise justieren, damit er der Größe der verwendeten Papierrolle entspricht.

- ① Die Druckerabdeckung öffnen.
- ② Bestimmen Sie die korrekte Position des Einstellers unter den folgenden drei Positionen je nach Papiereinlegeverfahren und Kern-Innendurchmesser des Rollenpapiers.
 Position 1: Bei Drop-In-Papierwechsel
 Position 2: Bei Rollenpapierhalter 2 (ø50,8 mm Kern innen)
 Position 3: Bei Rollenpapierhalter 1 (ø25,4 mm Kern innen)
- ③ Die Spitze eines Kugelschreibers o.ä. Gegenstands in das Loch des Einstellers stecken, und dann eindrücken und den Einsteller auf die gewünschte Einstellung schieben.

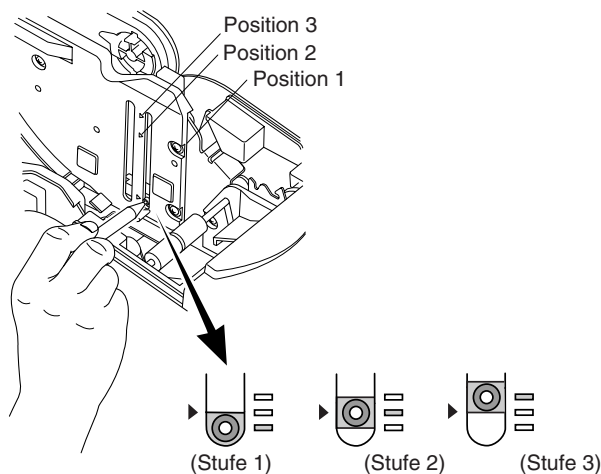

Die Restmenge von Papier, das erkannt wird, ist in nachfolgender Tabelle aufgeführt.

(1) Position 1

| Papierdicke (μm) | Bei Gebrauch von Rollenpapier mit einem Kern-Innendurchmesser (A): ø25,4 und Kern-Außendurchmesser (B): ø40 | | | | | |
|----------------------------------|---|---------|---------|-----------------------------|---------|---------|
| | Erkannter Durchmesser (C) (Etwa mm) | | | Restpapierlänge (Etwa m) | | |
| | Stufe 1 | Stufe 2 | Stufe 3 | Stufe 1 | Stufe 2 | Stufe 3 |
| 80 | ø44 | ø48 | ø52 | 3,5 | 7,5 | 12,5 |
| 105 | | | | 1,5 | 4,5 | 7,5 |

(2) Position 2

| Papierdicke (μm) | Bei Gebrauch von Rollenpapier mit einem Kern-Innendurchmesser (A): $\phi 25,4$ und Kern-Außendurchmesser (B): $\phi 40$ | | | | | |
|----------------------------------|---|-----------|---------|-----------------------------|---------|---------|
| | Erkannter Durchmesser (C) (Etwa mm) | | | Restpapierlänge (Etwa m) | | |
| | Stufe 1 | Stufe 2 | Stufe 3 | Stufe 1 | Stufe 2 | Stufe 3 |
| 65 | — | $\phi 45$ | — | — | 5,6 | — |
| 80 | | | | | 4,4 | |
| 105 | | | | | 3,2 | |

(3) Position 3

| Papierdicke (μm) | Bei Gebrauch von Rollenpapier mit einem Kern-Innendurchmesser (A): $\phi 50,8$ und Kern-Außendurchmesser (B): $\phi 58$ | | | | | |
|----------------------------------|---|-----------|---------|-----------------------------|---------|---------|
| | Erkannter Durchmesser (C) (Etwa mm) | | | Restpapierlänge (Etwa m) | | |
| | Stufe 1 | Stufe 2 | Stufe 3 | Stufe 1 | Stufe 2 | Stufe 3 |
| 150 | — | $\phi 69$ | — | — | 6,5 | — |

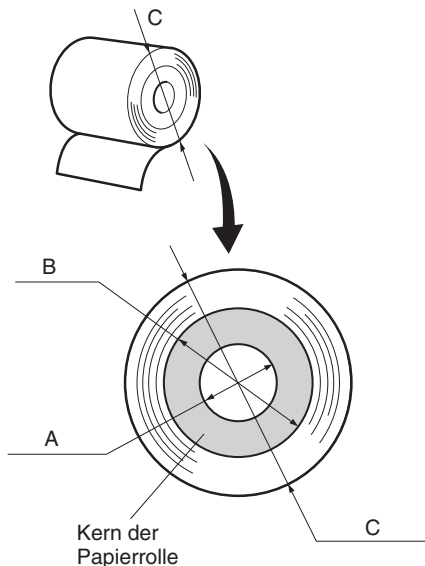

Hinweis:

- 1) Vor der Lieferung wird der Einsteller auf Position 1, Level 2 eingestellt.
- 2) Die Abmessung C und die restliche Papierlänge sind berechnete Werte. Es können leichte Abweichungen zum tatsächlichen Wert auftreten.
- 3) Die restlichen in der Tabelle oben gezeigten Papierlängen dienen nur zur Orientierung. Stellen Sie den Papierende-Sensor entsprechend den aktuellen Verwendungsbedingungen ein.
- 4) Wird starkes Papier (100 μm oder stärker) verwendet, wenn der Einsteller auf position 1 gesetzt ist, sitzt das Rollenpapier lose und es kann leichter zu Erkennungsfehlern kommen. Auf Stufe 3 stellen.

8. Verhindern und Beheben von Papierstau

8-1. Verhindern von Papierstau

Das Papier soll beim Ausgeben und vor dem Schneiden nicht berührt werden. Wenn das Papier beim Ausgeben gedrückt oder gezogen wird, kann ein Papierstau, ein Abschneidfehler oder ein Zeilenvorschubfehler verursacht werden.

8-2. Beheben von Papierstau

Wenn ein Papierstau auftritt, beheben Sie ihn wie folgt.

- (1) Stellen Sie den Netzschalter auf Aus, um den Drucker auszuschalten.
- (2) Drücken Sie den Abdeckung-Öffnen-Hebel, und öffnen Sie die Druckerabdeckung.
Wenn die Druckerabdeckung sich bei Modellen mit automatischer Abschneideinheit nicht öffnet, bedeutet dies, daß die automatische Abschneideinheit nicht in Grundstellung ist. In diesem Fall die automatische Abschneideinheit entsprechend den in Abschnitt 8-3 gegebenen Anweisungen auf Grundstellung zurückstellen. Dann die Druckerabdeckung öffnen, nachdem der Papierstau behoben ist.
- (3) Entfernen Sie das gestaute Papier.

ACHTUNG

Achten Sie darauf, den Drucker beim Entfernen des gestauten Papiers nicht zu beschädigen. Insbesondere der Thermaldruckkopf läßt sich leicht beschädigen; achten Sie darauf, ihn nicht zu berühren.

- (4) Stellen Sie sicher, daß das Papier gerade ausgerichtet ist, und schließen Sie die Druckerabdeckung vorsichtig.
Hinweis:
 - 1) Stellen Sie sicher, daß das Papier gerade ausgerichtet ist. Wenn die Druckerabdeckung bei schief liegendem Papier geschlossen wird, kann ein Papierstau auftreten.
 - 2) Sperren Sie die Druckerabdeckung durch Drücken auf beide Seiten. Sicherstellen, daß die Abdeckung richtig geschlossen ist.
- (5) Stellen Sie den Netzschalter in Ein-Stellung, um den Drucker einzuschalten. Stellen Sie sicher, daß die ERROR-LED nicht leuchtet.
Hinweis: Während die ERROR-LED leuchtet, akzeptiert der Drucker keine Befehle wie Druckbefehl; stellen Sie deshalb sicher, daß die Abdeckung richtig geschlossen ist.

8-3. Freigeben eines gesperrten Schneidmessers

Wenn das automatische Schneidmesser sperrt oder das Papier nicht schneidet, wie folgt verfahren.

⚠ WARNUNG

Da Arbeiten am Schneidmesser gefährlich sein können, immer zuerst den Drucker ausschalten.

- (1) Den Netzschalter auf Aus (OFF) stellen, um den Drucker auszuschalten.
- (2) Die Frontabdeckung abschieben, um das Schneidmesser freizulegen.
- (3) Gestautes Papier entfernen.

⚠ ACHTUNG

*Darauf achten, nicht den Drucker nicht beim Entfernen von gestautem Papier zu beschädigen.
Da der Thermalkopf besonders empfindlich ist, darauf achten, ihn nicht zu berühren.*

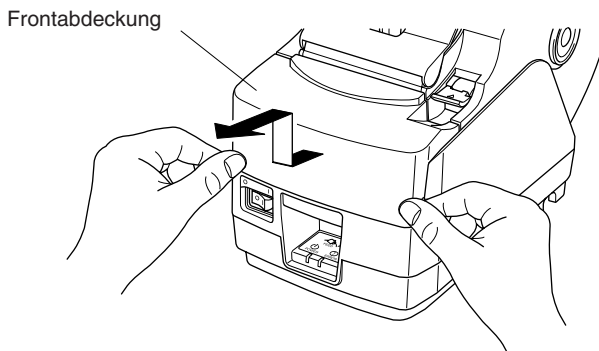

- (4) Wenn die bewegliche Klinge des Schneidmessers hervorsteht, den Knopf in Pfeilrichtung drehen, und die bewegliche Klinge in Grundstellung zurückstellen. Wenn das Prüfenster vollständig weiß ist, ist die bewegliche Klinge in Grundstellung.

⚠ ACHTUNG

- 1) Nicht starken Druck auf die bewegliche Klinge ausüben.
 - 2) Wenn die bewegliche Klinge zu sehr hervorsteht, kann die Druckerabdeckung nicht geöffnet werden. Wenn versucht wird, die Abdeckung zu öffnen, kann das Schneidmesser beschädigt werden.
-

- (5) Die Druckerabdeckung öffnen, gestautes Papier entfernen, und dann die Papierrolle wieder einsetzen.
- (6) Die Frontabdeckung wieder einsetzen, und den Netzschalter auch Ein (ON) stellen.

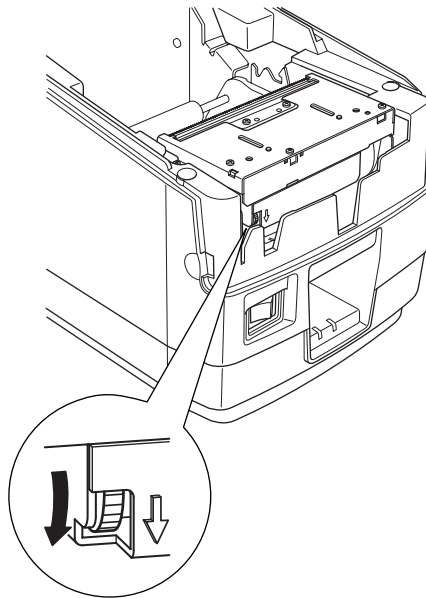

9. Regelmäßige Reinigung

Die Druckzeichen können durch Ansammlung von Papierstaub und anderem Schmutz unscharf werden. Um das zu verhindern, muß im Papierhalter und in der Papiertransportstufe angesammelter Staub von Zeit zu Zeit entfernt werden. Diese Reinigung sollte einmal alle sechs Monate oder einmal nach jeder Million Zeilen ausgeführt werden.

9-1. Reinigen des Thermalkopfes

Zum Entfernen von schwärzlichem Staub auf der Oberfläche des Thermalkopfes diesen mit Isopropylalkohol (IPA) abwischen.

Hinweis: Der Thermalkopf läßt sich leicht beschädigen. Zum Abwischen immer einen sehr weichen Lappen verwenden und sicherstellen, daß er nicht zerkratzt wird.

9-2. Reinigen des Papierhalters

Verwenden Sie einen weichen Lappen zur Entfernung von Papierstaub vom Papierhalter und aus der Papiertransportstufe.

INDICE

| | |
|--|------------|
| 1. Disimballaggio e installazione | 97 |
| 1-1. Disimballaggio | 97 |
| 2. Identificazione delle parti e nomenclatura | 98 |
| 3. Parti soggette a consumo e trasformatore CA | 100 |
| 4. Cavi di collegamento e trasformatore CA | 102 |
| 4-1. Cavo interfaccia | 102 |
| 4-2. Collegamento ad un'unità cicalino | 106 |
| 4-3. Collegamento del trasformatore CA opzionale | 107 |
| 4-4. Accensione | 108 |
| 4-5. Installazione del cavo | 109 |
| 4-6. Installazione mascherina dell'interruttore | 110 |
| 5. Pannello di controllo e altre funzioni | 111 |
| 5-1. Pannello di controllo | 111 |
| 5-2. Errori | 111 |
| 5-3. Stampa automatica | 113 |
| 6. Inserimento del rotolo di carta | 114 |
| 6-1. Inserimento del rotolo di carta | 114 |
| 6-2. Metodi di inserimento carta | 117 |
| 6-3. Regolazione dei fermi del rotolo di carta | 118 |
| 6-4. Regolazione delle guide della carta | 119 |
| 6-5. Regolazione delle guide superiori | 120 |
| 7. Regolazione del sensore di esaurimento prossimo | 121 |
| 8. Prevenzione e soluzione degli inceppamenti della carta | 123 |
| 8-1. Prevenzione degli inceppamenti della carta | 123 |
| 8-2. Eliminazione degli inceppamenti della carta | 123 |
| 8-3. Rilascio della taglierina bloccata | 124 |
| 9. Pulizia periodica | 126 |
| 9-1. Pulizia della testina termica | 126 |
| 9-2. Pulizia del comparto carta | 126 |
| APPENDICE | 128 |

L'Appendice appare solo nella sezione in inglese di questo manuale.

Visitare il seguente indirizzo URL

<http://www.star-m.jp/eng/dl/dl02.htm>

per accedere alla versione più recente del manuale.

1. Disimballaggio e installazione

1-1. Disimballaggio

Dopo aver disimballato l'unità, controllare che tutti gli accessori necessari siano inclusi nella confezione.

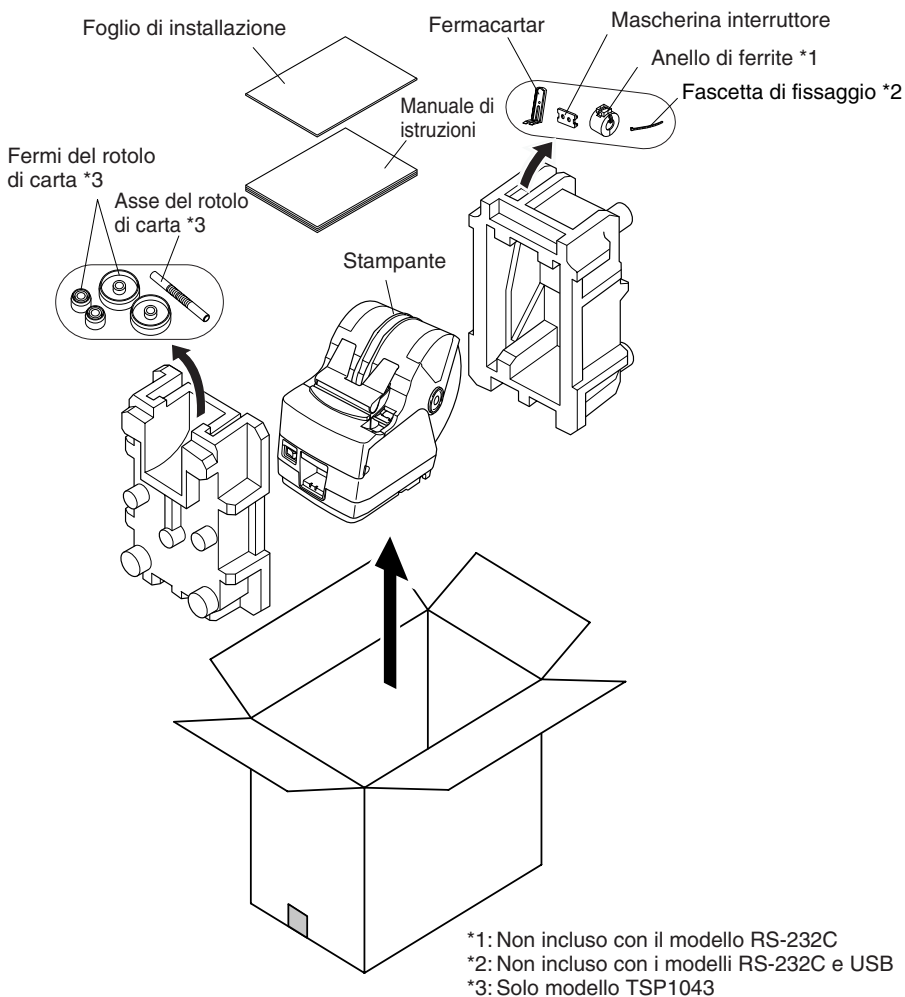
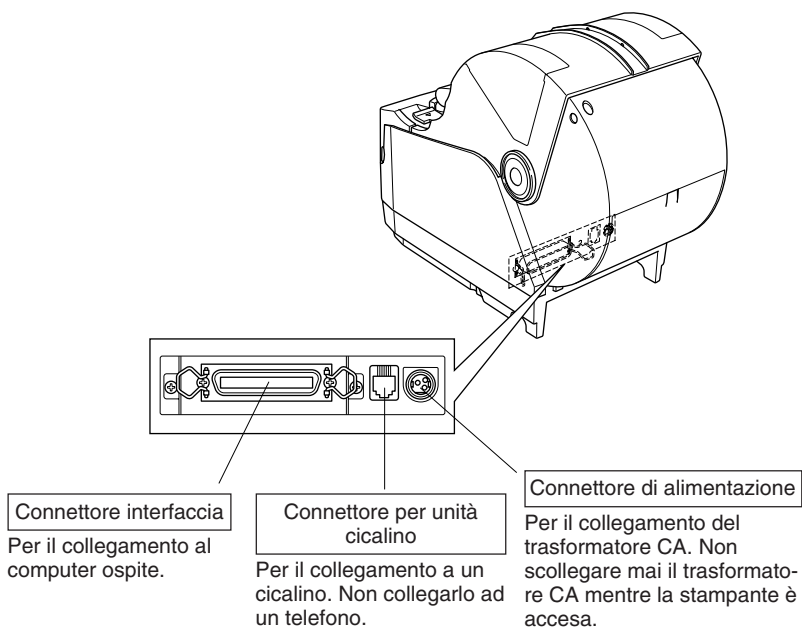
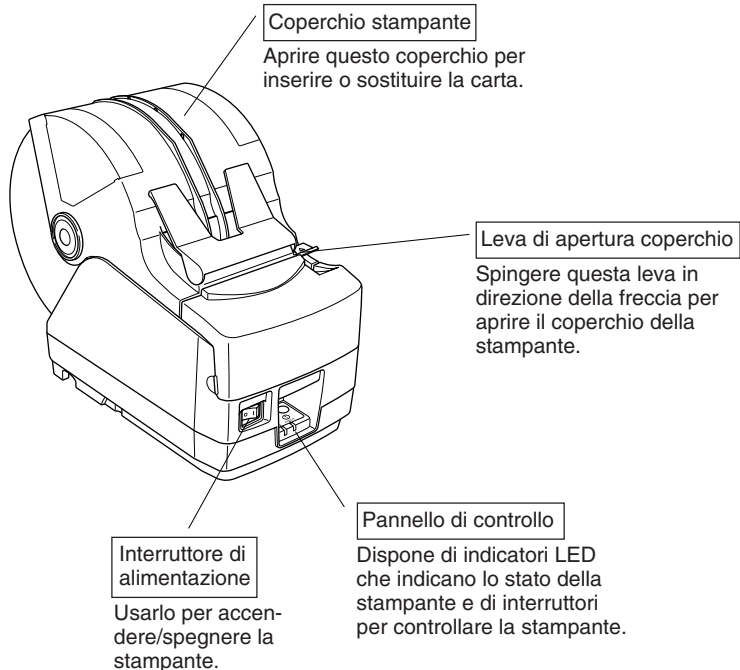

Fig. 1-1 Disimballaggio

Se dovesse mancare qualcosa, contattare il concessionario da cui si è acquistata la stampante e richiedere la parte mancante. Notare che è consigliabile conservare lo scatolone originale e tutti i materiali di imballaggio in caso si debba reimballare e spedire la stampante in futuro.

2. Identificazione delle parti e nomenclatura



Scelta di un luogo per la stampante

Prima di disimballare la stampante, decidere dove si desidera installarla. Tenere presenti i seguenti punti.

- ✓ Scegliere una superficie stabile e in piano, dove la stampante non sia esposta a vibrazioni.
- ✓ La presa di corrente che si intende usare per la stampante deve essere vicina e libera da ostacoli.
- ✓ La stampante deve essere abbastanza vicina al computer da permettere il collegamento tra i due.
- ✓ Assicurarsi che la stampante non sia esposta alla luce solare diretta.
- ✓ Assicurarsi che la stampante sia lontana da caloriferi e altre fonti di calore elevato.
- ✓ Assicurarsi che l'area circostante sia pulita, asciutta e priva di polvere.
- ✓ Assicurarsi che la stampante sia collegata ad una presa di corrente affidabile. Non deve essere la stessa presa di corrente di copiatrici, frigoriferi e altre apparecchiature che causano picchi di corrente.
- ✓ Assicurarsi che la stanza dove si usa la stampante non sia troppo umida.

ATTENZIONE

- ✓ Spegnerne immediatamente l'apparecchio se emette fumo, odori strani o rumori insoliti. Scollegare immediatamente l'apparecchio dalla presa di corrente e consultare il rivenditore.
- ✓ Non tentare mai di riparare personalmente il prodotto. Riparazioni eseguite in modo improprio possono essere pericolose.
- ✓ Non smontare o modificare mai questo prodotto. Alterazioni di questo prodotto possono causare lesioni, incendi o scosse elettriche.

3. Parti soggette a consumo e trasformatore CA

Quando le parti soggette a consumo si sono esaurite, usare quelle specificate nella seguente tabella. Assicurarsi di usare il trasformatore CA specificato nella tabella. L'uso di parti soggette a consumo o di un trasformatore CA diversi da quanto specificato nella tabella può causare danni alla stampante, incendi o scosse elettriche.

(1) Carta in rotolo specifiche

Carta termica

Spessore: 65 a 150 μm

Larghezza: 44,5 \pm 0,5 a 82,5 \pm 0,5 mm

Diametro esterno rullo:

Mass. ϕ 180 mm

(quando il rotolo di carta viene inserito direttamente)

Mass. ϕ 170 mm

(quando si utilizza l'asse del rotolo carta)

Larghezza carta del rullo di raccolta: 45 $^{+0,5}$ $_{-1}$ a 83 $^{+0,5}$ $_{-1}$ mm

Diametro interno/esterno nucleo

| Spessore carta | Nucleo: esterno | Nucleo: interno |
|-------------------------|---------------------------|-----------------------------|
| 65 – 100 μm | Mass ϕ 40 \pm 1 mm | Mass ϕ 25,4 \pm 1 mm |
| 100 – 150 μm | Mass ϕ 58 \pm 1 mm | Mass ϕ 50,8 \pm 1 mm |

Superficie stampata: Bordo esterno del rotolo

Maneggio dell'estremità finale: Non usare colla o adesivi per fissare la carta del rotolo o il suo nucleo.

Non piegare l'estremità finale della carta.

(2) Carta consigliata

Mitsubishi Paper Mills Limited

T8037 (biglietti scheda), 85 μm (spessore)

TF8067 (biglietti scheda), 84 μm (spessore)

TF8075 (biglietti scheda), 85 μm (spessore)

KANZAN

KLS46 (biglietti scheda)

KPO460 (biglietti scheda)

Kanzaki Specialty Papers Inc. (KSP)

Lotto482 (biglietti scheda), 84 μm (spessore)

A seconda del tipo e dello spessore della carta, può essere necessario cambiare le impostazioni per la densità di stampa. Per cambiare le impostazioni di densità, usare il comando di impostazione densità di stampa <ESC><RS>'d'n o le impostazioni dell'interruttore memoria. Fare riferimento al Manuale specifiche separato per dettagli.

(3) Trasformatore CA (opzionale)

Nome modello: PS60

Ingresso: Da 100 a 240 V CA, 50/60 Hz

Uscita: $24 \pm 5\% \text{CC}$, 2,0 A (5,0 A carico 10 sec. mass.)

 **CAUTELA**

Accedere alla seguente URL per informazioni sulla carta consigliata.
<http://www.star-m.jp/eng/dl/dl02.htm>

4. Cavi di collegamento e trasformatore CA

4-1. Cavo interfaccia

Notare che il cavo interfaccia non è in dotazione. Si prega di usare un cavo che corrisponde alle specifiche.

⚠ CAUTELA

Prima di collegare/scollegare il cavo interfaccia, assicurarsi che la stampante e tutti i dispositivi collegati alla stampante siano spenti. Inoltre assicurarsi che la spina del cavo di alimentazione sia scollegata dalla presa di corrente.

4-1-1. Cavo interfaccia seriale (RS-232C)

- (1) Assicurarsi che la stampante sia spenta.
- (2) Collegare il cavo interfaccia al connettore sul pannello posteriore della stampante.
- (3) Serrare le viti del connettore.

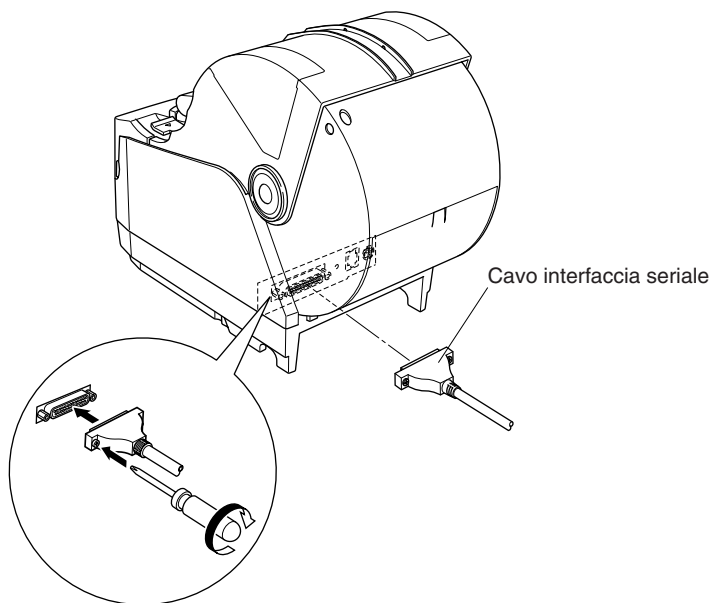

4-1-2. Interfaccia parallelo

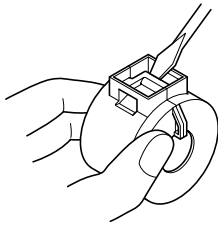

Anello di ferrite

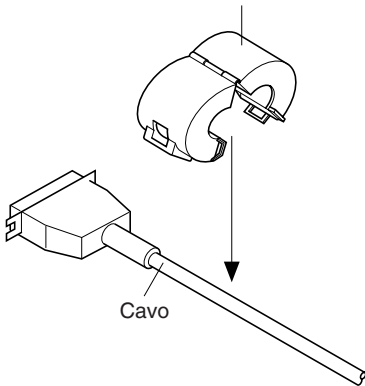

Cavo

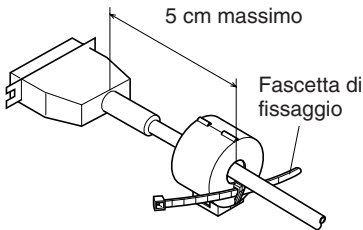

5 cm massimo

Fascetta di fissaggio

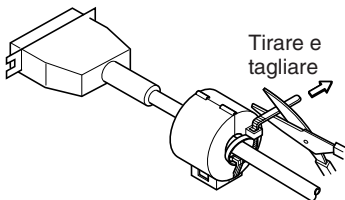

Tirare e tagliare

- (1) Assicurarsi che la stampante sia spenta.
- (2) Solo per il modello a interfaccia parallelo, fissare l'anello di ferrite al cavo come mostrato nell'illustrazione qui sotto.

- (3) Far passare la fascetta di fissaggio attraverso l'anello di ferrite.

- (4) Avvolgere la fascetta intorno al cavo e fissarla. Usare delle forbici per tagliare la parte in eccesso.

- (5) Collegare il cavo interfaccia al connettore sul pannello posteriore della stampante.
- (6) Fissare i morsetti del connettore.

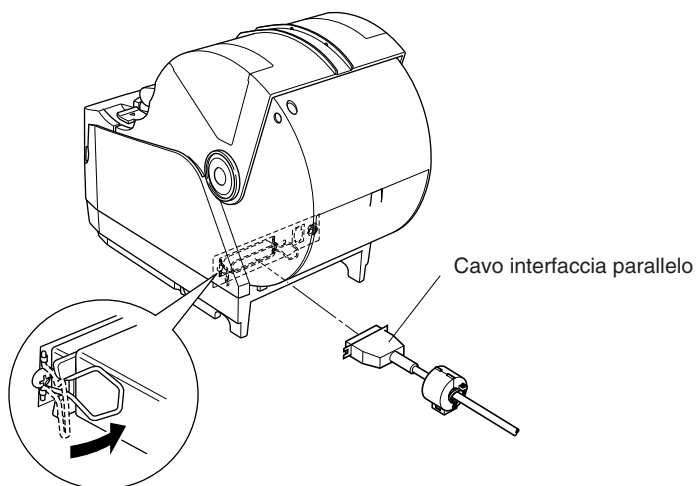

4-1-3. Collegamento del cavo USB

- (1) Assicurarsi che la stampante sia spenta.
- (2) Applicare l'anello di ferrite al cavo USB come mostrato nell'illustrazione sotto e assicurarsi di far passare il cavo attraverso il fermacavo come mostrato nell'illustrazione.

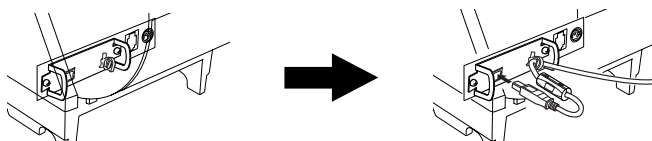

4-1-4. Collegamento del cavo Ethernet

- (1) Assicurarsi che la stampante sia spenta.
- (2) Applicare l'anello di ferrite al cavo Ethernet come mostrato nell'illustrazione sotto.
- (3) Far passare il fermo attraverso l'anello di ferrite.
- (4) Far passare il fermo intorno al cavo e bloccarlo. Usare delle forbici per tagliare la parte in eccesso.
- (5) Collegare il cavo Ethernet al connettore sulla scheda interfaccia. Poi collegare l'altro capo del cavo al computer.

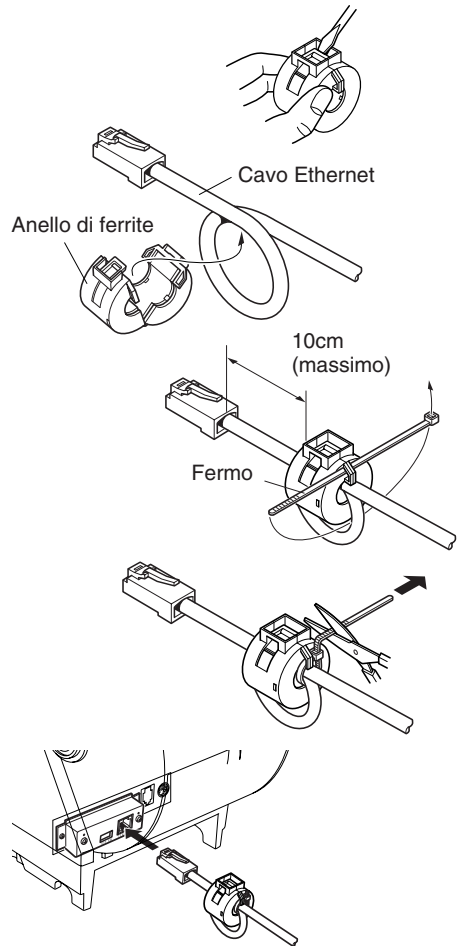

4-2. Collegamento ad un'unità cicalino

Si può collegare un'unità cicalino alla stampante usando una spina modulare. Di seguito descriviamo come eseguire il collegamento. Vedere “Modulare necessario” a pagina 149 per dettagli sul tipo di spina modulare necessario. Notare che la stampante non è dotata di spina o filo modulare, che devono essere acquistati in base alle esigenze di impiego.

⚠ CAUTELA

Assicurarsi che la stampante sia spenta e scollegata dalla presa di corrente e che il computer sia spento prima di eseguire il collegamento.

Collegare il cavo dell'unità cicalino al connettore sul pannello posteriore della stampante.

⚠ CAUTELA

Non collegare una linea telefonica al connettore per unità cicalino. Se non si osserva questa precauzione, si potrebbe danneggiare la stampante.

Inoltre, per sicurezza, non collegare fili al connettore per unità cicalino se esiste la possibilità che possano avere una tensione eccessiva.

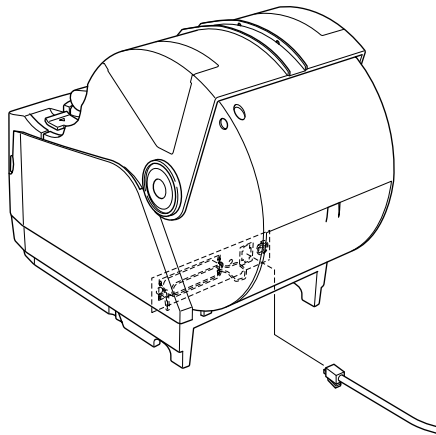

4-3. Collegamento del trasformatore CA opzionale

Nota: Prima di collegare/scollegare il trasformatore CA, assicurarsi che la stampante e tutti i dispositivi collegati alla stampante siano spenti. Inoltre assicurarsi che la spina del cavo di alimentazione sia scollegata dalla presa di corrente.

(1) Collegare il trasformatore CA al cavo di alimentazione.

Nota: Usare solo il trasformatore CA e cavo di alimentazione standard.

(2) Collegare il trasformatore CA al connettore sulla stampante.

(3) Collegare la spina del cavo di alimentazione ad una presa di corrente.

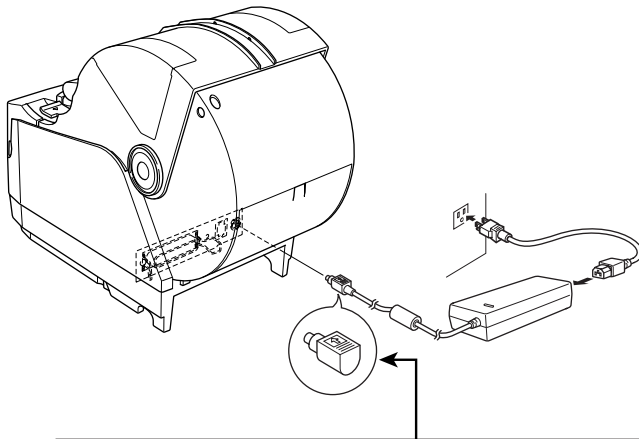

⚠ CAUTELA

Quando si scollega il cavo, afferrare il connettore del cavo per tirare. Sbloccando il fermo è facile scollegare il connettore.

Se si tira il cavo con forza eccessiva si possono causare danni al connettore.

4-4. Accensione

Assicurarsi che il trasformatore CA sia stato collegato come indicato nella sezione 4-3.

(1) Regolare su ON l'interruttore di alimentazione situato sul davanti della stampante.

La spia POWER sul pannello di controllo si illumina.



⚠ CAUTELA

Consigliamo di scollegare la stampante dalla presa di corrente quando si prevede di non usarla per un lungo periodo. Per questo motivo, la stampante deve essere collocata in modo che la presa di corrente sia vicina e facilmente accessibile.

4-5. Installazione del cavo

Installare il cavo come mostrato nello schema sotto.

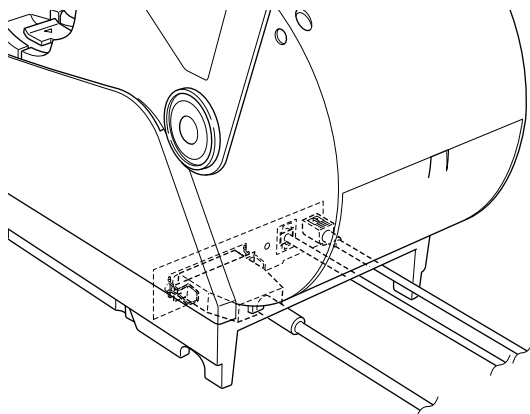
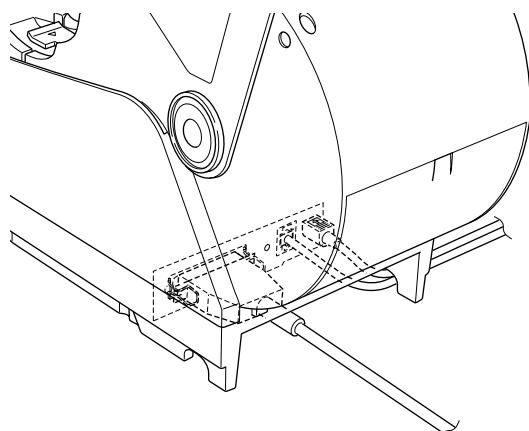
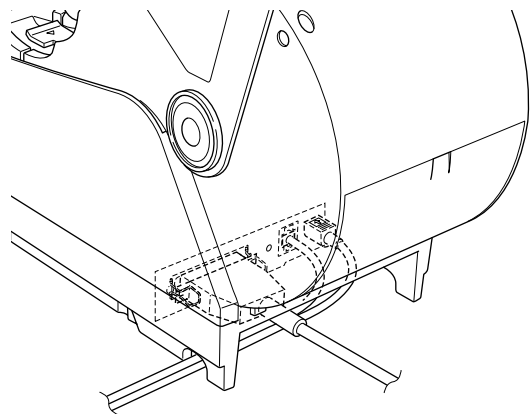

4-6. Installazione mascherina dell'interruttore

Non è necessario installare la mascherina dell'interruttore. Installarla solo se lo si ritiene necessario. Una volta installata la mascherina dell'interruttore, è possibile quanto segue.

- Impedire l'azionamento per errore dell'interruttore di alimentazione.
- Impedire ad altre persone di azionare facilmente l'interruttore di alimentazione.

Installare la mascherina dell'interruttore come mostrato nello schema sotto.

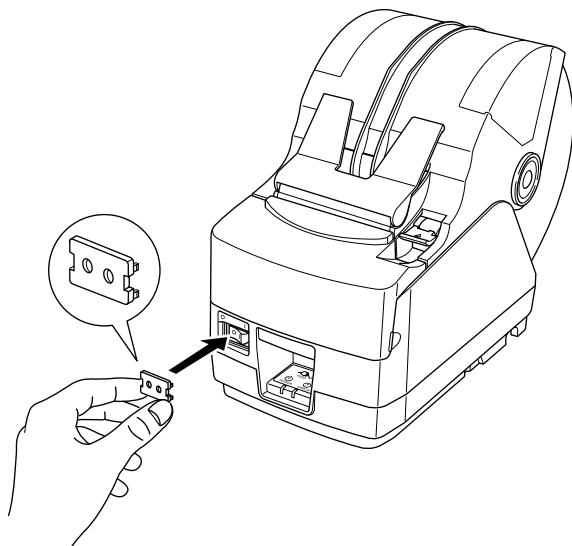

L'interruttore dell'alimentazione può essere portato sulla posizione ON (I) e OFF (O) inserendo un oggetto stretto (una penna a sfera, etc.) nei fori della mascherina dell'interruttore.

⚠ CAUTELA

Consigliamo di scollegare la stampante dalla presa di corrente quando si prevede di non usarla per un lungo periodo. Per questo motivo, la stampante deve essere collocata in modo che la presa di corrente sia vicina e facilmente accessibile.

5. Pannello di controllo e altre funzioni

5-1. Pannello di controllo

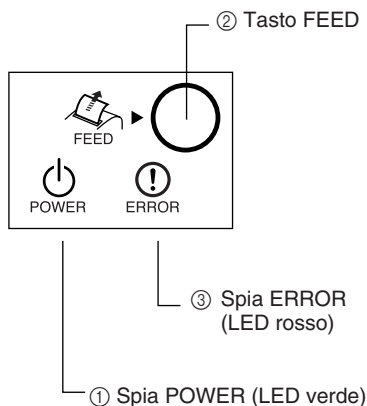

- ① Spia POWER (LED verde)
Si illumina quando l'unità è accesa.
- ② Tasto FEED
Premere il tasto FEED per far avanzare la carta su rotolo.
- ③ Spia ERROR (LED rosso)
Indica vari errori in combinazione con la spia POWER.

5-2. Errori

(1) Errori con recupero automatico

| Descrizione dell'errore | Spia POWER | Spia ERROR | Condizioni di recupero |
|--|---------------------------------------|------------|---|
| Individuazione temperatura testina elevata | Lampeggia a intervalli di 0,5 secondi | Spenta | Recupero automatico dopo che la testina di stampa si è raffreddata. |
| Errore di coperchio aperto | Accesa | Accesa | Recupero automatico con la chiusura del coperchio stampante. |

(2) Errore con recupero

| Descrizione dell'errore | Spia POWER | Spia ERROR | Condizioni di recupero |
|-------------------------|------------|---|---|
| Errore di taglio carta | Spenta | Lampeggia a intervalli di 0,125 secondi | Recupero se la taglierina ritorna alla posizione di riposo dopo che si è spenta e riaccesa l'unità. |

Nota:

- 1) Se la taglierina non ritorna alla posizione di riposo, o non esegue il movimento iniziale, il recupero non è possibile.
- 2) Se la carta è inceppata spegnere l'unità, eliminare l'inceppamento e quindi riaccendere.

(3) Errori senza recupero

| Descrizione dell'errore | Spia POWER | Spia ERROR | Behebungsbedingungen |
|-------------------------|------------|--|--|
| Errore RAM | Spenta | Lampeggia a intervalli di 1,0 secondi | Questo errore è senza recupero. Consultare il rivenditore per riparazioni. |
| Errore EERROM | Spenta | Lampeggia a intervalli di 0,75 secondi | Questo errore è senza recupero. Consultare il rivenditore per riparazioni. |
| Errore Flash ROM | Spenta | Lampeggia a intervalli di 0,5 secondi | Questo errore è senza recupero. Consultare il rivenditore per riparazioni. |
| Errore termistore | Spenta | Lampeggia a intervalli di 1,5 secondi | Questo errore è senza recupero. Consultare il rivenditore per riparazioni. |
| Errore alimentazione | Spenta | Lampeggia a intervalli di 2 secondi | Questo errore è senza recupero. Consultare il rivenditore per riparazioni. |

Nota:

- 1) Se si verifica un errore senza recupero, spegnere immediatamente l'unità.
- 2) Quando si verifica un errore alimentazione, esiste la possibilità che l'unità di alimentazione sia guasta.

Per altri errori senza recupero, consultare il rivenditore per riparazioni.

(4) Errori di rilevamento carta

| Descrizione dell'errore | Spia POWER | Spia ERROR | Condizioni di recupero |
|--------------------------|------------|---------------------------------------|---|
| Errore di carta esaurita | Accesa | Lampeggia a intervalli di 0,5 secondi | Recupero automatico quando si inserisce un nuovo rullo di carta e si chiude il coperchio stampante. |
| Carta quasi esaurita | Accesa | Lampeggia a intervalli di 2 secondi | Le spie indicano che la carta è quasi finita, ma la stampante continua a stampare. |

5-3. Stampa automatica

(1) Stampa di prova

Accendere l'unità tenendo premuto il tasto FEED.

La stampa di prova viene eseguita nell'ordine di numero di versione, impostazioni degli interruttori DIP e impostazioni dell'interruttore di memoria.

*** TSP1000 Ver1.00

Interface : Parallel

DIP Switch 1
Sw 12345678
On *****
Off

(2) Modo di scaricamento esadecimale

Aprire il coperchio stampante, quindi accendere l'unità tenendo premuto il tasto FEED. Quando si chiude il coperchio viene stampato "**** HEX DUMP PRINTING****" e la stampante passa al modo di scaricamento esadecimale. Ciascuno dei segnali inviati dal computer alla stampante viene stampante come codice esadecimale.

Questa funzione permette di controllare se un codice di controllo inviato alla stampante dal programma usato è corretto oppure no. L'ultima riga non viene stampata se i suoi dati con costituiscono una riga completa. Tuttavia, se si preme il tasto FEED, viene stampata l'ultima riga. Per disattivare questo modo è necessario spegnere completamente la stampante.

*** HEX DUMP PRINTING ***

| | |
|-------------------------|-------------|
| 20 21 22 23 24 25 26 27 | ! "\$%&' |
| 28 29 2A 2B 2C 2D 2E 2F | ()*+,-./ |
| 30 31 32 33 34 35 36 37 | 01234567 |
| 38 39 3A 3B 3C 3D 3E 3F | 89:;<=>? |
| 40 41 42 43 44 45 46 47 | @ABCDEFG |
| 48 49 4A 4B 4C 4D 4E 4F | HJKLMNO |
| 50 51 52 53 54 55 56 57 | PQRSTUVWXYZ |

6. Inserimento del rotolo di carta

6-1. Inserimento del rotolo di carta

La modalità di inserimento del rotolo di carta nella stampante varia in funzione del tipo di carta (rotolo di carta da inserire direttamente o rotolo di carta da inserire prima sull'asse). Inserire il rotolo di carta secondo le procedure descritte nella sezione 6-2.

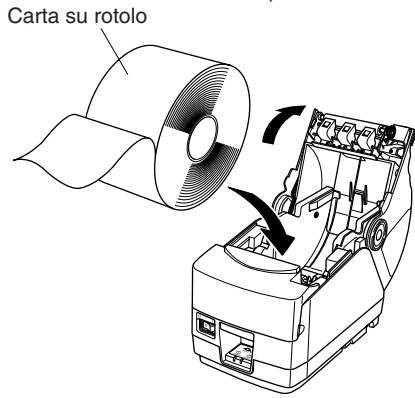
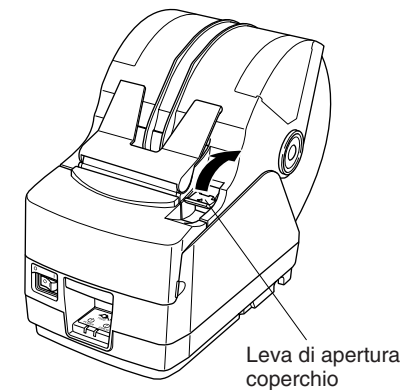

[Inserimento diretto della carta]

- (1) Spingere la leva di apertura coperchio e aprire il coperchio stampante.
- (2) Osservando l'orientamento del rotolo, inserire il rotolo di carta nel vano e tirare il bordo iniziale della carta verso di sé.

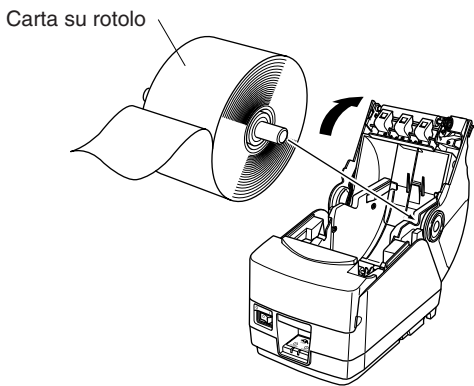
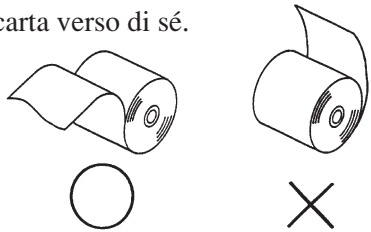

[Utilizzando l'asse]

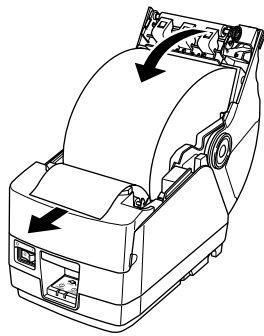

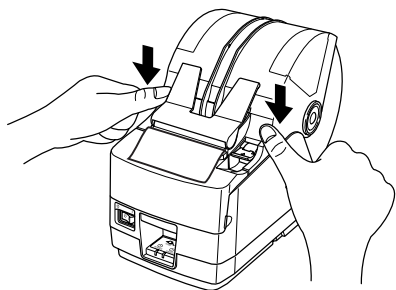

- (3) Tirare il bordo della carta per eliminare eventuali allentamenti e quindi abbassare entrambi i lati del coperchio stampante per chiuderlo.

Nota: Assicurarsi che il coperchio stampante sia saldamente chiuso.

- (4) Se il coperchio stampante è chiuso dopo l'accensione, la tagliarina agisce automaticamente e il bordo anteriore della carta viene tagliato.

Nota: Se la taglierna non funziona dopo che si è chiuso il coperchio stampante, aprire il coperchio e chiuderlo di nuovo saldamente.

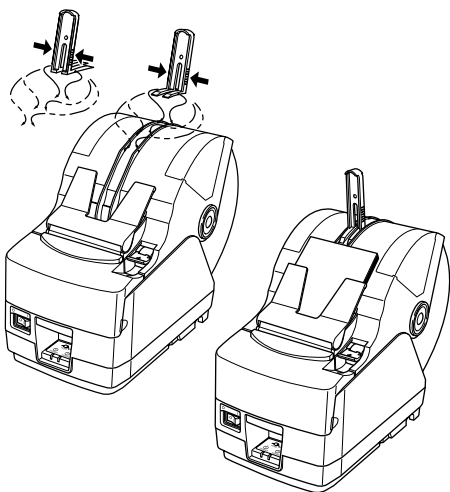

- (5) Se necessario, applicare il fermacarta al coperchio carta come mostrato. Il vassoio di uscita può contenere fino a 30 fogli (larghezza: 80–82,5 mm spessore: 80–120 mm, lunghezza: 50–150 mm). Per la carta di spessore diverso o di altre lunghezze, il limite è di 10 fogli.

Nota: Quando si applica il fermacarta al coperchio carta, posizionare il fermacarta secondo la lunghezza della carta in fogli. (Fare riferimento alla seguente tabella.)

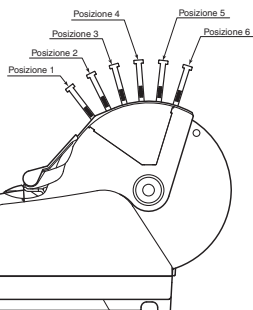

| | Lunghezza carta (mm) |
|-------------|----------------------|
| Posizione 1 | 50 – 100 |
| Posizione 2 | 100 – 120 |
| Posizione 3 | 120 – 140 |
| Posizione 4 | 140 – 160 |
| Posizione 5 | 160 – 180 |
| Posizione 6 | 180 – 200 |

⚠ ATTENZIONE

- *Non toccare la lama della taglierina.*
 - *All'interno della fessura di uscita carta si trova una taglierina. Non mettere mai la mano nella fessura di uscita della carta durante la stampa e non mettere mai la mano nella fessura anche quando la stampa non è in corso.*
 - *Il coperchio della stampante può essere aperto quando si sostituisce la carta. Tuttavia, poiché la lama della taglierina si trova all'interno del coperchio stampante, fare attenzione a non avvicinare eccessivamente le mani o il volto alla lama della taglierina.*
 - *Durante la stampante e subito dopo, l'area circostante la testina termica è molto calda. Non toccare perché si potrebbero subire ustioni.*
-

⚠ CAUTELA

- *Non azionare la leva di apertura del coperchio mentre si preme sul coperchio stampante con la mano.*
 - *Non estrarre la carta con il coperchio stampante chiuso.*
 - *L'elemento riscaldante e il circuito integrato pilota sulla testina termica si danneggiano facilmente. Non toccarli con oggetti metallici, carta vetrata, ecc.*
 - *Se l'elemento riscaldante della testina termica si è sporcato perché è stato toccato con le mani, la qualità di stampa può risentirne. Non toccare l'elemento riscaldante della testina termica.*
 - *Esiste il rischio di danni al circuito integrato pilota della testina di termica nel caso di elettricità statica. Non toccare mai direttamente il circuito integrato.*
 - *La qualità di stampa e la vita utile della testina termica non possono essere garantite se si usa qualsiasi carta diversa da quella consigliata. In particolare, carta contenente [Na+, K+, Cl-] può ridurre drasticamente la vita utile della testina termica. Si prega di fare attenzione.*
 - *Non usare la stampante se è presente umidità sulla parte anteriore della testina, a causa di condensa, ecc.*
-

6-2. Metodi di inserimento carta

Con questa stampante si utilizzano due metodi di inserimento carta: uno prevede l'utilizzo dell'asse del rotolo di carta, l'altro no. Quando la carta viene inserita direttamente, infatti, non si utilizza l'asse del rotolo. Servirsi della tabella seguente per determinare il metodo di inserimento carta in funzione del tipo di carta utilizzata.

| Larghezza carta (mm) \ Spessore carta (μm) | $44,5 \leq \text{Larghezza} < 79,5$ | $79,5 \leq \text{Larghezza} \leq 82,5$ |
|---|--|--|
| 65 Spessore < 80 | Utilizzare l'asse del rotolo di carta (*1, *4) | Utilizzare l'asse del rotolo di carta (*2) |
| $80 \leq \text{Spessore} \leq 120$ | Utilizzare l'asse del rotolo di carta (*1, *4) | Utilizzare l'inserimento diretto (*3) |
| $120 < \text{Spessore} \leq 150$ | Utilizzare l'asse del rotolo di carta (*1) | Utilizzare l'asse del rotolo di carta (*1) |

Nota:

- *1: Diametro esterno massimo del rotolo: 150 mm
- *2: Diametro esterno massimo del rotolo: 170 mm
- *3: Diametro esterno massimo del rotolo: 180 mm
- *4: È necessario passare dalla velocità di stampa alta (impostazione predefinita in fabbrica) alla velocità intermedia (140 mm/sec.). Per modificare la velocità di stampa, utilizzare il comando impostazioni velocità di stampa <ESC><RS> Rn. Per ulteriori dettagli, consultare il Manuale specifico separato.

6-3. Regolazione dei fermi del rotolo di carta

I fermi del rotolo di carta presentano due diverse dimensioni: i fermi 1 per la carta con nucleo dal diametro interno di 1 pollice ed i fermi 2 per la carta con nucleo dal diametro interno di 2 pollici. Selezionare i fermi in funzione delle dimensioni del rotolo carta utilizzato.

- (1) Installare i fermi del rotolo carta ad entrambe le estremità del relativo asse.
- (2) Regolare la posizione dei fermi secondo la larghezza della carta utilizzata.
- (3) Inserire l'asse con i fermi nel rotolo di carta.

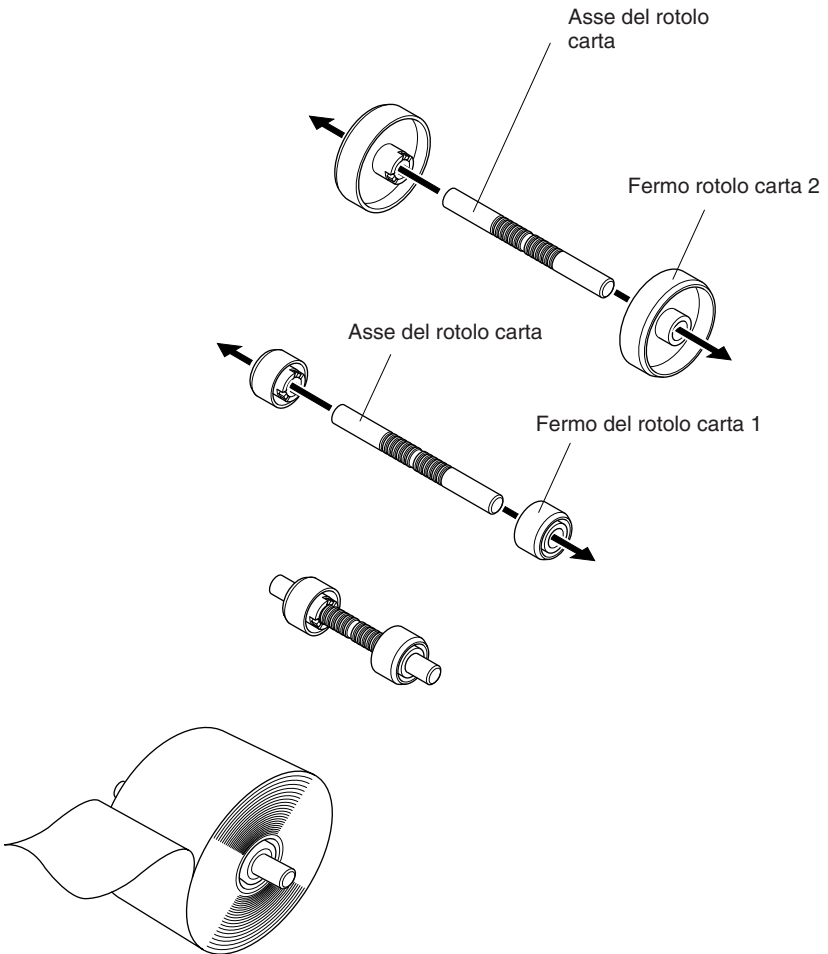

6-4. Regolazione delle guide della carta

Alla consegna della stampante, le guide carta e le guide superiori sono regolate per un rotolo di carta della larghezza seguente.

Larghezza carta: $79,5 \pm 0,5$ mm (TSP1043)

Larghezza carta: $82,5 \pm 0,5$ mm (TSP1045)

Quando si utilizza un rotolo di carta di larghezza diversa da quanto indicato sopra, procedere alla regolazione delle guide della carta nel modo seguente. Per regolare le guide superiori, consultare la parte “6-5 Regolazione delle guide superiori”.

- (1) Allentare le quattro viti.
- (2) Regolare le guide carta sinistra e destra in funzione della larghezza del rotolo di carta, facendo attenzione a lasciare uno spazio di circa 0,5 mm tra ciascuna delle guide ed il bordo della carta.

Le graduazioni sulla piastra di metallo all'interno della stampante sono suddivise in segmenti di 1 mm tra i segni \blacklozenge . I due segni \blacktriangledown sulle graduazioni sono utilizzati per la carta di larghezza pari a 57,5 mm, mentre i due segni \blacklozenge sono utilizzati per la carta di larghezza pari a 79,5 mm. Pertanto, per un rotolo di carta della larghezza di 79,5 mm, posizionare ciascuna guida a 0,5 mm all'esterno del rispettivo segno \blacklozenge (all'esterno). Se necessario, si potranno rimuovere le viti 2 e 3 ed installarle nei fori adiacenti.

- (3) Serrare le quattro viti.

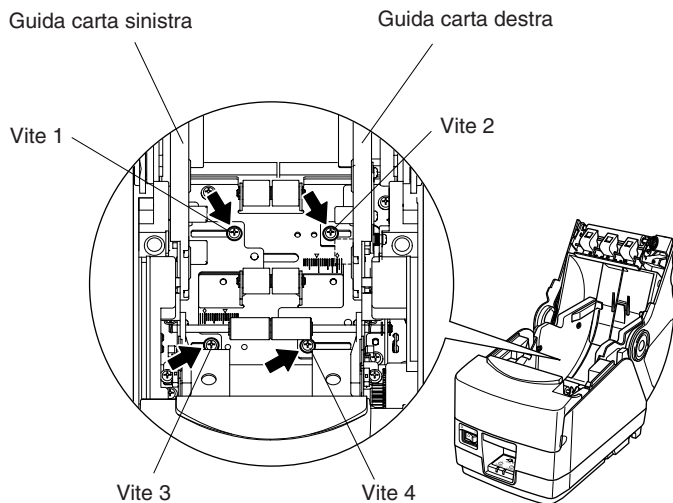

6-5. Regolazione delle guide superiori

Alla consegna della stampante, le guide superiori sono regolate per un rotolo di carta di larghezza pari a 79,5-82,5 mm. Quando si utilizzano rotoli di carta di larghezza diversa, procedere alla regolazione delle guide superiori nel modo seguente.

- (1) Allentare le due viti delle guide superiori sinistra e destra.
- (2) Regolare le guide superiori sinistra e destra in funzione della larghezza del rotolo di carta, facendo attenzione a posizionare ciascuna guida 2 mm all'interno del bordo della carta.

Le graduazioni sulla piastra di metallo del coperchio sono suddivise in segmenti di 1 mm. I due segni ▲ sotto le graduazioni sono utilizzati per la carta di larghezza pari a 57,5 mm, mentre i due segni sono ◆ utilizzati per la carta di larghezza pari a 79,5 mm (nonché per la carta di larghezza pari a 82,5 mm). Se necessario, è possibile spostare le viti delle guide superiori sinistra e destra nei fori adiacenti. Se il rotolo di carta ha una larghezza uguale o inferiore a 50 mm, rimuovere la guida superiore centrale togliendo la vite, quindi regolare le guide superiori sinistra e destra.

Nota:

Nel regolare le guide superiori, fare attenzione a non pizzicare i fili o a sottoporli ad un'eccessiva pressione.

- (3) Serrare le due viti.

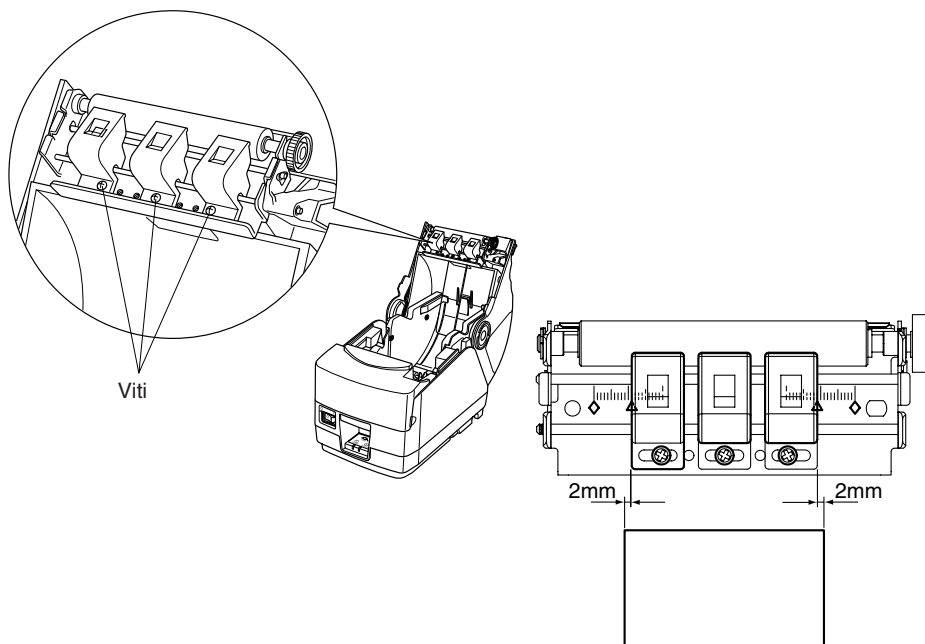

7. Regolazione del sensore di esaurimento prossimo

Usare il seguente procedimento per regolare il sensore di esaurimento prossimo in modo che sia compatibile con le dimensioni del rotolo di carta usato.

- ① Aprire il coperchio stampante.
- ② Determinare la posizione corretta del regolatore tra le tre posizioni seguenti in funzione del metodo di inserimento carta e del diametro interno del nucleo del rotolo di carta.

Posizione 1: quando il rotolo di carta viene inserito direttamente

Posizione 2: quando si utilizza la fermo 2 del rotolo carta (ϕ nucleo interno pari a 50,8 mm)

Posizione 3: quando si utilizza la fermo 1 del rotolo carta (ϕ nucleo interno pari a 25,4 mm)

- ③ Inserire la punta di una penna a sfera o un oggetto simile nel foro sul regolatore e quindi premere e spostare il regolatore sull'impostazione desiderata.

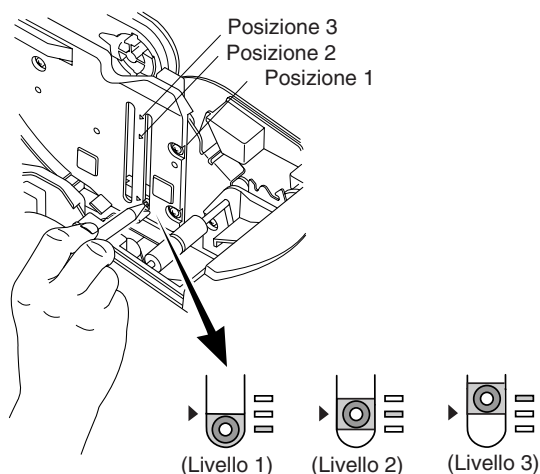

Nella tabella seguente sono indicate le quantità di carta rimanente che è possibile rilevare.

(1) Posizione 1

| Spessore carta (μm) | Quando si utilizza un rotolo di carta con diametro interno del nucleo (A): $\phi 25,4$ e diametro esterno del nucleo (B): $\phi 40$ | | | | | |
|----------------------------------|---|-----------|-----------|--|-----------|-----------|
| | Diametro individuato (C) (mm circa) | | | Lunghezza carta rimanente (m circa) | | |
| | Livello 1 | Livello 2 | Livello 3 | Livello 1 | Livello 2 | Livello 3 |
| 80 | $\phi 44$ | $\phi 48$ | $\phi 52$ | 3,5 | 7,5 | 12,5 |
| 105 | | | | 1,5 | 4,5 | 7,5 |

(2) Posizione 2

| Spessore carta (μm) | Quando si utilizza un rotolo di carta con diametro interno del nucleo (A): $\phi 25,4$ e diametro esterno del nucleo (B): $\phi 40$ | | | | | |
|----------------------------------|---|-----------|-----------|--|-----------|-----------|
| | Diametro individuato (C) (mm circa) | | | Lunghezza carta rimanente (m circa) | | |
| | Livello 1 | Livello 2 | Livello 3 | Livello 1 | Livello 2 | Livello 3 |
| 65 | — | $\phi 45$ | — | — | 5,6 | — |
| 80 | | | | | 4,4 | |
| 105 | | | | | 3,2 | |

(3) Posizione 3

| Spessore carta (μm) | Quando si utilizza un rotolo di carta con diametro interno del nucleo (A): $\phi 50,8$ e diametro esterno del nucleo (B): $\phi 58$ | | | | | |
|----------------------------------|---|-----------|-----------|--|-----------|-----------|
| | Diametro individuato (C) (mm circa) | | | Lunghezza carta rimanente (m circa) | | |
| | Livello 1 | Livello 2 | Livello 3 | Livello 1 | Livello 2 | Livello 3 |
| 150 | — | $\phi 69$ | — | — | 6,5 | — |

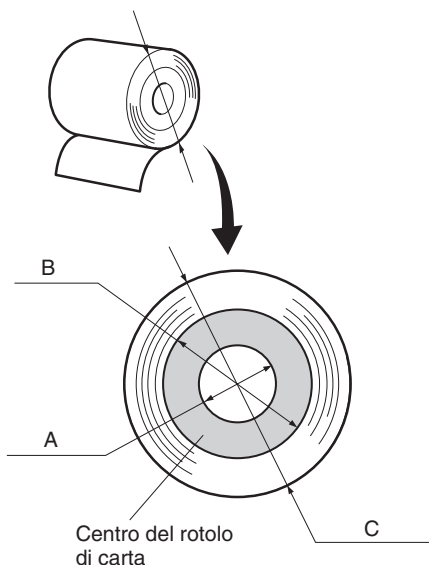

Nota:

- 1) Prima che la macchina lasci la fabbrica, il regolatore viene posizionato nella posizione 1, livello 2.
- 2) La dimensione C e la lunghezza di carta rimanente sono valori calcolati. Si possono avere leggere variazioni nell'uso effettivo.
- 3) Le lunghezze carta rimanente indicate nella tabella sono solo di riferimento. Regolare il sensore di esaurimento prossimo sulle condizioni effettive di impiego.
- 4) Se si utilizza carta spessa (di spessore uguale o superiore a $100 \mu\text{m}$) con il regolatore posizionato sul posizione 1, nel rotolo di carta si creano allentamenti che favoriscono il verificarsi di variazioni nel rilevamento. Impostare sul Livello 3.

8. Prevenzione e soluzione degli inceppamenti della carta

8-1. Prevenzione degli inceppamenti della carta

La carta non deve essere toccata durante l'espulsione e prima che sia tagliata. Se si preme o si tira la carta durante l'espulsione si può verificare un inceppamento della carta, un mancato taglio della carta o un avanzamento di riga mancato.

8-2. Eliminazione degli inceppamenti della carta

Se si verifica un inceppamento della carta, eliminarlo come descritto di seguito.

- (1) Regolare l'interruttore di alimentazione su OFF per spegnere la stampante.
- (2) Spingere la leva di apertura coperchio e aprire il coperchio stampante.
Se il coperchio stampante non si apre sui modelli dotati di taglierina automatica, vuol dire che la taglierina automatica non è nella posizione di riposo. In questo caso, riportare la taglierina automatica alla posizione di riposo seguendo le istruzioni fornite nella sezione 8-3. Poi aprire il coperchio stampante dopo aver eliminato l'inceppamento carta.
- (3) Rimuovere la carta inceppata.

CAUTELA

Fare attenzione a non danneggiare la stampante quando si rimuove la carta inceppata. Poiché la testina di stampa in particolare viene danneggiata facilmente, fare attenzione a non toccarla.

- (4) Collocare diritto il rotolo di carta e chiudere delicatamente il coperchio stampante.

Note:

- 1) Assicurarsi che la carta sia ben diritta. Se si chiude il coperchio stampante con la carta storta, si può verificare un inceppamento della carta.
 - 2) Bloccare il coperchio stampante premendo in basso entrambi i lati. Assicurarsi che il coperchio stampante sia saldamente chiuso.
- (5) Regolare su ON l'interruttore di alimentazione per accendere la stampante. Assicurarsi che la spia ERROR non sia illuminata.
Nota: Mentre la spia ERROR è illuminata, la stampante non accetta alcun comando come il comando di stampa, per cui assicurarsi che il coperchio della stampante sia bloccato correttamente.

8-3. Rilascio della taglierina bloccata

Se la taglierina automatica si blocca o non taglia la carta, procedere come segue.

⚠ ATTENZIONE

Poiché lavorare con la taglierina può essere pericoloso, non dimenticare di spegnere prima la stampante.

- (1) Regolare l'interruttore di alimentazione su OFF per spegnere la stampante.
- (2) Spostare il coperchio anteriore per scoprire la taglierina automatica.
- (3) Rimuovere eventuale carta inceppata.

⚠ CAUTELA

Fare attenzione a non danneggiare la stampante durante la rimozione della carta inceppata.

Poiché la testina di stampa termica è particolarmente sensibile, fare attenzione a non toccarla.

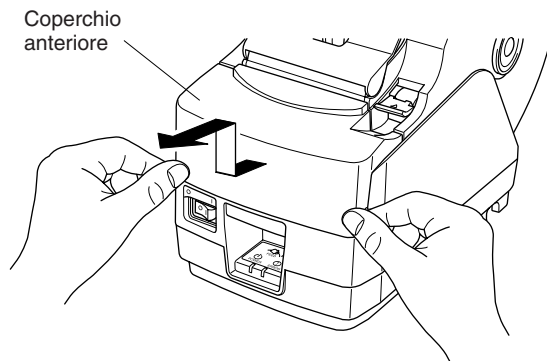

- (4) Se la lama mobile della taglierina sporge, girare la manopola in direzione della freccia per riportare la lama mobile alla sua posizione di partenza.
Quando la finestrella di controllo appare completamente bianca, la lama mobile è nella sua posizione di partenza.

⚠ CAUTELA

- 1) *Non applicare estrema pressione alla lama mobile.*
2) *Se la lama mobile sporge eccessivamente, non è possibile aprire il coperchio stampante. Se si tenta di aprire il coperchio stampante si può danneggiare la taglierina.*
-

- (5) Aprire il coperchio stampante, rimuovere eventuale carta inceppata e quindi reinstallare il rotolo di carta.
(6) Installare il coperchio anteriore e quindi regolare l'interruttore di alimentazione su ON.

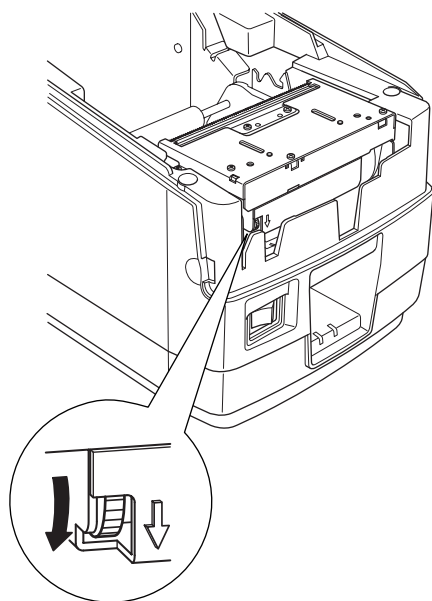

9. Pulizia periodica

I caratteri stampati possono diventare parzialmente poco chiari a causa dell'accumulo di polvere di carta e sporczia. Per evitare tale problema, è necessario rimuovere periodicamente la polvere di carta accumulata nel comparto carta, nella sezione di trasporto carta e sulla superficie della testina termica. Si consiglia di eseguire questa pulizia una volta ogni sei mesi oppure ogni milione di righe stampate.

9-1. Pulizia della testina termica

Per rimuovere la polvere nerastra accumulata sulla superficie della testina di stampa, passarla con alcool isopropile (IPA).

Nota: La testina termica si danneggia facilmente, per cui pulirla delicatamente con un panno morbido. Fare attenzione a non graffiarla durante la pulizia.

9-2. Pulizia del comparto carta

Usare un panno morbido per eliminare la polvere di carta dal comparto carta e dalla sezione di trasporto della carta.

Appendix A: Specifications

A-1. General Specifications

- | | |
|-----------------------------|---|
| (1) Printing method | Direct line thermal printing |
| (2) Print speed | Max. 1440 dots/sec. (180 mm/sec.) |
| (3) Dot density | 203 dpi: 8 dots/mm (0.125 mm/dot) |
| (4) Printing width | Factory default : 72 mm (TSP1043) : 80 mm (TSP1045) |
| (5) Number of print columns | 53 (12 × 24 dots) |
| (6) Roll paper | Refer to chapter 3 for details on the recommended roll paper. |
| (7) Overall dimension | 161 (W) × 307 (D) × 249 (H) mm |
| (8) Weight | Approx. 3.0 kg |
| (9) Noise Approx. | 57 dB |

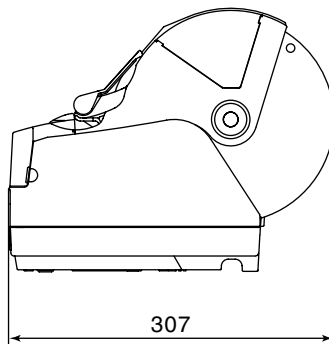
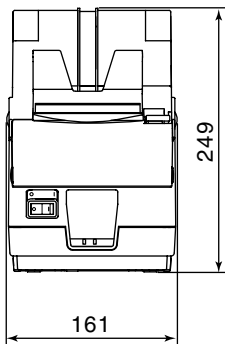
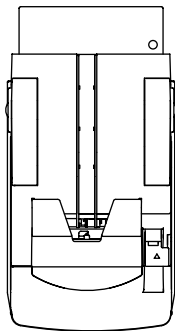

Unit : mm

A-2. Auto Cutter Specifications

- (1) Cutting frequency Max. 20 cuts per minute
(2) Thickness of paper 0.065 ~ 0.150 mm

A-3. Interface

RS232C serial interface/Two-way parallel interface (IEEE1284)/USB interface/
Ethernet interface/Wireless LAN Interface

A-4. Electrical Characteristics

- (1) Input Voltage DC 24V±10%
(2) Current Consumption Operating: Approx. 2.0 A (at ASCII printing)
 Peak: Approx. 10 A
 Stand-by: Approx. 0.1 A
(3) Power Connector

| Pin No. | Function |
|---------|--------------|
| 1 | Drive power |
| 2 | Signal GND |
| 3 | N.C. |
| Shell | Frame ground |

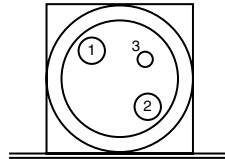

<Viewed from Connector Surface>

Note:

- When using a printer power supply other than the optional AC adaptor (PS60), be sure that the following cautions are observed.
- Use a power supply of DC 24 V ±10% and more than 2.0 A (5.0 A Load 10 sec. Min) with SELV output approved by IEC60950.
- Be careful about installing the printer in an area where there is noise. Take the appropriate measures to protect against electrostatic AC line noise, etc.

A-5. Option

- (1) USB Interface Board Unit (IFBD-HU04)
(2) Parallel Interface Board Unit (IFBD-HC04)
(3) 25 Pin RS-232C Interface Board Unit (IFBD-HD04)
(4) 9 Pin RS-232C Interface Board Unit (IFBD-HN04)
(5) Ethernet Interface Board Unit (IFBD-HE04)
(6) Wireless LAN interface Board Unit (IFBD-HW04)

A-6. Environmental Requirements

(1) Operating

Temperature

5°C to 45°C

Humidity

10% to 90% RH (without condensation)

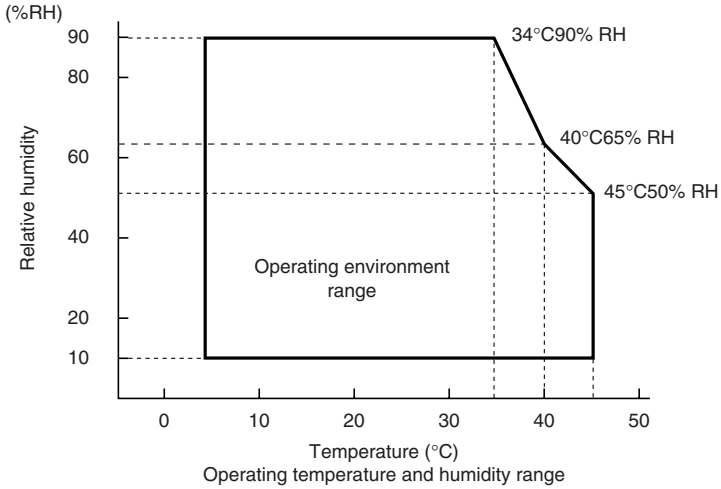

(2) Transport/storage (except for paper)

Temperature

-20°C to 60°C

Humidity

10% to 90% RH (without condensation)

A-7. Reliability

(1) LIFE

20 million lines (based on an average printing rate of 12.5% with paper thickness in the range 80 µm to 85 µm)

(2) Cutter life

1.0 million cuttings (if the paper thickness is 100 µm or less)

0.3 million cuttings (if the paper thickness is more than 100 µm)

A-8. Black Mark Specifications

When using the paper-end sensor as a black mark sensor, the following settings are recommended.

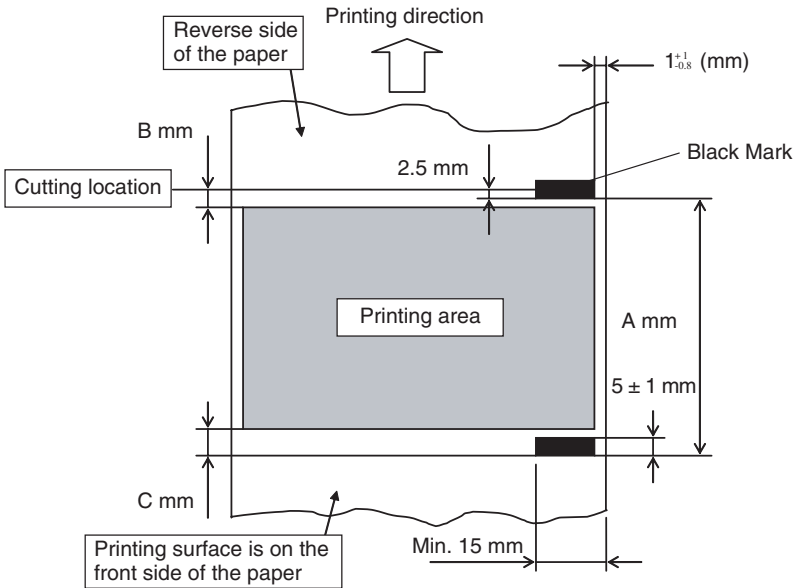

Note:

The paper is cut at the location shown above when the memory switch is set to the default setting for the printing start location offset value.

1. Black mark pitch (dimension A)

Dimension A for the black mark pitch can be set to 50–300 mm.

Note:

Although the black mark pitch can be set in the range listed above, it is recommended that you consider the variations that occur with the printing location when setting the print layout.

2. Black mark dimensions

Refer to the above figure for the dimensions of the black marks that will be printed.

3. PCS value

The PCS value of the black marks that will be printed should be a minimum of 0.90 (90%).

Note:

If the PCS value of the black marks does not meet the specification listed above, page skipping and page length detection errors may occur. To avoid problems, make sure that the specified PCS value is used.

4. Top margin (dimension B)

When setting the printing area, leave a sufficient top margin between the cutting location and the top of the printing area.

When not using reverse paper feeding, a top margin of at least 12 mm is recommended: 11 mm for the distance between the thermal head heating element and the cutting location, and 1 mm for the paper feeding that occurs due to the vibrations when the motor starts.

Note:

- 1) If the top margin is insufficient, page skipping errors may occur. To avoid problems, set the top margin carefully.
- 2) The printing area setting should not exceed the black mark pitch.

5. Bottom margin (dimension C)

When setting the printing area, leave a sufficient bottom margin between the bottom of the printing area and the following black mark.

When setting the bottom margin, consider the printing precision of the black mark pitch, TOF printing precision (± 2 mm from the standard printing location), ambient temperature at the installation location, and the amount of wear of the printer parts. It is recommended to set the printing area to achieve the following bottom margin.

Bottom margin (dimension C) ≥ 3 mm + (dimension A \times 3%)

Note:

- 1) If the bottom margin is insufficient, page skipping errors may occur. To avoid problems, set the bottom margin carefully.
- 2) The printing area setting should not exceed the black mark pitch.

6. Example of printing area setting

An example of the settings for the printing area when not using reverse paper feeding is shown below.

Black mark pitch (dimension A): 100 mm

Top margin: 12 mm

Bottom margin: 3 mm + (100 mm × 0.03) = 6 mm

Given the above settings, the printing area must be set to 82 mm or less (100 mm - 12 mm - 6 mm = 82 mm).

Note:

- 1) Be careful when setting the print layout for pre-printed paper. The TOF printing precision when detecting black marks is ± 2 mm from the standard printing location. In addition, the printing length is $\pm 2\%$ of the set value according to variations with the initial ambient temperature and platen diameter precision, and a margin of error of up to -5% may occur according to the life of the printer.
- 2) If you have any questions regarding how to set the printing area according to the black mark pitch, contact Star Micronics.

7. Sensor adjustment

When using black marks, it is recommended to adjust the black mark sensor.

Appendix B: Dip Switch Setting

Two DIP switches are provided at the bottom of the printer, and can be set as given in the table below. Be sure to set the power switch to off before changing the settings. It is recommended to use a pointed item like a pen or flat-blade driver screw to change the settings. The settings will become effective when the power switch is set to on again.

The following is the procedure for changing the settings on DIP switches.

1. Make sure the printer is turned off.
2. Remove the screw from the DIP switch cover. Then take off the DIP switch cover, as shown in the illustration below.

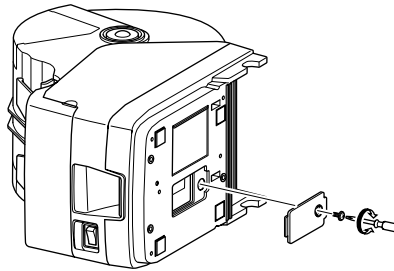

3. Set the switches using a pointed tool, such as a pen or flat-blade screwdriver.
4. Replace the DIP switch cover. Then secure it with the screw. The new settings take effect when you turn on the printer.

B-1. Parallel Interface Model

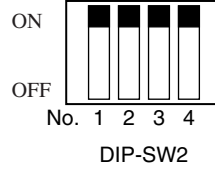
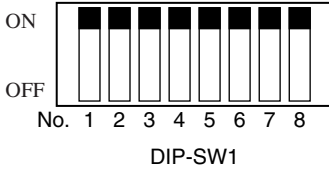

DIP-SW 1

| Switch | Function | ON | OFF |
|--------|---|-----------------------------------|---------------------|
| 1-1 | Command emulation | See table below | |
| 1-2 | Command emulation | | |
| 1-3 | Should not be changed (Should be set to on) | | |
| 1-4 | Sensor adjustment | Valid | Invalid |
| 1-5 | Pin #31 (INIT) reset signal | Valid | Invalid |
| 1-6 | Handshaking conditions (conditions for BUSY) | Offline or receive buffer full | Receive buffer full |
| 1-7 | Automatic status back function | Invalid | Valid |
| 1-8 | Should not be changed (Should be set to on) | | |

The factory settings of DIP switch are all on.

| Switch 1-1 | Switch 1-2 | Command emulation |
|------------|------------|-------------------|
| ON | ON | Star Line Mode |
| OFF | ON | Star Page Mode |
| OFF | OFF | ESC/POS Mode |

DIP-SW 2

| Switch | Function | ON | OFF |
|--------|-----------|---------------------|-----|
| 2-1 | Always ON | Should be set to on | |
| 2-2 | | | |
| 2-3 | | | |
| 2-4 | | | |

The factory settings of DIP switch are all on.

B-2. Serial Interface (RS-232C) Model

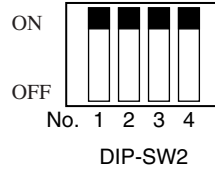
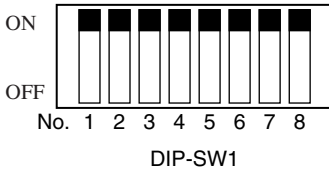

DIP-SW 1

| Switch | Function | ON | OFF |
|--------|---|-----------------------------------|---------------------|
| 1-1 | Command emulation | See table below | |
| 1-2 | Command emulation | | |
| 1-3 | Should not be changed (Should be set to on) | | |
| 1-4 | Sensor adjustment | Valid | Invalid |
| 1-5 | Should not be changed (Should be set to on) | | |
| 1-6 | Handshaking conditions (conditions for BUSY) | Offline or receive buffer full | Receive buffer full |
| 1-7 | Automatic status back function | Invalid | Valid |
| 1-8 | Should not be changed (Should be set to on) | | |

The factory settings of DIP switch are all on.

| Switch 1-1 | Switch 1-2 | Command emulation |
|------------|------------|-------------------|
| ON | ON | Star Line Mode |
| OFF | ON | Star Page Mode |
| OFF | OFF | ESC/POS Mode |

DIP-SW 2

| Switch | Function | ON | OFF |
|--------|-----------|---------------------|-----|
| 2-1 | Always ON | Should be set to on | |
| 2-2 | | | |
| 2-3 | | | |
| 2-4 | | | |

The factory settings of DIP switch are all on.

The following is the procedure for changing the settings on DIP switch No. 3.

1. Turn off the printer and all components connected to it.
2. Remove the 2 screws.
3. Remove the serial interface board unit.
4. Change the setting of the DIP switches.
5. Replace the serial interface board unit.
Then secure it with the screws.
6. Turn on the printer and all components connected to it.

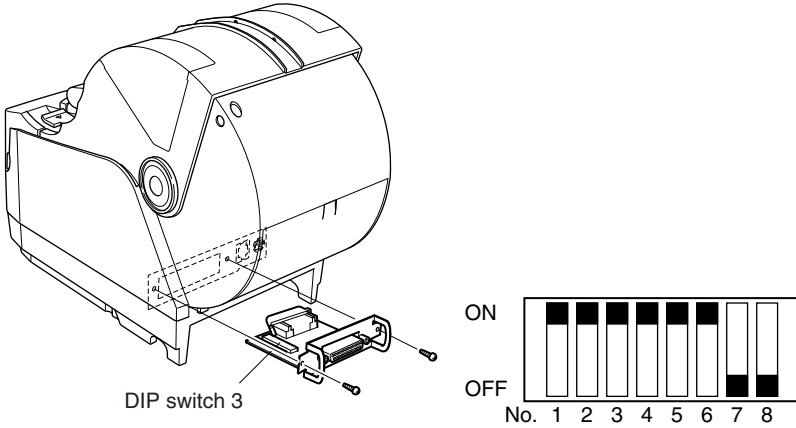

DIP-SW3

The factory settings of DIP switch are all on, except for switches 7 and 8.

DIP-SW 3

| Switch | Function | ON | OFF |
|--------|--|-----------------|----------|
| 3-1 | Baud Rate | See table below | |
| 3-2 | | | |
| 3-3 | Data Length | 8 bits | 7 bits |
| 3-4 | Parity Check | Disabled | Enabled |
| 3-5 | Parity | Odd | Even |
| 3-6 | Handshake | DTR/DSR | XON/XOFF |
| 3-7 | Should not be changed (Should be set to off) | — | — |
| 3-8 | | | |

| Baud Rate | Switch 3-1 | Switch 3-2 |
|-----------|------------|------------|
| 4800BPS | OFF | ON |
| 9600BPS | ON | ON |
| 19200BPS | ON | OFF |
| 38400BPS | OFF | OFF |

B-3. USB Interface Model

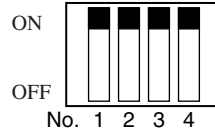

DIP-SW1

| Switch | Function | ON | OFF |
|--------|---|-----------------------------------|-----------------------|
| 1-1 | Command emulation | See table below | |
| 1-2 | Command emulation | | |
| 1-3 | Should not be changed (Should be set to on) | | |
| 1-4 | Sensor adjustment | Valid | Invalid |
| 1-5 | USB mode | Mode 1 (Printer class) | Mode 2 (Vendor class) |
| 1-6 | Handshaking conditions (conditions for BUSY) | Offline or receive buffer full | Receive buffer full |
| 1-7 | Automatic status back function | Model 1 | (Should be set to on) |
| | | Model 2 | |
| 1-8 | Should not be changed (Should be set to on) | | |

The factory settings of DIP switch are all on.

| Switch 1-1 | Switch 1-2 | Command emulation |
|------------|------------|-------------------|
| ON | ON | Star Line Mode |
| OFF | ON | Star page Mode |
| OFF | OFF | ESC/POS Mode |

Note:

- 1) A STAR USB Printer Driver Set is needed for using the USB interface on Windows 98 or 98SE . You can download the STAR USB Printer Driver Set from the following website.
- 2) Download the Mode 2 (vendor class) driver set from the following website for use.

Printer Driver URL <http://www.star-m.jp/eng/dl/dl02.htm>

DIP-SW 2

| Switch | Function | ON | OFF |
|---------|-----------|---------------------|-----|
| 2-1~2-4 | Always ON | Should be set to on | |

The factory settings of DIP switch are all on.

B-4. Ethernet Interface Model

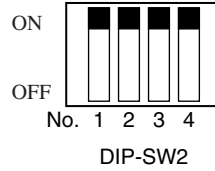
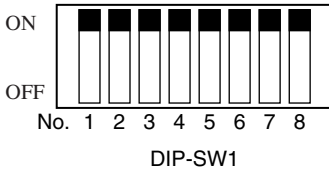

DIP-SW1

| Switch | Function | ON | OFF |
|--------|---|-----------------------------------|---------------------|
| 1-1 | Command emulation | See table below | |
| 1-2 | Command emulation | | |
| 1-3 | Should not be changed (Should be set to on) | | |
| 1-4 | Sensor adjustment | Valid | Invalid |
| 1-5 | Should not be changed (Should be set to on) | | |
| 1-6 | Handshaking conditions (conditions for BUSY) | Offline or receive buffer full | Receive buffer full |
| 1-7 | Should not be changed (Should be set to on) | | |
| 1-8 | Should not be changed (Should be set to on) | | |

The factory settings of DIP switch are all on.

| Switch 1-1 | Switch 1-2 | Command emulation |
|------------|------------|-------------------|
| ON | ON | Star Line Mode |
| OFF | ON | Star Page Mode |
| OFF | OFF | ESC/POS Mode |

DIP-SW 2

| Switch | Function | ON | OFF |
|---------|-----------|---------------------|-----|
| 2-1~2-4 | Always ON | Should be set to on | |

The factory settings of DIP switch are all on.

DIP-SW 3

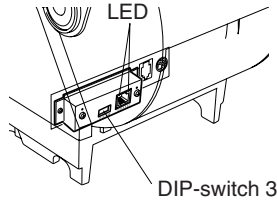

| Switch | Function | ON | OFF |
|--------|---|----------------------|---------|
| 3-1 | Always OFF | Should be set to off | |
| 3-2 | Initialization of settings | Valid | Invalid |
| 3-3 | Always OFF | Should be set to off | |
| 3-4 | #9100 Multi-session (Maximum 8 sessions) | Valid | Invalid |

The factory settings of DIP switch are all OFF.

The firmware must be ver.2.02 or later.

■ LED Display

Green : Lights when other party connection is recognized as 10BASE-T.

Orange : Lights when packets are received.

Installing the Printer Driver and the LPR Port Driver Set

To use the Ethernet interface from Microsoft's Windows 95/98 and ME, the "Star LPR Port Driver Set" along with the printer driver is necessary.

Download the Printer Driver and the Star LPR Port Driver Set from the following Web site.

Printer Driver URL : <http://www.star-m.jp/eng/dll/dl02.htm>

* To use Windows NT 4.0/2000/XP, the "Star LPR Port Driver Set" is unnecessary.

B-5. Wireless LAN Interface Model

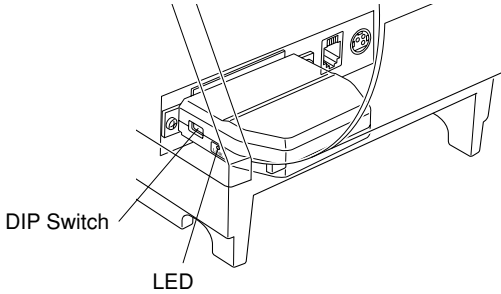

| DIP Switch | ON | OFF |
|------------|-----------------------------------|-----|
| 1 | Fixed at OFF | |
| 2 | Initialize of setting information | — |

The factory settings of DIP switch are all off.

LED Display

Green : Lights when pockets are received.

Installing the Printer Driver and the LPR Port Driver Set

To use the wireless LAN interface from Microsoft's Windows 95/98 and ME, the "Star LPR Port Driver Set" along with the printer driver is necessary.

Download the Printer Driver and the Star LPR Port Driver Set from the following Web site.

Printer Driver URL : <http://www.star-m.jp/eng/dl/dl02.htm>

* To use Windows NT 4.0/2000/XP, the "Star LPR Port Driver Set" is unnecessary.

Note:

- This product contains a built-in wireless device and can only be used in the following countries.

Dieses Produkt enthält eine eingebaute drahtlose Einrichtung und kann nur in den folgenden Ländern verwendet werden.

Ce produit renferme un dispositif sans fil incorporé et il ne peut être utilisé que dans les pays suivants.

Questo prodotto contiene un dispositivo senza fili incorporato e può essere utilizzato solo nei seguenti paesi.

USA, UK, France, Ireland, Belgium, Germany, Austria, Switzerland, Italy, Denmark, Norway, Sweden, Portugal, Spain, Estonia, Finland, Greece, Liechtenstein, Luxemburg, Netherlands, Canada, Slovakia, Slovenia, Czech, Hungary, Poland, Latvia, and Lithuania.

- *This product contains Transmitter Module which conforms to the R&TTE Directive.
- *This roduct ontains Transmitter odule FCC ID: 4B6180210.
- *This roduct ontains Transmitter odule IC: 844A-66180210.
- *Strictly observe the export control laws of the country for export when exporting this product.

Installing the Ferrite Core (Wireless LAN Model for EU Only)

Install the ferrite core onto the buzzer drive cable to prevent radio interference. Use the ferrite core only for the wireless LAN model in the EU.

- ① Install the ferrite core onto the buzzer drive cable as shown in the illustration.

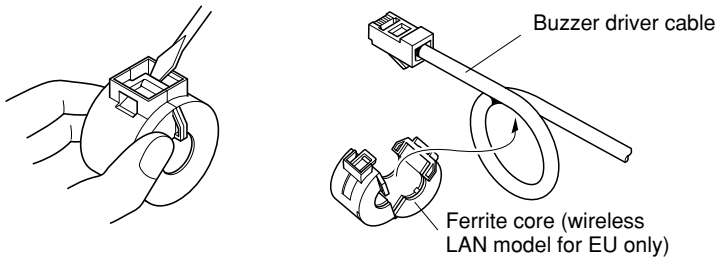

- ② Pass the fastener through the holes in the ferrite core as shown in the illustration.

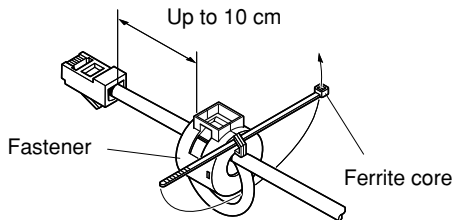

- ③ Loop the fastener around the cable, and then pull the end of the fastener tightly through its buckle. Use a pair of scissors to cut off the excess end of the fastener.

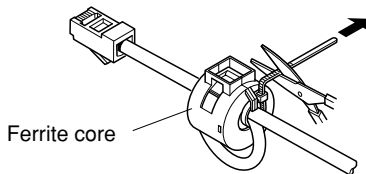

Connecting the buzzer drive cable

Connect the buzzer drive cable to the connector on the printer. Then, connect the other end of the cable to the buzzer drive circuit.

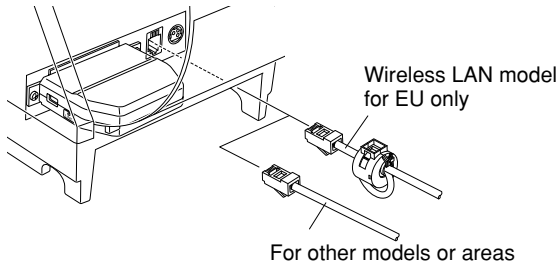

Appendix C: Parallel Interface

The two-way parallel interface is compatible with the IEEE1284 compatibility mode and nibble mode. Refer to the separate Specification Manual for details.

Table of Connection Signals for Each Mode

| Pin No. | Direction | Compatibility Mode Signal Name | Nibble Mode Signal Name |
|---------|-----------|--------------------------------|-------------------------|
| 1 | In | nStrobe | Host Clock |
| 2 | In/Out | Data0 | Data0 |
| 3 | In/Out | Data1 | Data1 |
| 4 | In/Out | Data2 | Data2 |
| 5 | In/Out | Data3 | Data3 |
| 6 | In/Out | Data4 | Data4 |
| 7 | In/Out | Data5 | Data5 |
| 8 | In/Out | Data6 | Data6 |
| 9 | In/Out | Data7 | Data7 |
| 10 | Out | nAck | PtrClk |
| 11 | Out | Busy | PtrBusy/Data3,7 |
| 12 | Out | PError | AckDataReq/Data2,6 |
| 13 | Out | Select | Xflag/Data1,5 |
| 14 | | — | HostBusy |
| 15 | | — | — |
| 16 | | Signal GND | Signal GND |
| 17 | | Frame GND | Flame GND |
| 18 | OUT | +5V | +5V |
| 19~30 | | Twisted Pair Return | Twisted Pair Return |
| 31 | In | nInit | nInit |
| 32 | Out | nFault | nDataAvail/Data0,4 |
| 33 | | External GND | — |
| 34 | | — | — |
| 35 | | — | — |
| 36 | In | nSelectIn | 1284Active |

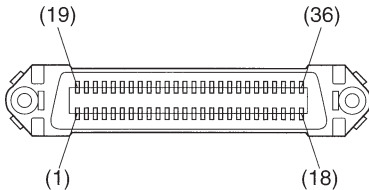

This connector mates with an Amphenol 57-30360 connector

Parallel interface connector (printer side)

Note:

- 1) The first letter “n” of each signal name indicates that the signal is active “L”. If any one of the above signals is not available, bidirectional communication cannot be accomplished.
- 2) In interfacing signals, be sure to use twist-paired wires for signal lines, and the return side must be connected to signal ground level.

Appendix D: Serial Interface (RS-232C)

D-1. RS-232C Connector

| Pin No. | | Signal name | Direction | Function |
|---------|-------|-------------|-----------|--|
| 25 Pin | 9 Pin | | | |
| 1 | | F-GND | — | Frame ground |
| 2 | 3 | TXD | OUT | Transmission data |
| 3 | 2 | RXD | IN | Receive data |
| 4 | 7 | RTS | OUT | Same as DTR signal. |
| 5 | | N/C | | Not used |
| | 8 | CTS | IN | Status of this signal is not checked. |
| 6 | 6 | DSR | IN | <p>STAR Mode Status of this signal is not checked.</p> <p>ESC/POS Mode In DTR/DSR communication mode, indicates whether data receive from host is enabled or disabled. Space: Receive enabled Mark: Receive disabled (except when transmitting data by DLE EOT, and GS a) This signal is not checked in the X-ON/X-OFF communication mode.</p> |
| 7 | 5 | S-GND | — | Signal ground |
| 8~19 | 1,9 | N/C | | Not used |
| 20 | 4 | DTR | OUT | <p>STAR Mode Indicates whether data receive from host is enabled or disabled.</p> <p>1) DTR/DSR Communication Mode Space when receive is enabled.</p> <p>2) X-On/X-Off Communication Mode Always space, except during following conditions:</p> <ul style="list-style-type: none"> • Period between reset and communication enabled • During self printing <p>ESC/POS Mode Indicates whether data receive from host is enabled or disabled.</p> <p>1) DTR/DSR Communication Mode This signal indicates whether the printer is busy. SPACE indicates that the printer is ready to receive data, and MARK indicates that the printer is busy. The busy condition can be changed by using DIP SW 1-6 as follows:</p> |

| Pin No. | | Signal name | Direction | Function | | | | | | | | | | | | | | | | | | | | | | | | | | |
|---|------------|--------------------------|-----------|--|----------------|------------|--|-----|----|---|------|------|------------------------------|------|------|----------------------------|---|------|--|---|------|---|---|------|--------------------------------|---|------|--|------|------|
| 25 Pin | 9 Pin | | | | | | | | | | | | | | | | | | | | | | | | | | | | | |
| | | | | <table border="1"> <thead> <tr> <th rowspan="2">Printer status</th> <th colspan="2">DIP SW 1-6</th> </tr> <tr> <th>OFF</th> <th>ON</th> </tr> </thead> <tbody> <tr> <td>1. During the period from when the power is turned on (including resetting using the interface) to when the printer is ready to receive data.</td> <td>BUSY</td> <td>BUSY</td> </tr> <tr> <td>2. During the self printing.</td> <td>BUSY</td> <td>BUSY</td> </tr> <tr> <td>3. When the cover is open.</td> <td>-</td> <td>BUSY</td> </tr> <tr> <td>4. When the printer stops printing due to a paper-end.</td> <td>-</td> <td>BUSY</td> </tr> <tr> <td>5. During macro executing standby status.</td> <td>-</td> <td>BUSY</td> </tr> <tr> <td>6. When an error has occurred.</td> <td>-</td> <td>BUSY</td> </tr> <tr> <td>7. When the receive buffer becomes full.</td> <td>BUSY</td> <td>BUSY</td> </tr> </tbody> </table> <p>2) X-On/X-Off Communication Mode Always space, except during following conditions:</p> <ul style="list-style-type: none"> • Period between reset and communication enabled • During self printing | Printer status | DIP SW 1-6 | | OFF | ON | 1. During the period from when the power is turned on (including resetting using the interface) to when the printer is ready to receive data. | BUSY | BUSY | 2. During the self printing. | BUSY | BUSY | 3. When the cover is open. | - | BUSY | 4. When the printer stops printing due to a paper-end. | - | BUSY | 5. During macro executing standby status. | - | BUSY | 6. When an error has occurred. | - | BUSY | 7. When the receive buffer becomes full. | BUSY | BUSY |
| Printer status | DIP SW 1-6 | | | | | | | | | | | | | | | | | | | | | | | | | | | | | |
| | OFF | ON | | | | | | | | | | | | | | | | | | | | | | | | | | | | |
| 1. During the period from when the power is turned on (including resetting using the interface) to when the printer is ready to receive data. | BUSY | BUSY | | | | | | | | | | | | | | | | | | | | | | | | | | | | |
| 2. During the self printing. | BUSY | BUSY | | | | | | | | | | | | | | | | | | | | | | | | | | | | |
| 3. When the cover is open. | - | BUSY | | | | | | | | | | | | | | | | | | | | | | | | | | | | |
| 4. When the printer stops printing due to a paper-end. | - | BUSY | | | | | | | | | | | | | | | | | | | | | | | | | | | | |
| 5. During macro executing standby status. | - | BUSY | | | | | | | | | | | | | | | | | | | | | | | | | | | | |
| 6. When an error has occurred. | - | BUSY | | | | | | | | | | | | | | | | | | | | | | | | | | | | |
| 7. When the receive buffer becomes full. | BUSY | BUSY | | | | | | | | | | | | | | | | | | | | | | | | | | | | |
| 21~24 | | N/C | | Not used | | | | | | | | | | | | | | | | | | | | | | | | | | |
| 25 | | $\overline{\text{INIT}}$ | IN | Status of this signal is not checked. | | | | | | | | | | | | | | | | | | | | | | | | | | |

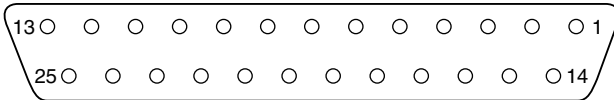

D-sub 25 Pin

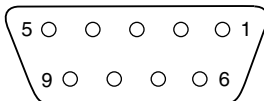

D-sub 9 Pin

D-2. Cable Connections

The followings are a recommended interface cable connections.

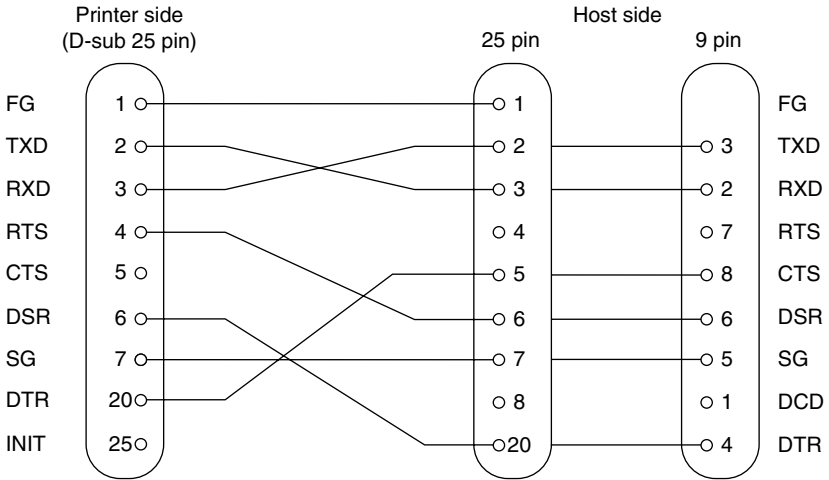

Note: Use shielded wire less than 3m in length.

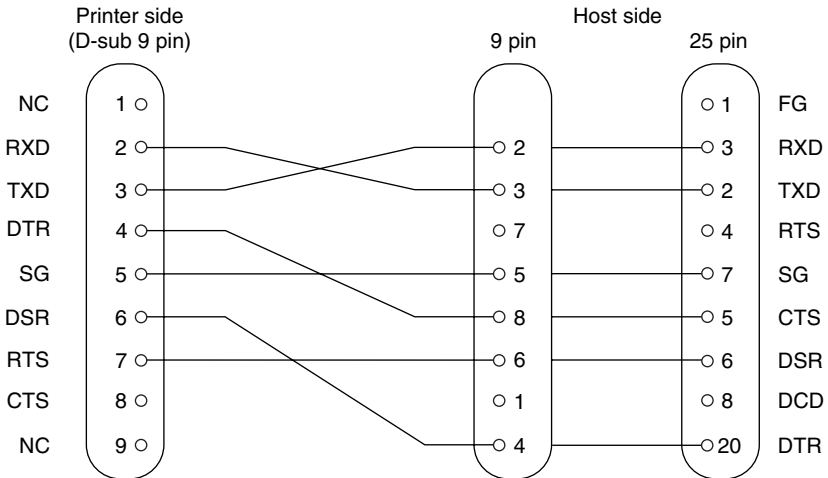

Note: Use shielded wire less than 3m in length.

D-3. Electrical Characteristics

| Voltage | Data signal | Control signal | Binary status |
|-------------|-------------|----------------|---------------|
| -3V to -15V | Mark | OFF | 1 |
| +3V to +15V | Space | ON | 0 |

Appendix E: USB, Ethernet and Wireless LAN Interface

E-1. USB Interface Specifications

1. General Specification: Conforms to USB 2.0 Specifications
2. Communication Speed: USB Full Speed Mode (12 Mbps)
3. Communication Method: USB Bulk Transmission Mode
4. Power Specifications: USB Self-power Function
5. Connector: USB Up-Stream Port Connector (USB Type-B)

E-2. Ethernet Interface Specifications

1. General Specification: Conforms to IEEE802.3
2. Communication Media: 10 Base-T (Connectable to 100 Base-T)
3. Communication Speed: 10 Mbps
4. Protocol: TCP/IP
5. TCP/IP detail: ARP, RARP, BOOTP, DHCP, LPR, #9100, IPP, POP3, HTTP, TELNET, SMTP, SNMP
6. Connector: RJ-45 (8-pin modular)

E-3. Wireless LAN Interface Specifications

1. General Specification: Conforms to IEEE802.11b
2. Communication Media: 2.4 GHz DSSS wireless CF card
3. Communication Speed: 1M/2M/5.5M/11Mbps AUTO Full-Back
4. Protocol: TCP/IP
5. TCP/IP detail: ARP, RARP, BOOTP, DHCP, LPR, #9100, IPP, POP3, HTTP, TELNET, SMTP, SNMP, FTP
6. Operating Channels: North America : 1-11 ch
Japan : 1-14 ch
Europe : 1-13 ch

Appendix F: Buzzer Driver Circuit

This printer is equipped with a circuit for driving the buzzer. A 6-pin modular connector for connection of the buzzer is located on the back of the printer. To connect to the drive circuit, connect the buzzer to the modular connector using a cable supplied by you like that one shown in the figure below.

⚠ Caution

Never connect any other type of plug to the buzzer connector.

Modular plug

Modular plug: MOLEX 90075-0007,
AMP641337, or JAPAN BURNDY B-66-4

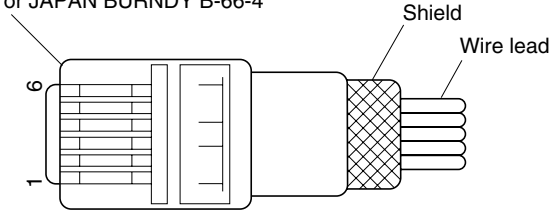

| Pin No. | Signal name | Function | I/O direction |
|---------|-------------|----------------|---------------|
| 1 | FG | Frame ground | — |
| 2 | DRV1 | Drive signal 1 | OUT |
| 3 | +24V | Drive power | OUT |
| 4 | +24V | Drive power | OUT |
| 5 | N.C. | Not connected | — |
| 6 | N.C. | Not connected | — |

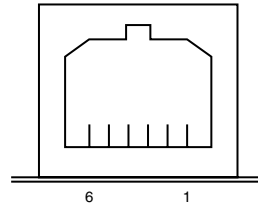

<Viewed from Connector Surface>

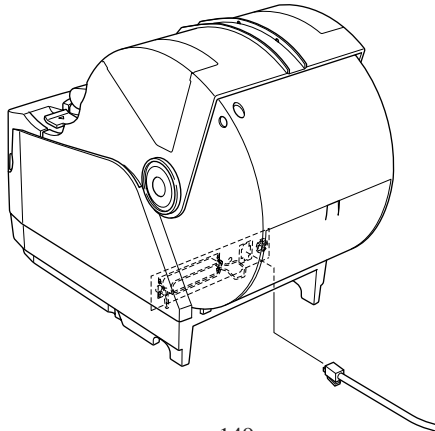

Drive circuit

The recommended drive unit is shown below.

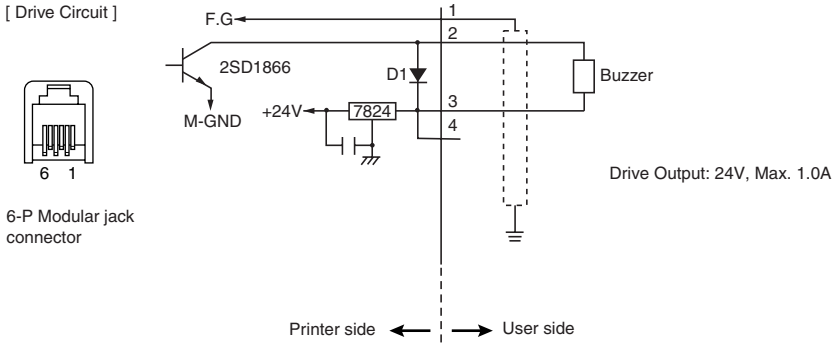

Reference
2SD1866 Circuit Configuration

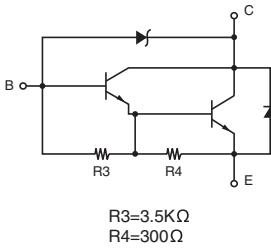

Note:

- 1) Pin 1 must be shield drain wire connected to buzzer device frame ground.
- 2) For continuous driving, Maximum drive output is 0.1A.
- 3) Absolute maximum ratings for diodes D1 ($T_a = 25^\circ\text{C}$) is:
Average Rectified Current $I_o = 1\text{A}$
- 4) Absolute maximum rating for transistors 2SD1866 ($T_a = 25^\circ\text{C}$) is:
Collector current $I_c = 2\text{A}$

Appendix G: Memory Switch Settings

Each memory switch is stored in EEPROM. For details on the functions and settings of memory switches, see the separate Specification Manual.

The table below shows the factory settings for the memory switches.

| Memory Switch | Hexadecimal Code |
|---------------|-----------------------------------|
| 0 | 0000 |
| 1 | 0000 |
| 2 | 0000 |
| 3 | 0000 |
| 4 | 0001(TSP1043) or 0000(TSP1045) |
| 8 | 0000 |
| 9 | 0000 |

CAUTION

Changing the memory switch settings can cause the printer to fail to operate correctly.

WEEE Statement

En

In the European Union, this label indicates that this product should not be disposed of with household waste. It should be deposited at an appropriate facility to enable recovery and recycling in accordance with legislation under the WEEE Directive (Directive 2002/96/EC).

Ge

In der Europäischen Union dient dieses Symbol als Hinweis dieses Produkt nicht im normalen Hausmüll zu entsorgen. Die Entsorgung sollte als getrennte Sammlung über geeignete Einrichtungen/Sammelstellen zum Recycling nach WEEE-Vorschrift (EU-Richtlinie 2002/96/EC) erfolgen.

Fr

Dans l'union europeenne (U.E.), cette etiquette indique que ce produit ne doit pas etre jete avec les dechets menagers. Il doit etre depose dans un container approprie permettant la recuperation et le recyclage en accord avec les directives WEEE de la legislation europeennes (Directive 2002/96/EC).

It

Nell unione europea, la presente etichetta indica che il prodotto non deve essere gettato nei rifiuti, bensì riciclato attraverso gli appositi contenitori secondo la legislazione sotto la Direttiva WEEE (Direttiva 2002/96/EC).

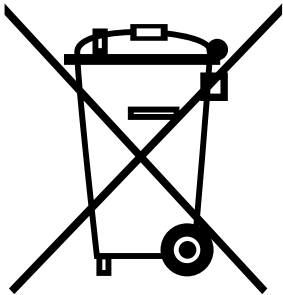



**ELECTRONIC PRODUCTS DIVISION
STAR MICRONICS CO., LTD.**

536 Nanatsusinya, Shimizu-ku, Shizuoka,
424-0066 Japan
Tel: 0543-47-0112, Fax: 0543-48-5013

Please access the following URL

<http://www.star-m.jp/eng/dll/dl02.htm>

for the latest revision of the manual.

**OVERSEAS SUBSIDIARY COMPANIES
STAR MICRONICS AMERICA, INC.**

1150 King Georges Post Road, Edison, NJ 08837-3729 U.S.A.
Tel: 732-623-5555, Fax: 732-623-5590

STAR MICRONICS U.K. LTD.

Star House, Peregrine Business Park, Gomm Road,
High Wycombe, Bucks, HP13 7DL, U.K.
Tel: 01494-471111, Fax: 01494-473333