

G60



User Guide

Barco NV

Beneluxpark 21, 8500 Kortrijk, Belgium
www.barco.com/en/support
www.barco.com

Registered office: Barco NV

President Kennedypark 35, 8500 Kortrijk, Belgium
www.barco.com/en/support
www.barco.com

Copyright ©

All rights reserved. No part of this document may be copied, reproduced or translated. It shall not otherwise be recorded, transmitted or stored in a retrieval system without the prior written consent of Barco.

Changes

Barco provides this manual 'as is' without warranty of any kind, either expressed or implied, including but not limited to the implied warranties or merchantability and fitness for a particular purpose. Barco may make improvements and/or changes to the product(s) and/or the program(s) described in this publication at any time without notice.

This publication could contain technical inaccuracies or typographical errors. Changes are periodically made to the information in this publication; these changes are incorporated in new editions of this publication.

The latest edition of Barco manuals can be downloaded from the Barco web site www.barco.com or from the secured Barco web site <https://www.barco.com/en/signin>.

Trademarks

Brand and product names mentioned in this manual may be trademarks, registered trademarks or copyrights of their respective holders. All brand and product names mentioned in this manual serve as comments or examples and are not to be understood as advertising for the products or their manufacturers.

Trademarks

- Crestron is a registered trademark of Crestron Electronics, Inc. of the United States.
- Extron is a registered trademark of Extron Electronics, Inc. of the United States.
- AMX is a registered trademark of AMX LLC of the United States.
- PJLink applied for trademark and logo registration in Japan, the United States of America, and other countries by JBMA.

Guarantee and Compensation

Barco provides a guarantee relating to perfect manufacturing as part of the legally stipulated terms of guarantee. On receipt, the purchaser must immediately inspect all delivered goods for damage incurred during transport, as well as for material and manufacturing faults Barco must be informed immediately in writing of any complaints.

The period of guarantee begins on the date of transfer of risks, in the case of special systems and software on the date of commissioning, at latest 30 days after the transfer of risks. In the event of justified notice of complaint, Barco can repair the fault or provide a replacement at its own discretion within an appropriate period. If this measure proves to be impossible or unsuccessful, the purchaser can demand a reduction in the purchase price or cancellation of the contract. All other claims, in particular those relating to compensation for direct or indirect damage, and also damage attributed to the operation of software as well as to other services provided by Barco, being a component of the system or independent service, will be deemed invalid provided the damage is not proven to be attributed to the absence of properties guaranteed in writing or due to the intent or gross negligence or part of Barco.

If the purchaser or a third party carries out modifications or repairs on goods delivered by Barco, or if the goods are handled incorrectly, in particular if the systems are operated incorrectly or if, after the transfer of risks, the goods are subject to influences not agreed upon in the contract, all guarantee claims of the purchaser will be rendered invalid. Not included in the guarantee coverage are system failures which are attributed to programs or special electronic circuitry provided by the purchaser, e.g. interfaces. Normal wear as well as normal maintenance are not subject to the guarantee provided by Barco either.

The environmental conditions as well as the servicing and maintenance regulations specified in this manual must be complied with by the customer.

Federal Communications Commission (FCC Statement)

This equipment has been tested and found to comply with the limits for a class A digital device, pursuant to Part 15 of the FCC rules. These limits are designed to provide reasonable protection against harmful interference when the equipment is operated in a commercial environment. This equipment generates, uses, and can radiate radio frequency energy and, if not installed and used in accordance with the instruction manual, may cause harmful interference to radio communications. Operation of this equipment in a residential

area may cause harmful interference, in which case the user will be responsible for correcting any interference at his own expense

Changes or modifications not expressly approved by the party responsible for compliance could void the user's authority to operate the equipment

FCC responsible: Barco Inc.
3059 Premiere Parkway Suite 400
30097 Duluth GA, United States
Tel: +1 678 475 8000

Patent protection

Please refer to www.barco.com/about-barco/legal/patents

EMC notices

EN55032/CISPR32 Class A MME (MultiMedia Equipment)

Warning : This equipment is compliant with Class A of CISPR 32. In a residential environment this equipment may cause radio interference.

GB/T 9254 Class A ITE (Information Technology Equipment)

Warning : This is a class A product. In a domestic environment this product may cause radio interference in which case the user may be required to take adequate measures.

BSMI Taiwan Class A statement:

警告使用者：此為甲類資訊技術設備，於居住環境中使用，可能會造成射頻擾動，在此情況下，使用者會被要求採取某些適當的對策。

Table of contents

1 Safety	7
1.1 General considerations	8
1.2 Important safety instructions	10
1.3 Product safety labels	13
1.4 Risk Group 3 Safety	14
1.4.1 General considerations	14
1.4.2 High Brightness precautions: Hazard Distance (HD)	15
1.4.3 HD for fully enclosed projection systems	17
2 Product overview	19
2.1 Main unit	20
2.2 Input/Output (I/O) Panel	21
2.3 Control panel	22
2.4 Remote Control Unit (RCU)	23
3 Powering On/Off the projector	25
3.1 Powering On the projector	26
3.2 Powering Off the Projector	26
4 User controls	29
4.1 On-Screen Display Menus	30
4.2 Picture Menu	31
4.3 Screen Menu	34
4.4 Settings Menu	38
4.5 Light Source Menu	39
4.6 Options Menu	40
4.7 3D Menu	42
4.8 Communications Menu	43
4.9 Controlling the projector over network	44
4.10 Using the web control center	45
4.11 Using RS232 command by Telnet	47
5 Troubleshooting	49
5.1 LED indication chart	50
5.2 Projector Problems	51
A Specifications	53
A.1 Product specification of the G60-W7	54
A.2 Product specification of the G60-W8	55
A.3 Product specification of the G60-W10	56
A.4 Compatibility modes	57

A.5	Dimensions of the G60	61
A.6	Ceiling mount	62
B	Environmental information	65
B.1	China RoHS compliance.....	66
B.2	Taiwan RoHS compliance	67
B.3	Turkey RoHS compliance	68
B.4	Disposal information.....	68
B.5	Production address.....	69
B.6	Contact information	69
B.7	Download Product Manual	69
	Glossary.....	71
	Index.....	73

Safety

1

About this document

Read this document attentively. It contains important information to prevent personal injury while installing and using the G60 projector. Furthermore, it includes several cautions to prevent damage to the G60 projector. Ensure that you understand and follow all safety guidelines, safety instructions and warnings mentioned in this chapter before installing the G60 projector.

Clarification of the term “G60” used in this document

When referring in this document to the term “G60” means that the content is applicable for following Barco products:

- G60-W7, G60-W8, G60-W10

Model certification name

- G60



Barco provides a guarantee relating to perfect manufacturing as part of the legally stipulated terms of guarantee. Observing the specification mentioned in this chapter is critical for projector performance. Neglecting this can result in loss of warranty.

Overview

- General considerations
- Important safety instructions
- Product safety labels
- Risk Group 3 Safety

1.1 General considerations

General safety instructions

- Before operating this equipment please read this manual thoroughly and retain it for future reference.
- Installation and preliminary adjustments should be performed by qualified Barco personnel or by authorized Barco service dealers.
- All warnings on the projector and in the documentation manuals should be adhered to.
- All instructions for operating and use of this equipment must be followed precisely.
- All local installation codes should be adhered to.
- IEC 60825-1: 2014 Class 1 RG2
- IEC 62471-5:2015 RG2
- Additional instructions to supervise children, no staring, and not use optical aids.
- Additional instructions to install above the reach of children.
- Notice is given to supervise children and to never allow them to stare into the projector beam at any distance from the projector.
- Notice is given to use caution when using the remote control for starting the projector while in front of the projection lens.
- Notice is given to the user to avoid the use of optical aids such as binoculars or telescopes inside the beam.
- “As with any bright light source, do not stare into the beam, RG2 IEC 62471-5:2015”.
- “WARNING: MOUNT ABOVE THE HEADS OF CHILDREN. The use of a ceiling mount is recommended with this product to place it above the eyes of children.

Notice on safety

This equipment is built in accordance with the requirements of the international safety standards IEC60950-1, EN60950-1, UL60950-1 and CAN/CSA C22.2 No.60950-1, which are the safety standards of information technology equipment including electrical business equipment. These safety standards impose important requirements on the use of safety critical components, materials and insulation, in order to protect the user or operator against risk of electric shock and energy hazard and having access to live parts. Safety standards also impose limits to the internal and external temperature rises, radiation levels, mechanical stability and strength, enclosure construction and protection against the risk of fire. Simulated single fault condition testing ensures the safety of the equipment to the user even when the equipment's normal operation fails.

Laser safety precautions for G60-W7 series

This product is classified as Class 1 Laser Product-Risk Group 2 of IEC 60825-1 : 2014 and Class 3R Laser product of IEC 60825-1:2007, complying with 21 CFR 1040.10 and 1040.11 except for deviations pursuant to Laser Notice No.50, dated June 24, 2007.

To ensure safety operation, read all laser safety precautions before installing and operating the projector.

- Class 3R Laser product. Do NOT deliberately look into or stare into the beam, which can cause injury to the retina in the back of the eye.
- This projector uses extremely high brightness laser. Never attempt to look directly into the lens or into the light beam. The bright light may result in permanent eye damage. (Risk Group 2 of IEC 62471-5:2015).
- When turning on the projector, make sure no one within projection range is looking into the lens.
- Keep any reflective objects out of the light path of the projector. Glass and shiny surfaces can reflect the light beam from the lens as the light path is extensive, and the reflective beam can cause unpredictable incident such as fire hazards or eye injuries.
- Any operation or adjustment not specifically instructed by the user's guide creates the risk of hazardous laser radiation exposure.
- Do not open or disassemble the projector as this may cause damage by the exposure of laser radiation.
- Failure to follow the control, adjustment or operation procedures may cause damage by the exposure of laser radiation.

Laser safety precautions for G60-W8 series

This product is classified as CLASS 1 LASER PRODUCT - RISK GROUP 2 of IEC 60825-1 : 2014 and also complies with 21 CFR 1040.10 and 1040.11 except for conformance as a Risk Group 2 LIP as defined in IEC 62471-5:Ed. 1.0. For more information see Laser Notice No. 57, dated May 8, 2019.

According to IEC 60825-1:2014 and IEC 62471-5:2015, this projector may be CLASS 1 LASER PRODUCT - RISK GROUP 2 product.

To ensure safety operation, read all laser safety precautions before installing and operating the projector.

- This projector uses extremely high brightness laser. Never attempt to look directly into the lens or into the light beam. The bright light may result in permanent eye damage. (Risk Group 2 of IEC 62471-5:2015).
- No direct exposure to the beam shall be permitted.
- Possibly hazardous optical radiation emitted from this product.
- This projector has a built-in Class 4 laser module. Never attempt to disassemble or modify the laser module.
- Any operation or adjustment not specifically instructed in the User manual creates the risk of hazardous laser radiation exposure.
- Do not stare into beam when the projector is on. When turning on the projector, make sure no one within projection range is looking into the lens.
- Follow the control, adjustment, or operation procedures to avoid damage or injury from exposure of laser radiation.
- The instructions for the assembly, operation, and maintenance include clear warnings concerning precautions to avoid possible exposure to hazardous laser radiation.

Laser safety precautions for G60-W10 series

This product is classified as Class 1 Laser Product-Risk Group 2 (RG2) of IEC 60825-1: 2014 and Class 3R Laser product of IEC 60825-1:2007, complying with 21 CFR 1040.10 and 1040.11 except for deviations pursuant to Laser Notice No.50, dated June 24, 2007.

When installed with G LENS (2.90 - 5.50 : 1) lens (throw ratio 2.90-5.50), this projector may become Class 1 Laser Product-Risk Group 3 (RG3) according to IEC 60825-1:2014, IEC 62471-5: 2015, and also make a variance approvals under 21 CFR 1010.4 for RG3 LIP according to Classification and Requirements for Laser Illuminated Projectors (LIPs) (Laser Notice No. 57).

To ensure safety operation, read all laser safety precautions before installing and operating the projector.

- This projector uses extremely high brightness laser. Do not stare into the direct light beam, as the extremely high brightness may cause permanent eye damage. (Risk Group 2 of IEC 62471-5:2015).
- No direct exposure to the beam shall be permitted. (Risk Group 3 of IEC 62471-5:2015).
- This product is not for household use.
- Possibly hazardous optical radiation emitted from this product.
- This projector has a built-in Class 4 laser module. Never attempt to disassemble or modify the laser module.
- Any operation or adjustment not specifically instructed in the User manual creates the risk of hazardous laser radiation exposure.
- Do not stare into beam when the projector is on. When turning on the projector, make sure no one within projection range is looking into the lens.
- Follow the control, adjustment, or operation procedures to avoid damage or injury from exposure of laser radiation.
- The instructions for the assembly, operation, and maintenance include clear warnings concerning precautions to avoid possible exposure to hazardous laser radiation.

Light Intensity Hazard Distance for G60-W10 series

This projector may become Class 1 Laser Product-Risk Group 3 (RG3) when installed with G LENS (2.90 - 5.50 : 1) lens (throw ratio 2.90-5.50). Permanent eye injury is possible when exposed to the high intensity light beam within the hazard distance (HD).

Projection Lens	Throw Ratio	Classification and Requirements for Laser Illuminated Projectors (LIPs)	
		World wide except US (IEC 60825-1:2014)	World wide include US (IEC 62471-5: 2015)
G LENS (2.90 - 5.50 : 1)	2.90-5.50	CLASS 1	RISK GROUP 3 HD: 3.0 meters

Follow the precautions to avoid light intensity hazard.

- NEVER look into the lens! High intensity light beam.
- Permanent eye injury is possible when exposed to the high intensity light beam within the hazard distance.
- Operators shall control access to the light beam within the hazard distance or install the product at a height that will prevent eye exposure within the hazard distance.
- Do not place any reflective objects in the light path of the projector.

User definition

Throughout this manual, the term SERVICE PERSONNEL refers to Barco authorized persons having appropriate technical training and experience necessary to be knowledgeable of potential hazards to which they are exposed (including, but not limited to HIGH VOLTAGE ELECTRIC and ELECTRONIC CIRCUITRY and HIGH BRIGHTNESS PROJECTORS) in performing a task, and of measures to minimize the potential risk to themselves or other persons. Only Barco authorized SERVICE PERSONNEL, knowledgeable of such risks, are allowed to perform service functions inside the product enclosure. The term USER and OPERATOR refers to any person other than SERVICE PERSONNEL. When installing an interchangeable lens with a throw ratio that make the projector become RG3, refer to chapter "Risk Group 3 Safety", page 9. Such combination of projector and lens are intended for professional use only, and are not intended for consumer use.

FOR PROFESSIONAL USE ONLY means installation can only be carried out by Barco AUTHORIZED PERSONNEL familiar with potential hazards associated with high intensity light beams.

1.2 Important safety instructions

To prevent the risk of electrical shock

- This product should be operated from a mono phase AC power source.
- This apparatus must be grounded (earthed) via the supplied 3 conductor AC power cable. If none of the supplied power cables are the correct one, consult your dealer. If you are unable to insert the plug into the outlet, contact your electrician to replace your obsolete outlet. Do not defeat the purpose of the grounding-type plug.
- Do not allow anything to rest on the power cord. Do not locate this product where persons will walk on the cord. To disconnect the cord, pull it out by the plug. Never pull the cord itself.
- Use only the power cord supplied with your device. While appearing to be similar, other power cords have not been safety tested at the factory and may not be used to power the device. For a replacement power cord, contact your dealer.
- Do not operate the projector with a damaged cord. Replace the cord.
- Do not operate the projector if the projector has been dropped or damaged until it has been examined and approved for operation by a qualified service technician. Position the cord so that it will not be tripped over, pulled, or contact hot surfaces.
- If an extension cord is necessary, a cord with a current rating at least equal to that of the projector should be used. A cord rated for less amperage than the projector may overheat.
- Never push objects of any kind into this product through cabinet slots as they may touch dangerous voltage points or short out parts that could result in a risk of fire or electrical shock.
- Do not expose this projector to rain or moisture.
- Do not immerse or expose this projector in water or other liquids.
- Do not spill liquid of any kind on this projector.
- Should any liquid or solid object fall into the cabinet, unplug the set and have it checked by qualified service personnel before resuming operations.
- Do not disassemble this projector, always take it to an authorized trained service person when service or repair work is required.
- Do not use an accessory attachment which is not recommended by the manufacturer.
- Lightning - For added protection for this video product during a lightning storm, or when it is left unattended and unused for long periods of time, unplug it from the wall outlet. This will prevent damage to the device due to lightning and AC power-line surges.

To prevent personal injury

- To prevent injury and physical damage, always read this manual and all labels on the system before connecting to the wall outlet or adjusting the projector.

- To prevent injury, take note of the weight of the projector.
- To prevent injury, ensure that the lens and all covers are correctly installed. See installation procedures.
- Warning: high intensity light beam. NEVER look into the lens ! High luminance could result in damage to the eye.
- Warning: extremely high brightness laser: This projector uses extremely high brightness laser. Never attempt to look directly into the lens or at the laser.
- Before attempting to remove any of the projector's covers, you must turn off the projector and disconnect from the wall outlet.
- When required to switch off the projector, to access parts inside, always disconnect the power cord from the power net.
- The power input at the projector side is considered as the disconnect device. When required to switch off the projector, to access parts inside, always disconnect the power cord at the projector side. In case the power input at the projector side is not accessible (e.g. ceiling mount), the socket outlet supplying the projector shall be installed nearby the projector and be easily accessible, or a readily accessible general disconnect device shall be incorporated in the fixed wiring.
- Do not place this equipment on an unstable cart, stand, or table. The product may fall, causing serious damage to it and possible injury to the user.
- It is hazardous to operate without lens or shield. Lenses, shields or ultra violet screens shall be changed if they have become visibly damaged to such an extent that their effectiveness is impaired. For example by cracks or deep scratches.
- Exposure to UV radiation: Some medications are known to make individuals extra sensitive to UV radiation. The American Conference of Governmental Industrial Hygienists (ACGIH) recommends occupational UV exposure for an-8 hour day to be less than 0,1 micro-watts per square centimeters of effective UV radiation. An evaluation of the workplace is advised to assure employees are not exposed to cumulative radiation levels exceeding these government guidelines. The exposer of this UV radiation is allowed for only 1 hour per day for maintenance and service persons.

To prevent fire hazard

- Do not place flammable or combustible materials near the projector!
- Barco large screen projection products are designed and manufactured to meet the most stringent safety regulations. This projector radiates heat on its external surfaces and from ventilation ducts during normal operation, which is both normal and safe. Exposing flammable or combustible materials into close proximity of this projector could result in the spontaneous ignition of that material, resulting in a fire. For this reason, it is absolutely necessary to leave an "exclusion zone" around all external surfaces of the projector whereby no flammable or combustible materials are present. The exclusion zone must be not less than 100 cm (39.4") for all DLP projectors. The exclusion zone on the lens side must be at least 5 m. Do not cover the projector or the lens with any material while the projector is in operation. Keep flammable and combustible materials away from the projector at all times. Mount the projector in a well-ventilated area away from sources of ignition and out of direct sun light. Never expose the projector to rain or moisture. In the event of fire, use sand, CO2 or dry powder fire extinguishers. Never use water on an electrical fire. Always have service performed on this projector by authorized Barco service personnel. Always insist on genuine Barco replacement parts. Never use non- Barco replacement parts as they may degrade the safety of this projector.
- Slots and openings in this equipment are provided for ventilation. To ensure reliable operation of the projector and to protect it from overheating, these openings must not be blocked or covered. The openings should never be blocked by placing the projector too close to walls, or other similar surface. This projector should never be placed near or over a radiator or heat register. This projector should not be placed in a built-in installation or enclosure unless proper ventilation is provided.
- Projection rooms must be well ventilated or cooled in order to avoid build up of heat.
- Let the projector cool down completely before storing. Remove cord from the projector when storing.

To prevent projector damage

- Always remove lens cap before switching on the projector. If the lens cap is not removed, it may melt due to the high energy light emitted through the lens. Melting the lens cap may permanently damage the surface of the projection lens.
- The air filters of the projector must be cleaned or replaced on a regular basis. Cleaning the booth area would be monthly minimum. Neglecting this could result in disrupting the air flow inside the projector, causing overheating. Overheating may lead to the projector shutting down during operation.
- The projector must always be installed in a manner which ensures free flow of air into its air inlets and unimpeded evacuation of the hot air from its cooling system.

- If more than one projector is installed in a common projection booth, the exhaust air flow requirements are valid for EACH individual projector system. Note that inadequate air extraction or cooling will result in decreased life expectancy of the projector as a whole as well as causing premature failure of the lasers.
- In order to ensure that correct airflow is maintained, and that the projector complies with Electromagnetic Compatibility (EMC) requirements, it should always be operated with all of its covers in place.
- Slots and openings in the cabinet are provided for ventilation. To ensure reliable operation of the product and to protect it from overheating, these openings must not be blocked or covered. The openings should never be blocked by placing the product on a bed, sofa, rug, or other similar surface. This product should never be placed near or over a radiator or heat register. The device should not be placed in a built-in installation or enclosure unless proper ventilation is provided.
- Ensure that nothing can be spilled on, or dropped inside the projector. If this does happen, switch off and unplug the mains supply immediately. Do not operate the projector again until it has been checked by qualified service personnel.
- Do not block the projector cooling fans or free air movement around the projector.
- Do not use this equipment near water.
- Special care for Laser Beams: Special care should be used when DLP projectors are used in the same room as high power laser equipment. Direct or indirect hitting of a laser beam on to the lens can severely damage the Digital Mirror Devices™ in which case there is a loss of warranty.
- Never place the projector in direct sun light. Sun light on the lens can severely damage the Digital Mirror Devices™ in which case there is a loss of warranty.
- Save the original shipping carton and packing material. They will come in handy if you ever have to ship your equipment. For maximum protection, repack your set as it was originally packed at the factory.
- Unplug this product from the wall outlet before cleaning. Do not use liquid cleaners or aerosol cleaners. Use a damp cloth for cleaning. Never use strong solvents, such as thinner or benzene, or abrasive cleaners, since these will damage the cabinet. Stubborn stains may be removed with a cloth lightly dampened with mild detergent solution.
- To ensure the highest optical performance and resolution, the projection lenses are specially treated with an anti-reflective coating, therefore, avoid touching the lens. To remove dust on the lens, use a soft dry cloth. Do not use a damp cloth, detergent solution, or thinner.
- Rated operating ambient temperature: $t_a = 5\text{ °C}$ (41 °F) to 40 °C (104 °F).
- Rated operating humidity: 10% RH to 85% RH (non-condensing). This projector can be set to any angle within 360° range.
- Allowing proper space around the projector is critical for proper air circulation and cooling of the unit. The dimensions shown here indicate the minimum space required.

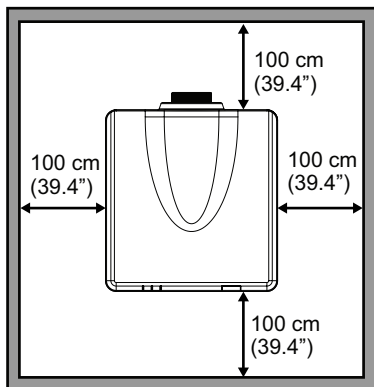
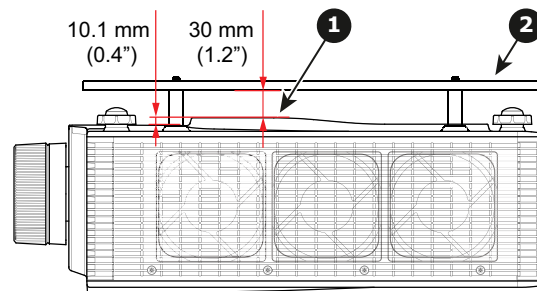

Image 1-1



- 1 Bottom intake vents.
- 2 Ceiling mount plate.

- For ceiling mounted installations, make sure to leave 30 mm (1.2") between the ceiling mount and the bottom intake vents of the projector.

To prevent battery explosion

- Danger of explosion if battery is incorrectly installed.
- Replace only with the same or equivalent type recommended by the manufacturer.
- For disposal of used batteries, always consult federal, state, local and provincial hazardous waste disposal rules and regulations to ensure proper disposal.

On servicing



- Do not attempt to service this product yourself, as opening or removing covers may expose you to dangerous voltage potentials and risk of electric shock.
- Refer all servicing to qualified service personnel.
- Attempts to alter the factory-set internal controls or to change other control settings not specially discussed in this manual can lead to permanent damage to the projector and cancellation of the warranty.
- Remove all power from the projector and refer servicing to qualified service technicians under the following conditions:
 - When the power cord or plug is damaged or frayed.
 - If liquid has been spilled into the equipment.
 - If the product has been exposed to rain or water.
 - If the product does not operate normally when the operating instructions are followed. Adjust only those controls that are covered by the operating instructions since improper adjustment of the other controls may result in damage and will often require extensive work by a qualified technician to restore the product to normal operation.
 - If the product has been dropped or the cabinet has been damaged.
 - If the product exhibits a distinct change in performance, indicating a need for service.
- Replacement parts: When replacement parts are required, be sure the service technician has used original Barco replacement parts or authorized replacement parts which have the same characteristics as the Barco original part. Unauthorized substitutions may result in degraded performance and reliability, fire, electric shock or other hazards. Unauthorized substitutions may void warranty.
- Safety check: Upon completion of any service or repairs to this projector, ask the service technician to perform safety checks to determine that the product is in proper operating condition.

Safety Data Sheets for Hazardous Chemicals

For safe handling information on chemical products, consult the Safety Data Sheet (SDS). SDSs are available upon request via safetydatasheets@barco.com.

1.3 Product safety labels

Light beam related safety labels for G60-W7 series

Label image	Label description
 <p>Laser Aperture Do not look into the Lens Ouverture Rayonnement Laser Ne regardez pas dans la lentille 避免出入口，不要看鏡頭 避免出入口，不要看鏡頭</p>	<p>Risk Group 2 of IEC60825-1:2014 and Class 3R Laser product of IEC 60825-1:2007. Do not look into the laser light. The extremely high brightness may cause permanent eye damage.</p>
 <p>IEC 60825-1:2007 LASER RADIATION - AVOID DIRECT EYE EXPOSURE - CLASS 3R LASER PRODUCT Maximum Power: 440-460 mW (Max. Pulse energy: 0.52 mJ) / Pulse duration: 1.06 ms IEC 60825-1:2014 CLASS 1 LASER PRODUCT / RISK GROUP 2 WARNING: Possibly hazardous optical radiation emitted from this product. Do not stare into the beam. May be harmful to the eyes. IEC 60825-1:2007 激光辐射，避免直视激光光束 功率：440-460 mW (最大脉冲能量：0.52 mJ) / 脉冲持续时间：1.06 ms IEC 60825-1:2014 1类激光产品 / 风险组2 警告：本产品可能发出有害的光学辐射。不要直视激光束。可能会对眼睛造成永久性伤害。 IEC 60825-1:2007 激光辐射，避免直视激光光束 功率：440-460 mW (最大脉冲能量：0.52 mJ) / 脉冲持续时间：1.06 ms IEC 60825-1:2014 1类激光产品 / 风险组2 警告：本产品可能发出有害的光学辐射。不要直视激光束。可能会对眼睛造成永久性伤害。 IEC 60825-1:2007 RAYONNEMENT LASER - ÉVITEZ TOUTE EXPOSITION DIRECTE DES YEUX - PRODUIT LASER DE CLASSE 3R Longueur d'onde: 440-460 nm / Max. Impulsion d'énergie: 0.52 mJ / Durée Impulsion: 1.06 ms IEC 60825-1:2014 PRODUIT LASER DE CLASSE 1 / GROUPE A RISQUE 2 RAYONNEMENT LASER - ÉVITEZ TOUTE EXPOSITION DIRECTE DES YEUX - Produit Laser de Classe 1 / Groupe à Risque 2 Ne pas regarder dans la faisceau. Peut être dangereux pour les yeux.</p>	<p>This product is classified as Class 1 Laser Product-Risk Group 2 of IEC 60825-1 : 2014 and Class 3R Laser product of IEC 60825-1:2007, complying with 21 CFR 1040.10 and 1040.11 except for deviations pursuant to Laser Notice No.50, dated June 24, 2007.</p>

Light beam related safety labels for G60-W8 series

Label image

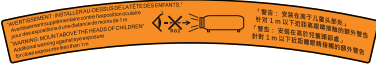

Label description

Risk Group 2, IEC60825-1:2014. Do not look into the laser light. The extremely high brightness may cause permanent eye damage.

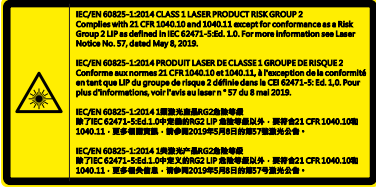

This product is classified as Class 1 Laser Product-Risk Group 2 of IEC 60825-1:2014 and also complies with 21 CFR 1040.10 and 1040.11 as a Risk Group 2, LIP (Laser Illuminated Projector) as defined in IEC 62471-5:Ed.1.0. For more information see Laser Notice No. 507, dated May 8, 2019.

Light beam related safety labels for G60-W10 series

Label image

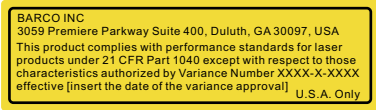

Label description

FDA laser variance (US projectors only)



This product is classified as Class 1 Laser Product-Risk Group 2 of IEC/EN 60825-1:2014 and Class 3R Laser product of IEC/EN 60825-1:2007, complying with 21 CFR 1040.10 and 1040.11 except for deviations pursuant to Laser Notice No.50, dated June 24, 2007.

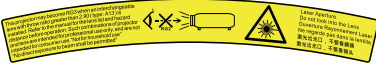

This projector may become Risk Group 3 product when an interchangeable lens with throw ratio greater than 2.9 (G lens - Ultra Long Zoom) is installed. Refer to the manual for the lens list and hazard distance before operation. Such combinations of projector and lens are intended for professional use only, and are not intended for consumer use.

Not for household use.

No direct exposure to beam shall be permitted, which can cause injury to the retina in the back of the eye.

1.4 Risk Group 3 Safety

1.4.1 General considerations

Notice on optical radiation from G60 Projector when it becomes Risk Group 3.

- For RG3, no direct exposure to the beam shall be permitted. For RG3, operators shall control access to the beam within the hazard distance or install the product at a height that will prevent eye exposure within the hazard distance.
- This projector has one or several built-in Class 4 laser clusters. Disassembly or modification is very dangerous and should never be attempted.
- Any operation or adjustment not specifically instructed by the user's guide creates the risk of hazardous laser radiation exposure.
- Do not open or disassemble the projector as this may cause damage by the exposure of laser radiation.

FOR PROFESSIONAL USE ONLY means installation can only be carried out by Barco AUTHORIZED PERSONNEL familiar with potential hazards associated with high intensity light beams.



WARNING: No direct exposure to the beam within the hazard distance shall be permitted, RG3 (Risk Group 3) IEC EN 62471-5:2015



CAUTION: Use of controls or adjustments or performance of procedures other than those specified herein may result in hazardous radiation exposure.

1.4.2 High Brightness precautions: Hazard Distance (HD)

HD



Hazard Distance (HD) is the distance measured from the projection lens at which the intensity or the energy per surface unit becomes lower than the applicable exposure limit on the cornea or on the skin. The light beam is considered (to be) unsafe for exposure if the distance from a person to the light source is less than the HD.

Restriction Zone (RZ) based on the HD

The HD depends on the amount of lumens produced by the projector and the type of lens installed. See chapter "General considerations", page 8.

To protect untrained end users (as cinema visitors, spectators) the installation shall comply with the following installation requirements: Operators shall control access to the beam within the hazard distance or install the product at the height that will prevent spectators' eyes from being in the hazard distance. Radiation levels in excess of the limits will not be permitted at any point less than 2.0 meter (SH) above any surface upon which persons other than operators, performers, or employees are permitted to stand or less than 1.0 meter (SW) lateral separation from any place where such persons are permitted to be. In environments where unrestrained behavior is reasonably foreseeable, the minimum separation height should be greater than or equal to 3.0 meter to prevent potential exposure, for example by an individual sitting on another individual's shoulders, within the HD.

These values are minimum values and are based on the guidance provided in IEC 62471-5:2015 section 6.6.3.5.

The installer and user must understand the risk and apply protective measures based upon the hazard distance as indicated on the label and in the user information. Installation method, separation height, barriers, detection system or other applicable control measure shall prevent hazardous eye access to the radiation within the hazard distance.

For example, projectors that have a HD greater than 1 m and emit light into an uncontrolled area where persons may be present should be positioned in accordance with "the fixed projector installation" parameters, resulting in a HD that does not extend into the audience area unless the beam is at least 2.0 meter above the floor level. In environments where unrestrained behavior is reasonably foreseeable, the minimum separation height should be greater than or equal to 3.0 meter to prevent potential exposure, for example by an individual sitting on another individual's shoulders, within the HD. Sufficiently large separation height may be achieved by mounting the image projector on the ceiling or through the use of physical barriers.

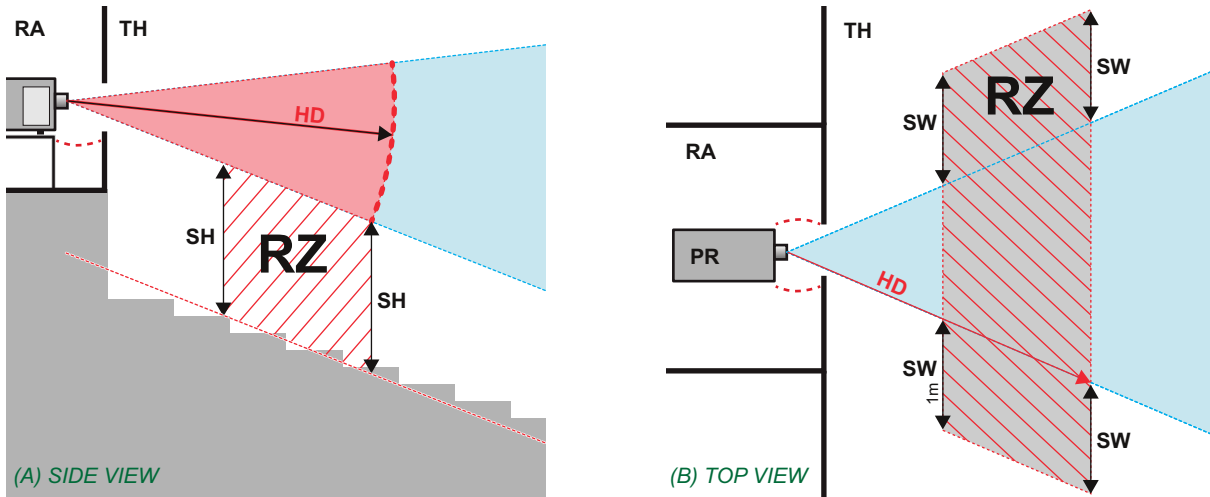

Image 1-2

- A** Side view.
- B** Top view.
- RA** Restricted Access location (boot area of projector).
- PR** Projector.

- TH** Theater.
- RZ** Restriction Zone in the theater.
- SH** Separation Height.
- SW** Separation Width.

Based on national requirements, no person is allowed to enter the projected beam within the zone between the projection lens and the related hazard distance (HD). This shall be physically impossible by creating sufficient separation height or by placing barriers. The minimum separation height takes into account the surface upon which persons other than operator, performers or employees are permitted to stand.

On Image 1-3 a typical setup is displayed. It must be verified if these minimum requirements are met. If required a restricted zone (RZ) in the theater must be established. This can be done by using physical barrier, like a red rope as illustrated in Image 1-3.

The restricted area sticker can be replaced by a sticker with only the symbol.

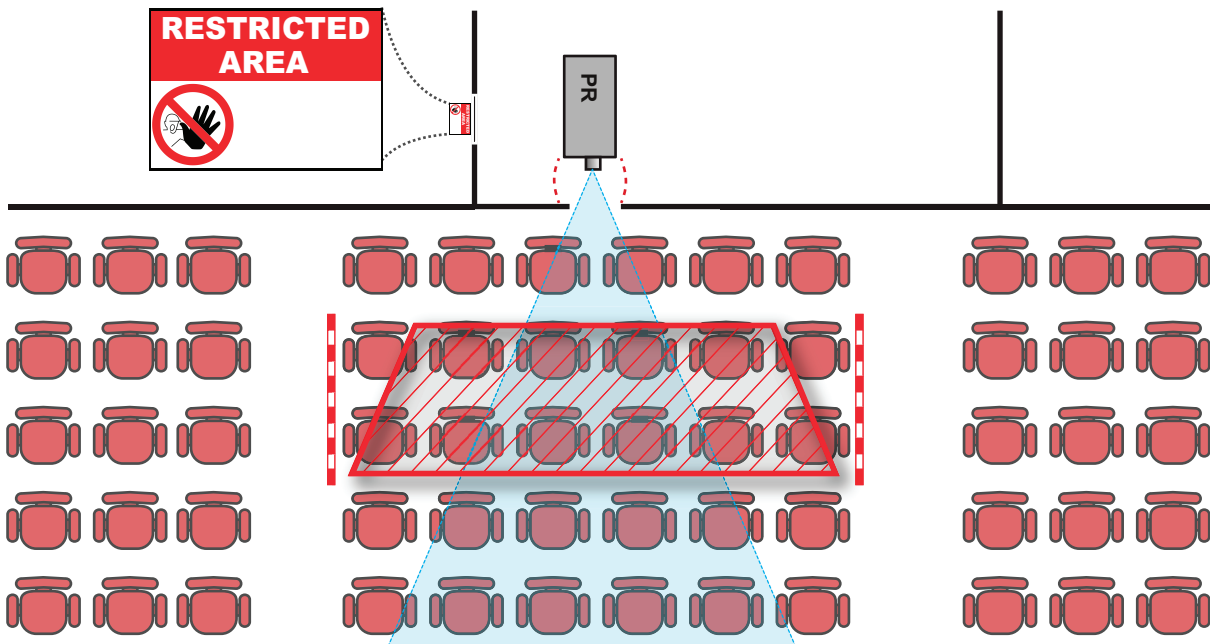

Image 1-3

USA market (For FDA notice No 57)

For LIPs (Laser Illuminated Projectors) installed in the USA market other restriction zone conditions apply.

LIPs for installation in restrained environment (cinema theaters) shall be installed at height vertically above the floor such that the bottom plane of the hazard distance zone shall be no lower than 2.5 meters above the floor. Horizontal clearance to the hazard distance zone shall be not less than 1 meter.

LIPs for installations in unrestrained environment (large venues,..) shall be installed at a height vertically above the floor such that the bottom plane of the Hazard distance Zone shall be no lower than 3 meters above the floor. Horizontal clearance to the hazard distance zone shall be not less than 2.5 meters. Any human access horizontally to the Hazard Zone, if applicable, shall be restricted by barriers. If human access is possible in an unsupervised environment, the horizontal or vertical clearances shall be increased to prevent exposure to the hazard distance zone.

In addition for temporary installations (e.g.: rental and staging, lease, events ...) the following requirements apply:

- This product can only be installed by Barco or sold or leased only to valid laser light show variance holders. In other words our installers are required to have an approved laser light show variance. Such installers may currently hold a valid variance for production of Class IIIb and IV laser light shows and/or for incorporation of the RG3 LIPs into their shows. Dealers and distributors are also required to obtain a valid laser light show variance.
- This product shall be located in such a way that all propagating beam paths within the Restriction Zone, and the audience can be directly observed at all times.
- Effects other than front or rear screen projections shall not be performed.
- Communication shall be maintained with other personnel assisting in surveillance of the LIP projection.
- In the event of any unsafe condition, immediately terminates (or designate the termination) of LIP projection light.

Install one or more readily accessible controls to immediately terminate LIP projection light. The power input at the projector side is considered as a reliable disconnect device. When required to switch off the projector, disconnect the power cord at the projector side. In case the power input at the projector side is not accessible (e.g. truss mount), the socket outlet supplying the projector shall be installed nearby the projector and be easily accessible, or a readily accessible general disconnect device shall be incorporated in the fixed wiring.

Laser light shows can be requested via the FDA online eSubmitter portal or via FDA Form FDA Form 3147 referencing to Barco's variance approval xxxx-xx-xxx.

The installation checklist for laser illuminated RG3 projectors must be fully completed after the installation and sent to pvg@barco.com. This checklist can be downloaded from the Barco website. Only when the installer is a valid laser light show variance holder the checklist should not be sent to Barco.

1.4.3 HD for fully enclosed projection systems

HD



Hazard Distance (HD) is the distance measured from the projection lens at which the intensity or the energy per surface unit becomes lower than the applicable exposure limit on the cornea or on the skin. The light beam is considered (to be) unsafe for exposure if the distance from a person to the light source is less than the HD.

Restriction Zone (RZ) based on the HD

The projector is also suitable for rear projection applications; projecting a beam onto a diffuse coated projection screen. As displayed in Image 1-4 two areas should be considered: the restricted enclosed projection area (RA) and the observation area (TH).

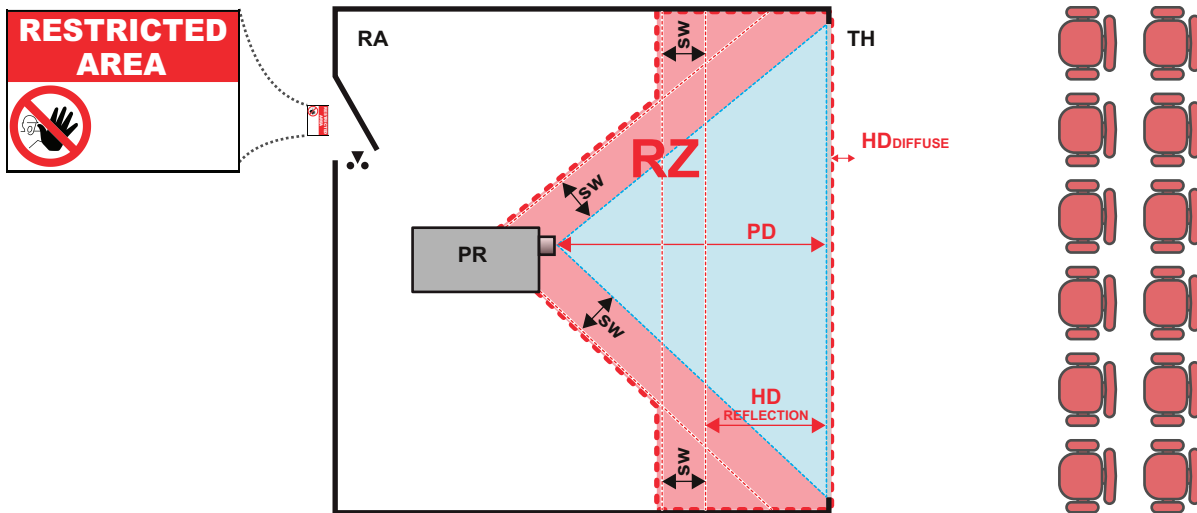

Image 1-4

- RA** Restricted Access location (enclosed projection area).
- PR** Projector.
- TH** Theater (observation area).
- RZ** Restriction Zone.
- PD** Projection Distance.
- SW** Separation Width. Must be minimum 1 meter.

For this type of setup 3 different HD shall be considered:

- HD as discussed in “High Brightness precautions: Hazard Distance (HD)”, page 15, relevant for intrabeam exposure.
- $HD_{\text{reflection}}$: the distance that has to be kept restrictive related to the reflected light from the rear projection screen.
- HD_{diffuse} : the relevant distance to be considered while observing the diffuse surface of the rear projection screen.

As described in “High Brightness precautions: Hazard Distance (HD)”, page 15, it is mandatory to create a restricted zone within the beam areas closer than any HD. In the enclosed projection area the combination of two restricted zones are relevant: The restricted zone of the projected beam toward the screen; taking into account 1 meter Separation Width (SW) from the beam onward. Combined with the restricted zone related to the rear reflection from the screen ($HD_{\text{reflection}}$); also taking into account a 1 meter lateral separation.

The $HD_{\text{reflection}}$ distance equals 25% of the difference between the determined HD distance and the projection distance to the rear projection screen. To determine the HD distance for the used lens and projector model see chapter “General considerations”, page 8.

$$HD_{\text{reflection}} = 25\% (HD - PD)$$

The light emitted from the screen within the observation shall never exceed the RG2 exposure limit, determined at 10 cm. The HD_{diffuse} can be neglected if the measured light at the screen surface is below 5000 cd/m² or 15000 LUX.

Product overview

2

Overview

- Main unit
- Input/Output (I/O) Panel
- Control panel
- Remote Control Unit (RCU)

2.1 Main unit

Component location

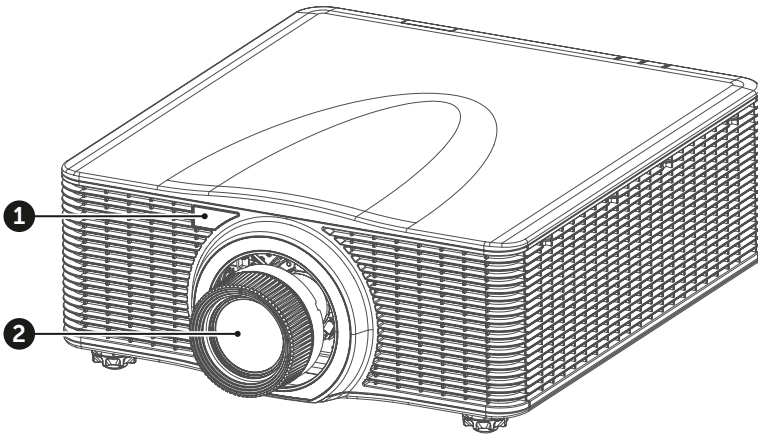

Image 2-1

- 1 Remote receiver (Front)
- 2 Projection lens

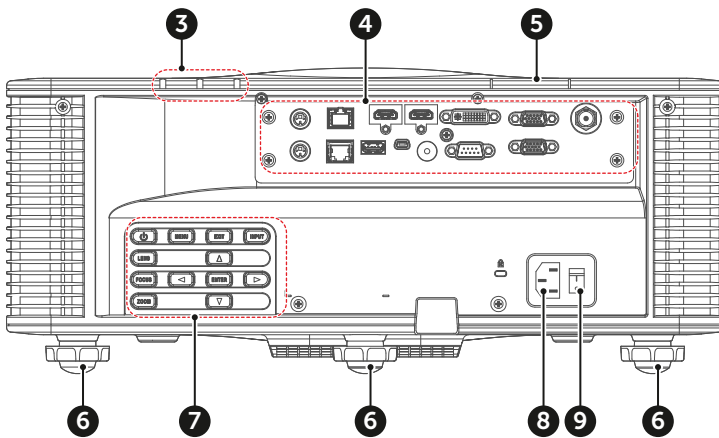

Image 2-2

- | | |
|----------------------------|--------------------------------------|
| 3 LED Status Indicator | 7 Control panel |
| 4 Input/Output (I/O) Panel | 8 Power socket (AC100-240V, 50-60Hz) |
| 5 Remote receiver (Top) | 9 Power switch |
| 6 Adjustable feet | |

Airflow

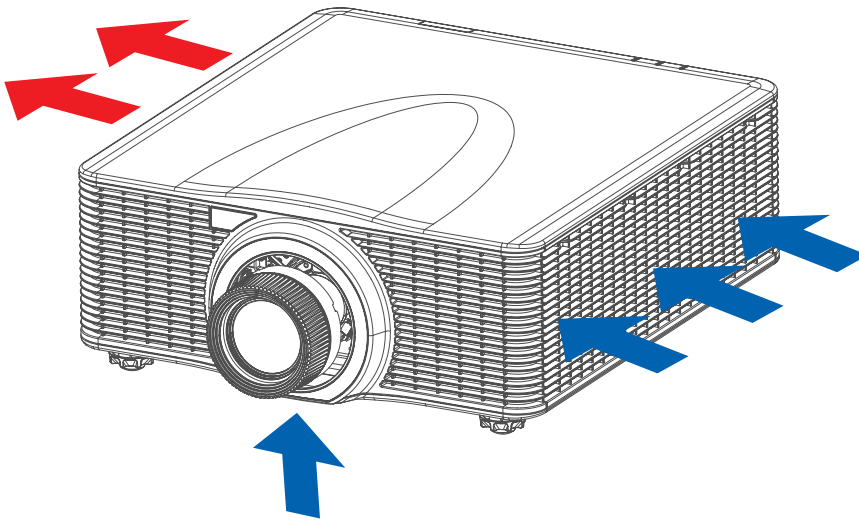

Image 2-3

2.2 Input/Output (I/O) Panel

Input and output ports location

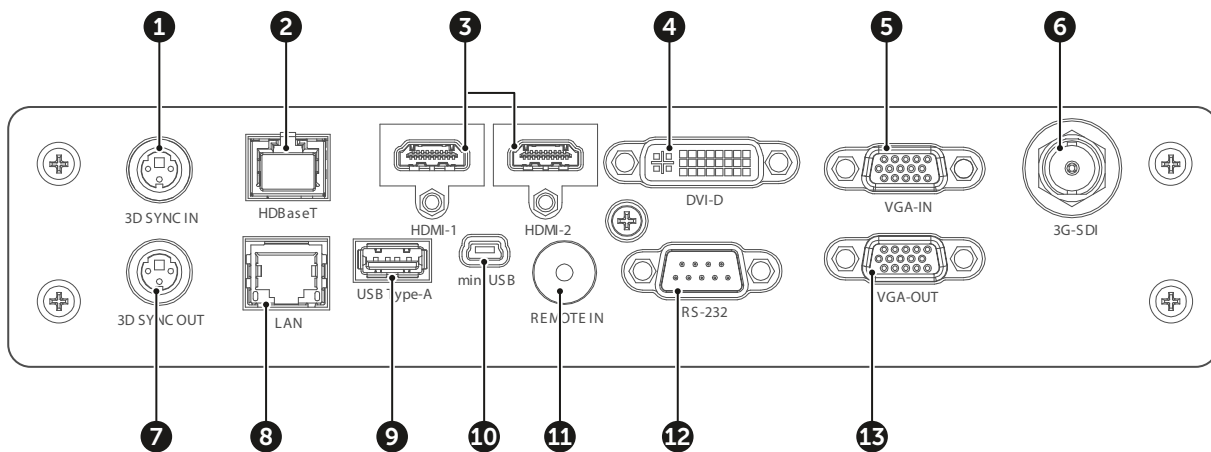

Image 2-4

- | | |
|--|--|
| <ul style="list-style-type: none"> 1 3D SYNC IN 2 HDBaseT connector 3 HDMI connector 4 DVI-D input connector 5 VGA-IN connector 6 3D-SDI connector 7 3D SYNC OUT | <ul style="list-style-type: none"> 8 Networking connector RJ45 9 USB Type-A (Power out 5V, 0.5A) 10 Mini USB (Service) 11 Wired remote connector 12 RS232 connector 13 VGA-OUT connector |
|--|--|

2.3 Control panel

Button location

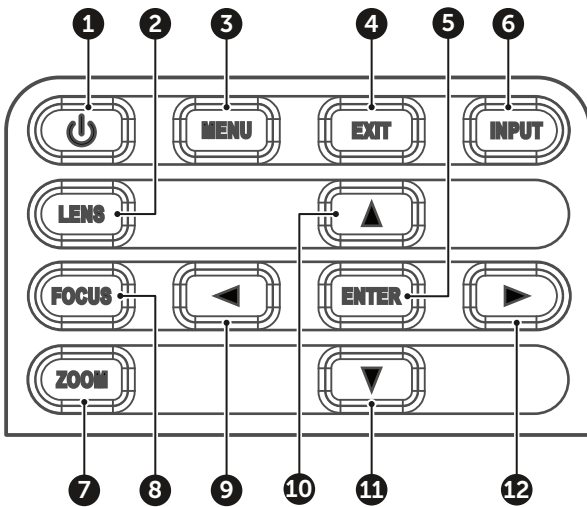

Image 2-5

- | | |
|----------------|-----------------|
| 1 POWER | 7 ZOOM |
| 2 LENS | 8 FOCUS |
| 3 MENU | 9 LEFT |
| 4 EXIT | 10 UP |
| 5 ENTER | 11 DOWN |
| 6 INPUT | 12 RIGHT |

Button function

Button	Function
POWER	Turn the projector on or off.
LENS	Adjust lens position.
MENU	Show the main menu on screen.
EXIT	Return to previous menu or exit menu if at top level.
ENTER	Confirm the settings.
INPUT	Select an input source.
ZOOM	Adjust the image size.
FOCUS	Adjust the image focus.
LEFT	Navigate left through the menu.
UP	Navigate up through the menu.
DOWN	Navigate down through the menu.
RIGHT	Navigate right through the menu.

2.4 Remote Control Unit (RCU)

Button identification

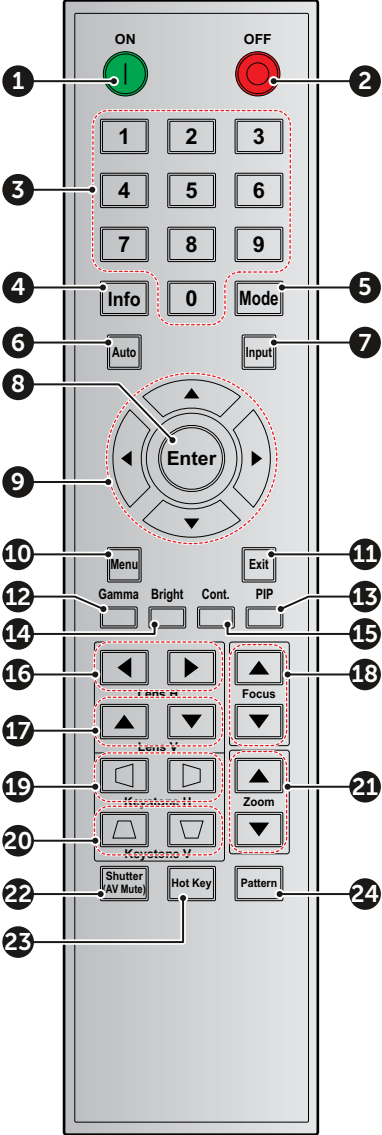
Button location	No.	Button	Function
	1	ON	Turn on the projector.
	2	OFF	Turn off the projector.
	3	Number	Input numbers (0-9).
	4	Info	Displays information on the source image.
	5	Mode	Select a preset picture mode.
	6	Auto	Automatically synchronize the projector to an input source.
	7	Input	Select an input source manually.
	8	Enter	Confirm an selection.
	9	Arrow keys	Use arrow keys to navigate through the menu or select the appropriate settings.
	10	Menu	Show the main menu on the screen.
	11	Exit	Back to previous Menu.
	12	Gamma	Set the gamma of the image.
	13	PIP	Set up the picture in picture (PIP) mode.
	14	Brightness	Set the brightness of the image.
	15	Contrast	Set the contrast of the image.
	16	Lens H	Adjust the image position horizontally.
	17	Lens V	Adjust the image position vertically.
	18	Focus	Adjust the image focus.
	19	Keystone H	Adjust a horizontally keystone image.
	20	Keystone V	Adjust a vertically keystone image.
	21	Zoom	Adjust the image size.
	22	Shutter	Momentarily turn off/on the screen (AV Mute).
	23	Hot Key	Select a specific function set as the hot key.
	24	Pattern	Display test patterns.

Powering On/Off the projector

3



This chapter assumes that the power cord and (all) signal cables are securely connected. For detailed instructions see installation manual.

Overview

- Powering On the projector
- Powering Off the Projector

3.1 Powering On the projector

How to power On the projector

1. Power on the AC switch (1) and wait until the power button on the control panel is solid red.

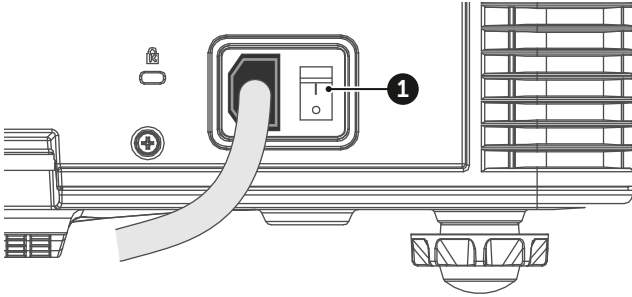

Image 3-1

2. Turn on the projector by pressing the POWER button (2) on the control panel or the ON key (3) on the remote control.



Image 3-2

The status LED (4) will flash orange. The startup screen will display and the status LED will turn to solid green.

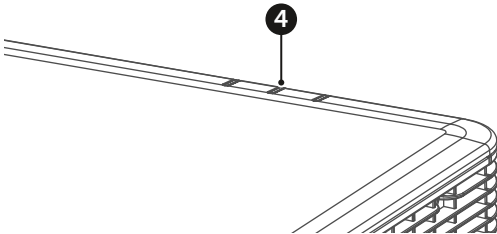

Image 3-3

3. Turn on your source. The projector detects the source you selected and displays the image.



Note: If you connect multiple sources at the same time, press “Input” key on the control panel or on the remote control to switch inputs.



WARNING: Do not look directly into the lens when the projector is turned on. The strong light might cause permanent eye damage.

3.2 Powering Off the Projector

How to power Off the projector

1. Press the POWER button (2) on the control panel or the OFF key (5) on the remote control, a message displays on the screen.

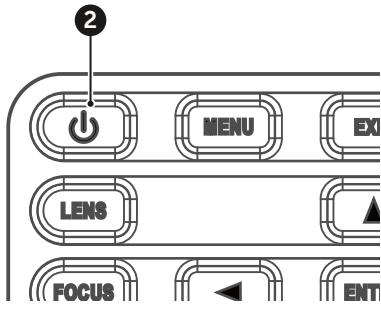
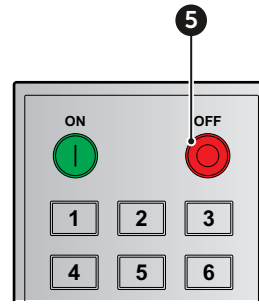

Image 3-4



2. Press the POWER button or OFF key again to confirm, otherwise the message disappears after 5 seconds and the projector remains on.



CAUTION: Don't turn on the projector immediately after entering Standby mode.

User controls

4

Overview

- On-Screen Display Menus
- Picture Menu
- Screen Menu
- Settings Menu
- Light Source Menu
- Options Menu
- 3D Menu
- Communications Menu
- Controlling the projector over network
- Using the web control center
- Using RS232 command by Telnet

4.1 On-Screen Display Menus

About OSD

The projector has On-Screen Display (OSD) menus that allow you to make image adjustments and change a variety of settings.

Follow the steps below to use the OSD menu to configure the projector settings.

How to operate

1. To open the OSD menu, press **Menu** key on the control panel or remote control.
2. Use arrow keys to navigate through the menus and select appropriate settings.
3. Press **Enter** to enter the submenu or confirm a setting.
4. Press **Exit** to return to the previous menu or exit OSD menu if at top level.

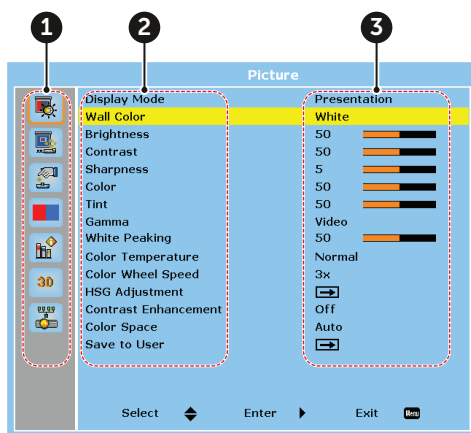

Image 4-1

- 1 Main menu
- 2 Sub-menus
- 3 Settings

4.2 Picture Menu

Overview

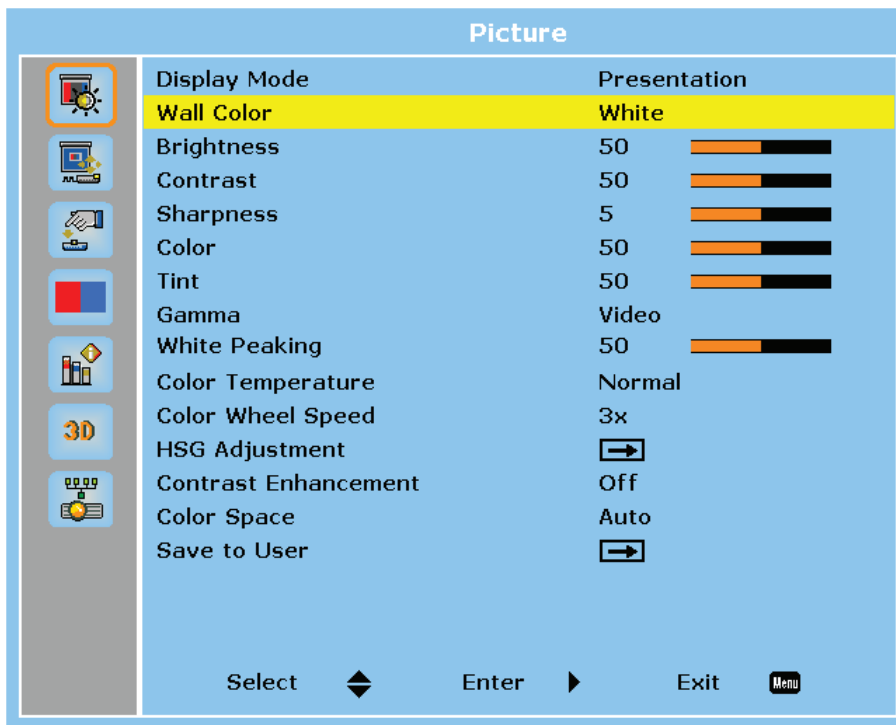

Image 4-2

Display Mode

Set the display mode to optimize the image performances for different display content.

- **Bright** : Best for high brightness applications.
- **Presentation** : Best for presentations when connected to a PC.
- **Movie** : Best for playing videos.
- **sRGB** : Best for high definition televisions.
- **Blending** : Best for multiple projector applications.
- **DICOM SIM** : Best for projecting monochrome medical images, such as X-ray diagram.
- **User** : The mode for the image settings saved by the user.

Wall Color

Set the wall color of the projector to achieve best color performance for a specific wall. The available options are White and Gray 130.

Brightness

Adjust the luminous brightness of the projected image.

Contrast

Adjust the contrast of the projected image.

Sharpness

Adjust the clarity of detail in the projected image.

Color

Transform a video image from black and white to fully saturated color.

Tint

Adjust the color balance of red and green in video images.

Gamma

Select appropriate gamma value to optimize the image conformance to different applications.

- **Video** : Best for video or TV sources.
- **Film** : Best for home theater applications.
- **Bright** : Best for emphasizing brightness.
- **CRT** : Best for CRT monitors.
- **DICOM** : Best for medical images, such as X-ray diagram.

White Peaking

Adjust the brightness of whites in the projected image, with 0 being the minimal level and 100 being the maximum.

Color Temperature

Adjust the color temperature of the projected image. The available options are Warm, Normal, and Cool.

Color Wheel Speed

The speed of the phosphor color wheel determines the image performance and the service life of the projector.

- **2x** : Extends the projector's service life and reduces the noise level during operation.
- **3x** : Increases the speed to eliminate the color artifacts for best image quality.

HSG Adjustment

HSG adjustment uses hue, saturation, and gain (HSG) to adjust the image's primary colors (red, green and blue) and secondary colors (cyan, magenta, and yellow). It helps calibrate the projected image to achieve better color conformance to the surroundings, in consideration of factors such as screen size, ambient lighting, and multiple projector applications.

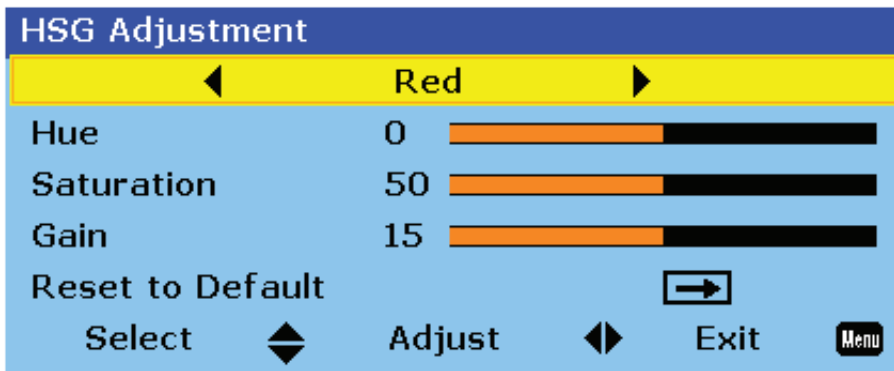

Image 4-3

- **Colors** : Select the color for further adjustment.
- **Hue** : Adjust the hue of the selected color. The value reflects the number of degrees of rotation around the chromaticity diagram from the original color. Increasing value indicates clockwise rotation, and decreasing value, counterclockwise rotation.

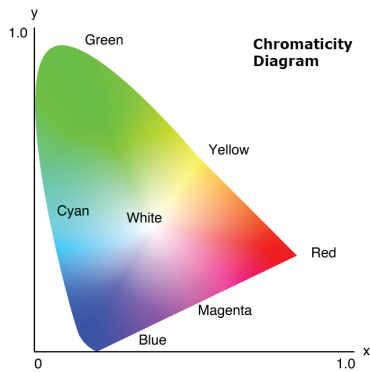

Image 4-4

- **Saturation** : Adjust the saturation of the selected color. The value indicates the color shifts from or towards the white in the center of the chromaticity diagram.
- **Gain** : Adjust the gain of the selected color. Increase the value to brighten the image (add white to a color) or decrease the value to darken the image (add black to a color).
- **Reset to Default** : Reset the color settings to factory default values.

Contrast Enhancement

Optimize the contrast ratio for different input sources.

- **Off** : Disable the contrast enhancement.
- **Dynamic Black** : Automatically adjust the contrast ratio for video sources.
- **Extreme Black** : Automatically increase the contrast ratio for blank (black) images.

Color Space

Select a color space that has been specifically tuned for the input signal. Use only for analog signals and certain digital sources. The available options are Auto, RGB (0-255), RGB (16-235), and YUV.

Save to User

Save the user settings.

4.3 Screen Menu

Overview

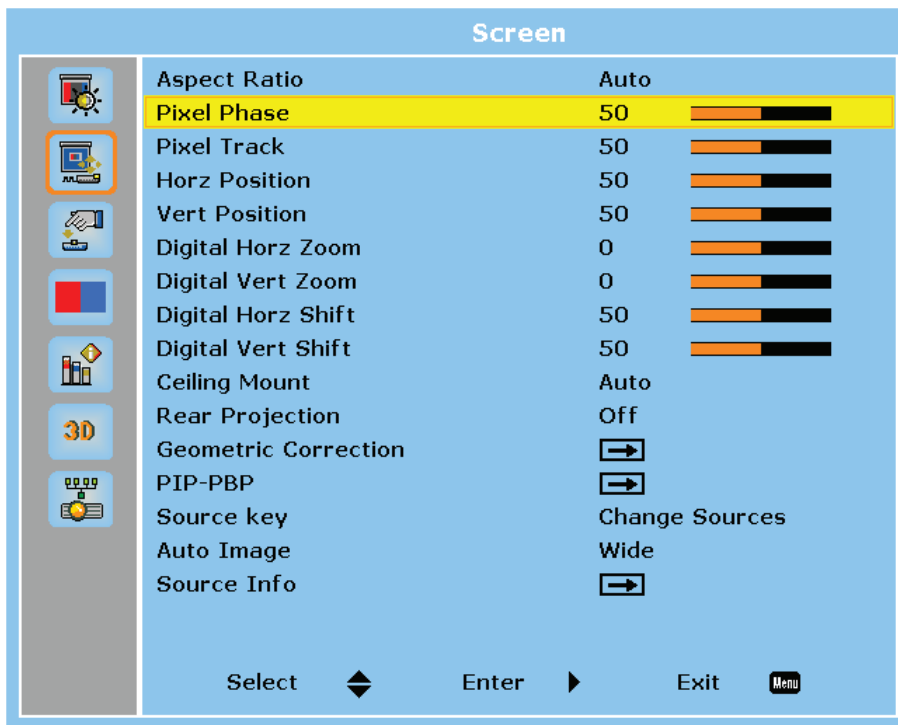

Image 4-5

Aspect Ratio

Set the aspect ratio of the projected image. The available options are Auto, 4:3, 16:9, 16:10. Select Auto to display the detected image size.

Pixel Phase

Adjust the phase of the pixel-sampling clock relative to the input signal. It helps to improve the quality of the image that shows shimmer or noise after being optimized with pixel tracking. This function applies to analog RGB signals only.

Pixel Track

Flickering or vertical stripes across the image indicates poor pixel tracking. Adjust the pixel track to optimize the image quality across the screen. This function applies to analog RGB signals only.

Horz Position

Adjust the horizontal position of the display area within the lens offset range.

Vert Position

Adjust the vertical position of the display area within the lens offset range.

Digital Horz Zoom

Change the horizontal size of the projected area. After re-sizing the image with this function, use Digital Horz Shift and Digital Vert Shift to move the image.

Digital Vert Zoom

Change the vertical size of the projected area. After re-sizing the image with this function, use Digital Horz Shift and Digital Vert Shift to move the image.

Digital Horz Shift

Adjust the horizontal position of the display area if it is resized through Digital Horz Zoom setting.

Digital Vert Shift

Adjust the vertical position of the display area if it is resized through Digital Vert Zoom setting.

Ceiling Mount

Flips the image upside down to project from a ceiling mount.

Rear Projection

Reverse the image to project behind a translucent screen.

Geometric Correction

Configure the geometric settings to reshape the image for different projection surface.

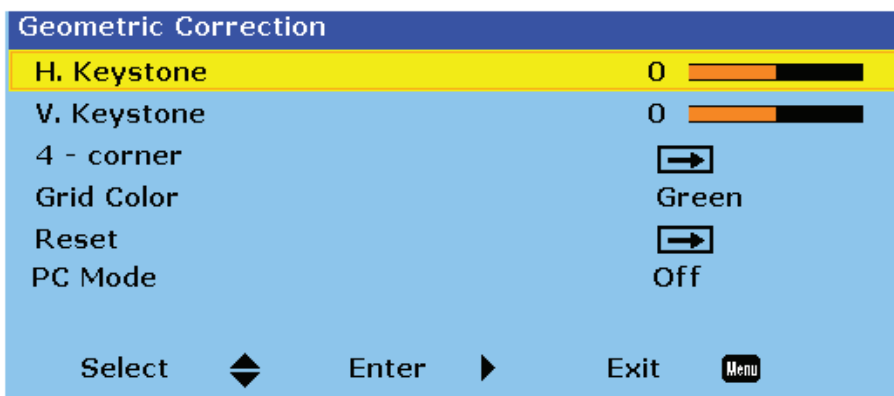

Image 4-6

- **H. Keystone** : Adjust the left and right side of the projected image to make it an even rectangle. It is used for the images with unequal left and right sides.

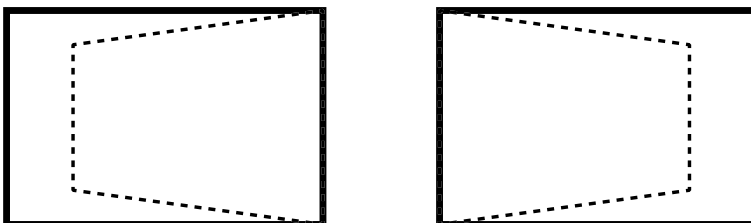

Image 4-7

- **V. Keystone** : Adjust the top and bottom side of the projected image to make it an even rectangle. It is used for the images with unequal top and bottom sides.

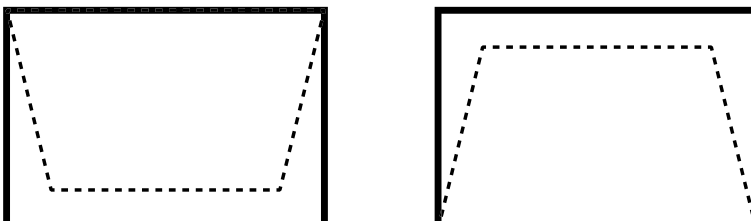

Image 4-8

- **4 - corner** : Position the 4 corners of the image to have it fit a specific projection surface.

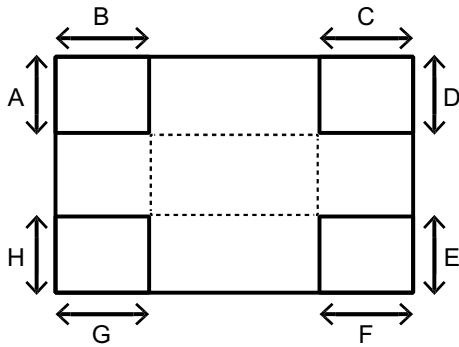

Image 4-9

- **Grid Color** : Set the grid color for 4-corner adjustment. The available options are purple or green.
- **Reset** : Reset geometric settings to factory default values.
- **PC Mode** : Enable PC mode to use PC software for more complicated geometric configuration.

PIP/PBP

PIP/PBP (picture in picture/picture by picture) mode allows displaying two images from two independent sources. For more information on the PIP/PBP compatibility, See “Compatibility modes”, page 57.

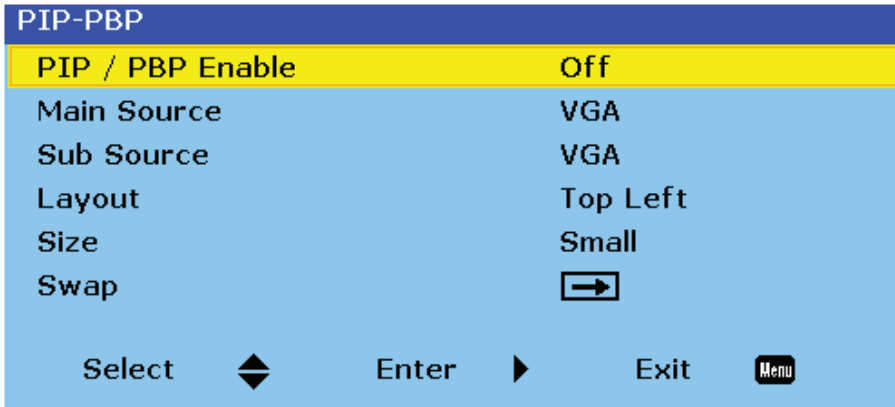





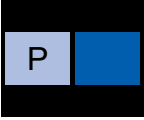



Image 4-10

- **PIP/PBP Enable** : Select the appropriate PIP/PBP mode.
 - **Off** : Disable PIP/PBP mode.
 - **PBP** : Display two input sources simultaneously on the left and right sides of the screen.
 - **PIP** : Display one input source on the main screen and the other input source in an inset window.
- **Main Source** : Select an input source for the main image.
- **Sub Source** : Select an input source for the second image.
- **Layout** : Adjust the layout of two images. In the layout chart below, the “P” indicates the main image:

PIP Layout	PIP Size		
	Small	Medium	Large
PIP, Bottom Right			
PIP, Bottom Left			

PIP Layout	PIP Size		
	Small	Medium	Large
PIP, Top Left			
PIP, Top Right			
PBP Layout			
PBP, Main Left		PBP, Main Right	
			

- **Size** : Change the display size of the sub source in PIP mode.
- **Swap** : Swap the main source and sub source.

Source Key

Configure the source settings.

- **Change Sources** : Change the input source.
- **List All Sources** : List all input sources.
- **Auto Source** : Automatically detect and select input source.

Auto Image

Select the timing detection mode to support input signal with marginal quality. After the selection, the projector will reacquire and lock the signal.

- **Normal** : Best for 4:3 input source.
- **Wide** : Best for 16:9 input source and most 4:3 input source.

Source Info

Display the information of the current input source.

4.4 Settings Menu

Overview

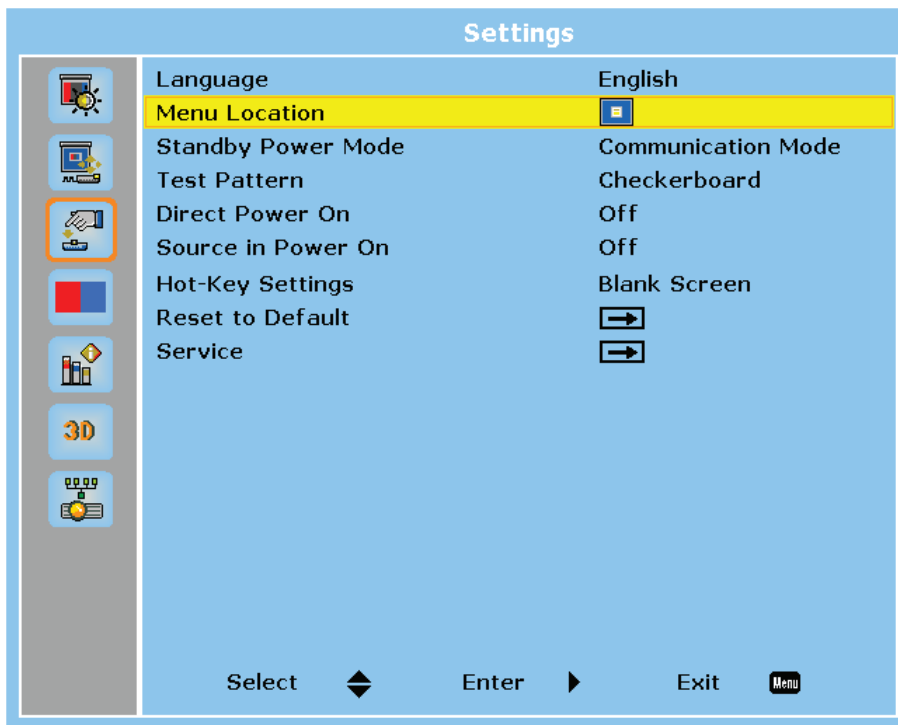

Image 4-11

Language

Select the language of the OSD menu. The available languages are English, Simplified Chinese, French, German, Italian, Japanese, Korean, Russian, Spanish, Portuguese, Indonesian, Dutch.

Menu Location

Adjust the location of the OSD menu. The available positions are Left Top, Right Top, Center, Left Bottom and Right Bottom.

Standby Power Mode

Select the power mode for the projector in standby status.

- **Standby Mode** : Minimum power consumption (0,5 Watt) which does not allow controlling the projector over the network.
- **Network Standby Mode** : Low power consumption (< 2W) which allows the LAN module to enter sleep mode and supports to be woken by Wake on LAN (WoL). When the LAN module is woken by WoL, the projector is ready to receive commands over the network.
- **Communication Mode** : More power consumption that allows controlling the projector over the network.

Test Pattern

Select a test pattern. The available options are None, Grid, White, Black, Checkerboard, and Color Bars.

Direct Power On

Turn on this function to have the projector automatically turning on when connected to AC power.

Source in Power On

Turn on this function to have the projector automatically turning on when connected to HDMI input sources. It only applies to the standby projector set to Communication Mode.

Hot-Key Settings

Assign a specific function to the “Hot Key” button on the remote control. It allows you to use the function easily without going through the OSD menus. The available functions for “Hot Key” button are Blank Screen, Aspect Ratio, Freeze Screen, and Projector Info.

Reset to Default

Reset all settings to the factory default values.

Service

The service menu is only available to Barco qualified service technicians.

4.5 Light Source Menu

Overview

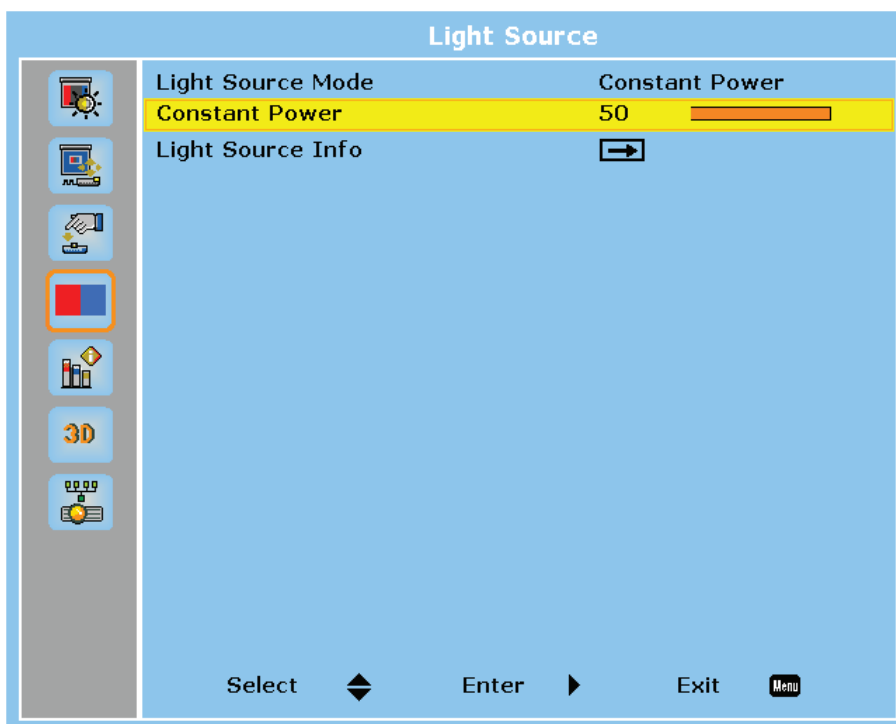

Image 4-12

Light Source Mode

Set up the light source mode depending on the installations.

- **Constant Power** : Enable the Constant Power to meet different installation requirements.
- **Constant Intensity** : Select to maintain the current constant brightness and color settings. It is used after the Constant Power is enabled.
- **ECO** : Set the projector to 50% constant brightness and color settings.

Constant Power

Select a value for the laser diode power. The value ranges from 0 to 99, which covers the power level from 30% to 100%. The power level can be managed to obtain the brightest image or longest service life.

Light Source Info

Display the total used hours of the laser diode and information on light sensor calibration

4.6 Options Menu

Overview

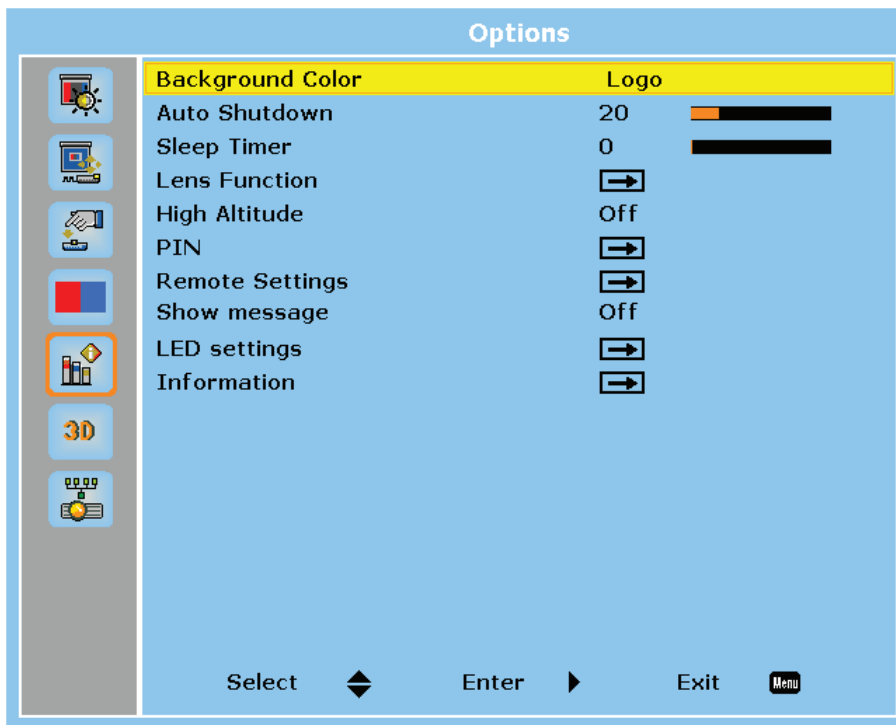

Image 4-13

Background Color

Select the background color when no signal is detected. The available options are Logo, Blue, Black, and White.

Auto Shutdown

Set a time value for the projector to automatically turn off if no signal is detected within the specified time period.

Sleep Timer

Set a time value for the projector to automatically turn off after operating for the specified amount of time.

Lens Function

Configure the lens settings.

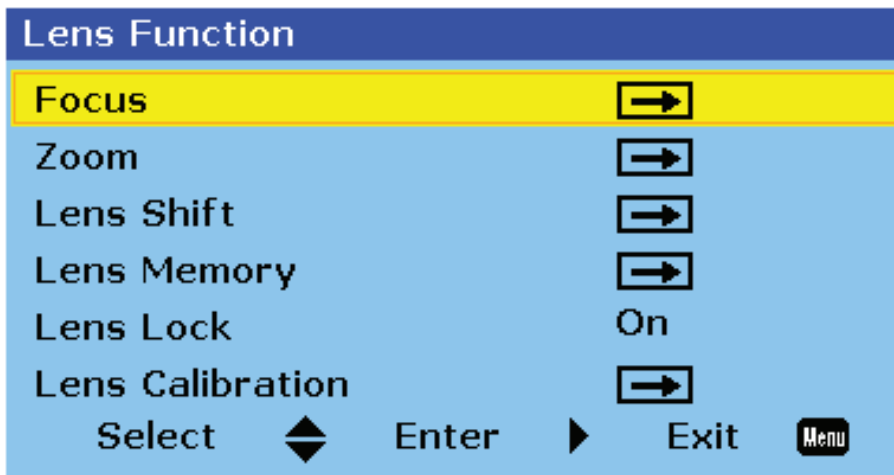

Image 4-14

- **Focus** : Use up and down arrow keys to adjust the focus of the projected image.
- **Zoom** : Use up or down arrow keys to zoom in or zoom out the projected image.
- **Lens Shift** : Use arrow keys to adjust the lens position to shift the projected area.
- **Lens Memory** : Save or apply the current lens position. The projector can save up to five records.
- **Lens Lock** : Lock the lens to prevent the lens motors from moving.
- **Lens Calibration** : Calibrate the lens to return it to the center position.

High Altitude

When the projector is operated at the altitude over 5,000ft (1,500m), enable this function to have the projector fans operating at high speed to ensure proper air circulation.

PIN

Set a PIN number to protect the projector.

- **PIN Protect** : Enable PIN Protect to protect the project. A PIN number is required once this function is enabled. (Default: 12345)
- **Change PIN** : Change the PIN number.

Remote Settings

Set up the remote receiver to control the communication between the projector and the remote control.

- **Top** : Enable or disable the top remote receiver.
- **Front** : Enable or disable the front remote receiver.
- **HDBaseT** : Select On to set the HDBaseT terminal as the remote receiver.
- **Projector Address** : Set a specific number for the projector as its address. The projector will only responds to the remote control set with the same address.

Show Messages

Turning on or off the on screen messages showing the projector status information, such as input source, IP address, and gamma.

LED Settings

Configure the status LED indicators to help identify the projector status. The definitions of the status LED are discussed in the chapter “LED indication chart”, page 50.

- **Keypad LED** : Turn on or off the keypad backlight.
- **Status LED** : Turn on or off the status LED indicators, or select Warning/Errors Only to enable the indicators for warning and error only.

Information

Display the projector information, such as model name, firmware version, and main input.

4.7 3D Menu

Overview

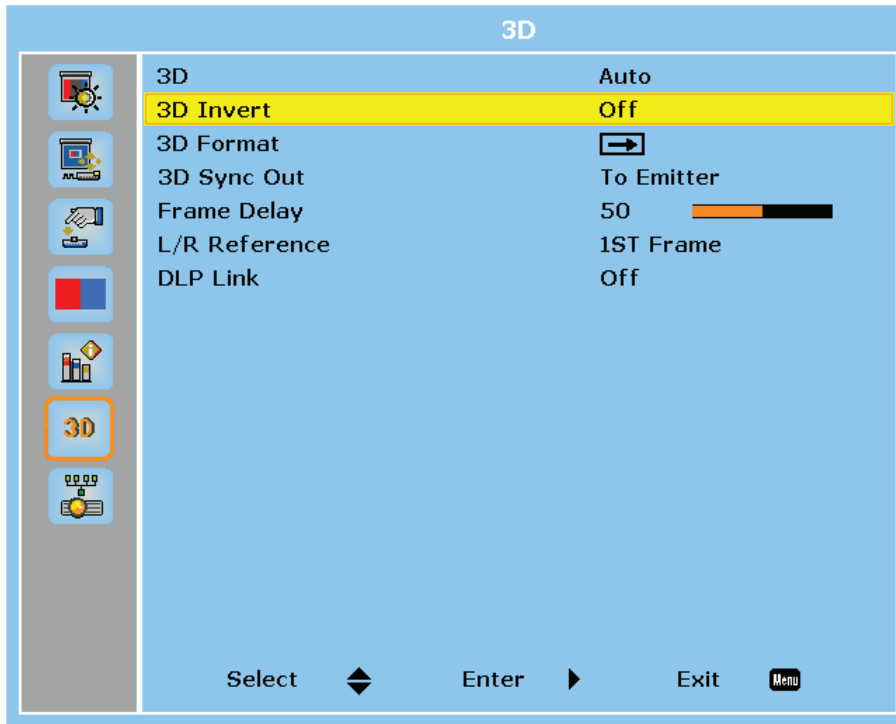

Image 4-15

3D

Enable the 3D function.

- **Auto** : The projector automatically enables 3D function when receiving the 3D input in 1.4a format.
- **On** : Turn on the 3D function manually.

3D Invert

3D video files and images combine two slightly different images (frames) of the same scene representing the different views that the left and right eyes see. When these frames are displayed fast enough and viewed with 3D glasses synchronized with the left and right frames, the viewer's brain then assembles the separate images into a single 3D image. When the 3D image does not appear correctly, invert the sequence of the left and right frames.

3D Format

Select a proper 3D format for the 3D input signal. The available options are Frame Packing, Side-by-Side (Half), Top and Bottom, and Frame Sequential.

3D Sync Out

Set up the transmission of the 3D sync output signal.

- **To Emitter** : Send the 3D sync output signal to the emitter connected to the projector's 3D sync out port.
- **To Next Projector** : For multiple projector applications, send the 3D sync output signal to next projector.

Frame Delay

Set a frame delay value for the projector to correct the time difference between the 3D signal being given and the result being executed. This function works only when L/R Reference is set to Field GPIO.

When performing 3D blending on multiple projectors, set the frame delay for each projector to correct the none synchronous images.

L/R Reference

Select the reference for left and right (L/R) frames.

- **1ST Frame** : When the projector generates 3D sync signal internally, select this option to set the first frame of the input source as the projector's left reference. If the 3D image does not appear correctly, use 3D Invert function to swap the left and right frames.
- **Field GPIO** : When the projector receives external 3D sync signal through a 3D sync in cable, select this option to have the projector's L/R reference synchronizing with the 3D sync signal from the 3D sync in cable.

DLP Link

Enable or disable the DLP Link function according to how the 3D sync signal is processed.

- **On** : Turn on DLP Link when the 3D sync signal is generated by the DLP Link technology built-in the projector. DLP Link works only with the glasses that are compatible with DLP 3D technology and the 3D function is enabled.
- **Off** : Turn off DLP Link when the 3D sync out signal is sent to an emitter or another projector through the 3D sync out port.

4.8 Communications Menu

Overview

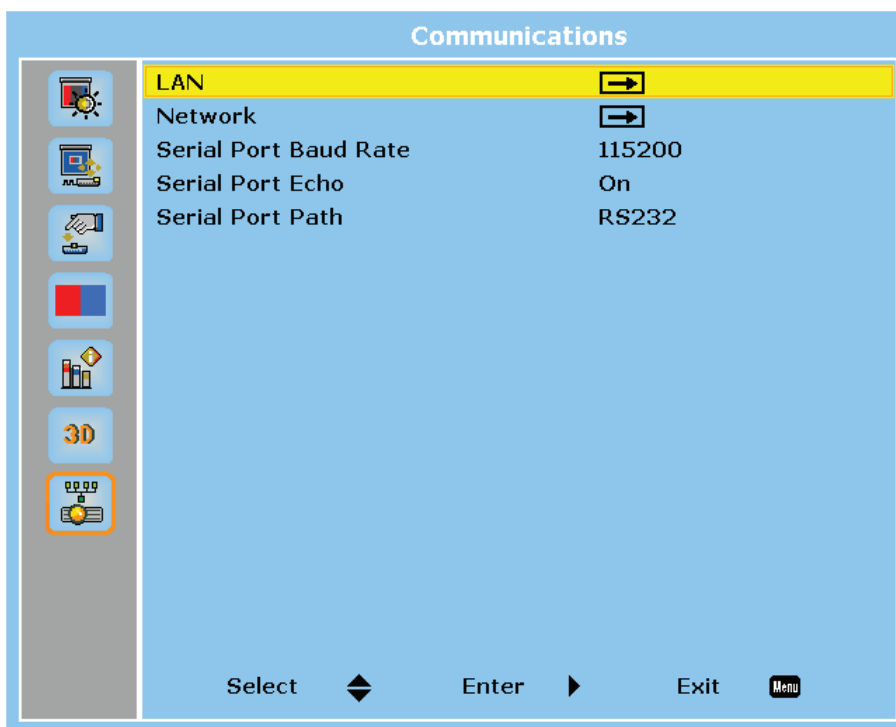

Image 4-16

LAN

Configure the LAN settings for network communications.

- **DHCP** : Turn on DHCP to automatically acquire IP address, subnet mask, gateway, and DNS. If it is turned off, manually enter the values for the network.
- **IP Address** : Set the projector's IP address.
- **Subnet Mask** : Set the projector's subnet mask.
- **Default Gateway** : Set the projector's gateway.
- **MAC Address** : Display the MAC address.
- **Apply** : Apply the network settings.

Network

View and configure the projector's network settings.

- **Projector Name** : Display the projector name.
- **Show Network Messages** : Select On to display network information as on screen messages.
- **Network Factory Reset** : Reset the network settings to factory default settings.

Serial Port Baud Rate

Select a serial port and baud rate. The available options include 1200, 2400, 4800, 9600, 14400, 19200, 38400, 57600, and 115200.

Serial Port Echo

When set to On, the projector will return the serial command it receives. The user can view the command that has been sent to the projector.

Serial Port Path

Select the serial port path for the serial commands. The available options are RS232 or HDBaseT.

4.9 Controlling the projector over network

About controlling

This projector can be controlled remotely by a computer or other external devices through network connection. It allows the user to control one or more projectors from a distant control center, such as powering the projector on or off, and adjusting the image brightness or contrast. This projector is compatible with following control devices and commands.

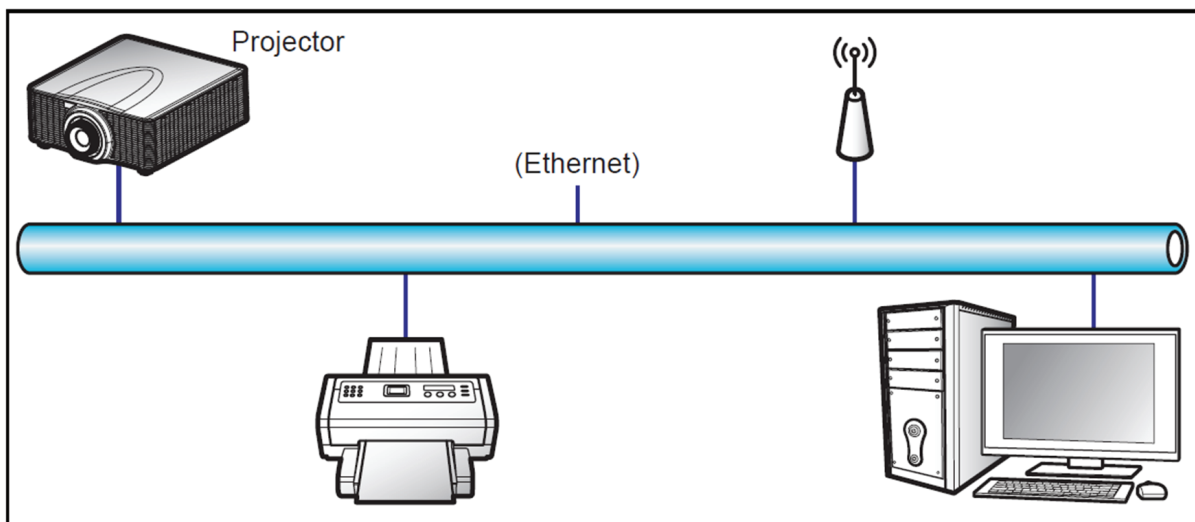

Image 4-17

- **Crestron**: The projector can be controlled with Crestron controller and related software, for example Room-View®. (Port: 41794)
For more information, please visit <http://www.crestron.com>.
- **Extron**: The projector can be controlled with Extron devices. (Port: 3023)
For more information, please visit <http://www.extron.com>.
- **PJ Link**: The projector can be controlled with PJLink v1.0 commands. (Port: 4352)
For more information, please visit <http://pjlink.jbmia.or.jp/english>.
- **AMX Device Discovery**: The projector can be controlled with AMX devices. (Port: 9131)
For more information, please visit <http://www.amx.com>.
- **Telnet**: Support using RS232 commands via Telnet connection. (Port: 23)
For more information, see "Using RS232 command by Telnet", page 47.
- **HTTP**: The projector can be controlled with a web page control center. (Port: 80)

For more information, see “Using the web control center”, page 45.



For more information about the various types of external devices which can be connected to the LAN / RJ45 port and remotely control the projector, as well as the supported commands for these external devices, please contact the Support-Service directly.

4.10 Using the web control center

About web control center

Web control panel allows the user to configure various projector settings using a web browser from any personal computer or mobile devices.

System requirement

To use the web control panel, make sure your devices and software meet the minimum system requirements.

- RJ45 cable (CAT-5e) or wireless dongle
- PC, laptop, mobile phone, or tablet installed with a web browser
- Compatible web browsers:
 - Internet Explorer 11 or higher version
 - Microsoft Edge 40 or higher version
 - Firefox 57 or higher version
 - Chrome 63 or higher version
 - Safari 11 or higher version
- Operating system of the mobile devices:
 - iOS 10 or higher version
 - Android 5 or higher version

Overview of the web control center

Configure the projector settings using web browser.

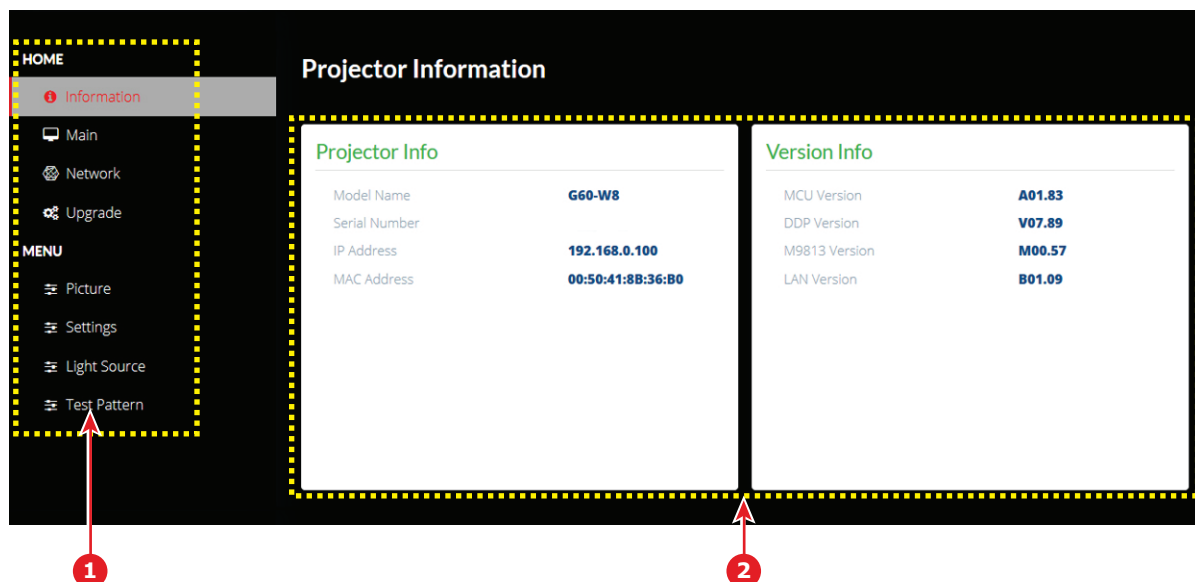

Image 4-18

- 1 Menu
- 2 Settings

Menu	Submenu	Description
HOME	Information	View the projector information and firmware version details.

Menu	Submenu	Description
	Main	<ul style="list-style-type: none"> Select the projector input sources. Enable or disable the projector power, shutter, and messages.
	Network	<ul style="list-style-type: none"> Configure the LAN settings. Set up the Crestron Control System (CCS) connection.
	Upgrade	Upgrade the projector firmware.
MENU	Picture	Adjust the basic image settings, such as brightness and contrast.
	Settings	Enable ceiling mount projection and set up the standby mode.
	Light Source	Select a light source mode and set the power level for constant power.
	Test Pattern	Select a test pattern.

Accessing the web control panel

When network is available, connect the projector and the computer to the same network. Use the projector address as the web URL to open the web control panel in a browser.

- Check the projector address using the OSD menu.
 - In a wired network, select *Network > LAN > IP Address*. Make sure DHCP is enabled.
 - In a wireless network, select *Network > WLAN > Gateway*.
- Open a web browser and type the projector address in the address bar. The web page redirects to the web control panel.



When network is not available, see *Directly connect the projector to a computer*.

Directly connect the projector to a computer

When network is not available, connect the projector to the computer directly using a RJ-45 cable, and configure the network settings manually.

- Assign IP address to the projector
 - From the OSD menu, select *Network > LAN*.
 - Turn off DHCP, and manually set the projector's IP Address, Subnet Mask, and Gateway.
 - Press **Enter** to confirm the settings.

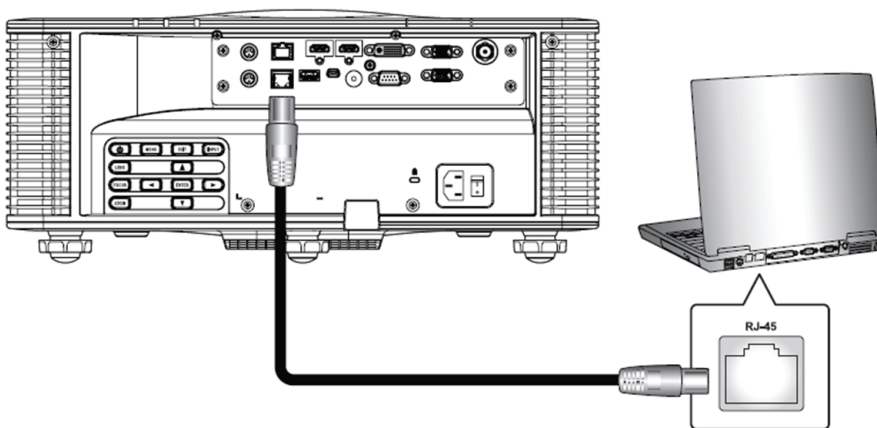

Image 4-19

- Assign IP address to the computer
 - Set the Default Gateway and Subnet Mask of the computer to match the projector.

- Set the IP address of the computer to match the first three numbers of the projector. For example, if the projector IP address is 192.168.000.100, set the computer IP address to 192.168.000.xxx, where xxx is not 100.
3. Open a web browser and type the projector address in the address bar.
The web page redirects to the web control panel.

4.11 Using RS232 command by Telnet

How to use

This projector supports using RS232 commands through Telnet connection.

1. Set up direct connection between the projector and computer. See block Directly connect the projector to a computer, in “Controlling the projector over network”, page 44
2. Disable the firewall on the computer.
3. Open the command dialogue on the computer. For Windows 7 operating system, select *Start > All Programs > Accessories > Command Prompt*.
4. Input the command “telnet ttt.xxx.yyy.zzz 23”.
Replace “ttt.xxx.yyy.zzz” with the projector IP address.
5. Press **Enter** on the computer keyboard.

Specification for RS232 by Telnet

- Telnet: TCP
- Telnet port: 23 (contact service team for more details)
- Telnet utility: Windows “TELNET.exe” (console mode).
- Disconnection for RS232-by-Telnet control normally: Close
- Below are the limitations for using Windows Telnet utility directly after TELNET connection is ready:
 - There is less than 50 bytes for successive network payload for Telnet-Control application.
 - There is less than 26 bytes for one complete RS232 command for Telnet-Control.
 - Minimum delay for next RS232 command must be more than 200 (ms).

5

Troubleshooting



If you experience a problem with your projector, please refer to the following information. If a problem persists, please contact your local re-seller or service center.

Overview

- LED indication chart
- Projector Problems

5.1 LED indication chart

Overview

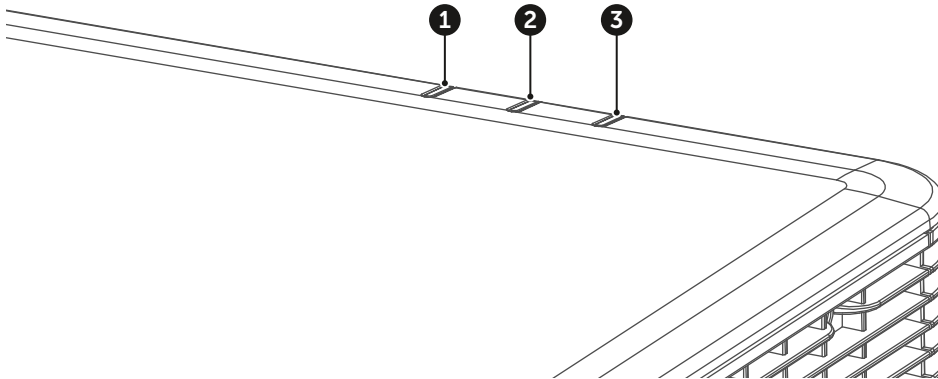

Image 5-1

- 1 Light LED
- 2 Status LED
- 3 AV Mute LED

Explanation

Message	Light LED			Status LED			AV Mute LED	
	Green	Orange	Red	Green	Orange	Red	Green	Orange
Standby State								
Power on (Warm up)					Flash- ing			
Power on & Laser diode on	Steady			Steady			Steady	
AV mute is off (Image is displayed)	Steady			Steady			Steady	
AV mute is on (Image is black)	Steady			Steady				Steady
Projector communication	Steady			Flash- ing			Steady	
Firmware upgrade				Flash- ing	Flash- ing			
Laser diode time has expired		Steady						
Unit loses over 60% initial luminance								
Error (Over temperature)						Steady		
Error (Fan failure)						Flash- ing		



Power key of the keypad is in steady red light when the projector enters standby mode.

5.2 Projector Problems

No image appears on-screen

- Check if all the cables and the AC power are correctly connected. For more details, refer to the installation manual.
- Check if the pins of the connectors are not crooked or broken.
- Check if the “Shutter (AV Mute)” function is disabled.

Partial, scrolling or incorrectly displayed image

- Press “Auto” on the remote control to detect input signal automatically.
- If you are using a PC, set the PC’s resolution lower or equal to WUXGA (1920 × 1200).
- If you are using a Notebook:
 - Set the resolution lower or equal to WUXGA (1920 × 1200).
 - Press the appropriate keys listed below for your notebook manufacturer to send signal out from notebook to projector. Example: [Fn]+[F4]

Acer	[Fn]+[F5]
Asus	[Fn]+[F8]
Dell	[Fn]+[F8]
Gateway	[Fn]+[F4]
BM/Lenovo	[Fn]+[F7]
HP/Compaq	[Fn]+[F4]
NEC	[Fn]+[F3]
Toshiba	Fn]+[F5]
Mac Apple	System Preference > Display > Arrangement > Mirror display

- If you experience difficulty changing resolutions or your monitor freezes, restart all equipments including the projector.

Image is flickering and shimmering

- Adjust the pixel phase and pixel track of the projector. See “Pixel Phase” and “Pixel Track” in chapter “Screen Menu”, page 34.

Image is fuzzy and blurry

- Press the “Focus ▲” or “Focus ▼” button on the remote control or control panel to adjust the image focus until it is sharp and clear. To adjust focus from OSD menu, select “Options > Lens function > Focus”.
- Make sure the projection screen is in proper distance with the projector. For projection distances of each lens, see chapter installation manual.

Stretched when displaying 16:10 DVD videos

- Set appropriate aspect ratio for the projector by selecting “Screen > Aspect Ratio” from the OSD menu.
- Set the aspect ratio to 16:10 on the DVD player.

Image is too small or too large

- Adjust the image size by pressing the “Zoom ▲” or “Zoom ▼” button on the remote control or control panel, or selecting “Options > Lens function > Zoom” from the OSD menu.
- Adjust the distance between the projector and the screen.
- Adjust the aspect ratio by selecting “Screen > Aspect Ratio” from the OSD menu.

Image is not an even rectangle

- Perform keystone correction by pressing the “Keystone H” and “Keystone V” button on the remote control, or using “Screen > Geometric Correction > V. Keystone or “H. Keystone” from the OSD menu.

Image is reversed

- To reverse the image, enable rear projection by selecting “Screen > Rear Projection > On” from the OSD menu.

The projector stops responding to all controls

- If possible, turn off the projector, then unplug the power cord and wait at least 60 seconds before reconnecting power.

If the remote control does not work

- Check if the operating angle of the remote control is pointed within $\pm 30^\circ$ (front and back) to the remote receivers on the projector. Make sure there are any obstructions between the remote control and the projector.
- Check the remote batteries. Make sure batteries are inserted correctly. Replace the batteries if they are used up.
- Ensure you have set the correct IR code to the remote control. See “Remote Settings” in the chapter “Options Menu”, page 40.

Specifications



Overview

- Product specification of the G60-W7
- Product specification of the G60-W8
- Product specification of the G60-W10
- Compatibility modes
- Dimensions of the G60
- Ceiling mount

A.1 Product specification of the G60-W7

Specifications

Projector type	Single chip DLP laser phosphor projector
Resolution	1,920 x 1,200 (WUXGA)
Brightness	6,300 ANSI lumens 6,600 center lumens 7,000 ISO lumens
Contrast ratio	1,200:1 sequential; 6,000:1 dynamic; Extreme black: 100,000:1
Brightness uniformity	85%
Aspect ratio	16:10
Lens type	G-lenses - 0.36:1 / 0.75-0.95:1 / 0.95-1.22:1 / 1.22-1.52:1 / 1.52-2.92:1 / 2.90-5.50:1
Optical lens shift	Vertical up to 100%, depending on lens Horizontal up to 30%, depending on lens Motorized zoom and focus Motorized lens shift
Color correction	Yes
CLO (constant light output)	Yes
Light source	Laser phosphor
Light source lifetime	Up to 20,000hrs
Sealed DLP™ core	Yes
Orientation	360° rotation, no restrictions
3D	Active stereoscopic 3D
Image processing	Embedded warp & blend possible via Ptoolset
Keystone correction	Yes
Inputs	2x HDMI 1.4 / DVI-D / HDBaseT / 3G-SDI / VGA (D-Sub 15 pin) / RJ 45 Ethernet / RS232 in
Input resolutions	Up to 1,920 x 1,200 @ 60Hz refresh rates: 24Hz to 120Hz for 720p (1280x720) and 24Hz to 60Hz for WUXGA (1920x1200)
Software tools	Projector Toolset
Control	IR, RS232, RJ45, 3.5mm phone jack for wired remote
Network connection	10/100 Ethernet, RJ45
Power requirements	100-240V / 50-60Hz
Power consumption	520W nominal, 600W maximum
BTU per hour	1,780 BTU/h nominal; 2,050 BTU/h maximum
Standby power	less than 0.5W
Noise level (typical at 25°C/ 77°F)	36dB(A) - 40dB(A) depending on the used mode
Operating temperature	5 - 40 °C (sea level)

Storage temperature	-10 to 60 °C
Operating humidity	10 - 85% RH, non-condensing
Storage humidity	5 - 90% RH, non-condensing
Dimensions (WxLxH)	without feet: 484 x 529 x 195 mm / 19.06 x 20.83 x 7.68 in
Weight	without lens: 16.9 kg / 37.3 lbs
Standard accessories	Power cord, wireless remote control
Certifications	CE, FCC Class A, cTUVUS, CCC, EAC, KCC, RCM, BIS, BSMI
Warranty	Limited 3 years parts and labor

A.2 Product specification of the G60-W8

Specifications

Projector type	Single chip DLP laser phosphor projector
Resolution	1,920 x 1,200 (WUXGA)
Brightness	7,300 ANSI lumens 7,700 center lumens 8,200 ISO lumens
Contrast ratio	1,200:1 sequential; 6,000:1 dynamic; Extreme black: 100,000:1
Brightness uniformity	85%
Aspect ratio	16:10
Lens type	G-lenses - 0.36:1 / 0.75-0.95:1 / 0.95-1.22:1 / 1.22-1.52:1 / 1.52-2.92:1 / 2.90-5.50:1
Optical lens shift	Vertical up to 100%, depending on lens Horizontal up to 30%, depending on lens Motorized zoom and focus Motorized lens shift
Color correction	Yes
CLO (constant light output)	Yes
Light source	Laser phosphor
Light source lifetime	Up to 20,000hrs
Sealed DLP™ core	Yes
Orientation	360° rotation, no restrictions
3D	Active stereoscopic 3D
Image processing	Embedded warp & blend possible via Ptoolset
Keystone correction	Yes
Inputs	2x HDMI 1.4 / DVI-D / HDBaseT / 3G-SDI / VGA (D-Sub 15 pin) / RJ 45 Ethernet / RS232 in
Input resolutions	Up to 1,920 x 1,200 @ 60Hz refresh rates: 24Hz to 120Hz for 720p (1280x720) and 24Hz to 60Hz for WUXGA (1920x1200)
Software tools	Projector Toolset

Control	IR, RS232, RJ45, 3.5mm phone jack for wired remote
Network connection	10/100 Ethernet, RJ45
Power requirements	100-240V / 50-60Hz
Power consumption	635W nominal, 730W maximum
BTU per hour	2,170 BTU/h nominal; 2,500 BTU/h maximum
Standby power	less than 0.5W
Noise level (typical at 25°C/ 77°F)	36dB(A) - 40dB(A) depending on the used mode
Operating temperature	5 - 40 °C (sea level)
Storage temperature	-10 to 60 °C
Operating humidity	10 - 85% RH, non-condensing
Storage humidity	5 - 90% RH, non-condensing
Dimensions (WxLxH)	without feet: 484 x 529 x 195 mm / 19.06 x 20.83 x 7.68 in
Weight	without lens: 17.4 kg / 38.4 lbs
Standard accessories	Power cord, wireless remote control
Certifications	CE, FCC Class A, cTUVUS, CCC, EAC, KCC, RCM, BIS, BSMI
Warranty	Limited 3 years parts and labor

A.3 Product specification of the G60-W10

Specifications

Projector type	Single chip DLP laser phosphor projector
Resolution	1,920 x 1,200 (WUXGA)
Brightness	9,000 ANSI lumens 9,500 center lumens 10,200 ISO lumens
Contrast ratio	1,200:1 sequential; 6,000:1 dynamic; Extreme black: 100,000:1
Brightness uniformity	85%
Aspect ratio	16:10
Lens type	G-lenses - 0.36:1 / 0.75-0.95:1 / 0.95-1.22:1 / 1.22-1.52:1 / 1.52-2.92:1 / 2.90-5.50:1
Optical lens shift	Vertical up to 100%, depending on lens Horizontal up to 30%, depending on lens Motorized zoom and focus Motorized lens shift
Color correction	Yes
CLO (constant light output)	Yes
Light source	Laser phosphor
Light source lifetime	Up to 20,000hrs
Sealed DLP™ core	Yes
Orientation	360° rotation, no restrictions

3D	Active stereoscopic 3D
Image processing	Embedded warp & blend possible via Ptoolset
Keystone correction	Yes
Inputs	2x HDMI 1.4 / DVI-D / HDBaseT / 3G-SDI / VGA (D-Sub 15 pin) / RJ 45 Ethernet / RS232 in
Input resolutions	Up to 1,920 x 1,200 @ 60Hz refresh rates: 24Hz to 120Hz for 720p (1280x720) and 24Hz to 60Hz for WUXGA (1920x1200)
Software tools	Projector Toolset
Control	IR, RS232, RJ45, 3.5mm phone jack for wired remote
Network connection	10/100 Ethernet, RJ45
Power requirements	100-240V / 50-60Hz
Power consumption	935W nominal, 1080W maximum
BTU per hour	3,190 BTU/h nominal; 3,690 BTU/h maximum
Standby power	less than 0.5W
Noise level (typical at 25°C/ 77°F)	36dB(A) - 40dB(A) depending on the used mode
Operating temperature	5 - 40 °C (sea level)
Storage temperature	-10 to 60 °C
Operating humidity	10 - 85% RH, non-condensing
Storage humidity	5 - 90% RH, non-condensing
Dimensions (WxLxH)	without feet: 484 x 529 x 195 mm / 19.06 x 20.83 x 7.68 in
Weight	without lens: 22.7 kg / 50.1 lbs
Standard accessories	Power cord, wireless remote control
Certifications	CE, FCC Class A, cTUVUS, CCC, EAC, KCC, RCM, BIS, BSMI
Warranty	Limited 3 years parts and labor

A.4 Compatibility modes

Timing table

Signal type	Resolution	Frame rate (Hz)	VGA	HDMI1/2	DVI	HDBaseT	3G-SDI
PC	640x350	85		V	V	V	
	640x400	85	V	V	V	V	
	640x480	59		V	V	V	
	640x480	60	V	V	V	V	
	640x480	72	V	V	V	V	
	640x480	75	V	V	V	V	
	640x480	85	V	V	V	V	
	720x400	60	V	V	V	V	
	720x400	85	V				

Signal type	Resolution	Frame rate (Hz)	VGA	HDMI1/2	DVI	HDBa-seT	3G-SDI
	768x480	60		V	V	V	
	768x480	75		V	V	V	
	768x480	85		V	V	V	
	800x600	50		V	V	V	
	800x600	56	V	V	V	V	
	800x600	60	V	V	V	V	
	800x600	72	V	V	V	V	
	800x600	75	V	V	V	V	
	800x600	85	V	V	V	V	
	848x480	50		V	V	V	
	848x480	60		V	V	V	
	848x480	75		V	V	V	
	848x480	85		V	V	V	
	960x600	50		V	V	V	
	960x600	60		V	V	V	
	960x600	75		V	V	V	
	960x600	85		V	V	V	
	1024x768	60	V	V	V	V	
	1024x768	75	V	V	V	V	
	1024x768	85	V	V	V	V	
	1024x768	120	V	V	V	V	
	1064x600	50		V	V	V	
	1064x600	60		V	V	V	
	1064x600	75		V	V	V	
	1064x600	85		V	V	V	
	1152x720	50		V	V	V	
	1152x720	60		V	V	V	
	1152x720	75		V	V	V	
	1152x720	85		V	V	V	
	1152x864	60	V	V	V	V	
	1152x864	70	V	V	V	V	
	1152x864	75	V	V	V	V	
	1152x864	85	V	V	V	V	
	1224x768	50		V	V	V	
	1224x768	60		V	V	V	
	1224x768	85		V	V	V	
	1280x720	50		V	V	V	
	1280x720	60	V	V	V	V	
	1280x720	75	V	V	V	V	
	1280x720	85	V	V	V	V	
	1280x720	120		V	V	V	
	1280x768	60	V	V	V	V	
	1280x768	75	V	V	V	V	
	1280x768	85	V	V	V	V	
	1280x800	50	V	V	V	V	
	1280x800	60	V	V	V	V	
	1280x800	75	V	V	V	V	
	1280x800	85	V	V	V	V	
	1280x960	50		V	V	V	
	1280x960	60	V	V	V	V	
	1280x960	75	V	V	V	V	
	1280x960	85	V	V	V	V	

Signal type	Resolution	Frame rate (Hz)	VGA	HDMI1/2	DVI	HDBa-seT	3G-SDI
	1280x1024	50		V	V	V	
	1280x1024	60	V	V	V	V	
	1280x1024	75	V	V	V	V	
	1280x1024	85	V	V	V	V	
	1360x768	50		V	V	V	
	1360x768	60		V	V	V	
	1360x768	75		V	V	V	
	1360x768	85		V	V	V	
	1366x768	60	V	V	V	V	
	1400x900	60	V		V		
	1400x1050	50		V	V	V	
	1400x1050	60	V	V	V	V	
	1400x1050	75	V	V	V	V	
	1440x900	60	V	V	V	V	
	1440x900	75		V	V	V	
	1600x900	60		V	V	V	
	1600x1200	50		V	V	V	
	1600x1200	60	V	V	V	V	
	1680x1050	50		V	V	V	
	1680x1050	60	V	V	V	V	
	1704x960	50		V	V	V	
	1704x960	60		V	V	V	
	1728x1080	50		V	V	V	
	1728x1080	60		V	V	V	
	1864x1050	50		V	V	V	
	1864x1050	60		V	V	V	
	1920X1080	50		V	V	V	
	1920X1080	60	V	V	V	V	
	1920X1200RB	60	V	V	V	V	
	1920X1200RB	50	V	V	V	V	
SDTV	480i	60	V	V	V	V	
	576i	50	V	V	V	V	
EDTV	480p	60	V	V	V	V	
	576p	50	V	V	V	V	
HDTV	1080i	25	V	V	V	V	
	1080i	29	V	V	V	V	
	1080i	30	V	V	V	V	
	720p	50	V	V	V	V	
	720p	59	V	V	V	V	
	720p	60	V	V	V	V	
	1080s	23			V		
	1080s	24			V		
	1080p	23	V	V	V	V	
	1080p	24	V	V	V	V	
	1080p	25	V	V	V	V	
	1080p	29	V	V	V	V	
	1080p	30	V	V	V	V	
	1080p	50	V	V	V	V	
	1080p	59	V	V	V	V	
	1080p	60	V	V	V	V	

Signal type	Resolution	Frame rate (Hz)	VGA	HDMI1/2	DVI	HDBaseT	3G-SDI
Mandatory 3D	Frame Packing 1080p	24		V	V	V	
	Frame Packing 720p	50		V	V	V	
		60		V	V	V	
	Side by Side 1080i	50		V	V	V	
		60		V	V	V	
	Top and Bottom 720p	50		V	V	V	
60			V	V	V		
Top and Bottom 1080p	24		V	V	V		
Frame Sequential 3D (single and multiple)	800x600	120		V	V	V	
	1024x768	120		V	V	V	
	1280x720	120		V	V	V	
SD-SDI	480i YcbCr422 10bit	59.94					V
	576i YcbCr422 10bit	50					V
HD-SDI	720p Ycb-Cr422 10bit	50					V
	720p Ycb-Cr422 10bit	59.94					V
	720p Ycb-Cr422 10bit	60					V
	1080i Ycb-Cr422 10bit	50					V
	1080i Ycb-Cr422 10bit	59.94					V
	1080i Ycb-Cr422 10bit	60					V
	1080p Ycb-Cr422 10bit	23.98					V
	1080p Ycb-Cr422 10bit	24					V
	1080p Ycb-Cr422 10bit	25					V
	1080p Ycb-Cr422 10bit	29.97					V
	1080p Ycb-Cr422 10bit	30					V
	1080sF Ycb-Cr422 10bit	25					V
	1080sF Ycb-Cr422 10bit	29.97					V
	1080sF Ycb-Cr422 10bit	30					V
3GA-SDI	1080p Ycb-Cr422 10bit	50					V
		59.94					V
		60					V
3GB-SDI	1080p Ycb-Cr422 10bit With 352M Payload ID	50					V
		59.94					V
		60					V

PIP/PBP Compatibility

PIP/PBP Matrix	VGA	DVI-D	HDMI-1	HDMI-2	3G-SDI	HDBaseT
VGA		V	V	V	V	V
DVI-D	V		V	V	V	V
HDMI-1	V	V		V	V	V
HDMI-2	V	V	V		V	V

PIP/PBP Matrix	VGA	DVI-D	HDMI-1	HDMI-2	3G-SDI	HDBaseT
3G-SDI	V	V	V	V		V
HDBaseT	V	V	V	V	V	



PIP/PBP does not support 3D input.

A.5 Dimensions of the G60



CAUTION: Avoid installing the projector near a heat source.

Front view

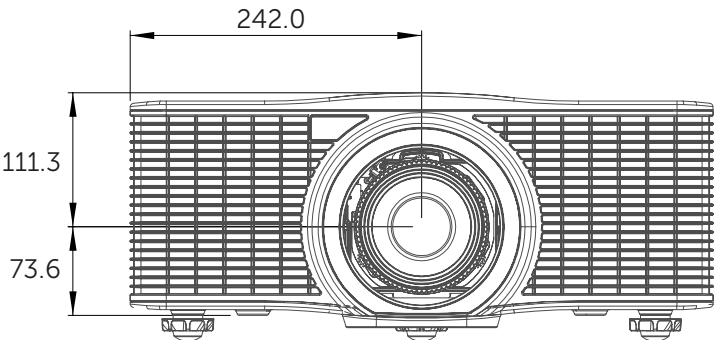

Image A-1: Dimensions given in millimeters.

Rear view

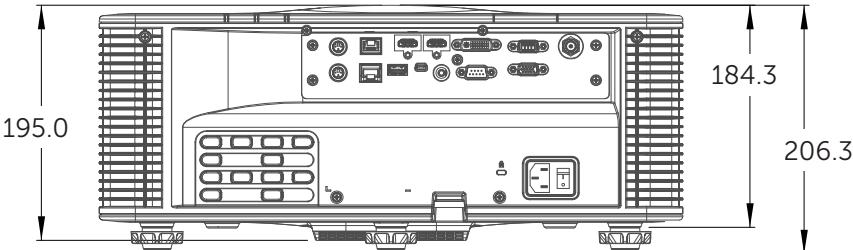

Image A-2: Dimensions given in millimeters.

Top view

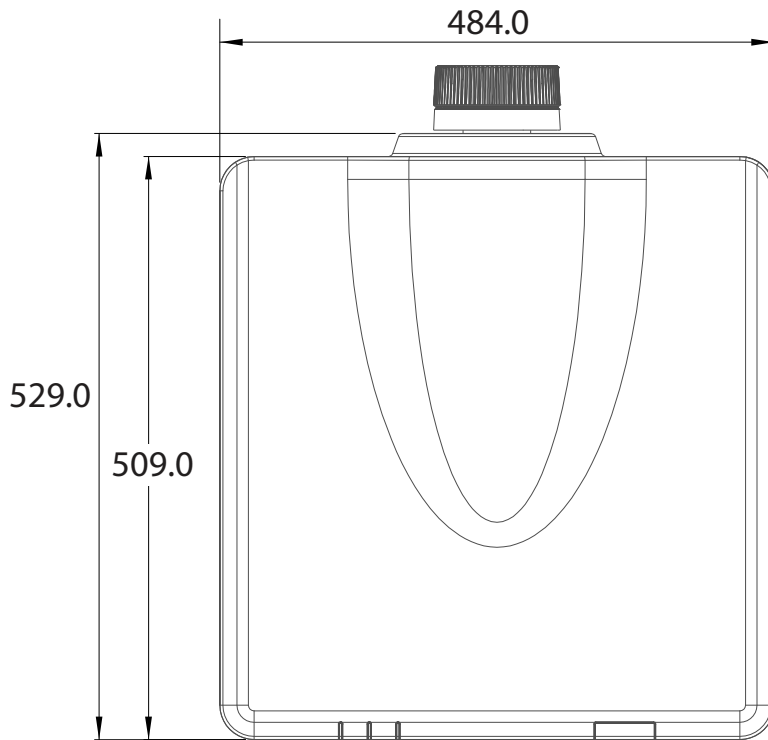

Image A-3: Dimensions given in millimeters.

A.6 Ceiling mount

About ceiling mount



CAUTION: Be sure to use the correct screw size. Screw Length will vary depending on the thickness of the mounting plate.



CAUTION: Be sure to keep at least 30 mm gap between the ceiling and the bottom of the projector.

Projector mounting holes

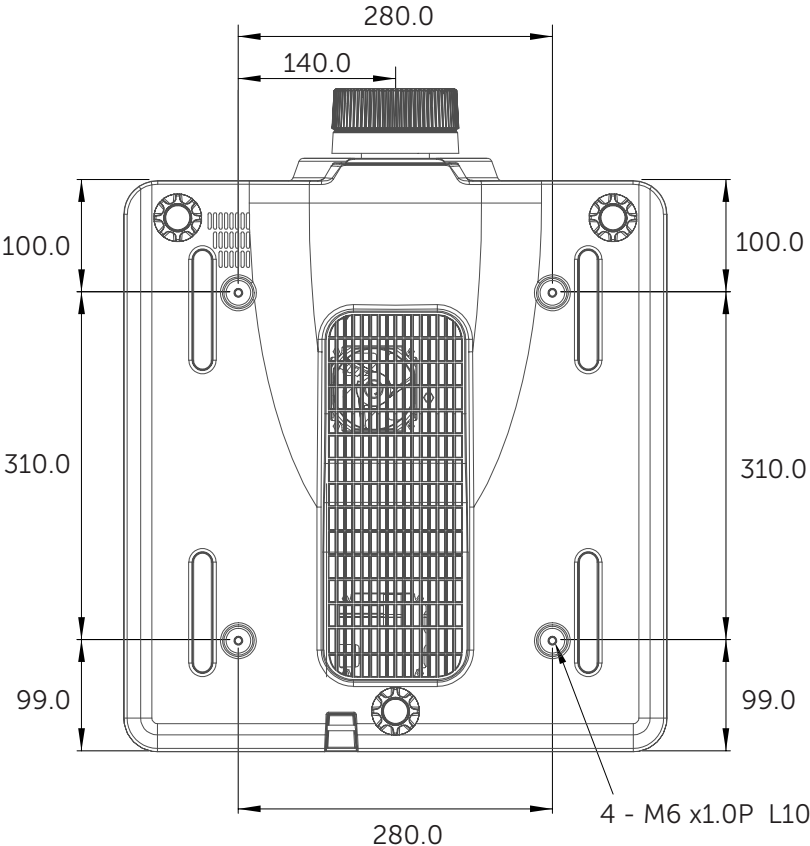

Image A-4: Dimensions given in millimeters.

Environmental information

B

Overview

- [China RoHS compliance](#)
- [Taiwan RoHS compliance](#)
- [Turkey RoHS compliance](#)
- [Disposal information](#)
- [Production address](#)
- [Contact information](#)
- [Download Product Manual](#)

B.1 China RoHS compliance

中国大陆 RoHS (Information for China ROHS compliance)

根据中国大陆《电器电子产品有害物质限制使用管理办法》（也称为中国大陆RoHS），以下部分列出了Barco产品中可能包含的有毒和/或有害物质的名称和含量。中国大陆RoHS指令包含在中国信息产业部MCV标准：“电子信息产品中有毒物质的限量要求”中。

According to the “Management Methods for the Restriction of the Use of Hazardous Substances in Electrical and Electronic Products” (Also called RoHS of Chinese Mainland), the table below lists the names and contents of toxic and/or hazardous substances that Barco’s product may contain. The RoHS of Chinese Mainland is included in the MCV standard of the Ministry of Information Industry of China, in the section “Limit Requirements of toxic substances in Electronic Information Products”.

零件项目(名称) Component name	有毒有害物质或元素 Hazardous substances and elements					
	铅 (Pb)	汞 (Hg)	镉 (Cd)	六价铬 (Cr6+)	多溴联苯 (PBB)	多溴二苯醚 (PBDE)
外壳 Shell	X	O	X	O	O	O
主板 Motherboard	X	O	O	O	O	O
引擎模块 Engine module	X	O	O	O	O	O
雷射光源模组 Laser light source module	X	O	O	O	O	O
风扇 Fan	X	O	O	O	O	O
铁件 Iron frame	X	O	O	O	O	O
线材 Wire	X	O	X	O	O	O
遥控器 Remote control	X	O	O	O	O	O
包装 Package	O	O	O	O	O	O

本表格依据SJ/T 11364的规定编制

This table is prepared in accordance with the provisions of SJ/T 11364.

O: 表示该有毒有害物质在该部件所有均质材料中的含量均在 GB/T 26572 标准规定的限量要求以下。

O: Indicates that this toxic or hazardous substance contained in all of the homogeneous materials for this part is below the limit requirement in GB/T 26572.

X: 表示该有毒有害物质至少在该部件的某一均质材料中的含量超出 GB/T 26572 标准规定的限量要求。

X: Indicates that this toxic or hazardous substance contained in at least one of the homogeneous materials used for this part is above the limit requirement in GB/T 26572.



在中国大陆销售的相应电子信息产品（EIP）都必须遵照中国大陆《电子电气产品有害物质限制使用标识要求》标准贴上环保使用期限（EFUP）标签。Barco产品所采用的EFUP标签（请参阅实例，徽标内部的编号使用于指定产品）基于中国大陆的《电子信息产品环保使用期限通则》标准。

All Electronic Information Products (EIP) that are sold within Chinese Mainland must comply with the “Marking for the restriction of the use of hazardous substances in electrical and electronic product” of Chinese Mainland, marked with the Environmental Friendly Use Period (EFUP) logo. The number inside the EFUP logo that Barco uses (please refer to the photo) is based on the “General guidelines of environment-friendly use period of electronic information products” of Chinese Mainland.

B.2 Taiwan RoHS compliance

限用物質含有情況標示聲明書 (Declaration of the Presence Condition of the Restricted Substances Marking)

單元 Unit	限用物質及其化學符號 Restricted substances and its chemical symbols					
	鉛 Lead (Pb)	汞 Mercury (Hg)	鎘 Cadmium (Cd)	六價鉻 Hexavalent chromium (Cr6+)	多溴聯苯 Polybrominated biphenyls (PBB)	多溴二苯醚 Polybrominated diphenyl ethers (PBDE)
塑膠外殼 Plastic shell	—	○	○	○	○	○
電源供應器 Power supply	—	○	○	○	○	○
印刷電路板 Printed circuit board	—	○	○	○	○	○
絕緣墊片 Insulating gasket	○	○	○	○	○	○
光學鏡片 Optical lenses	—	○	○	○	○	○
雷射模組 Laser module	—	○	○	○	○	○
風扇模組 Fan module	—	○	○	○	○	○
鐵件 Iron frame	—	○	○	○	○	○
線材 wire (interlock switch/power cord)	—	○	—	○	○	○
喇叭 Speaker	—	○	○	○	○	○
馬達 Motor	—	○	○	○	○	○
自復式保險絲 Resettable fuse (polyswitch)	○	○	○	○	○	○

	限用物質及其化學符號 Restricted substances and its chemical symbols					
單元 Unit	鉛 Lead (Pb)	汞 Mercury (Hg)	鎘 Cadmium (Cd)	六價鉻 Hexavalent chromium (Cr6+)	多溴聯苯 Polybrominated biphenyls (PBB)	多溴二苯醚 Polybrominated diphenyl ethers (PBDE)
配件 (如:遙控器等) Accessories (remote control, etc.)	—	○	○	○	○	○
<p>備考1. “超出0.1 wt %”及“超出0.01 wt %”係指限用物質之百分比含量超出百分比含量基準值。 Note 1 : “Exceeding 0.1 wt %” and “exceeding 0.01 wt %” indicate that the percentage content of the restricted substance exceeds the reference percentage value of presence condition.</p> <p>備考2. “○”係指該項限用物質之百分比含量未超出百分比含量基準值。 Note 2 : “○” indicates that the percentage content of the restricted substance does not exceed the percentage of reference value of presence.</p> <p>備考3. “—”係指該項限用物質為排除項目。 Note 3 : The “—” indicates that the restricted substance corresponds to the exemption.</p>						

備註: 此RoHS表格適用於以下產品型號: G60-W7, G60-W8, G60-W10

Hint: This RoHS table is suitable for following models: G60-W7, G60-W8, G60-W10

B.3 Turkey RoHS compliance

Turkey RoHS compliance



■ Türkiye Cumhuriyeti: AEEE Yönetmeliğine Uygundur.

[Republic of Turkey: In conformity with the WEEE Regulation]

B.4 Disposal information

Disposal Information

Waste Electrical and Electronic Equipment



■ This symbol on the product indicates that, under the European Directive 2012/19/EU governing waste from electrical and electronic equipment, this product must not be disposed of with other municipal waste. Please dispose of your waste equipment by handing it over to a designated collection point for the recycling of waste electrical and electronic equipment. To prevent possible harm to the environment or human health from uncontrolled waste disposal, please separate these items from other types of waste and recycle them responsibly to promote the sustainable reuse of material resources.

For more information about recycling of this product, please contact your local city office or your municipal waste disposal service.

For details, please visit the Barco website at: <http://www.barco.com/AboutBarco/weee>

Disposal of batteries in the product



This product contains batteries covered by the Directive 2006/66/EC which must be collected and disposed of separately from municipal waste.

If the battery contains more than the specified values of lead (Pb), mercury (Hg) or cadmium (Cd), these chemical symbols will appear below the crossed-out wheeled bin symbol.

By participating in separate collection of batteries, you will help to ensure proper disposal and to prevent potential negative effects on the environment and human health.

B.5 Production address

Producer

Barco NV (BELGIUM) Entertainment Division
Beneluxpark 21, 8500 Kortrijk, Belgium

Made in information

The made in country is indicated on the product ID label on the product itself.

Production date

The month and year of production is indicated on the product ID label on the product itself.

B.6 Contact information

Barco contact information

Registered office address: President Kennedypark 35, 8500 Kortrijk, Belgium

Contact address: Beneluxpark 21, 8500 Kortrijk, Belgium

Importers contact information

To find your local importer, contact Barco directly or one of Barco's regional offices via the contact information given on Barco's web site, www.barco.com.

B.7 Download Product Manual

Download Product Manual

Product manuals and documentation are available online at www.barco.com/td.

Registration may be required; follow the instructions given on the website.

IMPORTANT! Read Installation Instructions before connecting equipment to the mains power supply.

Glossary

HD

Hazard Distance (HD) is the distance measured from the projection lens at which the intensity or the energy per surface unit becomes lower than the applicable exposure limit on the cornea or on the skin. The light beam is considered (to be) unsafe for exposure if the distance from a person to the light source is less than the HD.

HD

Hazard Distance (HD) is the distance measured from the projection lens at which the intensity or the energy per surface unit becomes lower than the applicable exposure limit on the cornea or on the skin. The light beam is considered (to be) unsafe for exposure if the distance from a person to the light source is less than the HD.

Index

Numbers/Symbols

3D Menu 42

A

Address 69

C

Ceiling mount
Holes 62
Communications Menu 43
Compatibility modes 57
Control panel 22

D

Dimensions 61
Download
Product manual 69

E

Electrical shock 10
Enclosed projection 17
Environmental information 65
Disposal information 68
RoHS compliance
China 66
Taiwan 67
Turkey 68

F

Fire hazard 11

G

General considerations 14
Safety 8

H

Hazard Distance 15, 17
Hazardous Chemicals 13
HD for G60-W10
Safety 9
High Brightness precautions 15

I

Importer 69
Input/Output 21
Instructions
Safety 10

L

Labels
Safety 13
Safety G60-W10 14
Safety G60-W7 13
Safety G60-W8 14
Laser safety precautions G60-W10
Safety 9
Laser safety precautions G60-W7
Safety 8
Laser safety precautions G60-W8
Safety 8
LED Indication chart 50
Light Source Menu 39

M

Main unit 20

N

Network
Controlling projector 44
Notice on safety 8

O

On/Off 25

Options Menu 40
OSD 30

User definition
Safety 10

P

Personal injury 10
Picture Menu 31
Power 25
Power Off 26
Power On 26
Product overview 19
Production 69
Projector damage 11
Projector Problems 51

R

RCU 23
Rear projection 17
RG3 14

S

Safety 7
 Battery explosion 12
 General considerations 8
 Hazard Distance 15, 17
 Hazardous Chemicals 13
 HD for G60-W10 9
 Instructions 10
 Labels 13
 Labels G60-W10 14
 Labels G60-W7 13
 Labels G60-W8 14
 Laser safety precautions G60-W10 9
 Laser safety precautions G60-W7 8
 Laser safety precautions G60-W8 8
 Prevent electrical shock 10
 Prevent fire hazard 11
 Prevent personal injury 10
 Prevent projector damage 11
 Safety Data Sheet (SDS) 13
 Servicing 13
 User definition 10
Safety Data Sheet (SDS) 13
Screen Menu 34
Settings Menu 38
Specifications 53
 G60-W10 56
 G60-W7 54
 G60-W8 55

T

Telnet
 RS232 command 47
Troubleshooting 49

U

User controls 29

W

Web control center 45

