

SFP-10/25G-CSR-S-AO

Cisco® Compatible TAA Compliant 25GBase-SR SFP28 Transceiver (MMF, 850nm, 100m, LC, DOM)

Features

- Support 25.78Gb/s and 10.3Gb/s bi-directional data links
- Electrical interface specifications per SFF-8431
- Management interface specifications per SFF-8432 and SFF-8472
- Build-in CDR with 25.78Gb/s operation
- Up to 100m on OM3 MMF and 300m on OM4 MMF
- SFP28 MSA package with duplex LC connector
- Uncooled 850nm VCSEL Laser
- Single +3.3V power supply
- Class 1 laser safety certified
- Metal enclosure, for lower EMI
- Commercial operating temperature: 0°C to +70°C
- RoHS compliant



Applications

- 25G high speed interconnection
- 10G Ethernet 10GBASE-SR/SW
- Support CPRI rate: 24.3Gb/s

Product Description

This Cisco® compatible SFP28 transceiver provides 25GBase-SR throughput up to 100m over multi-mode fiber (MMF) using a wavelength of 850nm via an LC connector. It is guaranteed to be 100% compatible with the equivalent Cisco® transceiver. This easy to install, hot swappable transceiver has been programmed, uniquely serialized and data-traffic and application tested to ensure that it will initialize and perform identically. Digital optical monitoring (DOM) support is also present to allow access to real-time operating parameters. This transceiver is Trade Agreements Act (TAA) compliant. We stand behind the quality of our products and proudly offer a limited lifetime warranty.

AddOn's SFP28 transceivers are RoHS compliant and lead-free.

TAA refers to the Trade Agreements Act (19 U.S.C. & 2501-2581), which is intended to foster fair and open international trade. TAA requires that the U.S. Government may acquire only "U.S. – made or designated country end products."



Regulatory Compliance

- ESD to the Electrical PINs: compatible with MIL-STD-883E Method 3015.4
- ESD to the LC Receptacle: compatible with IEC 61000-4-3
- EMI/EMC compatible with FCC Part 15 Subpart B Rules, EN55022:2010
- Laser Eye Safety compatible with FDA 21CFR, EN60950-1& EN (IEC) 60825-1,2
- RoHS compliant with EU RoHS 2.0 directive 2015/863/EU

Absolute Maximum Ratings

Parameter	Symbol	Min.	Max.	Unit
Maximum Supply Voltage	V _{CC}	-0.5	4.0	V
Storage Temperature	T _S	-40	85	°C
Operating Case Temperature	T _C	0	70	°C
Operating Humidity	RH	5	85	%
Receiver Power	R _{MAX}		-10.3/-11	dBm
Maximum Bitrate	B _{max}	10.3	25.78	Gbps

Electrical Characteristics (TOP=25°C, V_{CC}=3.3Volts)

Parameter	Symbol	Min.	Typ.	Max.	Unit	Notes
Power Supply Voltage	V _{CC}	3.135	3.3	3.465	V	
Power Supply Current	I _{CC}			290	mA	
Power Consumption	P _D			1000	mW	
Transmitter						
Differential data input swing	V _{in,pp}	180		700	mVp-p	
Input differential impedance	Z _{in}		100		Ω	
Receiver						
Differential data output swing	V _{out, pp}	300		850	mVp-p	
Output differential impedance	Z _o		100		Ω	

Optical Characteristics

Parameter	Symbol	Min.	Typ.	Max.	Unit	Notes
Transmitter						
Launch Optical Power	P _o	-7.6		+2.4	dBm	1
Optical Extinction Ratio	ER	2			dB	
Transmitter and Dispersion Penalty @25.78Gb/s	TWDP			4.3	dB	
Optical Wavelength	Tλ	840	850	860	nm	
Spectral Width (RMS) @25.78Gb/s	Δλ			0.6	nm	
Optical Return Loss Tolerance	ORLT			12	dB	
Pout @TX-Disable Asserted	P _{off}			-30	dBm	1
Receiver						
Receiver Sensitivity (P _{avg})	S			-10.3	dBm	2
Receiver Sensitivity (P _{avg})	S			-11.0	dBm	3
Receiver Overload (P _{avg})	P _{OL}	2.5			dBm	
Receiver wavelength	Rλ	840	850	860	nm	
Optical Return Loss	ORL	12			dB	
LOS De-Assert	LOS _D			-11	dBm	
LOS Assert	LOS _A	-30			dBm	
LOS Hysteresis		0.5			dB	

Notes:

1. 50/125μm fiber with NA = 0.2.
2. Measured with PRBS 231-1 at 5e-5 BER @25.78Gb/s.
3. Measured with PRBS 231-1 at 5e-5 BER @10.3Gb/s.

Pin Descriptions

Pin	Symbol	Name/Descriptions	Ref.
1	VeeT	Transmitter Ground (Common with Receiver Ground).	1
2	TX Fault	Transmitter Fault. LVTTTL-O	2
3	TX Disable	Transmitter Disable. Laser output disabled on high or open. LVTTT-I.	3
4	SDA	2-Wire Serial Interface Data Line (Same as MOD-DEF2 in INF-8074i). LVTTTL-I/O.	
5	SCL	2-Wire Serial Interface Data Line (Same as MOD-DEF2 in INF-8074i). LVTTTL-I.	
6	MOD_ABS	Module Absent, Connect to VeeT or VeeR in Module.	4
7	RS0	Rate Select 0, optionally controls SFP28 module receiver LVTTTL-I.	5
8	LOS	Loss of Signal indication. Logic 0 indicates normal operation. LVTTTL-O.	2
9	RS1	Rate Select 1, optionally controls SFP28 module transmitter. LVTTTL-I.	5
10	VeeR	Receiver Ground (Common with Transmitter Ground).	1
11	VeeR	Receiver Ground (Common with Transmitter Ground).	1
12	RD-	Receiver Inverted DATA out. AC Coupled. CML-O.	
13	RD+	Receiver Non-inverted DATA out. AC Coupled. CML-O.	
14	VeeR	Receiver Ground (Common with Transmitter Ground).	1
15	VccR	Receiver Power Supply.	
16	VccT	Transmitter Power Supply.	
17	VeeT	Transmitter Ground (Common with Receiver Ground).	1
18	TD+	Transmitter Non-Inverted DATA in. AC Coupled. CML-I.	
19	TD-	Transmitter Inverted DATA in. AC Coupled. CML-O.	
20	VeeT	Transmitter Ground (Common with Receiver Ground).	1

Notes:

1. The module signal ground contacts, VeeR and VeeT, should be isolated from the module case.
2. This contact is an open collector/drain output and should be pulled up to the Vcc_Host with resistor in the range 4.7KΩ to 10KΩ. Pull ups can be connected to one or several power supplies, however the host board design shall ensure that no module contract has voltage exceeding module VccT/R +0.5.V.
3. Tx_Disable is an input contact with a 4.7KΩ to 10KΩ pull-up resistor to VccT inside module.
4. Mod_ABS is connected to VeeT or VeeR in the SFP28 module. The host may pull the contract up to Vcc_Host with a resistor in the range from 4.7KΩ to 10KΩ. Mod_ABS is asserted “High” when the SFP28 module is physically absent from a host slot.
5. RS0 and RS1 are module inputs and are pulled low to VeeT with >30K resistors in the module. RS0 optionally selects the optical receive signaling rate coverage. RS1 optionally selects the optical transmit signaling rate coverage.

These contacts can also be used for RS0 and RS1 if implementing SFF8079. See SFF8079 for details. RS1 is commonly connected to VeeT or VeeR in the classic SFP modules. The host needs to ensure that it will

not be damaged if this contact is connected to VeeT or VeeR in the module.

The SFP28 module provides two inputs RS0 and RS1 that can optionally be used for rate selection. RS0 controls the receive path signaling rate compatibility, and RS1 controls the transmit path signaling rate compatibility. The host and module may choose to use either, both, or none of these functions. Because contact 9 in the classic SFP INF-8074i is connected to VeeR, and SFP28 host utilizing RS1 must provide short circuit protection.

This rate select functionality can also be controlled by software as defined by SFF-8472. Optionally the rate select methods of Part 2 SFF-8079 may be used instead of the method described here by setting the management declaration bit (A0h byte 93 bit 2) to 1, see SFF-8472.

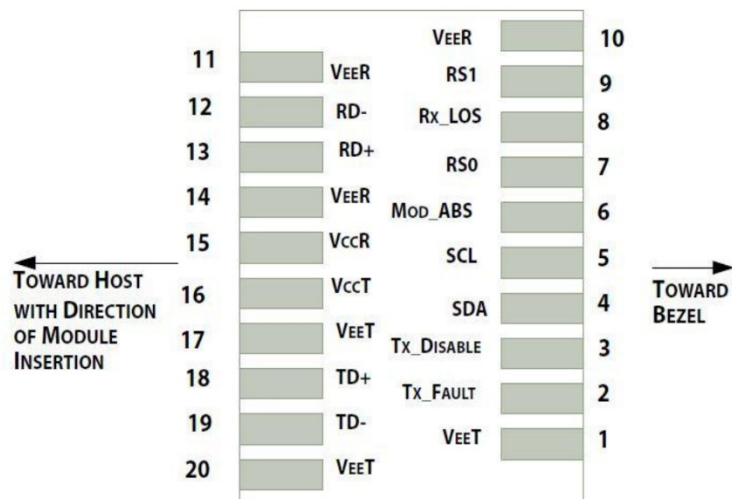

Pin-out of connector Block on Host board

Recommended Application Interface Block Diagram

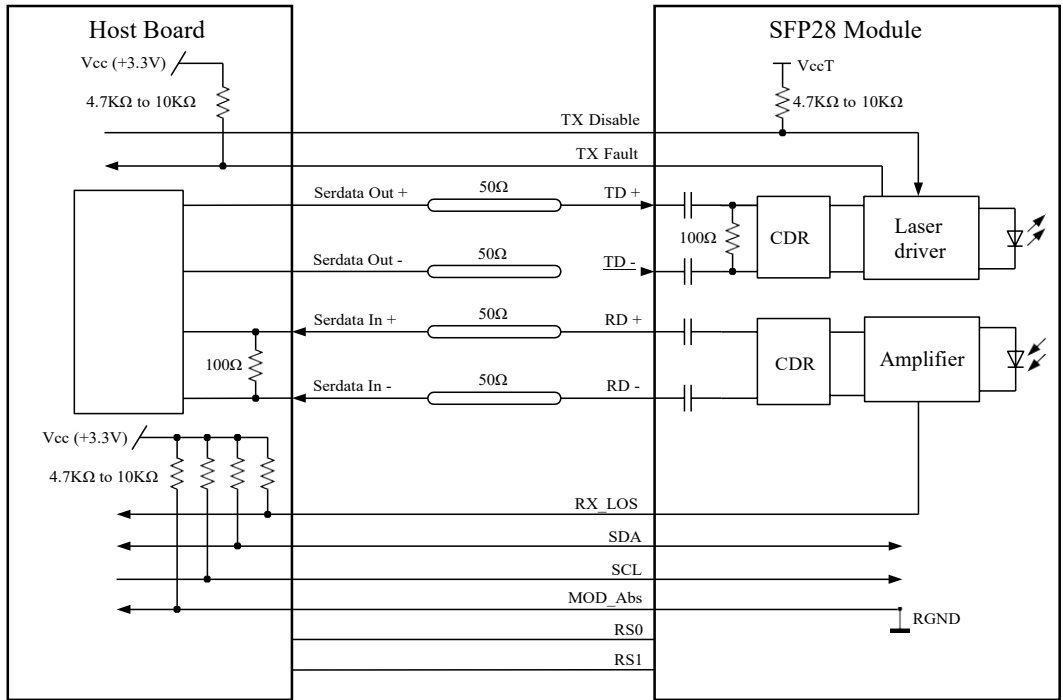

Mechanical Specifications

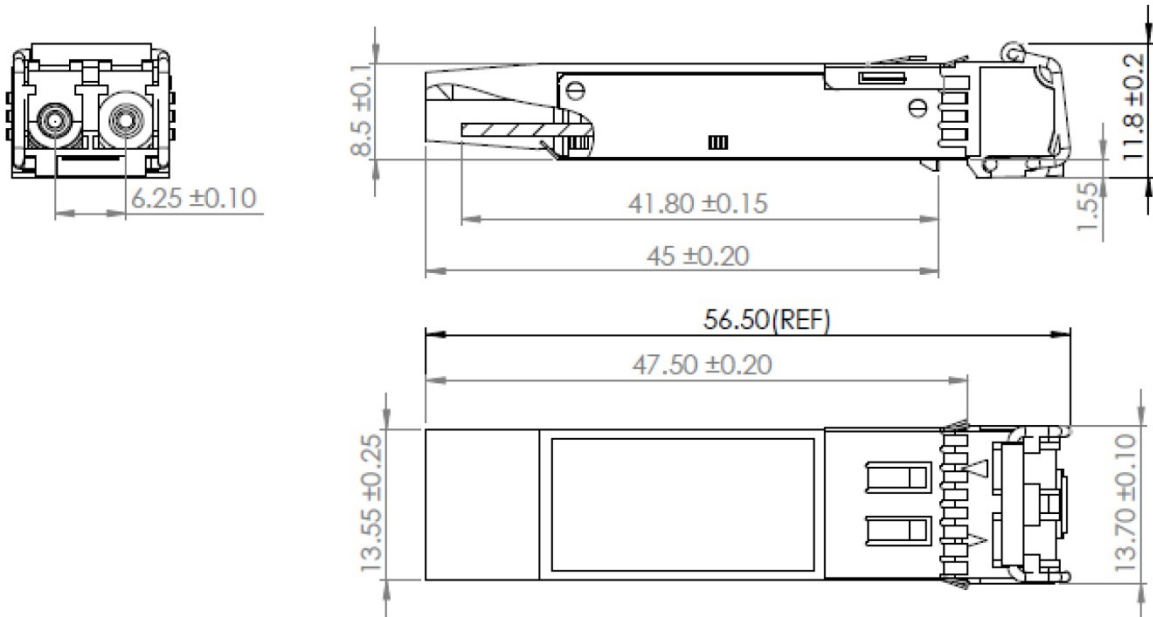

EEPROM Information

EEPROM memory map specific data field description is as below:

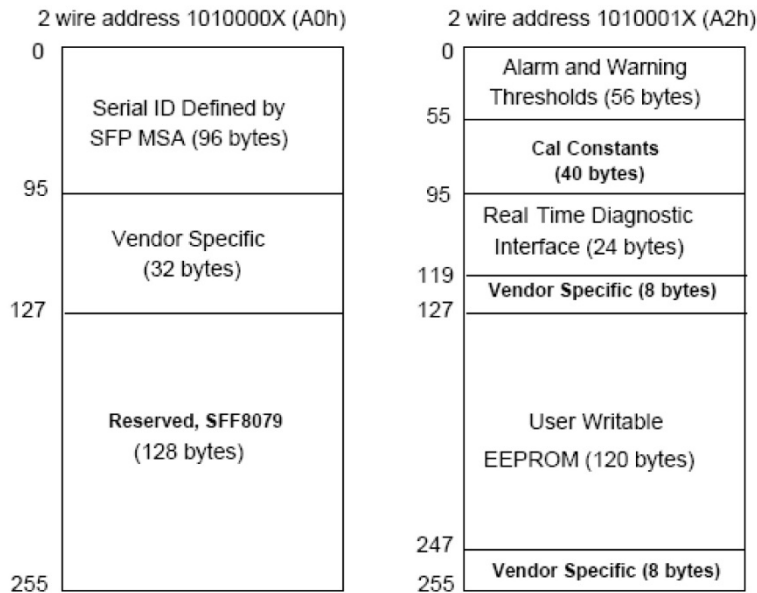

Contact Information

Founded in 1999, AddOn Networks is North America’s leading provider of transceivers and high speed cabling. With a reputation for high quality products as well as an extensive custom design portfolio, AddOn has the connectivity solution regardless of the requirement.

At AddOn, 100% of the products we ship every day are tested in the specific application for which they are intended—never batch or spec tested only. We run bandwidth, distance and IOS network tests. We have documented an impressive 0.03% failure rate over the last 10 years. To continue this rate of success we invest millions annually in our own on-site testing lab.

Corporate office:
AddOn Networks
15775 Gateway Circle
Tustin, CA 92780

Tel: 877-292-1701
Fax: 949-266-9273
Email: sales@addonnetworks.com
Email: support@addonnetworks.com
Web: <http://www.addonnetworks.com>