

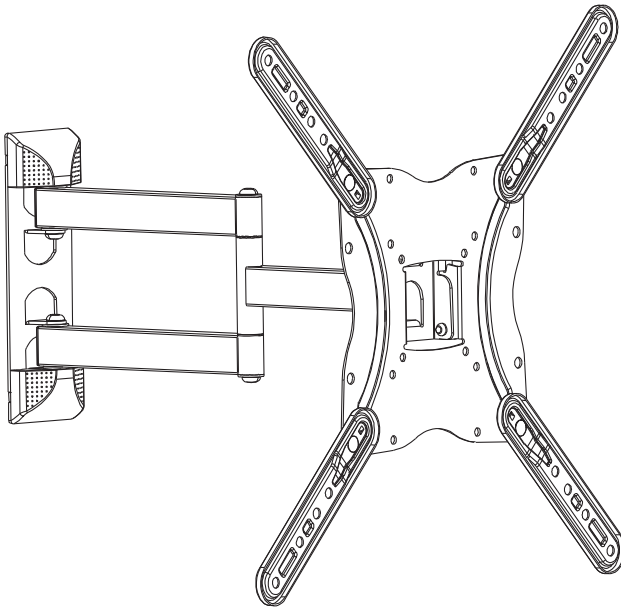

23"-55" Articulating TV Wall Mount Bracket



CAUTION: DO NOT EXCEED RATED LISTED WEIGHT. SERIOUS INJURY OR PROPERTY DAMAGE MAY OCCUR!

650407

VESA

75x75 100x100
200x100 200x200
300x300 400x400

MOST

23" - 55"

TVs



30kg/66lbs

INSTALLATION MANUAL

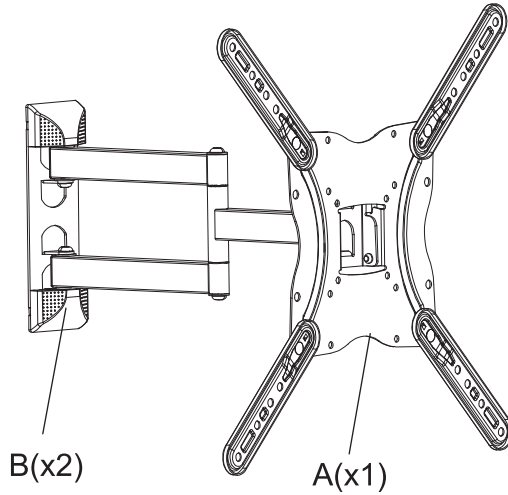

M4x14 (x4)
M-A

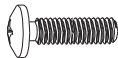

M5x14 (x4)
M-B

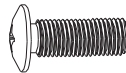

M6x14 (x4)
M-C

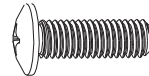

M8x20 (x4)
M-D



M-E(x8)



callback ring (x1)
M-F



J(x4)



K(x4)



L(x4)

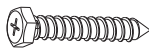

W-A(x4)

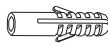

W-B(x4)



W-C(x4)

1.1

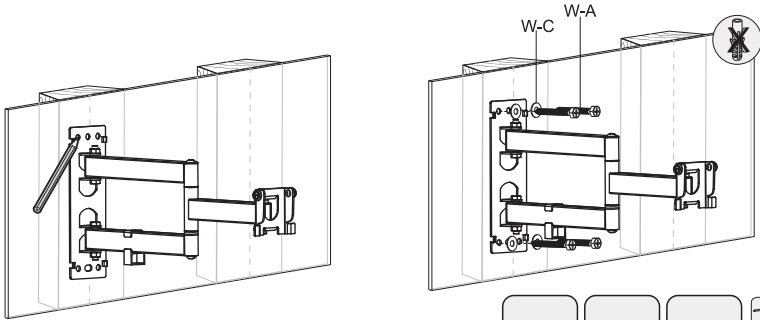
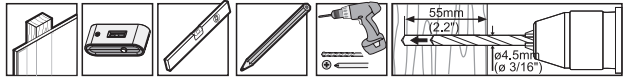

1.2

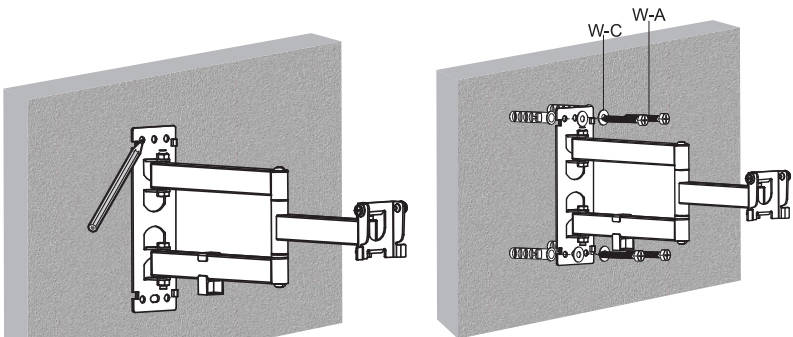

2.

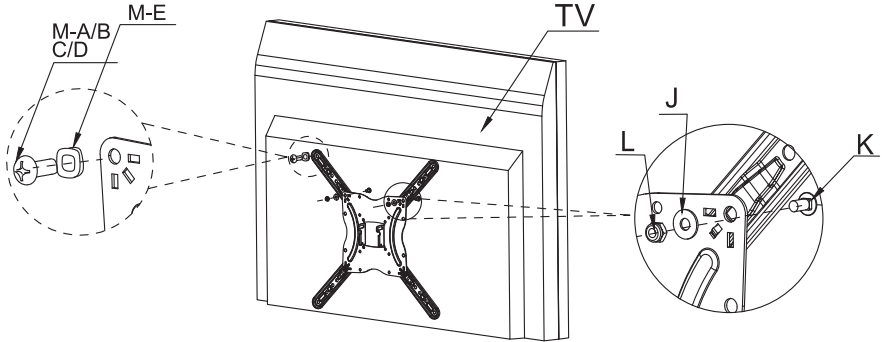
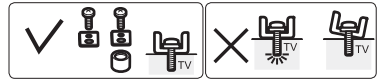

3.1

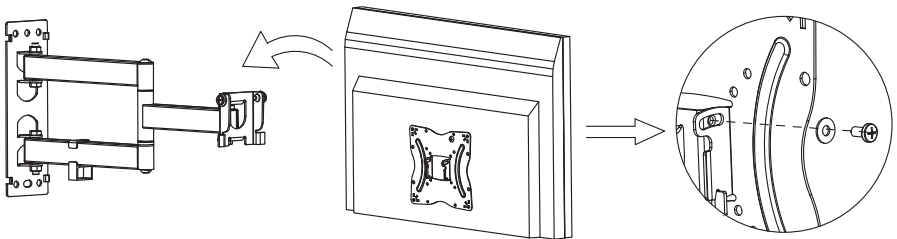

3.2

