



# PE5100D Series

## Embedded Computer

User Manual



**E25145**

**Revised Edition V2**

**September 2024**

## **COPYRIGHT INFORMATION**

No part of this manual, including the products and software described in it, may be reproduced, transmitted, transcribed, stored in a retrieval system, or translated into any language in any form or by any means, except documentation kept by the purchaser for backup purposes, without the express written permission of ASUSTeK COMPUTER INC. ("ASUS").

ASUS PROVIDES THIS MANUAL "AS IS" WITHOUT WARRANTY OF ANY KIND, EITHER EXPRESS OR IMPLIED, INCLUDING BUT NOT LIMITED TO THE IMPLIED WARRANTIES OR CONDITIONS OF MERCHANTABILITY OR FITNESS FOR A PARTICULAR PURPOSE. IN NO EVENT SHALL ASUS, ITS DIRECTORS, OFFICERS, EMPLOYEES OR AGENTS BE LIABLE FOR ANY INDIRECT, SPECIAL, INCIDENTAL, OR CONSEQUENTIAL DAMAGES (INCLUDING DAMAGES FOR LOSS OF PROFITS, LOSS OF BUSINESS, LOSS OF USE OR DATA, INTERRUPTION OF BUSINESS AND THE LIKE), EVEN IF ASUS HAS BEEN ADVISED OF THE POSSIBILITY OF SUCH DAMAGES ARISING FROM ANY DEFECT OR ERROR IN THIS MANUAL OR PRODUCT.

Products and corporate names appearing in this manual may or may not be registered trademarks or copyrights of their respective companies, and are used only for identification or explanation and to the owners' benefit, without intent to infringe.

SPECIFICATIONS AND INFORMATION CONTAINED IN THIS MANUAL ARE FURNISHED FOR INFORMATIONAL USE ONLY, AND ARE SUBJECT TO CHANGE AT ANY TIME WITHOUT NOTICE, AND SHOULD NOT BE CONSTRUED AS A COMMITMENT BY ASUS. ASUS ASSUMES NO RESPONSIBILITY OR LIABILITY FOR ANY ERRORS OR INACCURACIES THAT MAY APPEAR IN THIS MANUAL, INCLUDING THE PRODUCTS AND SOFTWARE DESCRIBED IN IT.

Copyright © 2024 ASUSTeK COMPUTER INC. All Rights Reserved.

## **LIMITATION OF LIABILITY**

Circumstances may arise where because of a default on ASUS' part or other liability, you are entitled to recover damages from ASUS. In each such instance, regardless of the basis on which you are entitled to claim damages from ASUS, ASUS is liable for no more than damages for bodily injury (including death) and damage to real property and tangible personal property; or any other actual and direct damages resulted from omission or failure of performing legal duties under this Warranty Statement, up to the listed contract price of each product.

ASUS will only be responsible for or indemnify you for loss, damages or claims based in contract, tort or infringement under this Warranty Statement.

This limit also applies to ASUS' suppliers and its reseller. It is the maximum for which ASUS, its suppliers, and your reseller are collectively responsible.

UNDER NO CIRCUMSTANCES IS ASUS LIABLE FOR ANY OF THE FOLLOWING: (1) THIRD-PARTY CLAIMS AGAINST YOU FOR DAMAGES; (2) LOSS OF, OR DAMAGE TO, YOUR RECORDS OR DATA; OR (3) SPECIAL, INCIDENTAL, OR INDIRECT DAMAGES OR FOR ANY ECONOMIC CONSEQUENTIAL DAMAGES (INCLUDING LOST PROFITS OR SAVINGS), EVEN IF ASUS, ITS SUPPLIERS OR YOUR RESELLER IS INFORMED OF THEIR POSSIBILITY.

## **SERVICE AND SUPPORT**

Visit our multi-language website at <https://www.asus.com/support/>.

# Contents

Package contents .....	7
------------------------	---

## Chapter 1: Getting to know your Embedded Computer

1.1 Features .....	10
1.1.1 Front view .....	10
1.1.2 Rear view .....	15
1.1.3 Left view .....	18
1.1.4 Right view .....	18
1.2 Motherboard Overview .....	19
1.2.1 Motherboard layout .....	19
1.2.2 Onboard jumpers .....	21
1.2.3 Internal connectors .....	23

## Chapter 2: Using your Embedded Computer

2.1 Getting started .....	34
2.1.1 Connect the AC power adapter to your Embedded Computer .....	34
2.1.2 Connect a display panel to your Embedded Computer .....	36
2.1.3 Connect the USB cable from keyboard or mouse .....	38
2.1.4 Turn on your Embedded Computer .....	39
2.2 Turning off your Embedded Computer .....	40
2.3 Installing wall mount brackets .....	41

## Chapter 3: Upgrading your Embedded Computer

3.1 Installing a storage device .....	44
3.2 Removing the bottom cover .....	45
3.3 Replacing the bottom cover .....	47
3.4 Removing the heat spreader .....	48
3.5 Installing memory modules .....	51
3.6 Installing an M.2 SSD module to the M.2 M-key slot .....	52
3.7 Installing a wireless card to the M.2 E-key slot .....	53
3.8 Installing a cellular network module to the M.2 B-key slot .....	55
3.9 Installing an mPCIe module .....	60
3.10 Installing a nano SIM card .....	61
3.11 Installing antennas (optional) .....	63

## **Chapter 4: Watchdog Timer**

4.1 Watchdog Timer implementation.....	68
4.2 Watchdog Timer programming .....	69

## **Appendix**

Safety information.....	74
Setting up your system .....	74
Care during use.....	75
Regulatory notices .....	77
Service and Support .....	88

# About this manual

This manual provides information about the hardware and software features of your Embedded Computer, organized through the following chapters:

## **Chapter 1: Getting to know your Embedded Computer**

This chapter details the hardware components of your Embedded Computer.

## **Chapter 2: Using your Embedded Computer**

This chapter provides you with information on using your Embedded Computer.

## **Chapter 3: Upgrading your Embedded Computer**

This chapter provides you with information on how to upgrade the memory modules, wireless modules, and hard disk drive / solid state drive of your Embedded Computer.

## **Chapter 4: Watchdog Timer**

This chapter will guide you in implementing and programming the Watchdog Timer to allow you to monitor and manage system reliability.

## **Appendix**

This section includes notices and safety statements for your Embedded Computer.

## Conventions used in this manual

To highlight key information in this manual, some text are presented as follows:

---

**IMPORTANT!** This message contains vital information that must be followed to complete a task.

---

---

**NOTE:** This message contains additional information and tips that can help complete tasks.

---

---

**WARNING!** This message contains important information that must be followed to keep you safe while performing certain tasks and prevent damage to your Embedded Computer's data and components.

---

# Package contents

Your Embedded Computer package contains the following items:

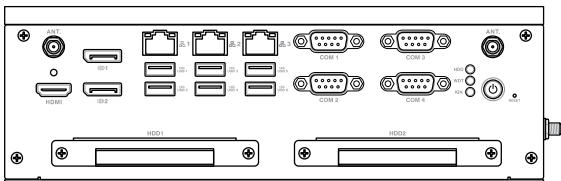

PE5100D

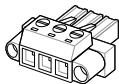

Power terminal block

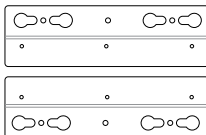

Wall mount kit with dampers



Remote power terminal block

## Optional item(s)\*

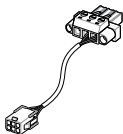

Terminal block power adapter

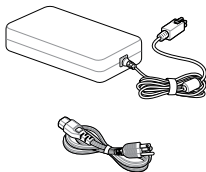

Power adapter and cord



Cellular network antenna



Wi-Fi antenna

---

### NOTE:

- \*These accessories are not bundled and need to be purchased separately.
  - Some bundled accessories may vary depending on the model. For details on these accessories, refer to their respective user manuals.
  - Illustrations of the device and accessories are for reference only. Actual product specifications may vary depending on the model.
  - If the device or its components fail or malfunction during normal and proper use within the warranty period, bring the warranty card to the ASUS Service Center for replacement of the defective components.
-

*1*

***Getting to know your  
Embedded Computer***

# 1.1 Features

## 1.1.1 Front view

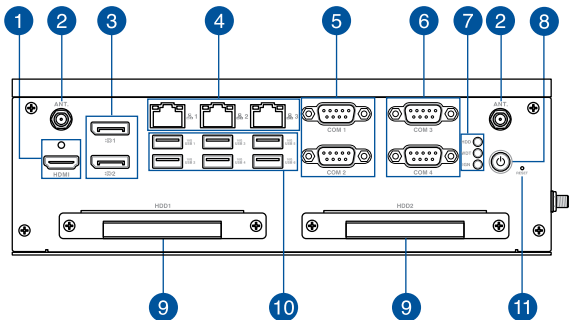

### 1 HDMI HDMI™ port with cable lock

The integrated HDMI (High Definition Multimedia Interface) port with a receptacle connector can support resolutions up to 4096 x 2160 @ 30 Hz on external display devices.

---

**NOTE:** The cable lock helps to prevent disconnection caused by tension or vibration.

---

## 2 ANT. **Wireless antenna jack**

The wireless antenna jack allows you to connect a wireless antenna.

---

**NOTE:** Wireless antennas are optional and may not come bundled.

---

## 3 **Dual-mode DisplayPort**



The DisplayPort 1.2 port can support resolutions up to 4096 x 2160 @ 60 Hz on external display devices.

## 4 **2.5G LAN port**





The 8-pin RJ-45 LAN port for 10/100/1000/2500 Mbps connection to a Local Area Network (LAN).

## LAN port LED indications

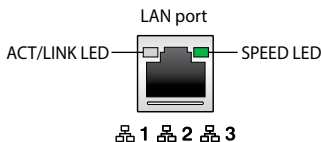

Activity Link LED	
Status	Description
Off	No link
Green	Linked
Green (blinking)	Data activity
Green (blinking then steady)	Ready to wake up from suspend mode

Speed LED	
Status	Description
Off	10/100 Mbps connection
Orange	1 Gbps connection
Green	2.5 Gbps connection

## 5 COM 1 Serial (COM) connector

### COM 2

The 9-pin DB9 connector allows you to connect RS-232/422/485 serial (COM) devices, such as bar code scanners, modems, and printers. Please refer to the table below for the pin definitions of the different COM connectors.

---

**NOTE:** Default set to RS-232. Setting can be changed through the BIOS.

---

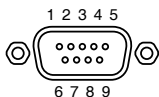

Pin	RS-232	RS-422	RS-485
1	DCD#	TX-	D-
2	RXD	TX+	D+
3	TXD	RX+	NA
4	DTR	RX-	NA
5	GND	GND	GND
6	DSR	NA	NA
7	RTS	NA	NA
8	CTS	NA	NA
9	RI	NA	NA

## 6 COM 3 Serial (COM) connector

COM 4

The 9-pin DB9 connector allows you to connect RS-232 serial (COM) devices, such as bar code scanners, modems, and printers. Please refer to the table below for the pin definitions of the different COM connectors.

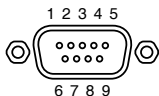

Pin	RS-232
1	DCD#
2	RXD
3	TXD
4	DTR
5	GND
6	DSR
7	RTS
8	CTS
9	RI

## 7 HDD Drive activity LED

The drive activity LED lights up when your Embedded Computer is accessing the internal storage drive.

## WDT Watchdog LED

The watchdog LED lights up when a watchdog time out event occurs.

## IGN Ignition LED

The ignition LED lights up when your Embedded Computer is powered on and in ignition mode.

---

**NOTE:** The default BIOS setting for the ignition function is disabled.

---

8



### **Power button**

The power button allows you to turn the Embedded Computer on or off. You can use the power button to put your Embedded Computer to sleep mode or press it for four (4) seconds to force shutdown your Embedded Computer.

9

### **HDD1 2.5-inch hot-swap storage bay**

**HDD2** The 2.5-inch hot-swap storage bay allows you to install a 2.5-inch HDD/SSD and supports RAID 0/1.

10

10G  
USB 1  
10G  
USB 2  
10G  
USB 3  
10G  
USB 4  
10G  
USB 5  
10G  
USB 6

### **USB 10Gbps port**

The USB (Universal Serial Bus) 10Gbps port provides a transfer rate up to 10 Gbit/s.

11

### **RESET System reset pinhole**

The hard reset pinhole allows you to reboot your Embedded Computer.

## 1.1.2 Rear view

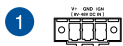
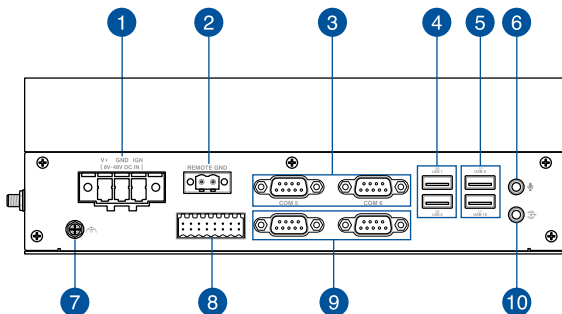

### Power input

The power input jack allows you to connect the bundled power terminal block.



### Remote power connector

The remote power connector allows you to connect an external power button or switch.

**3** **COM 5** **Serial (COM) connector**  
**COM 6**

The 9-pin DB9 connector allows you to connect RS-232 serial (COM) devices, such as bar code scanners, modems, and printers. Please refer to the table below for the pin definitions of the different COM connectors.

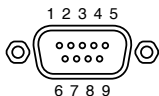

Pin	RS-232
1	DCD#
2	RXD
3	TXD
4	DTR
5	GND
6	DSR
7	RTS
8	CTS
9	RI

**4** **5G** **USB 7** **USB 5Gbps port**  
**5G** **USB 8**

The USB (Universal Serial Bus) 5Gbps port provides a transfer rate up to 5 Gbit/s.

**5** **2.0** **USB 9** **USB 2.0 port**  
**2.0** **USB 10**

The USB (Universal Serial Bus) port is compatible with USB 2.0 or USB 1.1 devices, such as keyboards, pointing devices, flash disk drives, external HDDs, speakers, cameras, and printers.

**6**  **Microphone input jack**

The microphone input jack is used to connect your Embedded Computer to an external microphone.

**7**  **Functional earth ground**

The functional earth ground provides you with a grounding point.

8

### Isolated DIO connector (optional)

The Isolated Digital Input/Output (DIO) connector provides electrical isolation of digital input and output signals, which allow micro controllers to detect and output logic states. The high voltage protection can be used in industrial level uses. Please refer to the illustration below for the specification and pin definitions of the Isolated DIO connector.

Signal	Specifications	
DO	Output voltage range	0~48 VDC
	Rated output current	4 A
DI	Voltage for logic "0"	0~3 VDC
	Voltage for logic "1"	10~48 VDC
	Rated input current	±50 mA

Pin	DIO	Pin	DIO
1	DI_COM	9	DI1
2	DI_COM	10	DI2
3	DIO_GND	11	DI3
4	DIO_GND	12	DI4
5	DIO_GND	13	DO1
6	DIO_GND	14	DO2
7	DO_PWR	15	DO3
8	DO_PWR	16	DO4

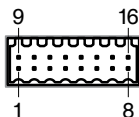

9

### Serial connector (optional)

The 9-pin DB9 connector allows you to connect additional serial devices.

10



### Audio output jack

This stereo audio jack is used to connect the system's audio out signal to amplified speakers.

### 1.1.3 Left view

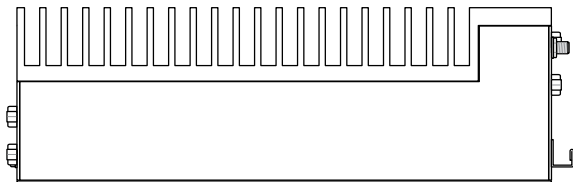

### 1.1.4 Right view

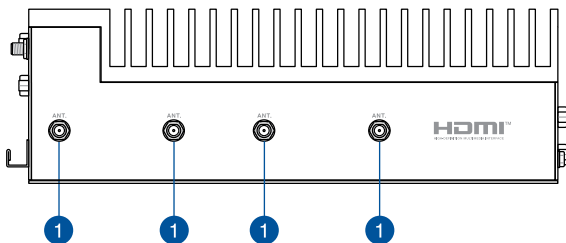

**1** **ANT. Wireless antenna jack**

The wireless antenna jack allows you to connect a wireless antenna.

---

**NOTE:** Wireless antennas are optional and may not come bundled.

---



<b>Jumpers</b>		<b>Page</b>
1.	COM +5V/+12V Selection jumper	21
2.	Clear RTC RAM jumper	22

<b>Connectors/slots</b>		<b>Page</b>
1.	Mini PCIe slot	23
2.	Battery connector	23
3.	M.2 M-key slot	24
4.	SATA 6Gb/s connector	25
5.	SPI TPM connector	26
6.	M.2 B-key slot	27
7.	Nano SIM Card slot	27
8.	M.2 E-key (Wi-Fi) slot	28
9.	COM Debug connector	28
10.	DC-in Power connector	29
11.	DIMM slot	30
12.	GPIO connector	30
13.	I2C connector	31

## 1.2.2 Onboard jumpers

### 1. COM +5V/+12V Selection jumper

The COM +5V/+12V Selection jumper allows you to select the voltage for the COM1 and COM2 ports.

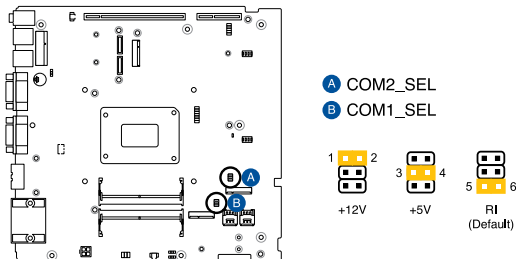

## 2. Clear RTC RAM jumper

The Clear RTC RAM jumper allows you to clear the Real Time Clock (RTC) RAM in the CMOS, which contains the date, time, system passwords, and system setup parameters.

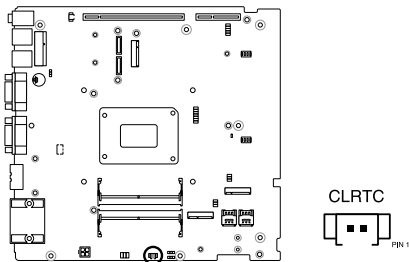

To erase the RTC RAM:

1. Turn OFF the computer and unplug the power cord.
2. Short-circuit pins 1-2 with a metal object or jumper cap for about 5-10 seconds.
3. Plug the power cord and turn ON the computer.
4. Hold down the <Delete> key during the boot process and enter BIOS setup to re-enter data.

---

**NOTE:** If the steps above do not help, disconnect the battery cable from the motherboard and short-circuit pins 1-2 again to clear the CMOS RTC RAM data. After clearing the CMOS, reconnect the battery cable.

---

## 1.2.3 Internal connectors

### 1. Mini PCIe slot

The Mini PCIe slot allows you to install a Mini PCIe peripheral device.

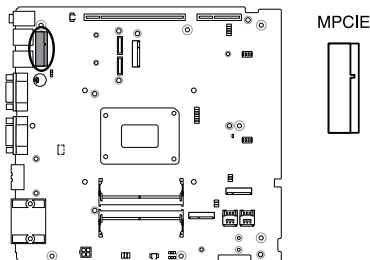

---

**NOTE:** The Mini PCIe peripheral device is purchased separately.

---

### 2. RTC Battery connector

The RTC Battery connector allows you to connect a lithium CMOS battery.

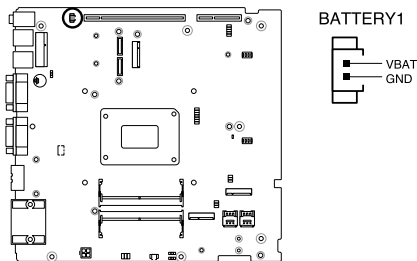

### 3. M.2 M-key slot

The M.2 M-key slot allows you to install an M-key (PCIe Gen4 x4), type 2280 M.2 device, such as an M.2 SSD module.

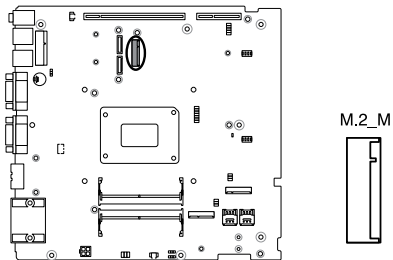

---

**NOTE:** The M.2 SSD module is purchased separately.

---

#### 4. SATA 6Gb/s connector

The SATA 6Gb/s allows you to connect SATA devices, such as optical disc drives and hard disk drives via a SATA cable.

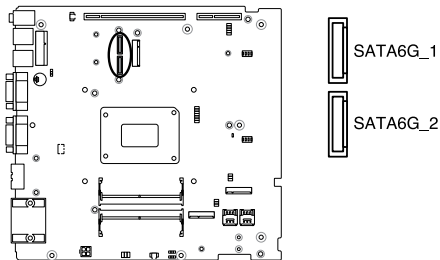

<b>Connector type</b>	Wafer HD 7p, 1.27mm pitch
-----------------------	---------------------------

---

**NOTE:** Ensure to use the bundled cable when connecting a storage device to this connector.

---

## 5. SPI TPM connector

The SPI TPM connector supports a Trusted Platform Module (TPM) system, which can securely store keys, digital certificates, passwords, and data. A TPM system also helps enhance network security, protects digital identities, and ensures platform integrity.

**NOTE:** The TPM module is purchased separately.

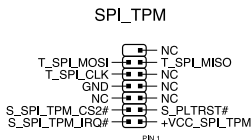
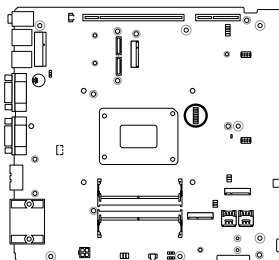

### Connector type

Header 2x7p, K14, 2.0mm pitch

## 6. M.2 B-key slot

The M.2 B-key slot allows you to install a B-key (PCIe x1, USB 3.2 Gen 1, USB 2.0) type 3042/3052 M.2 device, such as a 4G LTE or 5G NR module.

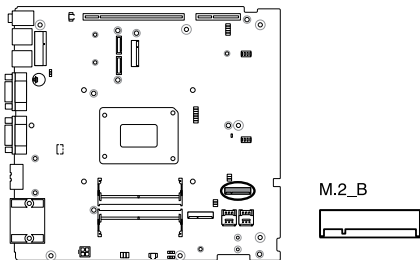

---

**NOTE:** The M.2 4G LTE or 5G NR module is purchased separately.

---

## 7. Nano SIM Card slot

The Nano SIM Card slot allows you to install a Nano SIM card.

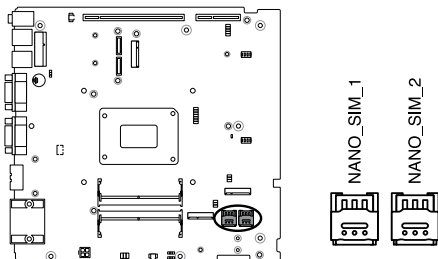

---

**NOTE:** Nano SIM cards are purchased separately.

---

## 8. M.2 E-key (Wi-Fi) slot

The M.2 E-key (Wi-Fi) slot allows you to install an E-key (PCIe, USB 2.0) type 2230 M.2 Wi-Fi module.

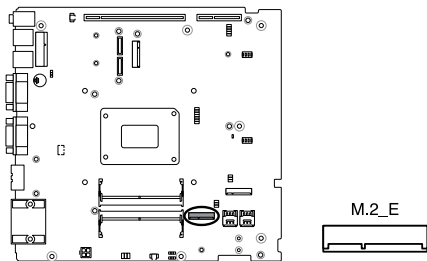

**NOTE:** The M.2 Wi-Fi module is purchased separately.

## 9. COM Debug connector

The COM Debug connector allows you to connect a COM debug card.

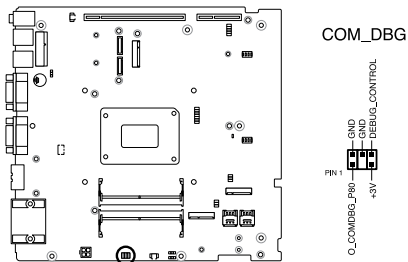

**Connector type**

Header 2x3p, 2.54mm pitch

## 10. DC-in 4-Pin Power connector

The DC-in 4-pin Power connector is for DC power input. Using a compatible power cable and power board, you may connect a suitable power supply with DC-in jacks.

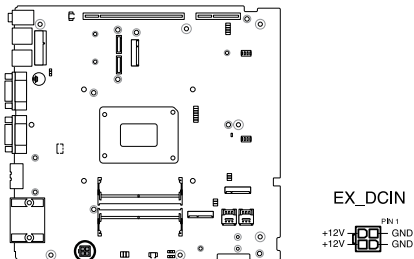

Connector type

POWER CON 4P W/P

**WARNING!** Only connect a single power connector (**EX\_DCIN** or **DCIN power input**) at a time, connecting both power connectors at the same time may cause damage to your Embedded Computer.

## 11. DIMM slot

The motherboard comes with a Small Outline Dual Inline Memory Module (SODIMM) slot designed for DDR5 (Double Data Rate 5) memory modules.

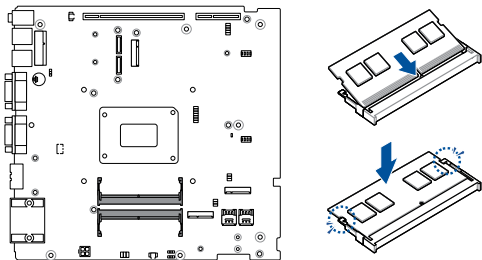

## 12. GPIO connector

The GPIO connector allows you to connect a general purpose input/output module to customize digital signal input/output.

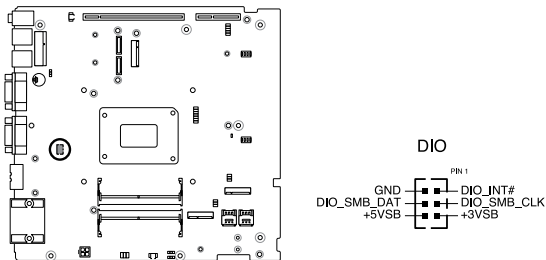

**Connector type**

BOX header 2x5p, K9, 2.0mm pitch

### 13. I2C connector

The I2C (Inter-Integrated Circuit) connector allows you to connect an I2C-compatible IoT security module.

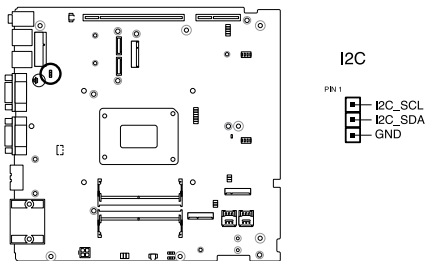

**Connector type**

Header 1x3p, K6, 2.0mm pitch



# 2

## ***Using your Embedded Computer***

## 2.1 Getting started

### 2.1.1 Connect the AC power adapter to your Embedded Computer

To connect the AC power adapter to your Embedded Computer:

- Connect the power cord to the AC power adapter.
- Connect the AC power adapter to the terminal block power adapter.
- Connect the 3-pin terminal block DC power connector into your Embedded Computer's power (DC) input.
- Plug the AC power adapter into a 100 V~240 V power source.

---

**NOTE:** The power adapter is purchased separately and may vary in appearance, depending on model and your region.

---

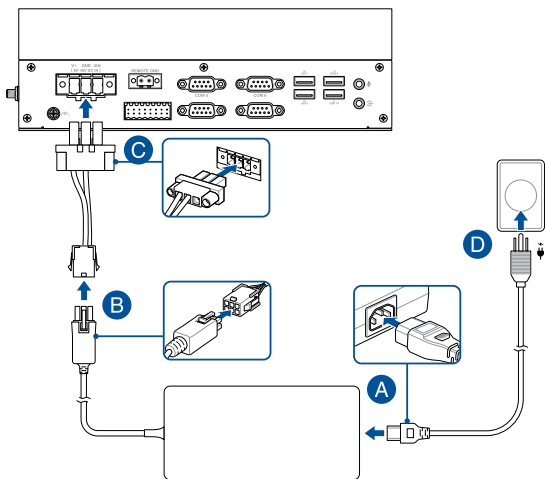

---

## IMPORTANT!

- We strongly recommend that you use only UL-certified power adapters and cables that meet the following requirements or ones that you purchased as an option with your Embedded Computer.

330 W Power adapter (operating temperature 0°C to 40°C)

Input voltage: 100-240 Vac

Input frequency: 50-60 Hz

Output current: 13.75 A (330 W)

Output voltage: 24 Vdc

System (operating temperature -25°C to 70°C)

Rated voltage: 8-48 Vdc

Rated current: 41.25 A - 6.875 A (330 W)

- We suggest using a power supply with 8 - 48 Vdc for DC-in that complies with the safety requirements of a regulated power source.
  - We strongly recommend that you use a grounded wall socket while using your Embedded Computer.
  - The socket outlet must be easily accessible and near your Embedded Computer.
  - To disconnect your Embedded Computer from its main power supply, unplug your Embedded Computer from the power socket.
- 

## WARNING!

- Do not use power adapters or batteries from other devices to reduce the risk of injury to persons due to fire or explosion. Use only UL certified power adapters or batteries supplied by the manufacturer or authorized retailers.
  - Do not disable or remove the power cord grounding plug, the grounding is an important safety feature.
  - Make sure to plug the power cord into a grounded (earthed) electrical outlet that is easily accessible at all times.
-

## 2.1.2 Connect a display panel to your Embedded Computer

You can connect a display panel or projector to your Embedded Computer that has the following connector(s):

- HDMI™ connector
- DisplayPort

### To connect a display panel to your Embedded Computer:

Connect one end of an HDMI™ or a DisplayPort cable to an external display, and the other end of the cable to your Embedded Computer's HDMI™ port or DisplayPort.

Connect display via HDMI™ port

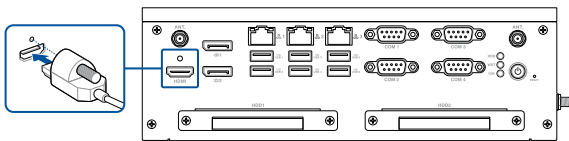

## Connect display via DisplayPort

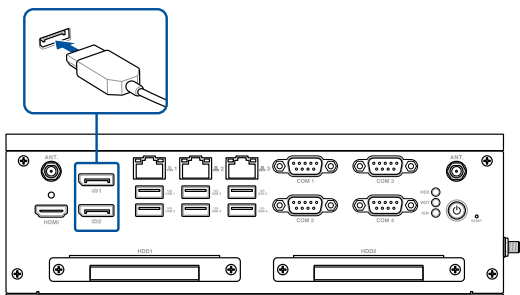

## 2.1.3 Connect the USB cable from keyboard or mouse

You can connect generally any USB keyboard and mouse to your Embedded Computer. You can also connect a USB dongle for a wireless keyboard and mouse set.

### To connect a keyboard and mouse to your Embedded Computer:

Connect the USB cable from your keyboard and mouse to any of the USB ports of your Embedded Computer.

---

#### NOTE:

- The keyboard varies with country and/or region.
  - The keyboard and mouse are purchased separately.
- 

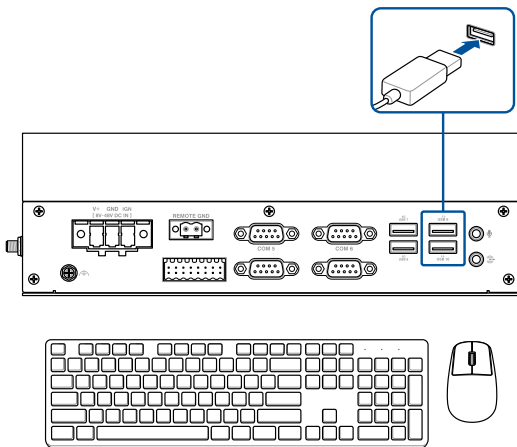

## 2.1.4 Turn on your Embedded Computer

Press the power button to turn on your Embedded Computer if it does not power on automatically when you connect it to a power source.

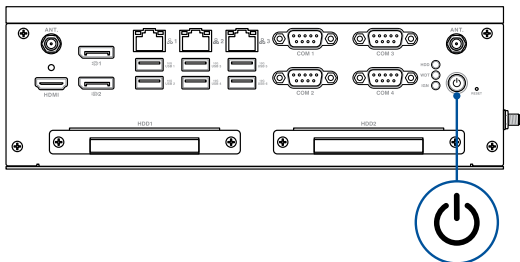

## 2.2 Turning off your Embedded Computer

If your Embedded Computer is unresponsive, press and hold the power button for at least four (4) seconds until your Embedded Computer turns off.

## 2.3 Installing wall mount brackets

1. Insert the eight (8) dampers bundled with the wall mount kit into the keyhole slots on the wall mount brackets and slide them into the narrower channel of each hole for secure placement.
2. Align the wall mount brackets to the screw holes on the bottom of your Embedded Computer, and then secure the wall mount brackets using the six (6) bundled screws.

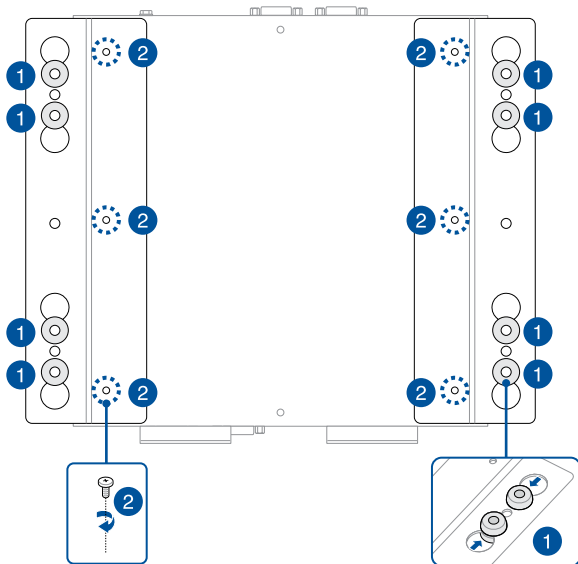



# 3

## ***Upgrading your Embedded Computer***

## 3.1 Installing a storage device

You may install up to two (2) 2.5-inch storage devices (hot-swappable, 7~7.5mm) to your Embedded Computer.

1. Loosen the two (2) screws securing each of the storage device trays to the right panel.
2. Pull the storage device tray out of the chassis.

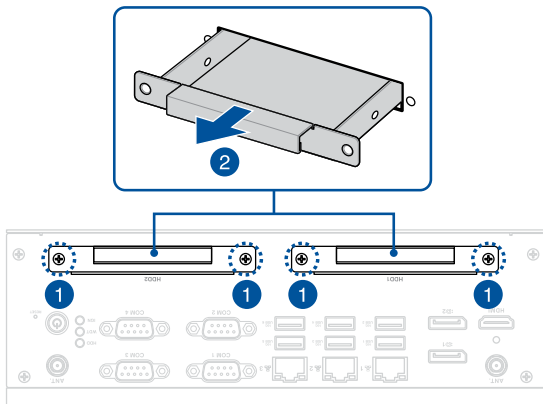

3. Install your storage device to the storage device tray (A), then secure it with four (4) screws (B).

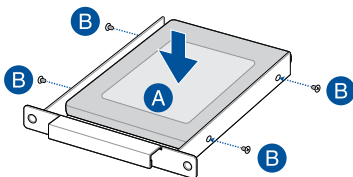

## 3.2 Removing the bottom cover

---

### **IMPORTANT!**

- Ensure that your hands are dry before proceeding with the rest of the installation process. Before installing any of the features in this guide, use a grounded wrist strap or touch a safely grounded object or metal object to avoid damaging them due to static electricity.
  - Turn off the power of your Embedded Computer and allow it to cool for at least 10 minutes before performing any installation/uninstallation process.
- 

**NOTE:** The illustrations in this section are for reference only. The slots may vary depending on model.

---

1. Turn off your Embedded Computer, and then disconnect all cables and peripherals.
2. Place the Embedded Computer on a flat stable surface with its top side facing down.
3. Remove the screws from the bottom cover, and then remove the bottom cover.

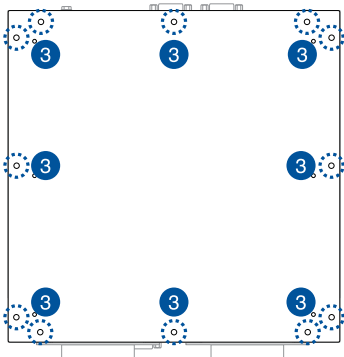

### 3.3 Replacing the bottom cover

Align the screw holes on the bottom cover with those on your Embedded Computer's chassis. Secure the bottom cover using the screws removed previously.

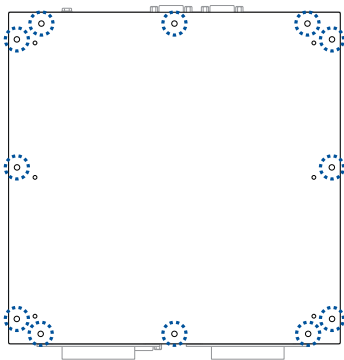

## 3.4 Removing the heat spreader

1. Follow the instructions in the **Removing the bottom cover** section to remove the bottom cover.
2. Follow steps 1-2 in the **Installing a storage device** section to remove the storage device trays.

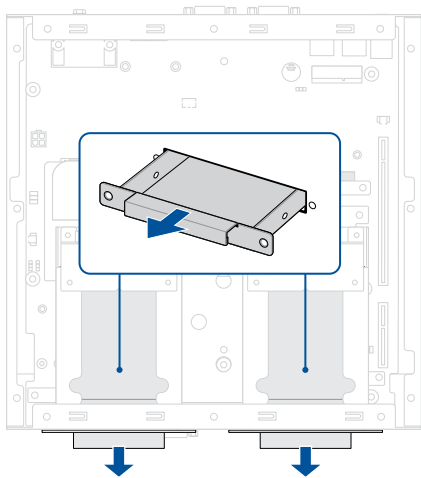

3. Remove the eight (8) screws securing the two (2) storage connector brackets, and set the brackets aside without disconnecting the SATA cables.

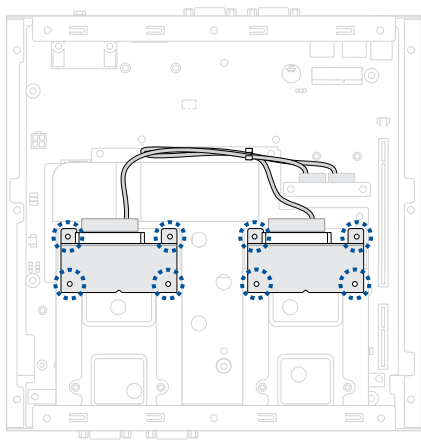

4. Remove the six (6) screws securing the heat spreader.

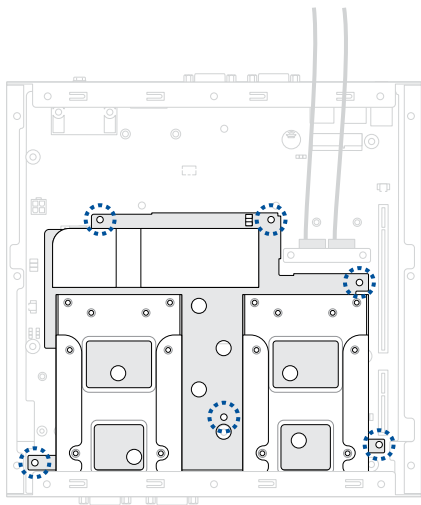

5. Carefully remove and set aside the heat spreader, making sure that the thermal pads on it do not come in contact with any surfaces.

## 3.5 Installing memory modules

Your Embedded Computer comes with two (2) SO-DIMM memory slots that allow you to install DDR5 SO-DIMMs, ECC\*, with a maximum of 64 GB.

### To install a memory module:

1. Follow the steps in the **Removing the heat spreader** section to remove the bottom cover and heat spreader.
2. Align and insert a memory module into one of the two SO-DIMM memory slots in the chassis.
3. Press down until the memory module is securely seated in place.

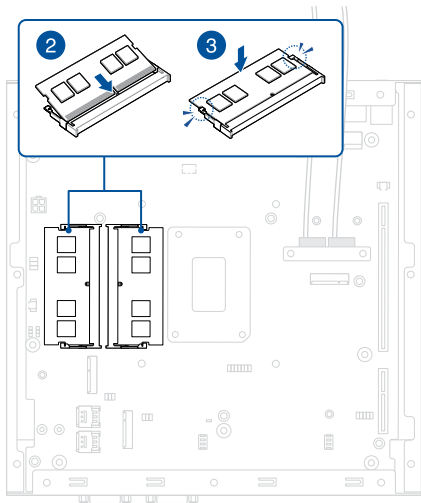

4. Repeat steps 2-3 to install the other memory module.

## 3.6 Installing an M.2 SSD module to the M.2 M-key slot

Your Embedded Computer comes with an M.2 M-key slot that allows you to install an M.2 (M-key, supports 2280 PCIe Gen4 x4) SSD module.

### To install an M.2 SSD module:

1. Follow the steps in the **Removing the heat spreader** section to remove the bottom cover and heat spreader.
2. Align and insert the M.2 SSD module into its slot inside the Embedded Computer.
3. Gently push down the module on top of the standoff and fasten it using a screw.

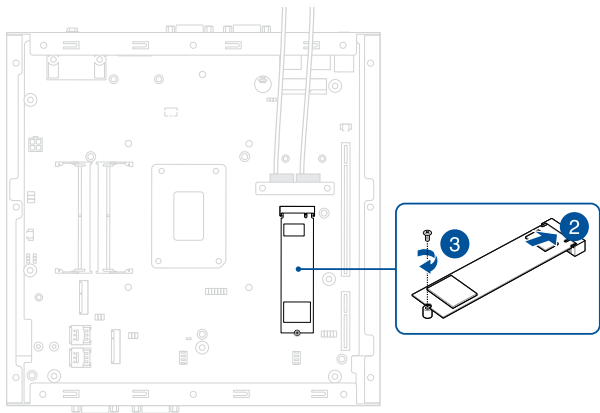

## 3.7 Installing a wireless card to the M.2 E-key slot

Your Embedded Computer comes with an M.2 E-key slot that allow you to install an M.2 (E-key, Wi-Fi / Bluetooth) wireless module.

---

**WARNING!** RF modules are intended for OEM or host integrators only. For availability of system level RF certification, check with your OEM integrator.

---

### To install an M.2 wireless module:

1. Follow the steps in the **Removing the heat spreader** section to remove the bottom cover and heat spreader.
2. Remove the screw from the M.2 standoff.
3. Align and insert the wireless card into its slot inside the Embedded Computer.
4. Gently push down the wireless card on top of the standoff, and then fasten it using the previously removed screw.
5. (Optional) Connect the RF cables from the antennas to your wireless card. Make sure that the correct cable is attached to each of the connectors by referring to the illustration below.

---

### NOTE:

- Please refer to the **Installing antennas** section for more information on installing the antennas.
  - Connecting antennas to your wireless card may strengthen the wireless signal.
  - A soft clicking sound indicates that the antenna has been securely attached on the wireless card.
-

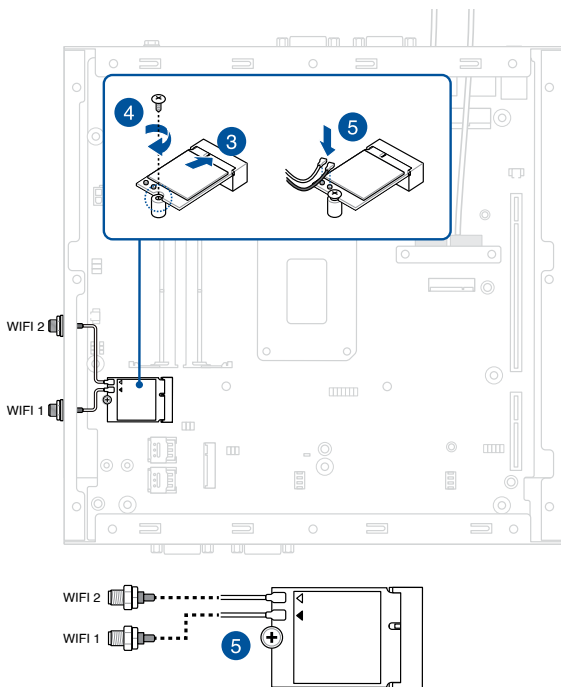

## 3.8 Installing a cellular network module to the M.2 B-key slot

Your Embedded Computer comes with an M.2 B-key slot that allows you to install a B-key (PCIe x1/USB 3.2 Gen 1/USB2.0, type 3042/3052) M.2 device, such as a 4G LTE or 5G NR module.

---

**WARNING!** RF modules are intended for OEM or host integrators only. For availability of system level RF certification, check with your OEM integrator.

---

### To install a 4G LTE module:

1. Follow the steps in the **Removing the heat spreader** section to remove the bottom cover and heat spreader.
2. Remove the screw from the M.2 standoff.
3. If the standoff is already seated in the right mounting hole to fit your module, skip to step 5.
4. Unscrew the standoff, and install it to a mounting hole that matches the length of your module.
5. Align and insert the module into the slot.
6. Press down, and then secure it in place using the screw previously removed.
7. (Optional) Connect the RF cables from the antennas to your module. Make sure that the correct cable is attached to each of the connectors by following chart on the next page.

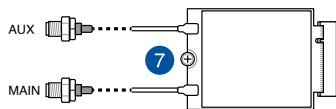
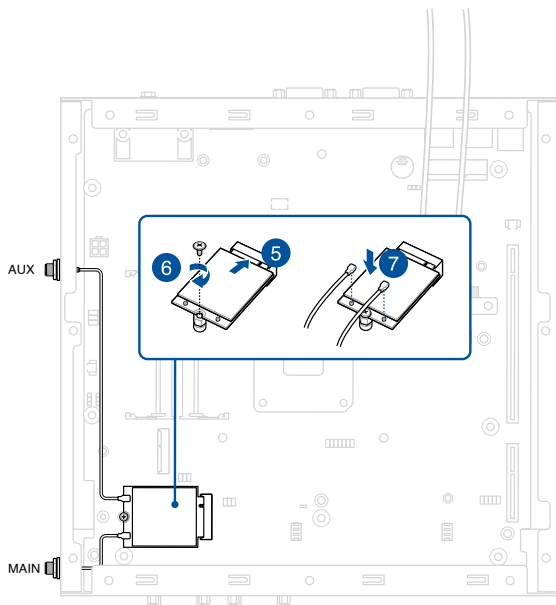

---

**NOTE:**

- Refer to **Installing antennas** for more information on installing the antennas.
  - Connecting antennas to your module may strengthen the signal.
  - A soft clicking sound indicates that the antenna has been securely attached on the module.
-

## To install a 5G NR module:

---

**WARNING!** RF modules are intended for OEM or host integrators only. For availability of system level RF certification, check with your OEM integrator.

---

1. Follow the steps in the **Removing the heat spreader** section to remove the bottom cover and heat spreader.
2. Remove the screw from the M.2 standoff.
3. If the standoff is already seated in the right mounting hole to fit your module, skip to step 5.
4. Unscrew the standoff, and install it to a mounting hole that matches the length of your module.
5. Align and insert the module into the slot.
6. Press down, and then secure it in place using the screw previously removed.
7. (Optional) Connect the RF cables from the antennas to your module. Make sure that the correct cable is attached to each of the connectors by following chart on the next page.

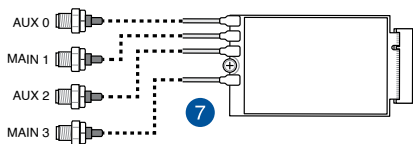
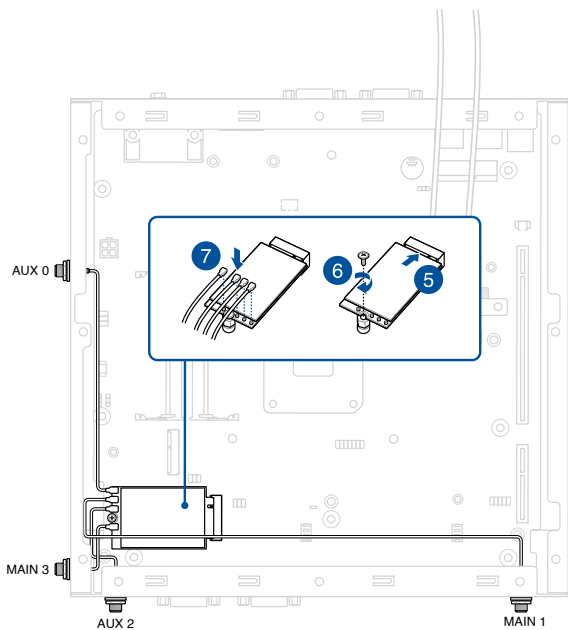

## 3.9 Installing an mPCIe module

Your Embedded Computer comes with an mPCIe slot that allows you to install an mPCIe add-on module, such as a CANbus module.

### To install an mPCIe module:

1. Follow the steps in the **Removing the heat spreader** section to remove the bottom cover and heat spreader.
2. Remove the two (2) screws from the standoffs.
3. Align and insert the module into the slot.
4. Press down, and then secure it in place using the two (2) screws previously removed.
5. Connect the necessary cables based on the type of module installed.

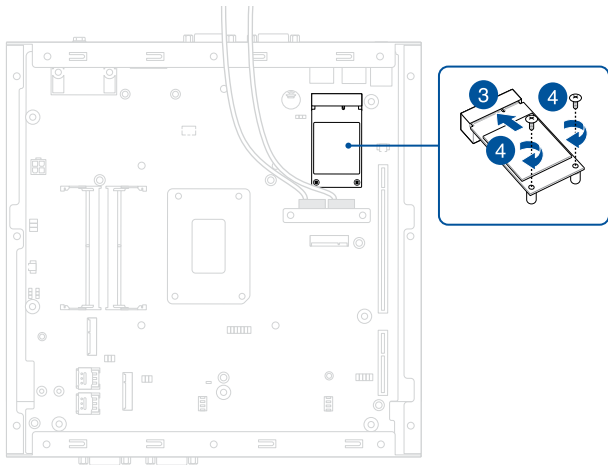

## 3.10 Installing a nano SIM card

Your Embedded Computer comes with two (2) nano SIM card slots.

---

**NOTE:** Nano SIM cards are purchased separately.

---

### To install a nano SIM card:

1. Follow the steps in the **Removing the heat spreader** section to remove the bottom cover and heat spreader.
2. (Optional) Remove the M.2 module from the M.2 B-key slot, if one is installed, by first removing the screw securing the module, and then removing the module.
3. Push the nano SIM cover in the direction towards the M.2 B-key slot.
4. Lift the nano SIM cover.
5. Place the nano SIM into the nano SIM slot.
6. Close the nano SIM cover.
7. Push the nano SIM cover away from the M.2 B-key slot to secure the nano SIM card.
8. Repeat steps 3 to 7 to install a second nano SIM card.

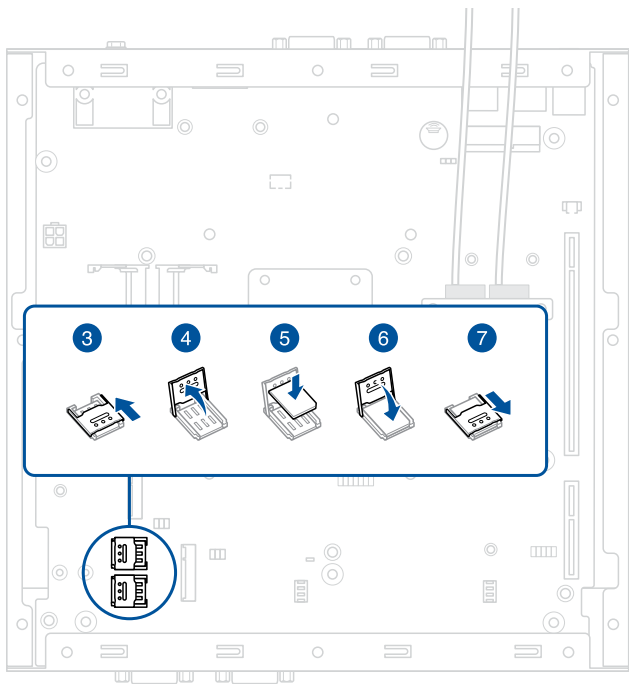

## 3.11 Installing antennas (optional)

You may install antennas to the six (6) antenna jacks located on the front and right sides of your Embedded Computer. The installed antennas can be connected to the 4G LTE or 5G NR module installed in the M.2 B-key slot and to the wireless card installed in the M.2 E-key Wi-Fi slot.

---

**NOTE:** It is recommended that you refer to the illustration that corresponds to the module(s) you have installed in your Embedded Computer.

---

### For 4G LTE module

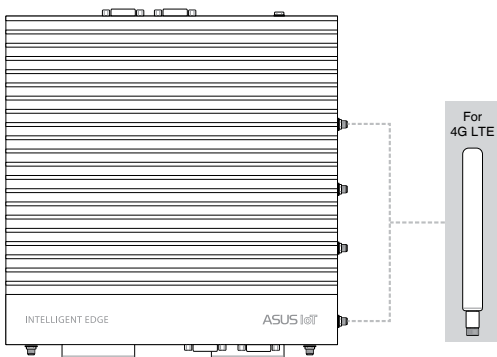

## For 5G NR module

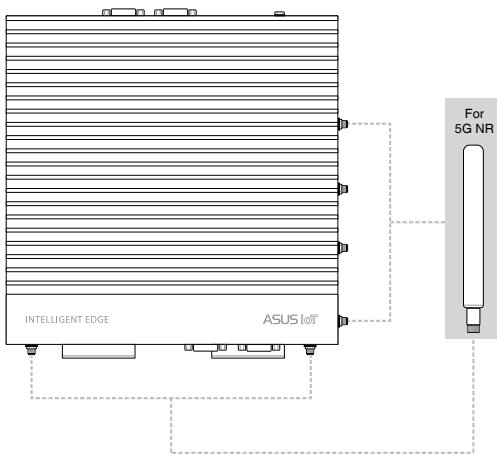

## For wireless card

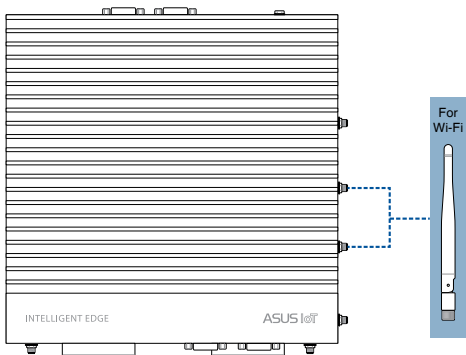



- (Optional) For RF cables that need to be connected to the front panel, route them to the 5G NR module through the two cutouts on the motherboard.

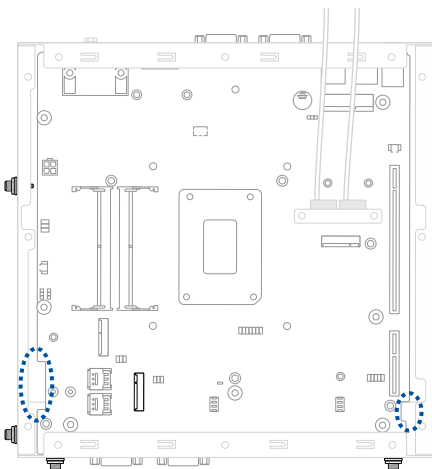

- Connect the other end of the RF connector and cable to your wireless card (refer to **Installing a wireless card to the M.2 E-key slot** for details) or to your cellular network module (refer to **Installing a cellular network module to the M.2 B-key slot** for details).
- Replace the bottom cover. Refer to **Replacing the bottom cover** for details.
- Screw the external wireless antennas onto their corresponding antenna jacks on your Embedded Computer by turning them in a clockwise direction.
- Position the antennas for optimal signal reception.

4

***Watchdog Timer***

## 4.1 Watchdog Timer implementation

The Watchdog Timer used in this Embedded Computer is the POST Watchdog Timer. The Watchdog Timer circuit is in SuperIO and can be controlled by the BIOS setup menu through the system BIOS for different boot phases.

Please refer to the table below for more details on the implementation of the Watchdog Timer.

Watchdog timer	Implementation	Default Timeout
POST Watchdog Timer	<p>This Watchdog Timer is for recovering the system from crashes during BIOS takeover to OS.</p> <hr/> <p><b>NOTE:</b> The default setting for the BIOS item is set to enabled.</p>	The timeout value is determined by the BIOS settings.
*OS Watchdog Timer	<p>No implementation. User needs to write software in OS to keep updating the watchdog timer to prevent it from timing out. The application is executed on payload.</p> <hr/> <p><b>NOTE:</b> Please refer to the section <b>Watchdog Timer Programming</b> for more information.</p>	N/A

## 4.2 Watchdog Timer programming

Please refer to the pseudo code for the NCT6116D watchdog timer programming below:

**SIO\_INDEX\_PORT is 0x2E**

**SIO\_DATA\_PORT is 0x2F**

### 1. Set WDT Time Unit

```
Outputb(SIO_INDEX_PORT, 0x87); // Unlock SIO
```

```
Outputb(SIO_INDEX_PORT, 0x87); // Unlock SIO
```

```
Outputb(SIO_INDEX_PORT, 0x07);
```

```
Outputb(SIO_DATA_PORT, 0x08);
```

```
Outputb(SIO_INDEX_PORT, 0xF0);
```

```
val = Inportb(SIO_DATA_PORT) // Read current WDT setting
```

```
val = val | 0x08; // minute mode, val = val & 0xF7 if second mode
```

```
Outputb(SIO_INDEX_PORT, 0xF0);
```

```
Outputb(SIO_DATA_PORT, val); // Write back WDT setting
```

```
Outputb(SIO_INDEX_PORT, 0xAA); // Lock SIO
```

## 2. Set WDT Time

```
Outputb(SIO_INDEX_PORT, 0x87); // Unlock SIO
Outputb(SIO_INDEX_PORT, 0x87); // Unlock SIO

Outputb(SIO_INDEX_PORT, 0x07);
Outputb(SIO_DATA_PORT, 0x08);
Outputb(SIO_INDEX_PORT, 0xF1);
Outputb(SIO_DATA_PORT, Time); // Write WDT time, value 1 to 255

Outputb(SIO_INDEX_PORT, 0xAA); // Lock SIO
```

## 3. Enable WDT

```
Outputb(SIO_INDEX_PORT, 0x87); // Unlock SIO
Outputb(SIO_INDEX_PORT, 0x87); // Unlock SIO

Outputb(SIO_INDEX_PORT, 0x07);
Outputb(SIO_DATA_PORT, 0x08);
Outputb(SIO_INDEX_PORT, 0x30);
val = Inportb(SIO_DATA_PORT) // Read current WDT status

val = val | 0x01; // Enable WDT Timer
Outputb(SIO_INDEX_PORT, 0x30);
Outputb(SIO_DATA_PORT, val); // Write back WDT status

Outputb(SIO_INDEX_PORT, 0xAA); // Lock SIO
```

#### 4. Disable WDT

```
Outportb(SIO_INDEX_PORT, 0x87); // Unlock SIO
Outportb(SIO_INDEX_PORT, 0x87); // Unlock SIO

Outportb(SIO_INDEX_PORT, 0x07);
Outportb(SIO_DATA_PORT, 0x08);
Outportb(SIO_INDEX_PORT, 0xF1);
Outportb(SIO_DATA_PORT, 0x00); // Clear WDT time, it means WDT
Time-Out disable

Outportb(SIO_INDEX_PORT, 0x30);

val = Inportb(SIO_DATA_PORT) // Read current WDT status
val = val & 0xFE; // Disable WDT Timer
Outportb(SIO_INDEX_PORT, 0x30);
Outportb(SIO_DATA_PORT, val); // Write back WDT status

Outportb(SIO_INDEX_PORT, 0xAA); // Lock SIO
```



# ***Appendix***

## Safety information

Your Embedded Computer is designed and tested to meet the latest standards of safety for information technology equipment. However, to ensure your safety, it is important that you read the following safety instructions.

### Setting up your system

- Read and follow all instructions in the documentation before you operate your system.
- Do not use this product near water or a heated source.
- Set up the system on a stable surface.
- Peripherals with extended tolerance (such as industrial grade memory and storage) will allow this product to be used in environments with ambient temperatures between  $-25^{\circ}\text{C}$  and  $70^{\circ}\text{C}$  with air flow.
- If you use an extension cord, make sure that the total ampere rating of the devices plugged into the extension cord does not exceed its ampere rating.
- This equipment should be installed and operated with a minimum distance of 20 cm between the radiator and your body.
- Restricted Access Area:  
The equipment should only be installed in a Restricted Access Area where both these conditions apply:
  - access can only be gained by skilled persons who have been instructed about the reasons for the restrictions applied to the area and about any precautions that shall be taken; and
  - access is through the use of a TOOL or lock and key, or other means of security, and is controlled by the authority responsible for the area.
- This device shall not be connected to an Ethernet network with outside plant routing.

## Care during use

- Do not walk on the power cord or allow anything to rest on it.
- Do not spill water or any other liquids on your system.
- When the system is turned off, a small amount of electrical current still flows. Always unplug the power cord from the power outlets before cleaning the system.
- Use this product with care when operating at full load, as the product, especially the outer casing, may reach elevated temperatures.
- If you encounter the following technical problems with the product, unplug the power cord and contact a qualified service technician or your retailer.
  - The power cord or plug is damaged.
  - Liquid has been spilled into the system.
  - The system does not function properly even if you follow the operating instructions.
  - The system was dropped or the cabinet is damaged.
  - The system performance changes.

## Lithium-Metal Battery Warning

**CAUTION!** Danger of explosion if battery is incorrectly replaced. Replace only with the same or equivalent type recommended by the manufacturer. Dispose of used batteries according to the manufacturer's instructions.

## NO DISASSEMBLY

**The warranty does not apply to the products that have been disassembled by users**



**DO NOT** throw the Embedded Computer in municipal waste. This product has been designed to enable proper reuse of parts and recycling. This symbol of the crossed out wheeled bin indicates that the product (electrical, electronic equipment, and mercury-containing button cell battery) should not be placed in municipal waste. Check local technical support services for product recycling.

# Regulatory notices

## FCC Compliance Information

Responsible Party: Asus Computer International

Address: 48720 Kato Rd., Fremont, CA 94538, USA

Phone / Fax No: (510)739-3777 / (510)608-4555

This device complies with Part 15 of the FCC Rules. Operation is subject to the following two conditions: (1) This device may not cause harmful interference, and (2) This device must accept any interference received including interference that may cause undesired operation.

This equipment has been tested and found to comply with the limits for a Class A digital device, pursuant to part 15 of the FCC Rules. These limits are designed to provide reasonable protection against harmful interference when the equipment is operated in a commercial environment.

This equipment generates, uses, and can radiate radio frequency energy and, if not installed and used in accordance with the instruction manual, may cause harmful interference to radio communications. Operation of this equipment in a residential area is likely to cause harmful interference in which case the user will be required to correct the interference at his own expense.

---

**IMPORTANT!** Outdoor operations in the 5.15~5.25 GHz band is prohibited. This device has no Ad-hoc capability for 5250~5350 and 5470~5725 MHz.

---

---

**CAUTION!** Any changes or modifications not expressly approved by the party responsible for compliance could void the user's authority to operate the equipment.

---

## Compliance Statement of Innovation, Science and Economic Development Canada (ISED)

This device complies with Innovation, Science and Economic Development Canada licence exempt RSS standard(s). Operation is subject to the following two conditions: (1) this device may not cause interference, and (2) this device must accept any interference, including interference that may cause undesired operation of the device.

CAN ICES-003(A)/NMB-003(A)

## Déclaration de conformité de Innovation, Sciences et Développement économique Canada (ISED)

Le présent appareil est conforme aux CNR d'Innovation, Sciences et Développement économique Canada applicables aux appareils radio exempts de licence. L'exploitation est autorisée aux deux conditions suivantes : (1) l'appareil ne doit pas produire de brouillage, et (2) l'utilisateur de l'appareil doit accepter tout brouillage radioélectrique subi, même si le brouillage est susceptible d'en compromettre le fonctionnement.

CAN ICES-003(A)/NMB-003(A)

## KC: Korea Warning Statement

Class A:

사용자 안내문

이 기기는 업무용 환경에서 사용할 목적으로 적합성평가를 받은 기기로서 가정용 환경에서 사용하는 경우 전파간섭의 우려가 있습니다.

## Safety Precautions

Accessories that came with this product have been designed and verified for the use in connection with this product. Never use accessories for other products to prevent the risk of electric shock or fire.

### 安全上のご注意

付属品は当該専用品です。他の機器には使用しないでください。機器の破損もしくは、火災や感電の原因となることがあります。

## Declaration of compliance for product environmental regulation

ASUS follows the green design concept to design and manufacture our products, and makes sure that each stage of the product life cycle of ASUS product is in line with global environmental regulations. In addition, ASUS disclose the relevant information based on regulation requirements.

Please refer to <https://esg.asus.com/Compliance.htm> for information disclosure based on regulation requirements ASUS is complied with.

### EU REACH and Article 33

Complying with the REACH (Registration, Evaluation, Authorization, and Restriction of Chemicals) regulatory framework, we publish the chemical substances in our products at ASUS REACH website at <https://esg.asus.com/Compliance.htm>

### EU RoHS

This product complies with the EU RoHS Directive. For more details, see <https://esg.asus.com/Compliance.htm>

### Japan JIS-C-0950 Material Declarations

Information on Japan RoHS (JIS-C-0950) chemical disclosures is available on <https://esg.asus.com/Compliance.htm>

### India RoHS

This product complies with the “India E-Waste (Management) Rules, 2016” and prohibits use of lead, mercury, hexavalent chromium, polybrominated biphenyls (PBBs) and polybrominated diphenyl ethers (PBDEs) in concentrations exceeding 0.1% by weight in homogenous materials and 0.01% by weight in homogenous materials for cadmium, except for the exemptions listed in Schedule II of the Rule.

### Vietnam RoHS

ASUS products sold in Vietnam, on or after September 23, 2011, meet the requirements of the Vietnam Circular 30/2011/TT-BCT.

Các sản phẩm ASUS bán tại Việt Nam, vào ngày 23 tháng 9 năm 2011 trở về sau, đều phải đáp ứng các yêu cầu của Thông tư 30/2011/TT-BCT của Việt Nam.

## **Türkiye RoHS**

AEEE Yönetmeliğine Uygundur

## **ASUS Recycling/Takeback Services**

ASUS recycling and takeback programs come from our commitment to the highest standards for protecting our environment. We believe in providing solutions for you to be able to responsibly recycle our products, batteries, other components as well as the packaging materials. Please go to <https://esg.asus.com/en/Takeback.htm> for detailed recycling information in different regions.

## **Ecodesign Directive**

The European Union announced a framework for the setting of ecodesign requirements for energy-related products (2009/125/EC). Specific implementing measures are aimed at improving environmental performance of specific products or across multiple product types. ASUS provides product information at <https://esg.asus.com/Compliance.htm>.

## 甲類警語

警告：為避免電磁干擾，本產品不應安裝或使用於住宅環境。

## China Compulsory Certification

警告：在居住環境中，運行此設備可能會造成無線電干擾。

「產品之限用物質含有情況」之相關資訊，請參考下表：

## Taiwan Declaration of Restricted Substances Marking

單元 (Unit)	限用物質及其化學符號 (Restricted substances and its chemical symbols)					
	鉛 Lead (Pb)	汞 Mercury (Hg)	鎘 Cadium (Cd)	六價鉻 Hexavalent chromium (Cr <sup>+6</sup> )	多溴聯苯 Polybrominated biphenyls (PBB)	多溴二苯醚 Polybrominated diphenyls ethers (PBDE)
印刷電路板 及電子組件 PCB	—	○	○	○	○	○
外殼 Chassis	—	○	○	○	○	○
硬碟 Disk drive	—	○	○	○	○	○
散熱設備 Thermal solutions	—	○	○	○	○	○
其他及其 配件 (線材等) Accessories (e.g., cables)	—	○	○	○	○	○

備考 1. “○” 係指該項限用物質之百分比含量未超出百分比含量基準值。

備考 2. “—” 係指該項限用物質為排除項目。

Note 1 “○” indicates that the percentage content of the restricted substance does not exceed the percentage of reference value of presence.

Note 2 The “—” indicates that the restricted substance corresponds to the exemption.

# UK: The Radio Equipment Regulations 2017 (S.I. 2017/1206)

## Simplified UKCA Declaration of Conformity

ASUSTek Computer Inc. hereby declares that this device is in compliance with the essential requirements and other relevant provisions of The Radio Equipment Regulations 2017 (S.I. 2017/1206). Full text of UKCA declaration of conformity is available at <https://www.asus.com/support/>.

The WiFi operating in the band 5150-5350MHz shall be restricted to indoor use for country listed below:

# UK

# EU: Radio Equipment Directive (Directive 2014/53/EU)

## Simplified EU Declaration of Conformity

ASUSTek Computer Inc. hereby declares that this device is in compliance with the essential requirements and other relevant provisions of Directive 2014/53/EU. Full text of EU declaration of conformity is available at <https://www.asus.com/support/>

The WiFi operating in the band 5150-5350MHz shall be restricted to indoor use for countries listed in the table below:

## Déclaration simplifiée de conformité de l'UE

ASUSTek Computer Inc. déclare par la présente que cet appareil est conforme aux critères essentiels et autres clauses pertinentes de la directive 2014/53/EU. La déclaration de conformité de l'UE peut être téléchargée à partir du site internet suivant :

<https://www.asus.com/support/>

Dans la plage de fréquence 5150-5350 MHz, le Wi-Fi est restreint à une utilisation en intérieur dans les pays listés dans le tableau ci-dessous:

## Vereinfachte EU-Konformitätserklärung

ASUSTek COMPUTER INC erklärt hiermit, dass dieses Gerät mit den grundlegenden Anforderungen und anderen relevanten Bestimmungen der Richtlinie 2014/53/EU übereinstimmt. Der gesamte Text der EU-Konformitätserklärung ist verfügbar unter: <https://www.asus.com/support/>

Der WLAN-Betrieb im Band von 5150-5350 MHz ist für die in der unteren Tabelle aufgeführten Länder auf den Innenbereich beschränkt:

## Dichiarazione di conformità UE semplificata

ASUSTek Computer Inc. con la presente dichiara che questo dispositivo è conforme ai requisiti essenziali e alle altre disposizioni pertinenti con la direttiva 2014/53/EU. Il testo completo della dichiarazione di conformità UE è disponibile all'indirizzo:

<https://www.asus.com/support/>

L'utilizzo della rete Wi-Fi con frequenza compresa nell'intervallo 5150-5350MHz deve essere limitato all'interno degli edifici per i paesi presenti nella seguente tabella:

## Упрощенное заявление о соответствии европейской директиве

ASUSTek Computer Inc. заявляет, что устройство соответствует основным требованиям и другим соответствующим условиям директивы 2014/53/EU. Полный текст декларации соответствия ЕС доступен на <https://www.asus.com/support/>

Работа WiFi в диапазоне частот 5150-5350 должна быть ограничена использованием в помещениях для стран, перечисленных в таблице ниже:

## إعلان التوافق المبسط الصادر عن الاتحاد الأوروبي

تقر شركة ASUSTek Computer أن هذا الجهاز يتوافق مع المتطلبات الأساسية والأحكام الأخرى ذات الصلة الخاصة بتوجيه 2014/53/EU. يتوفر النص الكامل لإعلان التوافق الصادر عن الاتحاد الأوروبي على:

<https://www.asus.com/support/>

يجب حصر استخدام WiFi العاملة بـ 5150-5350 ميجا هرتز على الاستخدام المنزلي للبلدان المدرجة بالجدول.

## Опростена декларация за съответствие на ЕС

С настоящото ASUSTek Computer Inc. декларира, че това устройство е в съответствие със съществените изисквания и другите приложими постановления на свързаната Директива 2014/53/ЕС. Пълният текст на ЕС декларация за съвместимост е достъпен на адрес <https://www.asus.com/support/>

WiFi, работеща в диапазон 5150-5350MHz, трябва да се ограничи до употреба на закрито за страните, посочени в таблицата по-долу:

## Declaração de Conformidade UE Simplificada

ASUSTek Computer Inc. declara que este dispositivo está em conformidade com os requisitos essenciais e outras disposições relevantes relacionadas às diretivas 2014/53/UE. O texto completo da declaração de conformidade CE está disponível em <https://www.asus.com/support/>

O WiFi operando na banda 5150-5350MHz deve ser restrito para uso interno para os países listados na tabela abaixo:

## Pojednostavljena EU Izjava o sukladnosti

ASUSTek Computer Inc. ovim izjavljuje da je ovaj uređaj sukladan s bitnim zahtjevima i ostalim odgovarajućim odredbama direktive 2014/53/EU. Cijeli tekst EU izjave o sukladnosti dostupan je na <https://www.asus.com/support/>

WiFi koji radi na opsegu frekvencija 5150-5350 MHz bit će ograničen na upotrebu u zatvorenom prostoru u zemljama na donjem popisu:

## Zjednodušené prohlášení o shodě EU

Společnost ASUSTek Computer Inc. tímto prohlašuje, že toto zařízení splňuje základní požadavky a další příslušná ustanovení směrnice 2014/53/EU. Plné znění prohlášení o shodě EU je k dispozici na adrese <https://www.asus.com/support/>

V zemích uvedených v tabulce je provoz sítě Wi-Fi ve frekvenčním rozsahu 5 150 - 5 350 MHz povolen pouze ve vnitřních prostorech:

## Forenklet EU-overensstemmelseerklæring

ASUSTEK Computer Inc. erklærer hermed at denne enhed er i overensstemmelse med hovedkravene og øvrige relevante bestemmelser i direktivet 2014/53/EU. Hele EU-overensstemmelseerklæringen kan findes på <https://www.asus.com/support/>

Wi-Fi, der bruger 5150-5350 MHz skal begrænses til indendørs brug i lande, der er anført i tabellen:

## Vereenvoudigd EU-conformiteitsverklaring

ASUSTEK Computer Inc. verklaart hierbij dat dit apparaat voldoet aan de essentiële vereisten en andere relevante bepalingen van Richtlijn 2014/53/EU. De volledige tekst van de EU-conformiteitsverklaring is beschikbaar op <https://www.asus.com/support/>

De WiFi op 5150-5350MHz zal beperkt zijn tot binnengebruik voor in de tabel vermelde landen:

## Lihtsustatud EÜ vastavusdeklaratsioon

Käesolevaga kinnitab ASUSTEK Computer Inc, et seade vastab direktiivi 2014/53/EÜ olulistele nõuetele ja teistele asjakohastele sätetele. EÜ vastavusdeklaratsiooni täistekst on saadaval veebisaidil <https://www.asus.com/support/>

Sagedusvahemikus 5150-5350 MHz töötava WiFi kasutamine on järgmistes riikides lubatud ainult siseruumides:

## Eurooppa - EY:n vaatimustenmukaisuusvakuutus

ASUSTek Computer Inc. ilmoittaa täten, että tämä laite on direktiivin 2014/53/EU olennaisien vaatimusten ja muiden asiaankuuluvien lisäysten mukainen. Koko EY:n vaatimustenmukaisuusvakuutuksen teksti on luettavissa osoitteessa <https://www.asus.com/support/>

5 150 - 5 350 MHzzin taajuudella toimiva WiFi on rajoitettu sisäkäyttöön taulukossa luetelluissa maissa:

## تبعیت از نسخه ساده شده بیانیه اتحادیه اروپا

ASUSTek Computer Inc در اینجا اعلام می کند که این دستگاه با نیازهای اساسی و سایر مقررات مربوط به بیانیه 2014/53/UE، مطابقت دارد. متن کامل پیروی از این بیانیه اتحادیه اروپا در این آدرس موجود است: <https://www.asus.com/support/>

عملکرد 5150-5350 مگاهرتز برای WiFi باید برای استفاده در فضای داخل ساختمان برای کشورهای فهرست شده در جدول، محدود شود.

## Απλοποιημένη Δήλωση Συμμόρφωσης ΕΕ

Διά του παρόντος η ASUSTek Computer Inc. δηλώνει ότι αυτή η συσκευή είναι σύμμορφη με τις βασικές προϋποθέσεις και άλλες σχετικές διατάξεις της Οδηγίας 2014/53/ΕΕ. Το πλήρες κείμενο της δήλωσης συμμόρφωσης της ΕΕ είναι διαθέσιμο στη διεύθυνση <https://www.asus.com/support/>

To WiFi που λειτουργεί στη ζώνη 5150-5350MHz περιορίζεται για χρήση σε εσωτερικούς χώρους για τις χώρες που αναφέρονται στον παρακάτω πίνακα:

## הצהרת תאימות רגולטורית מקוצרת עבור האיחוד אירופי

ASUSTek Computer Inc. מצהירה בזאת כי מכשיר זה תואם לדרישות החיוביות ולשאר הסעיפים הרלוונטיים של תקנה 2014/53/EU. ניתן לקרוא את הנוסח המלא של הצהרת התאימות הרגולטורית עבור האיחוד האירופי בכתובת: <https://www.asus.com/support/>

יש להגביל רשתות Wi-Fi הפועלות ברצועת התדרים 5150-5350MHz לשימוש בתוך מבנים סגורים בארצות המפורסות ברשימה הבאה:

### Egyszerűsített EU megfelelési nyilatkozat

Az ASUSTek Computer Inc. ezennel kijelenti, hogy ez az eszköz megfelel az 2014/53/EU sz. irányelv alapvető követelményeinek és egyéb vonatkozó rendelkezéseinek. Az EU megfelelési nyilatkozat teljes szövegét a következő weboldalon tekintheti meg: <https://www.asus.com/support/>

Az 5150-5350 MHz-es sávban működő Wi-Fi-t beltéri használatra kell korlátozni az alábbi táblázatban felsorolt országokban:

### Pernyataan Kesesuaian UE yang Disederhanakan

ASUSTek Computer Inc. dengan ini menyatakan bahwa perangkat ini memenuhi persyaratan utama dan ketentuan relevan lainnya yang terdapat pada Petunjuk 2014/53/EU. Teks lengkap pernyataan kesesuaian EU tersedia di: <https://www.asus.com/support/>

WiFi yang Beroperasi pada 5150-5350 MHz akan terbatas untuk penggunaan dalam ruangan di negara yang tercantum dalam tabel

### Vienkāršota ES atbilstības paziņojums

ASUSTek Computer Inc. ar šo paziņo, ka šī ierīce atbilst Direktīvas 2014/53/ES būtiskajām prasībām un citiem citiem saistošajiem nosacījumiem. Pilns ES atbilstības paziņojuma teksts pieejams šeit: <https://www.asus.com/support/>

Wi-Fi darbība 5150–5350 MHz ir jāierobežo lietošanai telpās valstīs, kuras norādītas tālāk.

### Supaprastinta EU atitikties deklaracija

Šiame dokumente bendrovė „ASUSTek Computer Inc.“ pareiškia, kad šis prietaisas atitinka pagrindinius reikalavimus ir kitas susijusias Direktyvos 2014/53/ES nuostatas. Visas EU atitikties deklaracijos tekstas pateikiamas čia: <https://www.asus.com/support/>

Toliau nurodytose šalyse „WiFi“ ryšiu, veikiančiu 5 150–5 350 MHz dažnio juostoje, galima naudotis tik patalpose:

### Forenklet EU-samsvarserklæring

ASUSTek Computer Inc. erklærer herved at denne enheten er i samsvar med hovedsaklige krav og andre relevante forskrifter i direktivet 2014/53/EU. Fullstendig tekst for EU-samsvarserklæringen finnes på: <https://www.asus.com/support/>

Wi-Fi-området 5150–5350 MHz skal begrenses til innendørs bruk for landene som er oppført i tabellen:

### Uproszczone deklaracja zgodności UE

Firma ASUSTek Computer Inc. niniejszym oświadczam, że urządzenie to jest zgodne z zasadniczymi wymogami i innymi właściwymi postanowieniami dyrektywy 2014/53/EU. Pełny tekst deklaracji zgodności UE jest dostępny pod adresem <https://www.asus.com/support/>

W krajach wymienionych w tabeli działanie sieci Wi-Fi w paśmie 5150–5350 MHz powinno być ograniczone wyłącznie do pomieszczeń:

### Declaração de Conformidade Simplificada da UE

A ASUSTek Computer Inc. declara que este dispositivo está em conformidade com os requisitos essenciais e outras disposições relevantes da Diretiva 2014/53/UE. O texto integral da declaração de conformidade da UE está disponível em <https://www.asus.com/support/>

A utilização das frequências WiFi de 5150 a 5350MHz está restrita a ambientes interiores nos países apresentados na tabela:

### Declarație de conformitate UE, versiune simplificată

Prin prezenta, ASUSTek Computer Inc. declară că acest dispozitiv este în conformitate cu reglementările esențiale și cu celelalte prevederi relevante ale Directivei 2014/53/UE. Textul complet al declarației de conformitate UE este disponibil la adresa <https://www.asus.com/support/>

Pentru țările listate în tabelul de mai jos, rețelele WiFi care funcționează în banda de frecvență de 5.150-5.350 MHz trebuie utilizate doar în interior:

### Pojednostavljena Deklaracija o usaglašenosti EU

ASUSTek Computer Inc. ovim izjavljuje da je ovaj uređaj usaglašen sa osnovnim zahtevima i drugim relevantnim odredbama Direktive 2014/53/EU. Ceo tekst Deklaracije o usaglašenosti EU dostupan je na lokaciji <https://www.asus.com/support/>

WiFi koji radi u frekventnom opsegu od 5150 MHz do 5350 MHz ograničen je isključivo na upotrebu u zatvorenom prostoru za zemlje navedene u tabeli ispod:

## **Зjednodušené vyhlásenie o zhode platné pre EÚ**

Spoločnosť ASUSTek Computer Inc. týmto vyhlasuje, že toto zariadenie je v súlade so základnými požiadavkami a ďalšími príslušnými ustanoveniami smernice č. 2014/53/EÚ. Plné znenie vyhlásenia o zhode pre EÚ je k dispozícii na lokalite <https://www.asus.com/support/>

Činnosť WiFi v pásme 5150 - 5350 MHz bude obmedzená na použitie vo vnútornom prostredí pre krajiny uvedené v tabuľke nižšie:

### **nostavljena izjava EU o skladnosti**

ASUSTek Computer Inc. tukaj izjavlja, da je ta naprava skladna s temeljnimi zahtevami in drugimi relevantnimi določili Direktive 2014/53/EU. Polno besedilo izjave EU o skladnosti je na voljo na <https://www.asus.com/support/>

WiFi, ki deluje v pasovnem območju 5150–5350 MHz, mora biti v državah, navedenih v spodnjem seznamu, omejen na notranjo uporabo:

### **Declaración de conformidad simplificada para la UE**

Por la presente, ASUSTek Computer Inc. declara que este dispositivo cumple los requisitos básicos y otras disposiciones pertinentes de la directiva 2014/53/EU. En <https://www.asus.com/support/> está disponible el texto completo de la declaración de conformidad para la UE.

La conexión WiFi con una frecuencia de funcionamiento de 5150-5350 MHz se restringirá al uso en interiores para los países enumerados en la tabla:

### **Förenklad EU-försäkran om överensstämmelse**

ASUSTek Computer Inc. deklarerar härmed att denna enhet överensstämmer med de grundläggande kraven och andra relevanta bestämmelser i direktiv 2014/53/EU. Fullständig text av EU-försäkran om överensstämmelse finns på <https://www.asus.com/support/>

WiFi som använder 5150-5350 MHz kommer att begränsas för användning inomhus i de länder som anges i tabellen:

### **ประกาศเกี่ยวกับความสอดคล้องของสหภาพยุโรปแบบย่อ**

ASUSTek Computer Inc. ขอประกาศในที่นี้ว่าอุปกรณ์นี้มีความสอดคล้องกับ ความ

ต้องการที่จำเป็นและเงื่อนไขที่เกี่ยวข้องอื่น ๆ ของบทบัญญัติข้อกำหนด 2014/53/EU เนื้อหาที่สมบูรณ์ของประกาศความ

สอดคล้องกับ EU มีอยู่ที่ <https://www.asus.com/support/>

การทำงานของ WiFi ที่ 5150-5350MHz ถูกจำกัดให้ใช้ในอาคารสำหรับประเทศที่แสดงในตาราง

### **Basitleştirilmiş AB Uyumluluk Bildirimi**

ASUSTek Computer Inc., bu aygıtın 2014/53/EU Yönergesinin temel gereksinimlerine ve diğer ilgili hükümlerine uygun olduğunu bildirir. AB uyumluluk bildiriminin tam metni şu adreste bulunabilir: <https://www.asus.com/support/>

5150-5350 MHz arasındaki WiFi çalışması, tabloda listelenen ülkeler için iç mekân kullanımıyla kısıtlanacaktır.

### **Спрощена декларація про відповідність нормам ЄС**

ASUSTek Computer Inc. заявляє, що цей пристрій відповідає основним вимогам та іншим відповідним вимогам

Директиви 2014 / 53 / EU. Повний текст декларації відповідності нормам ЄС доступний на

<https://www.asus.com/support/>

Робота Wi-Fi на частоті 5150-5350 МГц обмежується використанням у приміщенні для країн, поданих у таблиці нижче:

### **Жеңілдетілген ЕО талаптарына сәйкестік бойынша мәлімдеме**

ASUSTek Computer Inc. компаниясы осымен бұл құрылғының 2014/53/EU директивасының маңызды

талаптары мен басқа тиісті қағидаларына сәйкес келетіндігін жариялайды. ЕО талаптарына сәйкестік

бойынша мәлімдеменің толық мәтіні мына мекенжай бойынша қолжетімді: <https://www.asus.com/support/>.

Төмендегі кестеде келтірілген елдер үшін 5150-5350 МГц жиіліктер диапазонында жұмыс істейтін Wi-Fi

желілерін тек бөлме ішінде пайдалануға рұқсат берілуі керек:

AT	BE	BG	CZ	DK	EE	FR
DE	IS	IE	IT	EL	ES	CY
LV	LI	LT	LU	HU	MT	NL
NO	PL	PT	RO	SI	SK	TR
FI	SE	CH	HR	UK (NI)		



## RF Module Warning Statement

RF modules are intended for OEM or host integrators only. For availability of system level RF certification, check with your OEM integrator.

## HDMI Trademark Notice

The terms HDMI, HDMI High-Definition Multimedia Interface, HDMI trade dress and the HDMI Logos are trademarks or registered trademarks of HDMI Licensing Administrator, Inc.

## Service and Support

Visit our multi-language website at <https://www.asus.com/support/>.

