



**GP-6600S GP-4600S GP-2600S
GP-566S GP-546S GP-526S
Online Manual**

Contents

Symbols Used in This Document.	19
Trademarks and Licenses.	20
Trademarks.	21
Licenses.	22
Basic Operations.	48
Printer Parts.	49
Front.	50
Ink Tank Cover (Inside).	53
Back / Side.	55
Top Cover (Inside).	56
Carriage.	58
Operation Panel.	59
Printer Stand.	61
Roll Unit.	63
Using the Printer.	65
Turning the Printer On and Off.	66
Loading Rolls in the Printer.	69
Loading Sheets in the Printer.	76
Using the Basket on the Printer Stand.	82
Example Basket Configurations.	87
Storing the Basket on the Printer Stand.	91
Using the Roll Unit for Media Take-Up.	93
Switching Roll Unit Modes.	94
Using the Roll Unit In Take-Up Mode.	97
Removing Printed Paper from the Roll Unit.	107
Stopping Printing.	110
Pausing Printing.	111
Printing.	112
Printing from Computer (macOS).	114
Printing with Easy Setup.	115
Setting the Number of Copies and Printing Order.	118

Using Roll Unit to Use 2-Level Rolls.	120
About 2-Level Roll Switching.	121
Setting the Paper Rolls in the Printer According to the Intended Use.	122
Printing by Automatically Switching Upper-level and Lower-level Roll Papers.	124
How to Switch Paper Rolls.	127
Reflect Roll Unit Settings in the Printer Driver.	132
Changing the Print Quality and Correcting Image Data.	133
Adjusting Color Balance.	134
Setting the Print Quality Level (Custom).	136
Printing a Color Document in Monochrome.	137
Specifying Color Correction.	138
Optimal Photo Printing of Image Data.	140
Adjusting Colors with the Printer Driver.	141
Printing with ICC Profiles (Specifying an ICC Profile from the Application Software).	143
Printing with ICC Profiles (Specifying an ICC Profile from the Printer Driver).	145
Adjusting Brightness.	147
Adjusting Contrast.	148
Scaled Printing.	149
Printing to Oversized Paper Sizes.	151
Setting Paper Dimensions (Custom Size).	153
Set a Custom Size Roll Width.	154
Printing without Edges Based on the Scenarios.	155
Printing without Margins to Match Roll Paper Width.	156
Printing Full-Size without Margins.	158
Three-sided Borderless Printing on Roll Paper.	160
Printing Hanging and Horizontal Banners (Large-Format Printing).	164
Printing by Dividing/Joining Documents.	165
Lining Up and Printing Multiple Documents.	166
Printing by Connecting Multiple Pages.	167
Printing Multiple Pages All on One Page.	168
Printing Document in Center of Paper.	170
Printing by Saving Roll Paper.	172
Saving Roll Paper by Rotating Document 90 Degrees.	173
Saving Roll Paper by Eliminating Upper and Lower Margins on Document.	174
Switching the Paper Source to Match the Purpose.	175

Cutting Roll Paper after Printing.	176
Printing Using AirPrint.	177
Printing from Printer.	180
Printing Data Saved on USB Flash Drive.	181
Printing from Smartphone/Tablet.	184
Printing from iOS Device (AirPrint).	185
Enlarging Copy with imageRUNNER ADVANCE.	189
Fitting to Paper Width.	194
Specifying Magnification Level.	195
Managing Print Jobs.	199
Handling Print Jobs.	200
Deleting Print Jobs.	201
Priority Printing.	203
Printing Pending Jobs.	205
Printing Security Print Jobs.	207
Using the Printer Hard Disk to Handle Print Jobs.	209
Using Printer Hard Disk.	210
Saving Print Jobs in Personal Job Boxes.	212
Printing Saved Jobs.	213
Deleting Saved Jobs.	215
Moving Saved Jobs.	217
Saving Print Jobs Sent from Sources Other than Printer Driver.	218
Printing without Saving Jobs in Common Job Box.	220
Setting Passwords for Personal Job Boxes.	221
Naming Personal Job Boxes.	222
Printing List of Saved Jobs.	223
Renaming Saved Jobs.	224
Printer Hard Disk Operations.	225
Checking Free Hard Disk Space.	226
macOS Printer Driver.	227
Overview of the Printer Driver.	228
Canon IJ Printer Driver.	229
Checking Layout in Preview before Printing.	230
Registering a Changed Printing Profile.	231

How to Open the Printer Driver Setup Dialog.	232
Page Setup Dialog.	233
Print Dialog.	234
Updating Media Information in Printer Driver.	236
Correcting Media Information in Printer Driver (When Printer Used in Shared Environment).	238
Confirm the Printer Paper Information.	239
Setting Accounting Information.	240
Set a PIN Code for Print Jobs.	241
Deleting the Undesired Print Job.	242
Displaying the Printing Status Screen.	243
Canon IJ Printer Utility2.	244
Opening the Canon IJ Printer Utility2.	245
Checking the Ink Status from Your Computer.	246
Instructions for Use (Printer Driver).	247
Description of Print Dialog.	248
Quality & Media.	249
Color Options.	251
Advanced Paper Settings.	253
Page Processing.	255
Additional Settings.	257
Updating the Printer Driver.	258
Obtaining the Latest Printer Driver.	259
Delete the Unnecessary Canon IJ Printer from the Printer List.	260
Before Installing the Printer Driver.	261
Installing the Printer Driver.	262
Handling Paper.	263
Handling rolls.	265
Loading Rolls on the Roll Holder.	266
Loading Rolls in the Printer.	69
Loading Roll Paper in the Roll Unit.	276
Removing the Roll from the Printer.	283
Removing Roll Paper from the Roll Unit.	286
Removing Rolls From the Roll Holder.	289
Feeding Roll Paper Manually.	291
Cutting Roll Paper.	292
Cutting Roll Paper after Printing.	293

Automatically Switch Rolls.	297
Handling sheets.	298
Loading Sheets in the Printer.	76
Removing Sheets.	305
Printing From a Desired Starting Point.	307
Paper Settings.	311
Changing the Type of Paper.	312
Specifying the Paper Length.	314
Keeping Track of the Amount of Roll Paper Left.	315
Specifying the Cutting Method for Rolls.	318
Cutting the Leading Edge of Roll Paper Automatically.	321
Reducing Dust from Cutting Rolls.	323
Specifying the Ink Drying Time.	325
Specifying the Amount of Extension for Borderless Printing.	329
Information about Paper.	332
Paper Sizes.	333
Updating paper information.	335
Using Paper Other Than Genuine Paper and feed confirmed Paper.	336
Printing on Paper Other Than Genuine Paper and feed confirmed Paper Using Existing Settings.	337
Printing on Paper Other Than Genuine Paper and feed confirmed Paper by Adding a Media Type.	338
Settings.	339
Changing Settings from Operation Panel.	341
Home Screen Menu Composition.	342
Menu Structure.	347
Advanced (Paper settings).	368
Advanced (LAN settings).	370
Setting Items on Operation Panel.	373
Maintenance.	375
Job management.	377
LAN settings.	378
Test print.	386
Print settings.	387
Web service setup.	389

Paper-related settings.	390
Auto maintenance settings.	394
Hard disk settings.	395
Monitoring service settings.	397
Other printer settings.	399
Language selection.	401
Firmware update.	402
Security settings.	403
Printer information.	404
Setting Administrator Password on Operation Panel.	405
Erasing Data on Printer's Hard Disk.	407
Status Print.	408
Changing Printer's Setting Using Web Browser.	410
Start up Remote UI.	411
Changeable Setting Items Using Remote UI.	414
Security.	416
LAN settings.	417
Setting Passwords Using Remote UI.	419
Registering Printer's Root Certificate to Web Browser for SSL Communication.	421
Registering Printer's Root Certificate to Local Computer for SSL Communication.	425
Generating Server Certificate.	431
Setting Mail Server.	433
Receiving Printer Status by E-mail.	435
Migrating Printer's Setting.	437
Initializing Printer's Setting.	439
Network Setting.	440
Printer Connection Methods.	441
Wi-Fi Connection.	443
WPS Connection.	446
WPS (PIN Code) Connection.	449
Manual connect.	452
Easy wireless connect.	457
Wireless Direct Connection.	459
Wired Connection.	463
USB Connection.	467

Another Printer Found with Same Name.	468
Printing Network Settings.	469
Countermeasures against Unauthorized Access.	470
Network Status and Troubleshooting.	472
Sharing the Printer on a Network (macOS).	474
Settings on Print Server.	475
Settings on Client PC.	476
Restrictions on Printer Sharing.	477
Maintenance.	478
Adjustments for Better Print Quality.	480
Checking for Nozzle Clogging.	481
Cleaning the Print Head.	483
Adjustment to Straighten Lines and Align Colors.	485
Automatic Adjustment to Straighten Lines and Align Colors.	486
Manual Adjustment to Straighten Lines and Align Colors.	488
Adjusting Different Colored Horizontal Streaks.	490
Automatically Adjusting Different Colored Horizontal Streaks.	491
Manually Adjusting Different Colored Horizontal Streaks.	493
Fine-Tuning Paper Feed Amount.	495
Adjusting Line Length.	496
Troubleshooting Paper Abrasion and Blurry Images.	498
Changing the Print Head Height.	499
Adjusting Vacuum Strength.	501
Color Management.	502
Managing Colors.	503
Performing Color Calibration.	505
Adjustment Types of Color Calibration.	508
Replacing Consumables.	511
Checking the Ink Tank Model Number.	512
Replacing Ink Tanks.	514
Checking Ink Level.	529
Replacing the Print Head.	531
Replacing the Maintenance Cartridge.	539
Checking the Remaining Maintenance Cartridge Capacity.	544
Replacing the Cutter Blade.	545

Cleaning the Printer.	549
Cleaning the Printer Exterior.	550
Cleaning Inside the Top Cover.	552
Cleaning the Roll Unit.	555
Cleaning the Internal Light.	557
Performing Maintenance Functions from Your Computer (macOS).	559
Opening Remote UI for Maintenance.	560
Cleaning the Print Heads.	561
Printing a Nozzle Check Pattern.	564
Other Maintenance.	565
Preparing to Transfer the Printer.	566
Reinstalling the Printer.	571
Firmware update.	574
Frequently Asked Questions.	575
The printer does not respond even if print jobs are sent.	579
Printing stops and an error message is displayed.	580
Failed to Printer Driver Installation (Windows).	581
Removing Printer Software.	582
Problems with the Printing Quality.	584
Printing is faint.	585
Banding in different colors occurs.	587
Colors in printed images are uneven.	590
Image edges are blurred or white banding occurs.	593
Paper rubs against the Print Head.	595
The edges of the paper are dirty.	597
The surface of the paper is dirty.	600
The back side of the paper is dirty.	602
Immediately after borderless printing, the trailing edge margin is soiled during regular printing.	605
Printed colors are inaccurate.	606
Documents are printed in monochrome.	608
Line thickness is not uniform.	609
Lines or colors are misaligned.	611
The length of the printed image in the paper ejection direction is not accurate.	613
Images are printed crooked.	615
Margins are wide.	616

Borders appear in borderless printing.	617
When printing on roll paper, the printed surface becomes scratched.	618
Cannot Configure Network Settings.	619
Cannot Proceed beyond Printer Connection Screen/Connect Cable Screen.	620
"Failed to connect to the wireless router." Appears.	622
Taking Time to Setup Process (Windows).	624
Cannot Find Printer on Network.	625
Cannot Connect Printer to Network.	626
Cannot Find Printer During Setup.	627
Cannot Find Printer while Using Wi-Fi.	632
Cannot Find Printer while Using Wired LAN.	635
Searching Printer by IP Address or Host Name During Setup.	636
Cannot Print over Network.	639
Cannot Print over TCP/IP Network.	640
Cannot Print over Bonjour networks.	641
Cannot Print Using AirPrint.	642
Network Connection Problems.	643
Network Settings and Common Problems.	644
Cannot Connect to the Printer.	645
Printer Problems.	650
Printer Does Not Turn On.	651
Messages advising to check the maintenance cartridge are not cleared.	652
The Data lamp on the Operation Panel does not light up.	653
If the Printer Makes a Strange Sound.	654
Printed pages are not collected cleanly in the basket.	656
Basket Lurches.	657
Warning Message is Displayed When Performing Color Calibration.	658
Paper is not Fed or Ejected Properly.	659
Remove Jammed Roll Paper.	660
Remove a Jammed Sheet.	665
Roll paper cannot be inserted into the Paper Feed Slot.	669
Cannot load sheets.	670
Roll Paper Is not Fed Automatically.	671
Roll Paper Is not Switched Automatically.	673

Paper Source Does Not Switch When Roll Paper Is Used Up.	674
Roll Paper Remains/Lacks under Quantity Management.	675
The printer ejects blank, unprinted paper.	676
Paper Cutting Problems.	677
Paper is not cut.	678
Paper is not cut straight.	679
Cutter Blade Does Not Work While Cutting Is in Progress.	681
I want to know how to configure roll cutting.	682
I want to configure so that the roll is cut automatically after waiting for the ink to dry.	683
When Trim edge first is set, the trimmed paper is drawn into the roll unit.	684
Paper Setting Problems.	685
Paper widths with high transparency cannot be detected.	686
I want to know the paper types that can be used in this printer.	687
Estimated paper type does not match the loaded paper type.	688
The paper type that I want to print is not displayed on the Touch Screen.	689
Ink-related Problems.	690
Printer consumes a lot of ink.	691
Ink Level Detection.	692
Does this printer support sub-ink tank system.	693
About Print Settings.	694
How do I print without borders.	695
I want to easily create vertical or horizontal banners.	696
Can I perform duplex printing.	697
I want to perform enlargement printing.	698
List of Support Code for Error.	699
1005.	702
100A.	703
100B.	704
100E.	705
100F.	706
1012.	707
1018.	708
1019.	709

1021.....	710
1022.....	711
1023.....	712
1024.....	713
1025.....	714
1034.....	715
1035.....	716
1036.....	717
1039.....	718
1040.....	719
1051.....	720
1052.....	721
1054.....	722
1056.....	723
1057.....	724
1058.....	725
1059.....	726
1061.....	727
1200.....	728
1201.....	729
1210.....	730
1213.....	731
1214.....	732
1300.....	733
1306.....	734
1317.....	735
1318.....	736
1322.....	737
1323.....	738
1324.....	739
1325.....	740
1326.....	741
1327.....	742

1328.	743
1329.	744
1401.	745
1403.	746
1408.	747
1409.	748
140A.	749
140B.	750
140C.	751
140F.	752
1468.	753
1477.	754
1478.	755
1480.	756
1481.	757
1485.	758
1492.	759
1494.	760
1495.	761
1500.	762
1551.	763
1552.	764
1570.	765
1571.	766
1660.	767
168B.	768
1720.	769
1721.	770
1722.	771
1730.	772
1731.	773
1752.	774
1753.	775

1756.....	776
1757.....	777
1875.....	778
2001.....	779
2002.....	780
2130.....	781
2131.....	782
2132.....	783
3000.....	784
3001.....	785
3006.....	786
3101.....	787
3200.....	788
3201.....	789
3250.....	790
3306.....	791
3311.....	792
3312.....	793
3313.....	794
3314.....	795
3315.....	796
3316.....	797
3317.....	798
3331.....	799
3332.....	800
3333.....	801
3334.....	802
3335.....	803
3336.....	804
3338.....	805
3341.....	806
3350.....	807
3351.....	808

3352.....	809
3414.....	810
3415.....	811
3416.....	812
3417.....	813
3418.....	814
3419.....	815
3420.....	816
3421.....	817
3422.....	818
3423.....	819
3424.....	820
3448.....	821
3451.....	822
4107.....	823
4111.....	824
4112.....	825
4113.....	826
4114.....	827
4116.....	828
4117.....	829
4119.....	830
4120.....	831
4121.....	832
4122.....	833
4801.....	834
4803.....	835
4804.....	836
4805.....	837
4806.....	838
4808.....	839
4900.....	840
4901.....	841

4903.	842
4905.	843
4909.	844
4910.	845
4911.	846
4913.	847
4920.	848
4922.	850
4924.	851
4925.	852
4926.	853
4927.	854
4931.	855
4932.	856
4933.	857
4934.	858
4935.	859
4950.	860
4952.	861
4953.	862
4954.	863
4955.	864
4956.	865
5200.	866
5A60.	867
5B10.	868
5B16.	869
5B20.	870
5B21.	871
5C00.	872
6502.	873
6700.	874
6702.	875

6820.....	876
6900.....	877
6901.....	878
6902.....	879
6910.....	880
6920.....	881
6921.....	882
6930.....	883
6931.....	884
6932.....	885
6933.....	886
6940.....	887
6941.....	888
6942.....	889
6943.....	890
6944.....	891
6945.....	892
6946.....	893
7050.....	894
7051.....	895
7052.....	896
8200.....	897
9000.....	898
9110.....	899
B20A.....	900
B510.....	901
Printer Information.....	902
Safety.....	903
Safety Precautions.....	904
Regulatory Information.....	907
WEEE.....	909
Handling Precautions.....	923

When Repairing, Lending, or Disposing of the Printer.	924
Specifications.	925
Specifications.	926
Print Area.	932
Appendix.	934
Online Manual.	935

Symbols Used in This Document

Warning

Instructions that, if ignored, could result in death, serious personal injury, or property damage caused by incorrect operation of the equipment. These must be observed for safe operation.

Caution

Instructions that, if ignored, could result in personal injury or property damage caused by incorrect operation of the equipment. These must be observed for safe operation.

Important

Instructions including important information that must be observed to avoid damage and injury or improper use of the product. Be sure to read these instructions.

Note

Instructions including notes for operation and additional explanations.

Basics

Instructions explaining basic operations of your product.

Note

- Icons may vary depending on your product.

Trademarks and Licenses

- ▶ Trademarks
- ▶ Licenses

Trademarks

- Microsoft is a registered trademark of Microsoft Corporation.
- Windows is a trademark or registered trademark of Microsoft Corporation in the U.S. and/or other countries.
- Windows Vista is a trademark or registered trademark of Microsoft Corporation in the U.S. and/or other countries.
- Microsoft Edge and Excel are either trademarks or registered trademarks of Microsoft Corporation in the U.S. and/or other countries.
- Internet Explorer is a trademark or registered trademark of Microsoft Corporation in the U.S. and/or other countries.
- Mac, Mac OS, macOS, OS X, AirPort, App Store, AirPrint, the AirPrint logo, Safari, Bonjour, iPad, iPad Air, iPad mini, iPadOS, iPhone and iPod touch are trademarks of Apple Inc., registered in the U.S. and other countries.
- IOS is a trademark or registered trademark of Cisco in the U.S. and other countries and is used under license.
- Google Cloud Print, Google Chrome, Chrome OS, Chromebook, Android, Google Drive, Google Apps and Google Analytics are either registered trademarks or trademarks of Google Inc. Google Play and Google Play Logo are trademarks of Google LLC.
- Adobe, Acrobat, Flash, Photoshop, Illustrator, Adobe RGB and Adobe RGB (1998) are either registered trademarks or trademarks of Adobe Systems Incorporated in the United States and/or other countries.
- Adobe, Acrobat, Flash, Photoshop, Photoshop Elements, Lightroom, Adobe RGB and Adobe RGB (1998) are either registered trademarks or trademarks of Adobe Systems Incorporated in the United States and/or other countries.
- Google, Google Home, and Android are trademarks of Google LLC.
- App Store is a trademark of Apple Inc., registered in the U.S. and other countries.
- Bluetooth is a trademark of Bluetooth SIG, Inc., U.S.A. and licensed to Canon Inc.
- AOSS™ is a trademark of BUFFALO INC.
- Autodesk and AutoCAD are registered trademarks or trademarks of Autodesk, Inc., and/or its subsidiaries and/or affiliates in the USA and/or other countries.
- QR Code is a registered trademark of DENSO WAVE INCORPORATED in Japan and in other countries.
- The Mopria® word mark and the Mopria® Logo are registered and/or unregistered trademarks of Mopria Alliance, Inc. in the United States and other countries. Unauthorized use is strictly prohibited.
- HP-GL and HP-GL/2 are either registered trademarks or trademarks of HP Inc. in the United States and/or other countries.
- Mozilla Firefox is a trademark or registered trademark of Mozilla Foundation in the U.S. and/or other countries.
- Wi-Fi, WPA, WPA2 and WPA3 are either registered trademarks or trademarks of Wi-Fi Alliance.
- All other company names and products mentioned in this guide may be registered trademarks or trademarks of their respective companies.

»» Note

- The formal name of Windows Vista is Microsoft Windows Vista operating system.

Licenses

Copyright (c) 2003-2015 Apple Inc. All rights reserved.

Redistribution and use in source and binary forms, with or without modification, are permitted provided that the following conditions are met:

1. Redistributions of source code must retain the above copyright notice, this list of conditions and the following disclaimer.
2. Redistributions in binary form must reproduce the above copyright notice, this list of conditions and the following disclaimer in the documentation and/or other materials provided with the distribution.
3. Neither the name of Apple Inc. ("Apple") nor the names of its contributors may be used to endorse or promote products derived from this software without specific prior written permission.

THIS SOFTWARE IS PROVIDED BY APPLE AND ITS CONTRIBUTORS "AS IS" AND ANY EXPRESS OR IMPLIED WARRANTIES, INCLUDING, BUT NOT LIMITED TO, THE IMPLIED WARRANTIES OF MERCHANTABILITY AND FITNESS FOR A PARTICULAR PURPOSE ARE DISCLAIMED. IN NO EVENT SHALL APPLE OR ITS CONTRIBUTORS BE LIABLE FOR ANY DIRECT, INDIRECT, INCIDENTAL, SPECIAL, EXEMPLARY, OR CONSEQUENTIAL DAMAGES (INCLUDING, BUT NOT LIMITED TO, PROCUREMENT OF SUBSTITUTE GOODS OR SERVICES; LOSS OF USE, DATA, OR PROFITS; OR BUSINESS INTERRUPTION) HOWEVER CAUSED AND ON ANY THEORY OF LIABILITY, WHETHER IN CONTRACT, STRICT LIABILITY, OR TORT (INCLUDING NEGLIGENCE OR OTHERWISE) ARISING IN ANY WAY OUT OF THE USE OF THIS SOFTWARE, EVEN IF ADVISED OF THE POSSIBILITY OF SUCH DAMAGE.

Apache License

Version 2.0, January 2004

<http://www.apache.org/licenses/>

TERMS AND CONDITIONS FOR USE, REPRODUCTION, AND DISTRIBUTION

1. Definitions.

"License" shall mean the terms and conditions for use, reproduction, and distribution as defined by Sections 1 through 9 of this document.

"Licensor" shall mean the copyright owner or entity authorized by the copyright owner that is granting the License.

"Legal Entity" shall mean the union of the acting entity and all other entities that control, are controlled by, or are under common control with that entity. For the purposes of this definition, "control" means (i) the power, direct or indirect, to cause the direction or management of such entity, whether by contract or otherwise, or (ii) ownership of fifty percent (50%) or more of the outstanding shares, or (iii) beneficial ownership of such entity.

"You" (or "Your") shall mean an individual or Legal Entity exercising permissions granted by this License.

"Source" form shall mean the preferred form for making modifications, including but not limited to software source code, documentation source, and configuration files.

"Object" form shall mean any form resulting from mechanical transformation or translation of a Source form, including but not limited to compiled object code, generated documentation, and conversions to other media types.

"Work" shall mean the work of authorship, whether in Source or Object form, made available under the License, as indicated by a copyright notice that is included in or attached to the work (an example is provided in the Appendix below).

"Derivative Works" shall mean any work, whether in Source or Object form, that is based on (or derived from) the Work and for which the editorial revisions, annotations, elaborations, or other modifications represent, as a whole, an original work of authorship. For the purposes of this License, Derivative Works shall not include works that remain separable from, or merely link (or bind by name) to the interfaces of, the Work and Derivative Works thereof.

"Contribution" shall mean any work of authorship, including the original version of the Work and any modifications or additions to that Work or Derivative Works thereof, that is intentionally submitted to Licensor for inclusion in the Work by the copyright owner or by an individual or Legal Entity authorized to submit on behalf of the copyright owner. For the purposes of this definition, "submitted" means any form of electronic, verbal, or written communication sent to the Licensor or its representatives, including but not limited to communication on electronic mailing lists, source code control systems, and issue tracking systems that are managed by, or on behalf of, the Licensor for the purpose of discussing and improving the Work, but excluding communication that is conspicuously marked or otherwise designated in writing by the copyright owner as "Not a Contribution."

"Contributor" shall mean Licensor and any individual or Legal Entity on behalf of whom a Contribution has been received by Licensor and subsequently incorporated within the Work.

2. Grant of Copyright License. Subject to the terms and conditions of this License, each Contributor hereby grants to You a perpetual, worldwide, non-exclusive, no-charge, royalty-free, irrevocable copyright license to reproduce, prepare Derivative Works of, publicly display, publicly perform, sublicense, and distribute the Work and such Derivative Works in Source or Object form.
3. Grant of Patent License. Subject to the terms and conditions of this License, each Contributor hereby grants to You a perpetual, worldwide, non-exclusive, no-charge, royalty-free, irrevocable (except as stated in this section) patent license to make, have made, use, offer to sell, sell, import, and otherwise transfer the Work, where such license applies only to those patent claims licensable by such Contributor that are necessarily infringed by their Contribution(s) alone or by combination of their Contribution(s) with the Work to which such Contribution(s) was submitted. If You institute patent litigation against any entity (including a cross-claim or counterclaim in a lawsuit) alleging that the Work or a Contribution incorporated within the Work constitutes direct or contributory patent infringement, then any patent licenses granted to You under this License for that Work shall terminate as of the date such litigation is filed.
4. Redistribution. You may reproduce and distribute copies of the Work or Derivative Works thereof in any medium, with or without modifications, and in Source or Object form, provided that You meet the following conditions:
 1. You must give any other recipients of the Work or Derivative Works a copy of this License; and
 2. You must cause any modified files to carry prominent notices stating that You changed the files; and

3. You must retain, in the Source form of any Derivative Works that You distribute, all copyright, patent, trademark, and attribution notices from the Source form of the Work, excluding those notices that do not pertain to any part of the Derivative Works; and
4. If the Work includes a "NOTICE" text file as part of its distribution, then any Derivative Works that You distribute must include a readable copy of the attribution notices contained within such NOTICE file, excluding those notices that do not pertain to any part of the Derivative Works, in at least one of the following places: within a NOTICE text file distributed as part of the Derivative Works; within the Source form or documentation, if provided along with the Derivative Works; or, within a display generated by the Derivative Works, if and wherever such third-party notices normally appear. The contents of the NOTICE file are for informational purposes only and do not modify the License. You may add Your own attribution notices within Derivative Works that You distribute, alongside or as an addendum to the NOTICE text from the Work, provided that such additional attribution notices cannot be construed as modifying the License.

You may add Your own copyright statement to Your modifications and may provide additional or different license terms and conditions for use, reproduction, or distribution of Your modifications, or for any such Derivative Works as a whole, provided Your use, reproduction, and distribution of the Work otherwise complies with the conditions stated in this License.

5. Submission of Contributions. Unless You explicitly state otherwise, any Contribution intentionally submitted for inclusion in the Work by You to the Licensor shall be under the terms and conditions of this License, without any additional terms or conditions. Notwithstanding the above, nothing herein shall supersede or modify the terms of any separate license agreement you may have executed with Licensor regarding such Contributions.
6. Trademarks. This License does not grant permission to use the trade names, trademarks, service marks, or product names of the Licensor, except as required for reasonable and customary use in describing the origin of the Work and reproducing the content of the NOTICE file.
7. Disclaimer of Warranty. Unless required by applicable law or agreed to in writing, Licensor provides the Work (and each Contributor provides its Contributions) on an "AS IS" BASIS, WITHOUT WARRANTIES OR CONDITIONS OF ANY KIND, either express or implied, including, without limitation, any warranties or conditions of TITLE, NON-INFRINGEMENT, MERCHANTABILITY, or FITNESS FOR A PARTICULAR PURPOSE. You are solely responsible for determining the appropriateness of using or redistributing the Work and assume any risks associated with Your exercise of permissions under this License.
8. Limitation of Liability. In no event and under no legal theory, whether in tort (including negligence), contract, or otherwise, unless required by applicable law (such as deliberate and grossly negligent acts) or agreed to in writing, shall any Contributor be liable to You for damages, including any direct, indirect, special, incidental, or consequential damages of any character arising as a result of this License or out of the use or inability to use the Work (including but not limited to damages for loss of goodwill, work stoppage, computer failure or malfunction, or any and all other commercial damages or losses), even if such Contributor has been advised of the possibility of such damages.
9. Accepting Warranty or Additional Liability. While redistributing the Work or Derivative Works thereof, You may choose to offer, and charge a fee for, acceptance of support, warranty, indemnity, or other liability obligations and/or rights consistent with this License. However, in accepting such obligations, You may act only on Your own behalf and on Your sole responsibility, not on behalf of any other Contributor, and only if You agree to indemnify, defend, and hold each Contributor harmless for any liability incurred by, or claims asserted against, such Contributor by reason of your accepting any

such warranty or additional liability.
END OF TERMS AND CONDITIONS

---- Part 1: CMU/UCD copyright notice: (BSD like) ----

Copyright 1989, 1991, 1992 by Carnegie Mellon University

Derivative Work - 1996, 1998-2000

Copyright 1996, 1998-2000 The Regents of the University of California

All Rights Reserved

Permission to use, copy, modify and distribute this software and its documentation for any purpose and without fee is hereby granted, provided that the above copyright notice appears in all copies and that both that copyright notice and this permission notice appear in supporting documentation, and that the name of CMU and The Regents of the University of California not be used in advertising or publicity pertaining to distribution of the software without specific written permission.

CMU AND THE REGENTS OF THE UNIVERSITY OF CALIFORNIA DISCLAIM ALL WARRANTIES WITH REGARD TO THIS SOFTWARE, INCLUDING ALL IMPLIED WARRANTIES OF MERCHANTABILITY AND FITNESS. IN NO EVENT SHALL CMU OR THE REGENTS OF THE UNIVERSITY OF CALIFORNIA BE LIABLE FOR ANY SPECIAL, INDIRECT OR CONSEQUENTIAL DAMAGES OR ANY DAMAGES WHATSOEVER RESULTING FROM THE LOSS OF USE, DATA OR PROFITS, WHETHER IN AN ACTION OF CONTRACT, NEGLIGENCE OR OTHER TORTIOUS ACTION, ARISING OUT OF OR IN CONNECTION WITH THE USE OR PERFORMANCE OF THIS SOFTWARE.

---- Part 2: Networks Associates Technology, Inc copyright notice (BSD) ----

Copyright (c) 2001-2003, Networks Associates Technology, Inc

All rights reserved.

Redistribution and use in source and binary forms, with or without modification, are permitted provided that the following conditions are met:

- * Redistributions of source code must retain the above copyright notice, this list of conditions and the following disclaimer.
- * Redistributions in binary form must reproduce the above copyright notice, this list of conditions and the following disclaimer in the documentation and/or other materials provided with the distribution.
- * Neither the name of the Networks Associates Technology, Inc nor the names of its contributors may be used to endorse or promote products derived from this software without specific prior written permission.

THIS SOFTWARE IS PROVIDED BY THE COPYRIGHT HOLDERS AND CONTRIBUTORS "AS IS" AND ANY EXPRESS OR IMPLIED WARRANTIES, INCLUDING, BUT NOT LIMITED TO, THE IMPLIED WARRANTIES OF MERCHANTABILITY AND FITNESS FOR A PARTICULAR PURPOSE ARE DISCLAIMED. IN NO EVENT SHALL THE COPYRIGHT HOLDERS OR CONTRIBUTORS BE LIABLE FOR ANY DIRECT, INDIRECT, INCIDENTAL, SPECIAL, EXEMPLARY, OR CONSEQUENTIAL DAMAGES (INCLUDING, BUT NOT LIMITED TO, PROCUREMENT OF SUBSTITUTE GOODS OR SERVICES; LOSS OF USE, DATA, OR PROFITS; OR BUSINESS INTERRUPTION) HOWEVER CAUSED AND ON ANY THEORY OF LIABILITY, WHETHER IN CONTRACT, STRICT LIABILITY, OR TORT (INCLUDING NEGLIGENCE OR OTHERWISE) ARISING IN ANY WAY OUT OF THE USE OF THIS SOFTWARE, EVEN IF ADVISED OF THE POSSIBILITY OF SUCH DAMAGE.

---- Part 3: Cambridge Broadband Ltd. copyright notice (BSD) -----

Portions of this code are copyright (c) 2001-2003, Cambridge Broadband Ltd.

All rights reserved.

Redistribution and use in source and binary forms, with or without modification, are permitted provided that the following conditions are met:

- * Redistributions of source code must retain the above copyright notice, this list of conditions and the following disclaimer.
- * Redistributions in binary form must reproduce the above copyright notice, this list of conditions and the following disclaimer in the documentation and/or other materials provided with the distribution.
- * The name of Cambridge Broadband Ltd. may not be used to endorse or promote products derived from this software without specific prior written permission.

THIS SOFTWARE IS PROVIDED BY THE COPYRIGHT HOLDER ``AS IS" AND ANY EXPRESS OR IMPLIED WARRANTIES, INCLUDING, BUT NOT LIMITED TO, THE IMPLIED WARRANTIES OF MERCHANTABILITY AND FITNESS FOR A PARTICULAR PURPOSE ARE DISCLAIMED. IN NO EVENT SHALL THE COPYRIGHT HOLDER BE LIABLE FOR ANY DIRECT, INDIRECT, INCIDENTAL, SPECIAL, EXEMPLARY, OR CONSEQUENTIAL DAMAGES (INCLUDING, BUT NOT LIMITED TO, PROCUREMENT OF SUBSTITUTE GOODS OR SERVICES; LOSS OF USE, DATA, OR PROFITS; OR BUSINESS INTERRUPTION) HOWEVER CAUSED AND ON ANY THEORY OF LIABILITY, WHETHER IN CONTRACT, STRICT LIABILITY, OR TORT (INCLUDING NEGLIGENCE OR OTHERWISE) ARISING IN ANY WAY OUT OF THE USE OF THIS SOFTWARE, EVEN IF ADVISED OF THE POSSIBILITY OF SUCH DAMAGE.

---- Part 4: Sun Microsystems, Inc. copyright notice (BSD) -----

Copyright c 2003 Sun Microsystems, Inc., 4150 Network Circle, Santa Clara, California 95054, U.S.A. All rights reserved.

Use is subject to license terms below.

This distribution may include materials developed by third parties.

Sun, Sun Microsystems, the Sun logo and Solaris are trademarks or registered trademarks of Sun Microsystems, Inc. in the U.S. and other countries.

Redistribution and use in source and binary forms, with or without modification, are permitted provided that the following conditions are met:

- * Redistributions of source code must retain the above copyright notice, this list of conditions and the following disclaimer.
- * Redistributions in binary form must reproduce the above copyright notice, this list of conditions and the following disclaimer in the documentation and/or other materials provided with the distribution.
- * Neither the name of the Sun Microsystems, Inc. nor the names of its contributors may be used to endorse or promote products derived from this software without specific prior written permission.

THIS SOFTWARE IS PROVIDED BY THE COPYRIGHT HOLDERS AND CONTRIBUTORS ``AS IS" AND ANY EXPRESS OR IMPLIED WARRANTIES, INCLUDING, BUT NOT LIMITED TO, THE IMPLIED WARRANTIES OF MERCHANTABILITY AND FITNESS FOR A PARTICULAR PURPOSE ARE DISCLAIMED. IN NO EVENT SHALL THE COPYRIGHT HOLDERS OR CONTRIBUTORS BE LIABLE FOR ANY DIRECT, INDIRECT, INCIDENTAL, SPECIAL, EXEMPLARY, OR CONSEQUENTIAL DAMAGES (INCLUDING, BUT NOT LIMITED TO, PROCUREMENT OF SUBSTITUTE GOODS OR

SERVICES; LOSS OF USE, DATA, OR PROFITS; OR BUSINESS INTERRUPTION) HOWEVER CAUSED AND ON ANY THEORY OF LIABILITY, WHETHER IN CONTRACT, STRICT LIABILITY, OR TORT (INCLUDING NEGLIGENCE OR OTHERWISE) ARISING IN ANY WAY OUT OF THE USE OF THIS SOFTWARE, EVEN IF ADVISED OF THE POSSIBILITY OF SUCH DAMAGE.

---- Part 5: Sparta, Inc copyright notice (BSD) ----

Copyright (c) 2003-2012, Sparta, Inc

All rights reserved.

Redistribution and use in source and binary forms, with or without modification, are permitted provided that the following conditions are met:

- * Redistributions of source code must retain the above copyright notice, this list of conditions and the following disclaimer.
- * Redistributions in binary form must reproduce the above copyright notice, this list of conditions and the following disclaimer in the documentation and/or other materials provided with the distribution.
- * Neither the name of Sparta, Inc nor the names of its contributors may be used to endorse or promote products derived from this software without specific prior written permission.

THIS SOFTWARE IS PROVIDED BY THE COPYRIGHT HOLDERS AND CONTRIBUTORS ``AS IS" AND ANY EXPRESS OR IMPLIED WARRANTIES, INCLUDING, BUT NOT LIMITED TO, THE IMPLIED WARRANTIES OF MERCHANTABILITY AND FITNESS FOR A PARTICULAR PURPOSE ARE DISCLAIMED. IN NO EVENT SHALL THE COPYRIGHT HOLDERS OR CONTRIBUTORS BE LIABLE FOR ANY DIRECT, INDIRECT, INCIDENTAL, SPECIAL, EXEMPLARY, OR CONSEQUENTIAL DAMAGES (INCLUDING, BUT NOT LIMITED TO, PROCUREMENT OF SUBSTITUTE GOODS OR SERVICES; LOSS OF USE, DATA, OR PROFITS; OR BUSINESS INTERRUPTION) HOWEVER CAUSED AND ON ANY THEORY OF LIABILITY, WHETHER IN CONTRACT, STRICT LIABILITY, OR TORT (INCLUDING NEGLIGENCE OR OTHERWISE) ARISING IN ANY WAY OUT OF THE USE OF THIS SOFTWARE, EVEN IF ADVISED OF THE POSSIBILITY OF SUCH DAMAGE.

---- Part 6: Cisco/BUPTNIC copyright notice (BSD) ----

Copyright (c) 2004, Cisco, Inc and Information Network Center of Beijing University of Posts and Telecommunications.

All rights reserved.

Redistribution and use in source and binary forms, with or without modification, are permitted provided that the following conditions are met:

- * Redistributions of source code must retain the above copyright notice, this list of conditions and the following disclaimer.
- * Redistributions in binary form must reproduce the above copyright notice, this list of conditions and the following disclaimer in the documentation and/or other materials provided with the distribution.
- * Neither the name of Cisco, Inc, Beijing University of Posts and Telecommunications, nor the names of their contributors may be used to endorse or promote products derived from this software without specific prior written permission.

THIS SOFTWARE IS PROVIDED BY THE COPYRIGHT HOLDERS AND CONTRIBUTORS ``AS IS" AND ANY EXPRESS OR IMPLIED WARRANTIES, INCLUDING, BUT NOT LIMITED TO, THE IMPLIED WARRANTIES OF MERCHANTABILITY AND FITNESS FOR A PARTICULAR PURPOSE

ARE DISCLAIMED. IN NO EVENT SHALL THE COPYRIGHT HOLDERS OR CONTRIBUTORS BE LIABLE FOR ANY DIRECT, INDIRECT, INCIDENTAL, SPECIAL, EXEMPLARY, OR CONSEQUENTIAL DAMAGES (INCLUDING, BUT NOT LIMITED TO, PROCUREMENT OF SUBSTITUTE GOODS OR SERVICES; LOSS OF USE, DATA, OR PROFITS; OR BUSINESS INTERRUPTION) HOWEVER CAUSED AND ON ANY THEORY OF LIABILITY, WHETHER IN CONTRACT, STRICT LIABILITY, OR TORT (INCLUDING NEGLIGENCE OR OTHERWISE) ARISING IN ANY WAY OUT OF THE USE OF THIS SOFTWARE, EVEN IF ADVISED OF THE POSSIBILITY OF SUCH DAMAGE.

---- Part 7: Fabasoft R&D Software GmbH & Co KG copyright notice (BSD) ----

Copyright (c) Fabasoft R&D Software GmbH & Co KG, 2003 oss@fabasoft.com

Author: Bernhard Penz <bernhard.penz@fabasoft.com>

Redistribution and use in source and binary forms, with or without modification, are permitted provided that the following conditions are met:

- * Redistributions of source code must retain the above copyright notice, this list of conditions and the following disclaimer.
- * Redistributions in binary form must reproduce the above copyright notice, this list of conditions and the following disclaimer in the documentation and/or other materials provided with the distribution.
- * The name of Fabasoft R&D Software GmbH & Co KG or any of its subsidiaries, brand or product names may not be used to endorse or promote products derived from this software without specific prior written permission.

THIS SOFTWARE IS PROVIDED BY THE COPYRIGHT HOLDER "AS IS" AND ANY EXPRESS OR IMPLIED WARRANTIES, INCLUDING, BUT NOT LIMITED TO, THE IMPLIED WARRANTIES OF MERCHANTABILITY AND FITNESS FOR A PARTICULAR PURPOSE ARE DISCLAIMED. IN NO EVENT SHALL THE COPYRIGHT HOLDER BE LIABLE FOR ANY DIRECT, INDIRECT, INCIDENTAL, SPECIAL, EXEMPLARY, OR CONSEQUENTIAL DAMAGES (INCLUDING, BUT NOT LIMITED TO, PROCUREMENT OF SUBSTITUTE GOODS OR SERVICES; LOSS OF USE, DATA, OR PROFITS; OR BUSINESS INTERRUPTION) HOWEVER CAUSED AND ON ANY THEORY OF LIABILITY, WHETHER IN CONTRACT, STRICT LIABILITY, OR TORT (INCLUDING NEGLIGENCE OR OTHERWISE) ARISING IN ANY WAY OUT OF THE USE OF THIS SOFTWARE, EVEN IF ADVISED OF THE POSSIBILITY OF SUCH DAMAGE.

---- Part 8: Apple Inc. copyright notice (BSD) ----

Copyright (c) 2007 Apple Inc. All rights reserved.

Redistribution and use in source and binary forms, with or without modification, are permitted provided that the following conditions are met:

1. Redistributions of source code must retain the above copyright notice, this list of conditions and the following disclaimer.
2. Redistributions in binary form must reproduce the above copyright notice, this list of conditions and the following disclaimer in the documentation and/or other materials provided with the distribution.
3. Neither the name of Apple Inc. ("Apple") nor the names of its contributors may be used to endorse or promote products derived from this software without specific prior written permission.

THIS SOFTWARE IS PROVIDED BY APPLE AND ITS CONTRIBUTORS "AS IS" AND ANY EXPRESS OR IMPLIED WARRANTIES, INCLUDING, BUT NOT LIMITED TO, THE IMPLIED WARRANTIES

OF MERCHANTABILITY AND FITNESS FOR A PARTICULAR PURPOSE ARE DISCLAIMED. IN NO EVENT SHALL APPLE OR ITS CONTRIBUTORS BE LIABLE FOR ANY DIRECT, INDIRECT, INCIDENTAL, SPECIAL, EXEMPLARY, OR CONSEQUENTIAL DAMAGES (INCLUDING, BUT NOT LIMITED TO, PROCUREMENT OF SUBSTITUTE GOODS OR SERVICES; LOSS OF USE, DATA, OR PROFITS; OR BUSINESS INTERRUPTION) HOWEVER CAUSED AND ON ANY THEORY OF LIABILITY, WHETHER IN CONTRACT, STRICT LIABILITY, OR TORT (INCLUDING NEGLIGENCE OR OTHERWISE) ARISING IN ANY WAY OUT OF THE USE OF THIS SOFTWARE, EVEN IF ADVISED OF THE POSSIBILITY OF SUCH DAMAGE.

---- Part 9: ScienceLogic, LLC copyright notice (BSD) ----

Copyright (c) 2009, ScienceLogic, LLC

All rights reserved.

Redistribution and use in source and binary forms, with or without modification, are permitted provided that the following conditions are met:

- * Redistributions of source code must retain the above copyright notice, this list of conditions and the following disclaimer.
- * Redistributions in binary form must reproduce the above copyright notice, this list of conditions and the following disclaimer in the documentation and/or other materials provided with the distribution.
- * Neither the name of ScienceLogic, LLC nor the names of its contributors may be used to endorse or promote products derived from this software without specific prior written permission.

THIS SOFTWARE IS PROVIDED BY THE COPYRIGHT HOLDERS AND CONTRIBUTORS "AS IS" AND ANY EXPRESS OR IMPLIED WARRANTIES, INCLUDING, BUT NOT LIMITED TO, THE IMPLIED WARRANTIES OF MERCHANTABILITY AND FITNESS FOR A PARTICULAR PURPOSE ARE DISCLAIMED. IN NO EVENT SHALL THE COPYRIGHT HOLDERS OR CONTRIBUTORS BE LIABLE FOR ANY DIRECT, INDIRECT, INCIDENTAL, SPECIAL, EXEMPLARY, OR CONSEQUENTIAL DAMAGES (INCLUDING, BUT NOT LIMITED TO, PROCUREMENT OF SUBSTITUTE GOODS OR SERVICES; LOSS OF USE, DATA, OR PROFITS; OR BUSINESS INTERRUPTION) HOWEVER CAUSED AND ON ANY THEORY OF LIABILITY, WHETHER IN CONTRACT, STRICT LIABILITY, OR TORT (INCLUDING NEGLIGENCE OR OTHERWISE) ARISING IN ANY WAY OUT OF THE USE OF THIS SOFTWARE, EVEN IF ADVISED OF THE POSSIBILITY OF SUCH DAMAGE.

---- Part 10: Lennart Poettering copyright notice (BSD-like) ----

Copyright 2010 Lennart Poettering

Permission is hereby granted, free of charge, to any person obtaining a copy of this software and associated documentation files (the "Software"), to deal in the Software without restriction, including without limitation the rights to use, copy, modify, merge, publish, distribute, sublicense, and/or sell copies of the Software, and to permit persons to whom the Software is furnished to do so, subject to the following conditions:

The above copyright notice and this permission notice shall be included in all copies or substantial portions of the Software.

THE SOFTWARE IS PROVIDED "AS IS", WITHOUT WARRANTY OF ANY KIND, EXPRESS OR IMPLIED, INCLUDING BUT NOT LIMITED TO THE WARRANTIES OF MERCHANTABILITY, FITNESS FOR A PARTICULAR PURPOSE AND NONINFRINGEMENT. IN NO EVENT SHALL THE AUTHORS OR COPYRIGHT HOLDERS BE LIABLE FOR ANY CLAIM, DAMAGES OR OTHER LIABILITY, WHETHER IN AN ACTION OF CONTRACT, TORT OR OTHERWISE, ARISING FROM, OUT OF OR IN CONNECTION WITH THE SOFTWARE OR THE USE OR OTHER DEALINGS IN THE SOFTWARE.

---- Part 11: IETF copyright notice (BSD) ----

Copyright (c) 2013 IETF Trust and the persons identified as authors of the code. All rights reserved.

Redistribution and use in source and binary forms, with or without modification, are permitted provided that the following conditions are met:

* Redistributions of source code must retain the above copyright notice, this list of conditions and the following disclaimer.

* Redistributions in binary form must reproduce the above copyright notice, this list of conditions and the following disclaimer in the documentation and/or other materials provided with the distribution.

* Neither the name of Internet Society, IETF or IETF Trust, nor the names of specific contributors, may be used to endorse or promote products derived from this software without specific prior written permission.

THIS SOFTWARE IS PROVIDED BY THE COPYRIGHT HOLDERS AND CONTRIBUTORS "AS IS" AND ANY EXPRESS OR IMPLIED WARRANTIES, INCLUDING, BUT NOT LIMITED TO, THE IMPLIED WARRANTIES OF MERCHANTABILITY AND FITNESS FOR A PARTICULAR PURPOSE ARE DISCLAIMED. IN NO EVENT SHALL THE COPYRIGHT OWNER OR CONTRIBUTORS BE LIABLE FOR ANY DIRECT, INDIRECT, INCIDENTAL, SPECIAL, EXEMPLARY, OR CONSEQUENTIAL DAMAGES (INCLUDING, BUT NOT LIMITED TO, PROCUREMENT OF SUBSTITUTE GOODS OR SERVICES; LOSS OF USE, DATA, OR PROFITS; OR BUSINESS INTERRUPTION) HOWEVER CAUSED AND ON ANY THEORY OF LIABILITY, WHETHER IN CONTRACT, STRICT LIABILITY, OR TORT (INCLUDING NEGLIGENCE OR OTHERWISE) ARISING IN ANY WAY OUT OF THE USE OF THIS SOFTWARE, EVEN IF ADVISED OF THE POSSIBILITY OF SUCH DAMAGE.

---- Part 12: Arista Networks copyright notice (BSD) ----

Copyright (c) 2013, Arista Networks, Inc.

All rights reserved.

Redistribution and use in source and binary forms, with or without modification, are permitted provided that the following conditions are met:

* Redistributions of source code must retain the above copyright notice, this list of conditions and the following disclaimer.

* Redistributions in binary form must reproduce the above copyright notice, this list of conditions and the following disclaimer in the documentation and/or other materials provided with the distribution.

* Neither the name of Arista Networks, Inc. nor the names of its contributors may be used to endorse or promote products derived from this software without specific prior written permission.

THIS SOFTWARE IS PROVIDED BY THE COPYRIGHT HOLDERS AND CONTRIBUTORS "AS IS" AND ANY EXPRESS OR IMPLIED WARRANTIES, INCLUDING, BUT NOT LIMITED TO, THE IMPLIED WARRANTIES OF MERCHANTABILITY AND FITNESS FOR A PARTICULAR PURPOSE ARE DISCLAIMED. IN NO EVENT SHALL THE COPYRIGHT HOLDERS OR CONTRIBUTORS BE LIABLE FOR ANY DIRECT, INDIRECT, INCIDENTAL, SPECIAL, EXEMPLARY, OR CONSEQUENTIAL DAMAGES (INCLUDING, BUT NOT LIMITED TO, PROCUREMENT OF SUBSTITUTE GOODS OR SERVICES; LOSS OF USE, DATA, OR PROFITS; OR BUSINESS INTERRUPTION) HOWEVER CAUSED AND ON ANY THEORY OF LIABILITY, WHETHER IN CONTRACT, STRICT LIABILITY, OR TORT (INCLUDING NEGLIGENCE OR OTHERWISE) ARISING IN ANY WAY OUT OF THE USE OF THIS SOFTWARE, EVEN IF ADVISED OF THE POSSIBILITY OF SUCH DAMAGE.

---- Part 13: VMware, Inc. copyright notice (BSD) ----

Copyright (c) 2016, VMware, Inc.

All rights reserved.

Redistribution and use in source and binary forms, with or without modification, are permitted provided that the following conditions are met:

* Redistributions of source code must retain the above copyright notice, this list of conditions and the following disclaimer.

* Redistributions in binary form must reproduce the above copyright notice, this list of conditions and the following disclaimer in the documentation and/or other materials provided with the distribution.

* Neither the name of VMware, Inc. nor the names of its contributors may be used to endorse or promote products derived from this software without specific prior written permission.

THIS SOFTWARE IS PROVIDED BY THE COPYRIGHT HOLDERS AND CONTRIBUTORS "AS IS" AND ANY EXPRESS OR IMPLIED WARRANTIES, INCLUDING, BUT NOT LIMITED TO, THE IMPLIED WARRANTIES OF MERCHANTABILITY AND FITNESS FOR A PARTICULAR PURPOSE ARE DISCLAIMED. IN NO EVENT SHALL THE COPYRIGHT HOLDERS OR CONTRIBUTORS BE LIABLE FOR ANY DIRECT, INDIRECT, INCIDENTAL, SPECIAL, EXEMPLARY, OR CONSEQUENTIAL DAMAGES (INCLUDING, BUT NOT LIMITED TO, PROCUREMENT OF SUBSTITUTE GOODS OR SERVICES; LOSS OF USE, DATA, OR PROFITS; OR BUSINESS INTERRUPTION) HOWEVER CAUSED AND ON ANY THEORY OF LIABILITY, WHETHER IN CONTRACT, STRICT LIABILITY, OR TORT (INCLUDING NEGLIGENCE OR OTHERWISE) ARISING IN ANY WAY OUT OF THE USE OF THIS SOFTWARE, EVEN IF ADVISED OF THE POSSIBILITY OF SUCH DAMAGE.

---- Part 14: USC/Information Sciences Institute copyright notice (BSD) ----

Copyright (c) 2017-2018, Information Sciences Institute

All rights reserved.

Redistribution and use in source and binary forms, with or without modification, are permitted provided that the following conditions are met:

* Redistributions of source code must retain the above copyright notice, this list of conditions and the following disclaimer.

* Redistributions in binary form must reproduce the above copyright notice, this list of conditions and the following disclaimer in the documentation and/or other materials provided with the distribution.

* Neither the name of Information Sciences Institute nor the names of its contributors may be used to endorse or promote products derived from this software without specific prior written permission.

THIS SOFTWARE IS PROVIDED BY THE COPYRIGHT HOLDERS AND CONTRIBUTORS "AS IS" AND ANY EXPRESS OR IMPLIED WARRANTIES, INCLUDING, BUT NOT LIMITED TO, THE IMPLIED WARRANTIES OF MERCHANTABILITY AND FITNESS FOR A PARTICULAR PURPOSE ARE DISCLAIMED. IN NO EVENT SHALL THE COPYRIGHT HOLDERS OR CONTRIBUTORS BE LIABLE FOR ANY DIRECT, INDIRECT, INCIDENTAL, SPECIAL, EXEMPLARY, OR CONSEQUENTIAL DAMAGES (INCLUDING, BUT NOT LIMITED TO,

PROCUREMENT OF SUBSTITUTE GOODS OR SERVICES; LOSS OF USE, DATA, OR PROFITS; OR BUSINESS INTERRUPTION) HOWEVER CAUSED AND ON ANY THEORY OF LIABILITY, WHETHER IN CONTRACT, STRICT LIABILITY, OR TORT (INCLUDING NEGLIGENCE OR OTHERWISE) ARISING IN ANY WAY OUT OF THE USE OF THIS SOFTWARE, EVEN IF ADVISED OF THE POSSIBILITY OF SUCH DAMAGE.

MIT License

Copyright (c) 1998, 1999, 2000 Thai Open Source Software Center Ltd

Permission is hereby granted, free of charge, to any person obtaining a copy of this software and associated documentation files (the "Software"), to deal in the Software without restriction, including without limitation the rights to use, copy, modify, merge, publish, distribute, sublicense, and/or sell copies of the Software, and to permit persons to whom the Software is furnished to do so, subject to the following conditions:

The above copyright notice and this permission notice shall be included in all copies or substantial portions of the Software.

THE SOFTWARE IS PROVIDED "AS IS", WITHOUT WARRANTY OF ANY KIND, EXPRESS OR IMPLIED, INCLUDING BUT NOT LIMITED TO THE WARRANTIES OF MERCHANTABILITY, FITNESS FOR A PARTICULAR PURPOSE AND NONINFRINGEMENT. IN NO EVENT SHALL THE AUTHORS OR COPYRIGHT HOLDERS BE LIABLE FOR ANY CLAIM, DAMAGES OR OTHER LIABILITY, WHETHER IN AN ACTION OF CONTRACT, TORT OR OTHERWISE, ARISING FROM, OUT OF OR IN CONNECTION WITH THE SOFTWARE OR THE USE OR OTHER DEALINGS IN THE SOFTWARE.

Copyright 2000 Computing Research Labs, New Mexico State University

Copyright 2001-2015 Francesco Zappa Nardelli

Permission is hereby granted, free of charge, to any person obtaining a copy of this software and associated documentation files (the "Software"), to deal in the Software without restriction, including without limitation the rights to use, copy, modify, merge, publish, distribute, sublicense, and/or sell copies of the Software, and to permit persons to whom the Software is furnished to do so, subject to the following conditions:

The above copyright notice and this permission notice shall be included in all copies or substantial portions of the Software.

THE SOFTWARE IS PROVIDED "AS IS", WITHOUT WARRANTY OF ANY KIND, EXPRESS OR IMPLIED, INCLUDING BUT NOT LIMITED TO THE WARRANTIES OF MERCHANTABILITY, FITNESS FOR A PARTICULAR PURPOSE AND NONINFRINGEMENT. IN NO EVENT SHALL THE COMPUTING RESEARCH LAB OR NEW MEXICO STATE UNIVERSITY BE LIABLE FOR ANY CLAIM, DAMAGES OR OTHER LIABILITY, WHETHER IN AN ACTION OF CONTRACT, TORT OR OTHERWISE, ARISING FROM, OUT OF OR IN CONNECTION WITH THE SOFTWARE OR THE USE OR OTHER DEALINGS IN THE SOFTWARE.

Written by Joel Sherrill <joel@OARcorp.com>.

COPYRIGHT (c) 1989-2000.

On-Line Applications Research Corporation (OAR).

Permission to use, copy, modify, and distribute this software for any purpose without fee is hereby granted, provided that this entire notice is included in all copies of any software which is or includes a copy or modification of this software.

THIS SOFTWARE IS BEING PROVIDED "AS IS", WITHOUT ANY EXPRESS OR IMPLIED WARRANTY. IN PARTICULAR, THE AUTHOR MAKES NO REPRESENTATION OR WARRANTY OF ANY KIND CONCERNING THE MERCHANTABILITY OF THIS SOFTWARE OR ITS FITNESS FOR ANY PARTICULAR PURPOSE.

(1) Red Hat Incorporated

Copyright (c) 1994-2009 Red Hat, Inc. All rights reserved.

This copyrighted material is made available to anyone wishing to use, modify, copy, or redistribute it subject to the terms and conditions of the BSD License. This program is distributed in the hope that it will be useful, but WITHOUT ANY WARRANTY expressed or implied, including the implied warranties of MERCHANTABILITY or FITNESS FOR A PARTICULAR PURPOSE. A copy of this license is available at <http://www.opensource.org/licenses>. Any Red Hat trademarks that are incorporated in the source code or documentation are not subject to the BSD License and may only be used or replicated with the express permission of Red Hat, Inc.

(2) University of California, Berkeley

Copyright (c) 1981-2000 The Regents of the University of California.

All rights reserved.

Redistribution and use in source and binary forms, with or without modification, are permitted provided that the following conditions are met:

- * Redistributions of source code must retain the above copyright notice, this list of conditions and the following disclaimer.
- * Redistributions in binary form must reproduce the above copyright notice, this list of conditions and the following disclaimer in the documentation and/or other materials provided with the distribution.
- * Neither the name of the University nor the names of its contributors may be used to endorse or promote products derived from this software without specific prior written permission.

THIS SOFTWARE IS PROVIDED BY THE COPYRIGHT HOLDERS AND CONTRIBUTORS "AS IS" AND ANY EXPRESS OR IMPLIED WARRANTIES, INCLUDING, BUT NOT LIMITED TO, THE IMPLIED WARRANTIES OF MERCHANTABILITY AND FITNESS FOR A PARTICULAR PURPOSE ARE DISCLAIMED. IN NO EVENT SHALL THE COPYRIGHT OWNER OR CONTRIBUTORS BE LIABLE FOR ANY DIRECT, INDIRECT, INCIDENTAL, SPECIAL, EXEMPLARY, OR CONSEQUENTIAL DAMAGES (INCLUDING, BUT NOT LIMITED TO, PROCUREMENT OF SUBSTITUTE GOODS OR SERVICES; LOSS OF USE, DATA, OR PROFITS; OR BUSINESS INTERRUPTION) HOWEVER CAUSED AND ON ANY THEORY OF LIABILITY, WHETHER IN CONTRACT, STRICT LIABILITY, OR TORT (INCLUDING NEGLIGENCE OR OTHERWISE) ARISING IN ANY WAY OUT OF THE USE OF THIS SOFTWARE, EVEN IF ADVISED OF THE POSSIBILITY OF SUCH DAMAGE.

The FreeType Project LICENSE

2006-Jan-27

Copyright 1996-2002, 2006 by

David Turner, Robert Wilhelm, and Werner Lemberg

Introduction

=====

The FreeType Project is distributed in several archive packages; some of them may contain, in addition to the FreeType font engine, various tools and contributions which rely on, or relate to, the FreeType Project.

This license applies to all files found in such packages, and which do not fall under their own explicit license. The license affects thus the FreeType font engine, the test programs, documentation and makefiles, at the very least.

This license was inspired by the BSD, Artistic, and IJG (Independent JPEG Group) licenses, which all encourage inclusion and use of free software in commercial and freeware products alike. As a consequence, its main points are that:

- o We don't promise that this software works. However, we will be interested in any kind of bug reports. ('as is' distribution)
- o You can use this software for whatever you want, in parts or full form, without having to pay us. ('royalty-free' usage)
- o You may not pretend that you wrote this software. If you use it, or only parts of it, in a program, you must acknowledge somewhere in your documentation that you have used the FreeType code. ('credits')

We specifically permit and encourage the inclusion of this software, with or without modifications, in commercial products.

We disclaim all warranties covering The FreeType Project and assume no liability related to The FreeType Project.

Finally, many people asked us for a preferred form for a credit/disclaimer to use in compliance with this license. We thus encourage you to use the following text:

""

Portions of this software are copyright © <year> The FreeType Project (www.freetype.org). All rights reserved.

""

Please replace <year> with the value from the FreeType version you actually use.

Legal Terms

=====

0. Definitions

Throughout this license, the terms 'package', 'FreeType Project', and 'FreeType archive' refer to the set of files originally distributed by the authors (David Turner, Robert Wilhelm, and Werner Lemberg) as the 'FreeType Project', be they named as alpha, beta or final release.

'You' refers to the licensee, or person using the project, where 'using' is a generic term including compiling the project's source code as well as linking it to form a 'program' or 'executable'.

This program is referred to as 'a program using the FreeType engine'.

This license applies to all files distributed in the original FreeType Project, including all source code, binaries and documentation, unless otherwise stated in the file in its original, unmodified form as distributed in the original archive.

If you are unsure whether or not a particular file is covered by this license, you must contact us to verify this.

The FreeType Project is copyright (C) 1996-2000 by David Turner, Robert Wilhelm, and Werner Lemberg. All rights reserved except as specified below.

1. No Warranty

THE FREETYPE PROJECT IS PROVIDED 'AS IS' WITHOUT WARRANTY OF ANY KIND, EITHER EXPRESS OR IMPLIED, INCLUDING, BUT NOT LIMITED TO, WARRANTIES OF MERCHANTABILITY AND FITNESS FOR A PARTICULAR PURPOSE. IN NO EVENT WILL ANY OF THE AUTHORS OR COPYRIGHT HOLDERS BE LIABLE FOR ANY DAMAGES CAUSED BY THE USE OR THE INABILITY TO USE, OF THE FREETYPE PROJECT.

2. Redistribution

This license grants a worldwide, royalty-free, perpetual and irrevocable right and license to use, execute, perform, compile, display, copy, create derivative works of, distribute and sublicense the FreeType Project (in both source and object code forms) and derivative works thereof for any purpose; and to authorize others to exercise some or all of the rights granted herein, subject to the following conditions:

- o Redistribution of source code must retain this license file ('FTL.TXT') unaltered; any additions, deletions or changes to the original files must be clearly indicated in accompanying documentation. The copyright notices of the unaltered, original files must be preserved in all copies of source files.

- o Redistribution in binary form must provide a disclaimer that states that the software is based in part of the work of the FreeType Team, in the distribution documentation. We also encourage you to put an URL to the FreeType web page in your documentation, though this isn't mandatory.

These conditions apply to any software derived from or based on the FreeType Project, not just the unmodified files. If you use our work, you must acknowledge us. However, no fee need be paid to us.

3. Advertising

Neither the FreeType authors and contributors nor you shall use the name of the other for commercial, advertising, or promotional purposes without specific prior written permission.

We suggest, but do not require, that you use one or more of the following phrases to refer to this software in your documentation or advertising materials: 'FreeType Project', 'FreeType Engine', 'FreeType library', or 'FreeType Distribution'.

As you have not signed this license, you are not required to accept it. However, as the FreeType Project is copyrighted material, only this license, or another one contracted with the authors, grants you the right to use, distribute, and modify it.

Therefore, by using, distributing, or modifying the FreeType Project, you indicate that you understand and accept all the terms of this license.

4. Contacts

There are two mailing lists related to FreeType:

o freetype@nongnu.org

Discusses general use and applications of FreeType, as well as future and wanted additions to the library and distribution.

If you are looking for support, start in this list if you haven't found anything to help you in the documentation.

o freetype-devel@nongnu.org

Discusses bugs, as well as engine internals, design issues, specific licenses, porting, etc.

Our home page can be found at

<http://www.freetype.org>

--- end of FTL.TXT ---

The TWAIN Toolkit is distributed as is. The developer and distributors of the TWAIN Toolkit expressly disclaim all implied, express or statutory warranties including, without limitation, the implied warranties of merchantability, noninfringement of third party rights and fitness for a particular purpose. Neither the developers nor the distributors will be liable for damages, whether direct, indirect, special, incidental, or consequential, as a result of the reproduction, modification, distribution or other use of the TWAIN Toolkit.

JSON for Modern C++

Copyright (c) 2013-2017 Niels Lohmann

Permission is hereby granted, free of charge, to any person obtaining a copy of this software and associated documentation files (the "Software"), to deal in the Software without restriction, including without limitation the rights to use, copy, modify, merge, publish, distribute, sublicense, and/or sell copies of the Software, and to permit persons to whom the Software is furnished to do so, subject to the following conditions:

The above copyright notice and this permission notice shall be included in all copies or substantial portions of the Software.

THE SOFTWARE IS PROVIDED "AS IS", WITHOUT WARRANTY OF ANY KIND, EXPRESS OR IMPLIED, INCLUDING BUT NOT LIMITED TO THE WARRANTIES OF MERCHANTABILITY, FITNESS FOR A PARTICULAR PURPOSE AND NONINFRINGEMENT. IN NO EVENT SHALL THE AUTHORS OR COPYRIGHT HOLDERS BE LIABLE FOR ANY CLAIM, DAMAGES OR OTHER LIABILITY, WHETHER IN AN ACTION OF CONTRACT, TORT OR OTHERWISE, ARISING FROM, OUT OF OR IN CONNECTION WITH THE SOFTWARE OR THE USE OR OTHER DEALINGS IN THE SOFTWARE.

Copyright (c) 2011 - 2015 ARM LIMITED

All rights reserved.

Redistribution and use in source and binary forms, with or without modification, are permitted provided that the following conditions are met:

- Redistributions of source code must retain the above copyright notice, this list of conditions and the following disclaimer.

- Redistributions in binary form must reproduce the above copyright notice, this list of conditions and the following disclaimer in the documentation and/or other materials provided with the distribution.
- Neither the name of ARM nor the names of its contributors may be used to endorse or promote products derived from this software without specific prior written permission.

THIS SOFTWARE IS PROVIDED BY THE COPYRIGHT HOLDERS AND CONTRIBUTORS "AS IS" AND ANY EXPRESS OR IMPLIED WARRANTIES, INCLUDING, BUT NOT LIMITED TO, THE IMPLIED WARRANTIES OF MERCHANTABILITY AND FITNESS FOR A PARTICULAR PURPOSE ARE DISCLAIMED. IN NO EVENT SHALL COPYRIGHT HOLDERS AND CONTRIBUTORS BE LIABLE FOR ANY DIRECT, INDIRECT, INCIDENTAL, SPECIAL, EXEMPLARY, OR CONSEQUENTIAL DAMAGES (INCLUDING, BUT NOT LIMITED TO, PROCUREMENT OF SUBSTITUTE GOODS OR SERVICES; LOSS OF USE, DATA, OR PROFITS; OR BUSINESS INTERRUPTION) HOWEVER CAUSED AND ON ANY THEORY OF LIABILITY, WHETHER IN CONTRACT, STRICT LIABILITY, OR TORT (INCLUDING NEGLIGENCE OR OTHERWISE) ARISING IN ANY WAY OUT OF THE USE OF THIS SOFTWARE, EVEN IF ADVISED OF THE POSSIBILITY OF SUCH DAMAGE.

Copyright (c) 2014, Kenneth MacKay

All rights reserved.

Redistribution and use in source and binary forms, with or without modification, are permitted provided that the following conditions are met:

- * Redistributions of source code must retain the above copyright notice, this list of conditions and the following disclaimer.
- * Redistributions in binary form must reproduce the above copyright notice, this list of conditions and the following disclaimer in the documentation and/or other materials provided with the distribution.

THIS SOFTWARE IS PROVIDED BY THE COPYRIGHT HOLDERS AND CONTRIBUTORS "AS IS" AND ANY EXPRESS OR IMPLIED WARRANTIES, INCLUDING, BUT NOT LIMITED TO, THE IMPLIED WARRANTIES OF MERCHANTABILITY AND FITNESS FOR A PARTICULAR PURPOSE ARE DISCLAIMED. IN NO EVENT SHALL THE COPYRIGHT HOLDER OR CONTRIBUTORS BE LIABLE FOR ANY DIRECT, INDIRECT, INCIDENTAL, SPECIAL, EXEMPLARY, OR CONSEQUENTIAL DAMAGES (INCLUDING, BUT NOT LIMITED TO, PROCUREMENT OF SUBSTITUTE GOODS OR SERVICES; LOSS OF USE, DATA, OR PROFITS; OR BUSINESS INTERRUPTION) HOWEVER CAUSED AND ON ANY THEORY OF LIABILITY, WHETHER IN CONTRACT, STRICT LIABILITY, OR TORT (INCLUDING NEGLIGENCE OR OTHERWISE) ARISING IN ANY WAY OUT OF THE USE OF THIS SOFTWARE, EVEN IF ADVISED OF THE POSSIBILITY OF SUCH DAMAGE.

Copyright (c) 2006, CRYPTOGRAMS by <appro@openssl.org> All rights reserved.

Redistribution and use in source and binary forms, with or without modification, are permitted provided that the following conditions are met:

- * Redistributions of source code must retain copyright notices, this list of conditions and the following disclaimer.
- * Redistributions in binary form must reproduce the above copyright notice, this list of conditions and the following disclaimer in the documentation and/or other materials provided with the distribution.
- * Neither the name of the CRYPTOGRAMS nor the names of its copyright holder and contributors may be used to endorse or promote products derived from this software without specific prior written permission.

ALTERNATIVELY, provided that this notice is retained in full, this product may be distributed under the terms of the GNU General Public License (GPL), in which case the provisions of the GPL apply INSTEAD OF those given above.

THIS SOFTWARE IS PROVIDED BY THE COPYRIGHT HOLDER AND CONTRIBUTORS "AS IS" AND ANY EXPRESS OR IMPLIED WARRANTIES, INCLUDING, BUT NOT LIMITED TO, THE IMPLIED WARRANTIES OF MERCHANTABILITY AND FITNESS FOR A PARTICULAR PURPOSE ARE DISCLAIMED. IN NO EVENT SHALL THE COPYRIGHT OWNER OR CONTRIBUTORS BE LIABLE FOR ANY DIRECT, INDIRECT, INCIDENTAL, SPECIAL, EXEMPLARY, OR CONSEQUENTIAL DAMAGES (INCLUDING, BUT NOT LIMITED TO, PROCUREMENT OF SUBSTITUTE GOODS OR SERVICES; LOSS OF USE, DATA, OR PROFITS; OR BUSINESS INTERRUPTION) HOWEVER CAUSED AND ON ANY THEORY OF LIABILITY, WHETHER IN CONTRACT, STRICT LIABILITY, OR TORT (INCLUDING NEGLIGENCE OR OTHERWISE) ARISING IN ANY WAY OUT OF THE USE OF THIS SOFTWARE, EVEN IF ADVISED OF THE POSSIBILITY OF SUCH DAMAGE.

ISC License

Copyright (c) 2013-2017

Frank Denis <j at pureftpd dot org>

Permission to use, copy, modify, and/or distribute this software for any purpose with or without fee is hereby granted, provided that the above copyright notice and this permission notice appear in all copies.

THE SOFTWARE IS PROVIDED "AS IS" AND THE AUTHOR DISCLAIMS ALL WARRANTIES WITH REGARD TO THIS SOFTWARE INCLUDING ALL IMPLIED WARRANTIES OF MERCHANTABILITY AND FITNESS. IN NO EVENT SHALL THE AUTHOR BE LIABLE FOR ANY SPECIAL, DIRECT, INDIRECT, OR CONSEQUENTIAL DAMAGES OR ANY DAMAGES WHATSOEVER RESULTING FROM LOSS OF USE, DATA OR PROFITS, WHETHER IN AN ACTION OF CONTRACT, NEGLIGENCE OR OTHER TORTIOUS ACTION, ARISING OUT OF OR IN CONNECTION WITH THE USE OR PERFORMANCE OF THIS SOFTWARE.

Copyright (c) 2008 The NetBSD Foundation, Inc.

All rights reserved.

This code is derived from software contributed to The NetBSD Foundation by Lennart Augustsson (lennart@augustsson.net) at Carlstedt Research & Technology.

Redistribution and use in source and binary forms, with or without modification, are permitted provided that the following conditions are met:

1. Redistributions of source code must retain the above copyright notice, this list of conditions and the following disclaimer.
2. Redistributions in binary form must reproduce the above copyright notice, this list of conditions and the following disclaimer in the documentation and/or other materials provided with the distribution.

THIS SOFTWARE IS PROVIDED BY THE NETBSD FOUNDATION, INC. AND CONTRIBUTORS "AS IS" AND ANY EXPRESS OR IMPLIED WARRANTIES, INCLUDING, BUT NOT LIMITED TO, THE IMPLIED WARRANTIES OF MERCHANTABILITY AND FITNESS FOR A PARTICULAR

PURPOSE ARE DISCLAIMED. IN NO EVENT SHALL THE FOUNDATION OR CONTRIBUTORS BE LIABLE FOR ANY DIRECT, INDIRECT, INCIDENTAL, SPECIAL, EXEMPLARY, OR CONSEQUENTIAL DAMAGES (INCLUDING, BUT NOT LIMITED TO, PROCUREMENT OF SUBSTITUTE GOODS OR SERVICES; LOSS OF USE, DATA, OR PROFITS; OR BUSINESS INTERRUPTION) HOWEVER CAUSED AND ON ANY THEORY OF LIABILITY, WHETHER IN CONTRACT, STRICT LIABILITY, OR TORT (INCLUDING NEGLIGENCE OR OTHERWISE) ARISING IN ANY WAY OUT OF THE USE OF THIS SOFTWARE, EVEN IF ADVISED OF THE POSSIBILITY OF SUCH DAMAGE.

Copyright (c) 2000 Intel Corporation

All rights reserved.

Redistribution and use in source and binary forms, with or without modification, are permitted provided that the following conditions are met:

- * Redistributions of source code must retain the above copyright notice, this list of conditions and the following disclaimer.
- * Redistributions in binary form must reproduce the above copyright notice, this list of conditions and the following disclaimer in the documentation and/or other materials provided with the distribution.
- * Neither name of Intel Corporation nor the names of its contributors may be used to endorse or promote products derived from this software without specific prior written permission.

THIS SOFTWARE IS PROVIDED BY THE COPYRIGHT HOLDERS AND CONTRIBUTORS "AS IS" AND ANY EXPRESS OR IMPLIED WARRANTIES, INCLUDING, BUT NOT LIMITED TO, THE IMPLIED WARRANTIES OF MERCHANTABILITY AND FITNESS FOR A PARTICULAR PURPOSE ARE DISCLAIMED. IN NO EVENT SHALL INTEL OR CONTRIBUTORS BE LIABLE FOR ANY DIRECT, INDIRECT, INCIDENTAL, SPECIAL, EXEMPLARY, OR CONSEQUENTIAL DAMAGES (INCLUDING, BUT NOT LIMITED TO, PROCUREMENT OF SUBSTITUTE GOODS OR SERVICES; LOSS OF USE, DATA, OR PROFITS; OR BUSINESS INTERRUPTION) HOWEVER CAUSED AND ON ANY THEORY OF LIABILITY, WHETHER IN CONTRACT, STRICT LIABILITY, OR TORT (INCLUDING NEGLIGENCE OR OTHERWISE) ARISING IN ANY WAY OUT OF THE USE OF THIS SOFTWARE, EVEN IF ADVISED OF THE POSSIBILITY OF SUCH DAMAGE.

Lua

Copyright © 1994–2014 Lua.org, PUC-Rio.

Permission is hereby granted, free of charge, to any person obtaining a copy of this software and associated

documentation files (the "Software"), to deal in the Software without restriction, including without limitation the

rights to use, copy, modify, merge, publish, distribute, sublicense, and/or sell copies of the Software, and to

permit persons to whom the Software is furnished to do so, subject to the following conditions:

The above copyright notice and this permission notice shall be included in all copies or substantial portions of the Software.

THE SOFTWARE IS PROVIDED "AS IS", WITHOUT WARRANTY OF ANY KIND, EXPRESS OR IMPLIED, INCLUDING BUT NOT LIMITED TO THE WARRANTIES OF MERCHANTABILITY, FITNESS FOR A PARTICULAR PURPOSE AND NONINFRINGEMENT. IN NO EVENT SHALL THE AUTHORS OR COPYRIGHT HOLDERS BE LIABLE FOR ANY CLAIM, DAMAGES OR OTHER LIABILITY, WHETHER IN AN ACTION OF CONTRACT, TORT OR OTHERWISE, ARISING FROM, OUT OF OR IN CONNECTION WITH THE SOFTWARE OR THE USE OR OTHER DEALINGS IN THE SOFTWARE.

LuaSocket

LuaSocket 2.0.2 license
Copyright © 2004-2007 Diego Nehab

Permission is hereby granted, free of charge, to any person obtaining a copy of this software and associated documentation files (the "Software"), to deal in the Software without restriction, including without limitation the rights to use, copy, modify, merge, publish, distribute, sublicense, and/or sell copies of the Software, and to permit persons to whom the Software is furnished to do so, subject to the following conditions:

The above copyright notice and this permission notice shall be included in all copies or substantial portions of the Software.

THE SOFTWARE IS PROVIDED "AS IS", WITHOUT WARRANTY OF ANY KIND, EXPRESS OR IMPLIED, INCLUDING BUT NOT LIMITED TO THE WARRANTIES OF MERCHANTABILITY, FITNESS FOR A PARTICULAR PURPOSE AND NONINFRINGEMENT. IN NO EVENT SHALL THE AUTHORS OR COPYRIGHT HOLDERS BE LIABLE FOR ANY CLAIM, DAMAGES OR OTHER LIABILITY, WHETHER IN AN ACTION OF CONTRACT, TORT OR OTHERWISE, ARISING FROM, OUT OF OR IN CONNECTION WITH THE SOFTWARE OR THE USE OR OTHER DEALINGS IN THE SOFTWARE.

LuneScript

Copyright (c) 2018 ifritJP

Permission is hereby granted, free of charge, to any person obtaining a copy of this software and associated documentation files (the "Software"), to deal in the Software without restriction, including without limitation the rights to use, copy, modify, merge, publish, distribute, sublicense, and/or sell copies of the Software, and to permit persons to whom the Software is furnished to do so, subject to the following conditions:

The above copyright notice and this permission notice shall be included in all copies or substantial portions of the Software.

THE SOFTWARE IS PROVIDED "AS IS", WITHOUT WARRANTY OF ANY KIND, EXPRESS OR IMPLIED, INCLUDING BUT NOT LIMITED TO THE WARRANTIES OF MERCHANTABILITY, FITNESS FOR A PARTICULAR PURPOSE AND NONINFRINGEMENT. IN NO EVENT SHALL THE AUTHORS OR COPYRIGHT HOLDERS BE LIABLE FOR ANY CLAIM, DAMAGES OR OTHER LIABILITY, WHETHER IN AN ACTION OF CONTRACT, TORT OR OTHERWISE, ARISING FROM, OUT OF OR IN CONNECTION WITH THE SOFTWARE OR THE USE OR OTHER DEALINGS IN THE SOFTWARE.

Copyright (c) 2002-2019, Jouni Malinen <j@w1.fi> and contributors
All Rights Reserved.

This software may be distributed, used, and modified under the terms of BSD license:

Redistribution and use in source and binary forms, with or without modification, are permitted provided that the following conditions are met:

1. Redistributions of source code must retain the above copyright notice, this list of conditions and the following disclaimer.
2. Redistributions in binary form must reproduce the above copyright notice, this list of conditions and the following disclaimer in the documentation and/or other materials provided with the distribution.
3. Neither the name(s) of the above-listed copyright holder(s) nor the names of its contributors may be used to endorse or promote products derived from this software without specific prior written permission.

THIS SOFTWARE IS PROVIDED BY THE COPYRIGHT HOLDERS AND CONTRIBUTORS "AS IS" AND ANY EXPRESS OR IMPLIED WARRANTIES, INCLUDING, BUT NOT LIMITED TO, THE IMPLIED WARRANTIES OF MERCHANTABILITY AND FITNESS FOR A PARTICULAR PURPOSE ARE DISCLAIMED. IN NO EVENT SHALL THE COPYRIGHT OWNER OR CONTRIBUTORS BE LIABLE FOR ANY DIRECT, INDIRECT, INCIDENTAL, SPECIAL, EXEMPLARY, OR CONSEQUENTIAL DAMAGES (INCLUDING, BUT NOT LIMITED TO, PROCUREMENT OF SUBSTITUTE GOODS OR SERVICES; LOSS OF USE, DATA, OR PROFITS; OR BUSINESS INTERRUPTION) HOWEVER CAUSED AND ON ANY THEORY OF LIABILITY, WHETHER IN CONTRACT, STRICT LIABILITY, OR TORT (INCLUDING NEGLIGENCE OR OTHERWISE) ARISING IN ANY WAY OUT OF THE USE OF THIS SOFTWARE, EVEN IF ADVISED OF THE POSSIBILITY OF SUCH DAMAGE.

Copyright (C) 2019, Broadcom Corporation. All Rights Reserved.

Permission to use, copy, modify, and/or distribute this software for any purpose with or without fee is hereby granted, provided that the above copyright notice and this permission notice appear in all copies.

THE SOFTWARE IS PROVIDED "AS IS" AND THE AUTHOR DISCLAIMS ALL WARRANTIES WITH REGARD TO THIS SOFTWARE INCLUDING ALL IMPLIED WARRANTIES OF MERCHANTABILITY AND FITNESS. IN NO EVENT SHALL THE AUTHOR BE LIABLE FOR ANY SPECIAL, DIRECT, INDIRECT, OR CONSEQUENTIAL DAMAGES OR ANY DAMAGES WHATSOEVER RESULTING FROM LOSS OF USE, DATA OR PROFITS, WHETHER IN AN ACTION OF CONTRACT, NEGLIGENCE OR OTHER TORTIOUS ACTION, ARISING OUT OF OR IN CONNECTION WITH THE USE OR PERFORMANCE OF THIS SOFTWARE.

The certificate files "Amazon Root CA 1", "Amazon Root CA 2", "Amazon Root CA 4" are licensed under a Creative Commons Attribution-NoDerivatives 4.0 International License.

The following applies only to products supporting Wi-Fi.

(c) 2009-2013 by Jeff Mott. All rights reserved.

Redistribution and use in source and binary forms, with or without modification, are permitted provided that the following conditions are met:

- * Redistributions of source code must retain the above copyright notice, this list of conditions, and the following disclaimer.
- * Redistributions in binary form must reproduce the above copyright notice, this list of conditions, and the following disclaimer in the documentation or other materials provided with the distribution.
- * Neither the name CryptoJS nor the names of its contributors may be used to endorse or promote products derived from this software without specific prior written permission.

THIS SOFTWARE IS PROVIDED BY THE COPYRIGHT HOLDERS AND CONTRIBUTORS "AS IS," AND ANY EXPRESS OR IMPLIED WARRANTIES, INCLUDING, BUT NOT LIMITED TO, THE IMPLIED WARRANTIES OF MERCHANTABILITY AND FITNESS FOR A PARTICULAR PURPOSE, ARE DISCLAIMED. IN NO EVENT SHALL THE COPYRIGHT HOLDER OR CONTRIBUTORS BE LIABLE FOR ANY DIRECT, INDIRECT, INCIDENTAL, SPECIAL, EXEMPLARY, OR CONSEQUENTIAL DAMAGES (INCLUDING, BUT NOT LIMITED TO, PROCUREMENT OF SUBSTITUTE GOODS OR SERVICES; LOSS OF USE, DATA, OR PROFITS; OR BUSINESS INTERRUPTION) HOWEVER CAUSED AND ON ANY THEORY OF LIABILITY, WHETHER IN CONTRACT, STRICT LIABILITY, OR TORT (INCLUDING NEGLIGENCE OR OTHERWISE) ARISING IN ANY WAY OUT OF THE USE OF THIS SOFTWARE, EVEN IF ADVISED OF THE POSSIBILITY OF SUCH DAMAGE.

Copyright 2008, Google Inc.

All rights reserved.

Redistribution and use in source and binary forms, with or without modification, are permitted provided that the following conditions are met:

- * Redistributions of source code must retain the above copyright notice, this list of conditions and the following disclaimer.
- * Redistributions in binary form must reproduce the above copyright notice, this list of conditions and the following disclaimer in the documentation and/or other materials provided with the distribution.

* Neither the name of Google Inc. nor the names of its contributors may be used to endorse or promote products derived from this software without specific prior written permission.

THIS SOFTWARE IS PROVIDED BY THE COPYRIGHT HOLDERS AND CONTRIBUTORS AS IS AND ANY EXPRESS OR IMPLIED WARRANTIES, INCLUDING, BUT NOT LIMITED TO, THE IMPLIED WARRANTIES OF MERCHANTABILITY AND FITNESS FOR A PARTICULAR PURPOSE ARE DISCLAIMED. IN NO EVENT SHALL THE COPYRIGHT OWNER OR CONTRIBUTORS BE LIABLE FOR ANY DIRECT, INDIRECT, INCIDENTAL, SPECIAL, EXEMPLARY, OR CONSEQUENTIAL DAMAGES (INCLUDING, BUT NOT LIMITED TO, PROCUREMENT OF SUBSTITUTE GOODS OR SERVICES; LOSS OF USE, DATA, OR PROFITS; OR BUSINESS INTERRUPTION) HOWEVER CAUSED AND ON ANY THEORY OF LIABILITY, WHETHER IN CONTRACT, STRICT LIABILITY, OR TORT (INCLUDING NEGLIGENCE OR OTHERWISE) ARISING IN ANY WAY OUT OF THE USE OF THIS SOFTWARE, EVEN IF ADVISED OF THE POSSIBILITY OF SUCH DAMAGE.

Copyright (c) 1998-2010, Brian Gladman, Worcester, UK. All rights reserved.

The redistribution and use of this software (with or without changes) is allowed without the payment of fees or royalties provided that: source code distributions include the above copyright notice, this list of conditions and the following disclaimer; binary distributions include the above copyright notice, this list of conditions and the following disclaimer in their documentation.

This software is provided 'as is' with no explicit or implied warranties in respect of its operation, including, but not limited to, correctness and fitness for purpose.

Disclaimer: IMPORTANT: This Apple software is supplied to you, by Apple Inc. ("Apple"), in your capacity as a current, and in good standing, Licensee in the MFi Licensing Program. Use of this Apple software is governed by and subject to the terms and conditions of your MFi License, including, but not limited to, the restrictions specified in the provision entitled "Public Software", and is further subject to your agreement to the following additional terms, and your agreement that the use, installation, modification or redistribution of this Apple software constitutes acceptance of these additional terms. If you do not agree with these additional terms, please do not use, install, modify or redistribute this Apple software.

Subject to all of these terms and in consideration of your agreement to abide by them, Apple grants you, for as long as you are a current and in good-standing MFi Licensee, a personal, non-exclusive license, under Apple's copyrights in this original Apple software (the "Apple Software"), to use, reproduce, and modify the Apple Software in source form, and to use, reproduce, modify, and redistribute the Apple Software, with or without modifications, in binary form. While you may not redistribute the Apple Software in source form, should you redistribute the Apple Software in binary form, you must retain this notice and the following text and disclaimers in all such redistributions of the Apple Software. Neither the name, trademarks, service marks, or logos of Apple Inc. may be used to endorse or promote products derived from the Apple Software without specific prior written permission from Apple. Except as expressly stated in this notice, no other rights or licenses, express or implied, are granted by Apple herein, including but not limited to any patent rights that

may be infringed by your derivative works or by other works in which the Apple Software may be incorporated.

Unless you explicitly state otherwise, if you provide any ideas, suggestions, recommendations, bug fixes or enhancements to Apple in connection with this software ("Feedback"), you hereby grant to Apple a non-exclusive, fully paid-up, perpetual, irrevocable, worldwide license to make, use, reproduce, incorporate, modify, display, perform, sell, make or have made derivative works of, distribute (directly or indirectly) and sublicense, such Feedback in connection with Apple products and services. Providing this Feedback is voluntary, but if you do provide Feedback to Apple, you acknowledge and agree that Apple may exercise the license granted above without the payment of royalties or further consideration to Participant.

The Apple Software is provided by Apple on an "AS IS" basis. APPLE MAKES NO WARRANTIES, EXPRESS OR IMPLIED, INCLUDING WITHOUT LIMITATION THE IMPLIED WARRANTIES OF NON-INFRINGEMENT, MERCHANTABILITY AND FITNESS FOR A PARTICULAR PURPOSE, REGARDING THE APPLE SOFTWARE OR ITS USE AND OPERATION ALONE OR IN COMBINATION WITH YOUR PRODUCTS.

IN NO EVENT SHALL APPLE BE LIABLE FOR ANY SPECIAL, INDIRECT, INCIDENTAL OR CONSEQUENTIAL DAMAGES (INCLUDING, BUT NOT LIMITED TO, PROCUREMENT OF SUBSTITUTE GOODS OR SERVICES; LOSS OF USE, DATA, OR PROFITS; OR BUSINESS INTERRUPTION) ARISING IN ANY WAY OUT OF THE USE, REPRODUCTION, MODIFICATION AND/OR DISTRIBUTION OF THE APPLE SOFTWARE, HOWEVER CAUSED AND WHETHER UNDER THEORY OF CONTRACT, TORT (INCLUDING NEGLIGENCE), STRICT LIABILITY OR OTHERWISE, EVEN IF APPLE HAS BEEN ADVISED OF THE POSSIBILITY OF SUCH DAMAGE.

Copyright (C) 2009 Apple Inc. All Rights Reserved.

Copyright (c) 2012-2013 Apple Inc. All rights reserved.

Copyright (C) 2013 Apple Inc. All Rights Reserved.

The following applies only to products supporting PIXUS Cloud Link, PIXMA Cloud Link, or MAXIFY Cloud Link.

THE BASIC LIBRARY FUNCTIONS

Written by: Philip Hazel

Email local part: ph10

Email domain: cam.ac.uk

University of Cambridge Computing Service, Cambridge, England.

Copyright (c) 1997-2012 University of Cambridge

All rights reserved.

PCRE JUST-IN-TIME COMPILATION SUPPORT

Written by: Zoltan Herczeg
Email local part: hzmester
Email domain: freemail.hu
Copyright(c) 2010-2012 Zoltan Herczeg
All rights reserved.

STACK-LESS JUST-IN-TIME COMPILER

Written by: Zoltan Herczeg
Email local part: hzmester
Email domain: freemail.hu
Copyright(c) 2009-2012 Zoltan Herczeg
All rights reserved.

THE C++ WRAPPER FUNCTIONS

Contributed by: Google Inc.
Copyright (c) 2007-2012, Google Inc.
All rights reserved.

THE "BSD" LICENCE

-----Redistribution and use in source and binary forms, with or without modification, are permitted provided that the following conditions are met:

* Redistributions of source code must retain the above copyright notice, this list of conditions and the following disclaimer.

* Redistributions in binary form must reproduce the above copyright notice, this list of conditions and the following disclaimer in the documentation and/or other materials provided with the distribution.

* Neither the name of the University of Cambridge nor the name of Google Inc. nor the names of their contributors may be used to endorse or promote products derived from this software without specific prior written permission.

THIS SOFTWARE IS PROVIDED BY THE COPYRIGHT HOLDERS AND CONTRIBUTORS "AS IS" AND ANY EXPRESS OR IMPLIED WARRANTIES, INCLUDING, BUT NOT LIMITED TO, THE IMPLIED WARRANTIES OF MERCHANTABILITY AND FITNESS FOR A PARTICULAR PURPOSE ARE DISCLAIMED. IN NO EVENT SHALL THE COPYRIGHT OWNER OR CONTRIBUTORS BE

LIABLE FOR ANY DIRECT, INDIRECT, INCIDENTAL, SPECIAL, EXEMPLARY, OR CONSEQUENTIAL DAMAGES (INCLUDING, BUT NOT LIMITED TO, PROCUREMENT OF SUBSTITUTE GOODS OR SERVICES; LOSS OF USE, DATA, OR PROFITS; OR BUSINESS INTERRUPTION) HOWEVER CAUSED AND ON ANY THEORY OF LIABILITY, WHETHER IN CONTRACT, STRICT LIABILITY, OR TORT (INCLUDING NEGLIGENCE OR OTHERWISE) ARISING IN ANY WAY OUT OF THE USE OF THIS SOFTWARE, EVEN IF ADVISED OF THE POSSIBILITY OF SUCH DAMAGE.

This software is based in part on the work of the Independent JPEG Group.

Basic Operations

► Printer Parts

- Front
- Back / Side
- Top Cover (Inside)
- Operation Panel
- Printer Stand
- Roll Unit

► Using the Printer

- Turning the Printer On and Off
- Loading Rolls in the Printer
- Loading Sheets in the Printer
- Using the Basket on the Printer Stand
- Storing the Basket on the Printer Stand
- Using the Roll Unit for Media Take-Up
- Stopping Printing
- Pausing Printing

Printer Parts

- **Front**
- **Back / Side**
- **Top Cover (Inside)**
- **Operation Panel**
- **Printer Stand**
- **Roll Unit**

Front

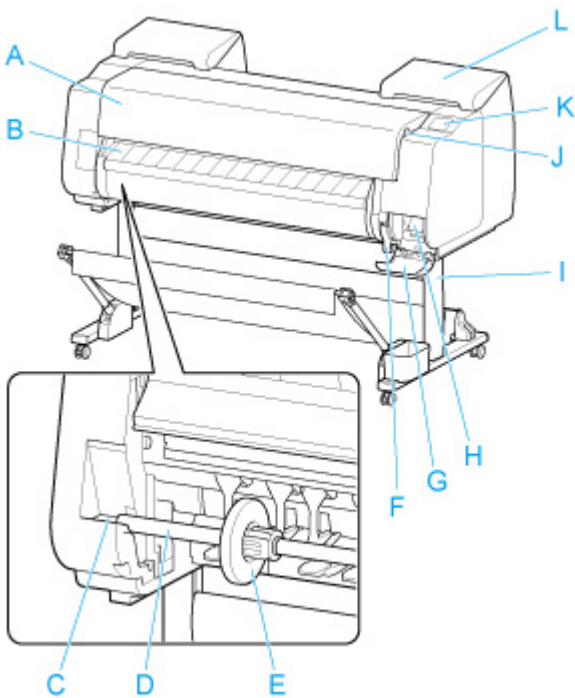

A: Top Cover

Open this cover to install the print head, load paper, and remove any jammed paper from inside the printer as needed.

➔ [Top Cover \(Inside\)](#)

B: Output Guide

Guides printed documents as they are ejected. Open this guide when loading a roll.

C: Roll holder Slot

Slide the Roll Holder into this slot.

D: Roll Holder

➔ [Roll Holder Set](#)

E: Holder Stopper

Secure the roll on the Roll Holder with this part.

F: Release Lever

To release paper retainer, lift the lever.

G: Maintenance Cartridge Cover

Open this cover to replace the maintenance cartridge.

H: Maintenance Cartridge

➔ [Maintenance Cartridge](#)

I: Printer Stand

A stand that holds the printer. Equipped with casters to facilitate moving it.

➔ [Printer Stand](#)

J: USB flash drive port

Insert a USB flash drive to this port.

K: Touch Screen

Use this screen to operate the printer and check the printer status.

➔ [Operation Panel](#)

L: Ink Tank Cover

Open this cover to replace the ink tank.

➔ [Ink Tank Cover \(Inside\)](#)

Roll Holder Set

Load roll paper on the roll holder and then load the holder in the printer. You can use the roll holder with both 2-inch and 3-inch paper cores. However, if using 3-inch core roll paper, attach the 3-inch paper core attachment.

➔ [Loading Rolls on the Roll Holder](#)

- GP-6600S / GP-566S : Roll Holder Set RH2-66
- GP-4600S / GP-546S : Roll Holder Set RH2-46
- GP-2600S / GP-526S : Roll Holder Set RH2-29
 - Roll Holder (for 2- and 3-inch paper cores)

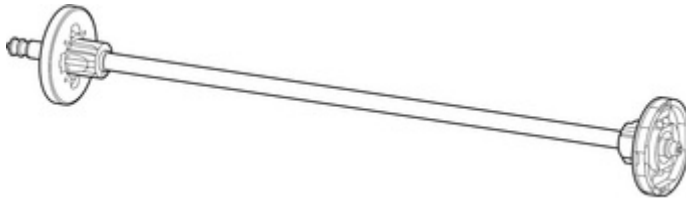

- 3-Inch Paper Core Attachment (x2)



Maintenance Cartridge

Model number: MC-30

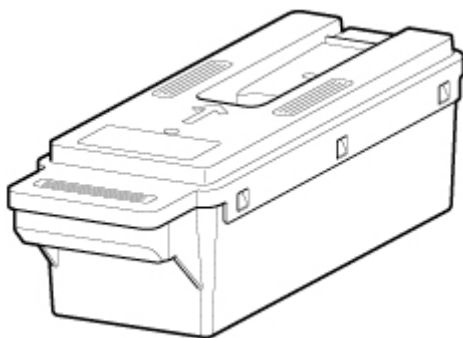

Absorbs ink used for cleaning.

➔ [Replacing the Maintenance Cartridge](#)

»» Important

- When purchasing, check the Model number.

Ink Tank Cover (Inside)

Left Side

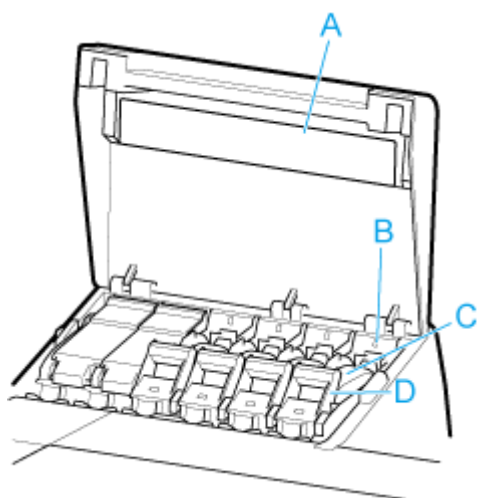

Right Side

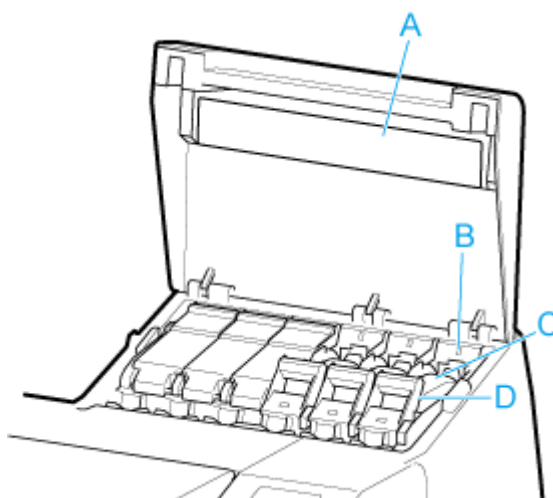

A: Ink Color Label

Load an ink tank that matches the color and name on this label.

B: Ink Lamp

Indicates the state of the ink tank as follows.

- **On**

The ink tank is installed correctly.

- **Off**

No ink tank is installed, or the ink level detection function is disabled.

- **Flashing**

Ink tank is empty.

▶▶▶ Note

- When there is little ink left, the ink lamp is lit and  appears on the touch screen.

C: Ink Tank

➔ [Ink Tanks](#)

D: Ink Tank Lock Lever

A lever that locks the ink tank in place and protects it. Lift and lower the lever when replacing an ink tank. To open it, lift the stopper of the lever until it stops, and then push it down toward the front. To close it, push it down until it clicks into place.

Ink Tanks

The printer supports the following ink tanks.

➔ [Replacing Ink Tanks](#)

- 160 ml (5.4 fl oz)

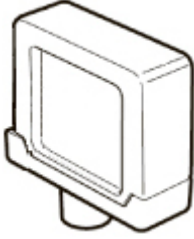

- 330 ml (11.2 fl oz)

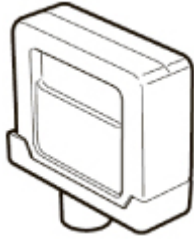

- 700 ml (23.7 fl oz)

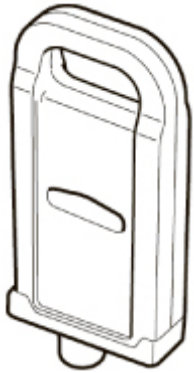

►► Important

- When purchasing, check the Model number.
 - ➔ [Checking the Ink Tank Model Number](#)

Back / Side

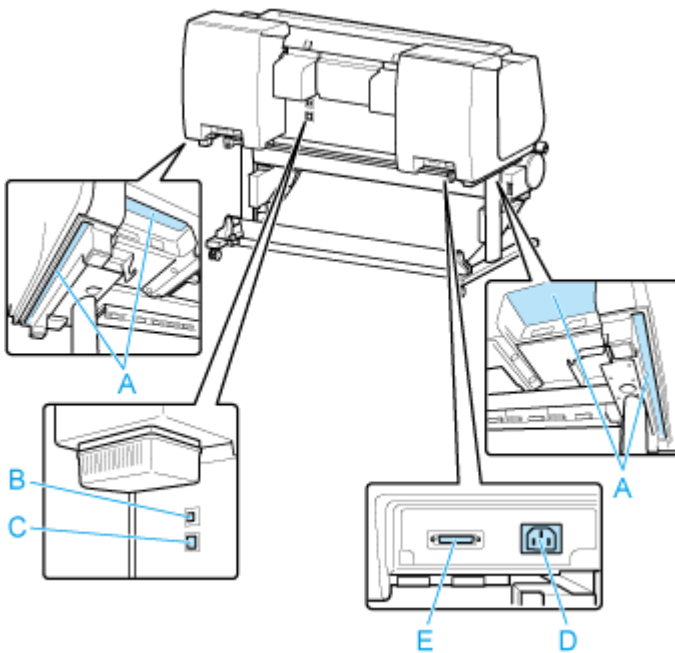

A: Carrying Grips

When carrying the printer, have six people hold it by these handles under both sides.

B: USB Port

Connect a USB cable to this port. The printer is compatible with Hi-Speed USB connections.

C: Wired LAN Connector

Connect an Ethernet cable to this port. The lamp is lit if the Ethernet cable is connected correctly and communication is possible between the computer and printer.

D: Power Cord Connector

Connect the power cord to this connector.

E: Roll Unit Power Supply Inlet

Connect the connection cord for the roll unit.

Top Cover (Inside)

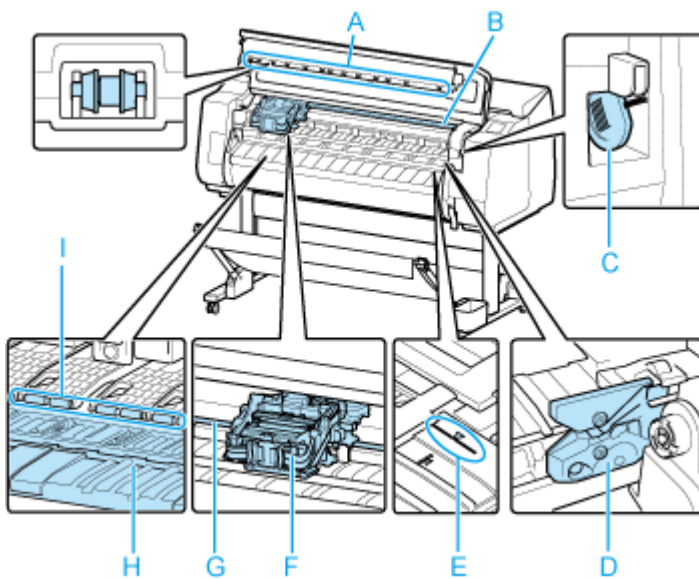

A: Top Cover Roller

Prevents paper from rising when ejected.

B: Internal Light

Lights automatically when the top cover is opened or during printing.

C: Cleaning Brush

When cleaning inside the printer under the top cover, use this brush to sweep away paper dust on the platen.

D: Cutter Blade

➡ [Cutter Blade](#)

E: Paper Alignment Line

Align paper with this line when loading it.

F: Carriage

Moves the print head. It serves a key role in printing.

➡ [Carriage](#)

G: Carriage Shaft

The Carriage slides along this shaft.

H: Platen

The print head moves across the platen to print. Vacuum holes on the platen hold paper in place.

I: Paper Retainer

This retainer holds paper as it is fed.

Cutter Blade

Model number: CT-07

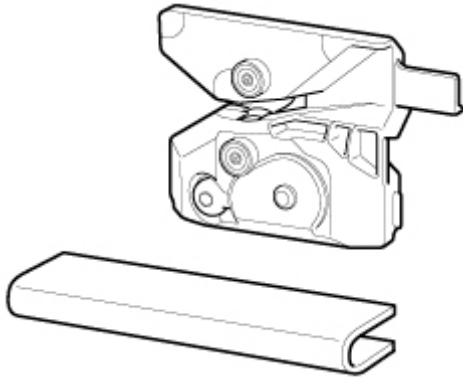

A round-bladed cutter for automatic paper cutting.

This cutter blade comes with a part for securing the cutter blade during installation.

➔ [Replacing the Cutter Blade](#)

➤➤➤ Important

- When purchasing, check the Model number.

Carriage

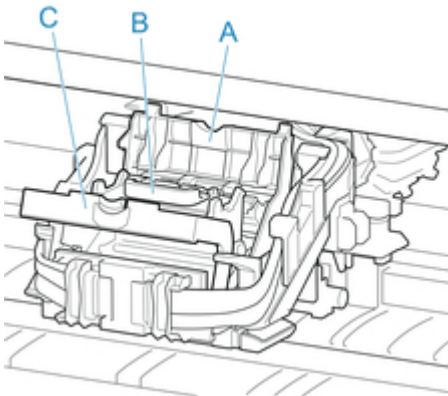

A: Print Head Locking Cover

Secures the print head.

B: Print Head

➔ [Print Head](#)

C: Print Head Lock Lever

Lock print head locking cover.

Print Head

Model number: PF-10

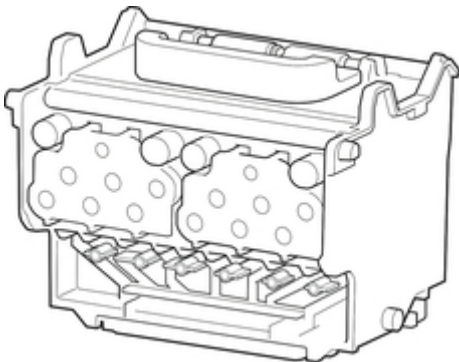

The print head is equipped with ink nozzles.

➔ [Replacing the Print Head](#)

➤➤➤ Important

- When purchasing, check the Model number.

Operation Panel

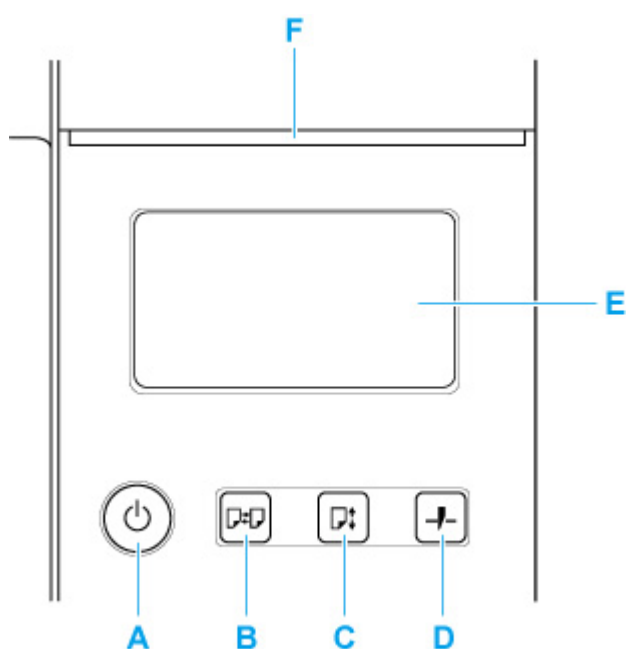

A: ON button / ON lamp

Turns the printer on and off.

➔ [Turning the Printer On and Off](#)

The ON lamp is lit when the printer is on or in Sleep mode.

B: Load button

Loads the paper when it is set or replaced.

- ➔ [Loading Rolls in the Printer](#)
- ➔ [Loading Roll Paper in the Roll Unit](#)
- ➔ [Loading Sheets in the Printer](#)

C: Feed button

Changes the paper position when the roll paper is loaded.

➔ [Feeding Roll Paper Manually](#)

D: Cut button

Cuts the paper when the roll paper is loaded.

➔ [Cutting Roll Paper](#)

E: Touch Screen

Shows printer menus, as well as the printer status and messages. You can select menu items and display buttons by gently touching the screen with your fingertip.

➔ [Home Screen Menu Composition](#)

F: Status lamp

- Flashing (white)

During printing, this lamp flashes when the printer is receiving or processing print jobs. Otherwise, this lamp flashes when the print job is paused or the printer is updating the firmware.

- Lit (orange)

A warning message is displayed.

- Flashing (orange)

An error message is displayed.

- Off

There are no active print jobs, warnings, or errors.

»» Note

- When the printer is in Sleep mode, to restore the display, press the buttons on the operation panel or touch the touch screen.
- When Operation panel lock is enabled, touch screen operations are invalid. For details on Operation panel lock, see [Changeable Setting Items Using Remote UI](#).

Printer Stand

The following Stand can be used with the printer.

- GP-2600S / GP-526S : Printer Stand SD-21

The GP-6600S, GP-4600S, GP-566S, and GP-546S models come with the printer stand included.

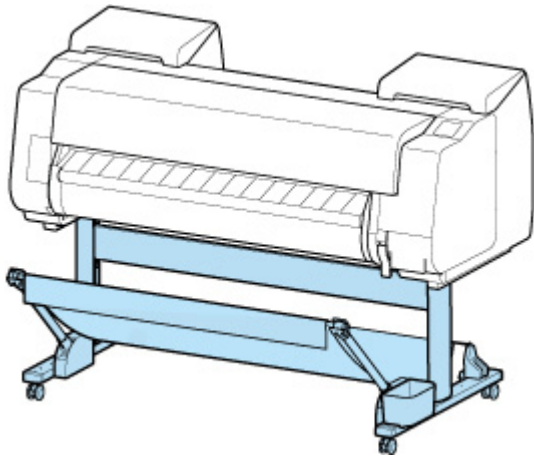

Stand Parts

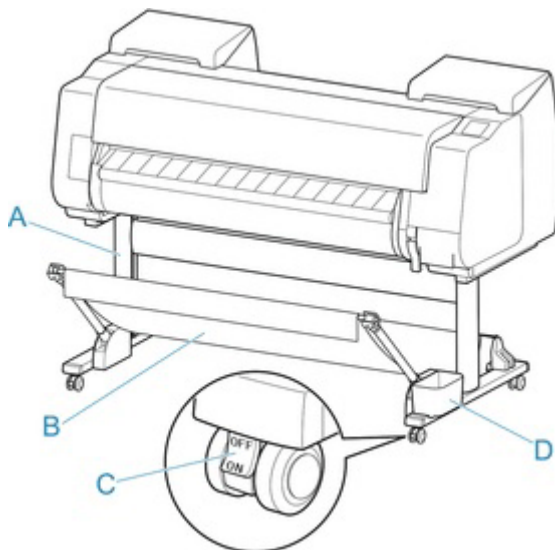

A: Stand Unit

A stand that holds the printer. Equipped with casters to facilitate moving the printer.

B: Basket

Catches the ejected printed documents.

➔ [Parts of the Basket](#)

C: Locking Caster

The casters can be locked securely. When moving the printer, be sure to unlock the 4 casters. If you move it while the locking casters are locked, the floor may become scratched.

D: Accessory Pocket

Stores the printer's accessories.

Parts of the Basket

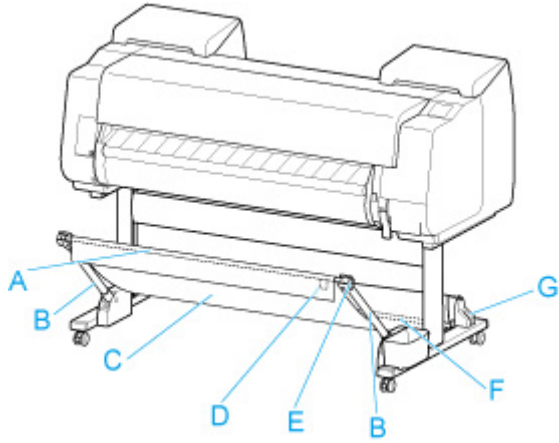

A: Basket Rod (tag side)

Secures the cloth basket to the tips of the basket arm.

B: Basket Arm

Retains the basket rod (tag side).

By changing the length and the angle, you can make the basket suitable for various conditions.

C: Basket Cloth

A cloth tray that catches ejected documents.

D: White Tag

Marks indicating basket attachment orientation.

E: Basket Rewind Button

Press this button when rewinding the basket after it has been wound on the basket rod (tag side).

F: Basket Rod (cord side)

Secures the cloth basket on the rod holder.

G: Rod Holder

Retains the basket rod (cord side).

▶▶▶ Note

- For details on using the basket, see "[Using the Basket on the Printer Stand](#)" and "[Storing the Basket on the Printer Stand](#)."

Roll Unit

The roll unit functions as a feed device that can accommodate an additional roll for a total of two rolls on the printer and as a take-up device that automatically takes up the printed roll paper. Switch between these two functions depending on the circumstances.

You can use the following roll unit with this printer.

- GP-6600S / GP-566S : Roll Unit RU-63
- GP-4600S / GP-546S : Roll Unit RU-43
- GP-2600S / GP-526S : Roll Unit RU-23

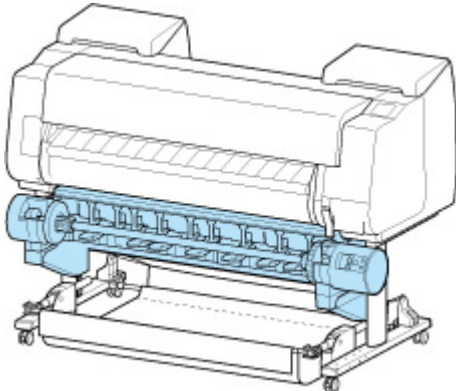

Parts of the Roll Unit

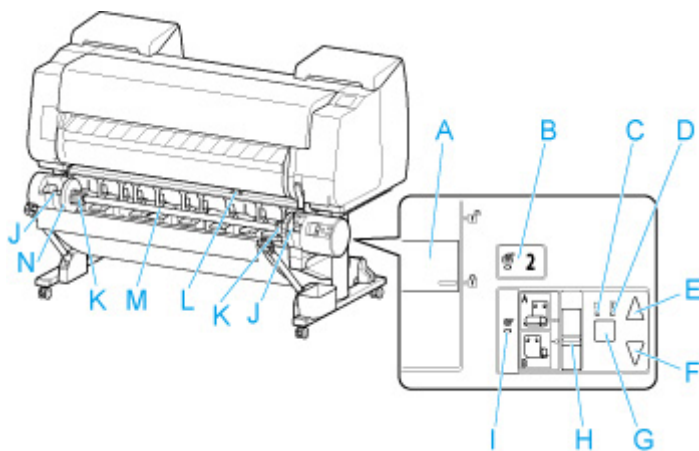

A: Roll Holder Lock Switch

Locks and releases the Roll Holder loaded in the roll unit.

B: Feed Mode Lamp

Lights up when you have selected the feed mode on the roll unit.

C: Auto Take-up Lamp

Lights up when the paper is being taken up.

D: Pause Lamp

Lights up when the paper winding is paused.

E: Take-up Button

You can rotate the roll unit the desired amount as long as winding is not in progress. When the winding direction is set to inward winding, the unit takes up the paper; when it is set to outward winding, the unit rewinds the paper.

F: Rewind Button

You can rotate the roll unit the desired amount as long as winding is not in progress. When the winding direction is set to inward winding, the unit rewinds the paper; when it is set to outward winding, the unit takes up the paper.

G: Auto Take-up/Pause Button

Pauses and resumes the taking up of paper.

H: Inward/Outward Winding Changeover Switch

Changes the winding direction when the paper is wound (inward winding and outward winding).

I: Take-up Mode Lamp

Lights up when you have selected the take-up mode on the roll unit.

J: Roll Holder Slot

Slide the Roll Holder into these guide grooves.

K: 3-Inch Paper Core Attachment

Attaches to the Roll Holder when you are using a roll paper with a 3-inch paper core.

L: Feed Flap Switch

Change the feed flap position depending on the roll unit mode.

M: Roll Holder

Load the roll on this holder.

N: Holder Stopper

This part secures the roll paper on the Roll Holder.

Using the Printer

- **Turning the Printer On and Off**
- **Loading Rolls in the Printer**
- **Loading Sheets in the Printer**
- **Using the Basket on the Printer Stand**
- **Storing the Basket on the Printer Stand**
- **Using the Roll Unit for Media Take-Up**
- **Stopping Printing**
- **Pausing Printing**

Turning the Printer On and Off

Turning the printer on

1. Press **ON** button to turn on printer.

The **ON** button lights up and the printer will now start up.

The Canon logo appears on the touch screen, and then "**Starting the system...Please wait momentarily**" appears.

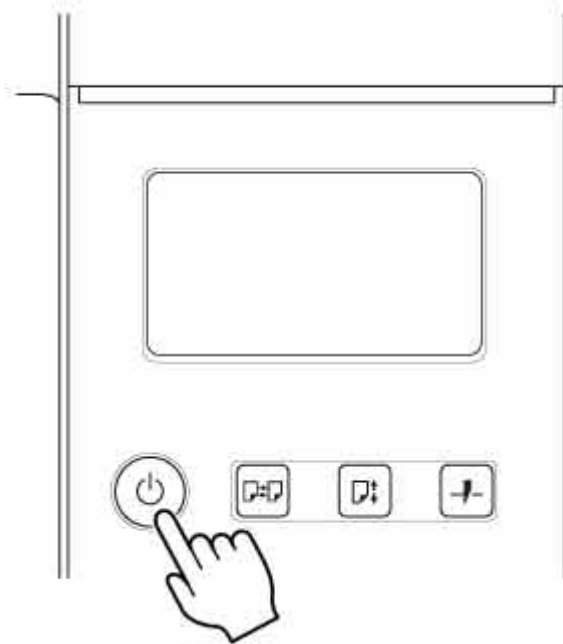

When startup is finished, the printer enters standby mode.

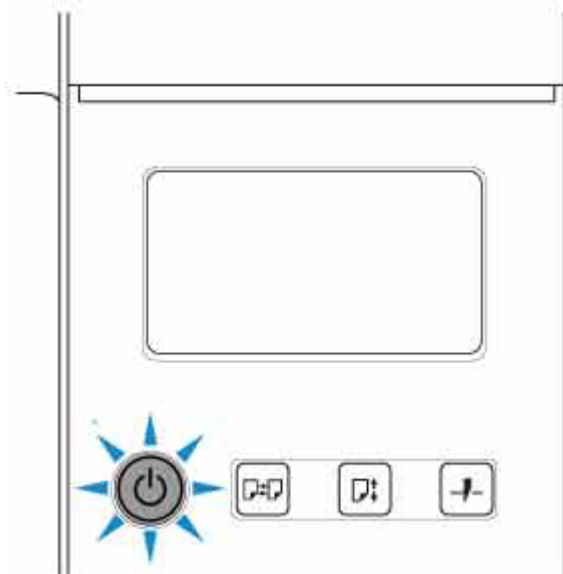

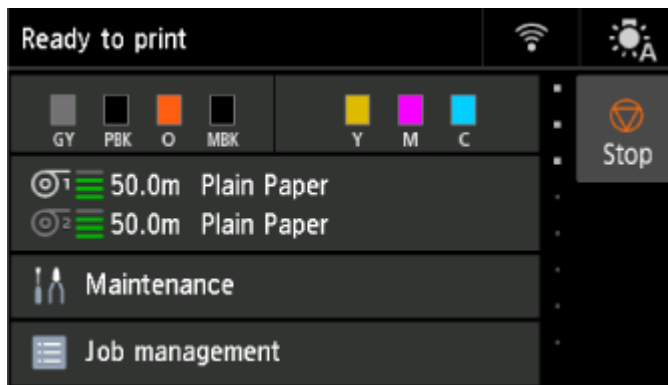

The printer will not enter standby mode in the following situations. Take action as necessary.

- **The top cover is open**
Close the top cover.
- **The ink tank cover is open**
Close the ink tank cover.
- **The print head is not installed**
➔ [Replacing the Print Head](#)
- **The ink tank is not installed**
➔ [Replacing Ink Tanks](#)
- **If "Error" is shown on the touch screen**
Check the message on the touch screen and take action as necessary.
- **The ON button and Status lamp do not light up, and nothing appears on the touch screen**
Check the connection at the plug and electrical outlet.

Turning the printer off

»»» Important

- Never disconnect the printer's power supply or unplug it during a print job. This may damage the printer.

1. Make sure no print jobs are in progress.

While the **Status** lamp is flashing, the printer is running. The color of the lamp indicates the following states.

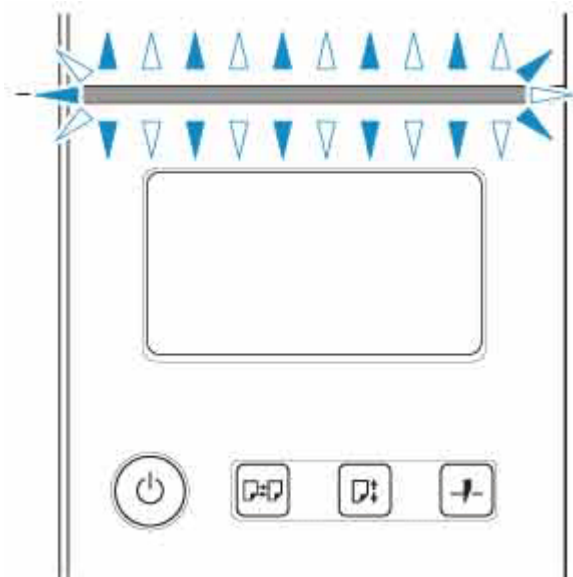

If the **Status** lamp is flashing orange, check the message on the touch screen and take action as necessary.

If the **Status** lamp is flashing white, the printer is printing, receiving data, etc. Turn off the power after the **Status** lamp turns off.

2. Hold down the **ON** button for more than a second.

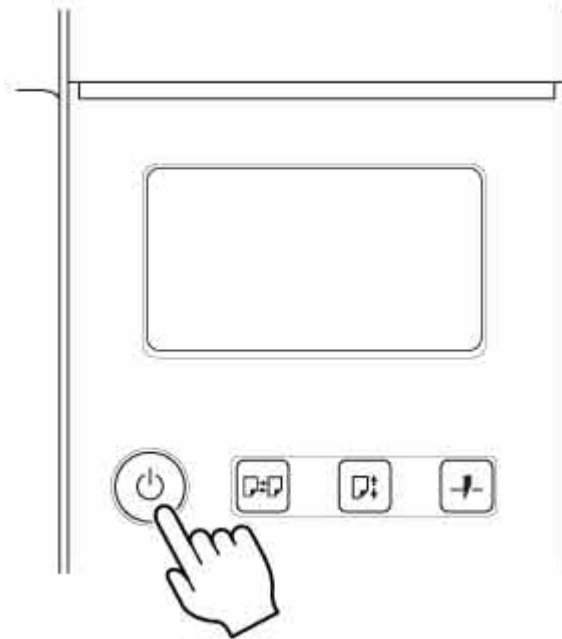

"Turning off... Please wait momentarily" appears on the touch screen, and the printer turns off.

Loading Rolls in the Printer

Follow these steps to load rolls in the printer.

When selecting **Enable** in **Roll paper auto feed**, the roll paper is fed automatically by simply loading it.

Important

- Always load rolls when the printer is on. If the printer is off when you load a roll, the paper may not be advanced correctly when you turn the printer on.
- Before loading a roll, confirm whether the inside of the top cover or the output guide is soiled. If these areas are dirty, we recommend cleaning them in advance.
 - ➔ [Cleaning Inside the Top Cover](#)
- If **Paper retention settings** is set to **Release**, the roll paper is not fed automatically.
- For details on the paper that can feed roll paper automatically, see "Paper Information List."

Note

- When using the roll unit, you can also load roll paper on the roll unit separately from the printer that is described here.
 - ➔ [Loading Roll Paper in the Roll Unit](#)
- When roll paper cannot be fed automatically, see "[Roll Paper Is not Switched Automatically.](#)"

1. Select the paper setting display area on Home screen.

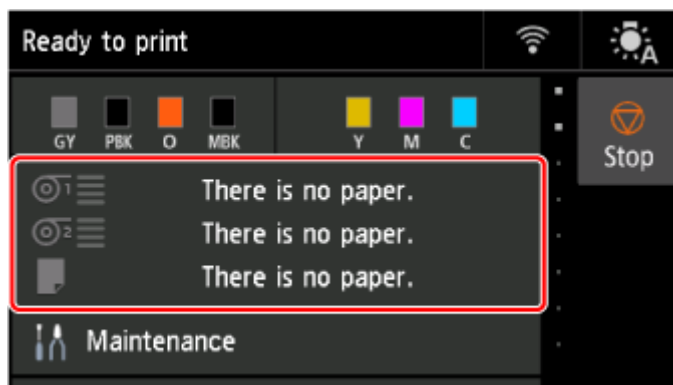

2. Select the **Roll paper 1** area.

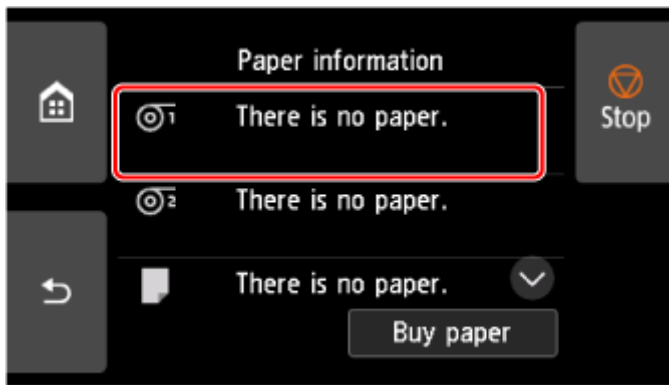

3. Select Load paper.

▶▶▶ Note

- If any paper has been advanced that will not be used, a message is shown requesting you to remove it. After following the instructions on the screen to remove the paper, go to the next step.

4. Open top cover and lift output guide.

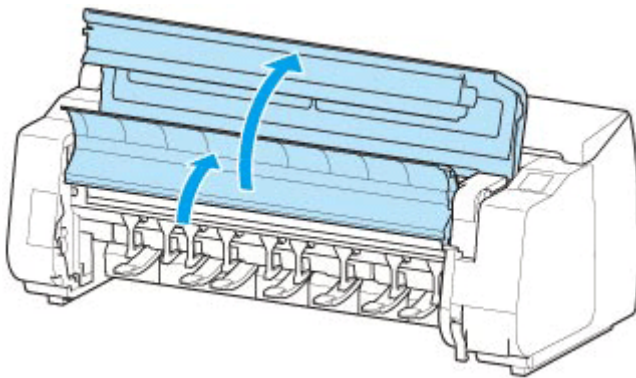

5. Hold flanges (A) so that holder stopper is on left, align roll holder shaft with roll holder slot left and right guide grooves (B), and load.

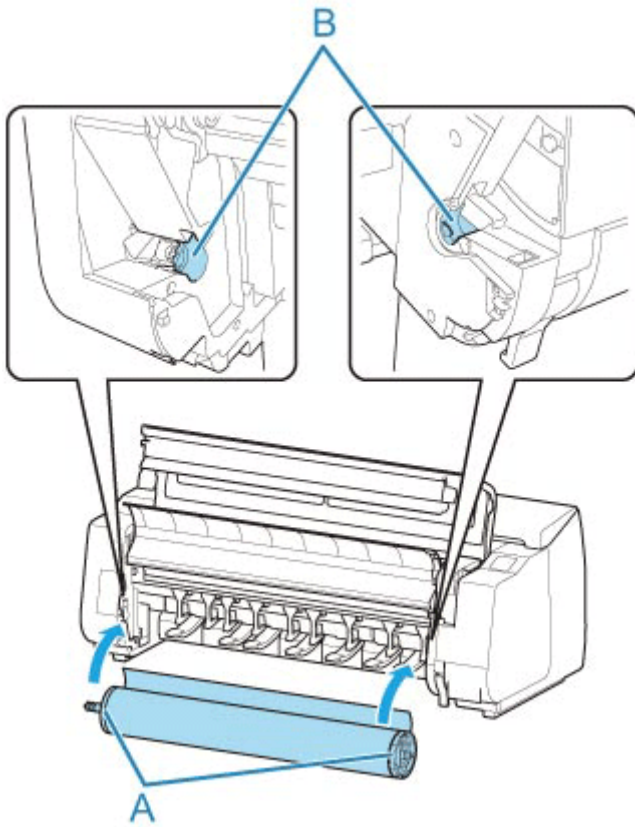

⚠ Caution

- Do not force the roll holder into the printer with the right and left ends reversed. This may damage the printer and roll holder.
- Do not release the flanges until the holder is loaded in the roll holder slot.
- Be careful not to pinch your fingers between the Roll Holder shaft and the guide grooves (B) when loading the roll paper.

»» Important

- If the leading edge of the roll paper is secured with tape or a paper band so that it will not unravel, remove the tape or paper band before loading the roll paper into the roll holder slot.
If you load the paper into the roll holder slot with the leading edge secured, only part of the roll paper is fed to the paper feed slot, resulting in damage to the roll paper.
- If the leading edge of the roll paper is cut crooked or folded, it may not be fed correctly. Cut the leading edge of the roll paper with scissors or the like and straighten it.
- Load the roll paper so that it is not loaded in the opposite direction.
- Make sure there is no slack in the roll paper, and then load it.
- Depending on the surrounding environment, the leading edge of roll paper is stuck because of static electricity or humidity so that the roll paper may not be able to be fed correctly. In this case, set **Roll paper auto feed to Disable**, and then feed the roll paper.
- If the roll paper is decentered, it may not be able to be fed correctly. In this case, set **Roll paper auto feed to Disable**, and then feed the roll paper.

- When **Roll paper auto feed** is **Enable** and if you attach the roll holder without the roll paper loaded on the roll holder, **Preparing to feed the paper...** appears on the operation panel. In this case, press the **Stop** button on the operation panel to cancel feeding.

▶▶▶ Note

- For the procedure for attaching the roll paper to the Roll Holder, see "[Loading Rolls on the Roll Holder.](#)"

- **When selecting Enable in Roll paper auto feed.**

Go to step 6.

- **When selecting Disable in Roll paper auto feed.**

Pull out roll paper evenly, insert leading edge between roll paper and arrows (A) directly beneath it, and feed roll paper until you hear a sound.

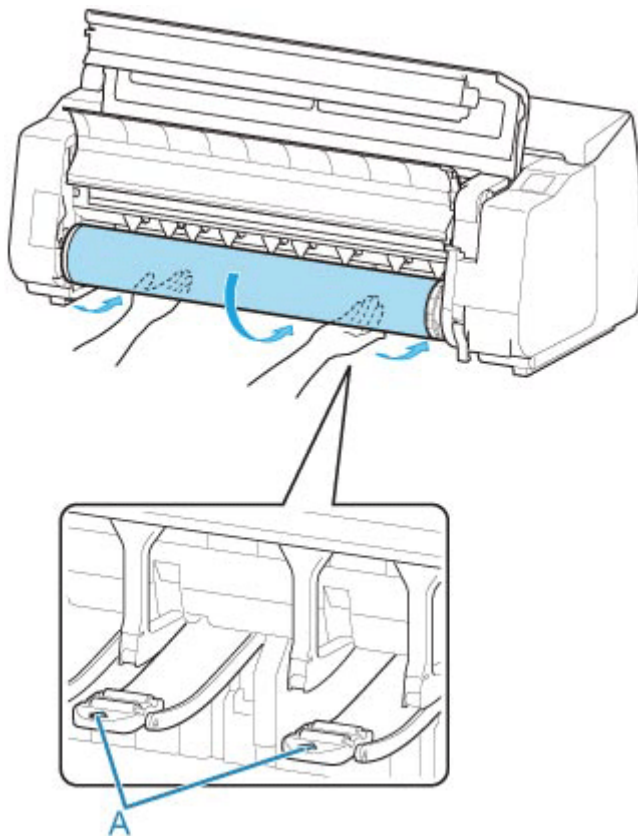

▶▶▶ Important

- If the roll paper has become unwound, remove the slack before loading the roll paper.
- When feeding the leading edge of the roll paper, make sure the entire width of the roll paper is separating and feeding from the roll. If the roll paper is fed with some of the roll paper still stuck to the roll, the roll paper will be damaged.
- Be careful not to soil the printing surface of roll paper as you insert it in the slot. This may affect the printing quality. We recommend wearing clean cloth gloves when handling rolls to protect the printing surface.

- If the paper is wrinkled or warped, straighten it out before loading it.
- Load the roll so that there is no gap between the right edge of the paper and the Roll Holder.

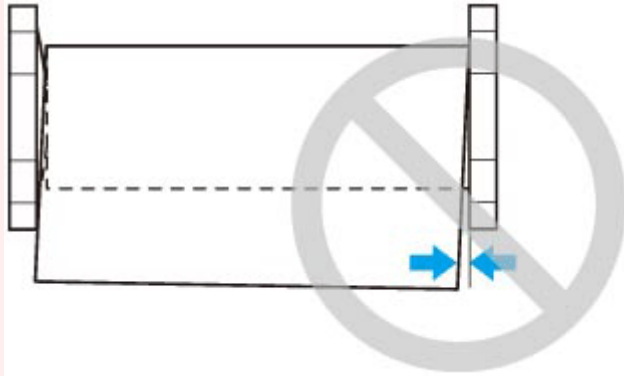

- Depending on the paper, the roll paper may be scratched when being fed and not feed well. In this case, you must feed the paper manually after setting **Paper retention settings** to **Release** on the touch screen. Lift the release lever, advance the roll paper until its leading edge appears on platen, lower the release lever, and then proceed to the next step. However, if **Paper retention settings** is set to **Release**, automatic switching of the upper and lower rolls is not possible.

3. Lower output guide.

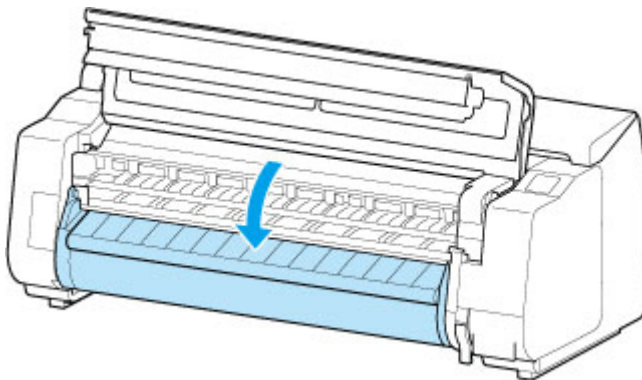

4. Close top cover.

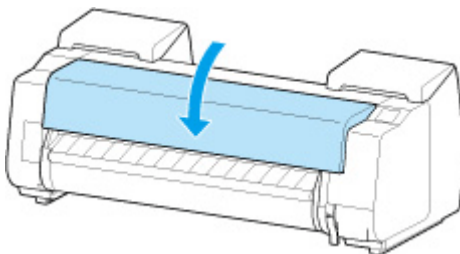

- **When selecting Enable in Roll paper auto feed.**
The roll paper is fed.
- **When selecting Disable in Roll paper auto feed.**
Select **Start feeding**, and then the roll paper is fed.

5. After paper feeding has started, do the following operations based on the **Manage remaining roll amount** setting and the barcode printed on the roll paper

➡ [Keeping Track of the Amount of Roll Paper Left](#)

- **When selecting Disable or Auto estimate in Manage remaining roll amount.**

- **When selecting Manual or Auto with confirmation in Media type selection method.**

- A menu for selecting the media type appears on the touch screen. Operate the touch screen and select the media type to be used.

- **When selecting Auto detect in Media type selection method.**

- You'll see candidate for the media type you've estimated to the touch screen. After 5 seconds, the paper type of the first item is selected. If you choose a different candidate, you can use the touch screen to select the type of paper you want.

- **When selecting Use current media type in Media type selection method.**

- A menu for selecting the media type appears on the touch screen. After 5 seconds, the media type will be selected with the fixed media kind.

- **When selecting Barcodes in Manage remaining roll amount and if the barcode is printed.**

- The type and amount of paper left is automatically detected based on the barcode printed on the roll. There is no need to specify the type and length of the paper.

- **When selecting Barcodes in Manage remaining roll amount and if the barcode is not printed.**

- **When selecting Manual in Media type selection method.**

- A menu for selection of the media type and length is shown on the touch screen. Operate the touch screen, select the media type to be used, and enter its length.

- **When selecting Auto with confirmation in Media type selection method.**

- A menu for selecting the estimated media type candidates and the paper length. Interact with the touch screen, select the media type you want to use, and enter the length.

- **When selecting Auto detect in Media type selection method.**

- A menu for selecting the estimated media type candidates and the paper length. After 5 seconds, the paper type of the first item is selected. If you choose a different candidate, you can use the touch screen to select the type of paper you want.

- **When selecting Use current media type in Media type selection method.**

- A menu for selecting the media type and the paper length appears on the touch screen. After 5 seconds, the media type will be selected with the fixed paper kind.

»»» Important

- If the leading edge of the roll paper is folded or dirty, cut the leading edge of the roll paper.

- ➡ [Cutting Roll Paper](#)

»» Note

- If you have selected **Auto with confirmation** or **Auto detect** in the **Media type selection method** and you are using the barcode to manage the remaining roll paper, the barcode is read first. If it fails to read the barcode, it will detect the media type from the estimated result and display the candidate.
- For details on media types that you can select, see "Paper Information List."
- The width of the roll paper is automatically detected by the printer when the paper is loaded.

When using roll paper with a user-defined size width, the detected width length and the set width length must exactly match, so even if the correct roll paper is loaded, detection may fail.

In this case, you can improve it by setting the roll paper width you want to use in **Add priority roll paper width**.

➡ [Add priority roll paper width](#)

Loading Sheets in the Printer

Follow these steps to load sheets in the printer.

Important

- Paper that is wrinkled or warped may jam. If necessary, straighten the paper and reload it.
- Load the paper straight. Loading paper askew will cause an error.
➔ [1317](#)
- If you are not using the stand, make sure there is no object under the printer. If there is any object under the printer, it may cause damage of the paper or jamming.

Note

- Before loading cut sheets, check whether or not the inside of the top cover or the output guide is soiled. If these areas are dirty, we recommend cleaning them in advance.
➔ [Cleaning Inside the Top Cover](#)
- Store unused paper in the original package, away from high temperature, humidity, and direct sunlight.

1. Select the paper setting display area on Home screen.

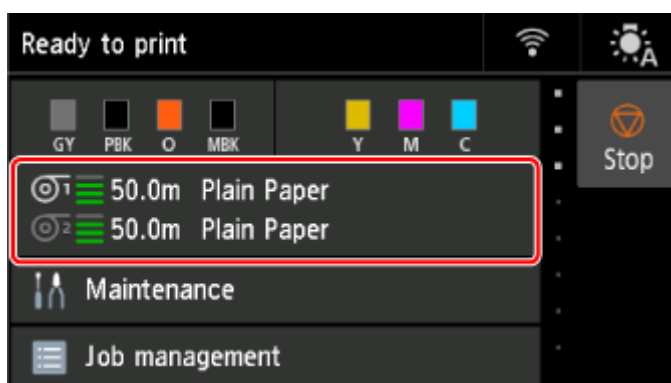

Note

- If a print job has been received in advance, follow the instructions on the screen and select **Load paper**.

2. Select the **Manual** area.

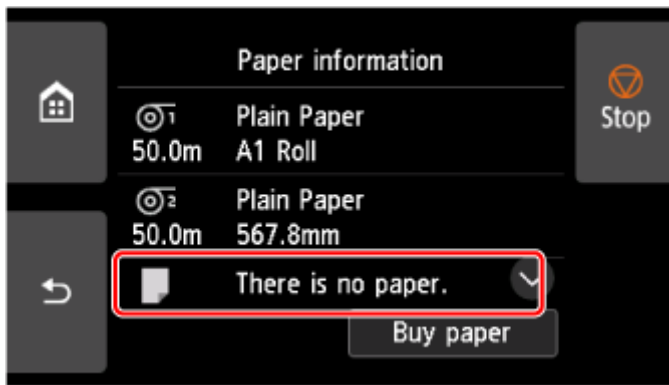

3. Select **Load paper**.

4. Open top cover and lift release lever.

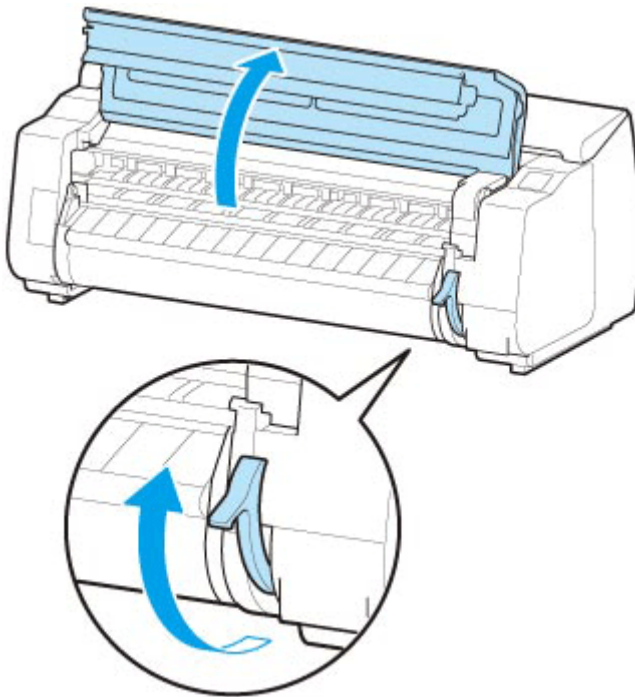

»»» Important

- Do not touch Linear Scale (A), carriage shaft (B), or Ink Tube Stabilizer (C). Touching these parts may damage them.

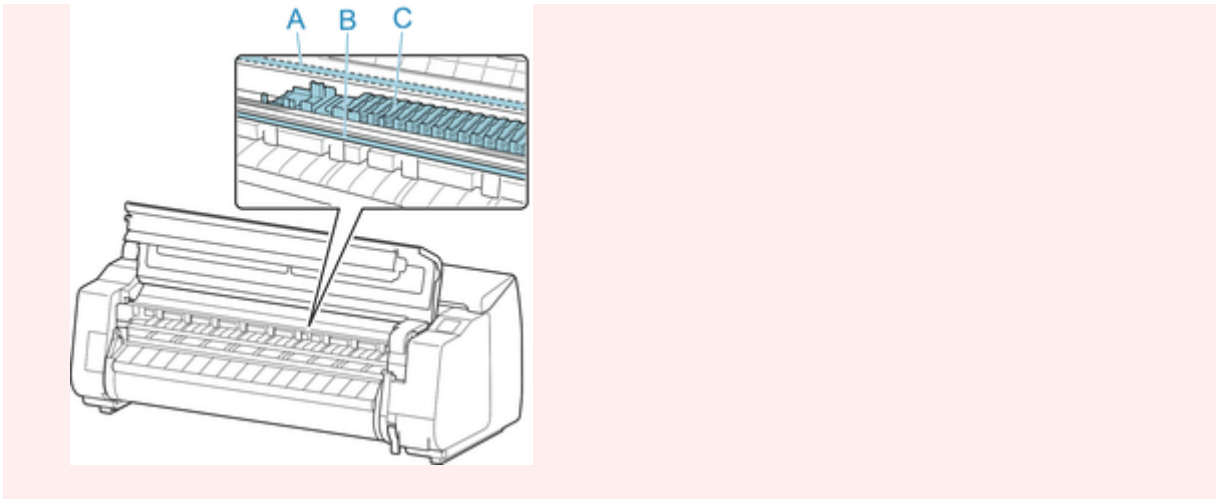

5. Insert the cut paper in portrait orientation, with the print side up, between the platen (D) and the paper retainer (E).

When the cut paper is inserted, it is automatically adsorbed onto platen surface.

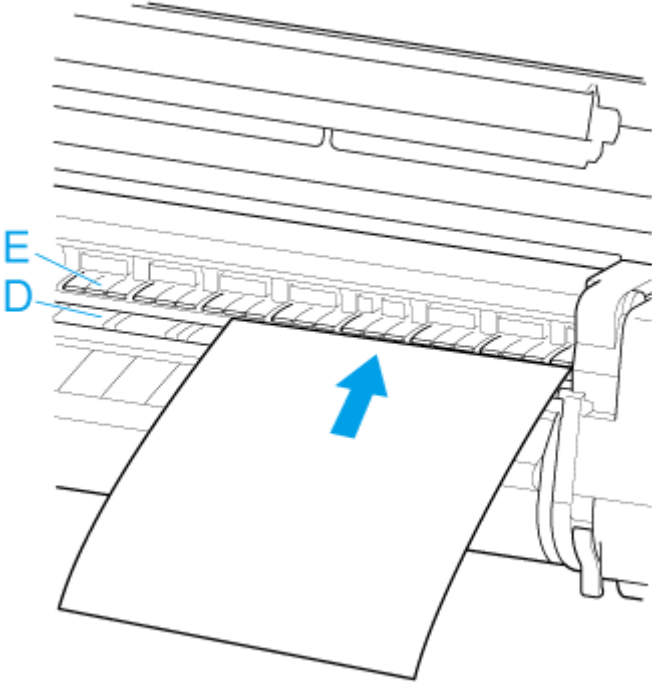

6. Align the paper with the paper alignment line (F) on the right side.

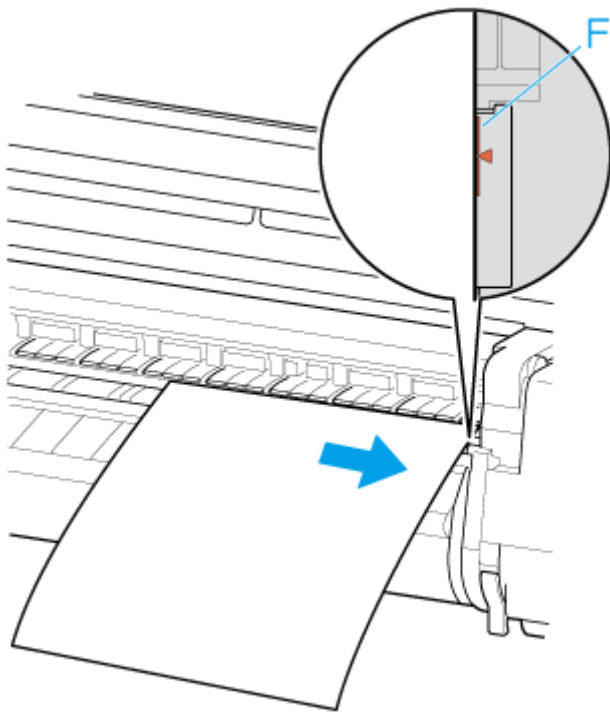

7. Align the back edge of the inserted paper with the front edge of the back paper alignment line (G).

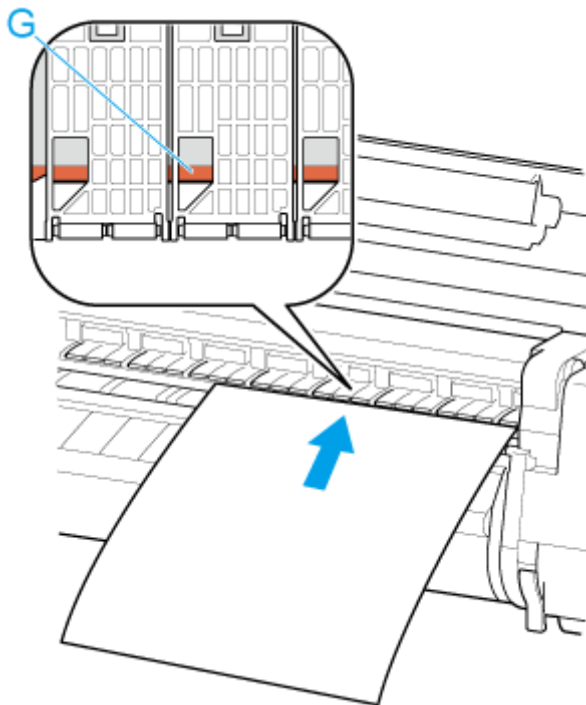

»» Important

- Load the sheet so that it is parallel to the right paper alignment line (F). Loading paper askew will cause an error.
- Warped paper may rub against the print head. Straighten paper if it is warped before loading.

▶▶▶ Note

- You can also align the cut sheet based on its near edge. In this case, load the cut sheet aligning its near edge with marks (H) on the platen and the right edge with the right-side paper alignment line (F).

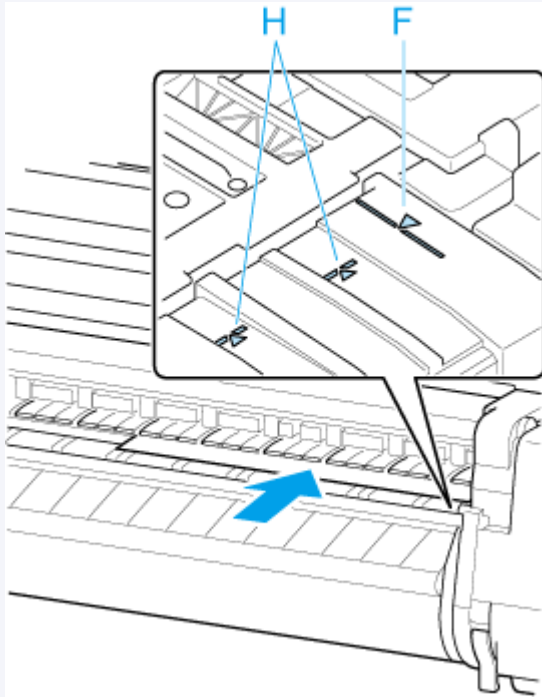

- You can adjust the vacuum strength holding the paper against the platen when the release lever is up. If it is difficult to load the paper, tap **Suction** on the touch screen and adjust the vacuum strength. You can adjust the vacuum strength to 5 levels.

However, even if you increase the suction, it may not be sufficient to hold some types of paper against the platen well. In this case, use your hand to load the paper.

- Sheets are held in place by suction through holes on the platen. Although the suction may produce a noise when paper is loaded in some positions, it does not indicate a problem. If the noise is distracting, try moving the paper over slightly to the left or right (up to 0.04 inch (1 mm)) while keeping it parallel to the paper alignment line.
- The suction remains on for about 30 seconds during loading. If you cannot finish loading a sheet during this time, pull the sheet away and reinsert it to start the suction again.

8. Lower release lever and close top cover.

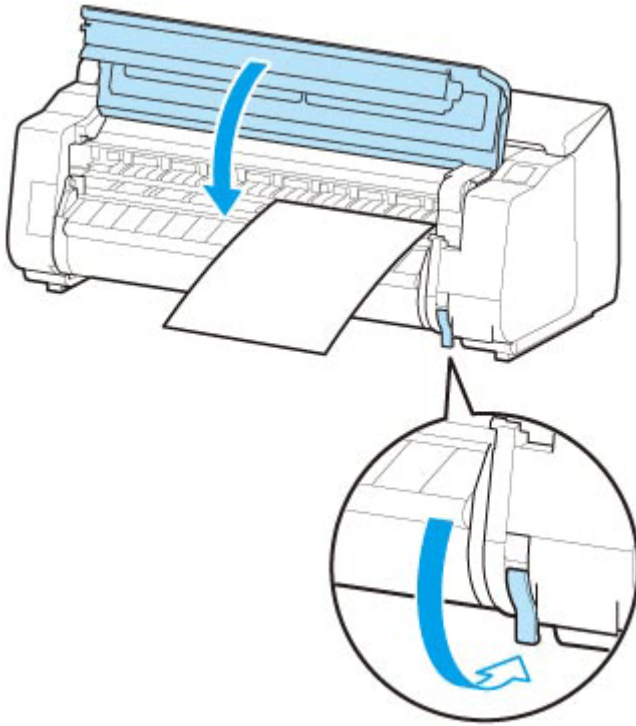

▶▶▶ **Note**

- If a print job has been received in advance, follow the touch screen to start printing after loading the paper.

9. Select the type of loaded paper and select **OK.**

Paper feeding will start.

▶▶▶ **Note**

- For details on media types that you can select, see "Paper Information List."

Using the Basket on the Printer Stand

By changing the following four items for the basket, you can use the basket in various ways to suit your application.

- Length of basket arm
- Tilt of basket arm
- Attachment position of basket
- Length of basket

This section describes how to change the basket.

For specific examples of basket use, see "[Example Basket Configurations.](#)"

►► Important

- When changing the position of the basket, first return the basket to a unwound state while pressing the basket rewind button on the right end of the basket rod (tag side), and then make the change.
- If the basket rod (tag side) has come off the basket arm, attach it by inserting the projections on both ends of the basket rod (tag side) into oval holes on the tip of the basket arm.
- When moving the printer, remove the basket.
- Do not apply excessive force to the basket. Doing so may damage the basket.
- If the cloth part of the basket becomes dirty, wipe off the dirt without washing. Washing it may affect the performance of the basket.

Changing Length of basket arm

You can change the length of the basket arm in two steps.

To lengthen, expand the left/right basket arm in the direction of the arrow.

To shorten, contract the left/right basket arm in the opposite direction of the arrow.

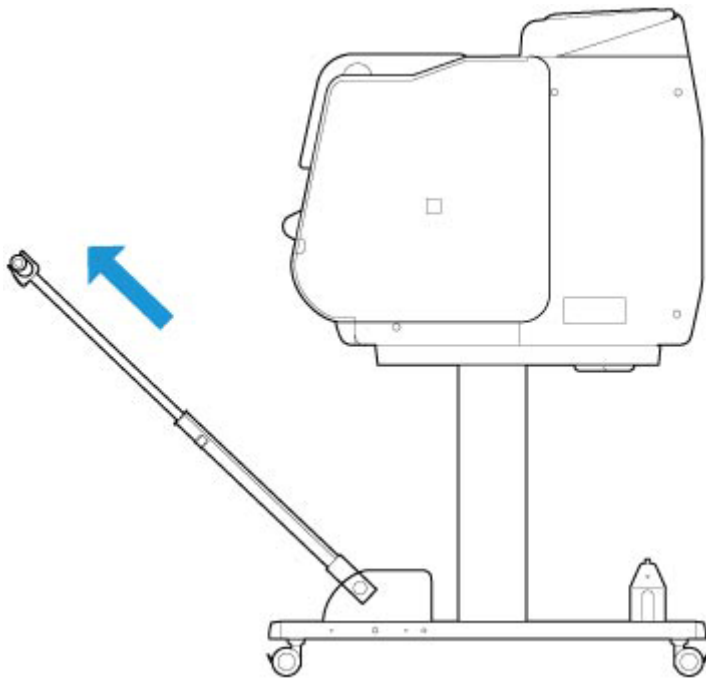

»» Important

- When lengthening the basket arm, first return the basket to an unwound state while pressing the basket rewind button on the right edge of the basket rod (tag side), and then make the change.

Changing Tilt of basket arm

You can change the tilt of the basket arm in three steps.

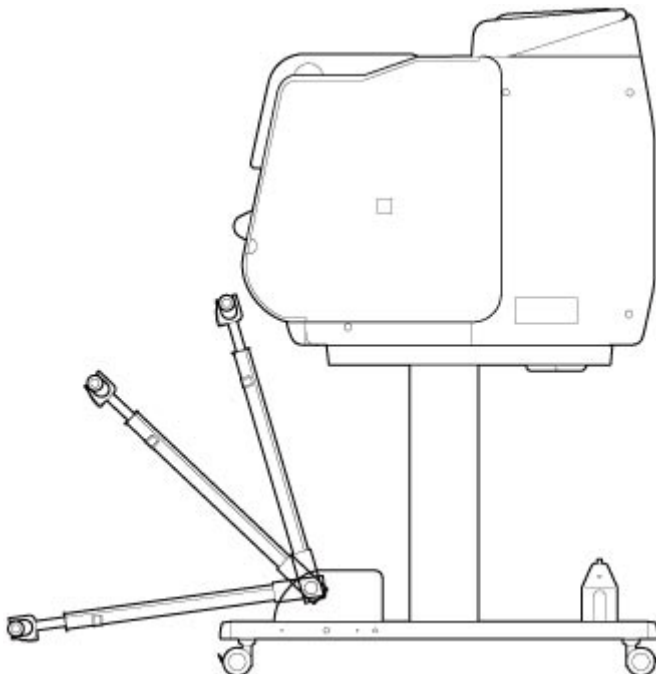

When securing the basket arm, attach the basket locking support to the basket arms (A) on both sides.

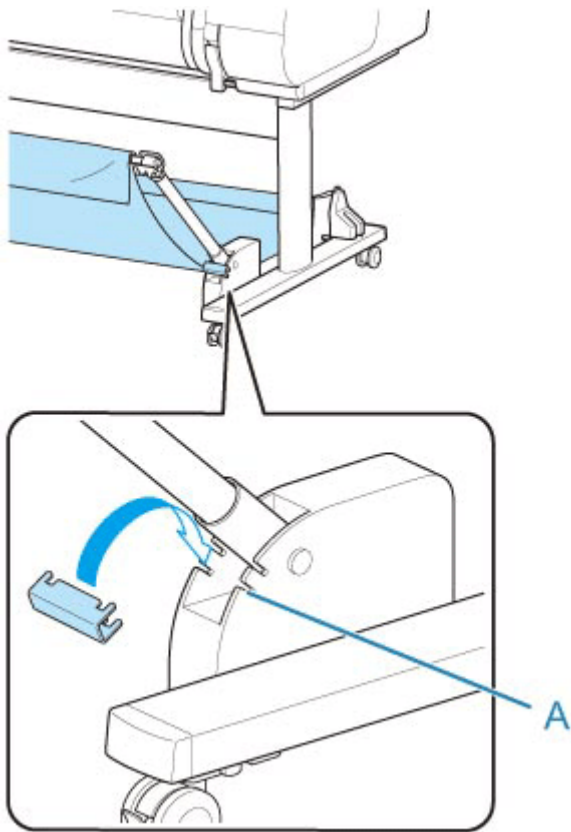

►► Important

- If you are changing the angle of the basket arm, make sure the thick part of the basket arm is pulled out as far as possible.
 - When changing the angle of the basket arm, hold the thick part of the left/right basket arm, and adjust them.
 - While using the basket locking support, do not apply excessive force to the orientation in which you lower the basket arm. Doing so may damage the basket.
 - While using the basket locking support, you cannot use "[Printing on Large-Format or Easily Damaged Paper \(Position 3\)](#)." When using this position, detach the basket locking support.
 - While using the basket locking support, you cannot store the basket. When you store the basket, detach the basket locking support.
- ➔ [Storing the Basket on the Printer Stand](#)

Changing Attachment Position of basket

You can attach the basket rod (cord side) to the stand's rod holder or the front of the printer.

To attach, hang both sides of the basket rod (cord side) on the paired attachment locations shown in the illustration.

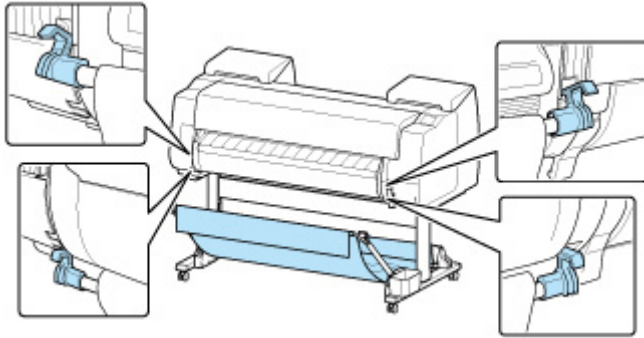
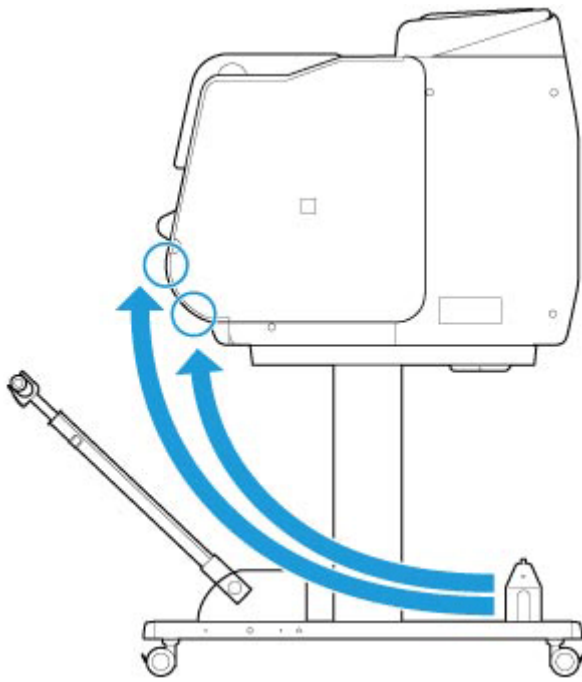

►►► Important

- When attaching the basket rod (cord side) to the front of the printer, make sure both ends of the rod (A) are securely hooked onto the attachment parts.

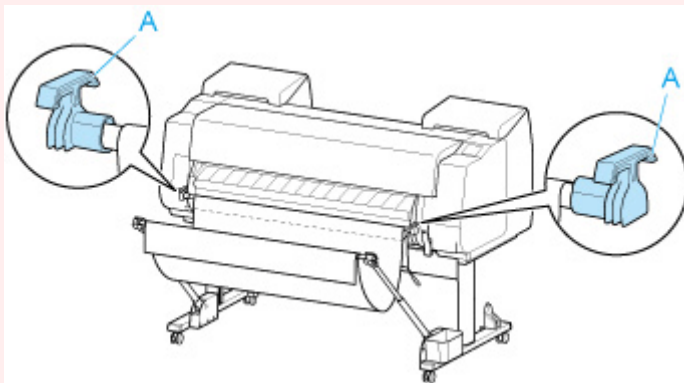

Changing Length of basket

You can adjust the basket length by rotating the basket rod (tag side).

To shorten, rotate the basket rod (tag side) in the direction of the arrow to wind the basket.

To lengthen, rotate the basket rod (tag side) in the opposite direction of the arrow while pressing the basket rewind button (A) on the right end of the basket rod (tag side). You can return the wound basket to its original position.

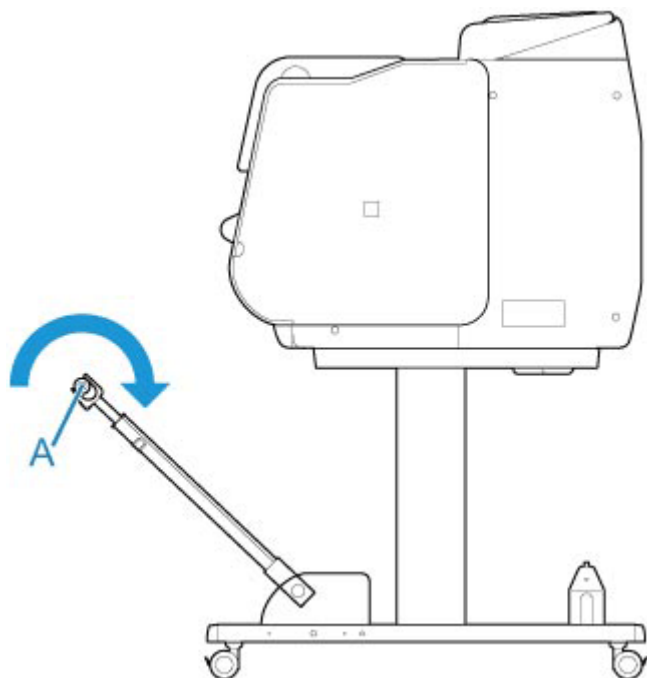

Example Basket Configurations

Various positions are possible for the basket that collects the printed materials.

In this section, we present the following five positions as examples of using the basket. Switch the position of the basket to suit to the media type and the print job.

- ➔ [Using Without roll unit \(Position 1\)](#)
- ➔ [Using With roll unit \(Position 2\)](#)
- ➔ [Printing on Large-Format or Easily Damaged Paper \(Position 3\)](#)
- ➔ [Stacking Printed Materials \(Position 4\)](#)
- ➔ [Moving Printed Materials to Next Work Area Immediately \(Position 5\)](#)

For instructions on switching the basket position, see "[Using the Basket on the Printer Stand.](#)"

▶▶▶ Important

- If replacing the roll paper or using the roll unit as a take-up device, you must store the basket.
 - ➔ [Storing the Basket on the Printer Stand](#)
- If the printed materials collected are damaged or folded, select **Eject cut** in **Cutting mode** or use the basket in a different position.
 - ➔ [Specifying the Cutting Method for Rolls](#)

Using Without roll unit (Position 1)

You can use the basket in the following positions when not using the roll unit.

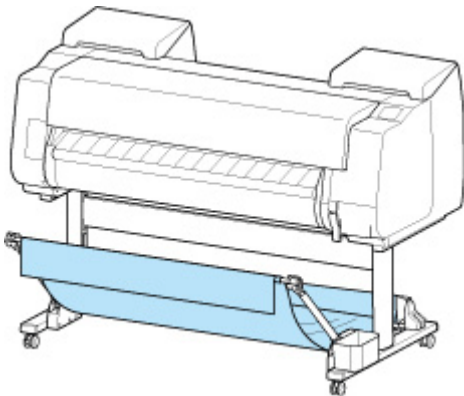

▶▶▶ Important

- The number of sheets that can be collected in the basket is one. If printing multiple pages, print after removing each sheet.
- If using the roll unit as a feed device, we recommend using it as described in "[Using With roll unit \(Position 2\)](#)".
- If using the roll unit and using the Position 1 basket, the printed materials may come in contact with the roll unit depending on the paper, resulting in damage.

- If using the roll unit as a feed device and using the Position 1 basket, the ejected roll paper's cut end enters the roll unit and may cause a paper jam or affect the print quality when set to **Borderless Printing** or **Trim edge first** when loading the paper.
- Roll paper up to 62.0 inches (1,575 mm) in length can be collected in the basket. If printing on longer roll paper, use as described in "[Printing on Large-Format or Easily Damaged Paper \(Position 3\)](#)" or use with the roll unit as the take-up device.

Using With roll unit (Position 2)

You can use the basket in the following positions when using the roll unit as a feed device.

This position is useful also when rewinding printed roll paper by hand.

Move the basket rod (cord side) to the upper of the two pairs of attachment locations on the front of the printer, and extend the basket arm as far as possible at the angle shown to achieve this position.

You can adjust the basket length so that it is easy to use.

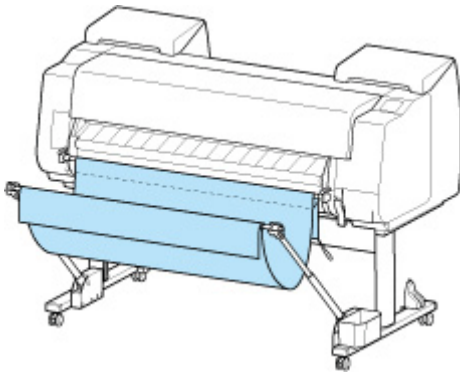

►► Important

- You can place up to approximately 4.41 lbs (2 kg) of printed materials in the basket. If the weight of the printed materials is greater than that, the basket may fall over.

Printing on Large-Format or Easily Damaged Paper (Position 3)

If printing on large-format or easily damaged paper, you can use the basket in the following position.

Move the basket rod (cord side) to the upper of the two pairs of attachment locations on the front of the printer, extend the basket arm as far as possible, and lower it to the angle shown. Next, adjust the length so that the basket is pulled into this position.

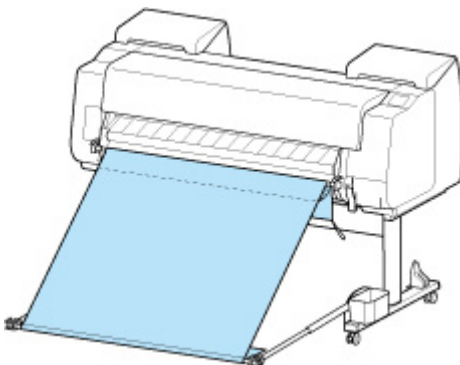

»» Important

- Always select **Eject cut** in **Cutting mode** when used in this position. If you select **Automatic cut**, the printed materials may be damaged.
 - ➔ [Specifying the Cutting Method for Rolls](#)
- Be extra careful when using paper that tends to curl or is damaged easily in this position.
- With some types of paper, the leading edge may curl or bend during ejection. In this case, straighten out the paper. Printed documents may be damaged if the paper is curled or bent.
- Depending on the paper, the paper may be caught between the output guide and the basket when being ejected. In this case, fix the paper that is caught. If the paper is caught, printed documents may be damaged.

Stacking Printed Materials (Position 4)

You can use the basket in following positions when you want to stack printed materials.

Move the basket rod (cord side) to the lower of the two pairs of attachment locations on the front of the printer, extend the basket arm as far as possible in the angle shown. Next, adjust the length so that the basket is pulled into this position.

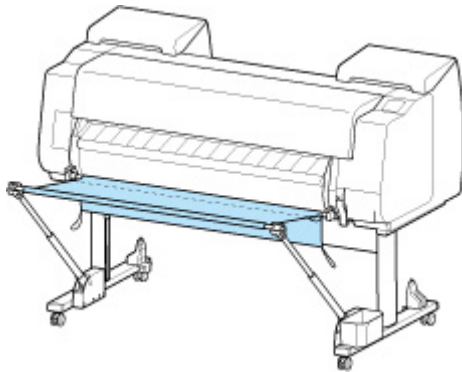

»» Important

- In the following cases, use as described in "[Using Without roll unit \(Position 1\)](#)" or "[Using With roll unit \(Position 2\)](#)". If printing multiple pages in these positions, print after removing each sheet.
 - Printed materials other than A2 portrait
 - Paper curls an extreme amount due to paper characteristics and printing environment
 - If there is not much paper remaining on the roll, and the paper curls an extreme amount

Moving Printed Materials to Next Work Area Immediately (Position 5)

You can use the basket in the following position when moving the printed materials to the next work area immediately.

Move the basket rod (cord side) to the upper of the two pairs of attachment locations on the front of the printer, extend the basket arm as far as possible in the angle shown. Next, adjust the length so that the basket is pulled into this position.

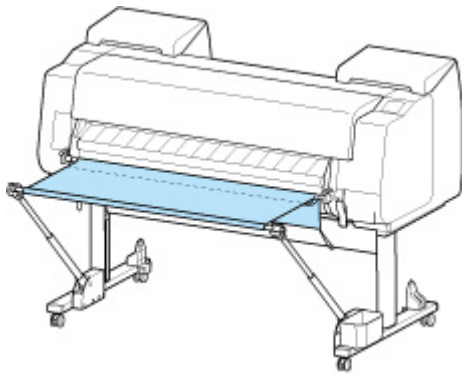

►► Important

- Be extra careful when using paper that tends to curl or is damaged easily in this position.
- With some types of paper, the leading edge may curl or bend during ejection. In this case, straighten out the paper. Printed documents may be damaged if the paper is curled or bent.
- Depending on the paper, the paper may be caught between the output guide and the basket when being ejected. In this case, fix the paper that is caught. If the paper is caught, printed documents may be damaged.

Storing the Basket on the Printer Stand

Store the basket in the following two positions when not in use. Select the position to suit the circumstances.

- ➔ [If Changing Roll Paper or Using roll unit as Take-up Device](#)
- ➔ [Using Without basket \(Only When roll unit Is Not Used\)](#)

If Changing Roll Paper or Using roll unit as Take-up Device

If replacing the roll paper or using the roll unit as a take-up device, store the basket.

You can store the basket, by attaching the basket rod (cord side) to the rod holder, lowering the basket arm until level, and then pushing as far back as possible.

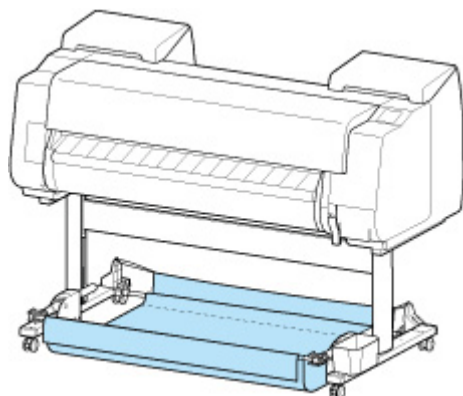

►► Important

- If changing the basket position, first release and rewind the basket. If it is not released and rewound, the change may not be performed smoothly, or the basket may be damaged.
- If you are changing the angle of the basket arm, make sure the thick part of the basket arm is pulled out as far as possible.
- If the basket rod (tag side) has come off the basket arm, attach it by inserting the projections on both ends of the basket rod (tag side) into oval holes on the tip of the basket arm.
- Do not apply excessive force to the basket. Doing so may damage the basket.

Using Without basket (Only When roll unit Is Not Used)

If you are not using the roll unit, you can easily store the basket by holding the thick parts of the left/right basket arm in "[Using Without roll unit \(Position 1\)](#)", and moving them in the direction of the arrow.

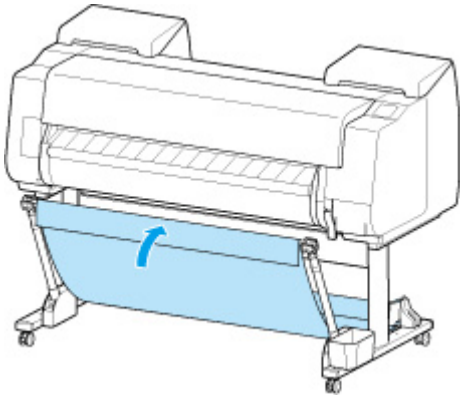

Using the Roll Unit for Media Take-Up

- **Switching Roll Unit Modes**
- **Using the Roll Unit In Take-Up Mode**
- **Removing Printed Paper from the Roll Unit**

Switching Roll Unit Modes

Before using the roll unit, follow these steps to select the mode you want to use.

»» Important

- After switching the roll unit function, you must use a separate computer to apply the roll unit settings to the printer driver.
 - ➔ Reflect Roll Unit Settings in the Printer Driver (Windows)
 - ➔ [Reflect Roll Unit Settings in the Printer Driver](#) (macOS)
- If you change the roll unit from a take-up device to a feed device, first cut the paper that has been taken up.

Using as take-up device

1. Select the paper setting display area on Home screen.

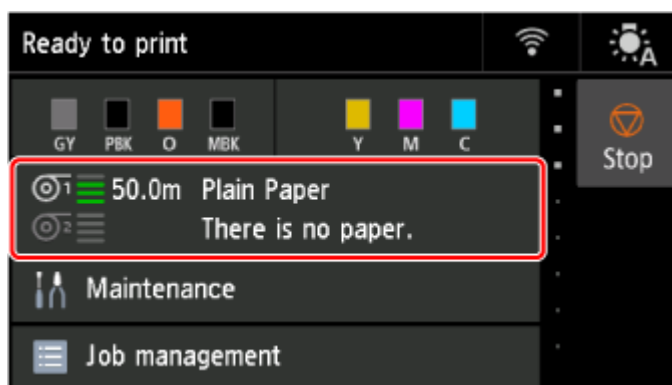

2. Select the **Roll paper 2** area.

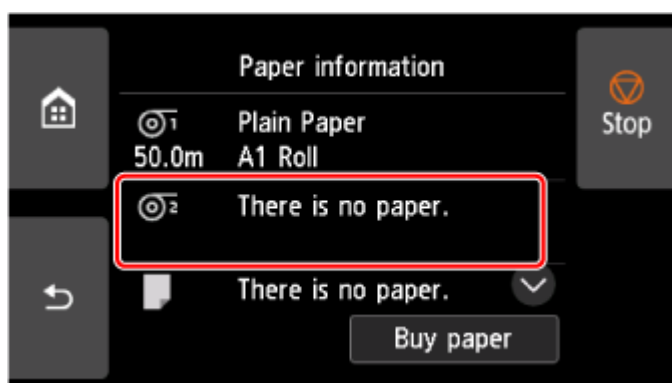

3. Select **Roll unit use settings**.
4. Check the contents of the message and select **ON**.
5. Select paper cutting settings when using take-up mode.

▶▶▶ Note

- If you selected **Do not cut**, the roll paper will not be cut after printing regardless of the **Cutting mode** setting on the printer. Select this option when you want to print multiple pages consecutively without cutting.
- If you selected **Use the cutting mode setting**, cutting for each page will be performed according to the **Cutting mode** setting on the printer.
 - ➔ [Specifying the Cutting Method for Rolls](#)
- If you select **Use the cutting mode setting**, and **Automatic cut** is set in the **Cutting mode** settings on the printer, we recommend setting **Wind up after cutting** to **Enable**. When set to **Disable**, a printed document that has been taken up is cut automatically without being pressed, resulting in fraying.
- If roll paper is loaded from the roll unit to the printer, a screen confirming whether or not to remove the roll paper appears. If you select **Yes**, the roll paper is positioned so that it can be removed and the roll unit changes to a take-up device.

6. Check the contents of the message and select **Yes** or **No**.

If you select **Yes**, the steps for loading the paper on the roll unit appear on the touch screen.

If you select **No**, the operation ends here. Load the paper on the roll unit when printing. However, in this case, you must load the paper while printing is progressing, so instructions will not appear on the touch screen.

For details on loading paper on the roll unit set as a take-up device, see "[Using the Roll Unit In Take-Up Mode](#)."

▶▶▶ Note

- If you select **Yes**, a margin of approximately 23.7 inches (600 mm) is generated at the leading edge because the roll paper advances to the roll unit before printing.

Using as feed device

1. Select the paper setting display area on Home screen.

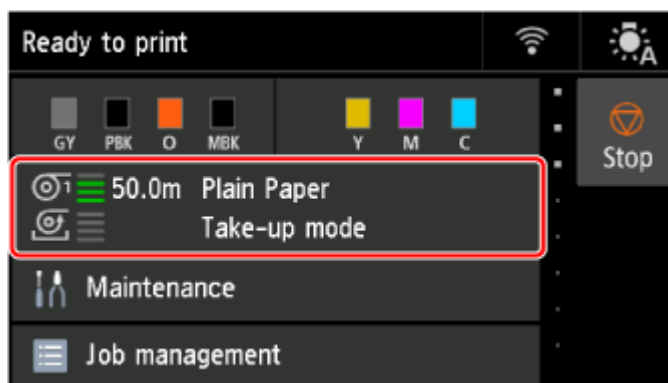

2. Select the **Take-up mode** area.

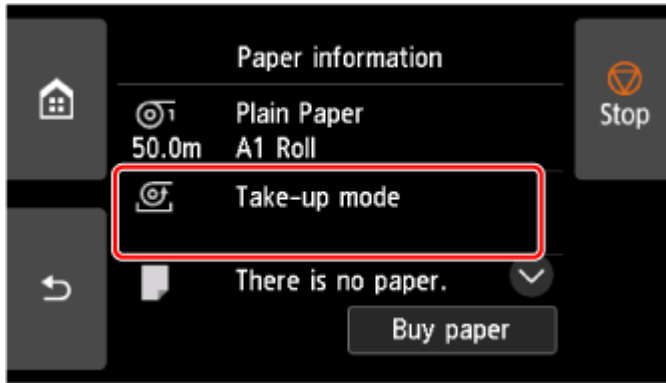

3. Select **Roll unit use settings**.
4. Check the contents of the message and select **ON**.

▶▶▶ Note

- If you change the mode without cutting the roll paper with the printer's cutter, a screen confirming whether or not the paper taken up has been cut appears after you select **ON**. If the paper has not been cut, select **No** and cut the paper that has been taken up first.

Using the Roll Unit In Take-Up Mode

►► Important

- For details on the roll paper compatible with winding, see "Paper Information List."
- Before loading the roll paper to be taken up on the roll unit, set the roll unit mode to take-up device on the printer touch screen.
 - ➔ [Switching Roll Unit Modes](#)
- If the roll holder is installed on the roll unit, first remove the roll holder from the roll unit, and then remove the roll paper loaded on the roll holder.
 - ➔ [Removing Roll Paper from the Roll Unit](#)
- Paper winding is possible until the outer diameter of the wound paper is the same as the outer diameter of the holder stopper.

1. Store basket.

- ➔ [Storing the Basket on the Printer Stand](#)

- #### 2. Rotate the holder stopper lever (A) towards to release the lock, and while holding the end plate (B), remove the holder stopper from the roll holder.

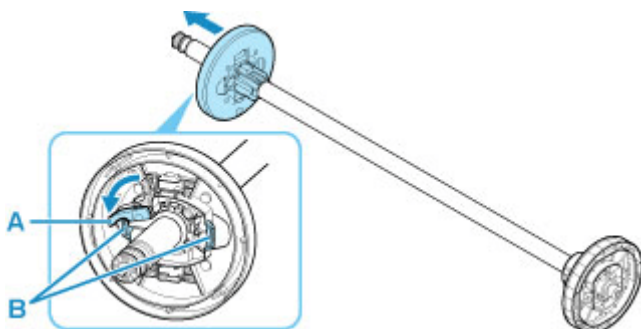

- #### 3. If taking up roll paper whose paper core has an inner diameter of 3 inches (76.2 mm), insert 3-Inch Paper Core Attachment in roll holder and holder stopper.

Align the 3-Inch Paper Core Attachment tabs (A) with the holes on the roll holder or holder stopper (B) and insert firmly.

- roll holder Side

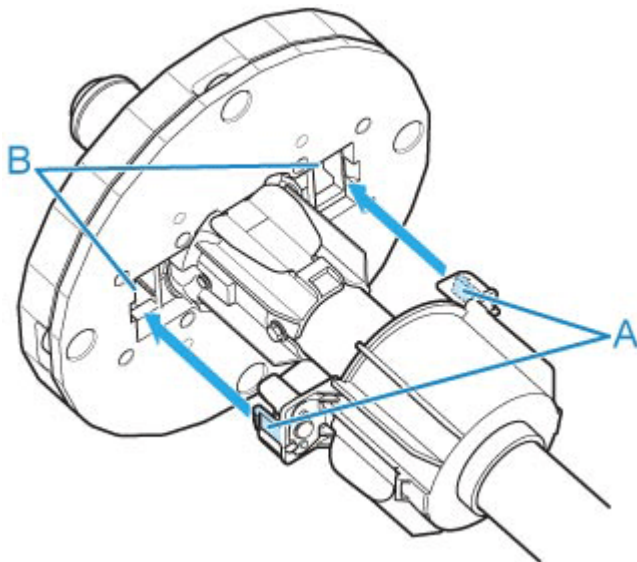

- holder stopper Side

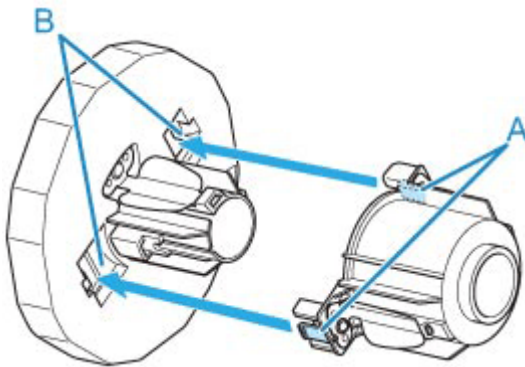

4. Insert paper core, which is for winding roll paper, into roll holder.

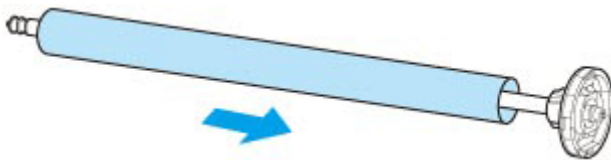

▶▶▶ Important

- We recommend using a paper core that is wider than the paper to be wound when winding paper. If you use a narrower paper core, use with a gap between the holder stopper and the paper.
- Always use a paper core for winding that is the same thickness or is thicker than the roll paper's paper core. If you use a paper core that is thinner, it may affect take up.

5. Insert holder stopper from left into roll holder, and then while holding the end plate (B), push firmly until holder stopper flange (A) touches paper core. Lock the holder stopper lever (C) by rotating it towards .

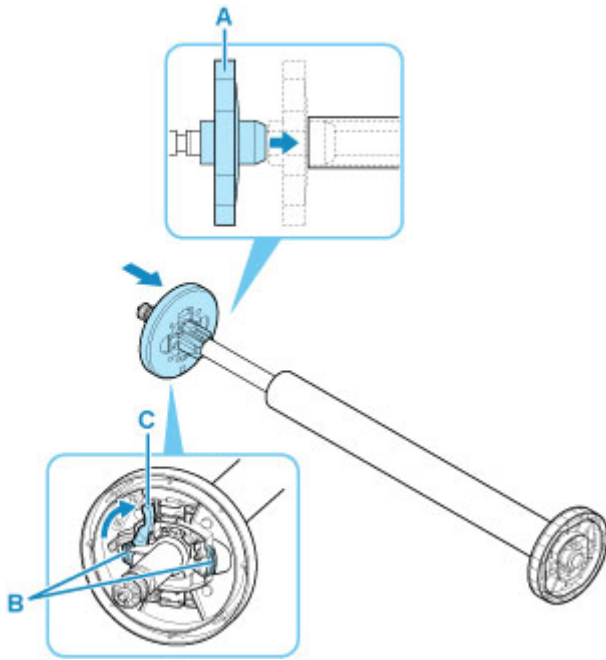

6. Change **Roll Holder Lock** switch on roll unit to release position.

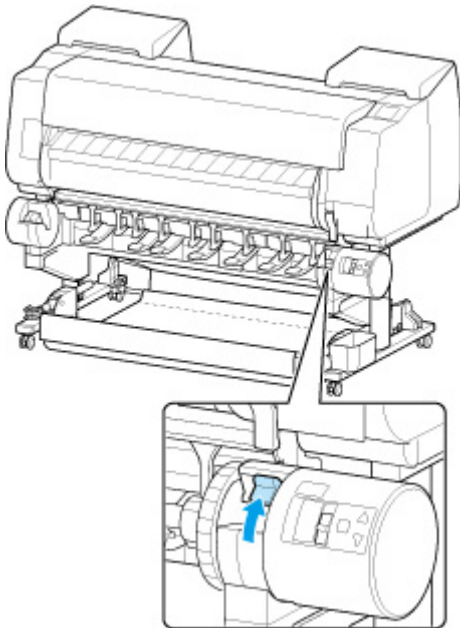

7. Hold flanges (A) so that holder stopper is on left, align roll holder shaft with roll holder slot left and right guide grooves (B), and load.

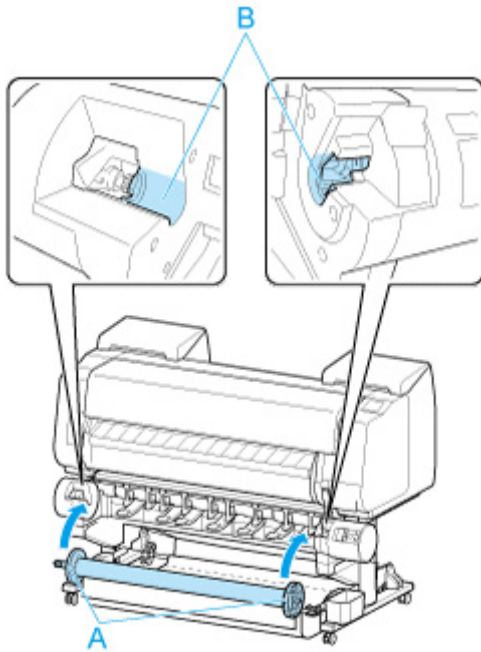

8. Change **Roll Holder Lock** switch on roll unit to locked position.

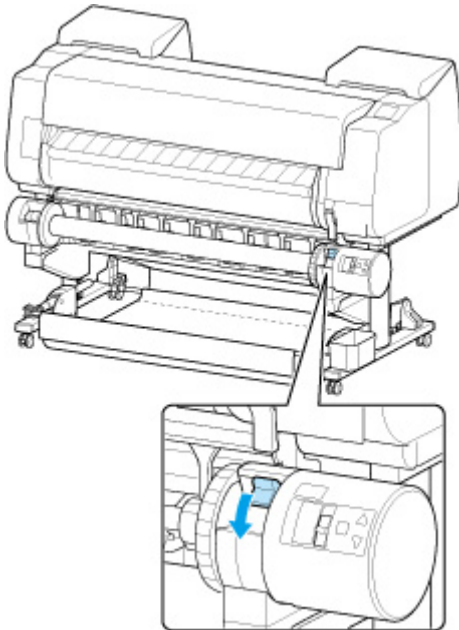

9. Change the feed flap switch on top of the roll unit so that the switch indicator (A) is aligned with • (B) position on the take-up icon.

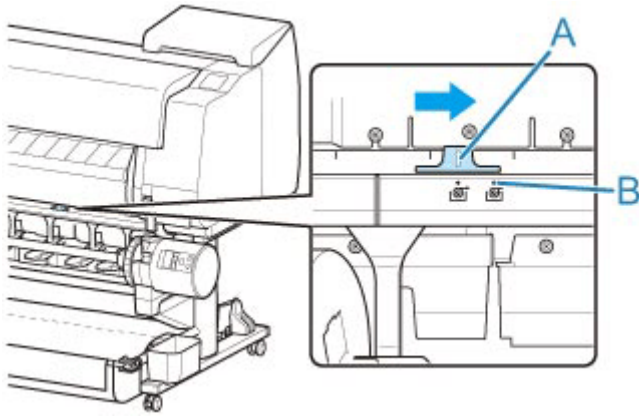

- 10.** Change **Inward/Outward Winding Changeover** switch on roll unit to desired winding direction.

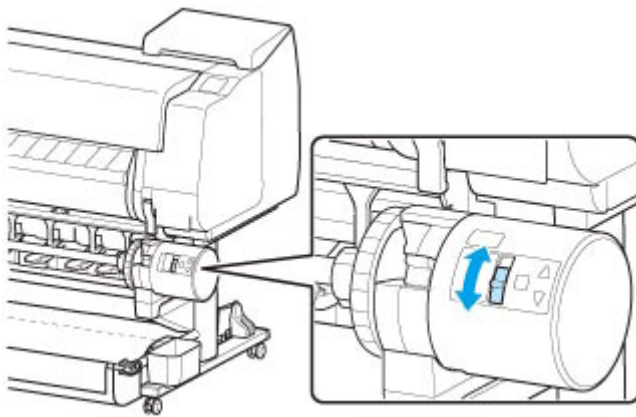

»» Note

- For the winding direction of the roll paper, you can select either outward winding to make the printed surface on the outside of the roll or inward winding to make the printed surface on the inside of the roll.

- 11.** Follow these steps to secure the leading edge of the roll paper to the paper core with tape.

- **If message appears on touch screen to confirm whether or not to advance paper automatically so it can be secured with tape**

1. Select **Yes**.

The leading edge of the roll paper advances until it is close to the roll unit.

2. Hold center of leading edge of roll paper, align right edge of take-up spool paper core's right edge and tape center to paper core while pulling on roll paper evenly.

- Outward Winding

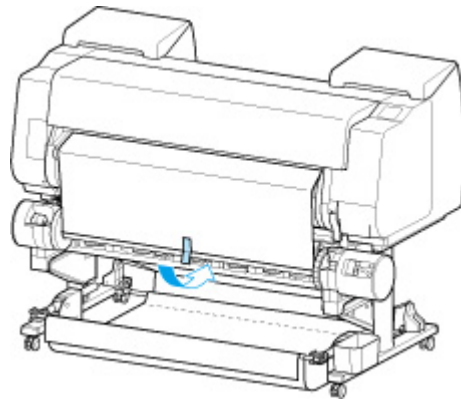

- Inward Winding

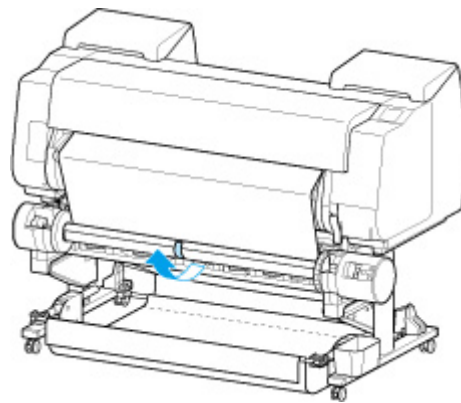

►► Important

- If winding with inward winding, you must pass the leading edge of the roll paper to the back of the paper core and secure with tape. If this operation is difficult, you can also remove the roll holder, push the roll paper into the back, reinstall the roll holder, and pass the roll paper to the back of the paper core.

3. Align right edge of roll paper to right edge of paper core while pulling on roll paper evenly, and secure with tape.
4. While making sure that roll paper is flat, secure left edge of roll paper to paper core with tape.
 - Outward Winding

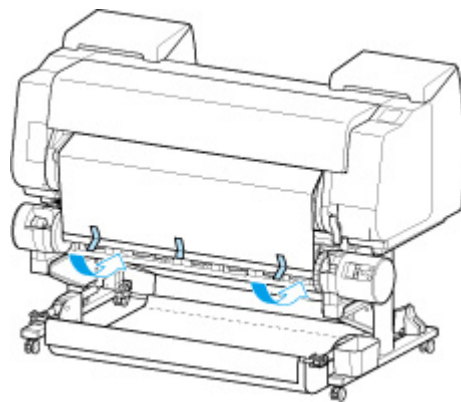

- Inward Winding

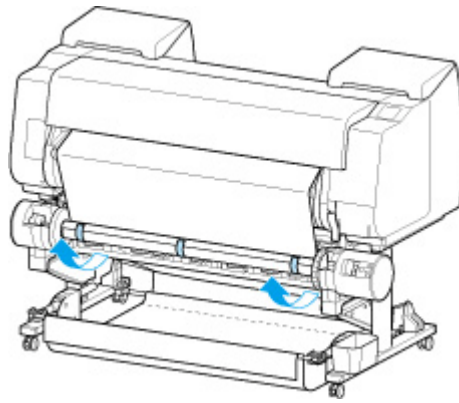

►► Important

- Secure the left and right edges of the roll paper with tape within 2.0 inches (50 mm) of the edges so that neither end of the roll paper lift up.
- When rewinding heavyweight paper, use strong adhesive tape to fasten it. Otherwise, a rewinding problem may result.
- If you use a paper core narrower than the paper to be wound, adjust the position of the holder stopper, so that there is a gap between the holder stopper and the paper.

5. Make sure the leading edge of the roll paper is not lifting up from the paper core, and if there are places lifting up, tape in additional places so that the paper does not lift up.

6. Push roll holder downward, check that roll holder is not lifting up, and select **OK**.

- Outward Winding

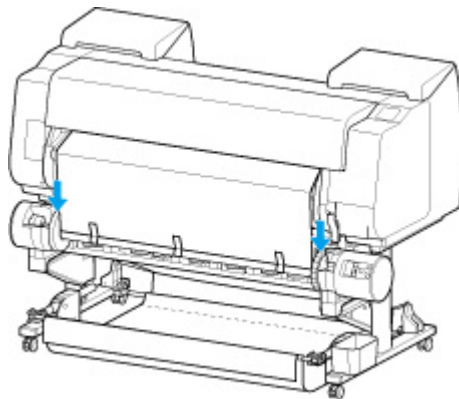

- Inward Winding

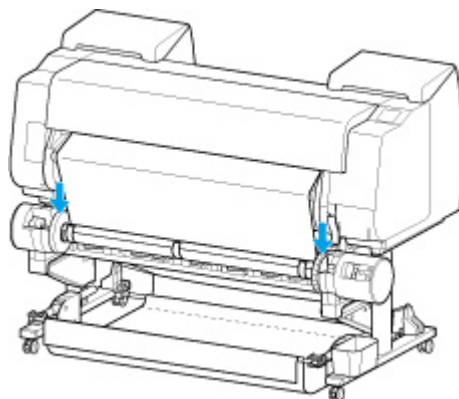

►► Important

- If the roll holder lifts up, it may cause an error.

7. To stabilize operations when starting taking up, advance roll paper with operation panel and wind roll paper approximately one revolution.

➔ [Feeding Roll Paper Manually](#)

8. Push roll holder downward again, and check that roll holder is not lifting up.

The winding preparation is complete. When printing to the roll starts, the roll paper can be automatically wound.

• If Ready to print appears on touch screen

1. Manually advance roll paper or start printing, and wait for leading edge of roll paper to reach roll unit.

➔ [Feeding Roll Paper Manually](#)

2. Hold center of leading edge of roll paper, align right edge of take-up spool paper core's right edge and tape center to paper core while pulling on roll paper evenly.

- Outward Winding

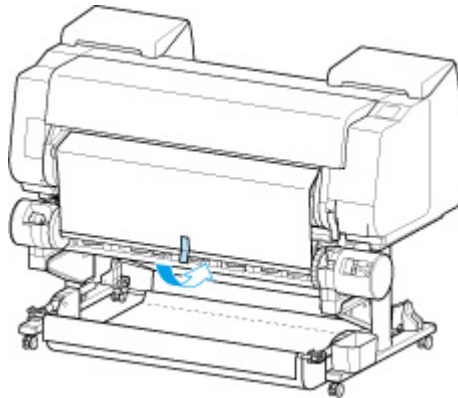

- Inward Winding

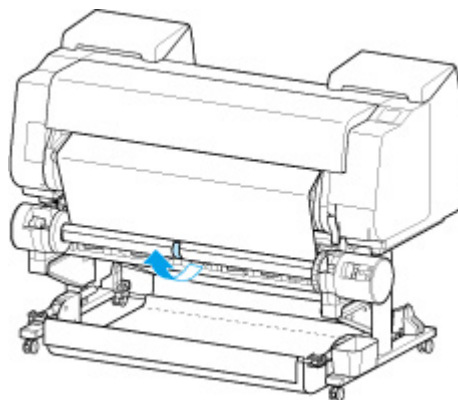

►► Important

- If winding with inward winding, you must pass the leading edge of the roll paper to the back of the paper core and secure with tape. If this operation is difficult, you can also remove the roll holder, push the roll paper into the back, reinstall the roll holder, and pass the roll paper to the back of the paper core.

3. Align right edge of roll paper to right edge of paper core while pulling on roll paper evenly, and secure with tape.
4. While making sure that roll paper is flat, secure left edge of roll paper to paper core with tape.

- Outward Winding

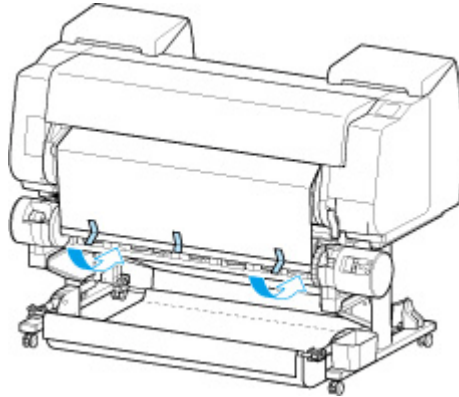

- Inward Winding

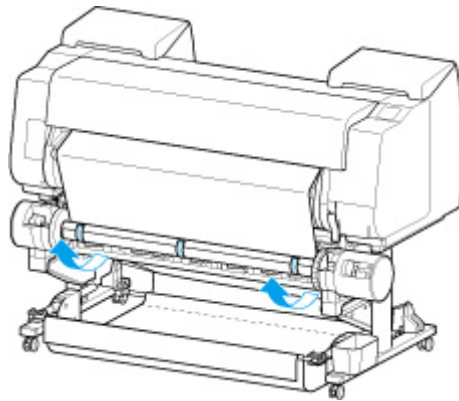

▶▶▶ Important

- Secure the left and right edges of the roll paper with tape within 2.0 inches (50 mm) of the edges so that neither end of the roll paper lift up.
- When rewinding heavyweight paper, use strong adhesive tape to fasten it. Otherwise, a rewinding problem may result.
- If you use a paper core narrower than the paper to be wound, adjust the position of the holder stopper, so that there is a gap between the holder stopper and the paper.

5. Make sure the leading edge of the roll paper is not lifting up from the paper core, and if there are places lifting up, tape in additional places so that the paper does not lift up.
6. Push roll holder downward and check that roll holder is not lifting up.
 - Outward Winding

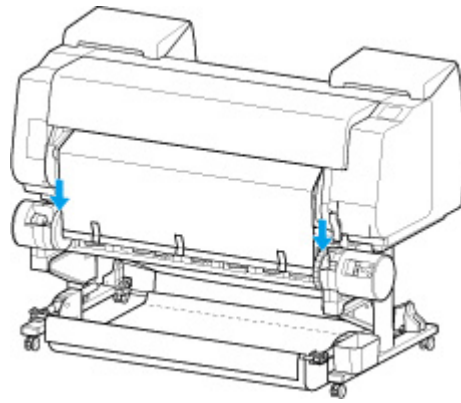

- Inward Winding

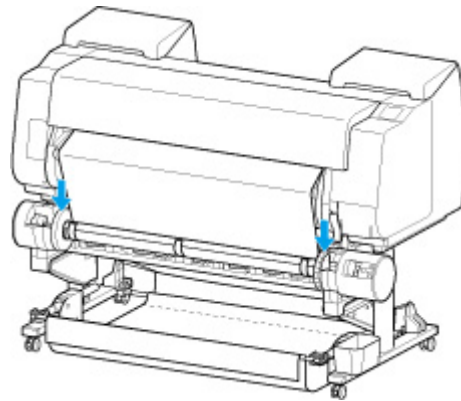

►► Important

- If the roll holder lifts up, it may cause an error.

7. Make sure **Inward/Outward Winding Changoever** switch on roll unit is in desired direction and press **Auto Take-up/Pause** button.

The **Pause** lamp, which has been lighted up to this point, turns off, and the **Auto Take-up** lamp lights up instead.

The winding preparation is complete. During printing, the winding starts. Before printing, the winding starts at the same time as the printing.

►► Important

- When winding inwardly, loosening of the wound paper can be prevented by pressing the roll paper with the arm. However, doing so may produce pressure traces on the paper. In this case, tap the roll unit area of the media information display area and set **Paper retention settings** to **Release**.

Removing Printed Paper from the Roll Unit

Note

- By selecting the paper settings display area and then **Take-up mode** area when setting **Take-up mode** and setting **Wind up after cutting** to **Enable** in advance, you can omit steps 6 and 7 below, because when the paper is cut after printing, the next paper will be automatically taken up after that. However, be careful when using easily damaged roll paper because the roll paper touches the roller when paper is cut.

1. Select the paper setting display area on Home screen.

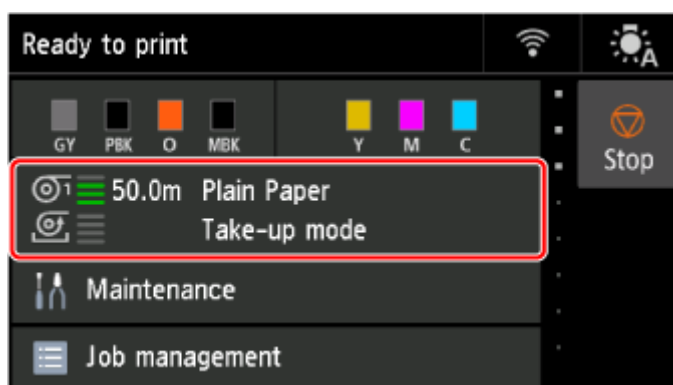

2. Select the **Roll paper 1** area.

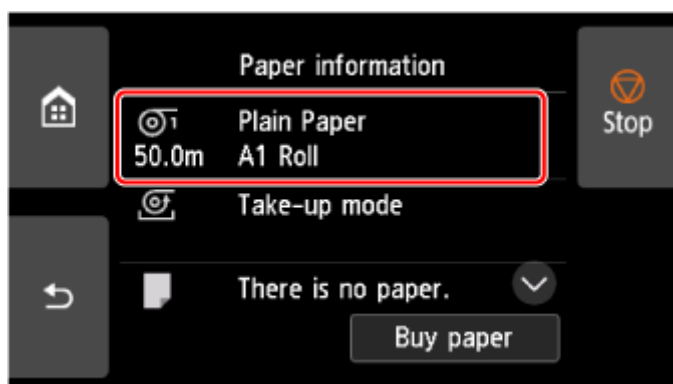

3. Select **Feed/cut**.

4. Tap or touch **Advance** and **Rewind** to move roll paper forward or back.

With the winding direction set to outward winding, advance the length of one circumference of the roll or more to protect the print side.

5. Select **Cut paper**.

6. Hold printed paper between output guide and roll unit, then select **Yes**.

The roll is now cut.

▶▶▶ Important

- When cutting the roll paper, always hold the printed paper. If cut without holding the printed paper, the paper may fall to the floor and become soiled.

7. While holding trailing edge of printed paper, press **Take-up** or **Rewind** button to wind printed paper.

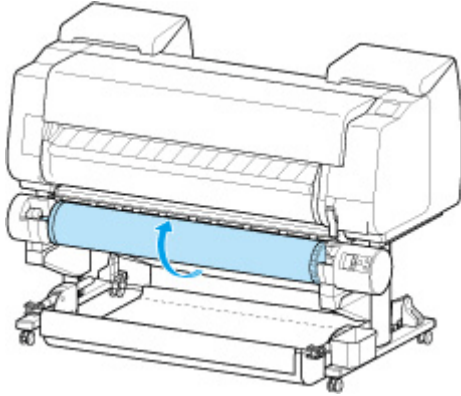

Apply adhesive tape to the rewound paper to hold it in place, if necessary.

▶▶▶ Important

- Be careful not to scratch the printed surface.

8. Change **Roll Holder Lock** switch on roll unit to release position.

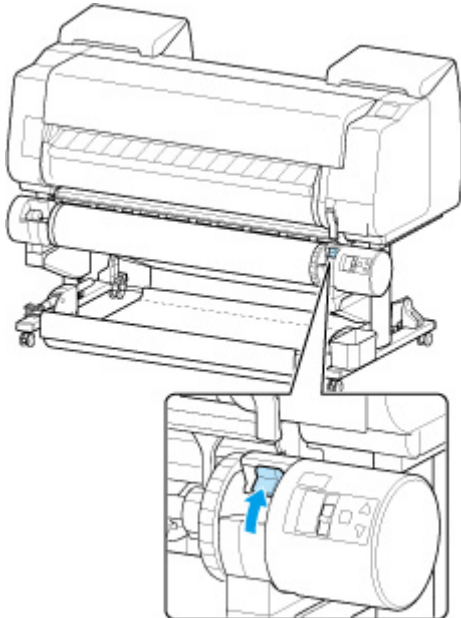

9. Hold roll holder by its flanges (A), and remove from roll unit.

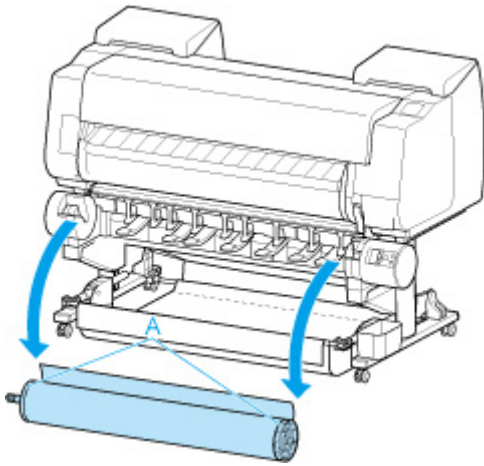

- 10.** Rotate the holder stopper lever (A) towards  to release the lock, and while holding the end plate (B), remove holder stopper from the roll holder.

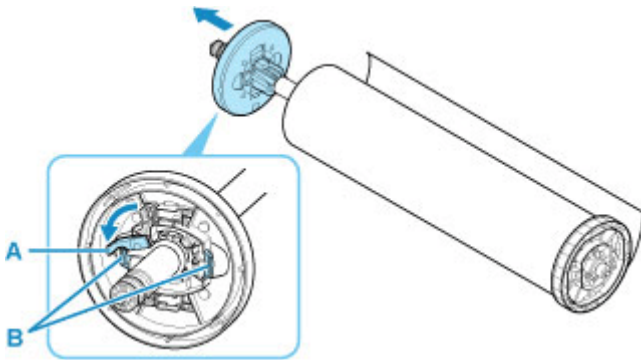

- 11.** Remove printed material that has been taken up, from roll holder for each paper core.

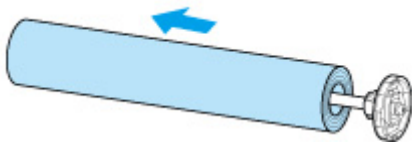

Stopping Printing

To cancel printing or reception of print jobs, tap **Stop** on the touch screen.

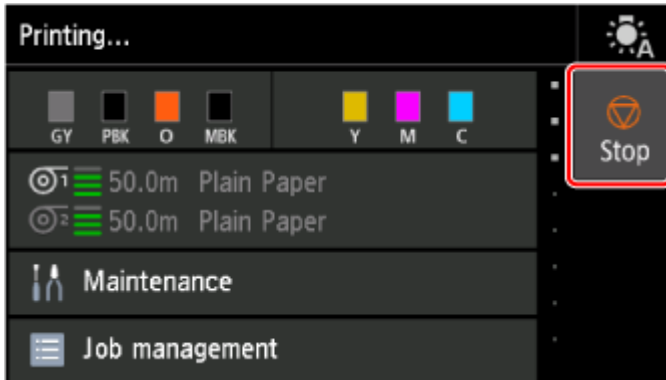

When you tap **Stop** during printing, the behavior of the printer varies depending on the current status.

- **You tap Stop before printing starts**

A confirmation message is displayed. To cancel the print job, select **Yes**.

- **You tap Stop during printing**

A confirmation message is displayed. To cancel the print job immediately, select **Yes**.

Pausing Printing

During printing, if you set **Pause printing** to **Enable**, the printer enters a state in which printing is paused, after the completion of the printing process when this setting was made.

In this state, all printing is not executed.

To restore normal operation after pausing printing, set **Pause printing** to **Disable**.

▶▶▶ Note

- In the following cases, the status is cleared even if you do not set **Pause printing** to **Disable**.
 - When paper is advanced
 - If you changed the media type from the paper settings display area

1. Select  **Job management** on Home screen during printing.

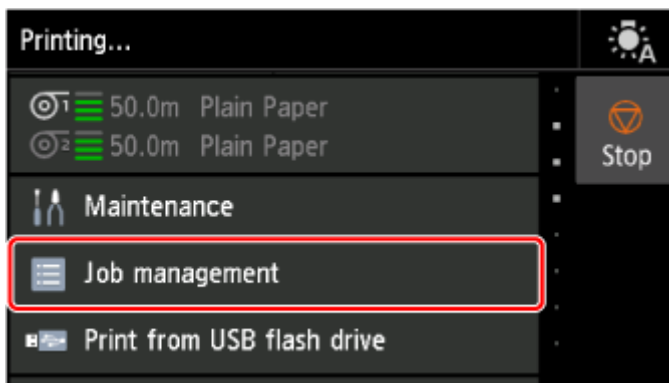

2. Select **Pause printing**.

3. Select **Enable**.

Printing

▶ **Printing from Your Computer (Windows)**

- Printing with Easy Setup **▼ Basics**
- Printing Photos and Business Documents
 - Printing By Setting Print Purpose
 - Edit in PosterArtist and Print
- Printing CAD Drawings
 - Printing By Setting Print Purpose
- Scaled Printing
- Printing to Oversized Paper Sizes
- Setting Paper Dimensions (Custom Size)
- Printing Hanging and Horizontal Banners (Large-Format Printing)
- See more...

▶ **Printing from Computer (macOS)**

- Printing with Easy Setup **▼ Basics**
- Scaled Printing
- Printing to Oversized Paper Sizes
- Setting Paper Dimensions (Custom Size)
- Printing Hanging and Horizontal Banners (Large-Format Printing)
- See more...

▶ **Printing from Printer**

- Printing Data Saved on USB Flash Drive

▶ **Printing from Smartphone/Tablet**

- Print Easily from a Smartphone or Tablet with Canon PRINT
- Printing from iOS Device (AirPrint)

▶ **Enlarging Copy with imageRUNNER ADVANCE**

▶ **Using PIXMA/MAXIFY Cloud Link**

► **Managing Print Jobs**

- Handling Print Jobs

- Using the Printer Hard Disk to Handle Print Jobs

Printing from Computer (macOS)

- **Printing with Easy Setup** 📄 Basic
- **Setting the Number of Copies and Printing Order**
- **Using Roll Unit to Use 2-Level Rolls**
- **Changing the Print Quality and Correcting Image Data**
- **Scaled Printing**
- **Printing to Oversized Paper Sizes**
- **Setting Paper Dimensions (Custom Size)**
- **Set a Custom Size Roll Width**
- **Printing without Edges Based on the Scenarios**
- **Printing Hanging and Horizontal Banners (Large-Format Printing)**
- **Printing by Dividing/Joining Documents**
- **Printing Document in Center of Paper**
- **Printing by Saving Roll Paper**
- **Switching the Paper Source to Match the Purpose**
- **Cutting Roll Paper after Printing**
- **Printing Using AirPrint**

Printing with Easy Setup

The simple setup procedure for carrying out appropriate printing on this printer is as follows:

1. [Check that printer is turned on](#)

2. Load paper on the printer

Set [roll paper](#) or [cut sheet](#).

3. Select the printer

Select your model from the **Printer** list in the [Print Dialog](#).

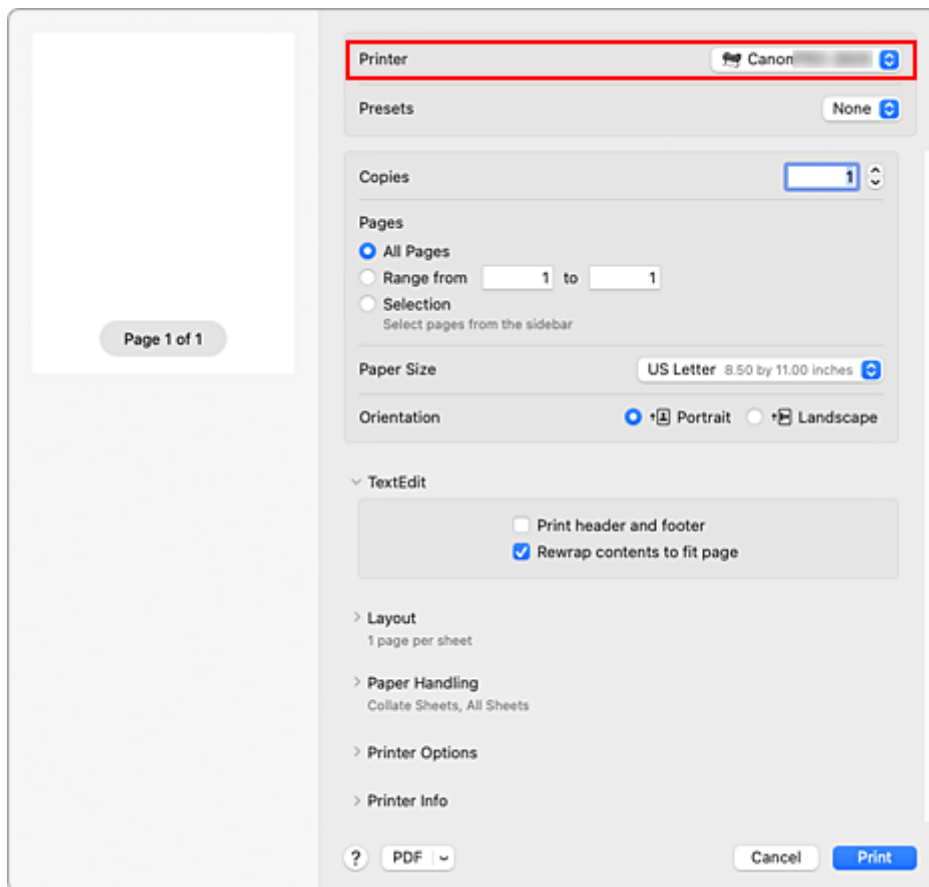

4. Select the paper size

For **Paper Size**, select the paper size to be used.

If necessary, set the number of copies, the pages to be printed, and the orientation.

5. Select **Quality & Media** from **Printer Options**

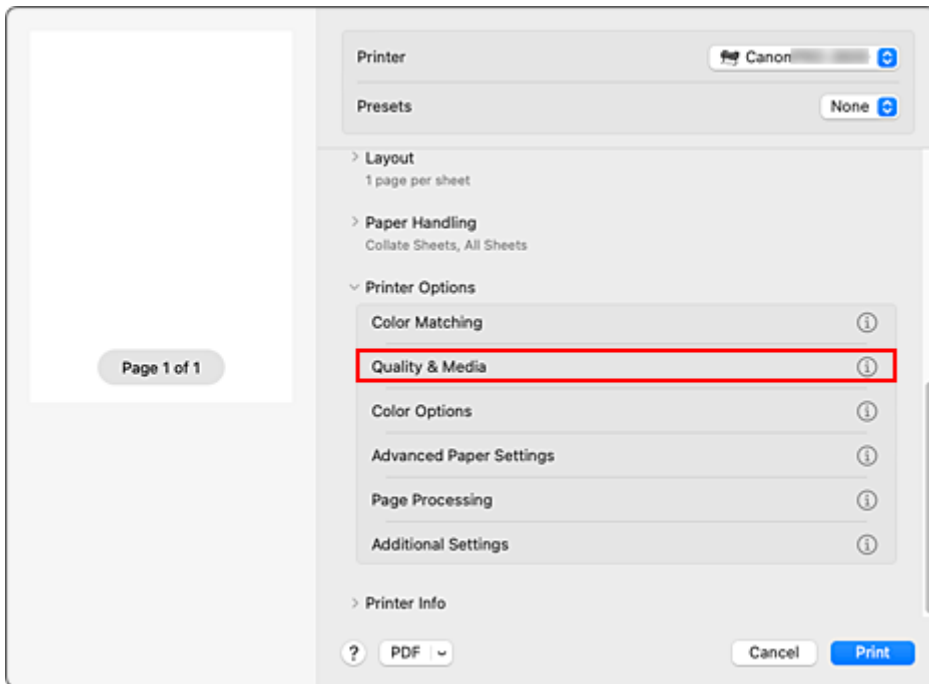

6. Select the media type

For **Media Type**, select the same paper type loaded in the printer.

If **Auto (Use Printer Settings)** is selected, the paper configured in printer settings is printed.

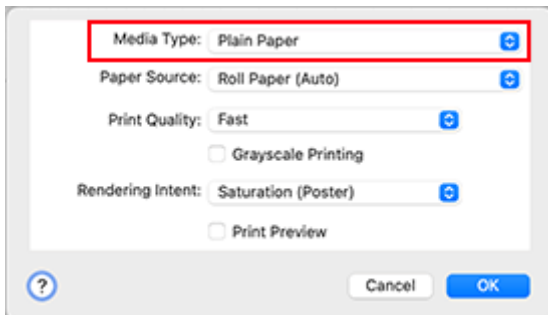

»»» Important

- In the **Presets** section, click **Save Current Settings as Preset...** to [register the specified settings](#).
- See "Paper Information List" for Canon authentic paper or Canon output check paper.

7. Select the paper source

For **Paper Source**, select the setting that matches your purpose.

»»» Important

- The paper feed method will differ depending on the lower level (roll paper 2) settings or roll unit option settings.

8. Select the print quality

For **Print Quality**, select **High**, **Standard** or **Fast** according to your purpose.

»» Important

- The print quality settings that can be selected may differ depending on a printing profile.

9. Select **Page Processing** from **Printer Options**

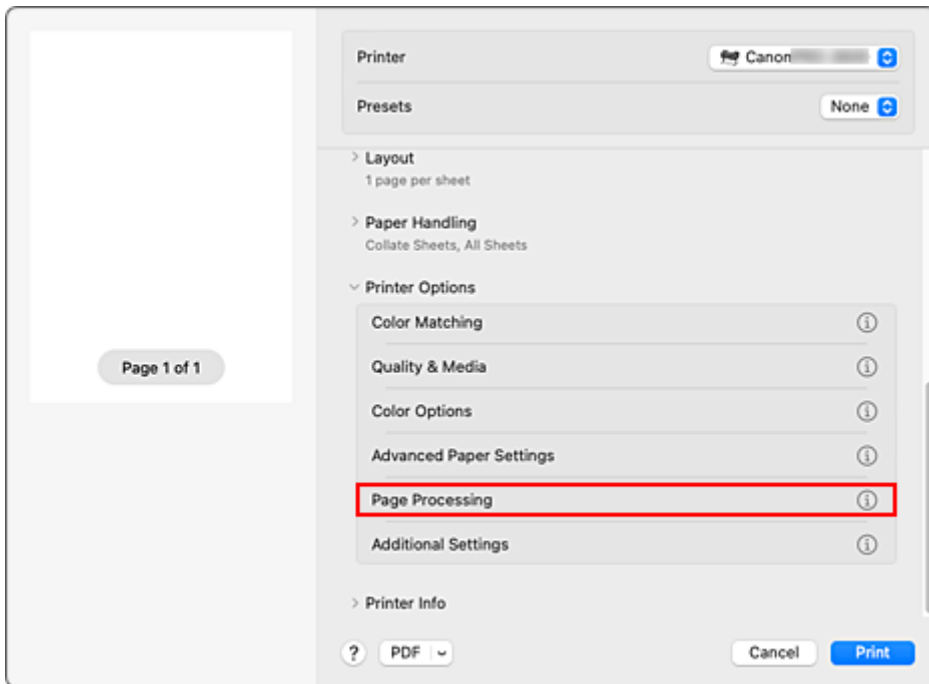

10. Selecting Roll Paper Width

If you selected a roll paper for **Paper Source** in **Quality & Media**, set **Roll Paper Width** to the width of the roll paper loaded in the printer.

»» Important

- If cut sheet is selected for the paper source, **Roll Paper Width** is grayed out and cannot be set.

11. Complete the setup

Click **Print**.

When you execute print, the document will be printed in accordance with the type and size of the media.

»» Note

- If the paper settings in the printer driver differ from the paper information registered on the printer, an error message may appear on the printer's operation panel. You can still print but you may not be able to obtain correct print results.

Setting the Number of Copies and Printing Order

Collate Sheets + Reverse Collate Sheets + Normal

Reverse

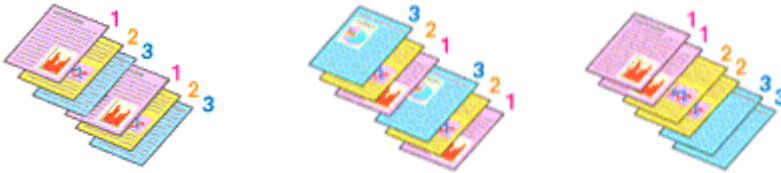

The procedure for specifying the number of copies and printing order is as follows:

1. Specify the number of copies to be printed

Specify the number of copies to print from the **Copies** in the [Print Dialog](#).

2. Select **Paper Handling**

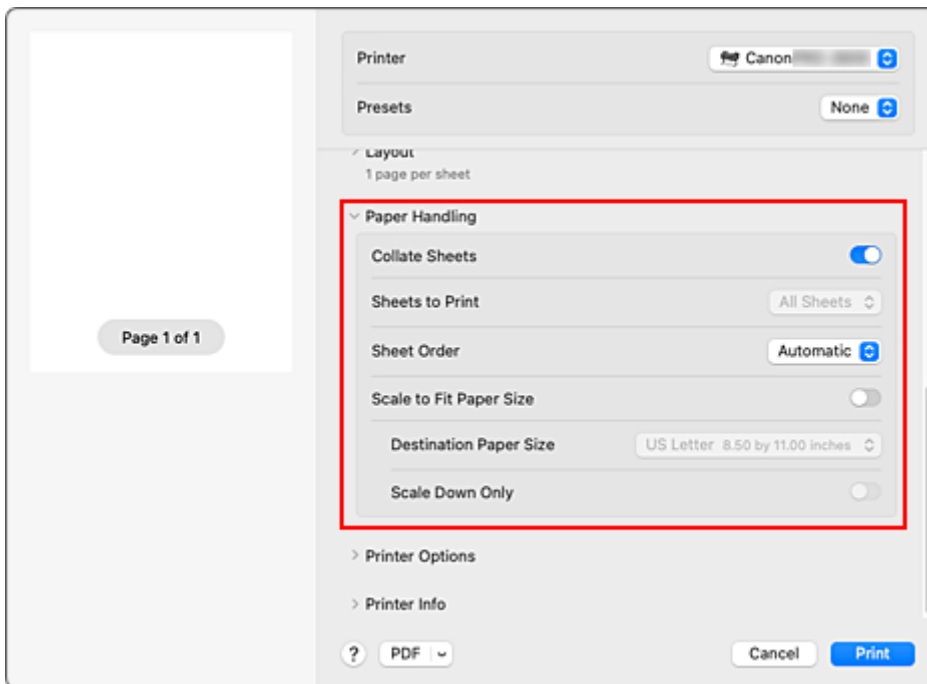

3. Check the **Collate Sheets** check box when you are specifying multiple copies in the **Copies** box

Turn on **Collate Sheets** to print all the pages of a single copy together.

Turn off this setting to print all pages with the same page number together.

4. Specify the print order

Check **Page Order**.

When you select **Reverse**, printing starts from the last page.

When you select **Automatic** or **Normal**, printing starts from the first page.

5. Complete the setup

Click **Print**.

When you execute print, the specified number of copies will be printed with the specified printing order.

Important

- When the application software that you used to create the document has the same function, specify the settings on the printer driver. However, if the print results are not acceptable, specify the function settings on the application software. When you specify the number of copies and the printing order with both the application software and this printer driver, the number of copies may be multiplied numbers of the two settings or the specified printing order may not be enabled.

Using Roll Unit to Use 2-Level Rolls

- **About 2-Level Roll Switching**
- **Setting the Paper Rolls in the Printer According to the Intended Use**
- **Printing by Automatically Switching Upper-level and Lower-level Roll Papers**
- **How to Switch Paper Rolls**
- **Reflect Roll Unit Settings in the Printer Driver**

About 2-Level Roll Switching

This printer allows you to load roll paper in two levels, the upper level (Roll 1) and the lower level (Roll 2) and to automatically switch between Roll 1 and Roll 2 depending on the print job.

Printing by automatically switching Roll 1 and Roll 2 in this way is called "2-level roll switching."

- For instructions on setting the paper, see "[Setting the Paper Rolls in the Printer According to the Intended Use.](#)"
- For the 2-level roll switching procedure, see "[Printing by Automatically Switching Upper-level and Lower-level Roll Papers.](#)"
- Guidelines on how to switch Roll 1 and Roll 2 for certain cases are summarized in "[How to Switch Paper Rolls.](#)"

Refer to this section if a document cannot be printed as intended or as necessary.

Setting the Paper Rolls in the Printer According to the Intended Use

If you want to switch the 2-level rolls, set the paper rolls on the upper and lower level of the printer in one of the ways described below depending on the intended use.

- When automatically switching from paper roll 1 to paper roll 2 to match the paper size specified for the print job

Set two paper rolls of the same type of paper but of different width on the upper and on the lower trays.

Example of how to set the paper

Paper-feeding tray	Roll Width	Media Type
Upper-level	24 in Roll (609.6mm)	Plain Paper
Lower-level	A1/A2 Roll (594.0mm)	Plain Paper

- When automatically switching from paper roll 1 to paper roll 2 role to match the paper type specified for the print job

Set two paper rolls of the same width but of different types of paper on the upper and on the lower trays. Alternatively, set two paper rolls of different width and different types of paper on the upper and on the lower trays.

Setting the paper (Example 1)

Paper-feeding tray	Roll Width	Media Type
Upper-level	A1/A2 Roll (594.0mm)	Plain Paper
Lower-level	A1/A2 Roll (594.0mm)	Canon Coated Paper

Setting the paper (Example 2)

Paper-feeding tray	Roll Width	Media Type
Upper-level	24 in Roll (609.6mm)	Plain Paper
Lower-level	A1/A2 Roll (594.0mm)	Canon Coated Paper

»» Important

- 2-level roll switching is not possible when the paper rolls being fed on the platen are not compatible with automatic cut-off. For checking which types of paper are compatible with automatic cut-off, look up the paper you want to use on the "Paper Information List."

»» Note

- For information on how to set the paper rolls in the printer, see "[Handling rolls](#)"
- When rolls of different types of paper and of different width are set in the upper and lower trays, the paper roll matching the type of paper specified for the print job will be used. Depending on the settings, an error may occur causing the wrong paper roll to be used; in such cases, it is recommended that, instead of using 2-level roll switching, you specify which one is best between paper roll 1 and paper roll 2 and print.

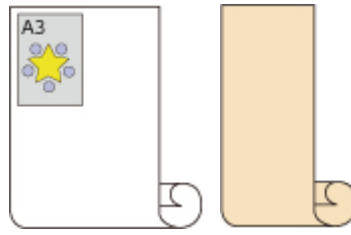

Document
Size: A3
Media Type: Plain Paper

Roll 1:
ISO A1/A2
Plain Paper

Roll 2:
ISO A3/A4
Glossy Paper

- To learn how to switch paper- feeding trays, see "[How to switch paper rolls.](#)"

Printing by Automatically Switching Upper-level and Lower-level Roll Papers

You can print by automatically switching Roll Paper 1 and Roll Paper 2 depending on the print job.

The procedure for printing by automatically switching Roll Paper 1 and Roll Paper 2 is as follows:

1. Select the paper size from the [Print Dialog](#)

For the **Paper Size**, select the same size as the source document created by the application software.

2. Select **Quality & Media** from **Printer Options**

3. Select the media type

For **Media Type**, select the same paper type loaded in the printer.

If **Auto (Use Printer Settings)** is selected, the paper configured in printer settings is printed.

»»» Important

- If the lower roll unit is not loaded or if the roll unit that was set as the take-up unit is loaded, the roll paper cannot be switched automatically.

4. Select the paper source

For **Paper Source**, select **Roll Paper (Auto)**.

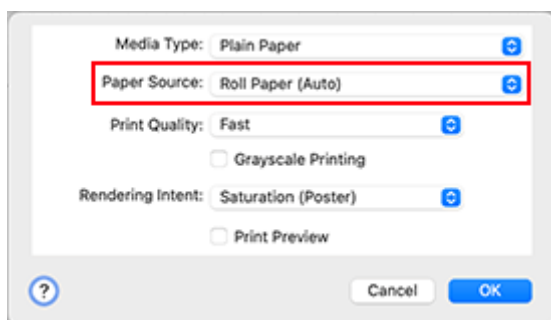

»»» Important

- The paper feed method will differ depending on the lower level (roll paper 2) settings or roll unit option settings.

5. Select **Page Processing** from **Printer Options**

6. Selecting Roll Paper Width

For **Roll Paper Width**, select the width of the roll paper loaded in the printer.

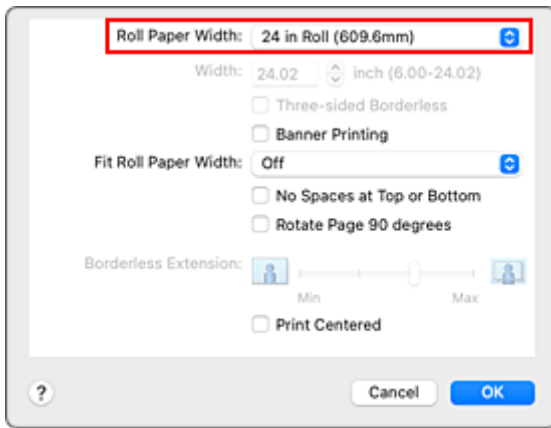

7. Selecting the printing method for the roll paper

When performing enlarged/reduced printing of the source document in accordance with the roll paper width, select **On (Bordered)** or **On (Borderless)** from **Fit Roll Paper Width**.

8. Set the other items

To rotate the document 90 degrees and print it, select the **Rotate Page 90 degrees** check box.

▶▶▶ Note

- If you rotate a portrait document 90 degrees and print it at that horizontally, you may be able to save paper depending on the paper size.

▶▶▶ Important

- When you select the **Rotate Page 90 degrees** check box, an error will occur when attempting to print if the vertical length of the document does not fit in the width set in **Roll Paper Width**. Therefore to use this function, correctly set **Roll Paper Width** to the width of one of the roll papers loaded in the printer.

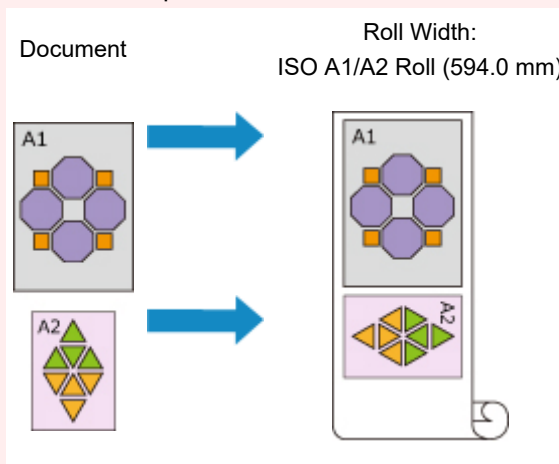

- If the roll papers loaded in the upper and lower levels are different media types, the document is printed on the roll paper that matches the media type specified in the print job. If the document is being rotated 90 degrees for printing and the roll papers loaded in the upper and lower levels have different widths and different media types, set the correct combination of width and media type so that they match one of the roll papers loaded in the printer.

9. Complete the setup

Click **Print**.

When you print, the paper source is switched automatically to roll paper.

»» Important

- On the operation panel, if **Printer settings** -> **Paper-related settings** -> **Roll paper auto switching** is set to **Do not identify size**, the document may be printed on the unintended roll paper. Before printing, confirm that the setting in the operation panel is set to **Identify size**.
- 2-level roll switching is not possible when the paper rolls being fed on the platen are not compatible with automatic cut-off. For checking which types of paper are compatible with automatic cut-off, look up the paper you want to use on the "Paper Information List."

»» Note

- For details about how to switch the source levels depending on the print job, see "[How to Switch Paper Rolls](#)."

How to Switch Paper Rolls

Here we will explain how the roll paper set in the upper and lower trays of the printer are switched. Refer to this information when necessary, for example, when documents will not print as expected, etc.

If you select **Roll Paper (Auto)** under **Paper Source** in the **Quality & Media**, the roll paper that is best suited for the print job will be automatically selected.

Whether paper roll 1 or paper roll 2 is selected, is determined through a sequence of judgment based on the 7 conditions in the table below.

At such times, the **Printer settings** -> **Paper-related settings** -> **Detect paper setting mismatch** in the Printer unit's operation panel will switch to the result of the judgment based on the process described below.

- [If the Detect paper setting mismatch setting is set on Pause or Hold job](#)
- [If the Detect paper setting mismatch setting is Display warning or Do not detect](#)

Important

- If the lower roll unit is not loaded or if the roll unit that was set as the take-up unit is loaded, the roll paper cannot be switched automatically.

Note

- If Error or On hold are displayed, replace the paper to match the requirements of the print job.
- In order to minimize paper waste, it is recommended that you configure the operation panel on the Printer unit as indicated below.
 - In **Printer settings** -> **Paper-related settings**, set **Roll paper auto switching** to **Identify size**
 - In Paper settings display area -> (Each paper type) -> **Paper settings** -> **Advanced**, set **Detect paper width** to **Enable**

If the Detect paper setting mismatch setting is set on Pause or Hold job

Condition		Situation	Judgment result
Condition 1	Whether the paper roll loaded on the printer is long enough to print the paper size specified for the print job.	Only one of either paper roll 1 or paper roll 2 is long enough	Select the paper roll of sufficient length
		Neither paper roll 1 nor paper roll 2 are long enough	Error
		Both paper roll 1 and paper roll 2 are long enough	To Condition 2
		On the Printer's menu, Manage remaining roll amount is set on Disable (length of the paper roll cannot be determined)	
Condition 2	Whether the paper roll loaded on the printer matches the paper type specified for the print job.	Only one of either paper roll 1 or paper roll 2 matches the paper type	Select the paper roll matching the paper type

		Neither roll 1 nor roll 2 match the paper type	Error / On hold
		Both paper roll 1 and paper roll 2 match the paper type	To Condition 3
Condition 3	In the Printer menu, how has the Roll paper auto switching setting changed?	It has changed to Do not identify size	Select the paper roll currently being fed into the platen *1
		It has changed to Identify size	To Condition 4
Condition 4	If borderless printing has been indicated for the print job (if it has not, on to condition 5)	Only one of either paper roll 1 or paper roll 2 is compatible with borderless printing	Select the paper roll compatible with borderless printing
		Neither paper roll 1 nor paper roll 2 are compatible with borderless printing	Error
		Both paper roll 1 and paper roll 2 are compatible with borderless printing	To Condition 5
Condition 5	Whether the width of the paper roll loaded on the printer matches the paper width specified for the print job (only when printing borderless or enlarging/reducing)	Only one of either paper roll 1 or paper roll 2 has the width specified for the print job	Select the paper roll of the matching width
		Neither paper roll 1 nor paper roll 2 have a width matching the one specified for the print job	Error / On hold
		Both paper roll 1 and paper roll 2 have a width matching the one specified for the print job	To Condition 6
		Paper roll width has not been specified for the print job	
Condition 6	Whether the width of the paper size specified for the print job fits within the width of the paper roll loaded on the printer.	The width of the paper size specified for the print job only fits within the width of paper roll 1 or paper roll 2	Select the paper roll in which the width of the paper size fits comfortably
		The width of the paper size specified for the print job does not fit within the width of either paper roll 1 or paper roll 2	Error
		The width of the paper size specified for the print job fits within the	To Condition 7

		width of both paper roll 1 and paper roll 2	
Condition 7	Is the width of paper roll 1 different from the width of paper roll 2?	Roll width is different	Select the paper roll whose width is closer to the width specified for the print job
		Roll width is the same	Select the paper roll currently being fed into the platen *1

*1 In the following cases, neither roll 1 nor roll 2 are being fed onto the platen. In such cases, paper roll 1 is selected.

- When the printer has switched to sleep mode and has returned to the initial position
- When the printer has been turned on
- When cut sheet has been fed into the printer and has exited it

If the Detect paper setting mismatch setting is set on Display warning or Do not detect

Condition		Situation	Judgment result
Condition 1	Whether the paper roll loaded on the printer is long enough to print the paper size specified for the print job.	Only one of either paper roll 1 or paper roll 2 is long enough	Select the paper roll of sufficient length
		Neither paper roll 1 nor paper roll 2 are long enough	Error
		Both paper roll 1 and paper roll 2 are long enough	To Condition 2
		On the Printer's menu, Manage remaining roll amount is set on Disable (length of the paper roll cannot be determined)	
Condition 2	Whether the paper roll loaded on the printer matches the paper type specified for the print job.	Only one of either paper roll 1 or paper roll 2 matches the paper type	Select the paper roll matching the paper type
		Neither roll 1 nor roll 2 match the paper type	To Condition 3
		Both paper roll 1 and paper roll 2 match the paper type	
Condition 3	In the Printer menu, how has the Roll paper auto switching setting changed?	It has changed to Do not identify size	Select the paper roll currently being

			fed into the platen *1
		It has changed to Identify size	To Condition 4
Condition 4	If borderless printing has been indicated for the print job (if it has not, on to condition 5)	Only one of either paper roll 1 or paper roll 2 is compatible with borderless printing	Select the paper roll compatible with borderless printing
		Neither paper roll 1 nor paper roll 2 are compatible with borderless printing	Error
		Both paper roll 1 and paper roll 2 are compatible with borderless printing	To Condition 5
Condition 5	Whether the width of the paper roll loaded on the printer matches the paper width specified for the print job (only when printing borderless or enlarging/reducing)	Only one of either paper roll 1 or paper roll 2 has the width specified for the print job	Select the paper roll of the matching width
		Neither paper roll 1 nor paper roll 2 have a width matching the one specified for the print job	To Condition 6
		Both paper roll 1 and paper roll 2 have a width matching the one specified for the print job	
		Paper roll width has not been specified for the print job	
Condition 6	Whether the width of the paper size specified for the print job fits within the width of the paper roll loaded on the printer.	The width of the paper size specified for the print job only fits within the width of paper roll 1 or paper roll 2	Select the paper roll in which the width of the paper size fits comfortably
		The width of the paper size specified for the print job does not fit within the width of either paper roll 1 or paper roll 2	To Condition 7
		The width of the paper size specified for the print job fits within the width of both paper roll 1 and paper roll 2	
Condition 7	Is the width of paper roll 1 different from the width of paper roll 2?	Roll width is different	Select the paper roll whose width is closer to the width specified for the print job

	Roll width is the same	Select the paper roll currently being fed into the platen *1
--	------------------------	---

*1 In the following cases, neither roll 1 nor roll 2 are being fed onto the platen. In such cases, paper roll 1 is selected.

- When the printer has switched to sleep mode and has returned to the initial position
- When the printer has been turned on
- When cut sheet has been fed into the printer and has exited it

Reflect Roll Unit Settings in the Printer Driver

Configure the settings of the roll unit in the printer driver so that they reflect those in the printer unit.

If you configure the settings of the roll unit in the printer driver so that they reflect those in the printer unit, the paper-feeding methods which can be set in the printer driver will switch to the state the printer unit was in.

Procedure for configuring the settings of the roll unit in the printer driver so that they reflect those in the printer unit.

1. Open **System Settings** and select **Printers & Scanners**
2. Select the name of your model from the list of printers and click **Options & Supplies...**
3. Reflect the settings of the roll unit

If you are using the lower tray (paper roll 2) as paper-feeding tray, place a checkmark next to **Roll Unit** in the **Options** tab (or the **Driver** tab).

▶▶ Important

- If the roll unit of the lower tray is not installed, or if the roll unit of the lower tray set in the winding device is installed, uncheck **Roll Unit**.

▶▶ Note

- Roll unit settings are automatically updated even when you are printing from the printer driver.

Changing the Print Quality and Correcting Image Data

- **Adjusting Color Balance**
- **Setting the Print Quality Level (Custom)**
- **Printing a Color Document in Monochrome**
- **Specifying Color Correction**
- **Adjusting Brightness**
- **Adjusting Contrast**

Adjusting Color Balance

You can adjust the color tints when printing.

Since this function adjusts color balance of the output by changing the ink ratios of each color, it changes the total color balance of the document. Use the application software when you want to change the color balance significantly. Use the printer driver only when you want to adjust the color balance slightly.

The following sample shows the case when color balance is used to intensify cyan and to diminish yellow so that the overall colors are more uniform.



No adjustment Adjust color balance

The procedure for adjusting color balance is as follows:

1. Select **Color Options** from **Printer Options** in the [Print Dialog](#)
2. Adjust color balance

There are individual sliders for **Cyan**, **Magenta**, and **Yellow**. Each color becomes stronger when the corresponding slider is moved to the right, and becomes weaker when the corresponding slider is moved to the left. For example, when cyan becomes weaker, the color red becomes stronger.

You can also directly enter a value linked to the slider. Enter a value in the range from -50 to 50. The current settings are displayed in the settings preview on the left side of the printer driver.

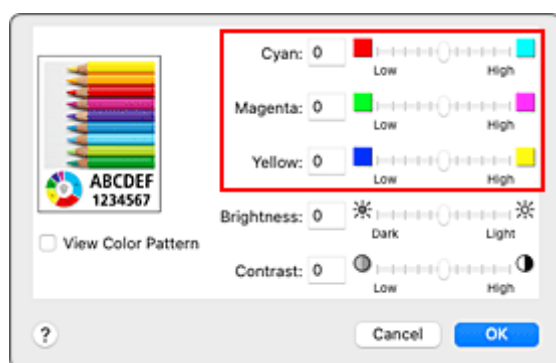

3. Complete the setup

Click **Print**.

When you execute print, the document is printed with the adjusted color balance.

Related Topics

- ➔ [Setting the Print Quality Level \(Custom\)](#)
- ➔ [Specifying Color Correction](#)
- ➔ [Adjusting Brightness](#)
- ➔ [Adjusting Contrast](#)

Setting the Print Quality Level (Custom)

The print quality level can be set in the **Custom**.

The procedure for setting the print quality level is as follows:

1. Select **Quality & Media** from **Printer Options** in the [Print Dialog](#)
2. Select the print quality

Select **Custom** for **Print Quality**.

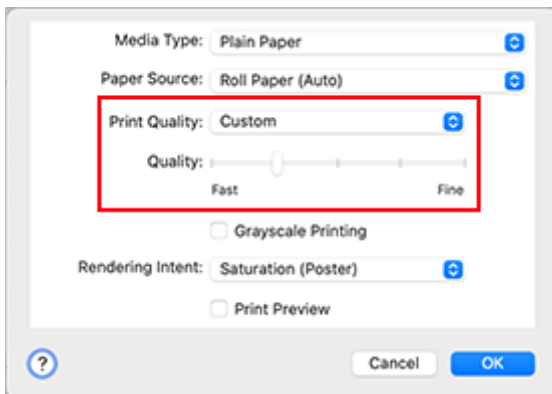

►►► Important

- If **Auto (Use Printer Settings)** is selected for **Media Type**, **Custom** cannot be selected.

3. Setting the print quality level

Move the **Quality** slider to select the print quality level.

►►► Important

- Certain print quality levels cannot be selected depending on the settings of media type.

4. Complete the setup

Click **Print**.

When you execute print, the image data is printed with the selected print quality level.

Related Topics

- ➔ [Specifying Color Correction](#)
- ➔ [Adjusting Color Balance](#)
- ➔ [Adjusting Brightness](#)
- ➔ [Adjusting Contrast](#)

Printing a Color Document in Monochrome

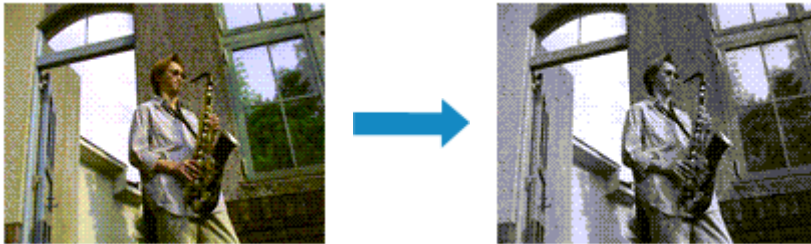

The procedure for printing a color document in monochrome is as follows:

1. Select **Quality & Media** from **Printer Options** in the [Print Dialog](#)
2. Set grayscale printing

Check the **Grayscale Printing** check box.

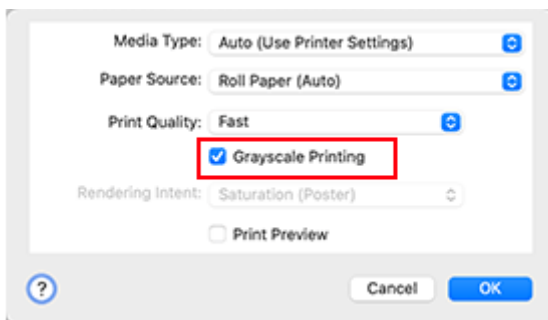

3. Complete the setup

Click **Print**.

When you execute print, the document is converted to grayscale data. It allows you to print the color document in monochrome.

►► Note

- With **Grayscale Printing**, inks other than black ink may be used as well.

Specifying Color Correction

You can specify the color correction method suited to the type of document to be printed. Normally, when data is printed, the printer driver automatically adjusts the colors.

When you want to print by using the color space of the image data effectively or by specifying a printing ICC profile from your application software, select **ColorSync**. When you want to print by having the printer driver correct the colors, select **Canon Color Matching**.

The procedure for specifying color correction is as follows:

1. Select **Color Matching** from **Printer Options** in the [Print Dialog](#)

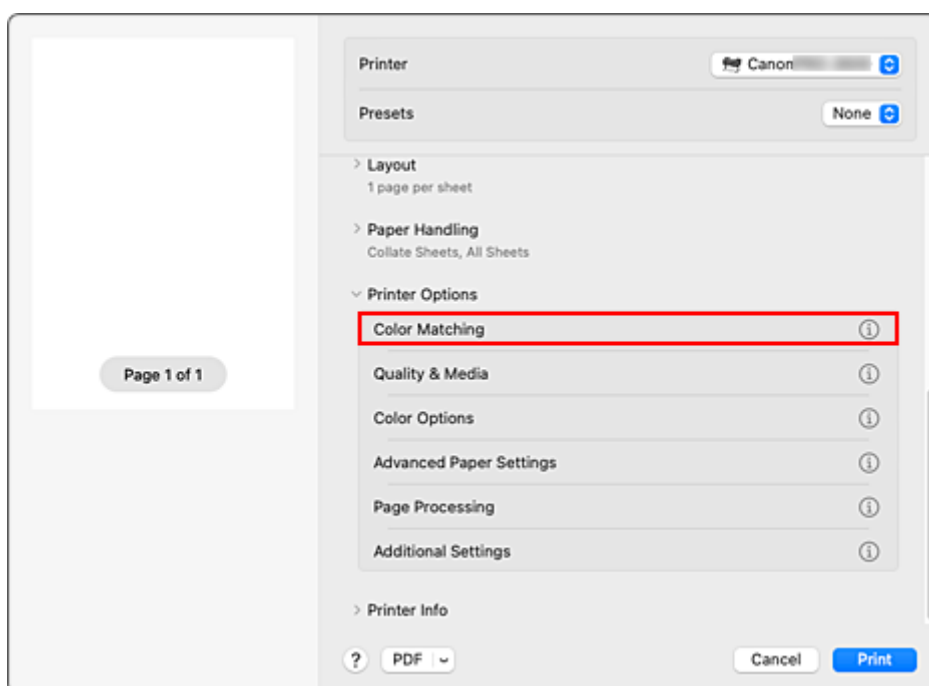

2. Select color correction

Select the item below that matches your purpose.

ColorSync

Perform color correction using ColorSync.

Canon Color Matching

The driver will perform necessary adjustments during printing.

For information about driver matching, see "[Adjusting Colors with the Printer Driver.](#)"

3. Complete the setup

Click **Print**.

When you execute print, the document data is printed with the specified color correction.

▶▶▶ Important

- Depending on the application software, when a printing ICC profile is specified from that application software, **Canon Color Matching** cannot be selected because **ColorSync** is selected automatically.

- The **Quality & Media** setting is necessary even when **ColorSync** or **Canon Color Matching** is selected.

Related Topics

- ➔ [Optimal Photo Printing of Image Data](#)
- ➔ [Adjusting Colors with the Printer Driver](#)
- ➔ [Printing with ICC Profiles \(Specifying an ICC Profile from the Application Software\)](#)
- ➔ [Printing with ICC Profiles \(Specifying an ICC Profile from the Printer Driver\)](#)

Optimal Photo Printing of Image Data

When people print images taken with digital cameras, they sometimes feel that the printed color tones differ from those of actual image or those displayed on the monitor.

To get the print results as close as possible to the desired color tones, you must select a printing method that is best suited to the application software used or to your purpose.

Color Management

Devices such as digital cameras, scanners, monitors, and printers handle color differently. Color management (color matching) is a method that manages device-dependent "colors" as a common color space.

For macOS, a color management system called "ColorSync" is built into the operating system. sRGB is one of the common color spaces that is frequently used.

ICC profiles convert device-dependent "colors" into a common color space. By using an ICC profile and carrying out color management, you can draw out the color space of the image data within the color reproduction area that the printer can express.

▶▶▶ Note

- Normally, image files are saved in JPEG format. Some digital cameras allow you to save images in a format called RAW. RAW data refers to an image saving format that requires a computer to develop the image. You can embed an input ICC profile tag into a RAW file by using special application software.

Selecting a Printing Method Suited to the Image Data

The recommended printing method depends on the color space of the image data or the application software to be used.

There are two typical printing methods.

Check the color space of the image data and the application software to be used, and then select the printing method suited to your purpose.

[Adjusting Colors with the Printer Driver](#)

Describes the procedure for printing by using the color correction function of the printer driver.

Select this function when you want to print impressions that are close to those displayed on the monitor, for example, if you corrected the colors while checking the print image on the monitor.

[Printing with ICC Profiles \(Specifying an ICC Profile from the Application Software\)](#)

Describes the procedure for printing by using the color space of the image data effectively.

You can print with a common color space by setting up the application software and the printer driver so that the color management matches the input ICC profile of the image data.

The method for setting up the printer driver differs depending on the application software to be used.

Adjusting Colors with the Printer Driver

To use printer driver matching when printing, turn on the printer driver's color correction function. Printer driver matching accurately applies the characteristics of data displayed on the monitor and allows you to obtain print results of impressions that are close to those displayed on the monitor.

▶▶▶ Important

- When printing using printer driver matching, Canon recommends that you set the monitor and the environment light as follows:
 - Monitor
 - Color temperature: D50 (5000K)
 - Brightness: 100 to 120cd/m²
 - Gamma: 2.2
 - Environment light
 - Fluorescent light for D50 color evaluation (color temperature 5000K, high color rendering properties)
 - Brightness when looking at printed materials: 500 lx ± 125 lx

▶▶▶ Note

- When printing from an application software that allows you to identify and specify ICC profiles, use an ICC profile for printing with that application software and select setting items that manage colors.

The procedure for adjusting colors with the printer driver is as follows:

1. Select **Color Matching** from **Printer Options** in the [Print Dialog](#)

2. Select color correction

Select **Canon Color Matching**.

3. Select **Quality & Media** from **Printer Options**

4. Select the rendering intent

Select the coloring adjustment method in **Rendering Intent**.

Perceptual (Photo)

Reproduces colors of general photos naturally and features smooth gradation. In addition, selecting this setting allows you to adjust colors easily using an application software.

Saturation (Poster)

Reproduces vivid colors on data such as a poster.

No Color Correction

Performs printing without color matching.

▶▶▶ Important

- If **Auto (Use Printer Settings)** is selected for **Media Type**, **Rendering Intent** is grayed out and cannot be set. Colors will be adjusted according to printer settings.

5. Set the other items

From Printer Options, select **Color Options**. If necessary, adjust the color balance (**Cyan**, **Magenta**, **Yellow**) and adjust **Brightness**, and **Contrast** settings.

6. Complete the setup

Click **Print**.

When you execute print, the printer driver adjusts the colors when printing the data.

Related Topics

- ➔ [Setting the Print Quality Level \(Custom\)](#)
- ➔ [Specifying Color Correction](#)
- ➔ [Adjusting Color Balance](#)
- ➔ [Adjusting Brightness](#)
- ➔ [Adjusting Contrast](#)

Printing with ICC Profiles (Specifying an ICC Profile from the Application Software)

When you print from Adobe Photoshop, Canon Digital Photo Professional, or any application software that can identify input ICC profiles and allows you to specify such profiles, printer uses the color management system (ColorSync) built-into macOS when printing. The printer prints the editing and touch-up results of the application software and effectively uses the color space of the input ICC profile specified in the image data.

To use this printing method, use your application software to select color management items and specify an input ICC profile and a printing ICC profile in the image data.

Even if you print using a printing ICC profile that you created yourself, be sure to select color management items from your application software.

For instructions, refer to the manual of the application software you are using.

1. Select **Color Matching** from **Printer Options** in the [Print Dialog](#)

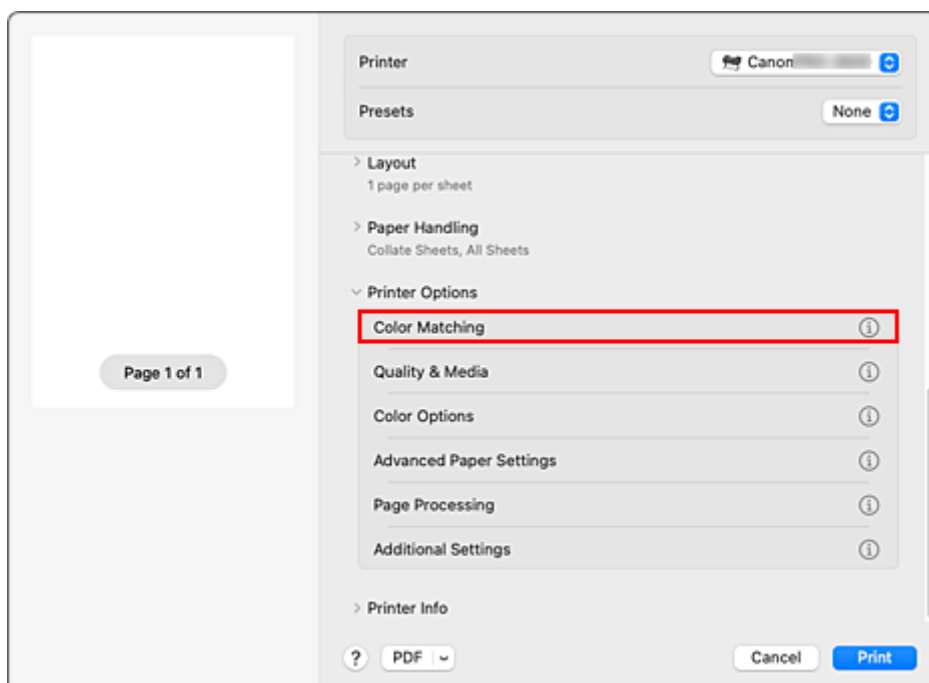

2. Select color correction

Select **ColorSync**.

You can leave **Profile** set to **Automatic**.

»» Important

- Depending on the application software you use, you may not be able to select setting items other than **ColorSync**.
- If you choose a **Profile** setting other than **Automatic** or "Printing Paper ICC Profile", the printer will not be able to print with the correct colors.

3. Complete the setup

Click **Print**.

When you execute print, the printer uses the color space of the image data.

Related Topics

- ➔ [Setting the Print Quality Level \(Custom\)](#)
- ➔ [Specifying Color Correction](#)
- ➔ [Adjusting Color Balance](#)
- ➔ [Adjusting Brightness](#)
- ➔ [Adjusting Contrast](#)

Printing with ICC Profiles (Specifying an ICC Profile from the Printer Driver)

Print from an application software that cannot identify or specify input ICC profiles by using the color space of the input ICC profile (sRGB) found in the data.

1. Select **Color Matching** from **Printer Options** in the [Print Dialog](#)

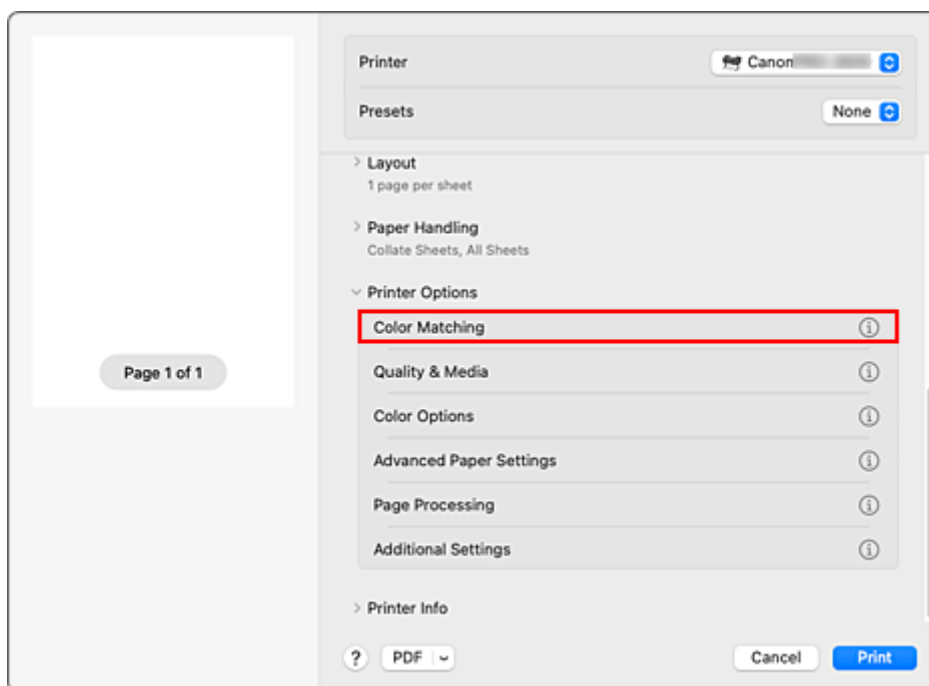

2. Select color correction

Select **ColorSync**.

You can leave **Profile** set to **Automatic**.

»» Important

- If you choose a **Profile** setting other than **Automatic** or "Printing Paper ICC Profile", the printer will not be able to print with the correct colors.

3. Complete the setup

Click **Print**.

When you execute print, the printer uses the color space of the image data.

»» Important

- You cannot specify an input ICC profile from the printer driver.

Related Topics

- ➔ [Setting the Print Quality Level \(Custom\)](#)
- ➔ [Specifying Color Correction](#)
- ➔ [Adjusting Color Balance](#)

- ➔ [Adjusting Brightness](#)
- ➔ [Adjusting Contrast](#)

Adjusting Brightness

You can brighten or darken the colors of the overall image data during printing.

The following sample shows the case when light colors are darkened when the image data is printed.



No adjustment

Darken light colors

The procedure for adjusting brightness is as follows:

1. Select **Color Options** from **Printer Options** in the [Print Dialog](#)

2. Adjust brightness

Moving the **Brightness** slider to the right brightens the colors, and moving the slider to the left darkens the colors.

You can also directly enter a value linked to the slider. Enter a value in the range from -50 to 50. The current settings are displayed in the settings preview on the left side of the printer driver.

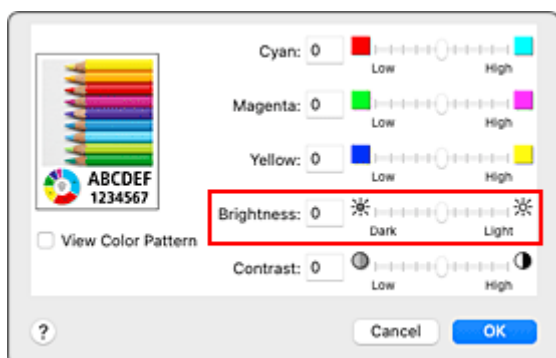

3. Complete the setup

Click **Print**.

When you execute print, the data is printed at the adjusted brightness.

Related Topics

- ➔ [Setting the Print Quality Level \(Custom\)](#)
- ➔ [Specifying Color Correction](#)
- ➔ [Adjusting Color Balance](#)
- ➔ [Adjusting Contrast](#)

Adjusting Contrast

You can adjust the image contrast during printing.

To make the differences between the light and dark portions of images greater and more distinct, increase the contrast. On the other hand, to make the differences between the light and dark portions of images smaller and less distinct, reduce the contrast.



No adjustment

Adjust the contrast

The procedure for adjusting contrast is as follows:

1. Select **Color Options** from **Printer Options** in the [Print Dialog](#)
2. Adjust the contrast

Moving the **Contrast** slider to the right increases the contrast, and moving the slider to the left decreases the contrast.

You can also directly enter a value linked to the slider. Enter a value in the range from -50 to 50. The current settings are displayed in the settings preview on the left side of the printer driver.

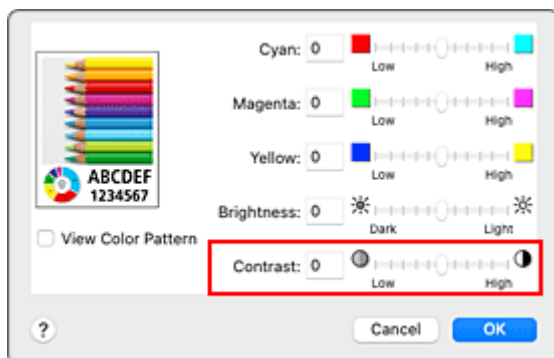

3. Complete the setup

Click **Print**.

When you execute print, the image is printed with the adjusted contrast.

Related Topics

- ➔ [Setting the Print Quality Level \(Custom\)](#)
- ➔ [Specifying Color Correction](#)
- ➔ [Adjusting Color Balance](#)
- ➔ [Adjusting Brightness](#)

Scaled Printing

The procedure for printing a document with pages enlarged or reduced is as follows:

Printing by Enlarging/Reducing Document to Specified Ratio

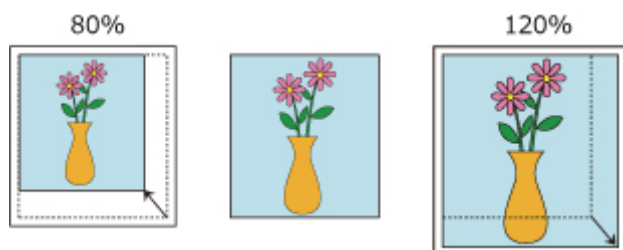

1. Select the printer

In the [Page Setup Dialog](#), select your model name from the **Format For** list.

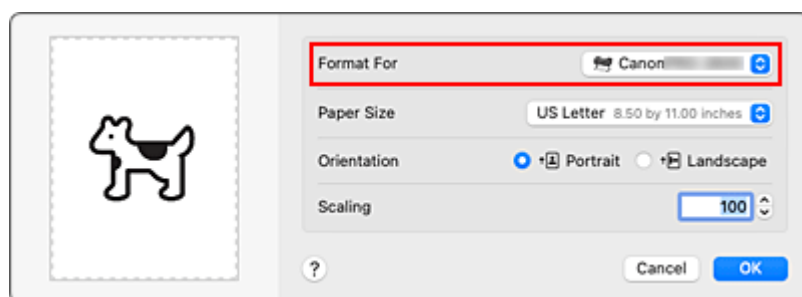

2. Set scaled printing

Specify the scaling factor in the **Scale** box, and click **OK**.

▶▶▶ Note

- Depending on the **Scale** value that you set, an error message may be displayed.

3. Complete the setup

On the [Print Dialog](#), click **Print**.

When you execute print, the document will be printed with the specified scale.

▶▶▶ Important

- When the application software which you used to create the original has the scaled printing function, configure the settings on your application software. You do not need to configure the same setting in the Page Setup dialog.

Printing by Enlarging/Reducing Document to Match Roll Paper Width

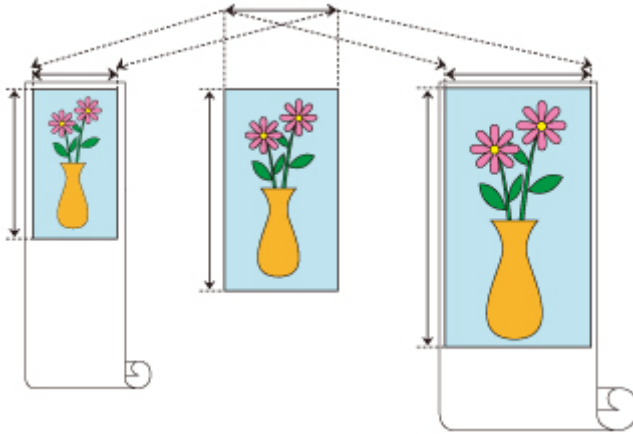

1. Select **Page Processing** from **Printer Options** in the Print Dialog

2. Setting Enlarged/Reduced Printing

For **Fit Roll Paper Width**, select **On (Bordered)** or **On (Borderless)**.

➤➤➤ Note

- Depending on the **Paper Size** settings, the settings you can choose will differ.
- When selecting "XXX oversize" from **Paper Size**, **On (Borderless)** cannot be selected.

3. Complete the setup

Click **Print**.

When you print, the document is expanded or reduced to match the roll paper width and then printed.

Printing to Oversized Paper Sizes

When printing a created document so that it fills the entire paper width, select a paper size from the "XXX oversize" (sizes resulting from adding margins necessary for printer operation to the document sizes) so that all areas of the document are printed at their actual size.

A printout that has the same area as the document can be obtained by trimming the outer margins after printing.

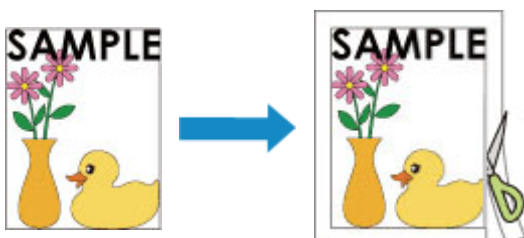

The procedure for printing with oversize is as follows:

1. Select oversized paper size

In the [Print dialog](#), select "XXX oversize" for **Paper Size**.

2. Select **Quality & Media** from **Printer Options**

3. Select the paper source

For **Paper Source**, select the paper source that matches your purpose from **Roll Paper (Auto)**, **Roll 1**, and **Roll 2**.

»» Important

- The paper feed method will differ depending on the lower level (roll paper 2) settings or roll unit option settings.

4. Select **Page Processing** from **Printer Options**

5. Select roll paper width

Set **Roll Paper Width** to the width of the roll paper loaded in the printer.

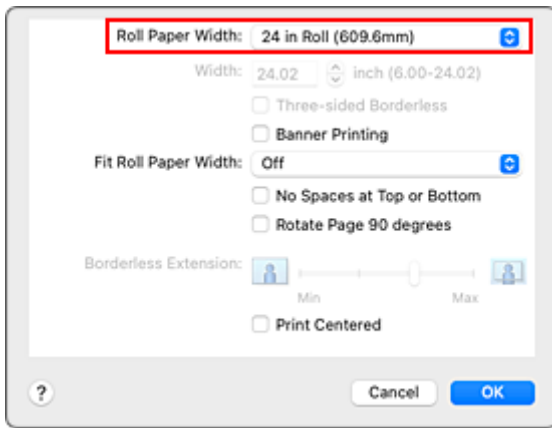

6. Complete the setup

Click **Print**.

When you print, the document is printed so that it fills the paper width.

►► Important

- When printing to oversized paper sizes, use paper that has the following necessary margins added to the document size.
 - Cut sheet: 6 mm or more added to width and 23 mm or more added to height of document size
 - Roll paper: 6 mm or more added to width and 6 mm or more added to height of document size

►► Note

- An oversized paper size cannot be used for the largest paper size that can be loaded in the printer.

Setting Paper Dimensions (Custom Size)

You can specify the height and width of paper when its size cannot be selected from the **Paper Size** menu. Such a paper size is called "custom size."

The procedure for specifying a custom size is as follows:

1. Creating a new custom paper size

In the [Print Dialog](#), select **Manage Custom Sizes...** from **Paper Size**.

In the displayed dialog, click **+**.

Untitled will be added to the list.

2. Setting details about the custom paper size

Double-click **Untitled**, enter the name of the paper size you want to register, and specify the **Width** and **Height** of the paper for **Paper Size**.

Select **User Defined** or your model for **Margins**.

3. Registering the custom paper size

Click **OK**.

The custom size is registered.

▶▶ Important

- If the application software that created the document has a function for specifying height and width values, use the application software to set the values. If the application software does not have such a function or if the document does not print correctly, perform the above procedure from the printer driver to set the values.

▶▶ Note

- To duplicate the registered paper size, select the paper size that you want to duplicate from the **Custom Paper Sizes** list, and click **Duplicate**.
- To delete a registered paper size, select the paper size that you want to delete from the **Custom Paper Sizes** list, and click **-**.
- If the paper settings in the printer driver differ from the paper information registered on the printer, an error message may appear on the printer's operation panel. You can still print but you may not be able to obtain correct print results.

Set a Custom Size Roll Width

By specifying the roll paper width with a value, you can use roll paper with a width that cannot be selected in **Roll Paper Width**.

The procedure for setting custom size roll width is described below.

1. Select **Quality & Media** from **Printer Options** in the [Print Dialog](#)
2. Select the paper source

Select **Roll Paper (Auto)**, **Roll 1**, or **Roll 2** that matches your purpose for **Paper Source**.

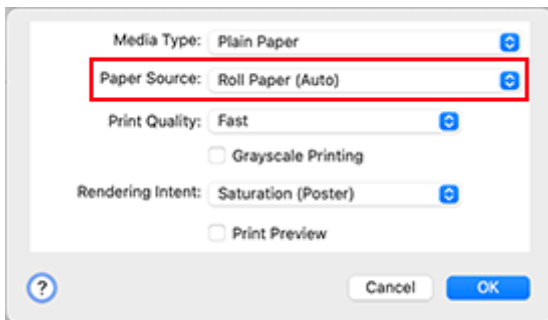

3. Select **Page Processing** from **Printer Options**
4. Select paper roll width

Select **Custom Size** for **Roll Paper Width**.

5. Set paper roll width

Enter the roll width you want to use for **Width**.

6. Complete the setup

Click **Print**.

If you perform the print, the roll paper with the specified width will be used for printing.

Printing without Edges Based on the Scenarios

- **Printing without Margins to Match Roll Paper Width**
- **Printing Full-Size without Margins**
- **Three-sided Borderless Printing on Roll Paper**

Printing without Margins to Match Roll Paper Width

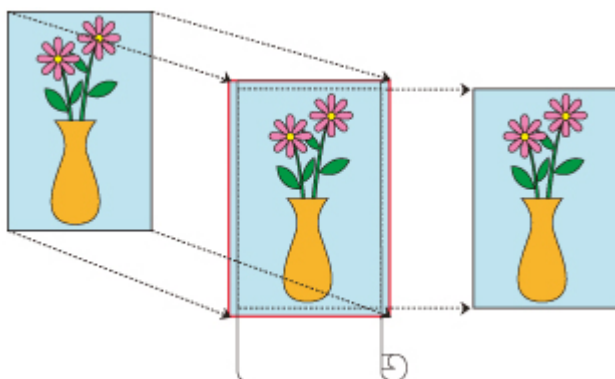

Procedure for printing borderless by enlarging/reducing documents to match roll paper width.

1. Select the paper size for whole-surface borderless printing

Select "XXX Borderless" from **Paper Size** in the [print dialog](#).

2. Select **Page Processing from **Printer Options****

3. Select roll paper width

For paper roll width, enter the same value set in the printer under **Roll Paper Width**.

4. Select a method for printing on roll paper

In **Fit Roll Paper Width**, select **On (Borderless)**.

5. Complete setting process

Click **Print**.

If you print now, the document will be printed by filling in the entire surface of the paper.

»» Important

- If you want to print borderless using a custom paper size, create a custom paper size by choosing **Paper Size, Manage Custom Sizes...**, and setting all **Margins** values to 0 mm. Next, choose **Page Processing, Fit Roll Paper Width** and select **On (Borderless)**.
- If you try to set borderless printing, in **Page Processing, Banner Printing** and **Print Centered** will be displayed in gray and you will not be able to configure them.
- Depending on paper size, the length/width ratio of the paper may be different from that of the image, making it impossible for the whole image to fit on the paper.
When this happens, crop the image with the application software to match paper size.
- When printing borderless, printing may stop abruptly and the paper will be cut causing a slight color unevenness on the edges of the paper. If you require particularly high quality, go to **Automatic Cutting** under **Advanced Paper Settings**, and select **None**. When you do so, the document will be printed without the left and right margins. After the printed material has exited the printer and has been cut, cut the upper and lower edges with a pair of scissors.

- When printing borderless on paper with low ink-fixing properties, depending on frequency of use, the cutter unit may come into contact with the paper surface scratching it and causing the paper to be unevenly cut.

You may be able to improve the situation by choosing **Advanced Paper Settings** and set **Dry Time (Between Pages)** to a higher value.

- The following roll paper supports borderless printing.

➔ [Paper Sizes](#)

- If margins are formed on the left and right of the document, adjust the amount extending off paper during borderless printing from operation panel of the printer.

See "[Borders appear in borderless printing](#)" for details on how to set the amount extending off paper.

▶▶ Note

- When using applications that allow you to set margins, set margins to 0 mm.

Printing Full-Size without Margins

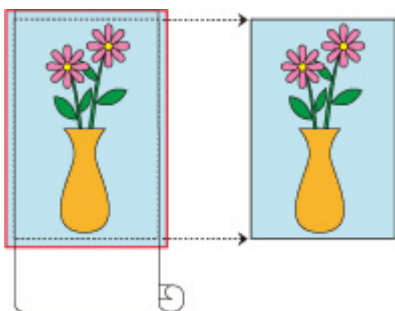

Procedure for printing borderless images in the same size as the original document without enlarging/reducing them

1. Select the paper size for whole-surface borderless printing

Select "XXX Borderless" from **Paper Size** in the [print dialog](#).

2. Select **Page Processing from **Printer Options****

3. Select roll paper width

For paper roll width, enter the same value set in the printer under **Roll Paper Width**.

4. Select a method for printing on roll paper

For **Fit Roll Paper Width**, select **Off**.

»» Important

- Depending on **Paper Size**, when setting **Fit Roll Paper Width** on **Off**, it may not be possible to print borderless.

5. Complete setting process

Click **Print**.

If you print now, the document will be printed by filling in the entire surface of the paper.

»» Important

- If you try to set borderless printing, in **Page Processing**, **Banner Printing** and **Print Centered** will be displayed in gray and you will not be able to configure them.
- Depending on paper size, the length/width ratio of the paper may be different from that of the image, making it impossible for the whole image to fit on the paper.
When this happens, crop the image with the application software to match paper size.
- When printing borderless, printing may stop abruptly and the paper will be cut causing a slight color unevenness on the edges of the paper. If you require particularly high quality, go to **Automatic Cutting** under **Advanced Paper Settings**, and select **None**. When you do so, the document will be printed without the left and right margins. After the printed material has exited the printer and has been cut, cut the upper and lower edges with a pair of scissors.

- When printing borderless on paper with low ink-fixing properties, depending on frequency of use, the cutter unit may come into contact with the paper surface scratching it and causing the paper to be unevenly cut.

You may be able to improve the situation by choosing **Advanced Paper Settings** and set **Dry Time (Between Pages)** to a higher value.

- The following roll paper supports borderless printing.

➔ [Paper Sizes](#)

- If margins are formed on the left and right of the document, adjust the amount extending off paper during borderless printing from operation panel of the printer.

See "[Borders appear in borderless printing](#)" for details on how to set the amount extending off paper.

▶▶ Note

- When using applications that allow you to set margins, set margins to 0 mm.

Three-sided Borderless Printing on Roll Paper

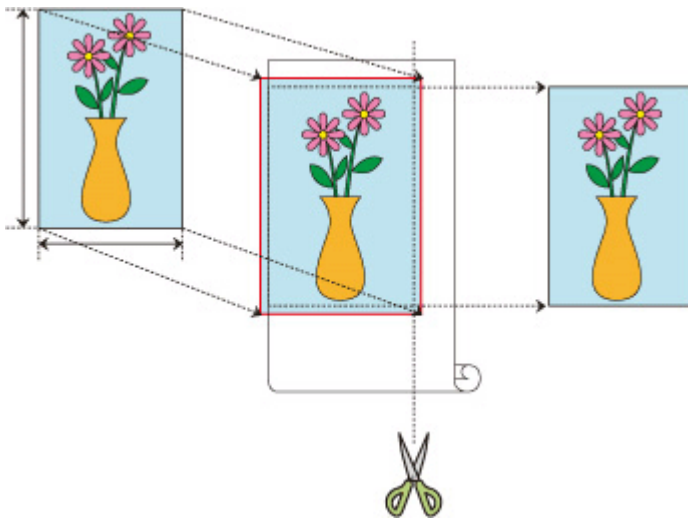

With the three-sided borderless printing feature, you can print with no borders on three sides if the paper sizes don't match the roll paper width.

You can complete borderless printing by cutting the right side of the paper after printing.

Three-sided Borderless Printing to Match Paper Size

The procedure for three-sided borderless printing by enlarging or reducing documents to match paper size is described below.

1. Select the paper size for whole-surface borderless printing
Select "XXX Borderless" from **Paper Size** in the [print dialog](#).
2. Select **Paper Handling**
3. Turn on **Scale to Fit Paper Size**
4. Select paper size
Select "XXX Borderless" in **Destination Paper Size**.
5. Select **Page Processing** from **Printer Options**
6. Select roll paper width
For paper roll width, enter the same value set in the printer under **Roll Paper Width**.
7. Place a checkmark next to **Three-sided Borderless**

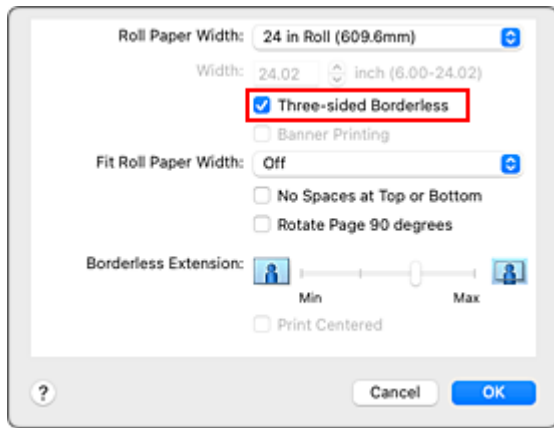

8. Complete setting process

Click **Print**.

If you print now, the document will be printed without margins on three sides to fit the paper size.

9. Cut the right side of the paper

Cut the margin on the right side of the paper with scissors after printing.

Cut slightly to the inside of the margin as the document is enlarged to extend slightly beyond the specified size.

To get the document to standard size, it is recommended to take measurements and cut in the correct positions.

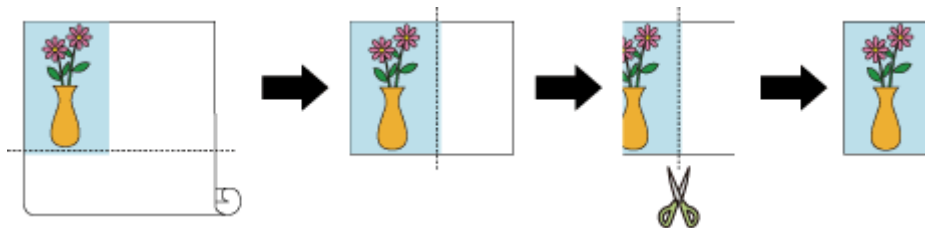

Printing Full-Size without Margins on Three Sides

The procedure for three-sided borderless printing in the same size as the original document without enlarging or reducing the size is described below.

1. Select the paper size for whole-surface borderless printing

Select "XXX Borderless" from **Paper Size** in the [print dialog](#).

2. Select **Page Processing** from **Printer Options**

3. Select roll paper width

For paper roll width, enter the same value set in the printer under **Roll Paper Width**.

4. Place a checkmark next to **Three-sided Borderless**

5. Select a method for printing on roll paper

For **Fit Roll Paper Width**, select **Off**.

6. Complete setting process

Click **Print**.

If you print now, the document will be printed without margins on three sides while retaining the same document size.

7. Cut the right side of the paper

Cut the margin on the right side of the paper with scissors after printing.

To get the document to standard size, it is recommended to take measurements and cut in the correct positions.

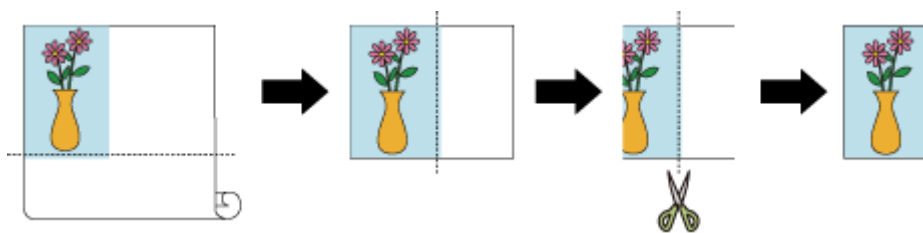

►► Important

- If you try to set borderless printing, in **Page Processing**, **Banner Printing** and **Print Centered** will be displayed in gray and you will not be able to configure them.
- Depending on paper size, the length/width ratio of the paper may be different from that of the image, making it impossible for the whole image to fit on the paper.
When this happens, crop the image with the application software to match paper size.
- When printing borderless, printing may stop abruptly and the paper will be cut causing a slight color unevenness on the edges of the paper. If you require particularly high quality, go to **Automatic Cutting** under **Advanced Paper Settings**, and select **None**. When you do so, the document will be printed without the left and right margins. After the printed material has exited the printer and has been cut, cut the upper, lower, and right edges with a pair of scissors.
- When printing borderless on paper with low ink-fixing properties, depending on frequency of use, the cutter unit may come into contact with the paper surface scratching it and causing the paper to be unevenly cut.
You may be able to improve the situation by choosing **Advanced Paper Settings** and set **Dry Time (Between Pages)** to a higher value.
- The following roll paper supports borderless printing.
➔ [Paper Sizes](#)
- If margins are formed on the left of the document, adjust the amount extending off paper during borderless printing from operation panel of the printer.
See "[Borders appear in borderless printing](#)" for details on how to set the amount extending off paper.

»» Note

- When using applications that allow you to set margins, set margins to 0 mm.

Printing Hanging and Horizontal Banners (Large-Format Printing)

A drapery or banner up to 18.0m can be made by enlarging or reducing original documents made on application software.

The procedure for printing hanging and horizontal banners is as follows:

1. Register custom paper size

From **Paper Size**, use **Manage Custom Sizes...** to [register the paper size](#) that you want to use.

2. Select the paper size

In the [Print dialog](#), select a registered custom paper size from the **Paper Size** list.

3. Select **Page Processing from **Printer Options****

4. Select roll paper width

Set **Roll Paper Width** to the width of the roll paper loaded in the printer.

5. Selecting **On (Bordered) or **On (Borderless)** for **Fit Roll Paper Width****

»» Important

- When using the customer paper size and printing the whole sheet without edges, create a paper size with the **Margins** values all set to 0mm in **Manage Custom Sizes...** from **Paper Size**, and select **On (Borderless)** from the **Fit Roll Paper Width** in **Page Processing**.

6. Complete the setup

Click **Print**.

When you print, the hanging or horizontal banner is printed by using the custom paper size.

»» Note

- Maximum printable length is 18.0 m. In the event the enlarged length exceeds 18.0 m, the entire document is shrunk so that it fits before being printed.

Printing by Dividing/Joining Documents

- **Lining Up and Printing Multiple Documents**
- **Printing by Connecting Multiple Pages**
- **Printing Multiple Pages All on One Page**

Lining Up and Printing Multiple Documents

You can line up multiple documents that were created separately and print them together on one page.

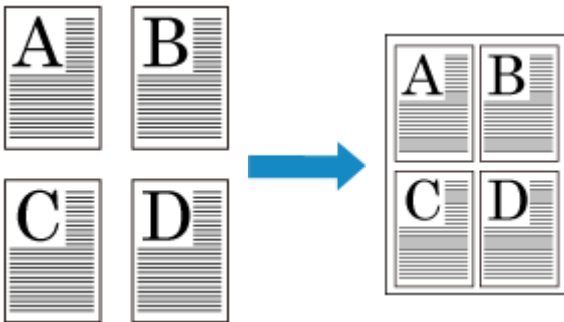

The procedure for lining up and printing multiple documents is as follows:

1. In [Print dialog](#), select Canon imagePROGRAF Free Layout for **PDF**

Canon imagePROGRAF Free Layout is started.

Canon imagePROGRAF Free Layout allows you to edit and rearrange images.

2. Execute printing

From the **File** menu of Canon imagePROGRAF Free Layout, select **Print...** to execute printing.

Printing by Connecting Multiple Pages

Print documents with several pages as one continuous document. When you do this, the spaces between the pages will be removed.

The procedure for printing by connecting multiple pages is as follows:

1. Select **Quality & Media** from **Printer Options** in the [Print Dialog](#)

2. Select the paper source

Select **Roll Paper (Auto)**, **Roll 1** or **Roll 2** that matches your purpose for **Paper Source**.

▶▶▶ Important

- The paper feed method will differ depending on the lower level (roll paper 2) settings or roll unit option settings.

3. Select **Page Processing** from **Printer Options**

4. Setting Banner Printing

Check the **Banner Printing** check box.

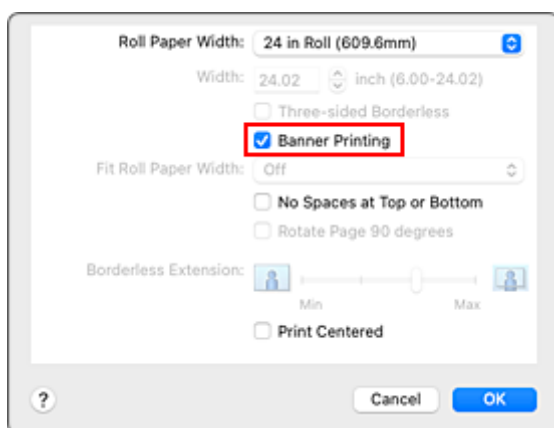

5. Complete the setup

Click **Print**.

When you print, the document is printed with the multiple pages connected.

▶▶▶ Important

- When "XXX Borderless" or "XXX Cut Sheet" is selected for **Paper Size** in the Print dialog, **Banner Printing** is grayed out and cannot be set.

Printing Multiple Pages All on One Page

The page layout printing function allows you to print more than one page image on a single sheet of paper.



The procedure for performing page layout printing is as follows:

1. Select **Layout** in the [Print Dialog](#)

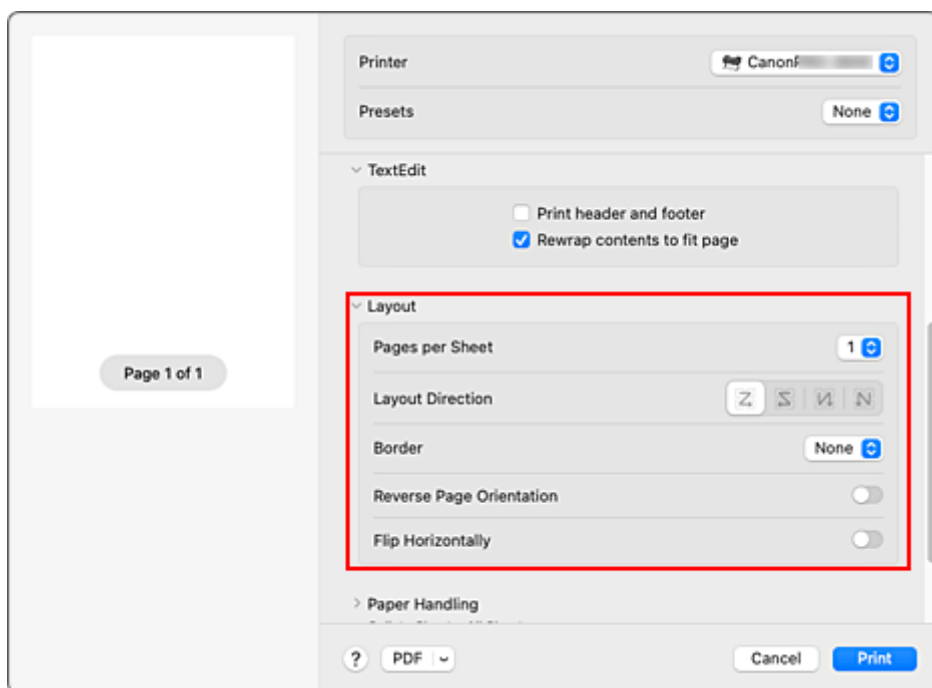

2. Set the number of original you print on one page

In **Pages per Sheet**, specify the number of page you print on one page.

3. If necessary, set the following items

Layout Direction

To change the page placement order, select an icon from the list.

Border

To print a page border around each document page, select a type of page border.

Reverse page orientation

Turn this on to change the paper orientation.

Flip horizontally

Turn this on to reverse left and right of the document.

4. Complete the setup

Click **Print**.

When you execute print, the specified number of pages will be arranged on each sheet of paper in the specified order.

Printing Document in Center of Paper

When you want to position the source document in the middle of the cut sheet and print, or print with even margins on the right and left in relation to the width of the roll paper, use the **Print Centered** function.

The print results when setting with **Print Centered** are as follows. Normally, if **Print Centered** is set when printed as in (A), it will be printed as in (B) for cut sheet and (C) for roll paper.

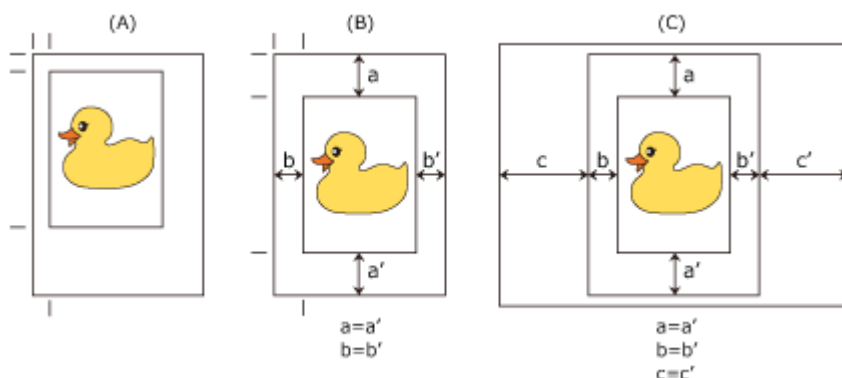

►►► Note

- When setting the magnification using **Scale** in the [Page Setup Dialog](#), a fixed point at the upper left corner of a page is always used as a start point for enlarging or reducing the page. For that reason, when performing reduced printing, the bottom and right margins of the paper will increase. At this time, if you place a checkmark next to **Print Centered**, the top, bottom, left and right margins can all be printed evenly.

The procedure for printing to the center of the paper is as follows:

1. Select the paper size

From **Paper Size**, select the size of the paper you want to print.

2. Select **Quality & Media** from **Printer Options**

3. Select the media type

For **Media Type**, select the same paper type loaded in the printer.

If **Auto (Use Printer Settings)** is selected, the paper configured in printer settings is printed.

4. Select the paper source

For **Paper Source**, select the setting that matches your purpose.

►►► Important

- The paper feed method will differ depending on the lower level (roll paper 2) settings or roll unit option settings.

5. Select **Page Processing** from **Printer Options**

6. Selecting Roll Paper Width

If you selected a roll paper for **Paper Source**, set **Roll Paper Width** to the width of the roll paper loaded in the printer.

7. Print document in the center of paper

Check the **Print Centered** check box.

8. Complete the setup

Click **Print**.

When you print, the printer automatically lays out the document to the center of the page and then prints it.

Important

- When you select "XXX Borderless" from **Paper Size** in the print dialog, the **Print Centered** is grayed out and cannot be selected.

Printing by Saving Roll Paper

- **Saving Roll Paper by Rotating Document 90 Degrees**
- **Saving Roll Paper by Eliminating Upper and Lower Margins on Document**

Saving Roll Paper by Rotating Document 90 Degrees

When printing a portrait document on roll paper, you can save paper by rotating the document 90 degrees and printing the document so that it is oriented horizontally relative to the paper.

The procedure for saving paper by rotating the document 90 degrees is as follows:

1. Select **Page Processing** from **Printer Options** in the [Print Dialog](#)

2. Selecting Paper Saving

Select the **Rotate Page 90 degrees** check box.

3. Complete the setup

Click **Print**.

When you print, you can rotate a portrait document 90 degrees to save paper.

»» Important

- If the **Banner Printing** check box is selected for **Page Processing**, **Rotate Page 90 degrees** is grayed out and cannot be set.
- When selecting paper in portrait format from **Paper Size** in the print dialog, when this is longer than the width selected in **Roll Paper Width**, **Rotate Page 90 degrees** cannot be used.

Saving Roll Paper by Eliminating Upper and Lower Margins on Document

When printing on roll paper, you can save paper by reducing the upper and lower margins when printing.

The procedure for saving paper by reducing the upper and lower margins is as follows:

1. Select **Quality & Media** from **Printer Options** in the [Print Dialog](#)

2. Select the paper source

Select **Roll Paper (Auto)**, **Roll 1**, or **Roll 2** that matches your purpose for **Paper Source**.

»» Important

- The paper feed method will differ depending on the lower level (roll paper 2) settings or roll unit option settings.

3. Select **Page Processing** from **Printer Options**

4. Selecting Paper Saving

Check the **No Spaces at Top or Bottom** check box.

5. Complete the setup

Click **Print**.

When you print, the upper and lower margins are reduced so that you can save paper.

Switching the Paper Source to Match the Purpose

This printer has three paper sources: Roll 1, Roll 2, and Cut Sheet.

You can facilitate printing by selecting a paper source setting that matches your media type or purpose.

The procedure for setting paper source is as follows:

1. Select **Quality & Media** from **Printer Options** in the [Print Dialog](#)

2. Select the media type

For **Media Type**, select the same paper type loaded in the printer.

If **Auto (Use Printer Settings)** is selected, the paper configured in printer settings is printed.

3. Select the paper source

For **Paper Source**, select the item below that matches your purpose.

Roll Paper (Auto)

Feeds paper by automatically switching between Roll 1 and Roll 2 according to the print job.

Roll 1

Feeds paper from Roll 1.

Roll 2

Feeds paper from Roll 2.

Cut Sheet

Feeds paper using the cut sheet.

Important

- The paper feed method will differ depending on the lower level (roll paper 2) settings or roll unit option settings.

4. Complete the setup

Click **Print**.

When you execute print, the printer uses the specified paper source to print the data.

Note

- If the paper settings in the printer driver differ from the paper information registered on the printer, an error message may appear on the printer's operation panel. You can still print but you may not be able to obtain correct print results.

Cutting Roll Paper after Printing

The procedure for cutting roll paper automatically and printing cut guidelines is as follows:

1. Select **Advanced Paper Settings** from **Printer Options** in the [Print Dialog](#)

2. Setting Auto Cut

From **Automatic Cutting**, select the setting that matches your purpose.

Yes

The roll paper is cut automatically after printing.

None

The roll paper is not cut after printing.

Print Cut Guideline

Cut guidelines are printed for cutting the roll paper manually after printing.

»» Note

- The default setting for automatic cutting is **Yes**.

3. Complete the setup

Click **Print**.

When you print, the status after printing is set to whatever was set in **Automatic Cutting**.

Printing Using AirPrint

You can print photographs, E-mails, web pages, and other documents using AirPrint, even if the printer driver is not installed or the application is not downloaded.

»» Important

- There are [restrictions](#) for printing with AirPrint. Please be aware in advance. If you want to use all the functions of the printer, use the Canon IJ printer driver.

Checking Your Environment

First, check your environment.

- AirPrint Operation Environment
 - Mac running the latest version of OS
- Requirement
 - The Mac and the printer must be connected by one of the following methods:
 - Connected to the same network over a **LAN**
 - Connected directly without wireless router (Direct Connection)
 - Connected by USB

Add The Printer as AirPrint Printer on Your Mac

1. Open **System Settings** -> **Printers & Scanners**
2. Click **Add Printer, Scanner or Fax...**
3. Select your printer listed as **Bonjour**
4. Select your printer from **Use**
5. Click **Add**

The Printer will be added as AirPrint Printer on Your Mac

Print with AirPrint from a Mac

1. [Check that printer is turned on](#)
2. Load paper in printer
 - Set [roll paper](#) or [cut sheet](#).
3. Start printing from your application software
 - The Print dialog opens.

4. Select printer

Select your model from the **Printer** list in the Print dialog.

5. Check print settings

Set paper size and other items as needed.

Set paper type from the printer.

▶▶▶ Note

- Use the Print dialog to set general print settings such as the layout and the print sequence. For information about print settings, refer to macOS help.
- You can set **Print quality settings**, **Paper settings**, and **Magnification level for borderless** on the operation panel of the printer. For details, see "[Print settings](#)."

6. Click **Print**

The printer prints according to the specified settings.

▶▶▶ Note

- It can take the Wi-Fi a few minutes to get connected after the printer turns on. Print after checking that the printer is connected to the network.
- You cannot use AirPrint if Bonjour settings of printer are disabled. Check **LAN** settings of printer and enable Bonjour settings.
- Refer to "[Cannot Print Using AirPrint](#)" for printing problems when using AirPrint.
- The display of the settings screen may differ depending on the application software you are using.

Deleting Print Job

Use **Stop** button from printer to cancel the print job.

Restrictions on the AirPrint

- If **A2+**, **A3+**, or **13 x 22** is selected for **Paper Size** in the print dialog, part of the image may not fit on the paper.
- If printing cut sheet, the bottom edge of the image may be cut out.
- To perform borderless printing, configure settings in paper sizes. Depending on the type of paper, print results might have slight margins on the left and right edges.
- If printing cut sheet, feed the paper vertically. If the paper is fed horizontally, it will still print vertical images.
- When printing images with large data sizes, the color may turn out uneven. In this case, select **Printer settings** -> **Hard disk settings** -> **Save first and print** -> **ON** on the operational panel of the printer.
- Some paper sizes that are compatible with the Canon IJ printer driver are not compatible with AirPrint. If using these sizes, set a custom size.
- Canon imagePROGRAF Free Layout and Canon imagePROGRAF Preview cannot be used.

Caution when Setting the Print Quality

If you are using the Canon IJ printer driver or AirPrint, the print quality settings may differ depending on the type of paper you are printing. Excluding some types of paper, **Standard** for Canon IJ printer driver corresponds to **Draft** in AirPrint, and **High** in Canon IJ printer driver corresponds to **Standard** in AirPrint.

Printing from Printer

- **Printing Data Saved on USB Flash Drive**

Printing Data Saved on USB Flash Drive

You can print photo data (JPEG file) or document data (PDF file) saved on the USB flash drive easily.

▶▶▶ Note

- Restrictions on printable PDF/JPEG files

- PDF file:

Files which conforms to V 1.7

-Does not support overprint or some of transparent processing.

-Font embedding is recommended. If a font is not embedded, it is replaced with one of the built-in fonts below.

Times-Roman, Helvetica, Courier, Symbol, Times-Bold, Helvetica-Bold, Courier-Bold, ZapfDingbats, Times-Italic, Helvetica-Oblique, Courier-Oblique, Times-BoldItalic, Helvetica-BoldOblique, Courier-BoldOblique

- JPEG file:

Files which conforms to JFIF 1.02

Supports the files with the following conditions.

-Processing method: Basic DCT

-Color mode: RGB/GrayScale

-Number of colors: 24bit/8bit

-Number of pixels: 38400 or less vertically and horizontally

Does not support some samplings

1. Load paper.

- ➔ [Loading Rolls in the Printer](#)
- ➔ [Loading Roll Paper in the Roll Unit](#)
- ➔ [Loading Sheets in the Printer](#)

2. Insert USB flash drive into the USB flash drive connector.

3. Select Print from USB flash drive on HOME screen.

▶▶▶ Note

- When the message informing you that the operation restriction is enabled, ask the administrator of the printer you are using.
- If no printable data is saved on the USB flash drive, **There are no files that can be printed.** is displayed on the touch screen.

4. Select folder or data to print.

The print standby screen is displayed.

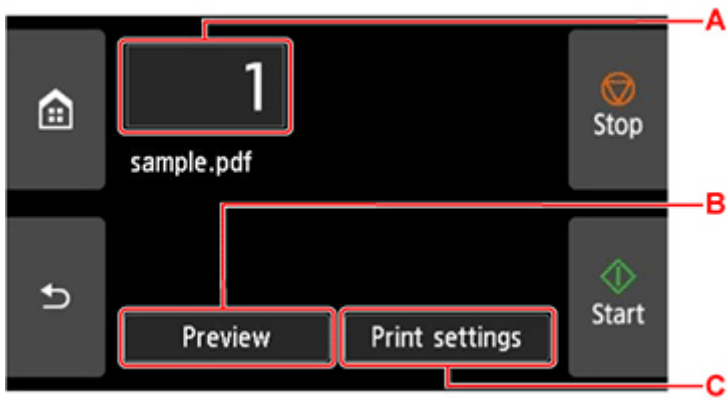

A. Number of copies

Select to change the number of copies.



B. Preview

Select to preview an image of the printout on the preview screen.

Specify the pages to preview and print only specific pages.

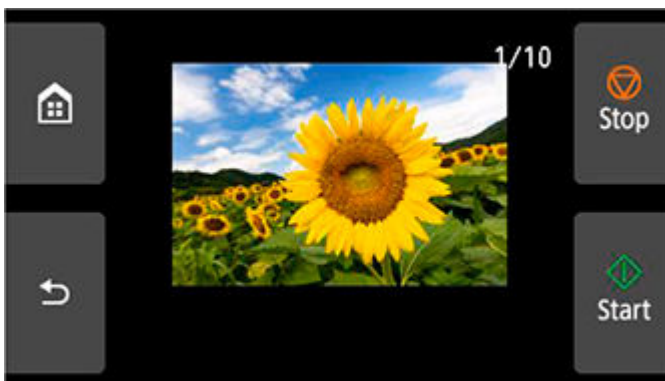

C. Print settings

Select to check or change settings on the **Print settings** screen.

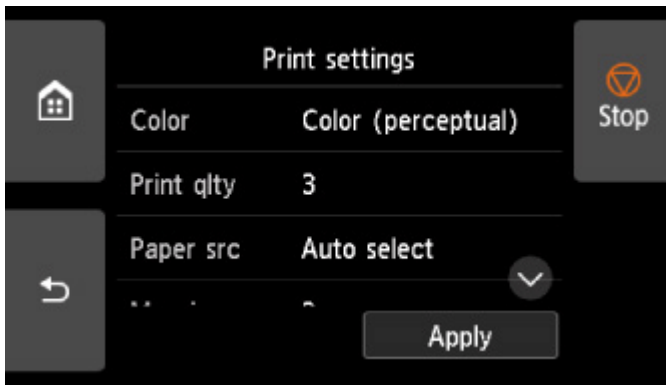

5. Select **Start.**

The printer starts printing.

»» Note

- On the displayed screen, select **Yes** to return to step 4, or select **No** to return to the HOME screen.

Printing from Smartphone/Tablet

For more on printing from a device, refer to the device's or application's instruction manual.

- ▶ **Print Easily from a Smartphone or Tablet with Canon PRINT**
- ▶ **Printing from iOS Device (AirPrint)**

Printing from iOS Device (AirPrint)

Use AirPrint to print photographs, E-mails, web pages, and other documents without having to download special applications.

»» Important

- There are [restrictions](#) for printing with AirPrint. Please be aware in advance.

Checking Your Environment

First, check your environment.

- AirPrint Operation Environment
iPhone, iPad, and iPod touch running the latest version of iOS / iPadOS
- Requirement
The iOS device and the printer must be connected by one of the following methods:
 - Connected to the same network over a **LAN**
 - Connected directly without wireless router (Direct Connection)

Printing with AirPrint from iOS Device

1. [Check that printer is turned on](#)
2. Load paper in printer
Set [roll paper](#) or [cut sheet](#).
3. Tap operation icon using your iOS device's application

The following screen appears when printing from iOS 12's Safari. The screen differs depending on the devices or applications.

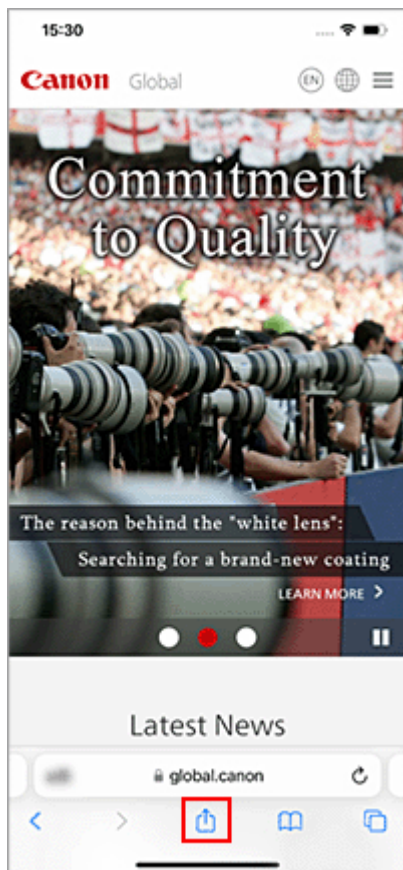

Menu options appear.

4. Tap **Print**

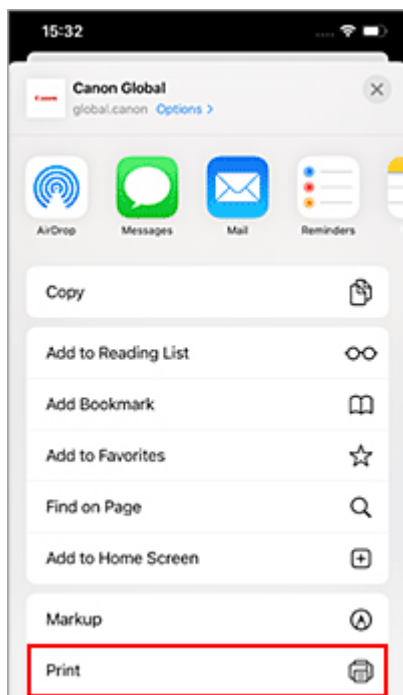

5. Select your model name from **Printer** on **Printer Options**

▶▶▶ Important

- Because some applications do not support AirPrint, **Printer Options** may not be displayed. If an application does not let you use printer options, you cannot print from that application.

6. Check Print Settings

Set the number of copies to be printed and print options, as needed.

7. Tap **Print**

The printer prints according to the specified settings.

▶▶▶ Note

- It can take the Wi-Fi a few minutes to get connected after the printer turns on. Print after checking that the printer is connected to the network.
- You cannot use AirPrint if Bonjour settings of printer are disabled. Check **LAN** settings of printer and enable Bonjour settings.
- Refer to "[Cannot Print Using AirPrint](#)" for printing problems when using AirPrint.

Paper Size

With AirPrint, you can print by selecting the paper set in your printer.

Set the paper in the printer in advance and register the paper type and paper size with AirPrint.

For details on how to register paper, see "[Set roll paper](#)" or "[Set cut sheet](#)."

Checking Print Status

You can check the print status of AirPrint from **Print Center**.

Tap **Print Center** that is displayed in multitasking mode on your iOS device.

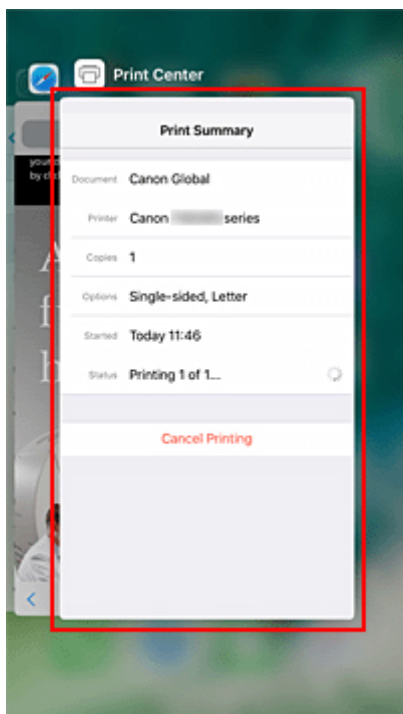

Deleting Print Job

To delete a print job with AirPrint, use one of the following two methods:

- From printer: Use **Stop** button to cancel the print job.
- From iOS device: Tap **Print Center** that is displayed in multitasking mode. In the screen that appears, tap on the print job to be deleted, and then tap **Cancel Printing**.

Restrictions on the AirPrint

- If **A2+**, **A3+**, or **13 x 22** is selected for **Paper Size** in the print dialog, part of the image may not fit on the paper.
- If printing cut sheet, the bottom edge of the image may be cut out.
- If printing cut sheet, feed the paper vertically. If the paper is fed horizontally, it will still print vertical images.
- To perform borderless printing, configure settings in paper sizes. Depending on the type of paper, print results might have slight margins on the left and right edges.
- When printing images with large data sizes, the color may turn out uneven. In this case, select **Printer settings** -> **Hard disk settings** -> **Save first and print** -> **ON** on the operational panel of the printer.

Enlarging Copy with imageRUNNER ADVANCE

Copy scanned with imageRUNNER ADVANCE can be sent to the printer via FTP.

Enable FTP from Remote UI.

1. Start up Remote UI.
➔ [Start up Remote UI](#)
2. Select **System info and LAN settings**.
3. Select **LAN settings**.
4. Select **Advanced setup**.
5. Confirm the message and select **Yes**.
6. Select **FTP settings**.
7. Select **Enable**.
8. Select **Use authentication** check box and **Set/change password** check box, and then enter a user name and password.

The user name and password you enter in this step are used for FTP authentication. Enter the same value for FTP settings of imageRUNNER ADVANCE.
9. Select **OK**.
Please wait momentarily appears and returns to the startup screen.
10. Close web browser.

Perform enlarge settings on the operation panel.

1. Select  **Printer settings** on HOME screen.
2. Select **Print settings**.
3. Select **Direct print settings from FTP**.
4. Select the number to set.

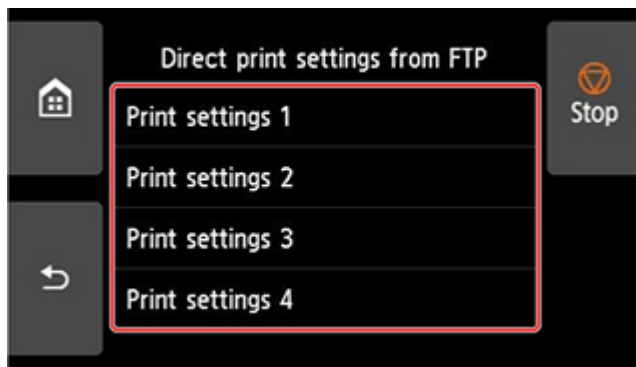

See the following two types of enlargement setting methods.

- ➔ [Fitting to Paper Width](#)
- ➔ [Specifying Magnification Level](#)

Scan and enlarge copy

1. Place the copy on the platen glass or feeder of imageRUNNER ADVANCE.
2. Select **Scan and Send**.

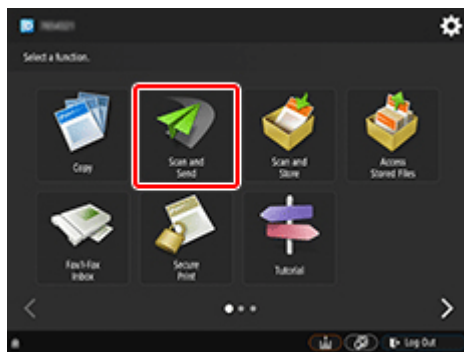

3. Select **New Destination**.

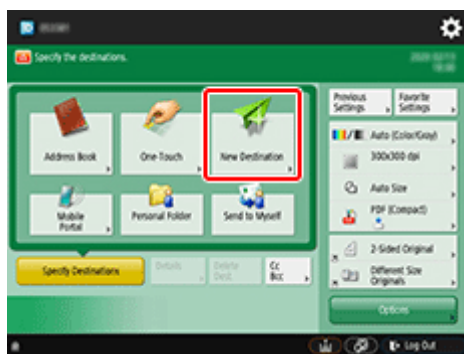

4. Select **File**.

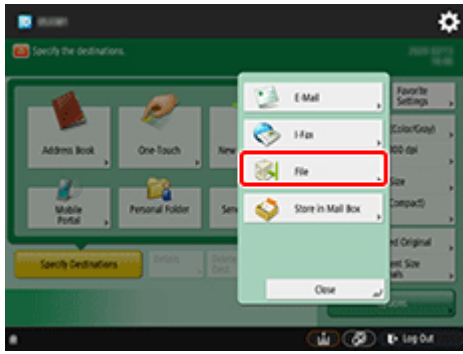

5. Select **FTP** from the **Protocol** drop-down list.

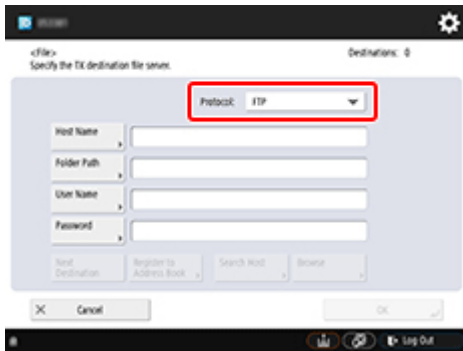

6. Enter setting items.

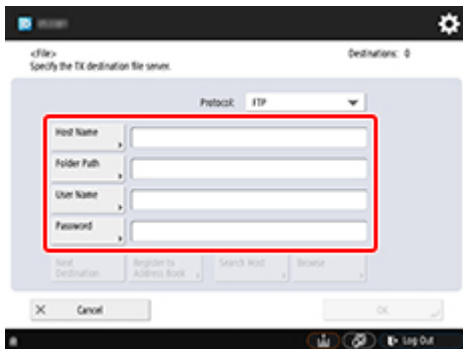

Enter the printer's IP address as the **Host Name**.

➤➤➤ Note

- We recommend that you set a fixed IP address for your printer.

Enter **"/folderN"** in **Folder Path**. ("N" represents the print setting number specified in the **Direct print settings from FTP** screen on the printer.) For example, to enter the pathname for **Print settings 1**, enter **"/folder1"**. For **Print settings 2**, enter **"/folder2"**.

Use the same **User Name** and **Password** that you set for FTP authentication in the Remote UI.

7. Select **OK**.

8. Select the setting button for file format.

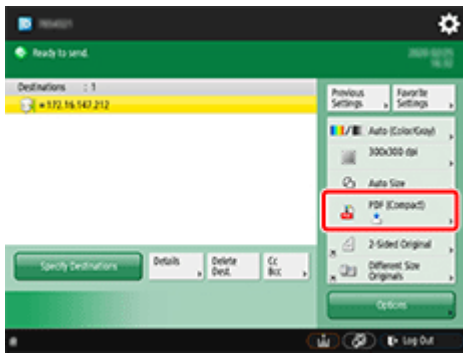

9. Select File Format.

Select **PDF** or **JPEG**.

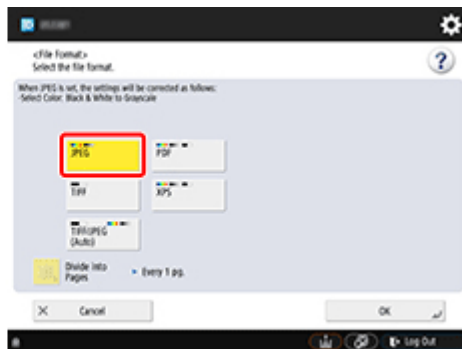
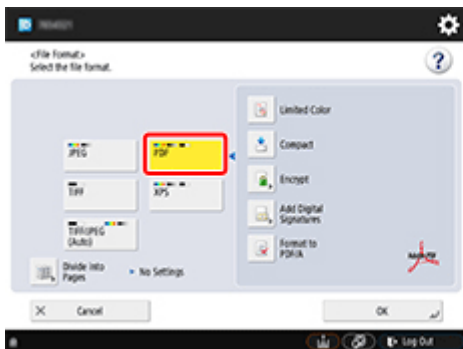

➤➤➤ Note

- If you select **PDF**, remove the check from the **Compact** and **Encrypt** check boxes.

10. Specify the settings as necessary.

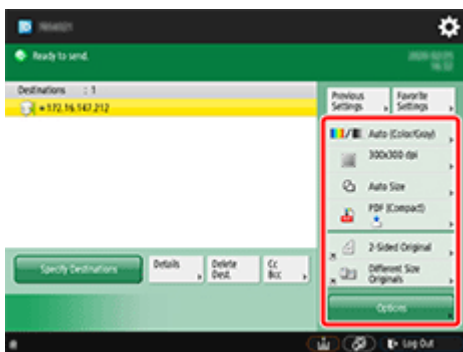

➤➤➤ Important

- Select **300x300 dpi** or **600x600 dpi** as the resolution.

11. Press (Start).

If you are placing your originals on the platen glass, press  (Start) to scan each original.

12. When scanning is complete, select **Start Sending**.

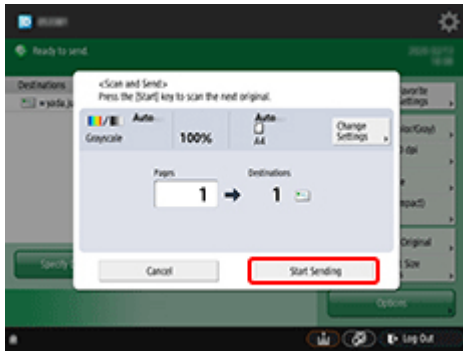

Scanned originals are sent to the printer and printing starts.

➤➤ Note

- It is recommended to register the setting contents in **Favorite Settings**.

Fitting to Paper Width

1. Select **Paper settings**.

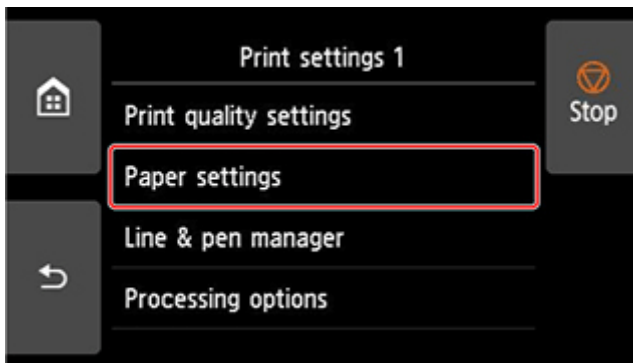

2. Select **Enlarge/Reduce**.

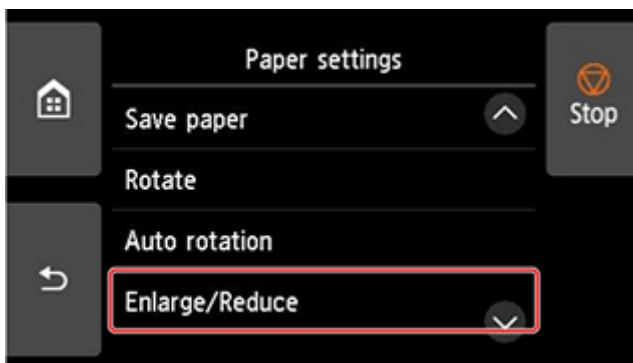

3. Select **Fit paper size**.

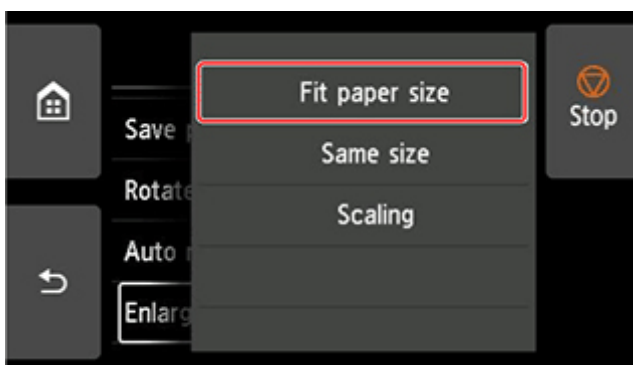

▶▶▶ Note

- Change the image quality in **Print quality settings** if necessary.
- You can specify the orientation of the image from **Rotate**.

Specifying Magnification Level

Setting Input resolution

1. Select **Print quality settings**.

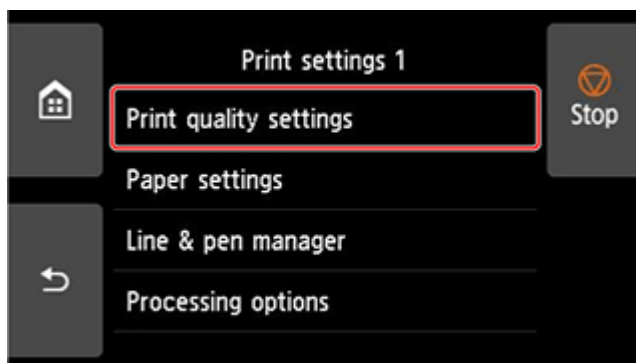

2. Select **Input resolution**.

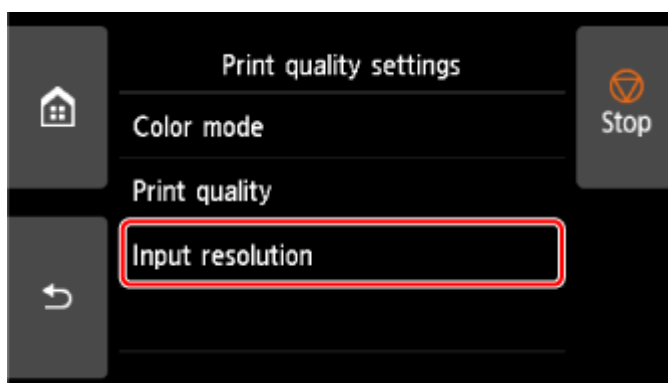

Select the input resolution that matches your output requirements.

600 dpi

Select when printing at 600 dpi.

300 dpi

Select when printing at 300 dpi.

Specify print job

Select to match the input resolution of the printer with the scanning resolution when scanning the original in JPEG format.

»»» Important

- When scanning the original in JPEG format with imageRUNNER ADVANCE, match the scanning resolution with the input resolution of the printer. If the resolution is different, it will not be printed at the specified magnification level.

Setting scale percentage

1. Select **Paper settings**.

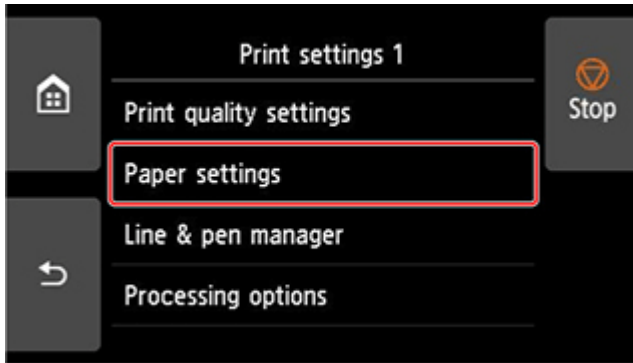

2. Select **Enlarge/Reduce**.

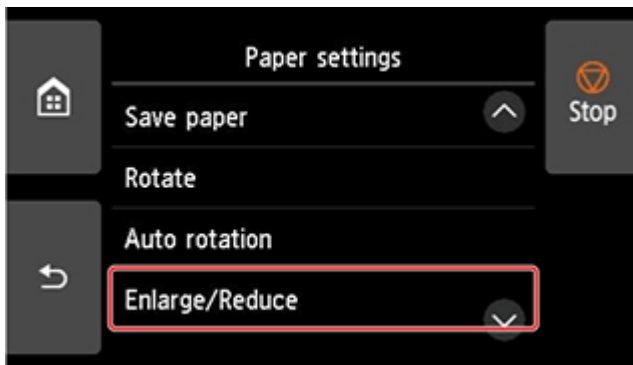

3. Select **Scaling**.

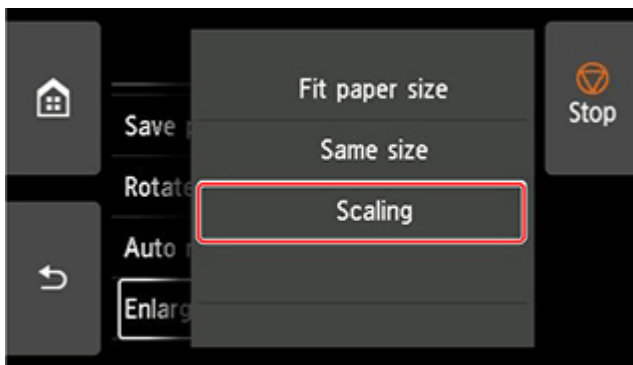

4. Select the scaling input area (A) on the displayed screen.

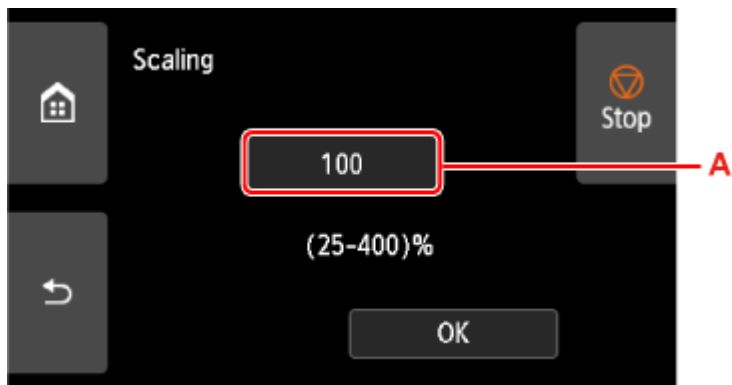

5. Enter the scale percentage, and then select **OK**.

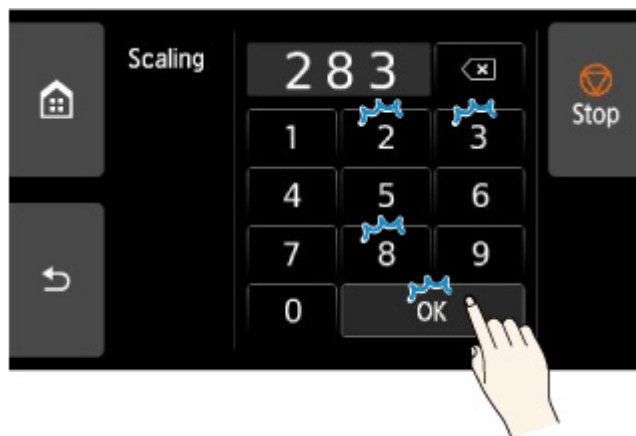

For commonly used magnification conversions, refer to [Reference for Magnification](#).

6. Select **OK** on the displayed screen.

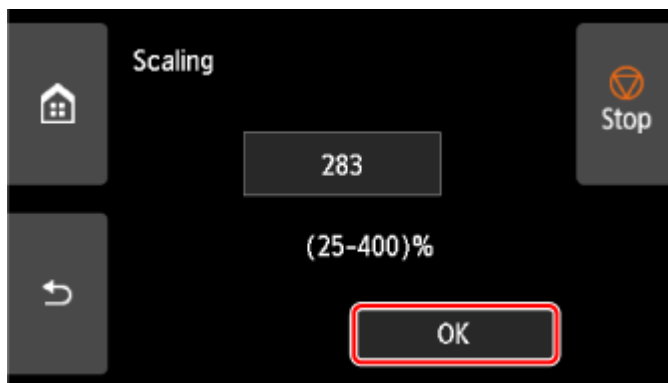

▶▶▶ Note

- Change the image quality in **Print quality settings** if necessary.
- You can specify the orientation of the image from **Rotate**.

Reference for Magnification

- ISO A format

	Original size
--	---------------

		A4	A3
Output size	A4	100%	71%
	A3	141%	100%
	A2	200%	141%
	A1	283%	200%
	A0	400%	283%

- ANSI format

		Original size		
		Letter 8.5" x 11"	Legal 8.5" x 14"	Ledger 11" x 17"
Output size	C	200%	157%	129%
	D	258%	242%	200%
	E	400%	314%	258%

- ARCH format

		Original size	
		A	B
Output size	A	100%	66%
	B	133%	100%
	C	200%	133%
	D	266%	200%
	E	400%	266%
	E1	333%	233%

Managing Print Jobs

➤ Handling Print Jobs

- Deleting Print Jobs
- Priority Printing
- Printing Pending Jobs
- Printing Security Print Jobs

➤ Using the Printer Hard Disk to Handle Print Jobs

- Using Printer Hard Disk
- Saving Print Jobs in Personal Job Boxes
- Printing Saved Jobs
- Deleting Saved Jobs
- Moving Saved Jobs
- Saving Print Jobs Sent from Sources Other than Printer Driver
- Printing without Saving Jobs in Common Job Box
- Setting Passwords for Personal Job Boxes
- Naming Personal Job Boxes
- Printing List of Saved Jobs
- Renaming Saved Jobs
- Printer Hard Disk Operations
- Checking Free Hard Disk Space

➤ Collecting Printer Job Logs Using Accounting Manager

Handling Print Jobs

- **Deleting Print Jobs**
- **Priority Printing**
- **Printing Pending Jobs**
- **Printing Security Print Jobs**

Deleting Print Jobs

You can delete a print job as needed.

This operation is available using the operation panel or Remote UI.

➔ [Using Operation Panel](#)

➔ [Using Remote UI](#)

Using Operation Panel

1. Select  **Job management** on HOME screen.
2. Select **Print job**.
3. In the list, select the target job.

➤➤➤ Note

- Select **Del. selected** to delete multiple jobs at one time.

4. Select **Delete**.

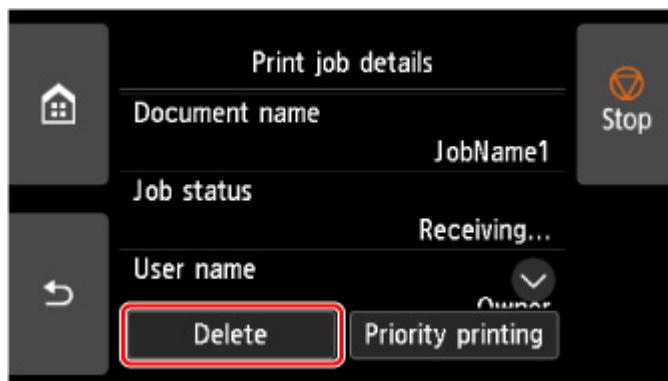

5. Confirm the message and select **Yes**.

➤➤➤ Note

- Select **Delete all print jobs** on **Job management** to delete all jobs in the job queue

➔ [Job management](#)

Using Remote UI

1. Start up Remote UI.
 - ➔ [Start up Remote UI](#)

2. Select **Job management**.
3. Select **Print job**.
4. In the list, select the target job.
5. Select **Delete**.
6. Confirm the message and select **Yes**.

Priority Printing



Specify a print job that is being received to change its print order (Priority printing).

This operation is available using the operation panel or Remote UI.

➔ [Using Operation Panel](#)

➔ [Using Remote UI](#)

▶▶▶ Note

- For the operation of the print job with the  icon (pending print job), see [Printing Pending Jobs](#).
- For the operation of the print job with the  icon (security print job), see [Printing Security Print Jobs](#).

Using Operation Panel

1. Select  **Job management** on HOME screen.
2. Select **Print job**.
3. In the list, select the target job.
4. Select **Priority printing**.

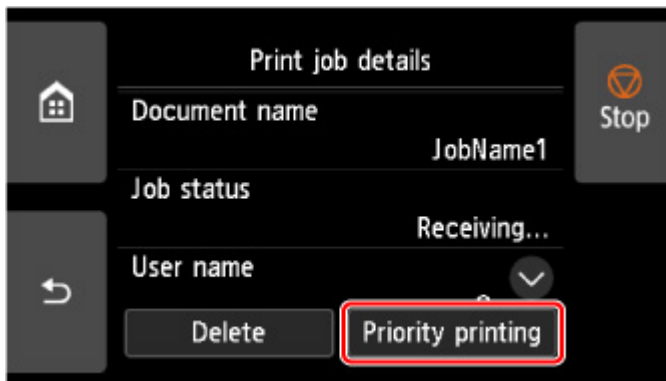

5. Confirm the message and select **Yes**.

Using Remote UI

1. Start up Remote UI.
 - ➔ [Start up Remote UI](#)
2. Select **Job management**.

3. Select **Print job**.
4. In the list, select the target job.
5. Select **Prioritize**.

Printing Pending Jobs

If the type or size of paper loaded does not match the settings in the print job received when you have set **Detect paper setting mismatch** to **Hold job** in the operation panel, the print job is held on the printer as a pending job in the job queue.

To print held jobs, replace the loaded paper with the paper specified in the print job.

- ➔ [Loading Rolls in the Printer](#)
- ➔ [Loading Roll Paper in the Roll Unit](#)
- ➔ [Loading Sheets in the Printer](#)



This operation is available using the operation panel or Remote UI.

- ➔ [Using Operation Panel](#)
- ➔ [Using Remote UI](#)

▶▶▶ Note

- As long as you do not manage held jobs from the operation panel, they will remain in the job queue. In this case, the printer processes the next job in the queue without pausing.

Using Operation Panel

1. Select  **Job management** on HOME screen.
2. Select **Print job**.
3. In the list, select print job with  icon on the left.
4. Select **Release hold**.

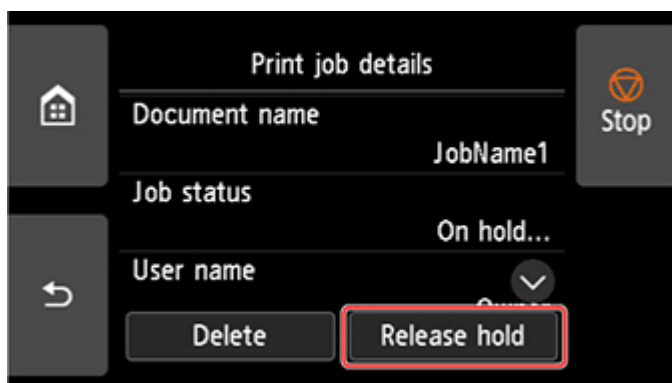

5. Confirm the message and select **Yes**.

Using Remote UI

1. Start up Remote UI.

➡ [Start up Remote UI](#)

2. Select **Job management**.

3. Select **Print job**.

4. In the list, select print job with  icon on the left.

5. Select **Release**.

Printing Security Print Jobs

A security print job is a print job that requires you to enter the PIN code set in the printer driver when printing.

The print job specified for the security print job has a lock icon to the left of the job name in the list such as **List of print jobs**.

▶▶▶ Note

- The security print job remains saved as a normal pending job until you enter the PIN code using the operation panel or Remote UI. In this case, the printer processes the next job in the queue without pausing.
- When deleting a security print job, you do not need to enter a PIN code.

1. Select  **Job management** on HOME screen.

2. Select **Print job**.

3. In the list, select print job with  icon on the left.

4. Select **Print**.

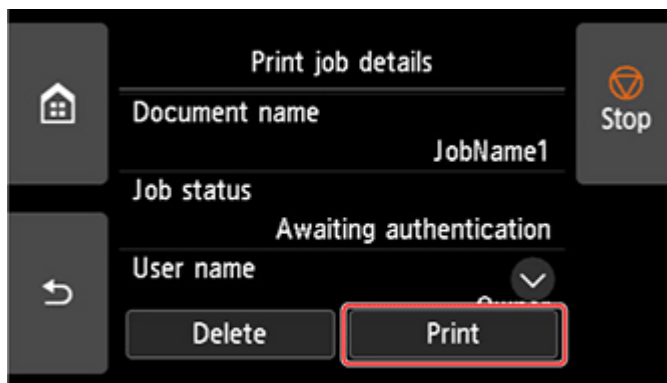

5. Enter PIN code you set and select **OK**.

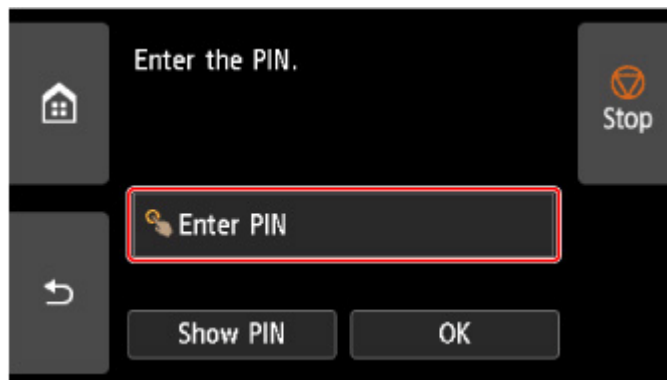

6. Select **OK**.

PIN authentication successful. is displayed and printing starts.

▶▶ Note

- The security print job is deleted after printing.

Using the Printer Hard Disk to Handle Print Jobs

- **Using Printer Hard Disk**
- **Saving Print Jobs in Personal Job Boxes**
- **Printing Saved Jobs**
- **Deleting Saved Jobs**
- **Moving Saved Jobs**
- **Saving Print Jobs Sent from Sources Other than Printer Driver**
- **Printing without Saving Jobs in Common Job Box**
- **Setting Passwords for Personal Job Boxes**
- **Naming Personal Job Boxes**
- **Printing List of Saved Jobs**
- **Renaming Saved Jobs**
- **Printer Hard Disk Operations**
- **Checking Free Hard Disk Space**

Using Printer Hard Disk

The printer can save print jobs on the built-in hard disk.

Saving print jobs offers the following benefits.

- **Save the time spent using a computer**

When you send a print job to the printer, you can save it on the printer after printing or simply save it on the printer without printing it yet. Saved print jobs can be printed in the required quantity later without the need to use a computer again.

- **Simplify reprinting, if any errors occur**

If errors occur in the middle of printing (as when paper runs out), you can resume printing after clearing the error without resending the print job from a computer.

- **Streamline printing work**

Without using a computer, you can select print jobs and print in the desired quantity. You can also select multiple print jobs to print during the same period. This enables unattended operation at night, for example.

Output Method

To save print jobs on the printer's hard disk, configure the printer driver.

In Windows, this is set using the **Output Method** dialog box.

In macOS, this is set by selecting **Additional Settings** in **Printer Options** of the printer properties dialog.

Print

Perform printing while saving the print job on the temporary storage area of the printer's hard disk.

Set PIN for printing

Set a 7 digit security code. To start printing, enter the PIN set here using the operation panel. If the entered PIN does not match the set PIN, the printing does not start.

Print after reception is complete

This option is available in combination with **Print**. You can prevent degradation of print quality that occurs when receiving a print job is interrupted and printing is aborted in the middle.

Save in Job Box

Save print jobs on the permanent storage area of the printer's hard disk. Selecting this does not start printing.

Storage Destination

The storage area on the printer's hard disk is divided into a temporary storage area and a permanent storage area. The temporary storage area stores print jobs in the job queue or common job box. The permanent storage area stores jobs in personal job boxes.

Job queue

The job queue refers to print jobs that are being processed by the printer (saved, received, prepared for processing, printed, deleted, or held). Up to 100 jobs can be stored in the temporary storage area. However, the number of jobs available as queued jobs is up to 64.

When the maximum number of job queues are saved, the print job sent from the computer is in a state of waiting for processing.

However, if all saved job queue states are pending, the oldest job queue of the saved date and time will be deleted and the print job sent from the computer will be processed.

Common job box

Jobs for which you have specified **Print** in **Output Method** are saved in common job box and classified as saved jobs.

There is one common job box, numbered "00". A password cannot be set for common job box.

Up to 100 print jobs can be saved here. However, they will be deleted one after another starting with the oldest job in the following situations.

- If there are over 101 jobs queued and saved in common job box combined
- If no more temporary storage space is available when jobs for which you have selected **Print** in **Output Method** are received
- If there is not enough space in the temporary or permanent storage area when jobs for which you have selected **Save in Job Box** in **Output Method** are received.

Personal job boxes

In the following cases, the job is classified as saved job and saved in a personal job box on the permanent storage area.

- When a saved job stored in common job box is moved to a personal job box
- When you have selected **Save in Job Box** in **Output Method**

There are 29 personal job boxes, numbered "01" to "29". You can specify a name and password for each personal job box.

Up to 100 print jobs can be saved in all personal job boxes combined.

Saving Print Jobs in Personal Job Boxes

To save print jobs in personal job boxes, configure the printer driver.

Configuring Printer Driver (Windows)

1. Open printer properties dialog box.
 - ➔ [How to Open the Printer Driver Setup Window](#)
2. Select **Page Setup** tab.
3. Select **Output Method**.
4. Select **Save in Job Box** in **Output Method**.
5. In **Name of data to be saved**, specify how to name saved print jobs.
 - To use the file name, select **Use file name**.
 - Otherwise select **Enter name** and enter a name in **Name**.
6. Select a personal job box in **Job Box**.

▶▶▶ Note

- Select **Acquire Job Box Name** to display personal job box names in the **Job Box** list, as acquired from the printer.

7. Select **OK**.

Configuring Printer Driver (macOS)

1. Open printer properties dialog.
 - ➔ [How to Open the Printer Driver Setup Dialog](#)
2. Select **Additional Settings** in **Printer Options**.
3. Select **Save in Job Box** in **Output Method**.

Printing Saved Jobs

Print saved print jobs stored on the printer's hard disk as follows.

This operation is available using the operation panel or Remote UI.

➔ [Using Operation Panel](#)

➔ [Using Remote UI](#)

Using Operation Panel

1. Select  **Job management** on HOME screen.
2. Select **Saved job**.
3. In the list, select the target job box.

▶▶▶ Note

- If an administrator password is set, enter the password.

4. Select **Job list**.
5. In the list, select the target job.
6. Select **Print settings**.
7. Specify the number of copies.

1. To change the number of copies, select the number of copies display area (A).

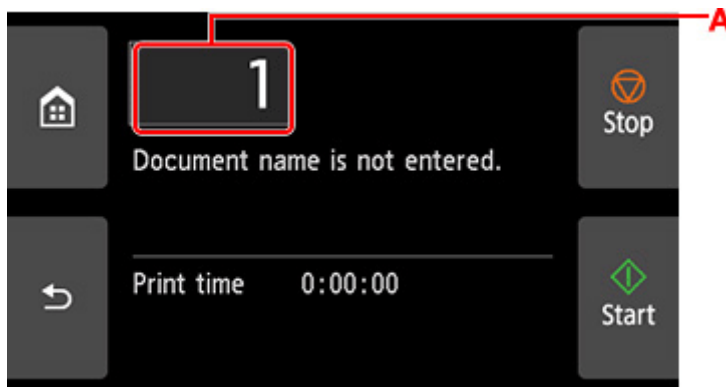

2. Specify the number of copies and select **OK**.



8. Select **Start**.

Using Remote UI

1. Start up Remote UI.
➔ [Start up Remote UI](#)
2. Select **Job management**.
3. Select **Saved job**.
4. In the list, select the target job box.

▶▶▶ Note

- If an administrator password is set, enter the password.

5. In the list, select the target job.
6. Select **Print**.
7. Enter the number of copies.
8. Select **Yes**.

Deleting Saved Jobs

Delete saved print jobs stored on the printer's hard disk as follows.

This operation is available using the operation panel or Remote UI.

➔ [Using Operation Panel](#)

➔ [Using Remote UI](#)

Using Operation Panel

1. Select  **Job management** on HOME screen.
2. Select **Saved job**.
3. In the list, select the target job box.

▶▶▶ Note

- If an administrator password is set, enter the password.

4. Select **Job list**.
5. In the list, select the target job.
6. Select **Delete**.
7. Confirm the message and select **Yes**.

Using Remote UI

1. Start up Remote UI.
➔ [Start up Remote UI](#)
2. Select **Job management**.
3. Select **Saved job**.
4. In the list, select the target job box.

▶▶▶ Note

- If an administrator password is set, enter the password.

5. In the list, select the target job.

6. Select **Edit**.

7. Select **Delete**.

8. Select **Yes**.

Moving Saved Jobs

Print jobs stored on the printer's hard disk (saved jobs) can be moved from the current job box to another job box as follows.

However, jobs saved in personal job boxes cannot be moved to common job box.

»» Important

- Jobs stored in common job box may be automatically deleted under some conditions. To prevent jobs from being deleted, move them from common job box to personal job boxes.

➔ [Using Printer Hard Disk](#)

1. Start up Remote UI.

➔ [Start up Remote UI](#)

2. Select **Job management**.

3. Select **Saved job**.

4. In the list, select the target job box.

»» Note

- If an administrator password is set, enter the password.

5. In the list, select the target job.

6. Select **Edit**.

7. Select **Move**.

8. Select **Destination job box**.

9. In the list, select the personal job box to move to and select **OK**.

»» Note

- If an administrator password is set, enter the password.

Saving Print Jobs Sent from Sources Other than Printer Driver

To save print jobs sent from software or systems other than the printer driver or applications provided with the printer, specify the output method and select the setting to perform printing after saving printing data using the operation panel.

▶▶▶ Note

- Contact the software or system developer for information about support for this printer function.

▶▶▶ Important

- The administrator password is required to change settings if it is enabled for changing settings using the operation panel.

➔ [Specifying Output Method](#)

➔ [Printing after Saving Printing Data](#)

Specifying Output Method

Perform settings for printing or saving print job.



1. Select **Printer settings** on HOME screen.

2. Select **Hard disk settings**.

Enter administrator password if it is enabled.

3. Select **Output method**.

4. Select the output method you want to set up.

Print

Save print jobs automatically at the same time they are printed.

Print (auto delete)

Save print jobs temporarily at the same time they are printed and delete them after printing.

Save to job box

Save print jobs on in the personal job box.

Printing after Saving Printing Data

To save print jobs on the hard disk before printing, select **ON** for **Save first and print**.

Printing will start when **Save first and print** is set to **ON**, even if you have selected **Save to job box** for **Output method**.



1. Select **Printer settings** on HOME screen.

2. Select Hard disk settings.

Enter administrator password if it is enabled.

3. Select Save first and print.

4. Select ON.

Printing without Saving Jobs in Common Job Box

Jobs sent from a computer for which you have selected **Print** in **Output Method** in the printer driver are saved in common job box.

➔ [Using Printer Hard Disk](#)

When **Common job box settings** is set to **Print (auto delete)** in the operation panel menu, print jobs for which you have selected **Print** in **Output Method** in the printer driver are deleted from common job box after printing.

Use this function when printing highly confidential documents.

▶▶▶ Important

- The administrator password is required to change settings if it is enabled for changing settings using the operation panel.



1. Select **Printer settings** on HOME screen.
2. Select **Hard disk settings**.
Enter administrator password if it is enabled.
3. Select **Common job box settings**.
4. Select **Print (auto delete)**.

Setting Passwords for Personal Job Boxes

For greater security, you can specify a password for personal job boxes. After setting the password, it is necessary to enter the password when performing the following operations.

- Change personal job box settings
- Display / print the list of jobs saved in personal job box, print / delete / move /rename jobs saved in personal job box

»» Note

- By default, no passwords are set for personal job boxes.
- A password cannot be set for common job box.
- Enter a seven-digit number as the password, in the range 0000001 to 9999999.
- Even if you have set passwords, they are not required to access personal job boxes in Administrator Mode in Remote UI.

1. Start up Remote UI.

➔ [Start up Remote UI](#)

2. Select **Job management**.

3. Select **Saved job**.

4. In the list, select the target job box.

5. Select **Edit**.

6. Select **Set/change password** check box and enter password. (This field is limited to seven digits in the range 0000001 to 9999999.)

7. Select **OK**.

Naming Personal Job Boxes

For easier identification, you can assign names to personal job boxes.

1. Start up Remote UI.

➔ [Start up Remote UI](#)

2. Select **Job management**.

3. Select **Saved job**.

4. In the list, select the target job box.

»» Note

- Enter the password if the personal job box has it.

5. Select **Edit**.

6. Enter name and select **OK**.

Printing List of Saved Jobs

The list of print jobs stored on the printer's hard disk (saved jobs) can be printed by job box as follows.

1. Select  **Job management** on HOME screen.
2. Select **Saved job**.
3. In the list, select the target job box.

»» Note

- Enter the password if the personal job box has it.

4. Select **Print the job list**.

For each job box, a list of saved jobs is printed.

Renaming Saved Jobs

Print jobs stored on the printer's hard disk (saved jobs) can be renamed as follows.

1. Start up Remote UI.

➔ [Start up Remote UI](#)

2. Select **Job management**.

3. Select **Saved job**.

4. In the list, select the target job box.

▶▶▶ Note

- Enter the password if the personal job box has it.

5. In the list, select the target job.

6. Select **Edit**.

7. Select **Change**.

8. Enter name and select **OK**.

Printer Hard Disk Operations

Printer hard disk operations are available from the following programs and interfaces.

- **Printer driver**
- **Remote UI**
- **Operation panel**

The hard disk operations available through each interface are as follows.

Operation		Printer driver	Remote UI	Operation panel
Saving print jobs	Save to job box	✓	-	-
	Print without saving jobs in common job box	-	-	✓
	Save print jobs sent from sources other than printer driver	-	-	✓
Operations with saved jobs	Print saved jobs	-	✓	✓
	Delete saved jobs	-	✓	✓
Job queue management	Display job queue	-	✓	✓
	Delete	-	✓	✓
	Priority printing	-	✓	✓
	Operations with pending jobs	-	✓	✓
	Operations with security print jobs	-	-	✓
	Delete Operations with security jobs	-	✓	✓
Job box management	Move saved jobs	-	✓	-
	Modify saved jobs	-	✓	-
	Modify job boxes	-	✓	-
	Print a list of saved jobs	-	-	✓
	Display a list of saved jobs	-	✓	✓
Other operations	Display free hard disk space	-	✓	✓
	Initialize hard disk	-	-	✓
	Display the time of printing	-	✓	✓
Display error messages		-	✓	✓

Checking Free Hard Disk Space

Check the space available on the printer's hard disk as follows.

This operation is available using the operation panel or Remote UI.

Using Operation Panel



1. Select **Printer information** on HOME screen.

2. Select **Hard disk information**.

The free hard disk space (job box free space) appears.

Using Remote UI

1. Start up Remote UI.

➡ [Start up Remote UI](#)

2. Select **Job management**.

3. Select **Hard disk information**.

The free hard disk space (job box free space) appears.

macOS Printer Driver

- **Overview of the Printer Driver**
- **Description of Print Dialog**
- **Updating the Printer Driver**

Overview of the Printer Driver

- **Canon IJ Printer Driver**
- **Checking Layout in Preview before Printing**
- **Registering a Changed Printing Profile**
- **How to Open the Printer Driver Setup Dialog**
- **Page Setup Dialog**
- **Print Dialog**
- **Updating Media Information in Printer Driver**
- **Correcting Media Information in Printer Driver (When Printer Used in Shared Environment)**
- **Confirm the Printer Paper Information**
- **Setting Accounting Information**
- **Set a PIN Code for Print Jobs**
- **Deleting the Undesired Print Job**
- **Display the Printing Status Screen**
- **Canon IJ Printer Utility2**
- **Opening the Canon IJ Printer Utility2**
- **Checking the Ink Status from Your Computer**
- **Instructions for Use (Printer Driver)**

Canon IJ Printer Driver

The Canon IJ printer driver (called printer driver below) is a software that is installed on your computer for printing data with this printer.

The printer driver converts the print data created by your application software into data that your printer can understand, and sends the converted data to the printer.

Because different models support different print data formats, you need a printer driver for the specific model you are using.

Using Help of the Printer Driver

You can display Help function from the [Print Dialog](#).

Select a setup item from **Print Options** in the Print dialog. Then click help  at the bottom left of the screen to display an explanation of the item.

Help for the printer driver is displayed when the following item in **Print Options** is selected:

- **Quality & Media**
- **Color Options**
- **Advanced Paper Settings**
- **Page Processing**
- **Additional Settings**

Checking Layout in Preview before Printing

You can display and check the print result before printing.

The procedure for displaying the print result before printing is as follows:

1. Select **Quality & Media** from **Printer Options** in the [Print Dialog](#)

2. Select Print Preview

Select the **Print Preview** check box.

3. Complete the setup

Click **Print**.

When executing printing, start up Canon imagePROGRAF Preview to display the print results.

▶▶ Note

- The printing results can be displayed even when selecting Canon imagePROGRAF Preview from **PDF**.

Registering a Changed Printing Profile

You can name and register the printing profile you made in the [Print Dialog](#). The registered printing profile can be called up from **Presets** to be used. You can also delete the unnecessary printing profile.

The procedure for registering a printing profile is as follows:

Registering a Printing Profile

1. In the Print dialog, set the necessary items
2. Select **Save Current Settings as Preset...** from the **Presets**
3. Save the settings

In the displayed dialog, enter a name in **Preset Name**, and if necessary, set **Preset Available For**. Then click **OK**.

Important

- There are also print settings that cannot be saved to preset.

Using Registered Printing Profile

1. On **Presets** in the Print dialog, select the name of printing profile you want to use
Printing profile in the Print dialog will be updated to the called profile.

Deleting Unnecessary Printing Profile

1. Select the printing profile to be deleted

In the print dialog, select **Edit Preset List...** in the **Presets** section. Then in the dialog that appears, select the name of the printing profile to be deleted.

2. Delete the printing profile

Click **-**, and click **OK**. The selected printing profiles will be deleted from **Presets**.

How to Open the Printer Driver Setup Dialog

You can display the printer driver setup dialog from the application software you are using.

Opening the Page Setup Dialog

Use this procedure to set the page (paper) settings before printing.

1. Select **Page Setup...** from the **File** menu of the application software

The [Page Setup Dialog](#) opens.

Opening the Print Dialog

Use this procedure to set the print settings before printing.

1. Select **Print...** from the **File** menu of the application software

The [Print Dialog](#) opens.

»» Important

- Depending on the macOS version or the application you are using, the print dialog screen display may differ.
Also, some features may be restricted.

Page Setup Dialog

In the Page Setup dialog, you configure the basic print settings such as the size of paper loaded in the printer or the scaling ratio.

To open the Page Setup dialog, you typically select **Page Setup...** from the **File** menu of your application software.

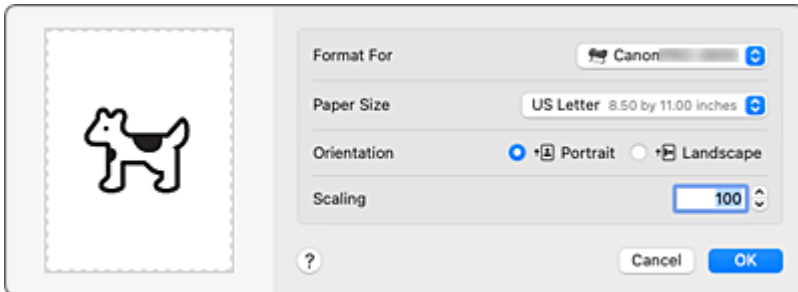

Format For

Select the model to be used for printing.

Paper Size

Select the size of the paper to be used for printing.

To set a non-standard size, select **Manage Custom Sizes....**

Orientation

Select the print orientation.

Scale

Set the scaling percentage.

You can expand or reduce the size of the document when printing.

Print Dialog

In the Print dialog, you can set paper type, paper source and print quality to start printing.

To open the Print dialog, you typically select **Print...** from the **File** menu of your application software.

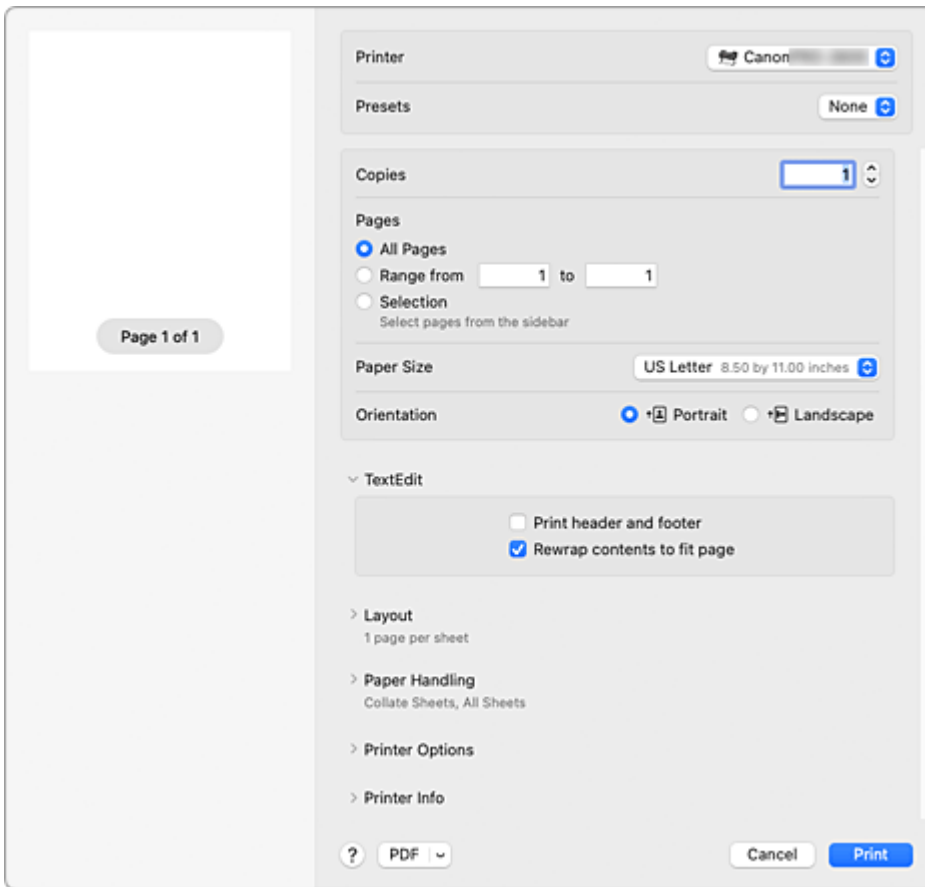

Printer

Select the model to be used for printing.

When you click **Add Printer...**, a dialog for specifying the printer opens.

Presets

You can save or delete the settings of the Print dialog.

Copies

You can set the number of copies to be printed.

»»» Note

- You can set collated printing by choosing **Paper Handling**.

Pages

You can set the range of pages to be printed.

Paper Size

Select the size of the paper to be used for printing.

To set a non-standard size, select **Manage Custom Sizes...**

Orientation

Select the print orientation.

Printer Options

You can switch between pages in the Print dialog by **Printer Options**. The first menu to appear differs depending on the application software that opened the Print dialog.

You can choose one of the following items from **Printer Options**.

Color Matching

You can select the color correction method.

Quality & Media

You can set basic print settings that match the printer.

Color Options

You can adjust the print colors as you desire.

Advanced Paper Settings

Specifies detailed print settings that match the media type loaded in the printer.

Page Processing

You can configure the detailed settings when printing to roll paper, and adjust the amount of the source document that sticks out from the page when printing all borderless.

Additional Settings

The output method can be set.

Printer Info

Supply Levels

A rough indication of the remaining ink level is displayed.

PDF

You can save a document in PDF (Portable Document Format) format.

By starting up Canon imagePROGRAF Free Layout, it is possible to allocate multiple source documents, and display the print results in imagePROGRAF Preview.

Updating Media Information in Printer Driver

This function gets the latest media information from the printer and updates the media information in the printer driver.

When the media information is updated, the media displayed for **Media Type** on the **Quality & Media** screen is updated to the latest information.

The procedure for updating media information is described below.



Update Media Information

1. From the [Canon IJ Printer Utility2](#) pop-up menu, select **Media Information**

2. Click **Update Media Information**

A dialog appears.

3. Check that the media information has updated

By following the dialog instructions, check that the printer is on, and then click **OK**.

After checking whether or not the printer media information needs to be updated, a message will be displayed.

If the printer media information is up to date, click **OK** and finish updating media information.

If the information needs to be updated, follow the below steps to do so:

4. Update media information

Check the message and click **Update**.

The printer driver media information will update.

When the authentication screen appears, enter the administrator's name and password, and then click **Install Helper**.

»» Important

- It may take some time to update the media information.
- Do not change media information on the printer while you are updating media information on the driver.

5. Finish updating media information

When a confirmation message appears, click **OK**.

The media information will be updated.

»» Important

- Restart the application or software you are printing from after updating media information.

»» Important

- Ensure that a user with administrator privileges carries out the media information update. Users other than administrators can check if a media information update is required, but cannot carry out the update itself.
- When you have added, deleted, or edited media using administrative tools (the Media Configuration Tool) but have not updated the media information, issues may arise such as the inability to print.

»» Note

- If the printer is being shared, **Correct Media Information** will display on the client machine.

Correcting Media Information in Printer Driver (When Printer Used in Shared Environment)

The printer driver media information will be corrected.

Carrying out a media information correction will correct the configuration of the media information in the printer driver.

The procedure for correcting media information is described below.



Correct Media Information

1. From the [Canon IJ Printer Utility2](#) pop-up menu, select **Media Information**

2. Click **Correct Media Information**

After checking whether or not the printer driver's media information is correct, a message will be displayed.

If the printer media information is set correctly, click **OK** and finish correcting media information.

If the information needs to be corrected, follow the below steps to do so:

3. Correct media information

When a confirmation message appears, click **OK**.

The printer driver media information will be corrected.

When the authentication screen appears, enter the administrator's name and password, and then click **Install Helper**.

4. Complete media information correction

When a confirmation message appears, click **OK**.

The paper information will be corrected.

▶▶ Important

- Restart the application or software you are printing from after correcting media information.

▶▶ Note

- **Media Information** will only be displayed on the client machine in use when the printer is being shared.

Confirm the Printer Paper Information

You can check the size and type of paper that was set to the printer.

1. From the [Remote UI](#), select **Printer status**
2. Check printer's paper information

The size and type of the media set on the printer main unit is displayed by feed position.

Setting Accounting Information

By Setting Accounting Information, you add IDs to print jobs, and use the printer and cost management tool to tabulate print history information for any ID.

The procedure for Setting Accounting Information is described below.

1. From the [Canon IJ Printer Utility2](#) pop-up menu, select **Accounting**

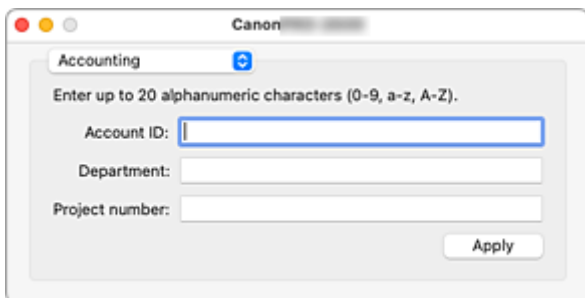

2. Set Account ID

Set an Account ID, as necessary.

Account ID/Department/Project number

Enter the Account ID, Department, or Project number to be set. Enter the ID by using up to 20 alphanumeric characters (0 to 9, a to z, A to Z).

3. Apply settings

Check that the printer is on, and then click **Apply**.

When the confirmation message appears, click **OK**.

The setting is now valid.

▶▶▶ Note

- If the printer is being shared, **Accounting** information cannot be set on client machines.

Set a PIN Code for Print Jobs

If you set a PIN code to your print jobs, the print jobs remain in standby status until the PIN code is entered on the printer operation panel.

As the material is printed immediately after entering the PIN code, issues such as retrieving the wrong documents and allowing others to peek at your documents can be prevented.

The procedure for setting a PIN code to your print jobs is explained here.

1. Select **Additional Settings** from **Printer Options** in the [Print Dialog](#)

2. Set the PIN code

Place a checkmark next to **Set PIN for printing**, and enter a one to seven-digit number in **PIN**.

3. Complete the setup

Click **Print**.

When you print, the print job is set to standby status on the printer unit.

If you enter the PIN code you set on the printer operation panel, the print job will be printed.

▶▶▶ Note

- See "[Printing Security Print Jobs](#)" for instructions on how to operate using the printer operation panel.
- Print jobs with a PIN code set are not saved on the printer hard disk.

Related Topics

- ➔ [Specifying Color Correction](#)
- ➔ [Adjusting Color Balance](#)
- ➔ [Adjusting Brightness](#)
- ➔ [Adjusting Contrast](#)

Deleting the Undesired Print Job

If the printer does not start printing, canceled or failed print job data may be remaining. Delete unnecessary print jobs from the print status check screen.

1. Open **System Settings, and select **Printers & Scanners****

2. Select your model, and then click **Printer Queue...**

The print status check screen appears.

3. Select the unnecessary print job and click 

The selected print jobs will be deleted.

Displaying the Printing Status Screen

Check the print progress according to the following procedure:

1. Launch the printing status screen

- If the print data has been sent to the printer

The printing status screen opens automatically. To display the printing status screen, click the printer icon displayed on the Dock.

- If the print data has not been sent to the printer





Open **System Settings**, and select **Printers & Scanners**.

To display the printing status screen, select the name of your printer model from the printer list, and then click **Printer Queue...**

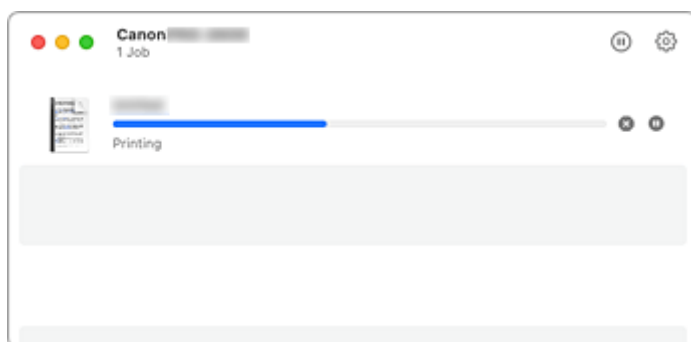
2. Checking the printing status

You can check the name of the file being printed or ready for being printed.



-  Deletes the specified print job.
-  Stops printing the specified document.
-  Resumes printing the specified document.
-  Stops printing all documents.
-  Displayed only when printing of all documents is being stopped, and resumes printing all documents.

▶▶▶ Note

- Depending on your model, the printer icon display may be different.

▶▶▶ Important

- If an error occurs, an error message will appear on the printing progress confirmation screen.
- The content of the error message may differ depending on the OS version.
- The printer part names in the error message may differ from what is listed in this manual.
- If the content of the error message is difficult to understand, check the error message displayed on the printer operation panel.

Canon IJ Printer Utility2

The Canon IJ Printer Utility2 allows you to update media information and configure accounting.

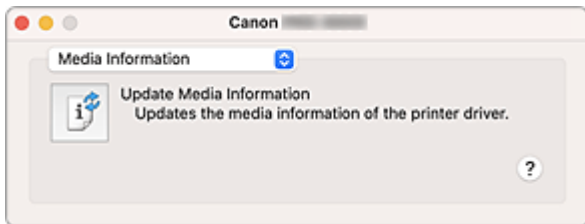

You can switch between pages in Canon IJ Printer Utility2 by the pop-up menu. You can choose one of the following items from the pop-up menu.

Media Information

Gets the latest media information from the printer and updates the media information in the printer driver.

Accounting

Allows you to set IDs for each job and each user, and manage the print history and print jobs.

▶▶▶ Note

- If the printer is being shared, **Accounting** information cannot be set on client machines.

▶▶▶ Note

- To operate the Canon IJ Printer Utility2, you must first turn on the printer.

Opening the Canon IJ Printer Utility2

To open the Canon IJ Printer Utility2, follow the steps below.

1. Open **System Settings**, and select **Printers & Scanners**

2. Start the Canon IJ Printer Utility2

Select your model from the printer list, and click **Options & Supplies...**

Click **Open Printer Utility** in **Utility** tab.

Canon IJ Printer Utility2 is launched.

Checking the Ink Status from Your Computer

You can check the detailed information such as the remaining ink level and the ink tank types of your model.

If you select **Printer status** from [Remote UI](#), an illustration showing the status of the ink tanks and maintenance cartridge appears.

Estimated ink levels

You can check the types and levels of ink.

When ink levels are running low or an error occurs because there is no ink, a notification icon will appear.

Ink model number

You can look up the correct ink tank for your printer.

Maintenance cartridge usage

You can check the estimated usage amount of the maintenance cartridge.

When capacity levels are low or the cartridge is at full capacity, a notification icon will appear.

»» Note

- To check the ink levels or the estimated usage of the maintenance cartridge, you can also select **Supply Levels** in **Printer Info**.

Instructions for Use (Printer Driver)

This printer driver is subject to the following restrictions. Keep the following points in mind when using the printer driver.

Restrictions on the Printer Driver

- When you set up the Page Setup dialog, be sure to begin by selecting the model you are using from the **Format For** list. If you select another printer, printing may not be performed properly.
- The following functions cannot be used in macOS, though they can be used in Windows computers.
 - Poster Printing
 - Stamp Printing
- Depending on the macOS version or the application you are using, the print dialog screen display may differ.
Also, some features may be restricted.
- If you connect this printer and AirPort with a USB cable and print, you must install the latest AirPort firmware.

Notes on Adding a Printer

- Install the Canon printer driver on a macOS, select your model from the Add Printer dialog, and then select Canon XXX (where "XXX" is your model name) from **Use** → **Select Software....**

Description of Print Dialog

- **Quality & Media**
- **Color Options**
- **Advanced Paper Settings**
- **Page Processing**
- **Additional Settings**

Quality & Media

This dialog allows you to create a basic print setup in accordance with the paper type. Unless special printing is required, normal printing can be performed just by setting the items in this dialog.

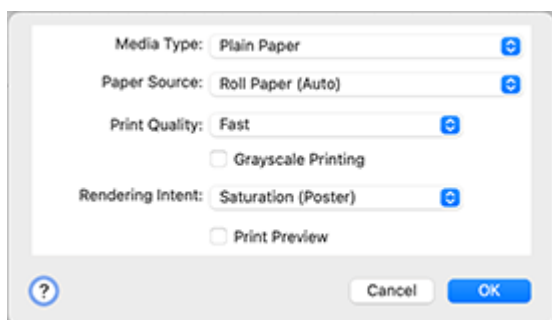

Media Type

Select the type of media to be used.

You must select the type of media actually loaded in the printer. This selection enables the printer to carry out printing properly for the material of the media used.

►►► Note

- After updating media information of the printer, start up the Canon IJ Printer Utility2 and update media information.

Paper Source

Select the source from which paper is supplied.

Roll Paper (Auto)

Depending on the paper settings on the printer driver and the paper information registered to the printer, the printer automatically determines which roll paper to use and then feeds that paper.

Roll 1

Paper is fed from Roll 1.

Roll 2

Paper is fed from Roll 2.

Cut Sheet

Feeds paper using the cut sheet.

Print Quality

Select the one that is closest to the original document type and the purpose.

When one of the radio buttons is selected, the appropriate quality will be set automatically.

High

Gives priority to print quality over printing speed.

Standard

Prints with average speed and quality.

Fast

Gives priority to printing speed over print quality.

Custom

Select this radio button to specify a quality.

Quality

When you select **Custom** in **Print Quality**, you can use the slider bar to adjust the print quality level.

Grayscale Printing

Print in grayscale.

Rendering Intent

Specify the method of matching to use when selecting **Canon Color Matching** in **Color Matching**.

Perceptual (Photo)

Reproduces colors of general photos naturally and features smooth gradation. In addition, selecting this setting allows you to adjust colors easily using an application software.

Saturation (Poster)

Reproduces vivid colors on data such as a poster.

No Color Correction

Performs printing without color matching.

Print Preview

You can start up the Canon imagePROGRAF Preview, and check what the printing results will be before executing the print.

Check this check box to display a preview before printing.

Related Topics

- ➔ [Switching the Paper Source to Match the Purpose](#)
- ➔ [Setting the Print Quality Level \(Custom\)](#)
- ➔ [Printing a Color Document in Monochrome](#)

Color Options

This dialog allows you to adjust the print color as you like. If the color of the printed image is not as expected, adjust the properties in the dialog and retry printing.

The adjustments made here do not affect the colors of the original print data unlike applications dedicated to image processing. Use this dialog just to make fine adjustments.

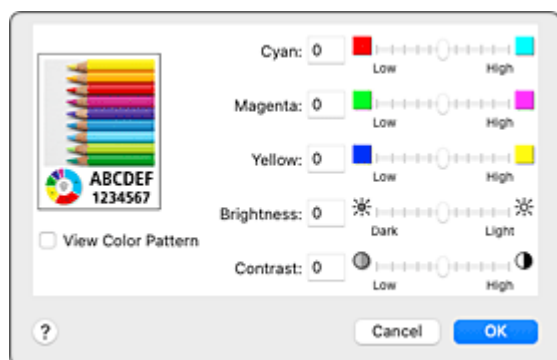

Preview

Shows the effect of color adjustment.

As you adjust each item, the effects are reflected in the color and brightness.

View Color Pattern

Displays a pattern for checking color changes produced by color adjustment.

When you want to display the sample image with a color pattern, check this check box.

►►► Note

- When the **Grayscale Printing** check box is checked in the **Quality & Media**, the sample graphic is displayed in monochrome.

Color balance (Cyan, Magenta, Yellow)

If necessary, adjust the strength of each color. To strengthen a color, drag the slider to the right. To weaken a color, drag the slider to the left.

You can also directly enter a value linked to the slider. Enter a value in the range from -50 to 50.

Adjusting the color balance will result in variations in the balance among the volumes of the individual color inks and hence in the hues of the document as a whole.

Use the printer driver only when adjusting the color balance slightly. To change the color balance significantly, use the application software.

Brightness

Adjusts the brightness of your print. You cannot change the levels of pure white and black. However, the brightness of the colors between white and black can be changed. Colors become brighter as you drag the slider toward the right and darker as you drag the slider toward the left. You can also directly enter brightness values that are linked to the slider bar. Enter a value in the range from -50 to 50.

Contrast

The Contrast function changes the differences between light and dark in images during printing.

To make the differences between the light and dark portions of images greater and more distinct, increase the contrast. On the other hand, to make the differences between the light and dark portions of images smaller and less distinct, reduce the contrast.

You can also directly enter a value linked to the slider. Enter a value in the range from -50 to 50.

Related Topics

- ➔ [Specifying Color Correction](#)
- ➔ [Adjusting Color Balance](#)
- ➔ [Adjusting Brightness](#)
- ➔ [Adjusting Contrast](#)

Advanced Paper Settings

Use this dialog box to set detailed print settings that match the media type loaded on the printer.

If the paper becomes stained during printing or if the quality of the print results is less than expected, using these settings may improve the print results.

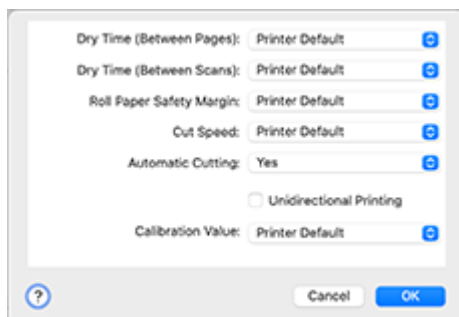

Dry Time (Between Pages)

Allows you to set the interval between the time each page is printed and the time it exits the printer. Since a certain waiting time is required for the ink to dry before the roll paper is cut, even when automatic cutting is set, you can cut the paper when the ink is dry.

The **Dry Time (Between Pages)** setting is effective only for roll paper.

Printer Default

Applies the settings configured in operation panel of the printer.

None

Documents are ejected immediately after printing is over.

30 seconds / 1 minute / 3 minutes / 5 minutes / 10 minutes / 30 minutes / 60 minutes

After printing is over, documents are ejected after the set time has elapsed.

Dry Time (Between Scans)

Allows you to set the interval between the printing of a scan on a page and the printing of the next scan. Prevents ink bleeding on a page or uneven coloring during borderless printing.

Printer Default

Applies the settings configured in operation panel of the printer.

None

Each scan is printed immediately after the previous one.

0.5 seconds / 1 second / 3 seconds / 5 seconds / 7 seconds / 9 seconds

After one scan has been printed, the next one will be printed after the set time has elapsed.

Increase the interval depending on the occurrence of bleeding and uneven coloring.

Roll Paper Safety Margin

Allows you to specify the length of the white margins on the edges of the paper in order to make even significantly curled paper adsorb to the platen.

Printer Default

Applies the settings configured in operation panel of the printer.

3mm

Prints in standard-size.

Choose this setting if there are no particular problems when printing.

20mm

Choose this setting in case of chafing against the print head, for example when using significantly curled paper.

Cut Speed

Allows you to select the speed of automatic cutting. Use it to adjust the automatic cutting function when clean cutting is not possible.

Printer Default

Applies the settings configured in operation panel of the printer.

Fast

Choose this if clean cut surfaces are not possible with the **Standard** setting.

Standard

Choose this if there are no particular problems with automatic cutting.

Slow

Choose it when using adhesive paper in order to prevent the glue from sticking to the cutter and to avoid a drop in cutting performance.

Automatic Cutting

You can set whether to have the paper cut automatically or to have cut lines printed on the paper. The following settings can be configured for automatic cutting.

Yes

Applies the settings configured in the operation panel of the printer unit.

None

After printing is over, the printer goes on to print the next set of data without cutting the paper into individual pages.

Print Cut Guideline

After printing is over, the printer prints cutting lines on each page and goes on to print the next set of data.

Unidirectional Printing

Suppresses uneven coloring and line shifts during printing.

To perform unidirectional printing, check this check box.

Calibration Value

Allows you to apply the results of calibration performed on the printer. To apply the calibration values, select **Use Value**.

Page Processing

You can configure advanced settings, such as for printing on roll paper and for adjusting how much of the document extends outside the paper when printing borderless.

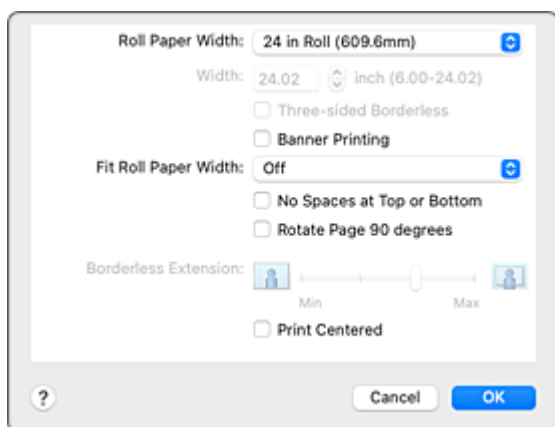

Roll Paper Width

Select the roll paper width.

Select the width that matches the width of the roll paper loaded in the printer.

Width

This enables you to select **Custom Size** in **Roll Paper Width**, allowing you to specify the roll width.

Three-sided Borderless

If you check this check box, and the width or the length of the output paper size is smaller than the roll width, a margin will be created on the right of the document, and the remaining three sides (top, bottom, and left) will be borderless when printing.

Banner Printing

Select this check box to print documents with several pages as one continuous document. When you do this, the spaces between the pages will be removed.

Fit Roll Paper Width

The printer automatically expands or reduces the document to match the roll paper width and then prints the document.

Off

The document is printed as-is without being expanded or reduced.

On (Bordered)

The printer automatically expands or reduces the document to match the roll paper width and then prints the document.

On (Borderless)

When borderless printing is performed, the printer automatically enlarges or reduces the document to match the roll paper width and then prints the document.

No Spaces at Top or Bottom

When printing on roll paper, you can save paper by reducing the upper and lower margins.

Rotate Page 90 degrees

When you print a portrait document onto roll paper, you can save paper by rotating the document 90 degrees and print the document horizontally relative to the paper.

Borderless Extension

Adjusts how much of the document extends outside the paper by using the **Borderless Extension** slider bar.

Drag to slider bar to the right to increase the extension amount, and to the left to decrease the extension amount.

Print Centered

Prints document in center of paper.

▶▶▶ Note

- Depending on the settings, some items cannot be set.

Related Topic

➔ [Prints without Edges Based on the Scenarios](#)

Additional Settings

Use this dialog to set the output method.

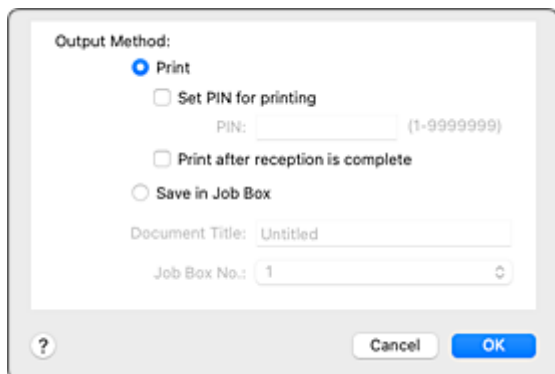

Output Method:

Print

Set PIN for printing

PIN: (1-9999999)

Print after reception is complete

Save in Job Box

Document Title:

Job Box No.:

Cancel OK

Output Method

Set the method for exporting the print job to the printer's hard disk drive.

Print

After the printing ends, the print job is not saved to the printer's hard disk drive.

Set PIN for printing

Set a PIN code for print jobs to prevent issues such as retrieving the wrong documents and allowing others to peek at your documents.

PIN

Enter a one to seven-digit number.

Print after reception is complete

This can be set when selecting **Print**.

If you check this, printing will start after the print job is received. This prevents a decrease in print quality due to the printing being suspended.

Save in Job Box

Save the print job to the hard disk of the printer. When selecting **Save in Job Box**, select the individual box to save to from the **Job Box No.** list.

Document Title

This can be set when selecting **Save in Job Box**.

Input the name of the document you wish to save.

Job Box No.

This can be set when selecting **Save in Job Box**.

Select the box number from the list.

Updating the Printer Driver

- **Obtaining the Latest Printer Driver**
- **Delete the Unnecessary Canon IJ Printer from the Printer List**
- **Before Installing the Printer Driver**
- **Installing the Printer Driver**

Obtaining the Latest Printer Driver

By updating the printer driver to the latest version of the printer driver, unresolved problems may be solved.

You can access our website and download the latest printer driver for your model.

»» Important

- You can download the printer driver for free, but any Internet access charges incurred are your responsibility.

Related Topics

- ➔ [Before Installing the Printer Driver](#)
- ➔ [Installing the Printer Driver](#)

Delete the Unnecessary Canon IJ Printer from the Printer List

A Canon IJ Printer that you no longer use can be deleted from the printer list.

Before deleting the Canon IJ Printer, disconnect the cable that connects the printer to the computer.

The procedure to delete the unnecessary Canon IJ Printer from the printer list is as follows:

You cannot delete the Canon IJ Printer unless you are logged on as a user with administrative rights.

1. Open **System Settings**, and select **Printers & Scanners**

2. Delete the Canon IJ Printer from the printer list

From the printer list, select the Canon IJ Printer to be deleted, and then click **Remove Printer...**

Click **Delete Printer** when the confirmation message appears.

Before Installing the Printer Driver

This section describes the items that you should check before installing the printer driver. You should also refer to this section if the printer driver cannot be installed.

Checking the Personal Computer Settings

- Terminate all running applications.
- Log on as a user who has the administrator account. The installer will prompt you to enter the name and password of the administrative user. When multiple users are using macOS, log on with the account of the administrator who registered first.

»» Important

- When you upgrade macOS, all printer drivers that were installed will be deleted. If you plan to continue using this printer, re-install the latest printer driver.

Related Topics

- ➔ [Obtaining the Latest Printer Driver](#)
- ➔ [Installing the Printer Driver](#)

Installing the Printer Driver

You can access our web site through the Internet and download the latest printer driver for your model.

The procedure for installing the downloaded printer driver is as follows:

1. Mount the disk

Double-click the disk image file you have downloaded.

The file is unpacked, and then the disk is mounted.

2. Start the installer

Double-click "PrinterDriver_XXX_YYY.pkg" (where "XXX" is your model name, and "YYY" is version) contained in the disk.

3. Start the installation

Install the printer driver according to the messages on the screen.

When the Software License Agreement is displayed, check the contents, and click **Continue**. If you do not agree to the terms of the Software License Agreement, you cannot install this software.

4. Selecting the install destination

If necessary, select where you want to install the printer driver, and then click **Continue**.

5. Executing the installation

Click **Install**.

When the authentication screen is displayed, enter the name and password of the administrator, and then click **Install Software**.

6. Complete the installation

When the completion message appears, click **Close**.

The printer driver is installed successfully.

▶▶ Important

- If the Installer does not operate properly, select **Quit Installer** from the **Installer** menu of the Finder to quit the Installer. Then start the Installer again.
- You can download the printer driver for free, but you are responsible for paying any connection fees to the Internet.

Related Topics

- ➔ [Obtaining the Latest Printer Driver](#)
- ➔ [Delete the Unnecessary Canon IJ Printer from the Printer List](#)
- ➔ [Before Installing the Printer Driver](#)

Handling Paper

► Handling rolls

- Loading Rolls on the Roll Holder
- Loading Rolls in the Printer
- Loading Roll Paper in the Roll Unit
- Removing the Roll from the Printer
- Removing Roll Paper from the Roll Unit
- Removing Rolls From the Roll Holder
- Feeding Roll Paper Manually
- Cutting Roll Paper
- Cutting Roll Paper after Printing
- Automatically Switch Rolls
- Remove Jammed Roll Paper

► Handling sheets

- Loading Sheets in the Printer
- Removing Sheets
- Printing From a Desired Starting Point
- Remove a Jammed Sheet

► Paper Settings

- Changing the Type of Paper
- Specifying the Paper Length
- Keeping Track of the Amount of Roll Paper Left
- Specifying the Cutting Method for Rolls
- Cutting the Leading Edge of Roll Paper Automatically
- Reducing Dust from Cutting Rolls
- Specifying the Ink Drying Time
- Specifying the Amount of Extension for Borderless Printing

► **Information about Paper**

- Paper Sizes
- Paper Information List
- Updating paper information
- Using Paper Other Than Genuine Paper and feed confirmed Paper
 - Printing on Paper Other Than Genuine Paper and feed confirmed Paper Using Existing Settings
 - Printing on Paper Other Than Genuine Paper and feed confirmed Paper by Adding a Media Type
- Managing Paper Information on Printer Using Media Configuration Tool

Handling rolls

- **Loading Rolls on the Roll Holder**
- **Loading Rolls in the Printer**
- **Loading Roll Paper in the Roll Unit**
- **Removing the Roll from the Printer**
- **Removing Roll Paper from the Roll Unit**
- **Removing Rolls From the Roll Holder**
- **Feeding Roll Paper Manually**
- **Cutting Roll Paper**
- **Cutting Roll Paper after Printing**
- **Automatically Switch Rolls**
- **Remove Jammed Roll Paper**

Loading Rolls on the Roll Holder

When printing on roll paper, attach the roll paper to the Roll Holder.

Roll paper comes in two types: 2-inch and 3-inch cores. If using 3-inch core roll paper, attach the 3-Inch Paper Core Attachment to the Roll Holder and holder stopper.

⚠ Caution

- Set the roll on its side on a table or other flat surface so that it does not roll or fall. Rolls are heavy, and dropping a roll may cause injury.

➤➤➤ Important

- When handling the roll, be careful not to soil the printing surface. This may affect the printing quality. We recommend wearing clean cloth gloves when handling rolls to protect the printing surface.
- Cut the edge of the roll paper if it is uneven, dirty, or has tape residue. Otherwise, it may cause feeding problems and affect the printing quality. Be careful not to cut through any barcodes printed on the roll.

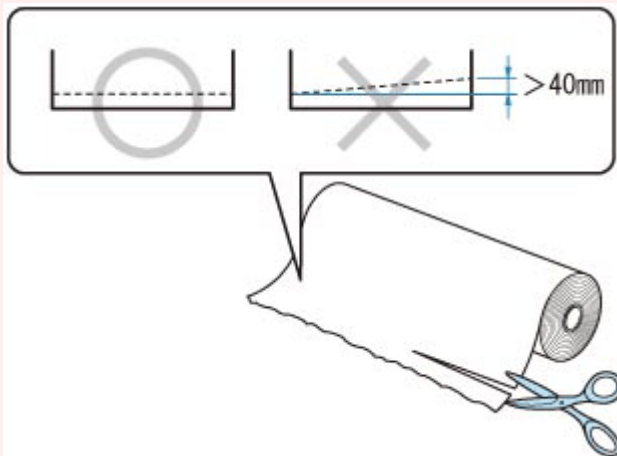

- Align the edges of the paper on both ends of the roll. This may cause feeding problems.

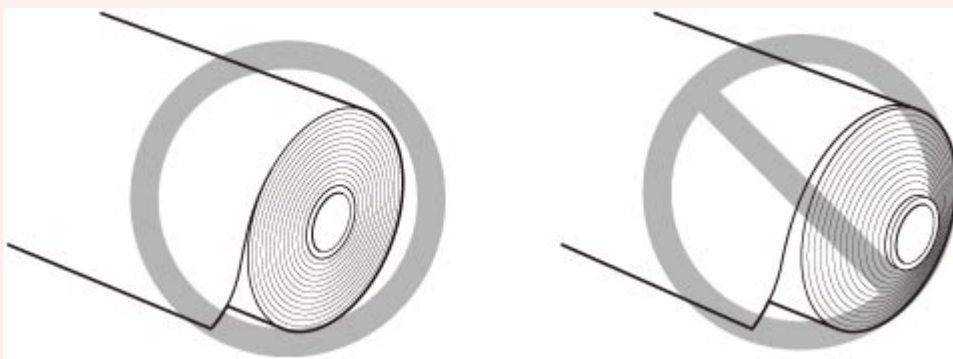

➤➤➤ Note

- For details on roll paper sizes and types that can be used, see "[Paper Sizes](#)" or "Paper Information List".

1. Rotate the holder stopper lever (A) towards  to release the lock, and while holding the end plate (B), remove holder stopper from the roll holder.

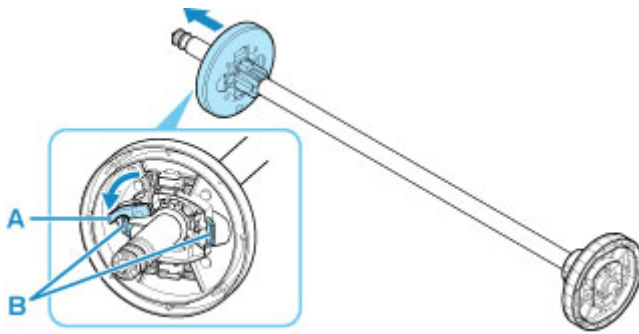

2. If using 3-inch core paper, align 3-Inch Paper Core Attachment tabs (A) with Roll Holder holes (B) and insert firmly.

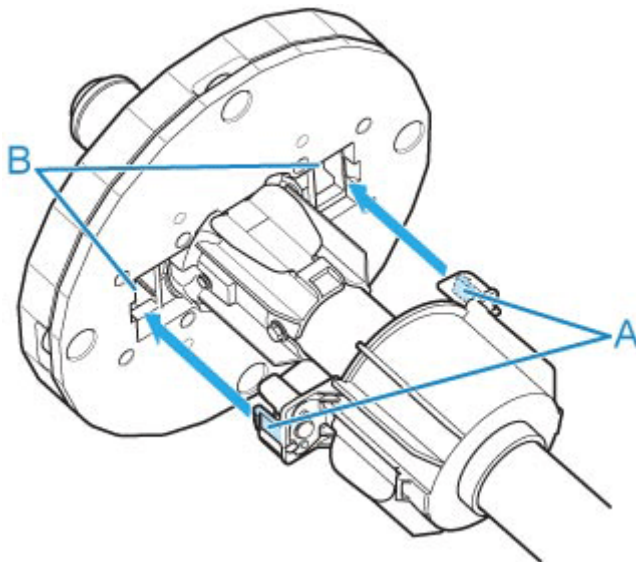

3. With leading edge of roll paper facing forward as shown, insert Roll Holder from right side of roll. Insert firmly until roll paper touches flange (A) of Roll Holder.

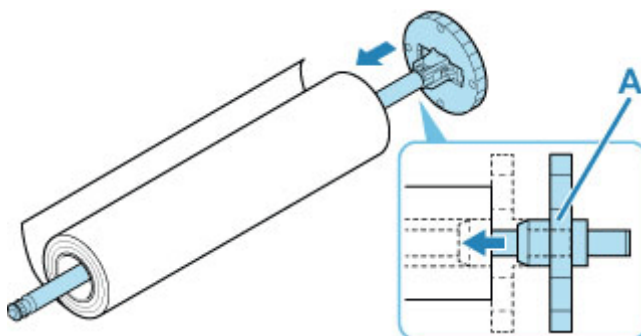



▶▶▶ Important

- When loading a roll, be careful to avoid hitting the printer hard with the roll. This may damage the Roll Holder.

- If you stand the roll holder vertically and set the roll paper by dropping, the roll holder may be damaged.

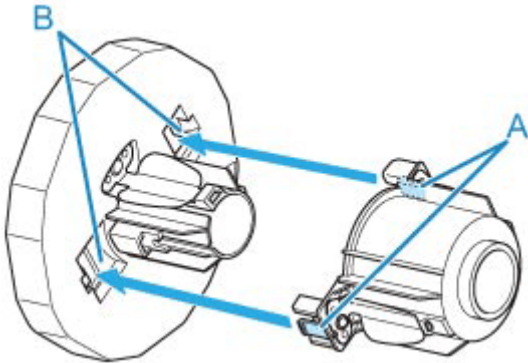
4. If using 3-inch core paper, align 3-Inch Paper Core Attachment tabs (A) with holder stopper holes (B) and insert firmly.



5. Insert holder stopper from left into roll holder as shown, and then while holding the end plate (B), push firmly until holder stopper flange (A) touches roll paper. Lock the holder stopper lever (C) by rotating it towards .

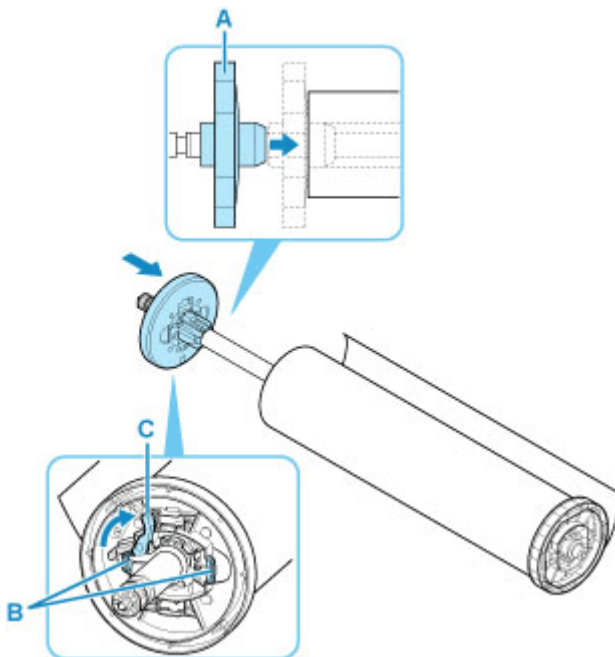

Loading Rolls in the Printer

Follow these steps to load rolls in the printer.

When selecting **Enable** in **Roll paper auto feed**, the roll paper is fed automatically by simply loading it.

Important

- Always load rolls when the printer is on. If the printer is off when you load a roll, the paper may not be advanced correctly when you turn the printer on.
- Before loading a roll, confirm whether the inside of the top cover or the output guide is soiled. If these areas are dirty, we recommend cleaning them in advance.
 - ➔ [Cleaning Inside the Top Cover](#)
- If **Paper retention settings** is set to **Release**, the roll paper is not fed automatically.
- For details on the paper that can feed roll paper automatically, see "Paper Information List."

Note

- When using the roll unit, you can also load roll paper on the roll unit separately from the printer that is described here.
 - ➔ [Loading Roll Paper in the Roll Unit](#)
- When roll paper cannot be fed automatically, see "[Roll Paper Is not Switched Automatically.](#)"

1. Select the paper setting display area on Home screen.

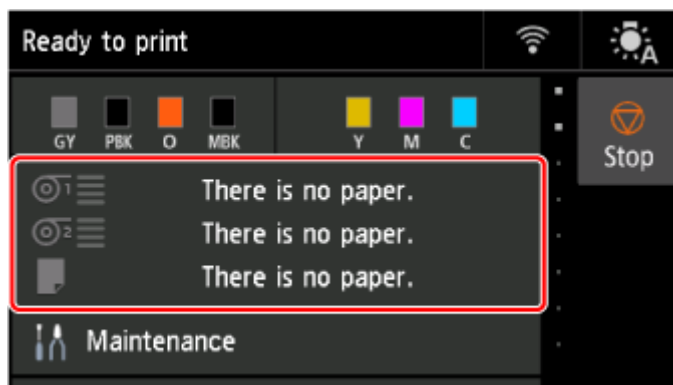

2. Select the **Roll paper 1** area.

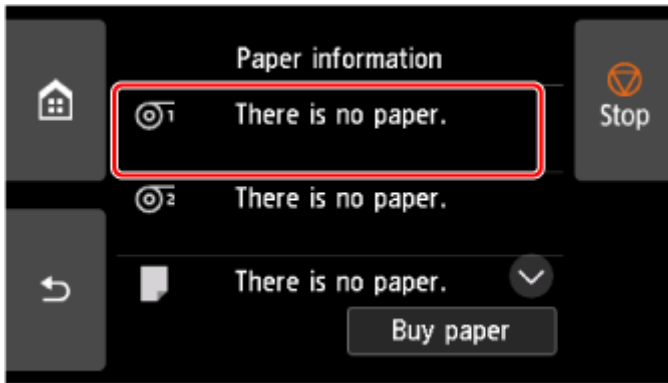

3. Select Load paper.

▶▶▶ Note

- If any paper has been advanced that will not be used, a message is shown requesting you to remove it. After following the instructions on the screen to remove the paper, go to the next step.

4. Open top cover and lift output guide.

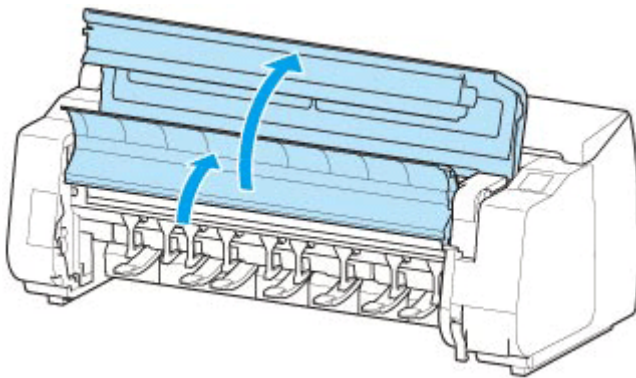

5. Hold flanges (A) so that holder stopper is on left, align roll holder shaft with roll holder slot left and right guide grooves (B), and load.

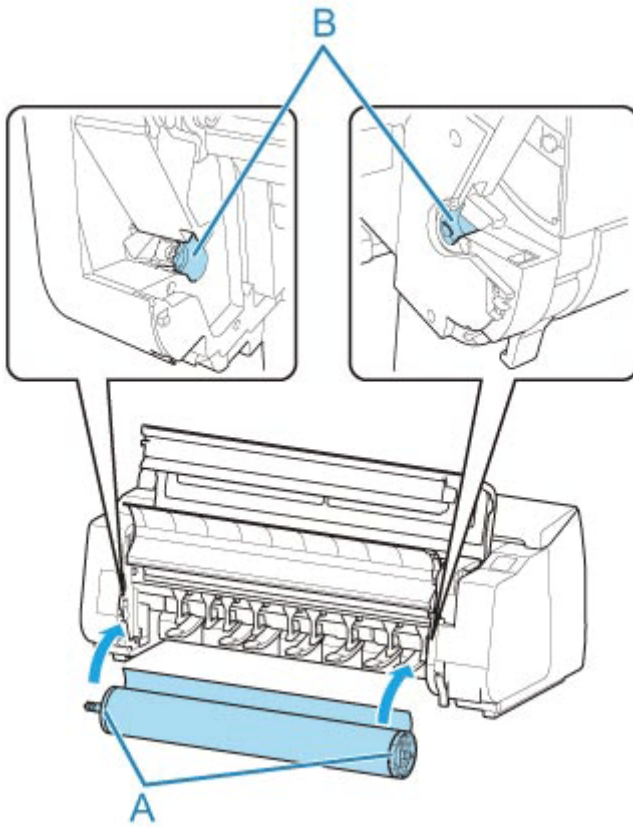

⚠ Caution

- Do not force the roll holder into the printer with the right and left ends reversed. This may damage the printer and roll holder.
- Do not release the flanges until the holder is loaded in the roll holder slot.
- Be careful not to pinch your fingers between the Roll Holder shaft and the guide grooves (B) when loading the roll paper.

▶▶ Important

- If the leading edge of the roll paper is secured with tape or a paper band so that it will not unravel, remove the tape or paper band before loading the roll paper into the roll holder slot.
If you load the paper into the roll holder slot with the leading edge secured, only part of the roll paper is fed to the paper feed slot, resulting in damage to the roll paper.
- If the leading edge of the roll paper is cut crooked or folded, it may not be fed correctly. Cut the leading edge of the roll paper with scissors or the like and straighten it.
- Load the roll paper so that it is not loaded in the opposite direction.
- Make sure there is no slack in the roll paper, and then load it.
- Depending on the surrounding environment, the leading edge of roll paper is stuck because of static electricity or humidity so that the roll paper may not be able to be fed correctly. In this case, set **Roll paper auto feed** to **Disable**, and then feed the roll paper.
- If the roll paper is decentered, it may not be able to be fed correctly. In this case, set **Roll paper auto feed** to **Disable**, and then feed the roll paper.

- When **Roll paper auto feed** is **Enable** and if you attach the roll holder without the roll paper loaded on the roll holder, **Preparing to feed the paper...** appears on the operation panel. In this case, press the **Stop** button on the operation panel to cancel feeding.

▶▶▶ Note

- For the procedure for attaching the roll paper to the Roll Holder, see "[Loading Rolls on the Roll Holder.](#)"

- **When selecting Enable in Roll paper auto feed.**

Go to step 6.

- **When selecting Disable in Roll paper auto feed.**

Pull out roll paper evenly, insert leading edge between roll paper and arrows (A) directly beneath it, and feed roll paper until you hear a sound.

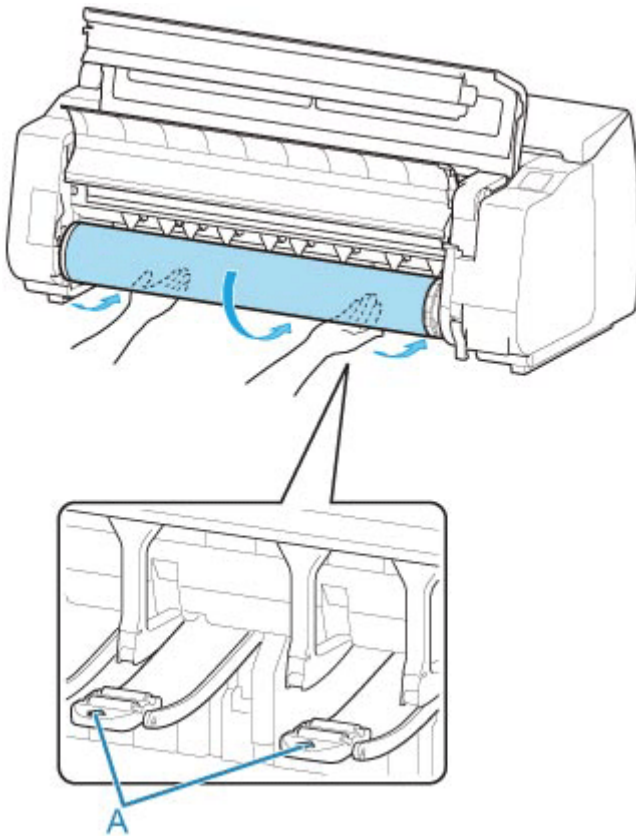

▶▶▶ Important

- If the roll paper has become unwound, remove the slack before loading the roll paper.
- When feeding the leading edge of the roll paper, make sure the entire width of the roll paper is separating and feeding from the roll. If the roll paper is fed with some of the roll paper still stuck to the roll, the roll paper will be damaged.
- Be careful not to soil the printing surface of roll paper as you insert it in the slot. This may affect the printing quality. We recommend wearing clean cloth gloves when handling rolls to protect the printing surface.

- If the paper is wrinkled or warped, straighten it out before loading it.
- Load the roll so that there is no gap between the right edge of the paper and the Roll Holder.

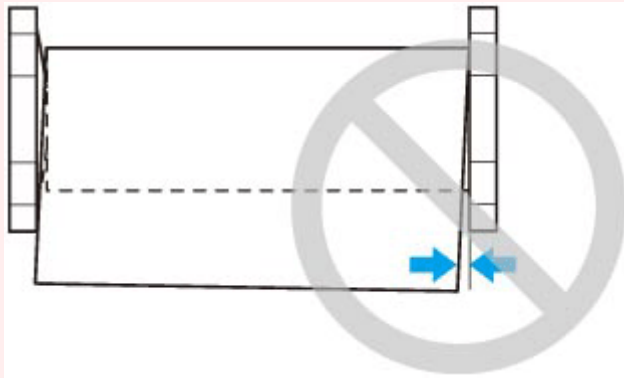

- Depending on the paper, the roll paper may be scratched when being fed and not feed well. In this case, you must feed the paper manually after setting **Paper retention settings** to **Release** on the touch screen. Lift the release lever, advance the roll paper until its leading edge appears on platen, lower the release lever, and then proceed to the next step. However, if **Paper retention settings** is set to **Release**, automatic switching of the upper and lower rolls is not possible.

3. Lower output guide.

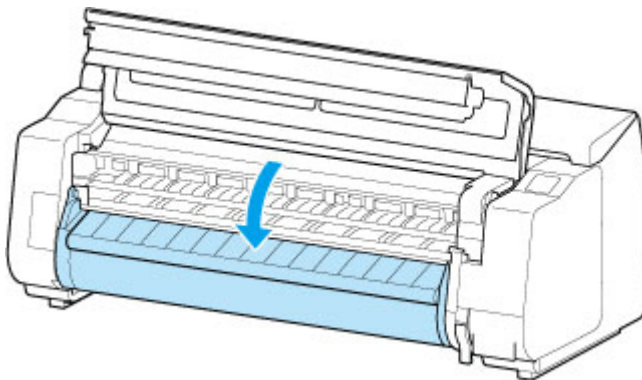

4. Close top cover.

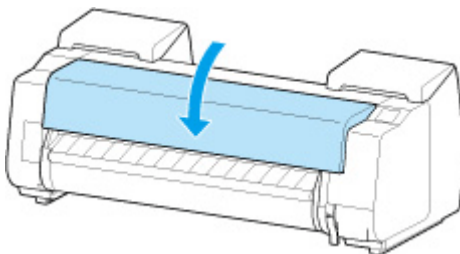

- **When selecting Enable in Roll paper auto feed.**
The roll paper is fed.
- **When selecting Disable in Roll paper auto feed.**
Select **Start feeding**, and then the roll paper is fed.

5. After paper feeding has started, do the following operations based on the **Manage remaining roll amount** setting and the barcode printed on the roll paper

➡ [Keeping Track of the Amount of Roll Paper Left](#)

- **When selecting Disable or Auto estimate in Manage remaining roll amount.**

- **When selecting Manual or Auto with confirmation in Media type selection method.**

- A menu for selecting the media type appears on the touch screen. Operate the touch screen and select the media type to be used.

- **When selecting Auto detect in Media type selection method.**

- You'll see candidate for the media type you've estimated to the touch screen. After 5 seconds, the paper type of the first item is selected. If you choose a different candidate, you can use the touch screen to select the type of paper you want.

- **When selecting Use current media type in Media type selection method.**

- A menu for selecting the media type appears on the touch screen. After 5 seconds, the media type will be selected with the fixed media kind.

- **When selecting Barcodes in Manage remaining roll amount and if the barcode is printed.**

- The type and amount of paper left is automatically detected based on the barcode printed on the roll. There is no need to specify the type and length of the paper.

- **When selecting Barcodes in Manage remaining roll amount and if the barcode is not printed.**

- **When selecting Manual in Media type selection method.**

- A menu for selection of the media type and length is shown on the touch screen. Operate the touch screen, select the media type to be used, and enter its length.

- **When selecting Auto with confirmation in Media type selection method.**

- A menu for selecting the estimated media type candidates and the paper length. Interact with the touch screen, select the media type you want to use, and enter the length.

- **When selecting Auto detect in Media type selection method.**

- A menu for selecting the estimated media type candidates and the paper length. After 5 seconds, the paper type of the first item is selected. If you choose a different candidate, you can use the touch screen to select the type of paper you want.

- **When selecting Use current media type in Media type selection method.**

- A menu for selecting the media type and the paper length appears on the touch screen. After 5 seconds, the media type will be selected with the fixed paper kind.

▶▶▶ Important

- If the leading edge of the roll paper is folded or dirty, cut the leading edge of the roll paper.

- ➡ [Cutting Roll Paper](#)

»» Note

- If you have selected **Auto with confirmation** or **Auto detect** in the **Media type selection method** and you are using the barcode to manage the remaining roll paper, the barcode is read first. If it fails to read the barcode, it will detect the media type from the estimated result and display the candidate.
- For details on media types that you can select, see "Paper Information List."
- The width of the roll paper is automatically detected by the printer when the paper is loaded.

When using roll paper with a user-defined size width, the detected width length and the set width length must exactly match, so even if the correct roll paper is loaded, detection may fail.

In this case, you can improve it by setting the roll paper width you want to use in **Add priority roll paper width**.

➡ [Add priority roll paper width](#)

Loading Roll Paper in the Roll Unit

Follow these steps to load roll paper in the roll unit.

When selecting **Enable** in **Roll paper auto feed**, the roll paper is fed automatically by simply loading it.

Important

- Always load rolls when the printer is on. If the printer is off when you load a roll, the paper may not be advanced correctly when you turn the printer on.
- Before loading a roll, confirm whether the inside of the top cover or the output guide is soiled. If these areas are dirty, we recommend cleaning them in advance.
 - ➔ [Cleaning Inside the Top Cover](#)
- If using the roll unit as the feed device, depending on the basket position, the ejected roll paper's cut end enters the roll unit and may cause a paper jam or affect the print quality when set to "Borderless Printing" or "Trim Edge First" when loading the paper. In this case, change the basket position, and then print.
 - ➔ [Example Basket Configurations](#)
- If **Paper retention settings** is set to **Release**, the roll paper is not fed automatically.
- For details on the paper that can feed roll paper automatically, see "Paper Information List."

Note

- When roll paper cannot be fed automatically, see "[Roll Paper Is not Switched Automatically.](#)"

1. Select the paper setting display area on Home screen.

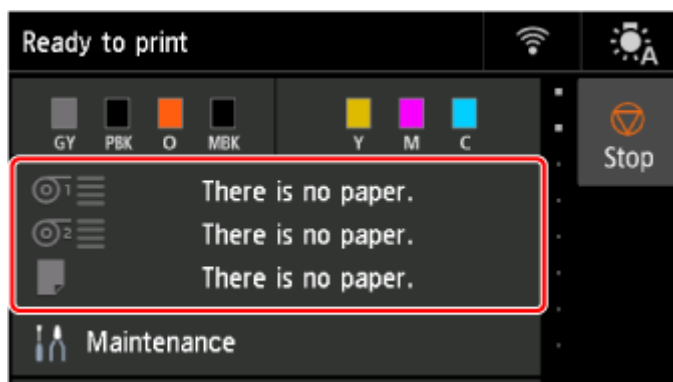

2. Select the **Roll paper 2** area.

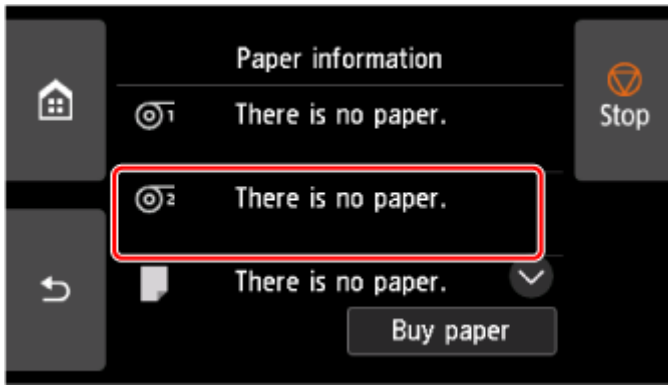

3. Select Load paper.

▶▶▶ Note

- If any paper has been advanced that will not be used, a message is shown requesting you to remove it. After following the instructions on the screen to remove the paper, go to the next step.

4. Change Roll Holder Lock switch on roll unit to release position.

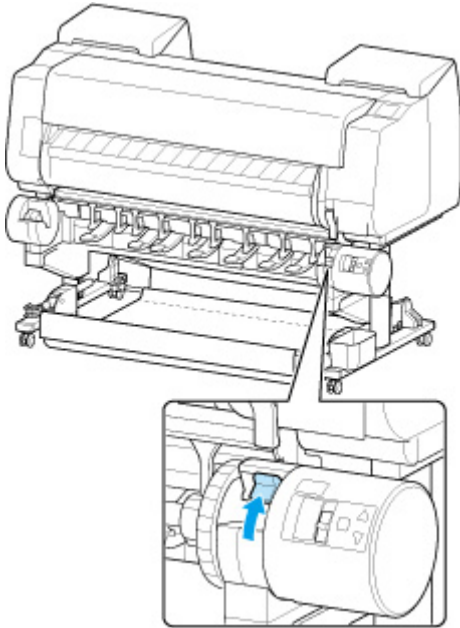

5. Hold flanges (A) so that holder stopper is on left, align roll holder shaft with roll holder slot left and right guide grooves (B), and load.

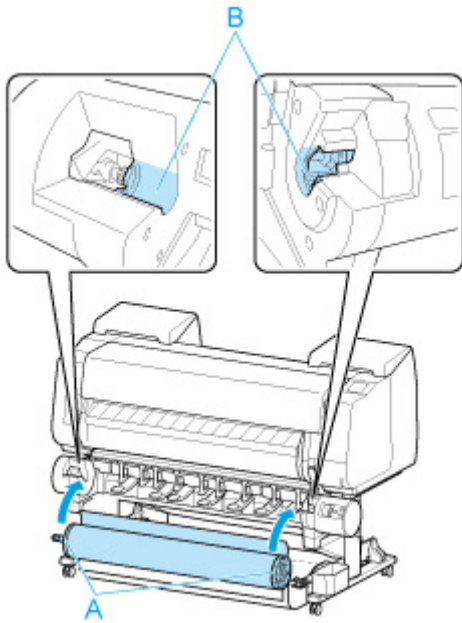

⚠ Caution

- Do not force the roll holder into the printer with the right and left ends reversed. This may damage the printer and roll holder.
- Do not release the flanges until the holder is loaded in the roll holder slot.
- Be careful not to pinch your fingers between the Roll Holder shaft and the guide grooves (B) when loading the roll paper.

»» Important

- If the leading edge of the roll paper is secured with tape or a paper band so that it will not unravel, remove the tape or paper band before loading the roll paper into the roll holder slot.
If you load the paper into the roll holder slot with the leading edge secured, only part of the roll paper is fed to the paper feed slot, resulting in damage to the roll paper.
- If the leading edge of the roll paper is cut crooked or folded, it may not be fed correctly. Cut the leading edge of the roll paper with scissors or the like and straighten it.
- Load the roll paper so that it is not loaded in the opposite direction.
- Make sure there is no slack in the roll paper, and then load it.
- Depending on the surrounding environment, the leading edge of roll paper is stuck because of static electricity or humidity so that the roll paper may not be able to be fed correctly. In this case, set **Roll paper auto feed** to **Disable**, and then feed the roll paper.
- If the roll paper is decentered, it may not be able to be fed correctly. In this case, set **Roll paper auto feed** to **Disable**, and then feed the roll paper.
- When **Roll paper auto feed** is **Enable** and if you attach the roll holder without the roll paper loaded on the roll holder, **Preparing to feed the paper...** appears on the operation panel. In this case, press the **Stop** button on the operation panel to cancel feeding.

▶▶▶ **Note**

- For the procedure for attaching the roll paper to the Roll Holder, see "[Loading Rolls on the Roll Holder.](#)"

6. Change **Roll Holder Lock** switch on roll unit to locked position.

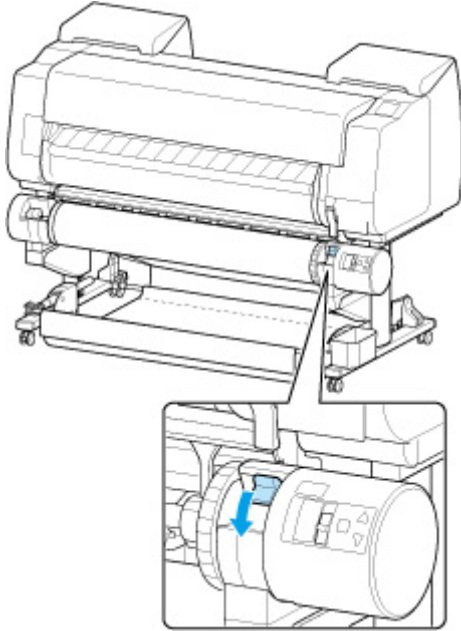

▶▶▶ **Important**

- If you do not change **Roll Holder Lock** switch to locked position, the roll paper cannot be fed automatically.

7. Change feed flap switch on top of roll unit to feed icon position on the left.

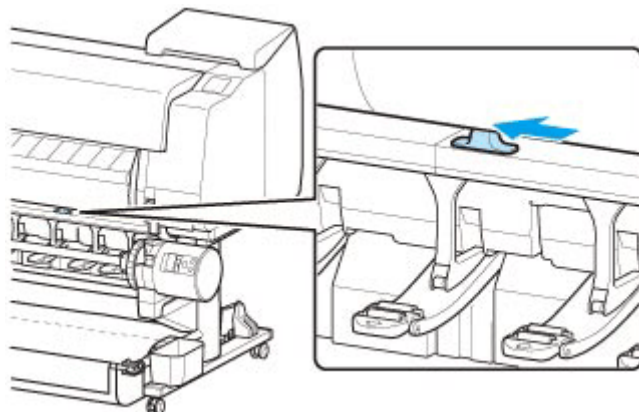

- **When selecting Enable in Roll paper auto feed.**

The roll paper is fed.

- **When selecting Disable in Roll paper auto feed.**

Pull out roll paper evenly, insert leading edge between roll paper and arrows (A) directly beneath it, and feed roll paper until you hear a sound.

Select **Start feeding**, and then the roll paper is fed.

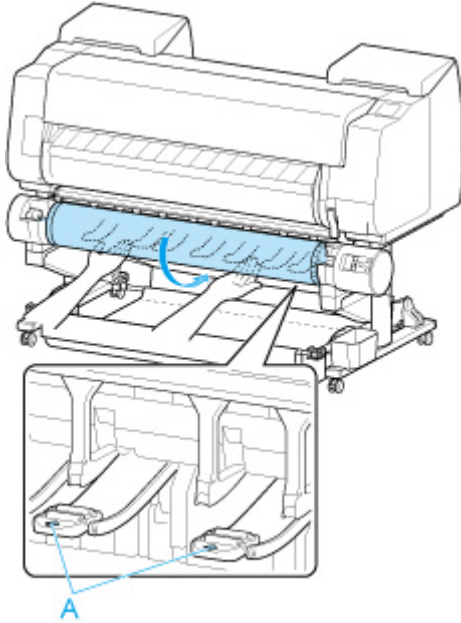

►► Important

- If the roll paper has become unwound, remove the slack before loading the roll paper.
- When feeding the leading edge of the roll paper, make sure the entire width of the roll paper is separating and feeding from the roll. If the roll paper is fed with some of the roll paper still stuck to the roll, the roll paper will be damaged.
- Be careful not to soil the printing surface of roll paper as you insert it in the slot. This may affect the printing quality. We recommend wearing clean cloth gloves when handling rolls to protect the printing surface.
- If the paper is wrinkled or warped, straighten it out before loading it.
- Load the roll so that there is no gap between the right edge of the paper and the Roll Holder.

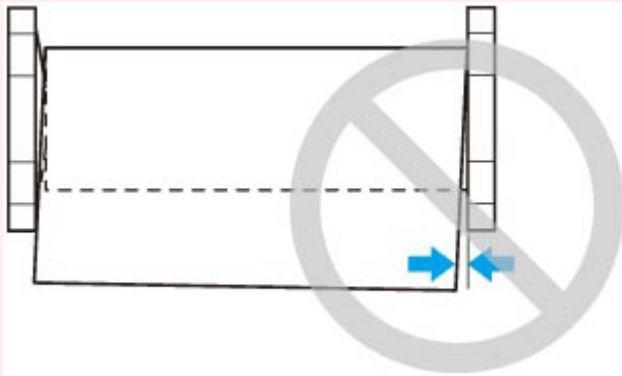

- Depending on the paper, the roll paper may be scratched when being fed and not feed well. In this case, you must feed the paper manually after setting **Paper retention settings** to **Release** on the touch screen. Lift the release lever, advance the roll paper until its leading edge appears on platen, lower the release lever, and then proceed to the next step. However, if **Paper retention settings** is set to **Release**, automatic switching of the upper and lower rolls is not possible.

8. After paper feeding has started, do the following operations based on the **Manage remaining roll amount** setting and the barcode printed on the roll paper

➡ [Keeping Track of the Amount of Roll Paper Left](#)

- **When selecting Disable or Auto estimate in Manage remaining roll amount.**

- **When selecting Manual or Auto with confirmation in Media type selection method.**

A menu for selecting the media type appears on the touch screen. Operate the touch screen and select the media type to be used.

- **When selecting Auto detect in Media type selection method.**

You'll see candidate for the media type you've estimated to the touch screen. After 5 seconds, the paper type of the first item is selected. If you choose a different candidate, you can use the touch screen to select the type of paper you want.

- **When selecting Use current media type in Media type selection method.**

A menu for selecting the media type appears on the touch screen. After 5 seconds, the media type will be selected with the fixed media kind.

- **When selecting Barcodes in Manage remaining roll amount and if the barcode is printed.**

The type and amount of paper left is automatically detected based on the barcode printed on the roll. There is no need to specify the type and length of the paper.

- **When selecting Barcodes in Manage remaining roll amount and if the barcode is not printed.**

- **When selecting Manual in Media type selection method.**

A menu for selection of the media type and length is shown on the touch screen. Operate the touch screen, select the media type to be used, and enter its length.

- **When selecting Auto with confirmation in Media type selection method.**

A menu for selecting the estimated media type candidates and the paper length. Interact with the touch screen, select the media type you want to use, and enter the length.

- **When selecting Auto detect in Media type selection method.**

A menu for selecting the estimated media type candidates and the paper length. After 5 seconds, the paper type of the first item is selected. If you choose a different candidate, you can use the touch screen to select the type of paper you want.

- **When selecting Use current media type in Media type selection method.**

A menu for selecting the media type and the paper length appears on the touch screen. After 5 seconds, the media type will be selected with the fixed paper kind.

Important

- If the leading edge of the roll paper is folded or stained, cut the leading edge of the roll paper.

➡ [Cutting Roll Paper](#)

»» Note

- If you have selected **Auto with confirmation** or **Auto detect** in the **Media type selection method** and you are using the barcode to manage the remaining roll paper, the barcode is read first. If it fails to read the barcode, it will detect the media type from the estimated result and display the candidate.
- For details on media types that you can select, see "Paper Information List."
- The width of the roll paper is automatically detected by the printer when the paper is loaded.

When using roll paper with a user-defined size width, the detected width length and the set width length must exactly match, so even if the correct roll paper is loaded, detection may fail.

In this case, you can improve it by setting the roll paper width you want to use in **Add priority roll paper width**.

➡ [Add priority roll paper width](#)

Removing the Roll from the Printer

Remove rolls from the printer as follows.

▶▶▶ Note

- If you need to cut a printed roll, cut the roll paper at the desired position.

➔ [Cutting Roll Paper](#)

1. Select the paper setting display area on Home screen.

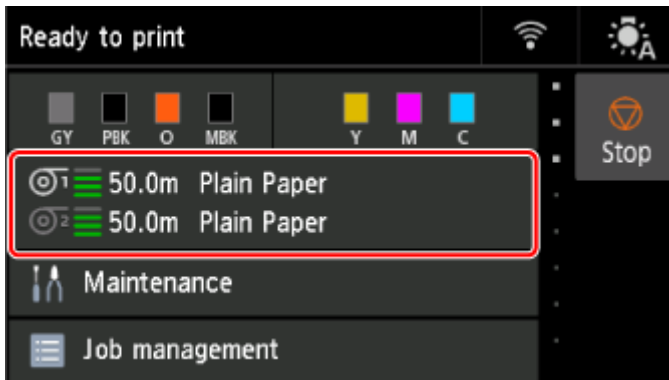

2. Select the **Roll paper 1** area.

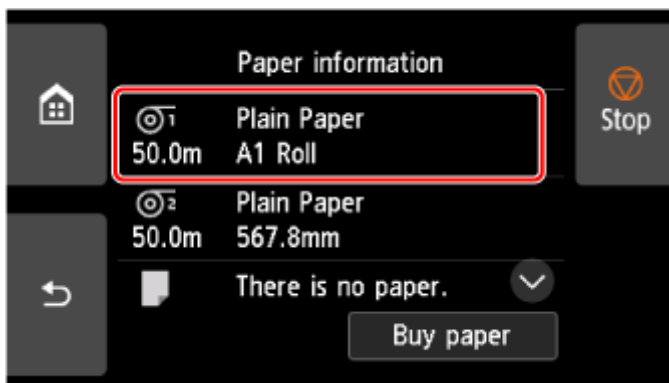

3. Select **Remove paper**.

4. Select **Yes**.

The roll is rewind.

▶▶▶ Important

- If **Manage remaining roll amount** is set to **Barcodes** in the operation panel menu, a barcode is printed on the leading edge of the roll paper.

Do not remove the roll before the barcode is printed. You will be unable to keep track of the amount of roll paper left.

➔ [Keeping Track of the Amount of Roll Paper Left](#)



5. Open top cover and lift output guide.

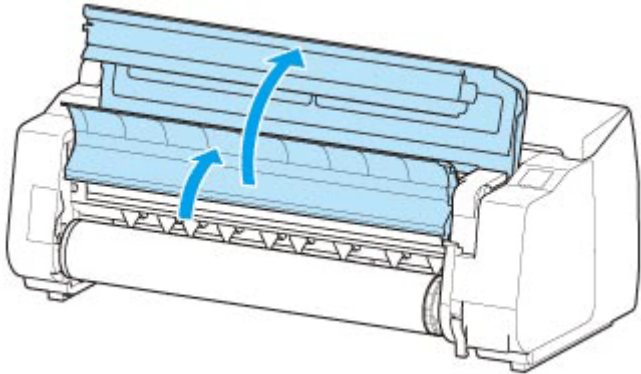

6. Using both hands, rotate the Roll Holder in the direction of the arrow to rewind the roll.

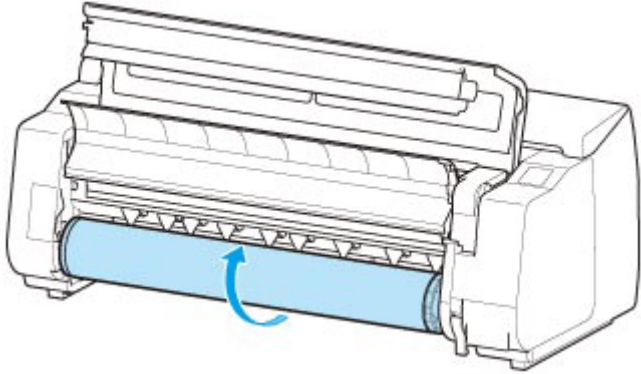

7. Hold Roll Holder by its flanges (A) and remove from roll holder slot.

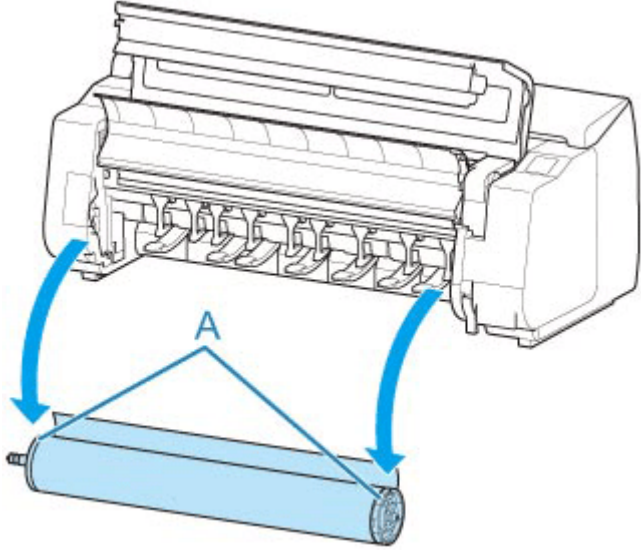

►►► **Note**

- For instructions on removing the Roll Holder from rolls, see "[Removing Rolls From the Roll Holder.](#)"

8. Lower output guide and close top cover.

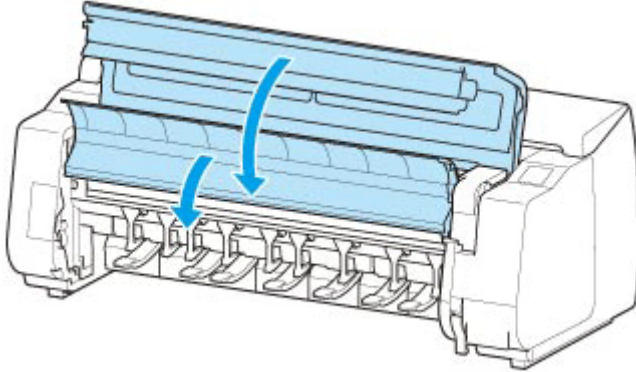

Removing Roll Paper from the Roll Unit

Follow these steps to remove roll paper from the roll unit.

▶▶▶ Note

- If you need to cut a printed roll, cut the roll paper at the desired position.

➔ [Cutting Roll Paper](#)

1. Select the paper setting display area on Home screen.

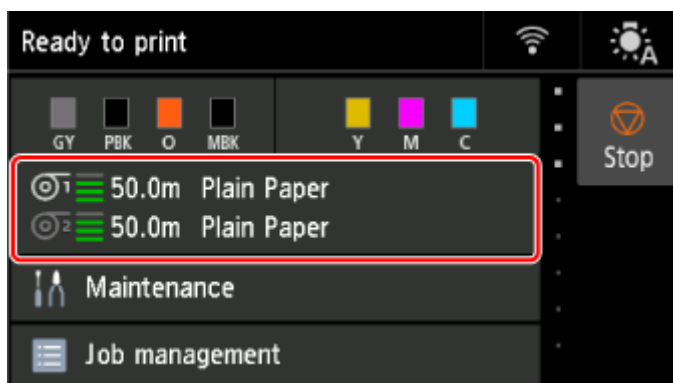

2. Select the **Roll paper 2** area.

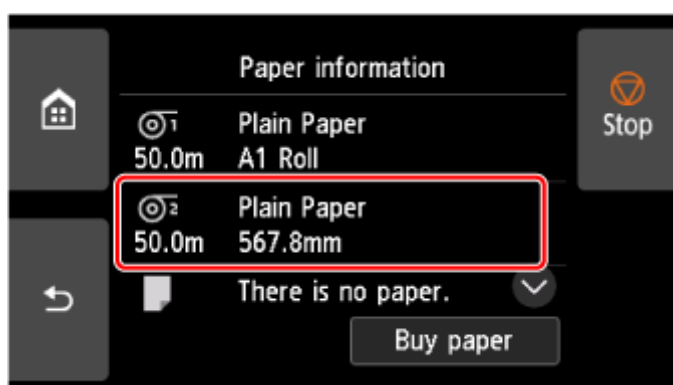

3. Select **Remove paper**.

4. Select **Yes**.

The roll is rewind.

▶▶▶ Important

- If **Manage remaining roll amount** is set to **Barcodes** in the operation panel menu, a barcode is printed on the leading edge of the roll paper.

Do not remove the roll before the barcode is printed. You will be unable to keep track of the amount of roll paper left.

➔ [Keeping Track of the Amount of Roll Paper Left](#)



5. Using both hands, rotate roll holder in direction of arrow to rewind roll paper.

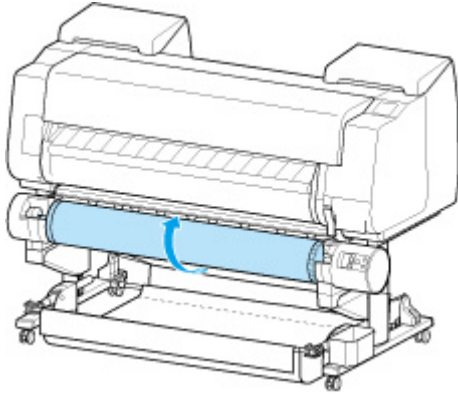

6. Change **Roll Holder Lock** switch on roll unit to release position.

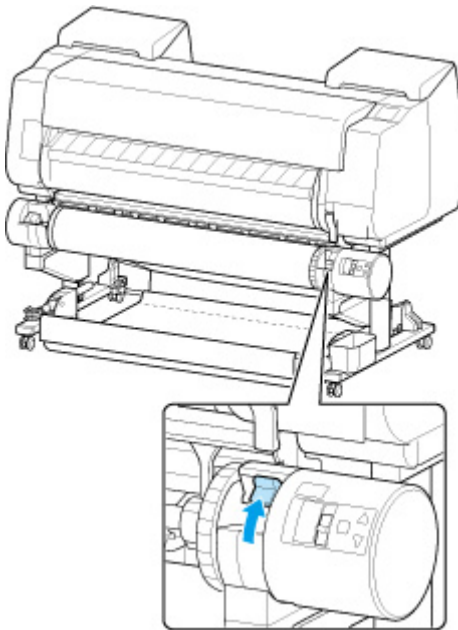

7. Hold roll holder by its flanges (A) and remove from roll holder slot.

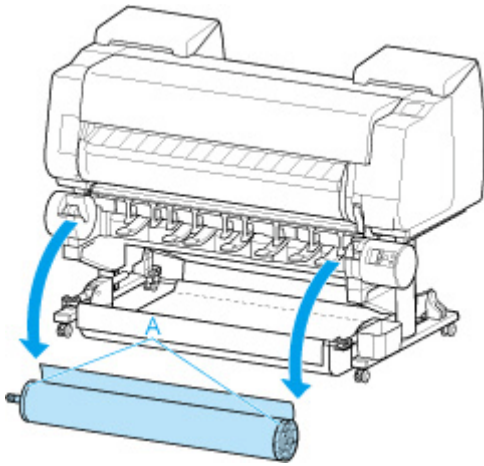

»» Note

- For instruction on removing the roll paper from the roll holder, see "[Removing Rolls From the Roll Holder.](#)"

Removing Rolls From the Roll Holder

1. Rotate the holder stopper lever (A) towards  to release the lock, and while holding the end plate (B), remove holder stopper from the roll holder.

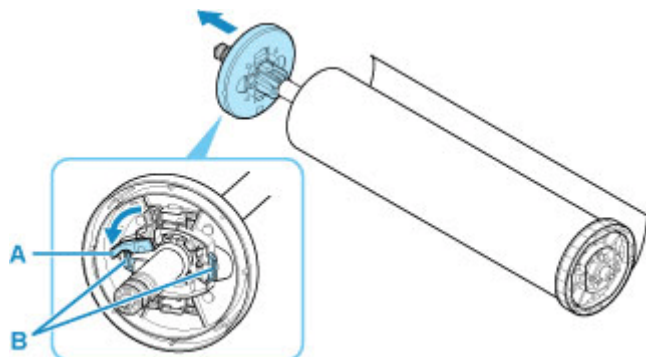

2. Remove roll holder from roll paper.

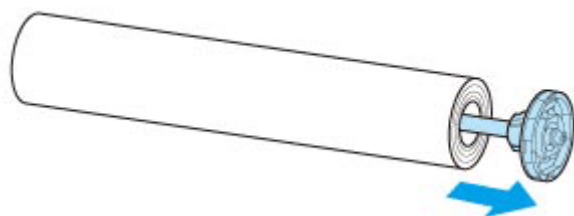

3. To remove 3-Inch Paper Core Attachment, press tabs (A) inward and remove attachment.

- roll holder Side

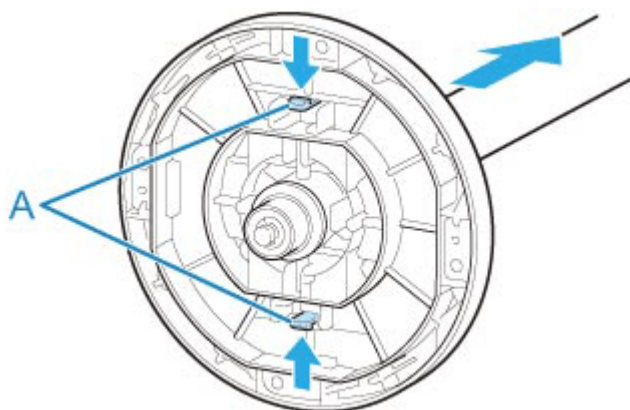

- holder stopper Side

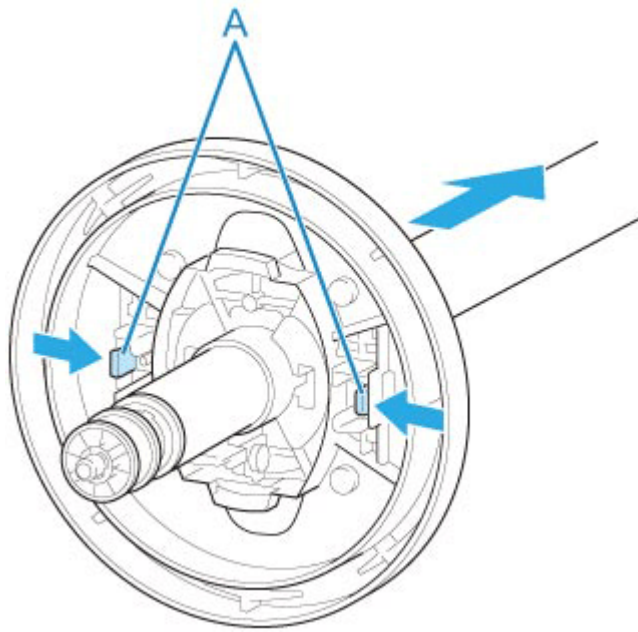

»» Important

- Store the roll in the original bag or box, away from high temperature, humidity, and direct sunlight. If paper is not stored properly, the printing surface may become scratched, which may affect the printing quality when you use it again.

Feeding Roll Paper Manually

After feeding the roll paper, you can move it forward and back.

1. Select the paper setting display area on Home screen.

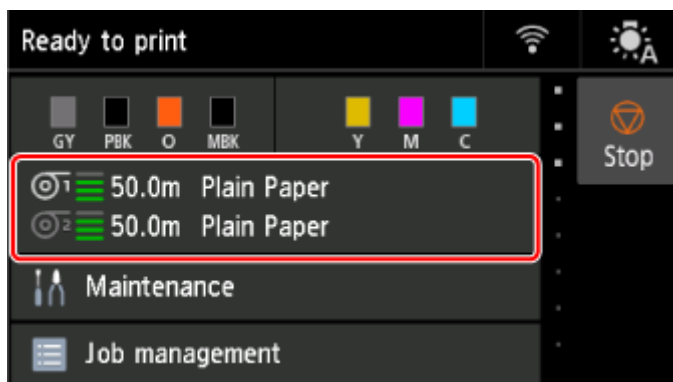

2. Select paper source.

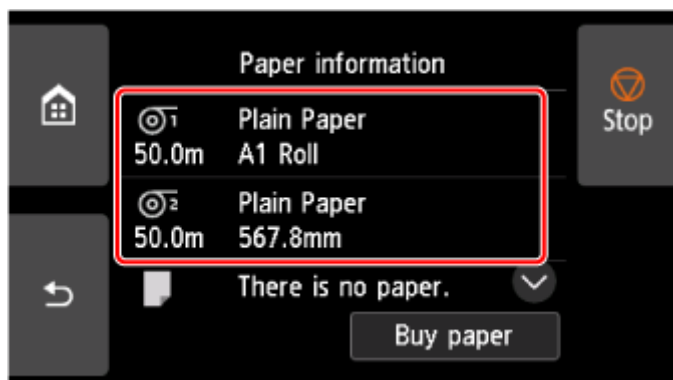

3. Select **Feed/cut**.

4. Tap or touch **Advance** and **Rewind** to move roll paper forward or back.

▶▶▶ Note

- Tapping **Advance** or **Rewind** moves the roll paper approximately 0.04 inch (1 mm).
Touching **Advance** or **Rewind** moves the roll paper until you release the key. If "**Cannot advance the paper any further.**" appears on the touch screen, release the key.

5. Select **OK** when you have determined position of roll paper.

Cutting Roll Paper

After feeding the roll paper, you can cut the roll paper.

1. Select the paper setting display area on Home screen.

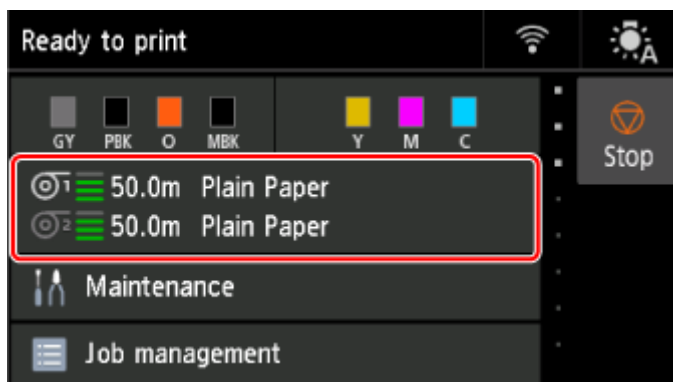

2. Select paper source.

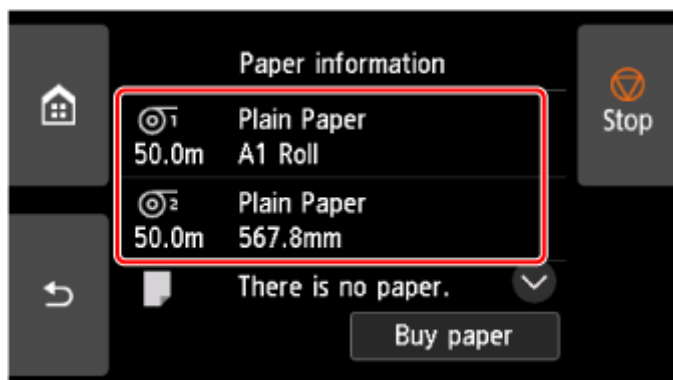

3. Select **Feed/cut**.

4. Tap or touch **Advance** and **Rewind** to move roll paper forward or back.

▶▶▶ Note

- Tapping **Advance** or **Rewind** moves the roll paper approximately 0.04 inch (1 mm).
Touching **Advance** or **Rewind** moves the roll paper until you release the key. If "**Cannot advance the paper any further.**" appears on the operation panel, release the key.

5. Select **Cut paper** when you have determined position of roll paper.

6. Check the contents of the message and select **Yes**.

After the roll paper is cut, it is rewound automatically.

Cutting Roll Paper after Printing

How rolls are cut after ejection varies depending on printer settings.

➔ [Specifying the Cutting Method for Rolls](#)

Eject (when the paper surface is being scratched / to wait for ink to dry)

»» Important

- When cutting wide printed documents after ejection, have two people support the documents. If the paper drops, printed documents may be damaged.
- Do not lift the paper when holding printed documents before cutting. If the paper rises, it may affect the printing quality or cause rough cut edges.

1. Print the job.

When printing is finished, the printer will stop without cutting.

2. While holding the printed document from the bottom edge to prevent it from dropping, select **Cut paper** to cut the roll paper.

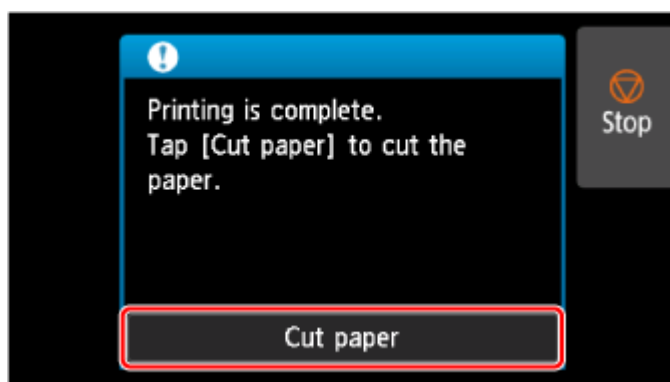

Manual (when using media that cannot be cut with the cutter blade)

1. Print the job.

The printer stops advancing the paper after printing.

2. Select **Advance paper**.

Roll paper is fed to the specified cut position and then automatically stopped.

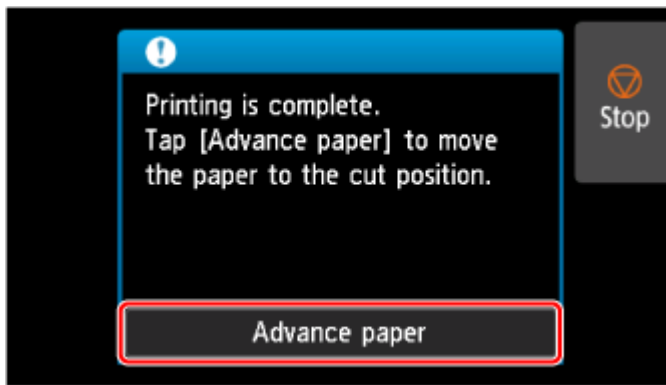

3. Cut the roll paper manually with scissors or the like.

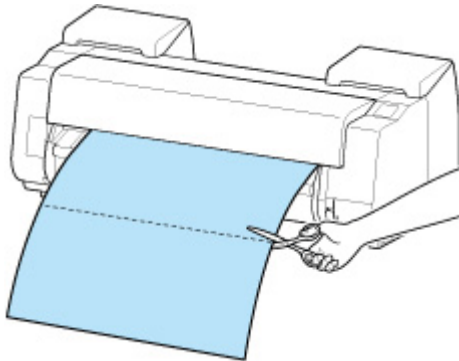

4. Select OK.

After the roll is rewound, it stops automatically.

Manual (for paper of which the leading edge rubs the print head)

1. Select the paper setting display area on Home screen.

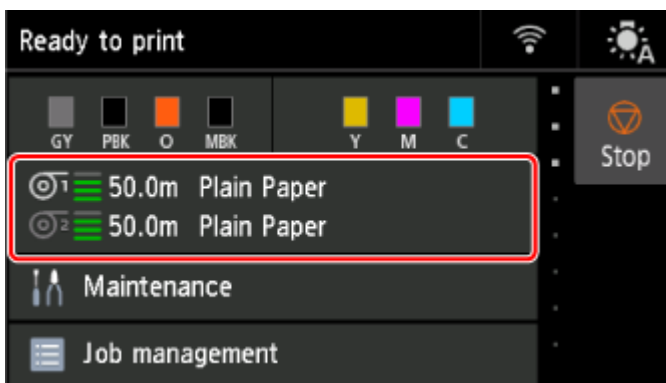

2. Select paper source.

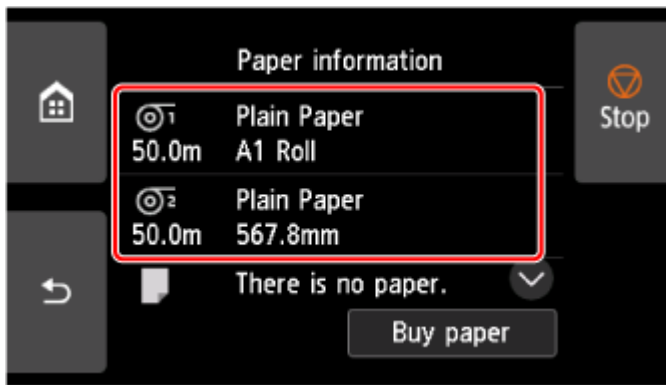

3. Select **Feed/cut**.

4. Tap or touch **Advance** or **Rewind** and align paper's leading edge with position (A).

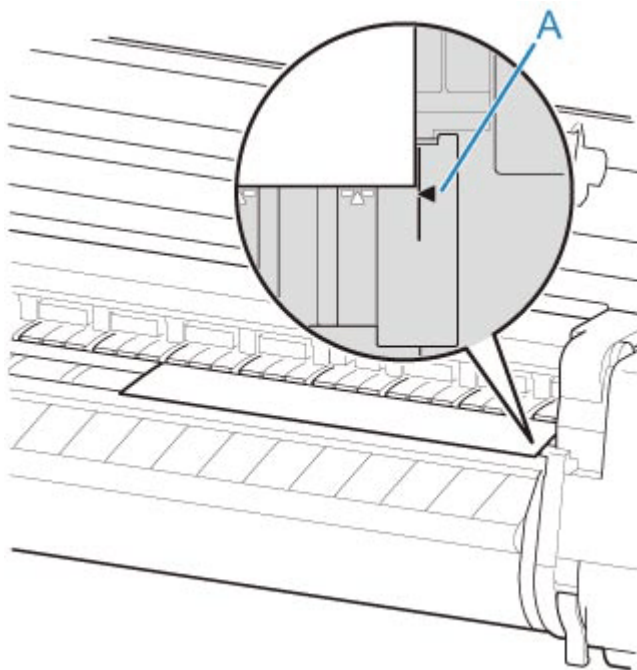

5. Print the job.

The printer stops advancing the paper after printing.

6. Select **Advance paper**.

Roll paper is fed to the specified cut position and then automatically stopped.

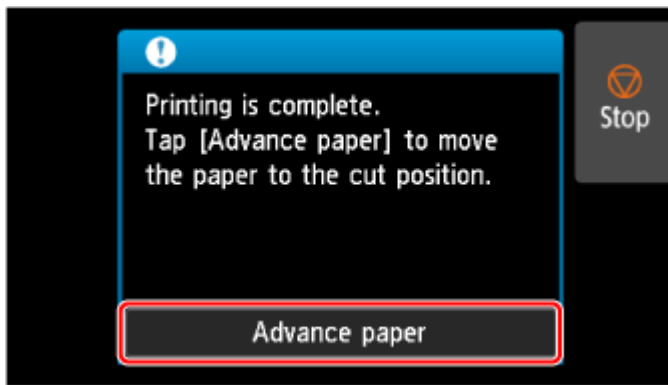

7. Cut the roll paper manually with scissors or the like.

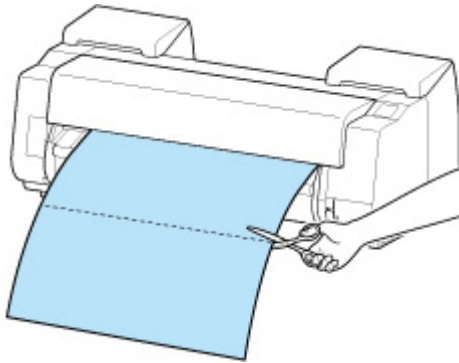

8. Select **OK**.

After the roll is rewound, it stops automatically.

Automatically Switch Rolls

By using the roll unit as a roll paper feed device, you can load an upper roll (Roll 1 on printer) and a lower roll (Roll 2 on the roll unit), and print on while automatically changing between Roll 1 and Roll 2 depending on the print job.

For details on how to switch between Roll 1 and Roll 2, see "How to Switch Paper Rolls" (Windows) or "[How to Switch Paper Rolls](#)" (macOS).

Important

- If **Paper retention settings** is set to **Release**, automatic switching of roll paper cannot be used.

Handling sheets

- **Loading Sheets in the Printer**
- **Removing Sheets**
- **Printing From a Desired Starting Point**
- **Remove a Jammed Sheet**

Loading Sheets in the Printer

Follow these steps to load sheets in the printer.

Important

- Paper that is wrinkled or warped may jam. If necessary, straighten the paper and reload it.
- Load the paper straight. Loading paper askew will cause an error.
➔ [1317](#)
- If you are not using the stand, make sure there is no object under the printer. If there is any object under the printer, it may cause damage of the paper or jamming.

Note

- Before loading cut sheets, check whether or not the inside of the top cover or the output guide is soiled. If these areas are dirty, we recommend cleaning them in advance.
➔ [Cleaning Inside the Top Cover](#)
- Store unused paper in the original package, away from high temperature, humidity, and direct sunlight.

1. Select the paper setting display area on Home screen.

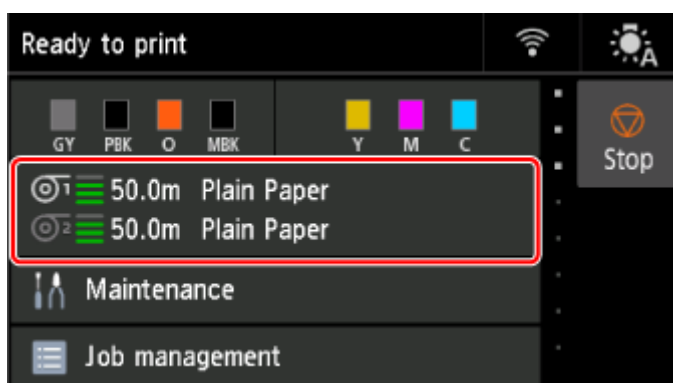

Note

- If a print job has been received in advance, follow the instructions on the screen and select **Load paper**.

2. Select the **Manual** area.

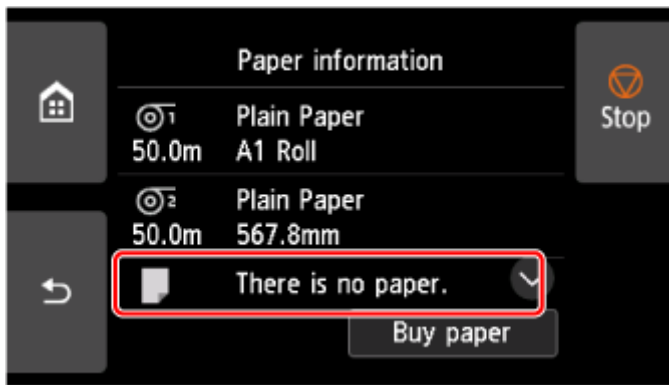

3. Select **Load paper**.

4. Open top cover and lift release lever.

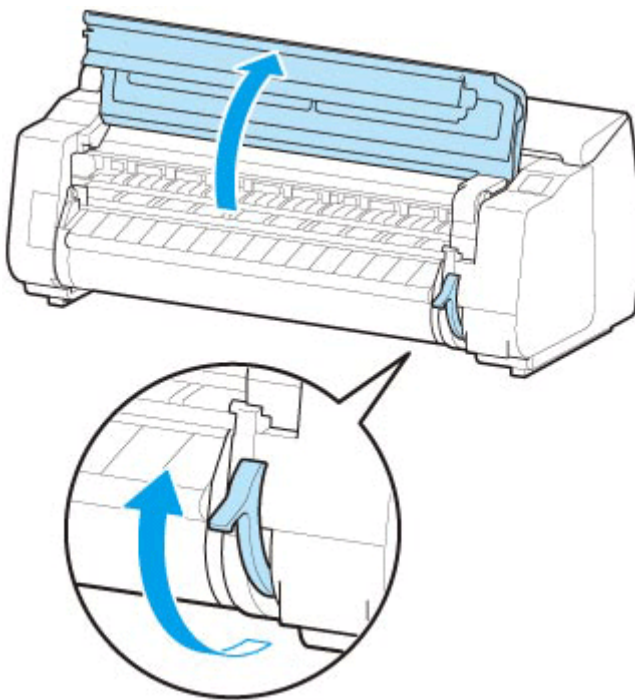

»»» Important

- Do not touch Linear Scale (A), carriage shaft (B), or Ink Tube Stabilizer (C). Touching these parts may damage them.

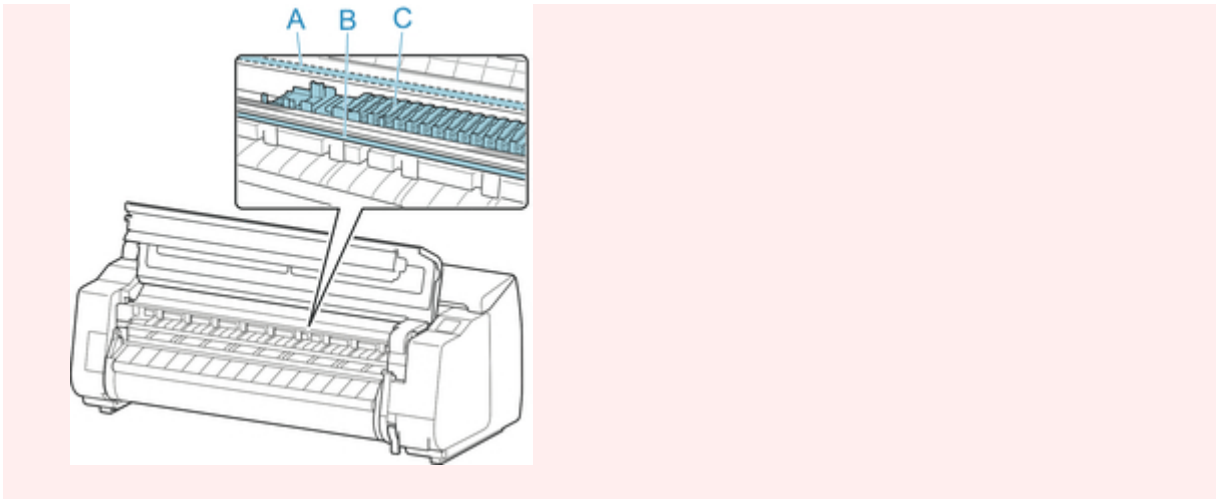

- 5. Insert the cut paper in portrait orientation, with the print side up, between the platen (D) and the paper retainer (E).

When the cut paper is inserted, it is automatically adsorbed onto platen surface.

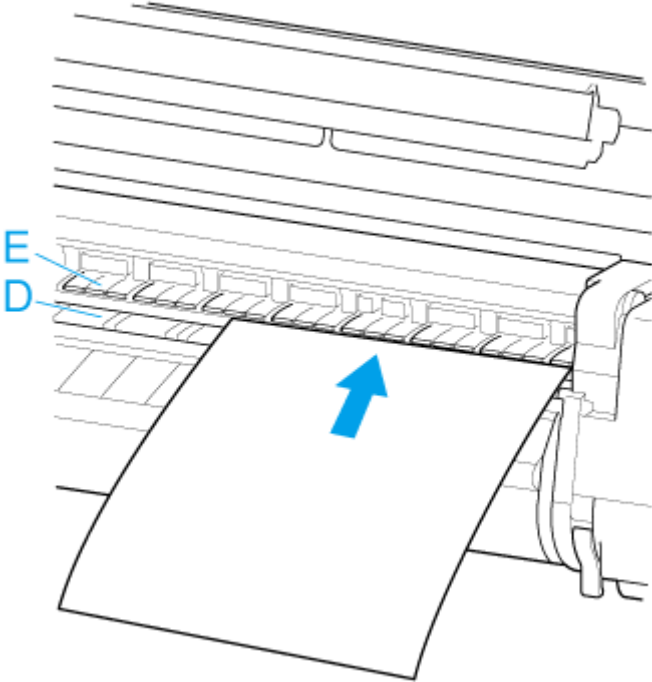

- 6. Align the paper with the paper alignment line (F) on the right side.

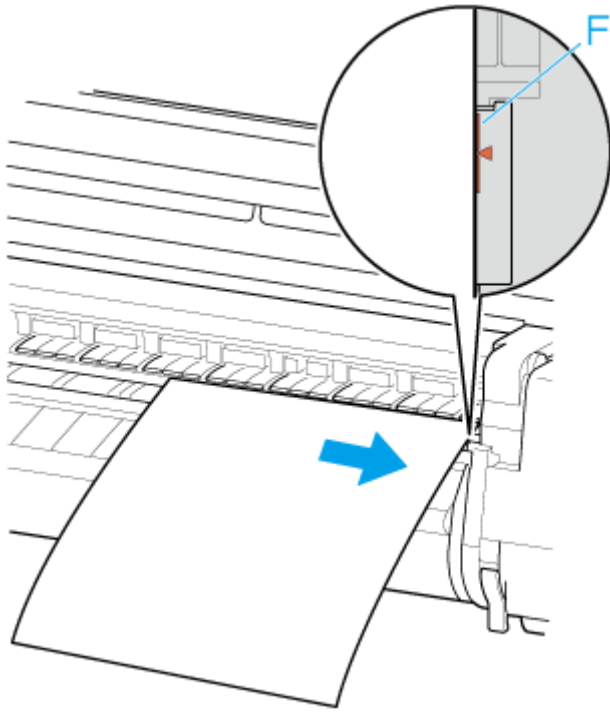

7. Align the back edge of the inserted paper with the front edge of the back paper alignment line (G).

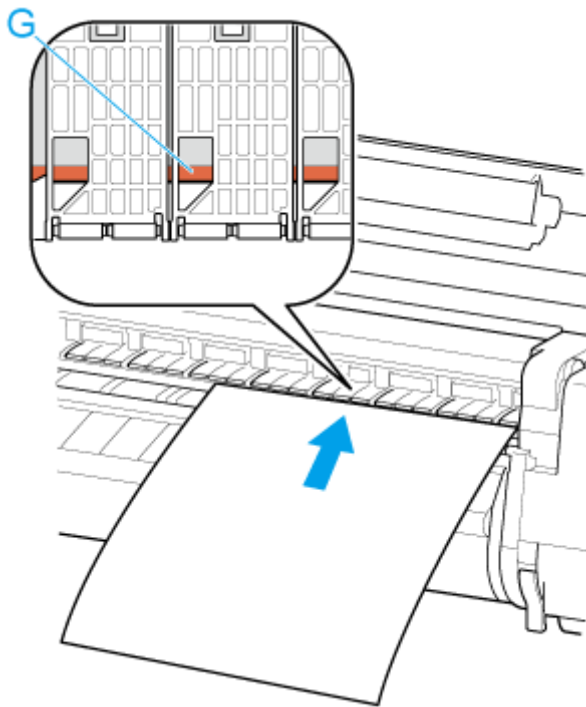

»» Important

- Load the sheet so that it is parallel to the right paper alignment line (F). Loading paper askew will cause an error.
- Warped paper may rub against the print head. Straighten paper if it is warped before loading.

▶▶▶ Note

- You can also align the cut sheet based on its near edge. In this case, load the cut sheet aligning its near edge with marks (H) on the platen and the right edge with the right-side paper alignment line (F).

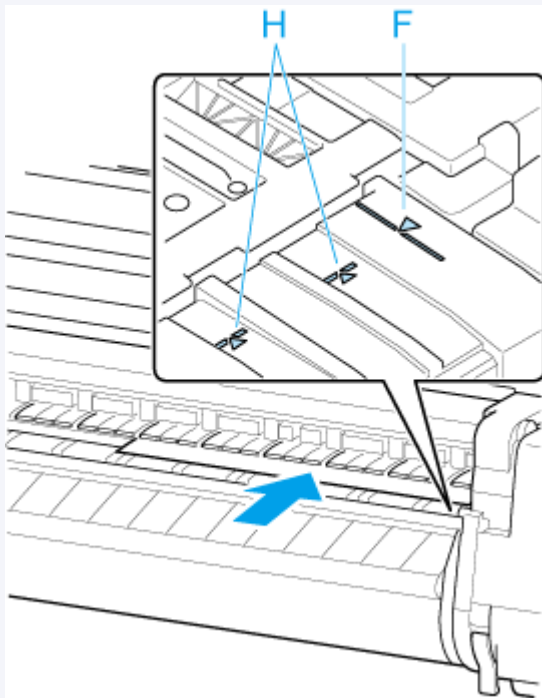

- You can adjust the vacuum strength holding the paper against the platen when the release lever is up. If it is difficult to load the paper, tap **Suction** on the touch screen and adjust the vacuum strength. You can adjust the vacuum strength to 5 levels.

However, even if you increase the suction, it may not be sufficient to hold some types of paper against the platen well. In this case, use your hand to load the paper.

- Sheets are held in place by suction through holes on the platen. Although the suction may produce a noise when paper is loaded in some positions, it does not indicate a problem. If the noise is distracting, try moving the paper over slightly to the left or right (up to 0.04 inch (1 mm)) while keeping it parallel to the paper alignment line.
- The suction remains on for about 30 seconds during loading. If you cannot finish loading a sheet during this time, pull the sheet away and reinsert it to start the suction again.

8. Lower release lever and close top cover.

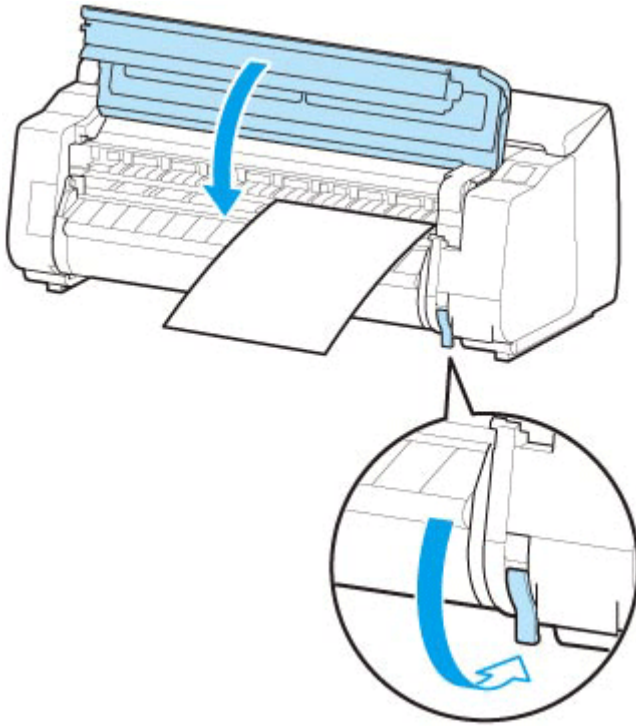

►►► **Note**

- If a print job has been received in advance, follow the touch screen to start printing after loading the paper.

9. Select the type of loaded paper and select **OK.**

Paper feeding will start.

►►► **Note**

- For details on media types that you can select, see "Paper Information List."

Removing Sheets

Remove sheets from the printer as follows.

1. Select the paper setting display area on Home screen.

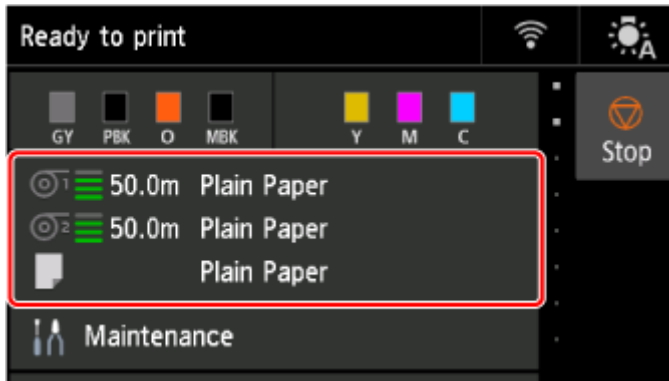

2. Select the **Manual** area.

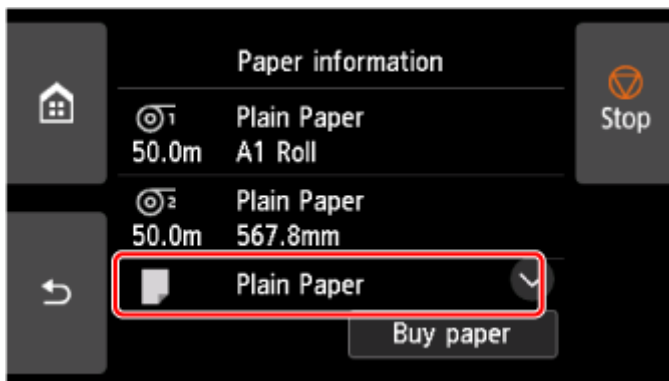

3. Select **Remove paper**.
4. Check the contents of the message and select **Yes**.
5. When instructions for removing sheet appear on touch screen, lift release lever while holding sheet, and remove sheet.

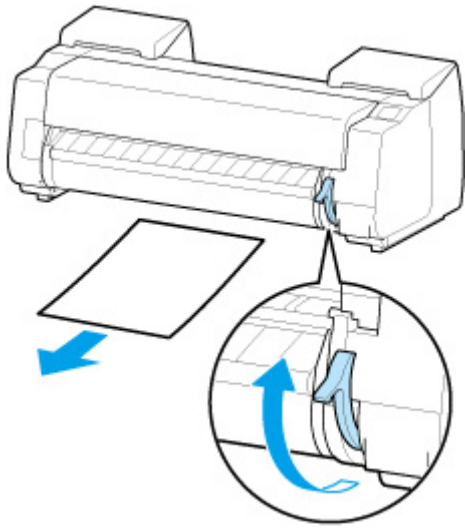

6. Lower release lever.

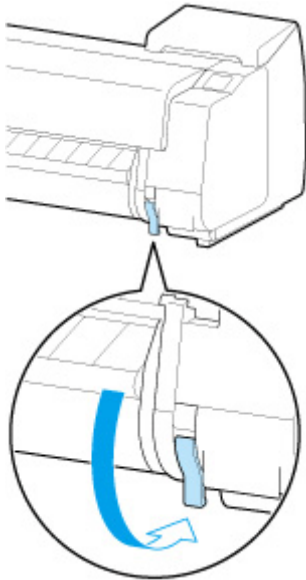

Printing From a Desired Starting Point

Print on sheets from a desired starting point as follows.

Setting Detect paper width to Disable

1. Select  **Printer settings** on HOME screen.
2. Select **Paper-related settings**.
3. Select **Advanced paper settings**.
4. Select the paper type.
5. Select **Detect paper width**.
6. Select **Disable**.

Load paper in the desired position to start printing from

1. Load paper.
 - ➔ [Loading Sheets in the Printer](#)
2. Check the contents of the message and select **Keep it disabled and continue**.

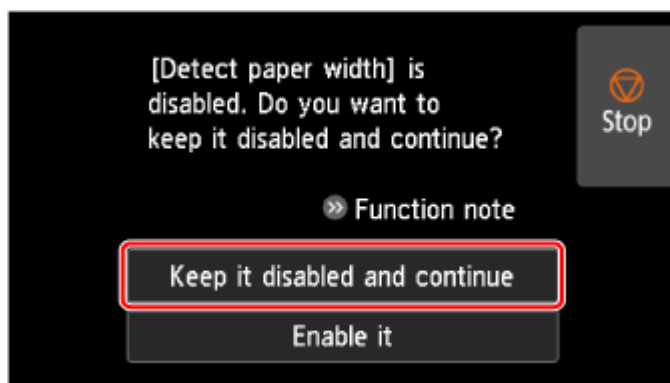

3. Open top cover.

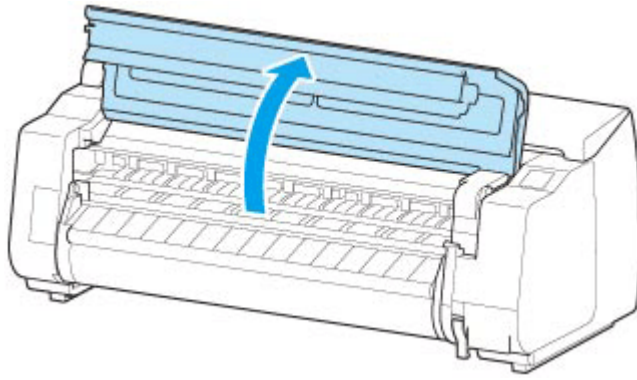

4. Lift release lever.

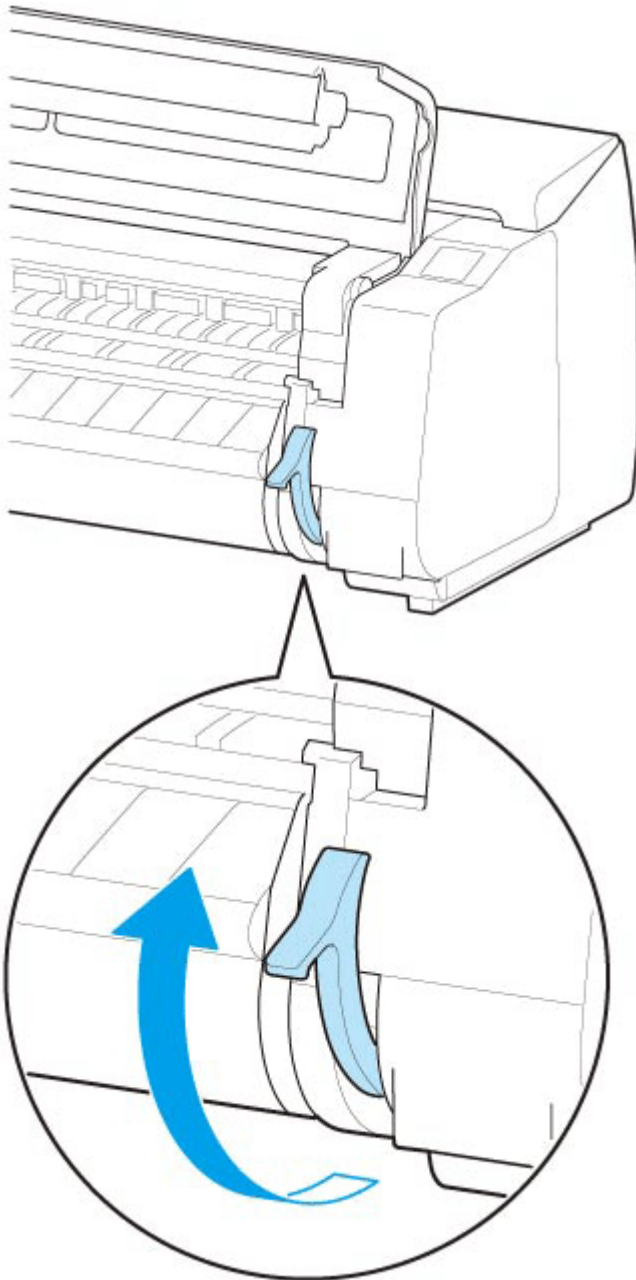

5. Load paper keeping right edge of paper aligned with extended line of paper alignment line (A) on right side of printer and position from which to start printing aligned with groove (B) at far end of platen.

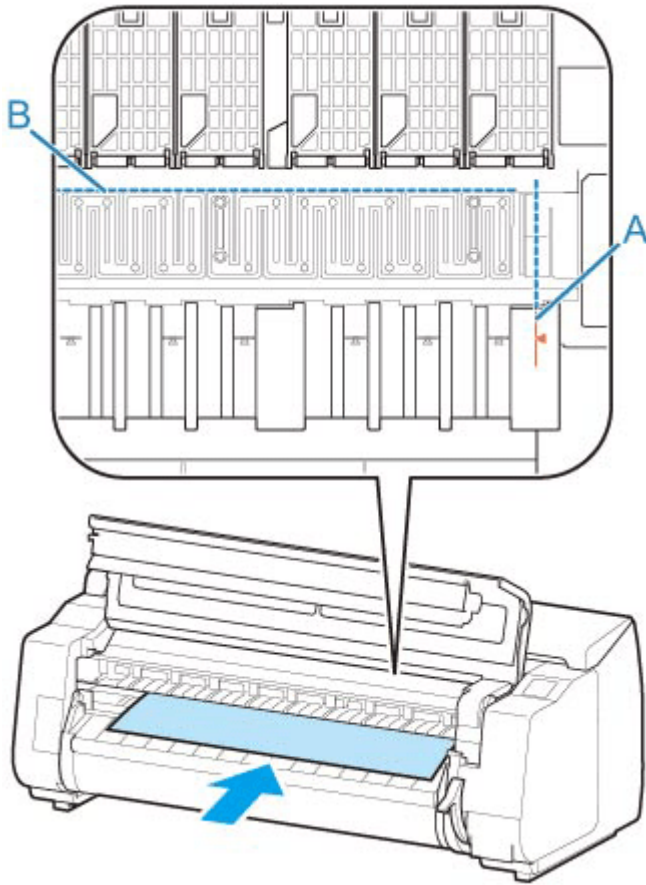

6. Lower release lever and close top cover.

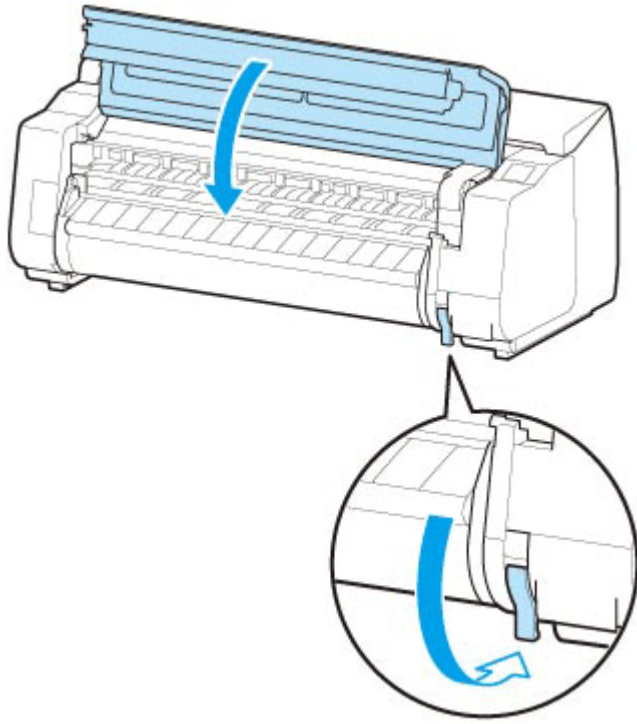

7. When screen for selecting paper size appears, select size of paper loaded.

Paper Settings

- **Changing the Type of Paper**
- **Specifying the Paper Length**
- **Keeping Track of the Amount of Roll Paper Left**
- **Specifying the Cutting Method for Rolls**
- **Cutting the Leading Edge of Roll Paper Automatically**
- **Reducing Dust from Cutting Rolls**
- **Specifying the Ink Drying Time**
- **Specifying the Amount of Extension for Borderless Printing**

Changing the Type of Paper

Follow these steps to change the type of paper specified on the printer after you have loaded paper.

▶▶▶ Note

- This printer has the ability to estimate the media type by the data read by the sensor when the paper is set. If you continue to use this feature, you will learn the data that you read and the accuracy of the media type estimation. If you continue to use multiple media types, this feature will reduce the need to select the media type each time you set the paper.

➔ [Media type selection method](#)

- If you continue using the same type of paper and set **Media type selection method** to **Use current media type**, when you load paper, the media type selected before **Use current media type** was set is selected automatically, eliminating the need to set the media type.

➔ [Media type selection method](#)

▶▶▶ Important

- For best printing results, the printer fine-tunes the print head height and the feed amount for each type of paper. Be sure to select the type of paper to use correctly before printing.

1. Select paper settings display area on Home screen.

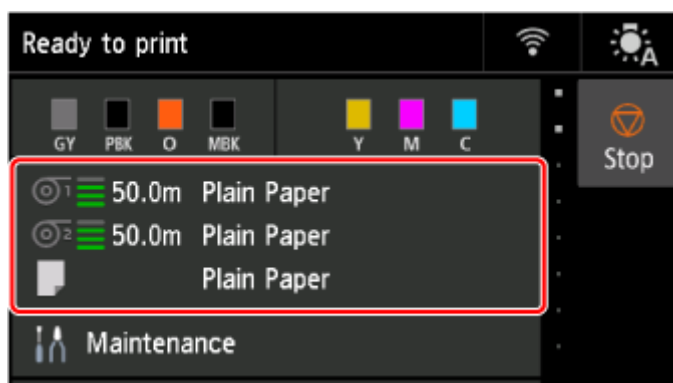

2. Select paper source.



3. Select **Paper settings**.

4. Select **Type**.

5. Select media type of roll paper loaded in printer.

»» Important

- Be sure to select the correct paper type. If this setting does not match the loaded paper, it may cause feed errors and affect printing quality.

»» Note

- For details on media types, see "Paper Information List."
- When the release lever is operated, the settings automatically return to the last selected media type.

6. Select **Register**.

Specifying the Paper Length

When changing the length of paper after the paper has been advanced, specify the length as follows.

▶▶▶ Note

- Specify the roll paper length when you have set **Manage remaining roll amount** to **Barcodes**.

➔ [Keeping Track of the Amount of Roll Paper Left](#)

1. Select paper settings display area on Home screen.

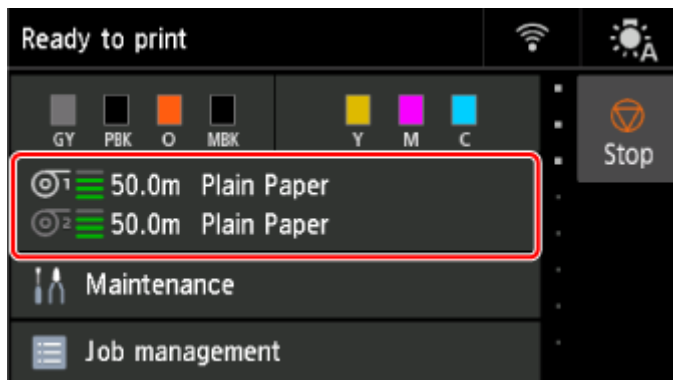

2. Select paper source.

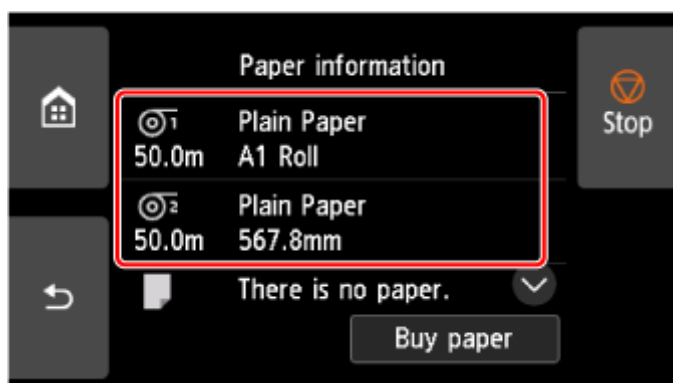

3. Select **Paper settings**.
4. Select **Length**.
5. Enter roll paper length and select **OK**.
6. Select **Register**.

Keeping Track of the Amount of Roll Paper Left

There are two methods of managing the amount of roll paper left: by using the barcode and by estimating the amount of roll paper left.

Managing by the Barcode for the Amount of Roll Paper Left

When you set **Manage remaining roll amount** to **Barcodes**, the amount of remaining roll paper and the media type information are printed as a barcode and text when the paper is removed. When **Manage remaining roll amount** is set to **Barcodes** and you load roll paper with a printed barcode, the media type and remaining amount are automatically detected after the roll paper is loaded. The barcode will be cut off after it has been read.



Important

- If the barcode on the roll is not detected, enter the type and length of paper on the operation panel. The length of the paper at this time can be set in **Roll length (change default)**.

➔ [Setting the Default Value of the Amount of Roll Paper Left when Managing by the Barcode](#)

Follow the steps below when setting **Manage remaining roll amount** to **Barcodes**.



1. Select **Printer settings** on Home screen.
2. Select **Paper-related settings**.
3. Select **Manage remaining roll amount**.
4. Select **Barcodes**.
5. Enter roll paper length and select **OK**.

Important

- When selecting **Enable** in **Roll paper auto feed**, the screen for checking the length of the roll paper is displayed for only 5 seconds.

Note

- The length of the roll paper to be displayed can be set in **Roll length (change default)**.
- ➔ [Setting the Default Value of the Amount of Roll Paper Left when Managing by the Barcode](#)

6. Select the timing when the warning message appears.

Setting the Default Value of the Amount of Roll Paper Left when Managing by the Barcode

When you select **Barcodes** in **Manage remaining roll amount** and if you feed roll paper on which no barcode is printed, such as new roll paper, the screen to enter the roll paper length (remaining amount) appears.

In this screen, the length (remaining amount) of default value appears. If the length is not correct, enter a correct length.

When you want to change the length (remaining amount) of default value, follow the steps below.

1. Select paper settings display area on Home screen.

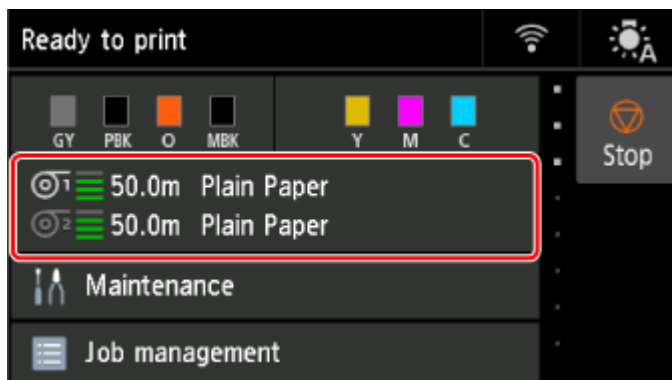

2. Select paper source.

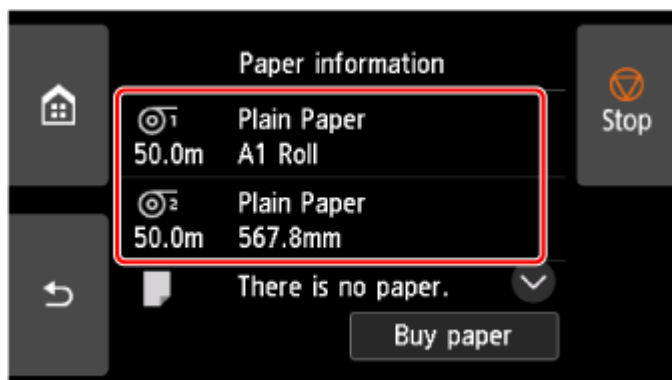

3. Select **Paper settings**.
4. Select **Advanced**.
5. Select **Roll length (change default)**.
6. Enter roll paper length and select **OK**.

Managing by Estimating the Amount of Roll Paper Left

When you set the **Manage remaining roll amount** to **Auto estimate**, the remaining amount of roll paper is estimated and displayed in the Operation panel. The barcode is not printed.

When paper runs out, the printer records the estimated remaining roll amount. Any discrepancy will be used to make the estimated remaining roll amount more accurate the next time you load the same paper.

»» Important

- If the type of paper is not selected correctly, the amount of roll paper left may not be estimated correctly.
- There is an error in the estimated amount of paper remaining, and it may be out of paper during printing.
- When using the paper which is not listed in "Paper Information List" set **Paper thickness** and **Paper core outer diameter** under **Advanced paper settings** or Media Configuration Tool. To estimate the remaining amount of paper, **Paper thickness** and **Paper core outer diameter** must be set correctly.
 - ➔ Paper Information List
 - ➔ Media Configuration Tool Guide

Specifying the Cutting Method for Rolls

▶▶▶ Note

- **Automatic cut** and **Eject cut** are valid only when you have selected **Automatic Cutting>Yes** in the printer driver.
 - ➔ Cutting Roll Paper after Printing (Windows)
 - ➔ [Cutting Roll Paper after Printing](#) (macOS)
- **Eject cut**, printing does not resume after a series of jobs have been printed continuously until the roll is cut.
- For continuous printing with **User cut**, select **Yes** or **Print Cut Guideline** in **Automatic Cutting** in the printer driver.
- **Eject cut** or **User cut** is the preset selection in **Cutting mode** for some types of paper. For this paper, we recommend keeping the preset cutting mode.
- If documents printed using **Automatic cut**, **Eject cut**, or **User cut** are short, rolls are advanced a specific amount before cutting to prevent problems with cutting and paper ejection. This may create a wider bottom margin, in some cases.

1. Select paper settings display area on Home screen.

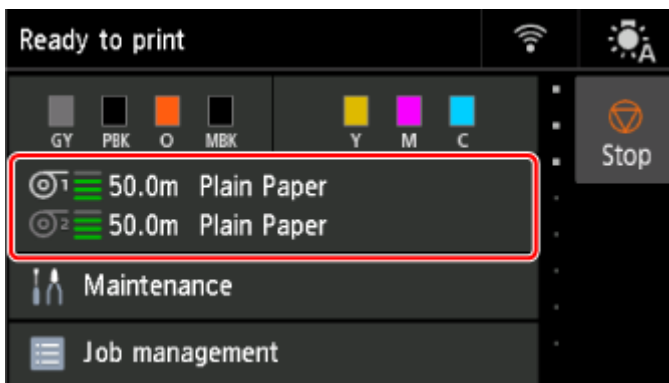

2. Select paper source.

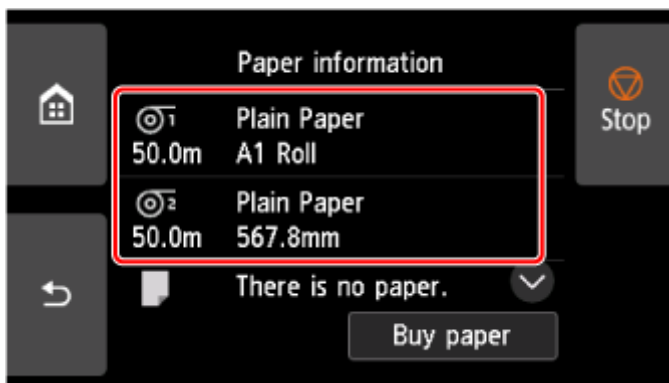

3. Select **Paper settings**.

- 4. Select **Advanced**.
- 5. Select **Cutting mode**.
- 6. Select a setting from the menu.

Automatic cut

Select this to cut the roll paper automatically with the cutter blade.

Eject cut

Select this to move the cutter by operation panel operation and cut paper. With **Automatic cut**, the paper drops and may rub against the basket, resulting in damage to the print surface, but you can cut using this method and supporting the paper so that it does not drop to avoid damage to the paper. Also, you can prevent paper that has not dried from dropping by visually checking the ink has dried, and then cutting the paper.

After printing, select **Cut paper** and cut the roll paper on the cutter blade.

➔ [Cutting Roll Paper after Printing](#)

User cut

Select this if the paper cannot be cut on the cutter blade. When **Do you want to set to detect the leading edge of the paper?** is displayed, select **Detect (recommended)**.

Cut each page from the roll using scissors.

➔ [Cutting Roll Paper after Printing](#)

»» Important

- For paper of which the leading edge rubs the print head, set the detection of paper leading edge to **Do not detect** and align paper's leading edge with position (A).

➔ [Feeding Roll Paper Manually](#)

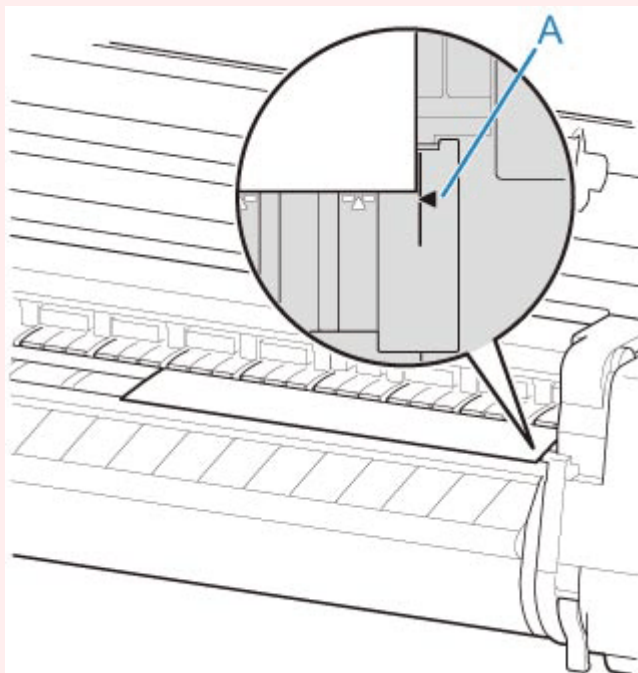

- If you set the detection of paper leading edge to **Do not detect**, a margin of about 4.0 inches (10 cm) is created at the paper leading edge when printing starts.

- When the detection of paper leading edge is set to **Do not detect**, printing will start at the position at which the roll was set for the first printing after replacing a roll. Thus, the margin of the paper leading edge will enlarge.

Cutting the Leading Edge of Roll Paper Automatically

If the leading edge of the paper is cut crooked or is not cut straight when roll paper is loaded, it will not print correctly. If this happens, you can cut the leading edge of the paper straight when loading a paper roll by using **Trim edge first** in the operation panel menu.

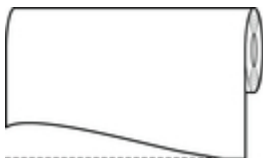

Follow these steps to change the **Trim edge first** setting.

1. Select paper settings display area on Home screen.

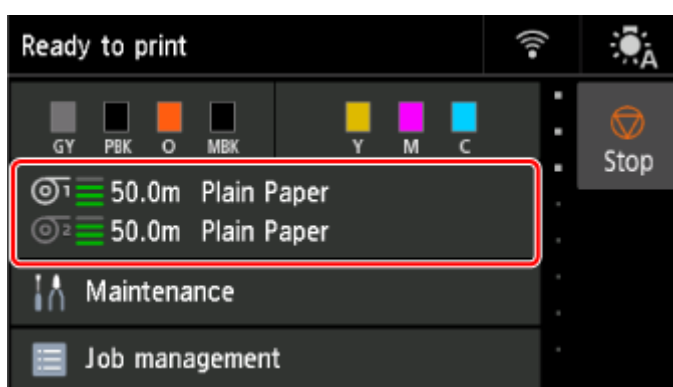

2. Select paper source.

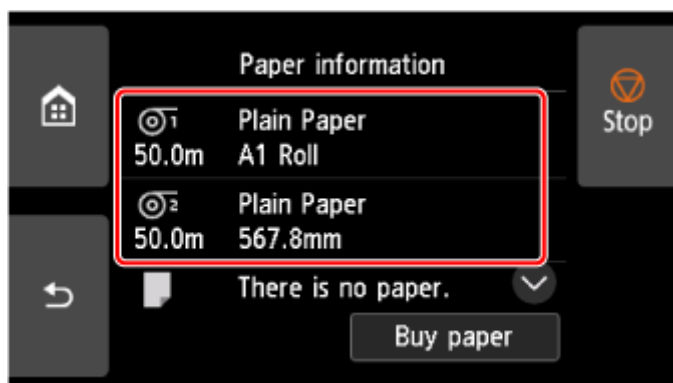

3. Select **Paper settings**.
4. Select **Advanced**.
5. Select **Trim edge first**.
6. Select a setting from the menu.

This setting takes effect the next time you load a roll.

Auto

If the leading edge of the paper is cut crooked and is not cut straight when loading roll paper, cut the leading edge straight and eject the fragment of paper to prevent printing on the platen and soiling the printer.

Off

The edge is not cut and scraps are not removed.

On(Preset Length)

The paper is cut at the pre-defined length when the roll paper is loaded. The pre-defined length depends on the type of paper. For more information, see "Paper Information List."

➡ Paper Information List

On(Input Length)

The paper is cut at the specified length when the roll paper is loaded. The range of lengths that can be specified depends on the type of paper.

Manual

The amount to cut from the leading edge of paper can be adjusted by using the operation panel.

To cut the paper after adjusting, select **Cut paper** and select **Yes**.

After cutting the paper, select **Complete paper loading**.

▶▶ Note

- If you do not select **Complete paper loading** after cutting the paper, you cannot print the next job.

Reducing Dust from Cutting Rolls

If the paper tends to generate dust when cut, such as with Backlit Film, you can reduce flying dust by setting **Cut-dust reduction** to **ON** from the operation panel menu, which will coat the leading and trailing edges of the printed document with ink. As a result, you can reduce problems with the print head. You can set **Cut-dust reduction** according to the media type.



A: The ink is coated.

B: Cut Position

▶▶▶ Important

- Do not set **Cut-dust reduction** to **ON** for paper that wrinkles easily, such as **Plain Paper** or lightweight paper. If not cut properly, the paper may jam.
- Borderless printing is not available when **Cut-dust reduction** is set to **ON**. When performing borderless printing, set **Cut-dust reduction** to **OFF**.

Follow these steps to set **Cut-dust reduction** to **ON**.

1. Select paper settings display area on Home screen.

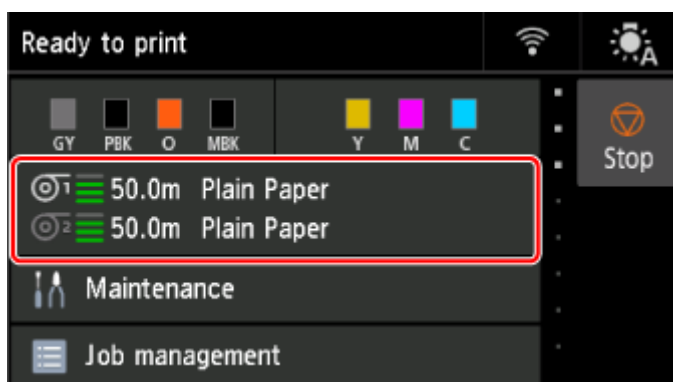

2. Select paper source.

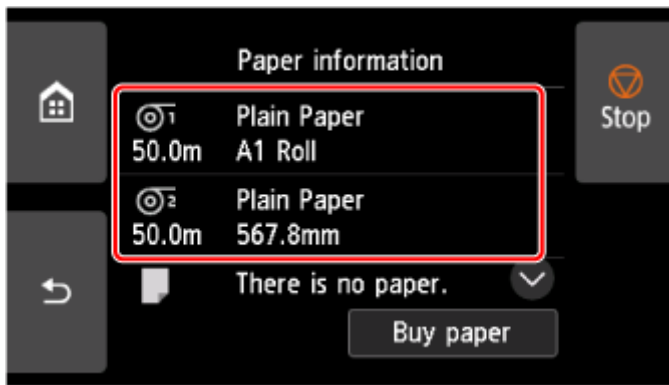

3. Select **Paper settings**.
4. Select **Advanced**.
5. Select **Cut-dust reduction**.
6. Select **ON**.

Specifying the Ink Drying Time

When you are using paper that takes longer for ink to adhere, ink may be transferred onto the paper surface during ejection, soiling it. In that case, you may be able to improve the condition by setting the time to wait for the ink to dry after printing.

▶▶▶ Important

- Printer settings are applied when the ink drying time is not set in the printer driver. If the ink drying time is set in the printer driver, that setting has priority.
 - ➔ Main Tab Description (Windows)
 - ➔ [Advanced Paper Settings](#) (macOS)

▶▶▶ Note

- If the cutter touches the print surface on which the ink is not dry, the paper surface may become scratched or soiled, or the paper surface may rub when the paper falls and the surface may become soiled.

To wait for the ink to dry without allowing printed materials to fall after printing, set **Cutting mode** on the printer menu to **Eject cut**.

- ➔ [Specifying the Cutting Method for Rolls](#)

Pausing Between Scans

Specify the waiting time between printing one scan and printing the next one. You can set the drying waiting time and the target area where the waiting time occurs.

1. Select paper settings display area on Home screen.

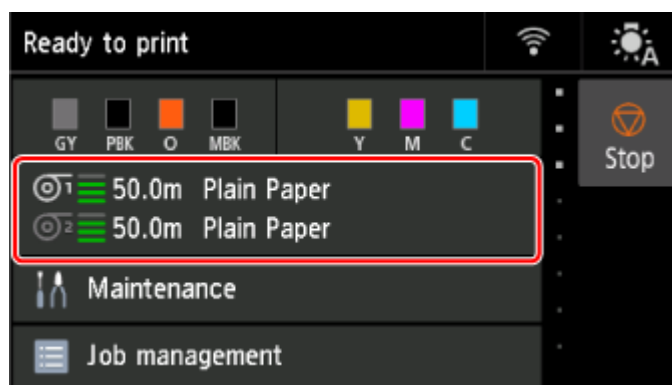

2. Select paper source.

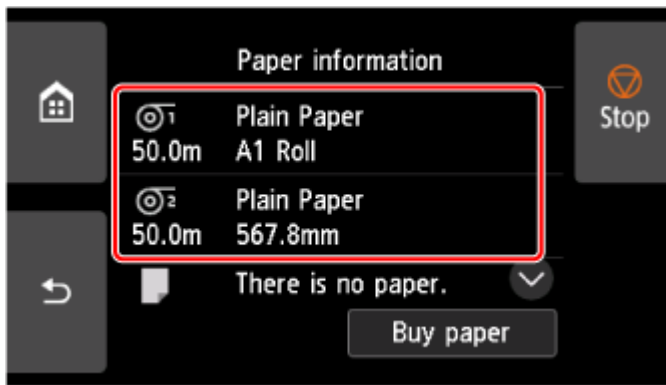

3. Select **Paper settings**.
4. Select **Advanced**.
5. Select **Pause between scans**.
6. Select **Ink drying wait time**.
7. Select a setting from the menu.

Pausing Between Pages

Specify the waiting time between printing one page and ejecting the paper. If there is a next page, it will be printed after the ink drying time has elapsed.

1. Select paper settings display area on Home screen.

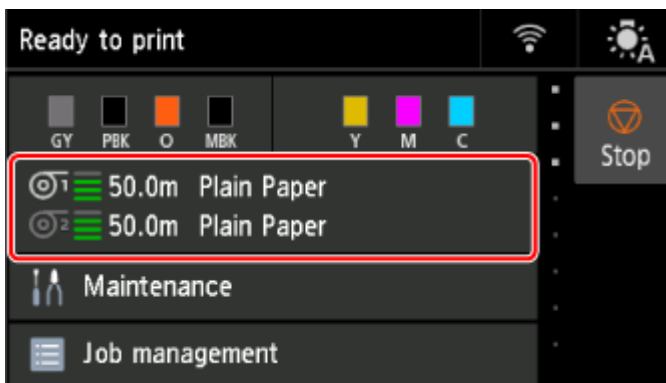

2. Select paper source.

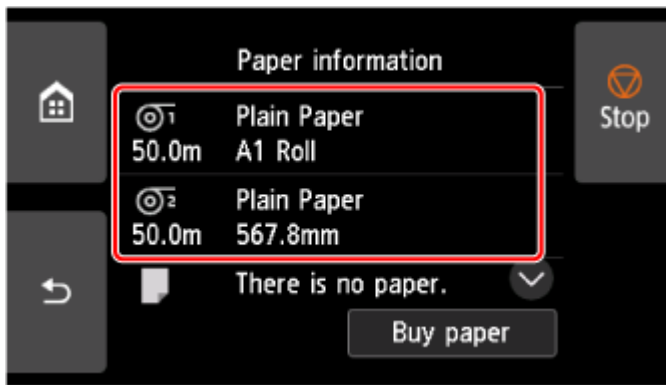

3. Select **Paper settings**.
4. Select **Advanced**.
5. Select **Pause between pages**.
6. Select a setting from the menu.

Pausing on the last page during take-up

When you use a roll unit mode as a take-up, you set the wait time after you print the last page. If you have the next page to print, cancel the drying time waiting and print.

1. Select paper settings display area on Home screen.

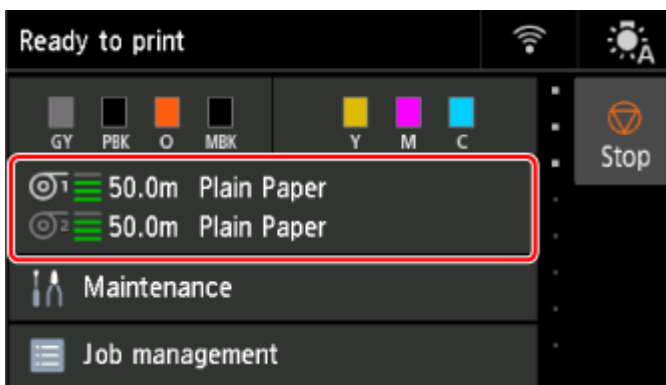

2. Select paper source.

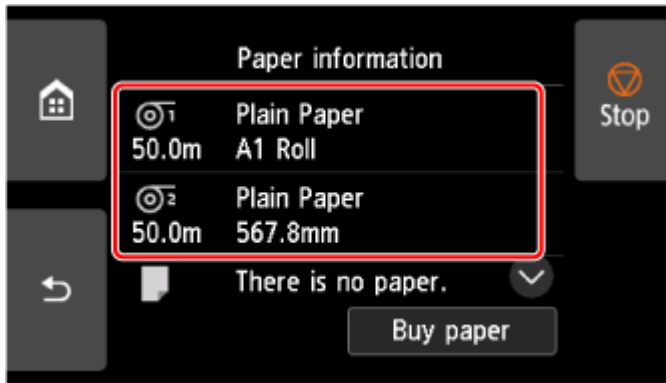

3. Select **Paper settings**.
4. Select **Advanced**.
5. Select **Pause on last page take-up**.
6. Select a setting from the menu.

»» Note

- Under **Pause timing priority** you can specify the prioritized pause time when the roll unit is used as a take-up device.
To prioritize the waiting time between printing each page and paper ejection, select **Between pages**.
To prioritize the waiting time after printing the last page, select **On last page**.

Specifying the Amount of Extension for Borderless Printing

Borderless printing may leave margins on the left and right sides of the paper or soil the back of the paper. Adjusting the amount of extension may improve these problems.

Each paper width is shown as being a recommended width for borderless printing (**Paper with recommended width**), or as having sufficient width for borderless printing (**Paper of sufficient width**). The procedure for specifying the amount of extension differs depending on **Paper with recommended width** and **Paper of sufficient width**.

- ➔ [Specifying Amount of Extension for Paper with recommended width.](#)
- ➔ [Specifying Amount of Extension for Paper of sufficient width.](#)

For more information on a paper width recommended for borderless printing, see [Paper Sizes](#).

Specifying Amount of Extension for Paper with recommended width.

1. Select paper settings display area on Home screen.

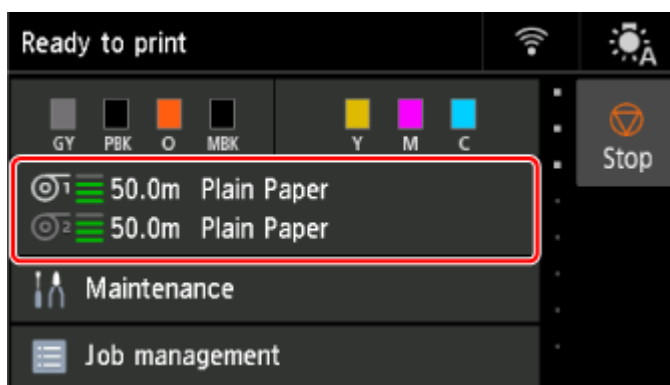

2. Select paper source.

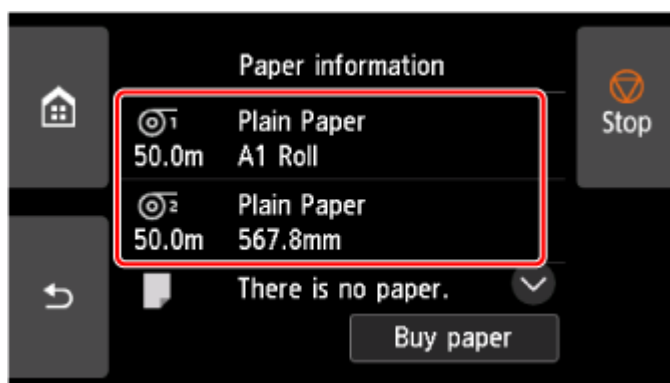

3. Select **Paper settings**.
4. Select **Advanced**.
5. Select **Extension for borderless printing**.

6. Select **Paper with recommended width**.

7. Select amount of extension.

Select **Large**, **Standard**, or **Small**.

▶▶▶ **Note**

- When selecting **Large**, the printed area will be wider. Select this if there are margins.
- When selecting **Small**, the printed area will be narrower. Select this if there are stains.

Specifying Amount of Extension for Paper of sufficient width.

In case of **Paper of sufficient width**, the width of the original is set to be slightly smaller than the paper, and there are margins on the left and right. You can reduce the margins by increasing the amount of extension.

On the other hand, if the amount of extension is too large, the back side of the paper will be easily soiled with the overflowed ink. When performing borderless printing with specifying the amount of extension for **Paper of sufficient width**, clean the platen regularly.

➔ [Cleaning Inside the Top Cover](#)

1. Select paper settings display area on Home screen.

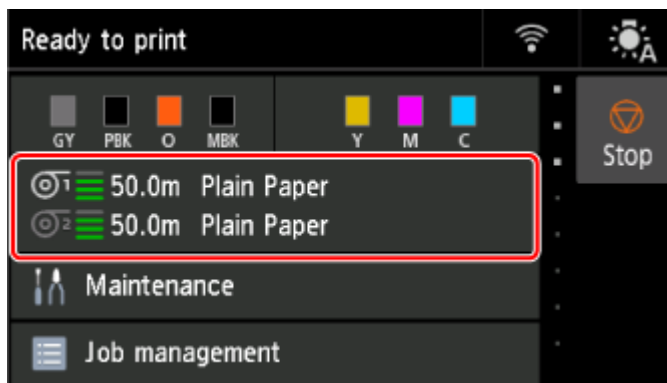

2. Select paper source.

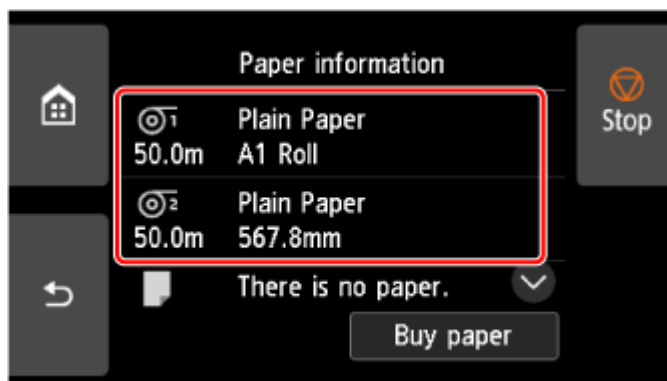

3. Select **Paper settings**.

4. Select **Advanced**.
5. Select **Extension for borderless printing**.
6. Select **Paper of sufficient width**.
7. Select **Sample of extension amounts**.
8. Confirm displayed message and select **Yes**.
The alignment pattern for each adjustment value is printed.
9. Select the adjustment value.

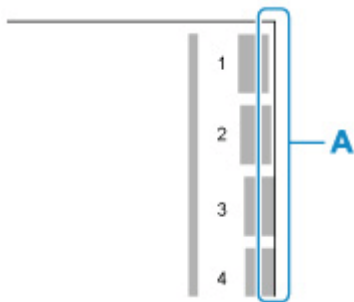

Check the paper edge (A) of the 1st to 8th on the output pattern and select the number that has the appropriate amount of extension.

▶▶▶ Note

- The larger the set adjustment value, the wider the printed range.
- After setting, we recommend to perform borderless printing to check the margin status.
If the margin remains, set a larger adjustment value. If the back of the paper is soiled, set a smaller adjustment value.
- After printing alignment pattern and borderless printing for confirmation, we recommend to clean the platen.
➡ [Cleaning Inside the Top Cover](#)

Information about Paper

- **Paper Sizes**
- **Paper Information List**
- **Updating paper information**
- **Using Paper Other Than Genuine Paper and feed confirmed Paper**
 - Printing on Paper Other Than Genuine Paper and feed confirmed Paper Using Existing Settings
 - Printing on Paper Other Than Genuine Paper and feed confirmed Paper by Adding a Media Type
- **Managing Paper Information on Printer Using Media Configuration Tool**

Paper Sizes

Rolls

Rolls that meet the following conditions are supported.

- Outer diameter is 6.7 inches (170 mm) or less
- Inner diameter of paper core: 2 or 3 inches
- Printing side out

Roll Paper Width	GP-6600S / GP-566S : 60.00 in. (1524.0 mm) to 6.00 in. (152.4 mm) GP-4600S / GP-546S : 44.02 in. (1118.0 mm) to 6.00 in. (152.4 mm) GP-2600S / GP-526S : 24.02 in. (610.0 mm) to 6.00 in. (152.4 mm)
Roll Paper Width recommended for borderless printing(*1,*2)	60 in Roll (1524.0mm) 54 in Roll (1371.6mm) 50 in Roll (1270.0mm) 44 in Roll (1117.6mm) 42 in Roll (1066.8mm) B0/B1 Roll (1030.0mm) 36 in Roll (914.4mm) A0/A1 Roll (841.0mm) B1/B2 Roll (728.0mm) 24 in Roll (609.6mm) A1/A2 Roll (594.0mm) B2/B3 Roll (515.0mm) 17 in Roll (431.8mm) 14 in Roll (355.6mm) 10 in Roll (254.0mm)
Minimum Paper Length	4.00 in. (101.6 mm) Excludes cloth/canvas paper.
Maximum Printable Length	59 feet (18 m) depends on the OS and application.
Thickness	3 mil (0.07 mm) to 31 mil (0.8 mm)

*1:Borderless printing may not be available depending on the media type. For details on media types that can be used for borderless printing, see "Paper Information List."

*2:You can perform borderless printing without specifying **Roll Paper Width** recommended for it. As opposed to standard borderless printing, there will be a small margin on the left and right because the paper width is set a little bit smaller than the width of the document.

Sheets

Sheets of the following sizes are supported.

Sheet Width	GP-6600S / GP-566S : 60.00 in. (1524.0 mm) to 6.00 in. (152.4 mm) GP-4600S / GP-546S : 44.02 in. (1118.0 mm) to 6.00 in. (152.4 mm) GP-2600S / GP-526S : 24.02 in. (610.0 mm) to 6.00 in. (152.4 mm)
Minimum Paper Length	8.00 in. (203.2 mm)
Maximum Printable Length	5.2 feet (1.6 m)
Thickness	3 mil (0.07 mm) to 31 mil (0.8 mm)

▶▶▶ Note

- For details on non-standard sizes, see "Setting Paper Dimensions (Custom Size)" (Windows) or "[Setting Paper Dimensions \(Custom Size\)](#)" (macOS).
- Borderless printing is not supported on sheets.

Updating paper information

You can update the printer's media information to the latest information by applying the latest version of the Media Information File.

For details on the procedure for applying the Media Information File, refer to the following.

➔ [Media Configuration Tool Guide](#)

»» Important

- If you are using the Media Configuration Tool, the new Media Information File is downloaded automatically when released on the Canon website. A computer connected to the Internet is required to download the Media Information File.
- Even if you are not using the printer driver, you should install the Media Configuration Tool in order to register the media types for your region in the printer.

Using Paper Other Than Genuine Paper and feed confirmed Paper

When using this printer to print on paper other than genuine Canon paper and feed confirmed paper, use paper that meets the following conditions.

- Paper where the size is described in "[Paper Sizes](#)"
- Paper where bleeding and ink overflow does not occur when printing
- Paper that does not warp severely when loading the paper or printing

▶▶▶ Note

- For Canon genuine paper/feed confirmed paper, see "Paper Information List."

▶▶▶ Important

- If you use paper other than Canon genuine paper and feed confirmed paper, Canon provides absolutely no guarantees regarding print quality or paper feed properties.

After loading the paper in the printer, select the media type in the operation panel and printer driver and then perform the printing. For the media type, you can select easily from existing settings or you can create and use settings for the paper you are using.

Printing Using Existing Settings

You can print easily by selecting from existing settings provided in the operation panel and printer driver.

➔ [Printing on Paper Other Than Genuine Paper and feed confirmed Paper Using Existing Settings](#)

Printing Using Additional Settings

You can use the function to add custom paper in the Media Configuration Tool to create settings suitable for paper other than genuine paper/output confirmation paper you are using. You can add the created settings to the printer operation panel and printer driver as a new paper type for printing.

➔ [Printing on Paper Other Than Genuine Paper and feed confirmed Paper by Adding a Media Type](#)

Printing on Paper Other Than Genuine Paper and feed confirmed Paper Using Existing Settings

You can easily print on paper other than genuine Canon paper and feed confirmed paper without making complicated settings by selecting the existing settings provided in the operation panel and printer driver depending on the media type you are using. The existing settings consist of general-purpose paper settings provided for different media types.

▶▶▶ Important

- The Canon genuine paper settings provided in the operation panel and printer driver are optimized for Canon genuine paper. If these settings are selected for printing on paper other than Canon genuine paper, the ink may bleed or the print head may rub against the paper. To easily print on paper other than Canon genuine paper and feed confirmed paper, we recommend that you select one of the following general-purpose paper settings.

▶▶▶ Note

- For the available paper types, see "Paper Information List."
- For instructions on selecting the media type with the operation panel, see "[Changing the Type of Paper](#)". For instructions on selecting the media type with the printer driver, see "Main Tab Description" (Windows) or "[Quality & Media](#)" (macOS).

Choosing General-Purpose Paper Settings

These settings anticipate a wide variety of paper other than Canon genuine paper and feed confirmed paper, and, therefore, these settings make it difficult for bleeding ink and print head rubbing to occur. For details on the relationships between the conditions of paper other than Canon genuine paper and feed confirmed paper and the media type to select, see "Paper Information List."

▶▶▶ Note

- If you cannot obtain the desired results by selecting the general-purpose paper settings, use the custom paper adding function in Media Configuration Tool to create settings suitable for the paper you are using. For details, see "[Printing on Paper Other Than Genuine Paper and feed confirmed Paper by Adding a Media Type](#)."

Printing on Paper Other Than Genuine Paper and feed confirmed Paper by Adding a Media Type

Media Configuration Tool provides a function for adding custom paper for better print quality and improved paper feed properties when printing on paper other than Canon genuine paper/feed confirmed paper than when printing with general-purpose settings. You can use this function to configure settings such as the amount of ink used and the height of the print head according to the characteristics of the paper being used, and thereby realize higher print quality. Also, you can add the settings created with this function as a new media type to the operation panel and printer driver.

For details on Media Configuration Tool, refer as follows.

➡ Media Configuration Tool Guide

▶▶ Important

- For details on how to select the added media type in the operation panel, see "[Changing the Type of Paper.](#)"
- You can select the media type to be used in printing in the **Main** sheet (Windows) or **Quality & Media** (macOS) in the printer driver. For details, see "Main Tab Description" (Windows) or "[Quality & Media](#)" (macOS).
- We recommend that you use an ICC profile created using commercially available profile creation software to perform color management accurately on paper other than Canon genuine paper and feed confirmed paper. You can register the ICC profile you created when creating a custom paper with Media Configuration Tool. See "Adding Custom Paper" in Media Configuration Tool Guide.

Settings

▶ **Changing Settings from Operation Panel**

- Home Screen Menu Composition
- Menu Structure
- Setting Items on Operation Panel
- Setting Administrator Password on Operation Panel
- Erasing Data on Printer's Hard Disk
- Status Print

▶ **Changing Printer's Setting Using Web Browser**

- Start up Remote UI
- Changeable Setting Items Using Remote UI
- Setting Passwords Using Remote UI
- Registering Printer's Root Certificate to Web Browser for SSL Communication
- Registering Printer's Root Certificate to Local Computer for SSL Communication
- Generating Server Certificate
- Setting Mail Server
- Receiving Printer Status by E-mail

▶ **Migrating Printer's Setting**

▶ **Initializing Printer's Setting**

▶ **Network Setting**

- Printer Connection Methods
- Another Printer Found with Same Name
- Printing Network Settings
- Network Status and Troubleshooting
- Checking Printer Connection Status Using Wi-Fi Connection Assistant
- Sharing the Printer on a Network (Windows)

- Sharing the Printer on a Network (macOS)

Changing Settings from Operation Panel

- **Home Screen Menu Composition**
- **Menu Structure**
- **Setting Items on Operation Panel**
- **Setting Administrator Password on Operation Panel**
- **Erasing Data on Printer's Hard Disk**
- **Status Print**

Home Screen Menu Composition

After the printer starts up, the HOME screen appears on the touch screen.

From the HOME screen, you can check the printer status and select the maintenance, paper operations, settings, and other menus.

➔ [Basic Touch Screen Operations](#)

➔ [Icons on Touch Screen](#)

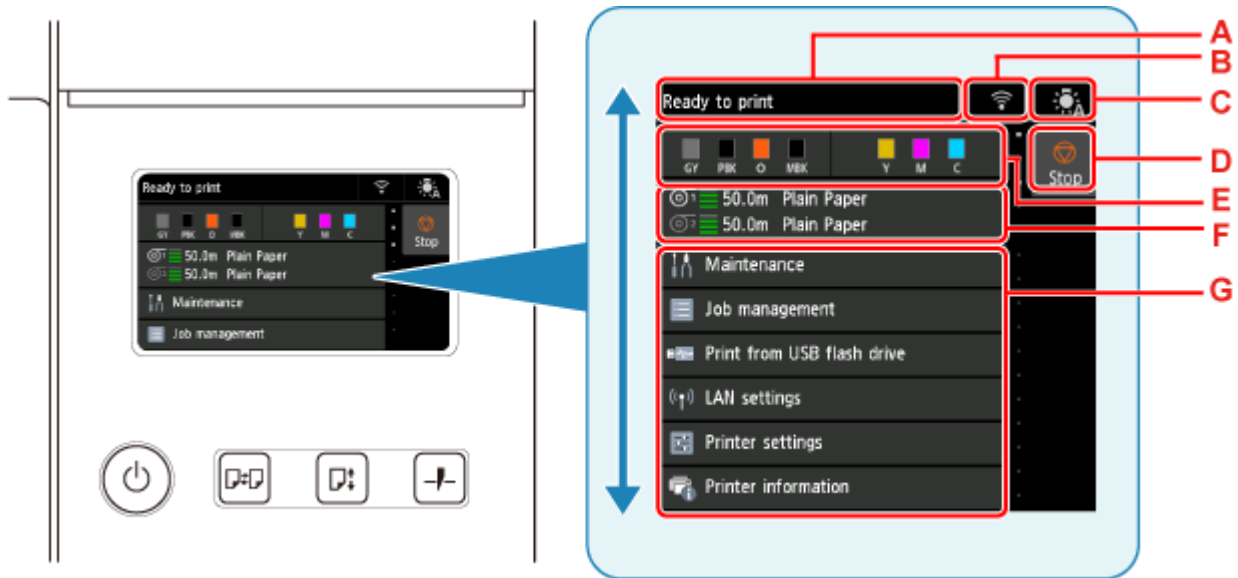

A: Printer Information Display Area

Displays the printer status, messages, and other information. Select this item when a message appears to view the message on the list screen and to jump to the screen with detailed information and operations.

➔ [Notification Messages](#)

B: Network

Displays the current network status. Select to display the basic network information or to change the network settings.

The icon differs depending on the network of use or the network status.



Wi-Fi is enabled and the printer is connected to the wireless router.

➤➤➤ Note

- Depending on the signal state, the icon will change.



(Signal strength: 81 % or more): You can use the printer over a Wi-Fi without any problems.



(Signal strength: 51 % or more): The problem such as the printer cannot print may occur according to the network status. We recommends placing the printer near the wireless router.



(Signal strength: 50 % or less): The problem such as the printer cannot print may occur.
Place the printer near the wireless router.



Wi-Fi is enabled but the printer is not connected to the wireless router.



Wired LAN is enabled.



Wireless Direct is enabled.



Wi-Fi and Wired LAN are disabled.

C: Internal Light button

Tap this button to change the internal light setting.

The displayed icon changes depending on the current setting.

In all cases, the internal light is turned off during printing of patterns for image quality adjustment, and some other operations.



(Auto): Automatically turns on when the top cover is opened or during printing.



(ON): Always on.



(OFF): Always off.

D: Stop button

Cancels print jobs in progress and ends the ink drying period.

E: Ink Display Area

Displays the ink status. Select this item to view the remaining amount of ink and how to replace the ink tanks.

F: Paper Setting Display Area

Displays the media information for each feeding location. Select this item to configure the size and type of the paper loaded.

G: Other Menu Items

Displays the items used to perform maintenance and configure the various settings.

➔ [Setting Items on Operation Panel](#)

▶▶▶ Note

- By default, menu settings apply to all print jobs. However, for settings that are also available in the printer driver, the values specified in the printer driver take priority.

Basic Touch Screen Operations

You can select various functions and settings by gently touching and swiping the touch screen with your fingertip.

►► Important

- Take the following precautions when operating the touch screen. Otherwise, the touch screen may malfunction or become damaged.
 - Do not forcibly press the touch screen with your finger.
 - Do not press the touch screen with an object other than your finger (such as a ballpoint pen, pencil, fingernail, or other object with a sharp tip).
 - Do not operate the touch screen with wet or dirty hands.
 - Do not place objects on top of the touch screen.
- Do not place a protective film over the touch screen. Removing it can damage the touch screen.

Tap

Gently touch with your fingertip and then release.

Use this when selecting an item on the screen.

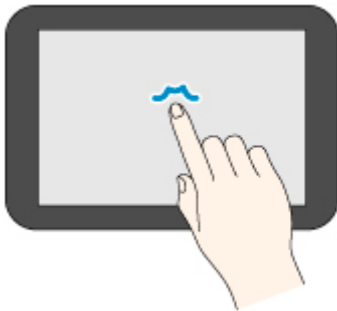

Touch

Gently touch with your fingertip.

To go (or return) to a menu or list, touch the directional mark.

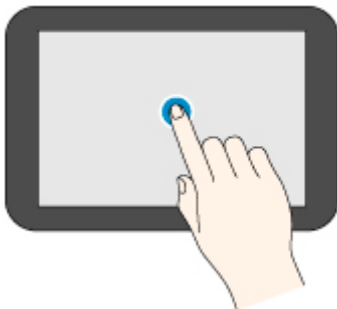

Flick

Drag and release your finger up, down, left, or right.

Use this to quickly scroll through a menu or list.

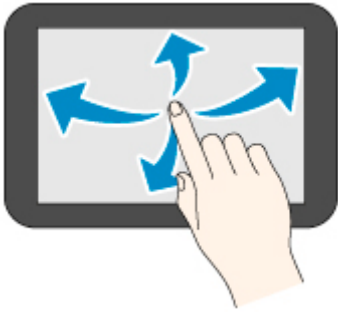

Drag

Move your finger up, down, left, or right while gently keeping it in contact with the touch screen.

Use this to move a menu or list while viewing it.

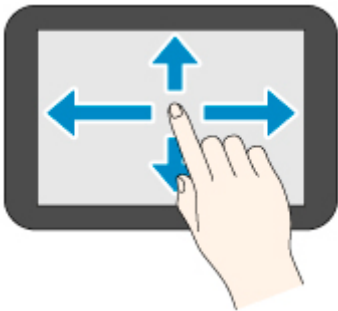

Notification Messages

When the ink is low or there is another notification, **New notice** appears in the printer information display area. Select this to display the **Notice list** screen to view messages. Select a message to display the message details screen to view the details and take action.

Icons on Touch Screen

While operating on the touch screen, some icons are displayed on the touch screen.



(HOME)

The HOME screen appears.



(Back)

Displays the screen before the current screen.

Stop

Cancels print jobs in progress and ends the ink drying period.

Menu Structure

The * on the right side of an item indicates the default value.

Values may vary depending on your model, firmware version, and printer settings.

- **Ink information**

This menu is displayed by selecting **Ink** icon.

Current estimated ink levels
Replace
Order ink now

- **Paper settings**

This menu is displayed by selecting paper information area.

Roll paper 1	
	Replace paper
	Feed/cut
	Remove paper
	Paper settings
	Width
	Length
	Type
	Advanced
Buy paper	
Roll paper 2	
	Replace paper
	Feed/cut
	Remove paper
	Roll unit use settings
	Paper settings
	Width
	Length
	Type
Advanced	
Buy paper	
Take-up mode	
	Roll unit use settings

Auto feed to take-up position	
Skip errors during take-up	
	ON / OFF
Wind up after cutting	
	Enable / Disable
Paper retention settings	
	Release / Retain
Use in take-up mode	
	Use / Do not use

Manual		
	Replace paper	
	Remove paper	
	Paper settings	
		Page size
		Width
		Length
		Type
	Advanced	
	Buy paper	



• **Maintenance**

Troubleshooting		
Nozzle Check		
Print Head Cleaning		
	Cleaning	
		All colors / Pattern 1 / Pattern 2 / Pattern 3
	Deep Cleaning	
		All colors / Pattern 1 / Pattern 2 / Pattern 3
	System Cleaning	
		All colors / Pattern 1 / Pattern 2 / Pattern 3
Print Head Alignment		
	Auto (standard)	
	Auto (advanced)	
	Manual	

Paper feed adjustment	
	Set priority
	Auto / Prioritize print quality / Prioritize length accuracy
	Adjust print quality
	Auto
	Manual
	Adjust feed length
	Print alignment pattern
	Change adjustment values
	-0.70% / -0.68% / ... / 0.68% / 0.70%

Color calibration	
	Auto adjust
	Enable/disable adjustment values
	Enable* / Disable
	Adjustment information
	Calibration guide settings
	Enable / Disable*
	Reset adjustment values

Maintenance cartridge info	
	Maintenance cartridge usage
	Replace

Head Replacement	
	Start head replacement.

Replace cutter blade unit	
----------------------------------	--

Platen cleaning	
------------------------	--

Prepare to move	
	Move indoors on the same floor
	Move indoors to a different floor
	Transport outdoors



• **Job management**

Print job	
	List of print jobs

Saved job		
	Job box list	
		Job list
	Print the job list	

Job history		
	Display job history	
	Print job history	

Pause printing		
	Enable / Disable*	

Delete all print jobs		
------------------------------	--	--



- Print from USB flash drive**

Folder/file list	
	Number of copies
	Preview
	Print settings
	The lower items of this menu are the same as the lower items of Print from USB flash settings .



- LAN settings**

Wi-Fi	
	Connection
	Network name (SSID)
	Frequency
	Wi-Fi security
	Signal strength (%)
	IPv4 address
	IPv4 subnet mask
	IPv4 default gateway
	IPv4 DNS dynamic settings
	IPv4 DNS host name
	IPv4 DNS domain name
	IPv6 link-local address
	IPv6 manual address
	IPv6 manual prefix length

IPv6 stateless address 1	
IPv6 stateless prefix length 1	
IPv6 stateless address 2	
IPv6 stateless prefix length 2	
IPv6 stateless address 3	
IPv6 stateless prefix length 3	
IPv6 stateless address 4	
IPv6 stateless prefix length 4	
DHCPv6	
DHCPv6 stateful address	
DHCPv6 stateful prefix length	
IPv6 default gateway 1	
IPv6 default gateway 2	
IPv6 default gateway 3	
IPv6 default gateway 4	
IPv6 primary DNS server address	
IPv6 secondary DNS server add.	
IPv6 DNS dyn. update: manual	
IPv6 DNS dyn. update: stateless	
IPv6 DNS dyn. update: stateful	
IPv6 Use IPv4 host/domain name	
IPv6 DNS host name	
IPv6 DNS domain name	
MAC address	
Printer name	
Bonjour service name	
Settings	
	Enable/disable Wi-Fi
	Enable / Disable
	Wi-Fi setup
	Easy wireless connect
	Manual connect
	WPS (Push button method)
	Other connection types
	WPS (PIN code method)
	Advanced

Wireless Direct	
Connection	
Network name (SSID)	
Password	
Frequency	
Wi-Fi security	
No. of printers connected now	
IPv4 address	
IPv4 subnet mask	
IPv4 default gateway	
IPv6 link-local address	
MAC address	
Printer name	
Bonjour service name	
Settings	
	Enable/disable Wireless Direct
	Yes / No
	Change network name (SSID)
	Auto update / OK
	Change password
	Change manually / Auto update
	Connection request confirmation
	ON* / OFF
Advanced	
Wired LAN	
Connection	
IPv4 address	
IPv4 subnet mask	
IPv4 default gateway	
IPv4 DNS dynamic settings	
IPv4 DNS host name	
IPv4 DNS domain name	
IPv6 link-local address	
IPv6 manual address	
IPv6 manual prefix length	
IPv6 stateless address 1	

IPv6 stateless prefix length 1				
IPv6 stateless address 2				
IPv6 stateless prefix length 2				
IPv6 stateless address 3				
IPv6 stateless prefix length 3				
IPv6 stateless address 4				
IPv6 stateless prefix length 4				
DHCPv6				
DHCPv6 stateful address				
DHCPv6 stateful prefix length				
IPv6 default gateway 1				
IPv6 default gateway 2				
IPv6 default gateway 3				
IPv6 default gateway 4				
IPv6 primary DNS server address				
IPv6 secondary DNS server add.				
IPv6 DNS dyn. update: manual				
IPv6 DNS dyn. update: stateless				
IPv6 DNS dyn. update: stateful				
IPv6 Use IPv4 host/domain name				
IPv6 DNS host name				
IPv6 DNS domain name				
MAC address				
Printer name				
Bonjour service name				
Settings				
<table border="1"><tr><td></td><td>Enable/disable Wired LAN</td></tr><tr><td></td><td>Enable / Disable</td></tr></table>		Enable/disable Wired LAN		Enable / Disable
	Enable/disable Wired LAN			
	Enable / Disable			
Advanced				

Print details



• **Printer settings**

Test print

Nozzle Check

Status print

Status print (administrator)
Print LAN details
Print the print settings
Print advanced paper settings
Print job history
Print menu map

Print settings

Print head movable width setting	
	Data width* / Maximum movable width / Paper width
Prioritize paper size	
	Enable / Disable*
Magnification level for borderless	
	Large / Medium* / Small / Minimum
PDF print settings	
Print quality settings	
	Color mode
	Color (perceptual) / Color (saturation)* / Color (correct off) / Monochrome
	Print quality
	5 (Standard) / 4 / 3* / 2 / 1 (Highest)
	Input resolution
	600 dpi / 300 dpi*
Paper settings	
	Paper src
	Auto select* / Roll paper (auto) / Roll paper 1 / Roll paper 2 / Manual
	Margin
	3mm* / 5mm
	Border
	Borderless / Bordered*
	Oversize
	Enable / Disable*
	Save paper
	ON / OFF*
	Rotate
	0 degrees* / 90 degrees

Auto rotation	
	ON / OFF*
Enlarge/Reduce	
	Fit paper size* / Same size / Scaling
Print centered	
	ON / OFF*
Cut to standard size	
	ON / OFF*
Line & pen manager	
Width correction	
	Black/gray
	Color
Processing options	
Warning display	
	Enable / Disable*
JPEG print settings	
Print quality settings	
Color mode	
	Color (perceptual) / Color (saturation)* / Color (correct off) / Monochrome
Print quality	
	5 (Standard) / 4 / 3* / 2 / 1 (Highest)
Input resolution	
	600 dpi / 300 dpi* / Specify print job
Paper settings	
Paper src	
	Auto select* / Roll paper (auto) / Roll paper 1 / Roll paper 2 / Manual
Margin	
	3mm* / 5mm
Border	
	Borderless / Bordered*
Rotate	
	0 degrees* / 90 degrees
Auto rotation	
	ON / OFF*

Enlarge/Reduce	
	Fit paper size* / Same size / Scaling
Print centered	
	ON / OFF*
Cut to standard size	
	ON / OFF*
Print from USB flash settings	
Print quality settings	
Color mode	
	Color (perceptual) / Color (saturation)* / Color (correct off) / Monochrome
Print quality	
	5 (Standard) / 4 / 3* / 2 / 1 (Highest)
Paper settings	
Paper src	
	Auto select* / Roll paper (auto) / Roll paper 1 / Roll paper 2 / Manual
Margin	
	3mm* / 5mm
Border	
	Borderless / Bordered*
Rotate	
	0 degrees* / 90 degrees
Auto rotation	
	ON / OFF*
Enlarge/Reduce	
	Fit paper size* / Same size / Scaling
Print centered	
	ON / OFF*
Cut to standard size	
	ON / OFF*
AirPrint print settings	
Print quality settings	
Color mode	
	Color (perceptual) / Color (saturation)* / Color (correct off) / ICC profile (perceptual) / ICC profile (saturation) / ICC profile (relative) / ICC profile (absolute) / Monochrome

Print resolution	
	Standard* / Speed priority / Print priority
Paper settings	
No Top/Btm Space (Save Paper)	
	ON / OFF*
Unidirectional printing	
	Enable / Disable*
Direct print settings from FTP	
Print settings 1	
Print quality settings	
Color mode	
	Color (perceptual) / Color (saturation)* / Color (correct off) / Monochrome
Print quality	
	5 (Standard) / 4 / 3* / 2 / 1 (Highest)
Input resolution	
	600 dpi / 300 dpi* / Specify print job
Paper settings	
Paper src	
	Auto select* / Roll paper (auto) / Roll paper 1 / Roll paper 2 / Manual
Margin	
	3mm* / 5mm
Border	
	Borderless / Bordered*
Oversize	
	Enable* / Disable
Save paper	
	ON / OFF*
Rotate	
	0 degrees* / 90 degrees
Auto rotation	
	ON / OFF*
Enlarge/Reduce	

		Fit paper size* / Same size / Scaling
	Print centered	
		ON / OFF*
	Cut to standard size	
		ON / OFF*
Line & pen manager		
	Width correction	
		Black/gray
		Color
Processing options		
	Warning display	
		Enable / Disable*
Print settings 2		
	Print quality settings	
	Color mode	
		Color (perceptual) / Color (saturation)* / Color (correct off) / Monochrome
	Print quality	
		5 (Standard) / 4 / 3* / 2 / 1 (Highest)
	Input resolution	
		600 dpi / 300 dpi* / Specify print job
	Paper settings	
	Paper src	
		Auto select* / Roll paper (auto) / Roll paper 1 / Roll paper 2 / Manual
	Margin	
		3mm* / 5mm
	Border	
		Borderless / Bordered*
	Oversize	
		Enable* / Disable
	Save paper	
		ON / OFF*

Rotate	
	0 degrees* / 90 degrees
Auto rotation	
	ON / OFF*
Enlarge/Reduce	
	Fit paper size* / Same size / Scaling
Print centered	
	ON / OFF*
Cut to standard size	
	ON / OFF*
Line & pen manager	
Width correction	
	Black/gray
	Color
Processing options	
Warning display	
	Enable / Disable*
Print settings 3	
Print quality settings	
Color mode	
	Color (perceptual) / Color (saturation)* / Color (correct off) / Monochrome
Print quality	
	5 (Standard) / 4 / 3* / 2 / 1 (Highest)
Input resolution	
	600 dpi / 300 dpi* / Specify print job
Paper settings	
Paper src	
	Auto select* / Roll paper (auto) / Roll paper 1 / Roll paper 2 / Manual
Margin	
	3mm* / 5mm
Border	

		Borderless / Bordered*
Oversize		
		Enable* / Disable
Save paper		
		ON / OFF*
Rotate		
		0 degrees* / 90 degrees
Auto rotation		
		ON / OFF*
Enlarge/Reduce		
		Fit paper size* / Same size / Scaling
Print centered		
		ON / OFF*
Cut to standard size		
		ON / OFF*
Line & pen manager		
	Width correction	
		Black/gray
		Color
Processing options		
	Warning display	
		Enable / Disable*
Print settings 4		
Print quality settings		
	Color mode	
		Color (perceptual) / Color (saturation)* / Color (correct off) / Monochrome
	Print quality	
		5 (Standard) / 4 / 3* / 2 / 1 (Highest)
	Input resolution	
		600 dpi / 300 dpi / Specify print job*
Paper settings		
	Paper src	

			Auto select* / Roll paper (auto) / Roll paper 1 / Roll paper 2 / Manual
		Margin	
			3mm* / 5mm
		Border	
			Borderless / Bordered*
		Oversize	
			Enable* / Disable
		Save paper	
			ON / OFF*
		Rotate	
			0 degrees* / 90 degrees
		Auto rotation	
			ON / OFF*
		Enlarge/Reduce	
			Fit paper size* / Same size / Scaling
		Print centered	
			ON / OFF*
		Cut to standard size	
			ON / OFF*
		Line & pen manager	
		Width correction	
			Black/gray
			Color
		Processing options	
		Warning display	
			Enable / Disable*
Default print settings			
	Print quality settings		
	Color mode		
		Color (perceptual) / Color (saturation)* / Color (correct off) / Monochrome	
	Print quality		
		5 (Standard) / 4 / 3* / 2 / 1 (Highest)	
Print the print settings			

LAN settings

The lower items of this menu are the same as the lower items of [LAN settings](#).

Web service setup

Web service usage registration / Web service usage cancellation	
Issue registration code	
DNS server setup	
	Auto setup* / Manual setup
Proxy server setup	
	Use / Do not use*

Web service inquiry

	Print from Canon server
--	-------------------------

Paper-related settings

Roll paper auto feed	
	Enable* / Disable
Media type selection method	
	Manual / Auto detect / Auto with confirmation* / Use current media type
Manage remaining roll amount	
	Barcodes / Auto estimate* / Disable
Roll amount warning settings	
	11m/36ft. / 9m/30ft. / 7m/23ft. / 5m/16ft.* / 3m/10ft. / 1m/3ft.
Switch roll paper when low	
	Enable / Disable*
Roll paper auto switching	
	Identify size* / Do not identify size
Detect paper setting mismatch	
	Pause / Display warning* / Do not detect / Hold job
Paper retention settings	
	Release / While feeding*
Paper size recognition settings	
Cut sheet setting 1	
	A3+* / 13"x19" (Super B)
Cut sheet setting 2	
	ISO B1* / 28"x40" (ANSI F)
Roll paper setting 1	
	10 in Roll* / B4 Roll

Roll paper setting 2	
	A3 Roll* / 300mm Roll
Roll paper setting 3	
	300mm Roll / 12 in Roll*
Roll paper setting 4	
	500mm Roll* / 20 in Roll
Roll paper setting 5	
	20 in Roll / B2 Roll*
Roll paper setting 6	
	A1 Roll* / 600mm Roll
Roll paper setting 7	
	600mm Roll / 24 in Roll*
Adjust roll unit	
Keep margin at cut sheet end	
	Enable / Disable*
Advanced paper settings	
Print advanced paper settings	
Add priority roll paper width	
	Setting 1
	Setting 2
	Setting 3
Reset all detection priority data	
Reset paper settings for all paper	
Auto maintenance settings	
Auto nozzle check	
	Standard* / 1 page / 10 pages / Disable
Nozzle check error display	
	Enable / Disable*
System Cleaning frequency	
	Standard* / Short
Print pattern after new head	
	ON* / OFF
Ink ejection status check	
	Auto fix* / Display warning / OFF
Hard disk settings	

Output method	
	Print* / Print (auto delete) / Save to job box
Save first and print	
	ON / OFF*
Common job box settings	
	Print* / Print (auto delete)
File deletion settings	
	Fast* / Fast secure / Secure / Secure (VSITR)
Data deletion	
	Fast
	Fast secure
	Secure
	Secure (VSITR)

Monitoring service settings	
Enable/disable monitoring service	
	Enable / Disable*
Communication test	
Communication log	
Timing for ink level notification	
	All colors
	0% / 10% / 20% / 30% / 40% / 50% / 60% / 70% / 80% / 90% / 100%
	GY
	0%* / 10% / 20% / 30% / 40% / 50% / 60% / 70% / 80% / 90% / 100%
	PBK
	0%* / 10% / 20% / 30% / 40% / 50% / 60% / 70% / 80% / 90% / 100%
	O
	0%* / 10% / 20% / 30% / 40% / 50% / 60% / 70% / 80% / 90% / 100%
	MBK
	0%* / 10% / 20% / 30% / 40% / 50% / 60% / 70% / 80% / 90% / 100%
	Y
	0%* / 10% / 20% / 30% / 40% / 50% / 60% / 70% / 80% / 90% / 100%
	M
	0%* / 10% / 20% / 30% / 40% / 50% / 60% / 70% / 80% / 90% / 100%
	C
	0%* / 10% / 20% / 30% / 40% / 50% / 60% / 70% / 80% / 90% / 100%
Check settings	

Warning notification settings	
	Enable* / Disable

Other printer settings

Energy saving settings	
Auto power off	
	5 minutes / 10 min. / 30 min. / 1 hour / 4 hours / 8 hours / 12 hours / OFF
Sleep timer	
	5 minutes* / 10 min. / 15 min. / 20 min. / 30 min. / 40 min. / 50 min. / 60 min.
Use USB connection	
	Use* / Do not use
Date/time settings	
Date display format	
	YYYY/MM/DD / MM/DD/YYYY / DD/MM/YYYY
Time zone (GMT)	
	0 / +1 / ... / +12 / -12 / ... / -1
Length unit settings	
	Meters / Feet/inches
Buzzer settings	
	Enable* / Disable
EOP timer settings	
	1 minute / 2 minutes / 5 minutes / 10 minutes* / 30 minutes / 60 minutes
Job history sending settings	
	Send / Do not send*
Menu row height	
	Wide* / Standard

Language selection

Firmware update

Install update	
Check current version	
Update notification settings	
	Yes* / No
Show notifications (tool update)	
	ON* / OFF
DNS server setup	
	Auto setup* / Manual setup

Proxy server setup	
	Use / Do not use*

Security settings

Administrator password settings	
	Remote UI and other tools / LCD, Remote UI, and other tools
Operation restrictions	
	Job history
	Restrict / Do not restrict*
	Remote UI
	Restrict / Do not restrict*
	Print from USB flash drive
	Restrict / Do not restrict*
IEEE802.1X/EAP settings	
	Enable/disable
	Enable / Disable*
	Search for EAP router
	Last authentication result
	Authentication
	TLS* / TTLS / PEAP
	Advanced setup
	User-ID
	Username
	Password
	Authentication server name
	Verify auth. server name
	Enable* / Disable
	Verify auth. server certificates
Enable* / Disable	

Import/export settings

	Import
	Export

Initialize printer settings



• **Printer information**

System information	
Hard disk information	
Error history	
	Hardware error
	Recoverable error
	Paper feed/transfer error
Usage	
	Total print area
	Duty counter
Head information	
Head alignment performance log	
Values applied with auto settings	
	Paper thickness (head height)
	Transport unit vacuum strength

Advanced (Paper settings)

Select the paper setting display area and select **Paper settings** to display this menu.

Advanced	
	Roll length (change default)
	Head height
	Auto / High / Medium-high / Standard / Medium-low / Low / Super low
	Skew detection accuracy
	Standard / Loose / OFF
	Cutting mode
	Automatic cut / Eject cut / User cut
	Cut speed
	Fast / Standard / Slow
	Trim edge first
	Auto / Off / On(Preset Length) / On(Input Length) / Manual
	Cut-dust reduction
	ON / OFF
	Transport unit vacuum strength
	Auto / Strong / Medium-strong / Standard / Medium-weak / Weak
	Guide arm retention pressure
	High / Low
	Roll paper tension (printing)
	High / Standard / Low
	Roll paper tension (feeding)
	High / Standard / Low
	Roll paper tension (winding up)
	High / Standard / Low
	Pause between scans
	Ink drying wait time
	OFF / 0.5 seconds / 1 second / 3 seconds / 5 seconds / 7 seconds / 9 seconds
	Ink drying target area
	Overall / Leading edge
	Pause between pages
	OFF / 30 seconds / 1 minute / 3 minutes / 5 minutes / 10 minutes / 30 minutes / 60 minutes
	Pause on last page take-up

	OFF / 5 minutes / 10 minutes / 30 minutes / 60 minutes / 120 minutes / 240 minutes / 480 minutes / 960 minutes	
Pause timing priority		
	Between pages / On last page	
Leading edge margin (roll)		
	3mm / 20mm	
Leading edge margin (sheet)		
	3mm / 20mm	
Extension for borderless printing		
	Paper with recommended width	
		Large / Standard / Small
	Paper of sufficient width	
		Select extension amount
		1 (min) / 2 / 3 / 4 / 5 / 6 / 7 / 8 (max)
	Sample of extension amounts	
Detect paper width		
	Enable / Disable	
Paper core outer diameter		
Paper thickness		
Auto-rewind roll paper at sleep		
	Enable / Disable	
Reset detection priority data		
Reset paper settings by paper		

Advanced (LAN settings)



To display this item, select **LAN settings** on the HOME screen, and then select **Wi-Fi / Wireless Direct / Wired LAN > Settings > Advanced**.

The * on the right side of an item indicates the default value.

Advanced	
Set printer name	
TCP/IP settings	
IPv4	
	IP address
	Auto setup* / Manual setup
DNS server	
	DNS server setup
	Auto setup* / Manual setup
	Dynamic update settings
	Enable / Disable*
	Host name
	Domain name
Proxy server	
	Use / Do not use*
DHCP option settings	
	Acquire host name
	Enable / Disable*
	DNS dynamic update
	Enable / Disable*
	Acquire domain name
	Enable / Disable*
IPv6	
	Enable/disable IPv6
	Enable* / Disable
IPsec settings	
	Enable / Disable*
Use DHCPv6	
	Use* / Do not use
Manual address	

		Use / Do not use*
DNS server		
	DNS server setup	
		Auto setup* / Manual setup
	Dynamic update settings	
	IPv6 DNS dyn. update: manual	
		Enable / Disable*
	IPv6 DNS dyn. update: stateless	
		Enable / Disable*
	IPv6 DNS dyn. update: stateful	
		Enable / Disable*
	IPv6 Use IPv4 host/domain name	
		Enable / Disable*
	IPv6 DNS host name	
	IPv6 DNS domain name	
	DHCP option settings	
	DNS dynamic update	
		Enable / Disable*
	Acquire domain name	
		Enable / Disable*
WSD settings		
	Enable/disable WSD	
		Enable / Disable*
	Optimize inbound WSD	
		Enable* / Disable
	Timeout settings	
		20 minutes / 15 minutes* / 10 minutes / 5 minutes / 1 minute
Bonjour settings		
	Enable/disable Bonjour	
		Enable* / Disable
	Service name	
SNTP settings		
	Client operation status	
		Enable / Disable*
	NTP server address	
	Polling interval	

Spanning tree settings	
	Enable / Disable*
LPR protocol settings	
	Enable* / Disable
RAW protocol	
	ON* / OFF
LLMNR	
	ON* / OFF
Gigabit Ethernet settings	
	Autonegotiation* / 10 Mbps half duplex / 10 Mbps full duplex / 100 Mbps half duplex / 100 Mbps full duplex / 1 Gbps full duplex
Use Dedicated Port	
	ON* / OFF
IPP settings	
	Enable/disable IPP
	Enable* / Disable
	Security Print
	Enable* / Disable
Wi-Fi DRX settings	
	Enable* / Disable
Wired LAN DRX settings	
	Enable* / Disable
Reset SSL certificates	
Reset LAN settings	

Setting Items on Operation Panel

▶▶▶ Note

- The administrator password is required to change some setting items if it is enabled for changing settings using the operation panel.

For more on setting items which the administrator password is required:

➔ [Setting Administrator Password on Operation Panel](#)

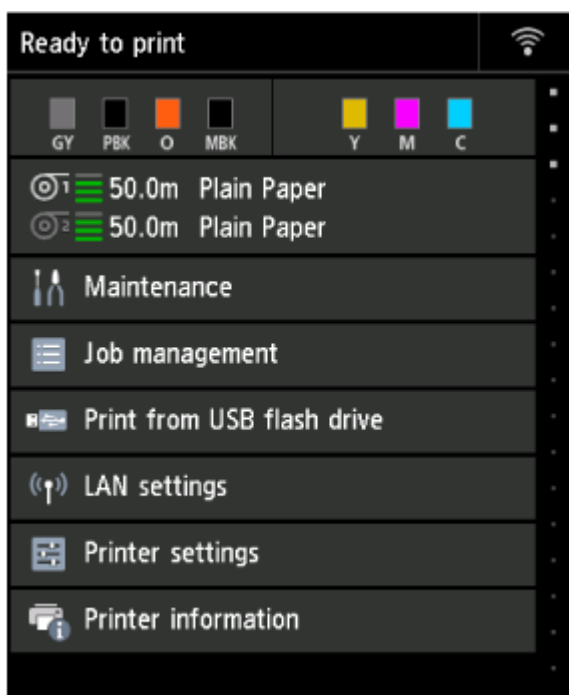

[Maintenance](#)



[Job management](#)



Print from USB flash drive

➔ [Printing Data Saved on USB Flash Drive](#)



LAN settings



Printer settings

- [Test print](#)
- [Print settings](#)
- [LAN settings](#)
- [Web service setup](#)
- [Paper-related settings](#)
- [Auto maintenance settings](#)
- [Hard disk settings](#)
- [Monitoring service settings](#)
- [Other printer settings](#)
- [Language selection](#)
- [Firmware update](#)
- [Security settings](#)
- **Import/export settings**
 - ➔ [Migrating Printer's Setting](#)
- **Initialize printer settings**
 - ➔ [Initializing Printer's Setting](#)



Printer information

Maintenance

This item is displayed on the HOME screen.

- **Nozzle Check**

Prints out the nozzle check pattern.

➡ [Checking for Nozzle Clogging](#)

- **Print Head Cleaning**

Select this to clean the print head.

➡ [Cleaning the Print Head](#)

- **Print Head Alignment**

Adjusts the alignment of print head.

➡ [Automatic Adjustment to Straighten Lines and Align Colors](#)

➡ [Manual Adjustment to Straighten Lines and Align Colors](#)

- **Paper feed adjustment**

Sets the paper feed amount.

- **Set priority**

Sets the method of adjusting the paper feed amount.

- **Auto**

Prioritize print quality will be selected when **Print Target** is set from the printer driver.

- **Prioritize print quality**

Adjusts the print quality to make the horizontal streaks of the print less noticeable. The setting for **Adjust print quality** is applied. When **Paper feed fine adjustment** is executed, the setting for **Paper feed fine adjustment** is applied in addition to the setting for **Adjust print quality**.

- **Prioritize length accuracy**

Adjusts the length of the ruled lines on the printed piece to match. The values for **Change adjustment values** under **Adjust feed length** are applied.

- **Adjust print quality**

Select this when the printed material has different colored horizontal streaks.

➡ [Automatically Adjusting Different Colored Horizontal Streaks](#)

➡ [Manually Adjusting Different Colored Horizontal Streaks](#)

- **Adjust feed length**

Select this to print the exact length of the ruled lines in a CAD drawing.

➡ [Adjusting Line Length](#)

- **Color calibration**

Select this to perform the color calibration or check the adjustment information.

➡ [Performing Color Calibration](#)

- **Maintenance cartridge info**

Displays the estimated usage of maintenance cartridge. Select **Replace** to replace the maintenance cartridge.

➡ [Replacing the Maintenance Cartridge](#)

- **Head Replacement**

Select this to replace the print head.

➡ [Replacing the Print Head](#)

- **Replace cutter blade unit**

Select this to replace the cutter blade.

➡ [Replacing the Cutter Blade](#)

- **Platen cleaning**

Select this to clean inside the top cover.

➡ [Cleaning Inside the Top Cover](#)

- **Prepare to move**

Select this to prepare for transporting the printer.

➡ [Preparing to Transfer the Printer](#)

Job management

This item is displayed on the HOME screen.

- **Print job**

Displays the print job list. Selecting a job displays the details. You can also delete or prioritize jobs on this menu.

- **Saved job**

Displays the saved print job list. You can print / delete saved jobs and print job list on each job box.

▶▶▶ Note

- Enter the password if it is enabled for a personal job box using Remote UI.

- **Job history**

▶▶▶ Important

- The administrator password is required to display the job history if it is enabled for changing settings using the operation panel.

- **Display job history**

Displays the print job history. Selecting a job displays the details.

- **Print job history**

Prints out the print job history.

- **Pause printing**

Selecting **Enable** while a print job is in progress pauses the print job after the current job is completed.

- **Delete all print jobs**

Deletes all jobs in the job queue.

LAN settings

This item is displayed on the HOME screen.

Important

- The administrator password is required to change settings if it is enabled for changing settings using the operation panel.

Note

- You can also display LAN settings by selecting  (**Network**) on the HOME screen.

Wi-Fi

The following setting information on the Wi-Fi connection is displayed. (Some items are not displayed depending on printer settings.)

Items	Setting
Connection	Enabled (connected) / Enabled (disconnected) / Disable
Network name (SSID)	XXXXXXXXXXXXXXXXXX XXXXXXXXXXXXXXXXXX
Frequency	2.4 GHz
Wi-Fi security	Disable / WPA-PSK (TKIP) / WPA-PSK (AES) / WPA2-PSK (TKIP) / WPA2-PSK (AES) / WPA3-SAE (AES) / WPA-EAP (AES)* / WPA2-EAP (AES)* / WPA3-EAP (AES)* *Supports IEEE802.1X (EAP-TLS / EAP-TTLS / PEAP)
Signal strength (%)	XXX
IPv4 address	XXX. XXX. XXX. XXX
IPv4 subnet mask	XXX. XXX. XXX. XXX
IPv4 default gateway	XXX. XXX. XXX. XXX
IPv4 DNS dynamic settings	Enable / Disable
IPv4 DNS host name	XXXXXXXXXXXX
IPv4 DNS domain name	XXXXXXXXXXXX
IPv6 link-local address	XXXX: XXXX: XXXX: XXXX: XXXX: XXXX: XXXX: XXXX
IPv6 manual address	XXXX: XXXX: XXXX: XXXX: XXXX: XXXX: XXXX: XXXX
IPv6 manual prefix length	XXX
IPv6 stateless address 1	XXXX: XXXX: XXXX: XXXX: XXXX: XXXX: XXXX: XXXX
IPv6 stateless prefix length 1	XXX

IPv6 stateless address 2	XXXX: XXXX: XXXX: XXXX: XXXX: XXXX: XXXX: XXXX
IPv6 stateless prefix length 2	XXX
IPv6 stateless address 3	XXXX: XXXX: XXXX: XXXX: XXXX: XXXX: XXXX: XXXX
IPv6 stateless prefix length 3	XXX
IPv6 stateless address 4	XXXX: XXXX: XXXX: XXXX: XXXX: XXXX: XXXX: XXXX
IPv6 stateless prefix length 4	XXX
DHCPv6	Enable / Disable
DHCPv6 stateful address	XXXX: XXXX: XXXX: XXXX: XXXX: XXXX: XXXX: XXXX
DHCPv6 stateful prefix length	XXX
IPv6 default gateway 1	XXXX: XXXX: XXXX: XXXX: XXXX: XXXX: XXXX: XXXX
IPv6 default gateway 2	XXXX: XXXX: XXXX: XXXX: XXXX: XXXX: XXXX: XXXX
IPv6 default gateway 3	XXXX: XXXX: XXXX: XXXX: XXXX: XXXX: XXXX: XXXX
IPv6 default gateway 4	XXXX: XXXX: XXXX: XXXX: XXXX: XXXX: XXXX: XXXX
IPv6 primary DNS server address	XXXX: XXXX: XXXX: XXXX: XXXX: XXXX: XXXX: XXXX
IPv6 secondary DNS server add.	XXXX: XXXX: XXXX: XXXX: XXXX: XXXX: XXXX: XXXX
IPv6 DNS dyn. update: manual	Enable / Disable
IPv6 DNS dyn. update: stateless	Enable / Disable
IPv6 DNS dyn. update: stateful	Enable / Disable
IPv6 Use IPv4 host/domain name	Enable / Disable
IPv6 DNS host name	XXXXXXXXXXXXXX
IPv6 DNS domain name	XXXXXXXXXXXXXX
MAC address	XX:XX:XX:XX:XX:XX
Printer name	XXXXXXXXXXXXXXXXXX
Bonjour service name	XXXXXXXXXXXXXX XXXXXXXXXXXXXX XXXXXXXXXXXXXX XXXXXXXXXXXXXX

("XX" represents alphanumeric characters.)

To change the setting, select **Settings**.

- **Enable/disable Wi-Fi**

Select **Enable** to wirelessly connect via wireless router.

- **Wi-Fi setup**

Select how to setup Wi-Fi.

- **Easy wireless connect**

Select if you specify the settings of the access point information to the printer directly from a device (e.g. smartphone, or tablet) without operating the wireless router. Follow the on-screen instructions of the connecting device for the setup procedure.

- **Manual connect**

Select when you perform settings for Wi-Fi manually using the operation panel of the printer.

- **WPS (Push button method)**

Select when you perform settings for Wi-Fi using a wireless router supporting a Wi-Fi Protected Setup (WPS) push button method. Follow the on-screen instructions during setup.

- **Other connection types**

- **WPS (PIN code method)**

Select when you perform settings for Wi-Fi using a wireless router supporting a Wi-Fi Protected Setup (WPS) PIN code method. Follow the on-screen instructions during setup.

▶▶▶ Note

- Select **Advanced** to make detailed LAN settings.

For the items that can be set, see the following.

➡ [Advanced](#)

- **Wireless Direct**

The following setting information on the Wireless Direct connection is displayed. (Some items are not displayed depending on printer settings.)

Items	Setting
Connection	Enable / Disable
Network name (SSID)	DIRECT-XXXX-GP-NNNN*1
Password	XXXXXXXXXX
Frequency	2.4 GHz
Wi-Fi security	WPA2-PSK (AES)
No. of printers connected now	XX/XX
IPv4 address	XXX. XXX. XXX. XXX
IPv4 subnet mask	XXX. XXX. XXX. XXX
IPv4 default gateway	XXX. XXX. XXX. XXX
IPv6 link-local address	XXXX: XXXX: XXXX: XXXX: XXXX: XXXX: XXXX: XXXX
MAC address	XX:XX:XX:XX:XX:XX

Printer name	XXXXXXXXXXXXXXXXXX
Bonjour service name	XXXXXXXXXXXXXXXXXX XXXXXXXXXXXXXXXXXX XXXXXXXXXXXXXXXXXX XXXXXXXXXXXXXXXXXX

*1 "GP-NNNN" represents the name of your model.

("XX" represents alphanumeric characters.)

To change the setting, select **Settings**.

- **Enable/disable Wireless Direct**

Select **Enable** to wirelessly connect without wireless router.

- **Change network name (SSID)**

Changes the identifier (SSID/the printer's name displayed on a Wi-Fi Direct compatible device) for Wireless Direct.

- **Change password**

Changes the password for Wireless Direct.

- **Connection request confirmation**

Changes the display / non-display of the confirmation screen when Wi-Fi Direct compatible devices are connected to the printer.

▶▶▶ Note

- By selecting **Advanced**, you can set LAN in detail.

For the items that can be set, see the following.

➡ [Advanced](#)

- **Wired LAN**

The following setting information on the Wired LAN connection is displayed. (Some items are not displayed depending on printer settings.)

Items	Setting
Connection	Enabled (connected) / Enabled (disconnected) / Disable
IPv4 address	XXX. XXX. XXX. XXX
IPv4 subnet mask	XXX. XXX. XXX. XXX
IPv4 default gateway	XXX. XXX. XXX. XXX
IPv4 DNS dynamic settings	Enable / Disable
IPv4 DNS host name	XXXXXXXXXXXXXXXXXX
IPv4 DNS domain name	XXXXXXXXXXXXXXXXXX
IPv6 link-local address	XXXX: XXXX: XXXX: XXXX: XXXX: XXXX: XXXX: XXXX

IPv6 manual address	XXXX: XXXX: XXXX: XXXX: XXXX: XXXX: XXXX: XXXX
IPv6 manual prefix length	XXX
IPv6 stateless address 1	XXXX: XXXX: XXXX: XXXX: XXXX: XXXX: XXXX: XXXX
IPv6 stateless prefix length 1	XXX
IPv6 stateless address 2	XXXX: XXXX: XXXX: XXXX: XXXX: XXXX: XXXX: XXXX
IPv6 stateless prefix length 2	XXX
IPv6 stateless address 3	XXXX: XXXX: XXXX: XXXX: XXXX: XXXX: XXXX: XXXX
IPv6 stateless prefix length 3	XXX
IPv6 stateless address 4	XXXX: XXXX: XXXX: XXXX: XXXX: XXXX: XXXX: XXXX
IPv6 stateless prefix length 4	XXX
DHCPv6	Enable / Disable
DHCPv6 stateful address	XXXX: XXXX: XXXX: XXXX: XXXX: XXXX: XXXX: XXXX
DHCPv6 stateful prefix length	XXX
IPv6 default gateway 1	XXXX: XXXX: XXXX: XXXX: XXXX: XXXX: XXXX: XXXX
IPv6 default gateway 2	XXXX: XXXX: XXXX: XXXX: XXXX: XXXX: XXXX: XXXX
IPv6 default gateway 3	XXXX: XXXX: XXXX: XXXX: XXXX: XXXX: XXXX: XXXX
IPv6 default gateway 4	XXXX: XXXX: XXXX: XXXX: XXXX: XXXX: XXXX: XXXX
IPv6 primary DNS server address	XXXX: XXXX: XXXX: XXXX: XXXX: XXXX: XXXX: XXXX
IPv6 secondary DNS server add.	XXXX: XXXX: XXXX: XXXX: XXXX: XXXX: XXXX: XXXX
IPv6 DNS dyn. update: manual	Enable / Disable
IPv6 DNS dyn. update: stateless	Enable / Disable
IPv6 DNS dyn. update: stateful	Enable / Disable
IPv6 Use IPv4 host/domain name	Enable / Disable
IPv6 DNS host name	XXXXXXXXXXXXXX
IPv6 DNS domain name	XXXXXXXXXXXXXX
MAC address	XX:XX:XX:XX:XX:XX
Printer name	XXXXXXXXXXXXXX

Bonjour service name	XXXXXXXXXXXXXX XXXXXXXXXXXXXX XXXXXXXXXXXXXX XXXXXXXXXXXXXX
-----------------------------	--

("XX" represents alphanumeric characters.)

To change the setting, select **Settings**.

- **Enable/disable Wired LAN**

Select **Enable** when connecting to wired LAN.

▶▶▶ Note

- By selecting **Advanced**, you can set LAN in detail.

For the items that can be set, see the following.

➡ [Advanced](#)

- **Print details**

Prints out the LAN setting information of the printer with Wi-Fi connection, wired LAN connection, wireless direct connection.

▶▶▶ Important

- Important information on your computer is stated on the paper on which the LAN setting information is printed. Please handle with care enough.

▶▶▶ Note

- You can also print LAN settings information by selecting **Test print > Print LAN details** after

selecting  **Printer settings** on the Home Screen.

- **Advanced**

By selecting **Advanced** on each setting screen of Wi-Fi connection, wired LAN connection, wireless direct connection, LAN information can be set in detail.

▶▶▶ Important

- If the LAN is disabled, the following items can not be selected.

- **Set printer name**

Specifies the printer name. You can use up to 15 characters for the name.

▶▶▶ Note

- You cannot use the same printer name as that already used for other LAN connected devices.
- You cannot use a hyphen for the initial or last character of the printer name.

- **TCP/IP settings**

Performs IPv4 or IPv6 setting.

- **WSD settings**

Setting items when you use WSD (one of the network protocols supported in Windows).

- **Enable/disable WSD**

Selects whether WSD is enabled or disabled.

▶▶▶ **Note**

- When this setting is enabled, the printer icon is displayed on the Network Explorer in Windows.

- **Optimize inbound WSD**

Selecting **Enable** allows you to receive the WSD printing data faster.

- **Timeout settings**

Specifies the timeout length.

- **Bonjour settings**

Setting items for LAN using Bonjour.

- **Enable/disable Bonjour**

Selecting **Enable** allows you to use Bonjour to perform the network settings.

- **Service name**

Specifies the Bonjour service name. You can use up to 48 characters for the name.

The factory default setting is "Canon XX-NNN" where XX-NNN is the model name of your printer.

▶▶▶ **Note**

- You cannot use the same service name as that already used for other LAN connected devices.

- **SNTP settings**

Performs various settings for SNTP (Simple Network Time Protocol).

- **Spanning tree settings**

Enables/Disables spanning tree. Selecting **Enable** avoids circulating data on a network.

- **LPR protocol settings**

Enables/Disables the LPR setting.

- **RAW protocol**

Enables/Disables RAW printing.

- **LLMNR**

Specifies ON/OFF of LLMNR (Link-Local Multicast Name Resolution). Selecting **ON** allows the printer to detect printer's IP address from the printer name without a DNS server.

- **Gigabit Ethernet settings**

Specifies the communication speed and communication method when using Gigabit Ethernet.

- **Use Dedicated Port**

Selects whether to use a dedicated port for a command sent from a Canon application to the printer.

Selecting **ON** allows you to use the dedicated port.

- **IPP settings**

- **Enable/disable IPP**

- Selecting **Enable** allows you to print over a network using the IPP protocol.

- **Security Print**

- Set to **Enable** to print using the security print function with the IPP protocol, for example with AirPrint.

- **Wi-Fi DRX settings**

- Selecting **Enable** allows you to activate discontinuous reception when using Wi-Fi.

- **Wired LAN DRX settings**

- Selecting **Enable** allows you to activate discontinuous reception when the printer is connected to a device compatible with wired LAN.

- **Reset SSL certificates**

- Initializes SSL certificate information.

- **Reset LAN settings**

- Initializes the network settings on the printer.

- After resetting, perform setup again as necessary.

Test print



This item is displayed when you select **Printer settings** on the Home screen.

- **Nozzle Check**

Prints out the nozzle check pattern.

➔ [Checking for Nozzle Clogging](#)

- **Status print**

Prints out the printer status and setting value information.

▶▶▶ **Note**

- **Status print (administrator)** is also displayed if the administrator password is enabled for changing settings using the operation panel.

➔ [Status Print](#)

- **Print LAN details**

Prints out the network setting information.

➔ [Printing Network Settings](#)

- **Print the print settings**

Prints out the print settings list.

- **Print advanced paper settings**

Prints out the setting values specified by **Advanced paper settings**.

- **Print job history**

Prints out a record of print jobs, including the paper type and size, amount of ink consumed, and so on. Ink consumption indicates a rough estimate of the amount of ink consumed per print job.

➔ [Job management](#)

- **Print menu map**

Prints out the menu list.

Print settings



This item is displayed when you select **Printer settings** on the Home screen.

- **Print head movable width setting**

Adjusts the print head movable width.

- **Prioritize paper size**

This is a setting item for roll paper.

Select **Enable** to use the paper size setting as the basis for printing instead of other settings. The text or images in the margin are not printed.

Select **Disable** to give priority to printing text or images.

▶▶▶ Note

- The printed paper length is longer than the actual paper length. This is because the printed paper includes the upper/lower margins specified by **Roll Paper Safety Margin** and **Near End Margin** in the printer driver and excludes the paper margins.

- **Magnification level for borderless**

Sets magnification level when performing borderless printing in the following print method.

Normally, the image is enlarged slightly and printed so that there is no border. If the border remains, change this setting.

- Printing JPEG file
- Printing using AirPrint
- Printing PDF file
- Printing data saved on the USB flash drive directly
- Printing directly from FTP

- **PDF print settings**

Performs PDF print settings.

- **JPEG print settings**

Performs JPEG print settings.

- **Print from USB flash settings**

Performs settings for printing data saved on the USB flash drive.

- **AirPrint print settings**

Performs **AirPrint print settings** when printing with AirPrint.

- **Direct print settings from FTP**

Performs print settings when printing directly from FTP. You can perform four settings individually.

- **Default print settings**

Prints out the default values of print settings.

- **Print the print settings**

Prints out the print settings list.

Web service setup



This item is displayed when you select **Printer settings** on the Home screen.

»» Important

- The administrator password is required to change settings if it is enabled for changing settings using the operation panel.

- **Web service usage registration / Web service usage cancellation**

Registers/Deletes Web service usage to use the printer device information to/from PIXMA/MAXIFY Cloud Link.

- **Issue registration code**

In order to link the web service and printer, obtain the registration code from the service origin.

- **DNS server setup**

Performs settings for a DNS server. Select **Auto setup** or **Manual setup**. If you select **Manual setup**, follow the display on the touch screen to perform settings.

- **Proxy server setup**

Performs settings for a proxy server. Follow the display on the touch screen to perform settings.

Paper-related settings



This item is displayed when you select **Printer settings** on the Home screen.

- **Roll paper auto feed**

Enables/disables feeding roll paper automatically when you load it on the roll unit.

Selecting **Enable** detects the paper edge automatically and paper is loaded automatically only by putting roll paper on the roll unit.

Select **Disable** if you load roll paper manually, or if you have any problem in feeding roll paper automatically.

▶▶▶ **Note**

- Roll paper with a width of less than 250 mm cannot be fed automatically.
Select **Disable** and feed paper manually.

- **Media type selection method**

Specifies a method to select the media type when paper is loaded.

- **Manual**

You need to select a media type from the registered media types manually.

- **Auto detect**

The media type estimated by the printer's sensor is set automatically.

As the estimation accuracy increases, it will be not necessary to select the media type each time.

- **Auto with confirmation**

Among the media types estimated by the printer's sensor, the most likely ones are listed at the top.

You need to select a media type from the listed media types manually.

- **Use current media type**

Select this to continue using the same type of paper.

▶▶▶ **Note**

- When using the paper estimation function, the paper width detection function is enabled even if you set **Detect paper width** to **Disable**.
- If the loaded paper is used by your printer for the first time, or if there is no applicable media type, **No selection log entry** will be displayed.
If **No selection log entry** is displayed, select a media type manually.
At this time, the printer learns the data of the selected media type.
The next time the same paper is loaded, the media type is estimated from this data.
- When using a paper that is not listed in the paper information list, perform **Create Custom Paper** in Media Configuration Tool. After create the paper information, we recommend to perform **Paper feed adjustment**.

- If the created custom paper does not appear as a candidate in the paper information list even if it is fed many times, perform **Paper feed adjustment** again.
- Errors may occur in the estimation results.

- **Manage remaining roll amount**

Selects the method to manage remaining roll amount and that to display warning when the roll is running short.

- **Barcodes**

Manages remaining roll amount by using a barcode.

By using the barcode every time you replace a roll, you can manage remaining roll amount properly. Specify the roll length properly when you load a new roll.

- **Auto estimate**

Estimates and manages the remaining amount of roll paper.

The estimated remaining roll amount is displayed on the HOME screen.

The barcode is not printed when **Auto estimate** is selected.

To estimate the remaining roll amount, **Paper thickness** and **Paper core outer diameter** have to be set correctly.

When using a paper that is not listed in the paper information list, set Thickness and Paper Tube Size in **Advanced paper settings** or in Media Configuration Tool.

For paper thickness and paper tube outer diameter size, contact the paper manufacturer.

▶▶▶ Important

- If you do not select the media type correctly, the remaining roll amount may not be estimated correctly.
- There is an error in the estimated remaining roll amount, and paper may run out during printing.

- **Disable**

Select to disable managing remaining roll amount.

- **Roll amount warning settings**

Specifies when to warn the remaining roll paper amount.

▶▶▶ Note

- This setting is enabled when **Barcodes** or **Auto estimate** is selected for **Manage remaining roll amount**.

- **Switch roll paper when low**

Switches the roll paper for printing automatically when the roll is running out while printing is in progress.

- **Enable**

This setting is valid only when **Barcodes** is selected for **Manage remaining roll amount**.

The roll paper for printing is switched with several rolls remaining.

- **Disable**

Switches the roll paper for printing by estimating the remaining amount based on the roll amount value you entered.

In addition, if the roll length is not specified properly, paper may remain when switching, or it may have run out while printing is in progress.

- **Roll paper auto switching**

Enables/Disables switching roll paper feed position by detecting the paper size.

- **Detect paper setting mismatch**

Selects printer action when you start printing with the paper size, the media type, and print settings different from those registered.

- **Paper retention settings**

Selects whether to contact the roll nip with the rolls in feeding paper.

- If you select **While feeding**, the roll nip contacts with the rolls and automatic feeding is enabled.
- If you select **Release**, the roll nip does not contact with the rolls.

If you select **Release**, automatic feed and automatic switching of top and bottom roll paper can not be performed.

Feed paper manually.

- **Paper size recognition settings**

Selects which size is preferred when paper size detection is enabled.

- **Cut sheet setting 1**

Select whether ISO A3+ or 13"x19"(Super B) is applied when a sheet of an intermediate size is detected.

- **Cut sheet setting 2*1**

Select whether ISO B1 or 28"x40" (ANSI F) is applied when a sheet of an intermediate size is detected.

*1: Not displayed on GP-2600S/GP-526S.

- **Roll paper setting 1**

Select whether 10 in. or B4 is applied when a roll of an intermediate size is detected.

- **Roll paper setting 2**

Select whether A3 or 300 mm is applied when a roll of an intermediate size is detected.

- **Roll paper setting 3**

Select whether 300 mm or 12 in. is applied when a roll of an intermediate size is detected.

- **Roll paper setting 4**

Select whether 500 mm or 20 in. is applied when a roll of an intermediate size is detected.

- **Roll paper setting 5**

Select whether 20 in. or B2 is applied when a roll of an intermediate size is detected.

- **Roll paper setting 6**

Select whether A1 or 600 mm is applied when a roll of an intermediate size is detected.

- **Roll paper setting 7**

Select whether 600 mm or 24 in. is applied when a roll of an intermediate size is detected.

- **Adjust roll unit**

Select this setting item when you replace the roll unit.

- **Keep margin at cut sheet end**

When printing on the sheet using AirPrint, selecting **Enable** sets the trailing edge of the paper to 20 mm. Select **Enable** if printing on the trailing edge of the paper is disturbed.

- **Advanced paper settings**

Performs advanced paper settings for each media types.

- **Print advanced paper settings**

Prints out each setting specified in **Advanced paper settings**.

- **Add priority roll paper width**

When paper size is detected, set the width of the roll paper to be recognized first. Judge in order from 1 in the list.

- **Reset all detection priority data**

Resets estimated data for all learned paper when **Auto detect** or **Auto with confirmation** is selected in **Media type selection method**.

- **Reset paper settings for all paper**

Initializes each setting specified in **Advanced paper settings**.

Entering the administrator password is required if it is enabled.

▶▶▶ Important

- The following information is deleted when paper information is reset to the factory defaults.
 - Estimated data for all learned paper when **Auto detect** or **Auto with confirmation** is selected in **Media type selection method**.
 - Media type selection log.

Auto maintenance settings



This item is displayed when you select **Printer settings** on the Home screen.

»» Important

- The administrator password is required to change settings if it is enabled for changing settings using the operation panel.

- **Auto nozzle check**

Enables/Disables automatic nozzle checking. You can also select the page interval to perform automatic nozzle checking.

- **Nozzle check error display**

Enables/Disables displaying the nozzle check error.

- **System Cleaning frequency**

Specifies the frequency of automatic system cleaning.

»» Note

- To maintain print quality, we recommend you select **Short** if you use the printer at a higher elevation.

- **Print pattern after new head**

Selects whether you print an adjustment pattern after replacing the Print head.

- **Ink ejection status check**

Sets the function to automatically detect the print head ejection status.

- **Auto fix**

Performs an automatic fix when a change in the print head ejection status is detected.

- **Display warning**

Displays a notification message on the touch screen when a change in the print head ejection status is detected.

- **OFF**

Disables automatic detection.

»» Important

- Depending on the paper feeding method, **Cutting mode** settings, etc., automatic detection may not be performed.

Hard disk settings



This item is displayed when you select **Printer settings** on the Home screen.

▶▶ Important

- The administrator password is required to change settings if it is enabled for changing settings using the operation panel.

• **Output method**

Selects the printing method for jobs received from software other than the printer driver. When using the printer driver, configure settings on the printer driver.

- **Print**

Performs printing as usual.

- **Print (auto delete)**

Deletes the data from the printer's hard disk after printing is completed.

- **Save to job box**

Only saves the print job in job box without printing it.

• **Save first and print**

A setting for jobs received from software other than the printer driver. When using the printer driver, configure settings on the printer driver. Select **ON** to print the job after it has been saved.

• **Common job box settings**

Select **Print (auto delete)** to print without saving jobs in common job box.

• **File deletion settings**

Selects the data erasing method when deleting a **Print job** or **Saved job**, or when **Print (auto delete)** is selected in **Output method** or **Common job box settings**.

- **Fast**

Erases file management data for print job data stored on the printer's hard disk. Choose this method for relatively fast erasure. Because only the file management data is erased, the print job data itself is not erased.

- **Fast secure**

Erases the data encryption key specified for the hard disk drive. Specifying the encryption key again does not allow you to read and use data saved in the past safely and fast. Select to erase highly confidential data.

- **Secure**

Overwrites the entire hard disk with 00, FF, and random data (one time each) after the data encryption key specified for the hard disk drive is erased. Verification is performed to check if the data was correctly written. Choose this method to erase especially confidential data. It is virtually

impossible to recover the overwritten data. Conforms to the DoD5220.22-M standard of the U.S. Department of Defense.

- **Secure (VSITR)**

Overwrites the entire hard disk with 00 next overwrites with FF after the data encryption key specified for the hard disk drive is erased. After repeating this process three times, the entire hard disk is overwritten with AA. It is virtually impossible to recover the overwritten data. Conforms to the guidelines of German Federal Government (VS-ITR).

- **Data deletion**

Selects the method to delete data on printer's hard disk.

➡ [Erasing Data on Printer's Hard Disk](#)

Monitoring service settings



This item is displayed when you select **Printer settings** on the Home screen.

»» Important

- The administrator password is required to change settings if it is enabled for changing settings using the operation panel.

- **Enable/disable monitoring service**

Selecting **Enable** allows the printer to send error details to the service center.

When selecting **Enable**, perform a communication test.

- **Communication test**

Performs a communication test with the service center.

- **Communication log**

Displays a list of error numbers (up to 30), the error code, and time the error occurs. Selecting an error number displays the error details.

Main errors and countermeasures

Error code	Error detail	Countermeasure
0xxx0003	Communication test is not performed.	Perform the communication test.
8xxx0003	E-RDS switch is setting OFF.	Enable monitoring service.
8xxx2003	Network is not ready, try later.	Check the network settings.
8xxx200A	Server connection error	Check the network settings.
8xxx2014	Proxy connection error	Check the proxy server address etc.
8xxx201E	Proxy authentication error	Check the user name and password to log in to the proxy server.
8xxx2046	Server certificate expired	The server certificate has expired. Set the correct date and time on the printer.
8xxx2047	Server response time out	Check the network settings. Check the proxy server address. Make sure that the correct date and time is set on the printer.
8xxx2058	Unknown error	Wait a while, and then try the communication test again.

- **Timing for ink level notification**

Sets the timing for ink level notification to the local service center.

Selecting **Check settings** allows you to check the notification timing set for each color.

- **Warning notification settings**

Displays a message on the touch screen selecting **Enable** when communication with the service center fails.

Other printer settings



This item is displayed when you select **Printer settings** on the Home screen.

▶▶ Important

- The administrator password is required to change settings if it is enabled for changing settings using the operation panel.

• Energy saving settings

To save electricity, enable this setting to turn off the printer automatically or to enter sleep mode when specified length of time has elapsed.

◦ Auto power off

Sets the time until the printer turns off automatically. If no operations are performed on the printer for the specified duration of the time after entering Sleep mode, the printer automatically turns off.

◦ Sleep timer

Specifies the length of time to enter sleep mode automatically when no operation is made.

▶▶ Note

- If the print job contains a pending job or a security print job, the printer does not enter sleep mode.

• Use USB connection

Use / Do not use USB connection.

• Date/time settings

Sets the current date and time.

• Date display format

Sets the format of dates displayed on the touch screen and printed on photos.

• Time zone (GMT)

Specifies the time zone according to a country or region you live in.

Specifying the time zone allows you to display the correct time and date an e-mail was sent on your mail software.

Select the time difference from GMT (Greenwich mean time) according to a country or region you live in.

• Length unit settings

Selects the length unit (meter or feet/inch).

• Buzzer settings

The printer beeps once for warnings and 3 times for errors when **Enable** is selected.

- **EOP timer settings**

Specify the timeout period before cancellation of print jobs that cannot be received by the printer.

- **Job history sending settings**

Select **Send** to send the information to the printer management and job management systems.

- **Menu row height**

Adjusts the line spacing of some setting items displayed on the touch screen.

Language selection



This item is displayed when you select **Printer settings** on the Home screen.

Changes the language for the messages and menus on the touch screen.

»» Important

- The administrator password is required to change the settings if it is enabled to change the settings on the operation panel using the administrator password.

Firmware update



This item is displayed when you select **Printer settings** on the Home screen.

You can update the firmware of the printer, check the firmware version, or perform settings of a notification screen, a DNS server and a proxy server.

»» Important

- The administrator password is required to change settings if it is enabled for changing settings using the operation panel.

»» Note

- If LAN is disabled, you cannot use **Install update**, **DNS server setup**, **Proxy server setup**.

- **Install update**

Updates the printer's firmware.

➔ [Firmware update](#)

- **Check current version**

You can check the current firmware version.

- **Update notification settings**

Select **Yes** to display a notification on the touch screen when a firmware update is available.

- **Show notifications (tool update)**

When you select **ON**, a confirmation screen is displayed on the touch panel before running the Firmware Update Tool.

- **DNS server setup**

Performs settings for a DNS server. Select **Auto setup** or **Manual setup**. If you select **Manual setup**, follow the display on the touch screen to perform settings.

- **Proxy server setup**

Performs settings for a proxy server. Follow the display on the touch screen to perform settings.

Security settings



This item is displayed when you select **Printer settings** on the Home screen.

»» Important

- The administrator password is required to change settings if it is enabled for changing settings using the operation panel.

• Administrator password settings

You can specify or disable the administrator password.

If you specify the administrator password, select the range and specify the administrator password.

Remote UI and other tools

Entering the administrator password is required to change the setting items using Remote UI or some software.

LCD, Remote UI, and other tools

Entering the administrator password is required to change the setting items using the operation panel of the printer, Remote UI, or some software.

For details:

➔ [Setting Administrator Password on Operation Panel](#)

• Operation restrictions

Restricts the following operations.

- **Job history**

Restricts to display or print the print job history.

- **Remote UI**

Restricts to use Remote UI.

- **Print from USB flash drive**

Restricts to print data on USB flash drive.

• IEEE802.1X/EAP settings

Performs various settings for IEEE802.1X/EAP.

Printer information

This item is displayed on the HOME screen.

- **System information**

Displays printer's system information.

- **Hard disk information**

Displays the total or free space of the printer hard disk.

- **Error history**

Displays the error history.

- **Hardware error**

Displays the hardware error codes (up to 5).

- **Recoverable error**

Displays the recoverable error (e.g. paper or ink related error) codes (up to 5).

- **Paper feed/transfer error**

Displays the error codes for errors which occur during paper feed/transfer (up to 5).

Selecting an error code displays the error details.

For more on the error code, refer to [List of Support Code for Error](#).

- **Usage**

Displays the actual printer usage, such as the total print area.

- **Head information**

Displays the Print head serial number, elapsed days since the current Print head was installed, and dot count.

- **Head alignment performance log**

Displays the Print head alignment performance log (up to 5).

- **Values applied with auto settings**

Displays the print settings applied the last print job.

Setting Administrator Password on Operation Panel

The administrator password can be set or canceled.

Specifying the administrator password requires you to enter the password to use the items or change the settings below.

- **LAN settings**
- **Web service setup**
- **Auto maintenance settings**
- **Hard disk settings**
- **Monitoring service settings**
- **Other printer settings**
- **Language selection**
- **Firmware update**
- **Security settings**
- **Import/export settings**
- **Initialize printer settings**
- **Status print (administrator)**

Follow the procedure below to specify the administrator password.

»» Important

- The administrator password is set at time of purchase. The default password is the printer serial number (9 characters) which can be found on the sticker on the printer.



1. Select **Printer settings** on the HOME screen.

2. Select **Security settings**.

3. Select **Administrator password settings**.

If you have set an administrator password, enter the password.

4. Select **Change administrator password**.

5. Select the effective range of the administrator password.

Remote UI and other tools

To change the setting using the remote UI or a certain software, the administrator password needs to be entered.

LCD, Remote UI, and other tools

To change the setting using the operation panel of this printer, remote UI or a certain software, the administrator password needs to be entered.

6. Enter new administrator password.

»» Important

- When changing the password, the character is limited as follows.
 - Set the password using 4 to 32 characters.
 - Single-byte alphanumeric characters, spaces, umlaut characters, and the following symbols are available.
- ! @ # \$ % ^ & * _ ; : , . / ` = + ' " () { } [] < > |
 - From a security point of view, it is recommended to set the password of 8 characters or more in combination of alphanumeric characters.

7. Select **Apply**.

8. Enter the administrator password again.

9. Select **Apply**.

The administrator password is available.

When You Want to Disable the Administrator Password:



After selecting **Printer settings** on the HOME screen, select **Security settings > Administrator password settings > Remove administrator password**. Select either item and follow the on-screen instructions to perform settings.

Erasing Data on Printer's Hard Disk

»» Important

- The administrator password is required to change settings if it is enabled for changing settings using the operation panel.
- For a more secure method of preventing data recovery, we recommend physically or magnetically destroying the hard disk. In this case, the hard disk can no longer be used.
- Additionally, print jobs are not processed while data erasing is in progress.



1. Select **Printer settings** on HOME screen.

2. Select **Hard disk settings**.

If an administrator password is set, enter the password.

3. Select **Data deletion**.

4. Select erasing method.

Fast

Erases file management data for print job data stored on the printer's hard disk. Choose this method for relatively fast erasure. Because only the file management data is erased, the print job data itself is not erased.

Fast secure

Erases the data encryption key specified for the hard disk drive. Specifying the encryption key again does not allow you to read and use data saved in the past safely and fast. Select to erase highly confidential data.

Secure

Overwrites the entire hard disk with 00, FF, and random data (one time each) after the data encryption key specified for the hard disk drive is erased. Verification is performed to check if the data was correctly written. Choose this method to erase especially confidential data. It is virtually impossible to recover the overwritten data. Conforms to the DoD5220.22-M standard of the U.S. Department of Defense.

Secure (VSITR)

Overwrites the entire hard disk with 00 next overwrites with FF after the data encryption key specified for the hard disk drive is erased. After repeating this process three times, the entire hard disk is overwritten with AA. It is virtually impossible to recover the overwritten data. Conforms to the guidelines of German Federal Government (VS-ITR).

5. Confirm the message and select **Yes**.

Data on the hard disk are erased.

Status Print

You can print a "Status Print" report indicating the current status of the printer.

With "Status Print", information is printed regarding the printer firmware version, various settings, and the status of consumables.



1. On the HOME screen, select **Printer settings**.
2. Select **Test print**.
3. Select **Status print**.

▶▶▶ Note

- If you specify the administrator password, select **Status print (administrator)**.

4. Select **Yes**.

The printer starts printing.

The following information is included.

Items and values may vary depending on your model, firmware version, and printer settings.

Canon xxxxxxxxxxxxxxxxxxxx Status Print		Printer model
S/N		Printer serial number
Firm		Firmware version
Boot		Boot ROM version
Date		Date and time when the status print was output
Paper Info		
	Roll1 Media	Type of roll paper 1
	Roll2 Media	Type of roll paper 2
	Cut Sheet	Type of cut sheet
Job Menu		
	Job History	
	Log	Details of up to 5 jobs
Settings		
	Printer settings	
	Print settings	Setting values of Print head movable width setting , Prioritize paper size , and Magnification level for borderless
	Paper-related settings	Setting values of Paper-related settings

Device settings		
	Auto maintenance settings	Setting values of Auto maintenance settings
	Hard disk settings	Setting values of Hard disk settings
	Device user settings	Setting values of Other printer settings
	Web service setup	Setting values of Web service usage registration
	Language selection	Setting value of Language selection
	Firmware update notification	Setting values of Update notification settings
	Show notifications (tool update)	Setting values of Show notifications (tool update)
	Monitoring service settings	Setting values of Monitoring service settings
	Roll unit use setting	Setting values of Take-up mode

Maintenance		
	Color calibration	Setting values of Calibration guide settings

Usage Condition		
	Hard disk information	Values of Hard disk capacity and Job box free space
	Hardware error	History information of Hardware error
	Error	History information of Recoverable error
	Warning	Warning history information
	Jam	History information of Paper feed/transfer error
	Maintenance cartridge usage / Tank size / Remaining ink level	Information on maintenance cartridge usage / Ink tank size / Remaining ink amount
	Duty counter	Values of Duty counter

PARTS STATUS		
	COUNTER	Part status

Head information		
	HEAD LOT NUMBER/ DATE OF INSTALLATION	Information of Head information
	Head alignment performance log	History information of Head alignment performance log

COUNTER		
	MEDIA	Usage status by media
	THE NUMBER OF CUTS	Total number of cuts
	AFTER INSTALLATION	Number of days from the use start date

Changing Printer's Setting Using Web Browser

- **Start up Remote UI**
- **Changeable Setting Items Using Remote UI**
- **Setting Passwords Using Remote UI**
- **Registering Printer's Root Certificate to Web Browser for SSL Communication**
- **Registering Printer's Root Certificate to Local Computer for SSL Communication**
- **Generating Server Certificate**
- **Setting Mail Server**
- **Receiving Printer Status by E-mail**

Start up Remote UI

You can check the printer status and change the printer settings using the web browser on your smartphone, tablet, or computer.

To check the printer status and to change the printer settings, display "Remote UI" on the web browser.

▶▶▶ Note

- Remote UI is a software that enables you to perform operations, which are usually performed on the printer's operation panel, using a Web browser over a network.

LAN connection with the printer is required to use Remote UI.

- You can use Remote UI on the following OS and the web browser.

- iOS device

Web browser: iOS standard Web browser (Mobile Safari)

- iPadOS device

Web browser: iPadOS standard Web browser (Mobile Safari)

- Android device

Web browser: Android standard Web browser (Browser or Chrome)

- macOS device

OS: macOS Catalina 10.15.7 or later

Web browser: macOS standard Web browser (Safari)

- Windows device

OS: Windows 7 SP1 or later

Web browser: Microsoft Edge, Mozilla Firefox, Google Chrome

- Enable JavaScript and cookies in the web browser.

1. Check printer's IP address.

1. Select  **LAN settings** on the HOME screen.

2. Select the enabled LAN.

Diagonal lines are displayed for disabled LAN icons.

3. Check **IPv4 address**.

2. Open web browser on your smartphone, tablet, or computer and enter IP address.

Enter as following in the URL field of the web browser.

http://XXX.XX.X.XXX

Enter the IP address of the printer in "XXX.XX.X.XXX".

»»» Note

- If you have set a DNS host name, you can also enter this.

When you access, "Remote UI" will be displayed on the web browser on your smartphone, tablet, or computer.

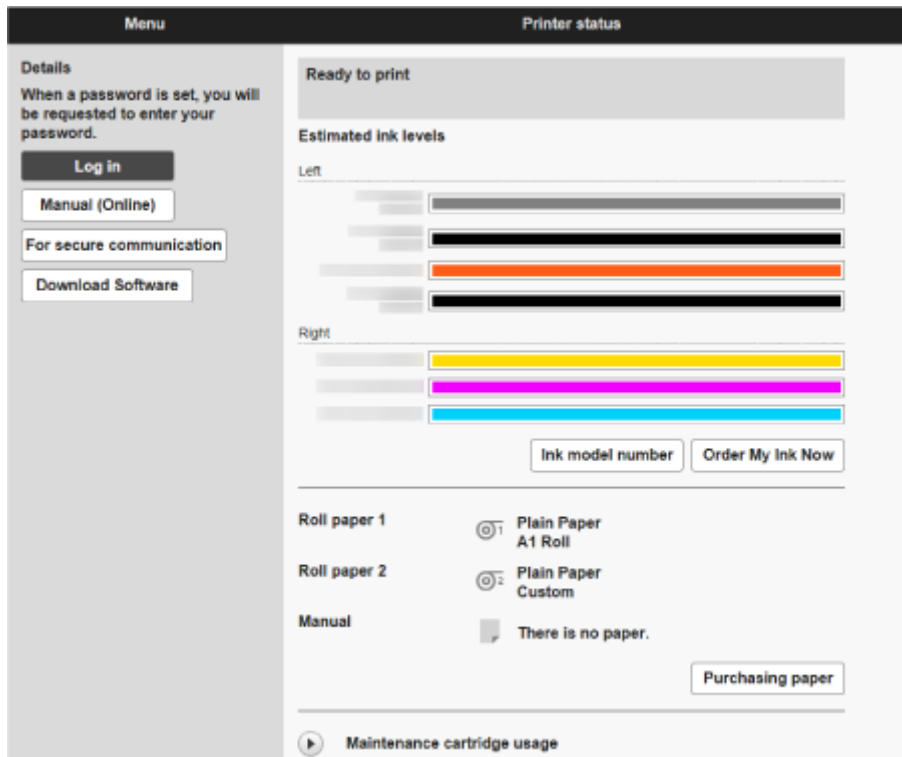

»»» Note

- If you display Remote UI for the first time on your smartphone, tablet, or computer, download the root certificate, and then register it.
 - ➔ [Registering Printer's Root Certificate to Web Browser for SSL Communication](#)
- If the root certificate is not registered, a message to warn you that the secure connection is not guaranteed may appear.

3. Select **Log in**.

The password authentication screen appears.

»»» Note

- When the standard user mode is enabled, choose either administrator mode or standard user mode to log on.
After choosing a mode and selecting **Log in**, the password authentication screen of each mode appears.

4. Enter password.

When the password authentication is complete, the menus that can be utilized are displayed on the web browser.

»» Important

- The password is set at the time of purchase. The password is the printer serial number. The printer serial number is printed on the sticker attached on the printer. It consists of 9 alphanumeric characters.

For details on setting password, see [Setting Passwords Using Remote UI](#).

5. Confirm that the main screen of Remote UI is displayed.

For changeable setting items, see below.

- ➔ [Changeable Setting Items Using Remote UI](#)

When you finish checking printer status and changing printer settings, select **Log out**.

Changeable Setting Items Using Remote UI

►►► Note

- The item which can be used is different in administrator mode or in standard user mode.

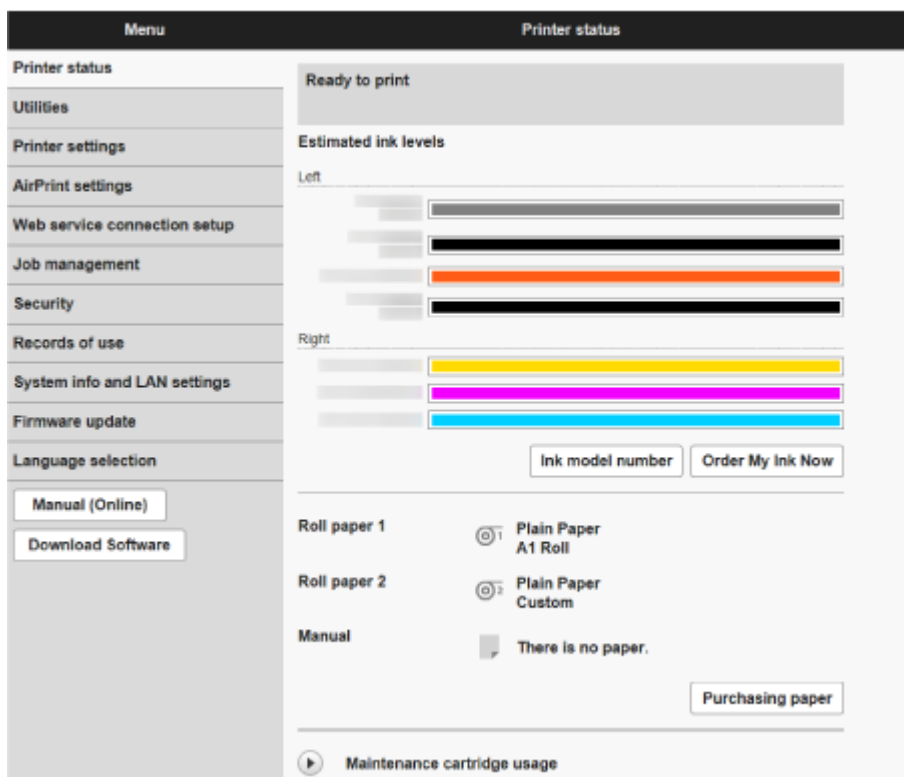

Printer status

This function displays printer information such as the remaining ink amount, the status, and detailed error information.

You can also connect to the ink purchase site or support page, and use Web Services.

Utilities

This function allows you to set and perform maintenance such as cleaning.

Printer settings

You can change various settings, such as print settings.

Additionally, this function allows you to receive the printer status information.

- ➔ [Setting Mail Server](#)
- ➔ [Receiving Printer Status by E-mail](#)

You can disable any operations using the operation panel from **Operation panel lock** on **Custom settings**.

►►► Note

- Some of the menu is available only when you logged on in administrator mode.

AirPrint settings

This function allows you to specify the AirPrint settings when printing with AirPrint.

Web service connection setup

This function configures web services that use printer device information, such as PIXMA/MAXIFY Cloud Link.

Job management

This function allows you to display the job history and print it.

▶▶▶ Note

- When you are logging on in administrator mode, you can restrict this function in standard user mode.

[Security](#) (Item for administrator)

Set passwords, make settings related to certificates for encrypted communication, and other security settings.

Records of use

Get information on printer usage.

System info and LAN settings

- **Confirm system information**
- [LAN settings](#) (Item for administrator)
- **Error history**

Firmware update

You can update the firmware of the printer, check the firmware version, or perform settings of a DNS server and a proxy server.

➡ [Firmware update](#)

Language selection (Item for administrator)

This function allows you to change the language on the display.

Manual (Online)

This function displays the Online Manual.

Security

- **Administrator password setting**

- ➔ [Setting Passwords Using Remote UI](#)

- **Standard user mode settings**

- Select Enable/Disable for the standard user mode.

- **Operation restrictions**

- Restricts the following operations.

- **Job history**

- Restricts to display or print the print job history.

- **Print from USB flash drive**

- Restricts to print data on USB flash drive.

- **TLS server settings**

- Make settings related to certificates for encrypted communication.

- Advanced TLS settings** enables you to specify the range of TLS versions to be used, the algorithm to be used, and so on.

- **IEEE802.1X/EAP settings**

- **Authentication**

- Select an authentication method for IEEE802.1X/EAP authentication.

- ▶▶▶ Note**

- In the case of using IEEE802.1X certificate, **Security > IEEE802.1X/EAP settings > CA certificate**, and register the CA certificate.
 - Supported authentication method
 - EAP-TLS(Extensible Authentication Protocol-Transport Level Security)
 - EAP-TTLS(EAP-Tunneled TLS)
 - PEAP(Protected EAP)

- **Key and certificate settings**

- Perform settings for key and client certificate.

- **CA certificate**

- Perform settings for the CA certificate that verifies a server certificate.

- **Enable/disable IEEE802.1X/EAP**

- Enable or disable IEEE802.1X/EAP authentication.

LAN settings

- **Wi-Fi**

Enables/Disables Wi-Fi.

- **Wireless Direct**

Enables/Disables Wireless Direct.

- **Wired LAN**

Enables/Disables Wired LAN.

- **Confirm LAN settings**

The LAN setting information is displayed.

- **Advanced setup**

- **Set printer name**

Specifies the printer name.

▶▶▶ Note

- You cannot use the same printer name as that already used for other LAN connected devices.
- You cannot use a hyphen for the initial or last character of the printer name.

- **TCP/IP settings**

Performs IPv4 or IPv6 setting.

- **WSD settings**

Perform settings to use WSD.

- **Bonjour settings**

Perform settings to use Bonjour.

- **LPD print**

Perform settings for printing with LPD.

- **SNMP settings**

Perform settings for using SNMP to manage and control the printer.

- **SNTP settings**

Perform settings for using SNTP to adjust the time on the printer.

- **FTP settings**

Perform settings for printing with FTP.

- **IPP Settings**

Perform settings for printing with IPP.

- **CHMP settings**

Perform settings for communication at the time when printer drivers or applications acquire the information on status, paper, and job log, from the printer.

Selecting **Enable HTTPS redirection** redirects the communication using CHMP to encrypted communication.

»» Note

- To use CHMP for encrypted communication, you need to register the printer's root certificate to your computer.
 - ➔ [Registering Printer's Root Certificate to Local Computer for SSL Communication](#)
- CHMP is a Canon proprietary protocol.

◦ **Network interface settings**

To connect to a hub that supports spanning tree, select **Spanning tree settings > Enable**.

Selecting **Enable** avoids circulating data on a network.

◦ **DRX settings**

When enabled, data is received intermittently during network connection.

◦ **IP filtering**

Allows or denies access for specific IP addresses.

Settings for both IPv4 and IPv6 addresses can be specified.

»» Important

- If the device address for the administrator has been set to rejection by mistake, select **LAN settings** on the HOME screen of the operation panel, and then select **Wi-Fi / Wireless Direct / Wired LAN > Settings > Advanced > Reset LAN settings** in this order, and initialize network information of the printer.

After resetting, perform setup again as necessary.



◦ **MAC address filtering settings**

Allows or denies access for specific MAC addresses.

»» Important

- If the device address for the administrator has been set to rejection by mistake, select **LAN settings** on the HOME screen of the operation panel, and then select **Wi-Fi / Wireless Direct / Wired LAN > Settings > Advanced > Reset LAN settings** in this order, and initialize network information of the printer.

After resetting, perform setup again as necessary.



◦ **Reset LAN settings**

Initializes the network settings on the printer.

After resetting, perform setup again as necessary.

Setting Passwords Using Remote UI

Each of passwords for administrator and standard user can be set.

When logging on with password for administrator, all settings can be changed.

When logging on with password for standard user, some of the settings can be changed.

➔ [Setting Administrator Password](#)

➔ [Setting Standard User Password](#)

▶▶▶ Note

- Password can be set only when you are logged in administrator mode.
- The standard user password is disabled by default.

Setting Administrator Password

Change the administrator password by following the steps below.

▶▶▶ Important

- The password is set at the time of purchase. The password is the printer serial number. The printer serial number is printed on the sticker attached on the printer. It consists of 9 alphanumeric characters.

1. Start up **Remote UI**.

➔ [Start up Remote UI](#)

2. Select **Security**.

3. Select **Administrator password setting**.

4. Select **Change administrator password**.

If an administrator password is not specified, the confirmation message appears. Confirm the message and select **Yes**. When message appears again, confirm it and select **OK**.

5. Select range where administrator password is valid and select **OK**.

Remote UI and other tools

Entering the administrator password is required to change the setting items using the Remote UI or some software.

Operation panel/Remote UI/other tools

Entering the administrator password is required to change the setting items using the operation panel of the printer, the Remote UI, or some software.

6. Enter password and select **OK**.

▶▶▶ Important

- The following character restrictions apply to the password:

- Set the password by using 4 to 32 characters.
- The allowed characters are single-byte alphanumeric characters, blank space, umlaut characters, and the below characters.
- ! @ # \$ % ^ & * _ ; : , . / ` = + ' " () { } [] < > |
- For security reasons, we recommend you use 8 and more alphanumeric characters.

7. When completion message appears, select **OK**.

Setting Standard User Password

For restricting the function for standard user, enable the standard user mode and set a standard user password by following the steps below.

1. Start up **Remote UI**.

➡ [Start up Remote UI](#)

2. Select **Security**.

3. Select **Standard user mode settings**.

4. Confirm the message and select **Yes**.

5. Enter password and select **OK**.

▶▶▶ Important

- The following character restrictions apply to the password:
 - Set the password by using 4 to 32 characters.
 - The allowed characters are single-byte alphanumeric characters, blank space, umlaut characters, and the below characters.
- ! @ # \$ % ^ & * _ ; : , . / ` = + ' " () { } [] < > |
 - For security reasons, we recommend you use 8 and more alphanumeric characters.

6. When completion message appears, select **OK**.

Registering Printer's Root Certificate to Web Browser for SSL Communication

If the printer's root certificate has not been registered to the web browser, a message to warn you that the secure connection is not guaranteed may appear.

When you display Remote UI for the first time on your smartphone, tablet, or computer, download the root certificate, and then register it to the web browser. The secure connection will be confirmed and a message will not appear. However, the message may appear depending on a web browser even after you have registered the root certificate.

How to register the root certificate varies depending on the web browser.

Operating procedure may differ depending on the version of your web browser. For other web browser, refer to each help.

▶▶▶ Important

- Make sure that you have accessed to the printer IP address correctly by checking the URL field of the web browser before registering the root certificate.
- If the printer is connected via IPv6 using Windows, you need to generate a server certificate using Remote UI.

For details, see [Generating Server Certificate](#).

For Microsoft Edge

1. Select **For secure communication** on Remote UI.

2. Select **Download**.

Downloading the root certificate is started.

3. If confirmation screen appears, select **Open**.

Certificate screen is displayed.

▶▶▶ Note

- To save the certificate file and register it, select **Save**. To register, select **Control Panel > Network and Internet > Internet Options**, and register the root certificate from **Certificates** on **Content** sheet.

4. Select **Install Certificate**.

Certificate Import Wizard screen is displayed.

5. Select **Next**.

6. Select **Place all certificates in the following store**.

7. Select **Browse**.

Select **Certificate Store** screen is displayed.

8. Select **Trusted Root Certification Authorities** and **OK**.

9. Select **Next** on **Certificate Import Wizard** screen.

10. If **Completing the Certificate Import Wizard** appears, select **Finish**.

Security Warning screen is displayed.

11. Make sure that thumbprint on **Security Warning** screen matches printer's thumbprint.

To display the printer's root certificate thumbprint in **Root cert. thumbprint (SHA-1)** or **Root cert.**

thumbprint (SHA-256), select  **Printer information** on the HOME screen of the operation panel, and then select **System information**.

12. If thumbprint on **Security Warning** screen matches printer's thumbprint, select **Yes**.

13. Select **OK** on **Certificate Import Wizard** screen.

The root certificate registration is completed.

For Safari

1. Select **For secure communication** on Remote UI.

2. Select **Download**.

Downloading the root certificate is started.

3. Open the downloaded file.

Keychain access starts up and **Add Certificates** screen is displayed.

4. Select **Add**.

Information on the certificate is displayed.

▶▶▶ Note

- You can also add the certificate by selecting **Show Certificate**, checking certificate name to add, and then selecting the same certificate on Keychain access.

5. Make sure that fingerprint of certificate detail information matches printer's thumbprint.

To display the printer's root certificate thumbprint in **Root cert. thumbprint (SHA-1)** or **Root cert.**

thumbprint (SHA-256), select  **Printer information** on the HOME screen of the operation panel, and then select **System information**.

6. If fingerprint of certificate detail information matches printer's thumbprint, display information on certificate from the menu or by double-clicking the certificate, and select **Always Trust** on **Trust**.

The root certificate registration is completed.

»» Note

- If a password is set on your device, entering a password may be required.

For Chrome on Android

1. Select **For secure communication** on Remote UI.

2. Select **Download**.

Downloading the root certificate is started and then **Name the certificate** screen is displayed.

3. As entering the root certificate name is required, enter an arbitrary certificate name and select **OK**.

The root certificate registration is completed.

»» Note

- If PIN or password is not set as security type, the attention screen may appear. Select **OK**, and then set the security type to PIN or password.

After Root Certificate Registration

We recommend that you make sure that the correct root certificate has been registered.

To make sure that the correct root certificate has been registered, make sure that thumbprint of certificate information matches printer's thumbprint. Follow the steps below.

»» Note

- Some Android devices cannot be checked the thumbprint of a registered route certificate.

1. From **Settings** menu on your device, select **Security, Trust credentials**, and **USER**.

The list of downloaded certificates appears.

2. Select downloaded certificate.

The certificate information appears.

3. Make sure that thumbprint of certificate information matches printer's thumbprint.

To display the printer's root certificate thumbprint in **Root cert. thumbprint (SHA-1)** or **Root cert.**

thumbprint (SHA-256), select  **Printer information** on the HOME screen of the operation panel, and then select **System information**.

4. If thumbprint of certificate information screen matches printer's thumbprint, select **OK**.

The root certificate registration is completed.

If the message to warn you that the secure connection is not guaranteed appears when you select **Log in** on Remote UI after registering the root certificate, restart the web browser. The message will not appear on the web browser.

▶▶▶ **Note**

- Depending on the Android device, a warning may appear even after registering the proper root certificate.

For Mobile Safari on iOS

1. Select **For secure communication** on Remote UI.

2. Select **Download**.

Downloading the root certificate is started and then **Install Profile** screen is displayed.

3. Select **Install**.

Warning screen is displayed.

▶▶▶ **Note**

- If a password is set on your device, entering a password may be required.

4. Select **Install**.

5. Select **Install** on displayed dialog.

The root certificate registration is completed.

Registering Printer's Root Certificate to Local Computer for SSL Communication

To use Device Management Console or Accounting Manager, etc. when you connect the printer to a computer using SSL encrypted communication, you need to register (import) the printer's root certificate to your computer.

Procedure to register the certificate varies depending on your operation environment.

▶▶▶ Important

- If the printer is connected via IPv6 using Windows, you need to generate a server certificate using Remote UI.

For details, see [Generating Server Certificate](#).

Operation procedure may differ depending on your OS version.

For Windows 11/Windows 10/Windows 8.1

The procedure below describes how to import a root certificate in Windows 11/Windows 10/Windows 8.1.

1. Start up Remote UI.

➔ [Start up Remote UI](#)

2. Select **For secure communication**.

▶▶▶ Note

- You can download a certificate from Status Monitor.

1. Open status monitor.

Open the **Printing preferences**, and select **Status Monitor...** on **Main**.

2. Download a certificate.

Select **Download Security Certificate** from the **Remote UI** menu.

3. Select **Download**.

The root certificate will be downloaded.

4. When download confirmation screen is displayed, select **Open**.

The **Certificate** screen appears.

5. Select **Install Certificate**.

The **Certificate Import Wizard** screen appears.

6. Select **Local Machine**.

1. Select **Local Machine** on the startup screen of **Certificate Import Wizard**.

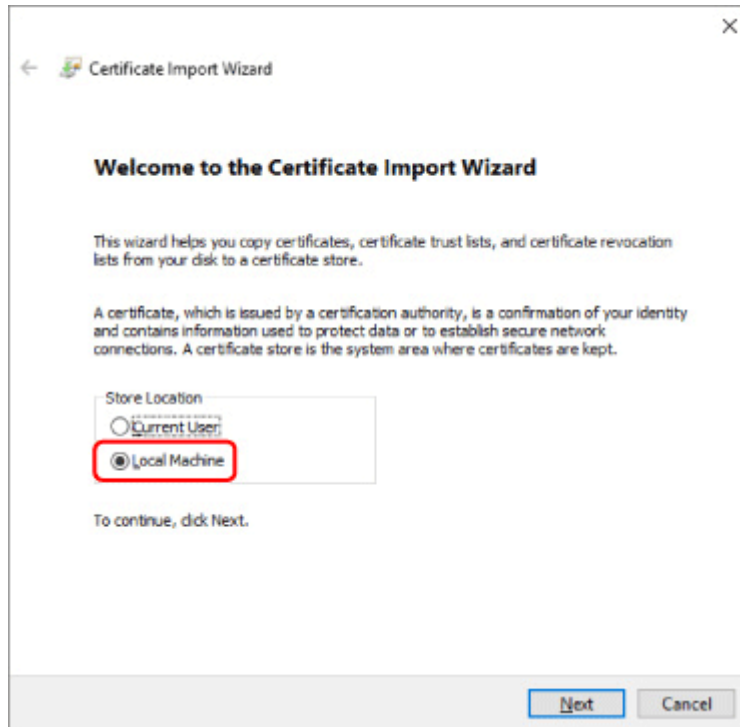

2. Select **Next**.
3. Select **Yes** on the displayed screen.

The **Certificate Store** screen appears.

7. Select **Place all certificates in the following store**.

8. Select **Trusted Root Certificate Authorities**.

1. Select **Browse** to open the **Select Certificate Store** screen.
2. Select **Trusted Root Certificate Authorities** from the list and select **OK**.
3. Select **Next** on the **Certificate Store** screen.

9. Select **Finish**.

When the **Completing the Certificate Import Wizard** screen appears, check the settings and select **Finish**.

For Windows 7

The procedure below describes how to import a root certificate in Windows 7.

►►► Important

- Be sure to create a certificate snap-in before importing a root certificate.

The root certificate will be registered to the local user if you import it without creating a certificate snap-in.

Creating Certificate Snap-in

1. Start up Microsoft Management Console.

Enter **MMC** on **Search programs and files** in the **Start** menu and press the Enter key.

2. Select **Yes** on displayed screen.

3. Select **Add/Remove Snap-in** from **File** menu.

The **Add or Remove Snap-ins** screen appears.

4. Add **Certificate** snap-in.

1. Select **Certificates** from **Available snap-ins** list and select **Add**.

2. Select **Computer account** for **This snap-in will always manage certificates for** on the **Certificates snap-in** screen and select **Next**.

3. Select **Local computer** on the **Select computer** screen and select **Finish**.

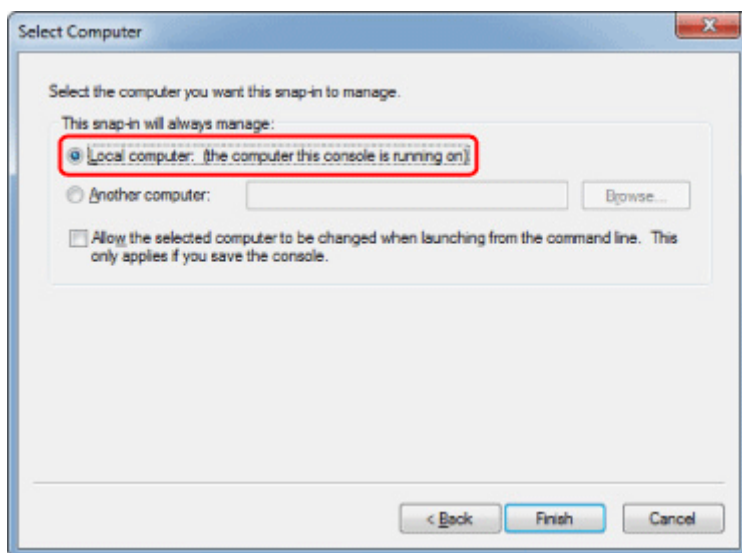

4. Select **OK** on the **Add or Remove Snap-ins** screen.

Downloading Certificate

1. Start up Remote UI.

➔ [Start up Remote UI](#)

2. Select **For secure communication**.

»» Note

- You can download a certificate from Status Monitor.

1. Open status monitor.

Open the **Printing preferences**, and select **Status Monitor...** on **Main**.

2. Download a certificate.

Select **Download Security Certificate** from the **Remote UI** menu.

3. Select Download.

4. Select Save.

Importing Certificate

1. Open Certificate Import Wizard.

1. On the left window, open **Trusted Root Certificate** from **Certificate** on **Console Root**.

2. Right-click **Certificates** and select **Import** from **All tasks**.

2. Specify certificate file to import.

1. Select **Next**.

2. Specify the certificate file to import on **File name** and select **Next**.

3. Specify certificate store.

1. Select **Place all certificates in the following store**.

2. Select **Trusted Root Certificate Authorities** for **Certificates Store**.

4. Finish certificate import wizard.

1. Select **Next** and check the specified settings.

2. Select **Finish** to finish the wizard.

3. Select **OK** on the displayed screen.

Checking Imported Certificate

Make sure the imported certificate has been registered to your computer.

1. Display certificate list.

On the left window of Microsoft Management Console, select **Console Root > Certificates (Local Computer) > Trusted Root Certificate Authorities** in this order, and Select **Certificates** to display the certificate list.

2. Check registered certificate.

Make sure the imported certificate name is displayed on the list.

▶▶▶ Note

- Make sure you can see the registered certificate from **Current user** by creating the **Current user** snap-in.

▶▶▶ Note

- When you finish Microsoft Management Console, a message asking you whether to save the console setting. If you continue to apply the same settings next, select **Yes** to save.

For macOS

The procedure below describes how to import a root certificate in macOS.

1. Start up Remote UI.

➔ [Start up Remote UI](#)

2. Select **For secure communication**.

3. Select **Download**.

The root certificate will be downloaded.

4. Open downloaded certificate file.

When the download procedure is completed, a downloaded item pops up on the right of the screen.

Double-click the downloaded certificate on the list starts up **Keychain Access** and the **Add Certificates** screen appears.

▶▶▶ Note

- If the downloaded item does not pop up, select the **Show Downloads**  button on the right.
- Selecting the magnifying glass icon on the right of download list displays the folder containing the certificate.

5. Select **Add**.

Select the destination for the certificate on **Keychain**.

Selecting **Add** displays information on the certificate.

▶▶▶ Note

- You can add the certificate by selecting the same certificate on **Keychain Access**. Check the name of certification to add after selecting **View Certificates**.

6. Check certificate.

Make sure the fingerprint of certificate shown on **Details** corresponds with the root certificate thumbprint of the printer.

To display the printer's root certificate thumbprint in **Root cert. thumbprint (SHA-1)** or **Root cert.**

thumbprint (SHA-256), select  **Printer information** on the HOME screen of the operation panel, and then select **System information**.

7. Select **Always Trust**.

If the fingerprint of certificate detail information matches printer's thumbprint, display information on certificate from the menu or by double-clicking the certificate, and select **Always Trust** on **Trust**.

The root certificate has been registered.

▶▶ Note

- Entering the password may be required if you specify it for your printer.

Generating Server Certificate

When you use SSL connection via IPv6 network, you need to generate an IPv6 server certificate using the printer.

Generate the server certificate from Remote UI.

Follow the procedure below.

1. [Checking Printer's IP Address](#)
2. [Generating Server Certificate](#)
3. [Checking Generated Server Certificate](#)

»» Important

- If you generate an IPv6 server certificate, a warning message may appear if you are using Remote UI.
To reset the IPv6 server certificate, select **Security > TLS server settings > Delete key and certificate** in this order, and select **OK** on the displayed screen.

Checking Printer's IP Address

1. Select  **LAN settings** on the HOME screen.

2. Select the enabled LAN.

Diagonal lines are displayed for disabled LAN icons.

3. Check the value on **IPv6 link-local address**.

Write down the value on **IPv6 link-local address** for your reference when you generate a server certificate.

Generating Server Certificate

1. Start up Remote UI.
➔ [Start up Remote UI](#)
2. Select **Security**.
3. Select **TLS server settings**.
4. Select **Generate key and certificate**.
5. Select **Generate self-signed cert**.
6. Specify each setting item.

- **Key algorithm**

Specify the signature algorithm and key information.

- Specify the expiration date.

Enter the date you generated the server certificate on **Valid from**.

Enter the date the server certificate expires on **Valid to**.

- Enter the common name.

On **Common name**, enter the **IPv6 link-local address** you checked in abbreviated form.

»» **Note**

- When you enter the common name, add [] to each end of the abbreviation value of the printer's IPv6 address.
- Do not use a comma or make a space for the common name.

7. Select Next.

Enter **Country**, **State or province**, **Locality**, **Organization** and **Organizational unit** as required.

Enter the same information in **Subject Alternative Names** as in **Common name**.

8. Select Generate.

The server certificate starts to be generated.

When the server certificate has been generated, **Generated a self-signed certificate** appears.

9. Select Restart LAN.

LAN will be restarted.

When LAN has been restarted, **Printer status** on Remote UI appears.

»» **Note**

- If you cannot access to Remote UI after you restart LAN, reload your web browser.

Checking Generated Server Certificate

1. Select Security on Remote UI.

2. Select TLS server settings.

3. Select Check key and certificate.

Make sure the issuer of the root certificate is displayed on **Issued by**, and the value you entered is displayed on **Common name** on **Subject**.

Setting Mail Server

To use mail function, specify the mail server settings.

*This function may not be available depending on the country or region of purchase.

▶▶▶ Note

- If you did not specify the time zone setting using the printer's operation panel, a message to inform you that the correct time may not be reflected on the sent e-mail appears. We recommend that you set the time zone setting using the printer's operation panel.

➡ [Other printer settings](#)

- These functions can be set only when you are logged in administrator mode.

1. Launch the remote UI.

➡ [Start up Remote UI](#)

2. Select **Printer settings**.

3. Select **Set mail server**.

4. Specify mail server settings.

Specify the following items.

- **Sender address**

Enter the e-mail address of the sender (this printer).

- **Outgoing mail server (SMTP)**

Enter the address of your SMTP server.

- **Port number (SMTP)**

Enter the port number of your SMTP server.

- **Secure connection (SSL)**

Select if you use the secure connection (SSL).

- **Don't verify certificates**

Select if you do not verify the certificate.

- **Authentication**

Select one of the following authentication methods.

- **SMTP authentication**

Select if you send e-mail with SMTP authentication.

Next, you can specify the following settings.

- **Outgoing account**

Enter the account name for sending to perform the authentication.

- **Outgoing password**

To set / change the password for sending in order to perform the authentication, check the **Set/change password** and then enter the password.

◦ **POP before SMTP**

Select if you send e-mail with POP before SMTP authentication.

Next, you can specify the following settings.

▪ **Incoming mail server (POP3)**

Enter the address of your POP server.

▪ **Port number (POP3)**

Enter the port number of your POP server.

▪ **Incoming account**

Enter the account name for receiving to perform the authentication.

▪ **Incoming password**

To set / change the password for receiving in order to perform the authentication, check the **Set/change password** and then enter the password.

▪ **Use APOP authentication**

Select if you send the password by the encryption transmission.

▪ **Clear mailbox**

Select if you delete the e-mails that remain in the POP3 server.

»» Important

- When this setting is enabled, e-mail in the Inbox on the server will have all been removed. If you specify the e-mail address of your everyday, be sure to disable this setting as unread e-mail is not deleted. We recommend that you prepare this printer dedicated e-mail account not to accidentally delete the unread e-mail.

◦ **No authentication**

Select if the authentication is not necessary.

5. Select OK.

The setting operation is completed.

Receiving Printer Status by E-mail

You receive the printer status information such as the remaining ink level and the error from the printer.

* This function may not be available depending on the country or region of purchase.

▶▶▶ Note

- Specify the mail server settings in advance.
 - ➔ [Setting Mail Server](#)
- If you did not specify the date and time setting using the printer's operation panel, the date and time may not be reflected on the sent e-mail. We recommend that you set the date and time setting using the printer's operation panel.

For the date and time setting, see [Other printer settings](#).
- These functions can be set only when you are logged in administrator mode.

1. Start up Remote UI.

- ➔ [Start up Remote UI](#)

2. Select **Printer settings**.

3. Select **Status notification email**.

4. Select **Notification recipients**.

5. Specify destination settings.

Up to 5 destinations can be registered by following the steps below.

1. Select number of destination.
2. Select **Add**.
3. Enter e-mail address, and then select printer status to send information.
4. Select **OK**.

The registration for destination is completed.

6. Select **Printer settings**.

7. Select **Status notification email**.

8. Select **Retry settings**.

9. Specify resending settings.

The number of resending can be specified by following the steps below.

1. Specify number of resending.
2. Specify interval of resending.
3. Select **OK**.

The resending setting is completed.

Migrating Printer's Setting

Migrates the printer settings to another one of the same model.

This operation is available either from the Remote UI or from the operation panel using a USB flash drive.

➔ [Using Remote UI](#)

➔ [Using USB Flash Drive](#)

▶▶▶ Note

- The printers must be running the same firmware version. The target data to be migrated is fixed.

Using Remote UI

1. Exporting settings

1. Start up Remote UI.
➔ [Start up Remote UI](#)
2. Select **Printer settings**.
3. Select **Import/Export printer settings**.
4. Select **Export printer settings**.
5. Enter password and select **OK**.

2. Importing settings

1. Start up Remote UI
➔ [Start up Remote UI](#)
2. Select **Printer settings**.
3. Select **Import/Export printer settings**.
4. Select **Import printer settings**.
5. Select a file to import.
6. Enter password and select **OK**.

Using USB Flash Drive

1. Exporting settings

1. Insert USB flash drive into the USB flash drive connector.

2. Select  **Printer settings** on HOME screen.
3. Select **Import/export settings**.
If you specify the administrator password, enter the password.
4. Select **Export**.
5. Enter password and select **Apply**.
6. Enter password again.

2. Importing settings

1. Insert a USB flash drive to USB flash drive port.
2. Select  **Printer settings** on HOME screen.
3. Select **Import/export settings**.
If you specify the administrator password, enter the password.
4. Select **Import**.
5. Enter password and select **OK**.

Initializing Printer's Setting

Initializes the following settings.

- Paper setting information
- Detection priority data of paper
- SSL certificate
- LAN setting
- Administrator password
- Hard drive data
- Job history
- Operation panel lock
- Web service usage settings
- Display settings for the screen confirming update from the Firmware Update Tool

This operation is available using the operation panel or Remote UI.

➔ [Using operation panel](#)

➔ [Using Remote UI](#)

Using operation panel



1. Select **Printer settings** on HOME screen.
2. Select **Initialize printer settings**.
If you specify the administrator password, enter the password.
3. Confirm the message and select **Yes**.

Using Remote UI

1. Start up Remote UI.
➔ [Start up Remote UI](#)
2. Select **Printer settings**.
3. Select **Initialize printer settings**.
4. Confirm the message and select **Yes**.
The Remote UI is disconnected.

Network Setting

- **Printer Connection Methods**
 - Wi-Fi Connection
 - Wireless Direct Connection
 - Wired Connection
 - USB Connection
- **Another Printer Found with Same Name**
- **Printing Network Settings**
- **Countermeasures against Unauthorized Access**
- **Network Status and Troubleshooting**
- **Checking Printer Connection Status Using Wi-Fi Connection Assistant**
- **Sharing the Printer on a Network (Windows)**
 - Setting Up a Shared Printer
 - Restrictions on Printer Sharing
- **Sharing the Printer on a Network (macOS)**
 - Settings on Print Server
 - Settings on Client PC
 - Restrictions on Printer Sharing

Printer Connection Methods

4 connection methods are available on the printer.

- [Wi-Fi Connection](#)



- [Wireless Direct Connection](#)



- [Wired Connection](#)

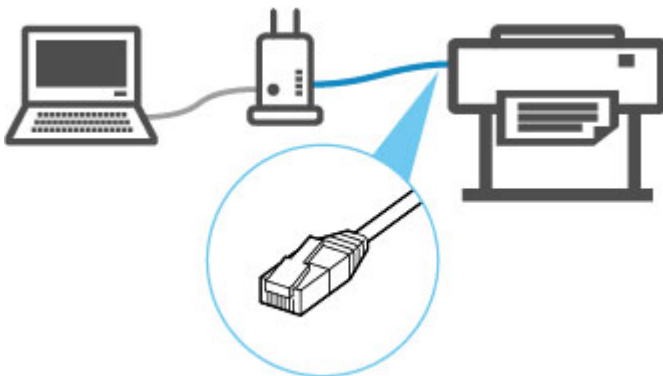

- [USB Connection](#)

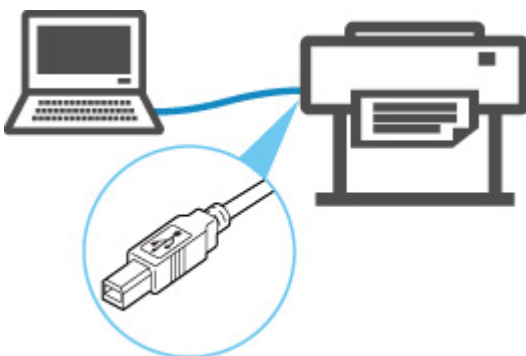

The printer cannot use a wired LAN connection simultaneously with a Wi-Fi or wireless direct connection. When connecting another device while the devices are already connected to the printer, connect using a method other than the above.

➔ Restrictions

»» Important

- If you connect a device connected to the Internet via a wireless router to the printer that is in the wireless direct, the connection between the device and wireless router will be disabled. In that case, the connection of the device may switch to a mobile data connection automatically depending on your device. Transmission fees for connecting to the Internet using a mobile data connection apply.



Wi-Fi Connection

Important

- If printer is performing cleaning, print head alignment, or other processes, wait for the process to finish, before starting setup.

Note

- Refer to the following notes when connecting to Wi-Fi.
 - ➔ Notes on Wi-Fi Connection

1. If  is displayed on the left side of the screen, tap  to display the HOME screen.

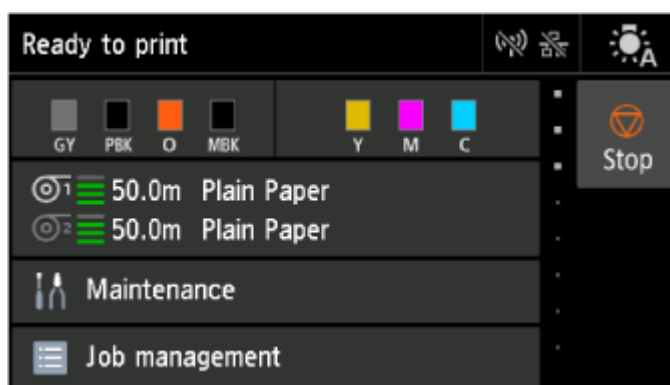

Note

- If an error screen appears, select **OK**, and then tap .

2. Select  **LAN settings** on HOME screen.

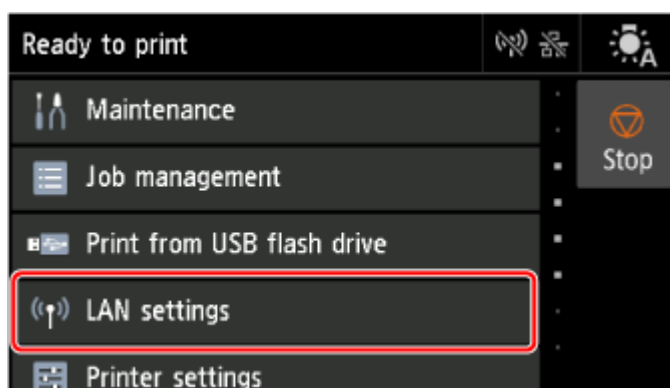

3. Select **Wi-Fi**.



4. Select **Settings**.



5. Select **Wi-Fi setup**.



6. Select a connection method below.

Easy wireless connect

Set wireless router information to the printer directly from a device (such as a computer), without operating the wireless router

Easy wireless connect may take some time. Internet connection may become temporarily unavailable during setup.

Easy wireless connect is not available on Windows 10 in S mode or Windows 11 in S mode.
Select other connection type.

Manual connect

Connect to wireless router using a password

WPS

Connect to a WPS-compatible wireless router

WPS (PIN Code) Connection

A wireless connection can also be set up by using the WPS PIN code method

WPS Connection

1. Select **WPS (Push button method)**.

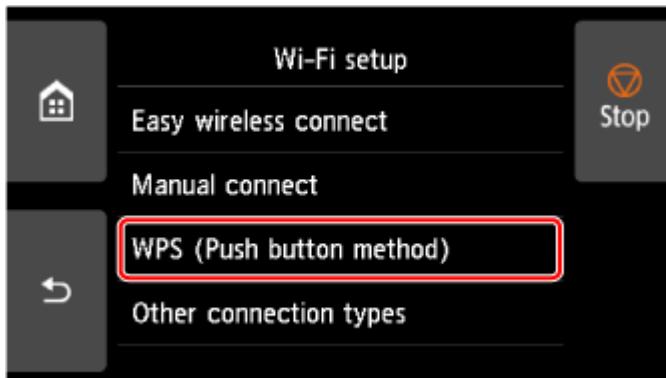

2. Select **OK**.



3. Press and hold the WPS button on the wireless router.

▶▶▶ Note

- For more on pressing the WPS button, see the wireless router manual.

4. Select **OK** on the printer within 2 minutes.

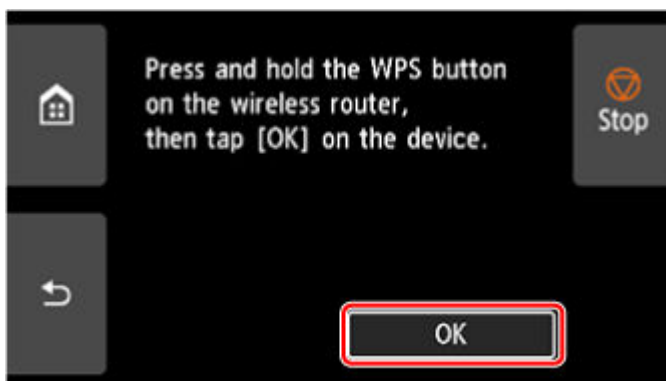

5. When the screen on the below appears, select **OK**.



6. Tap  on the left side of the screen.

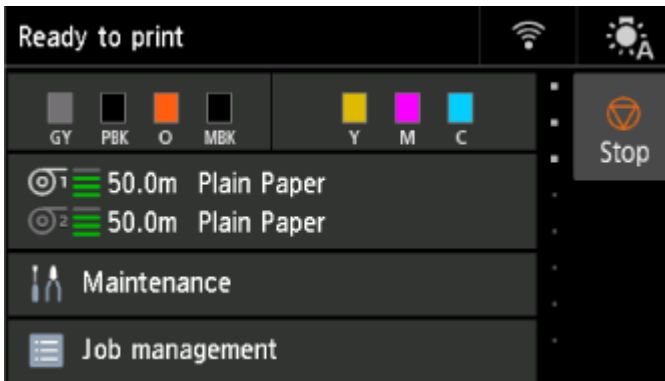



[The network connection setup is now complete.](#)



Once connection is complete,  appears on the screen.

If performing setup with software, return to the software and proceed with the installation.

Windows

Click  (or ) on the  taskbar at the bottom of the screen, follow the on-screen instructions to proceed with setup.

macOS

Click  on the  Dock at the bottom of the screen, and follow the on-screen instructions to proceed with setup.

WPS (PIN Code) Connection

1. Select **Other connection types**.

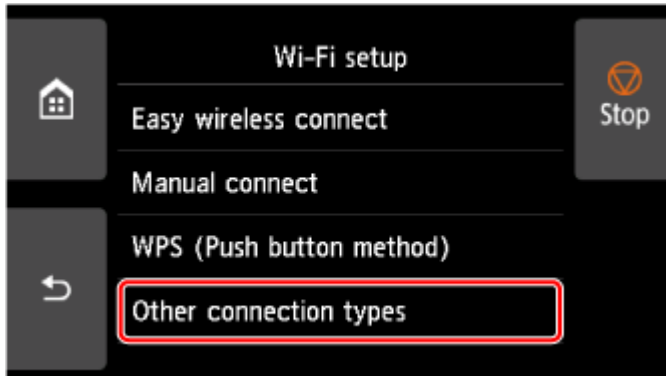

2. Select **WPS (PIN code method)**.

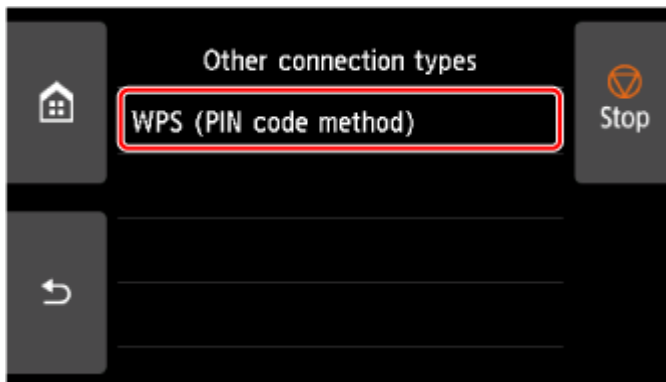

3. Follow the on-screen instructions on a computer to set a PIN code on the wireless router.

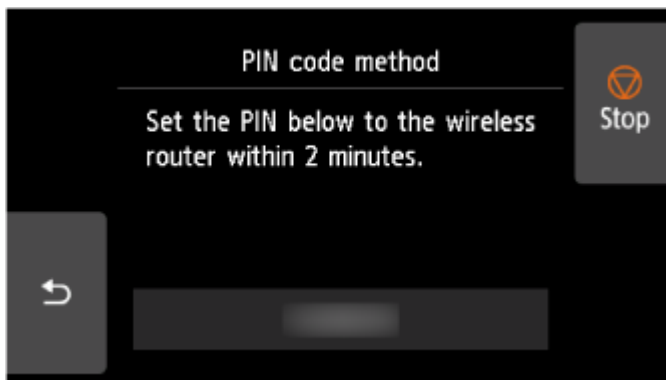

4. When the screen on the below appears, select **OK**.



5. Tap  on the left side of the screen.

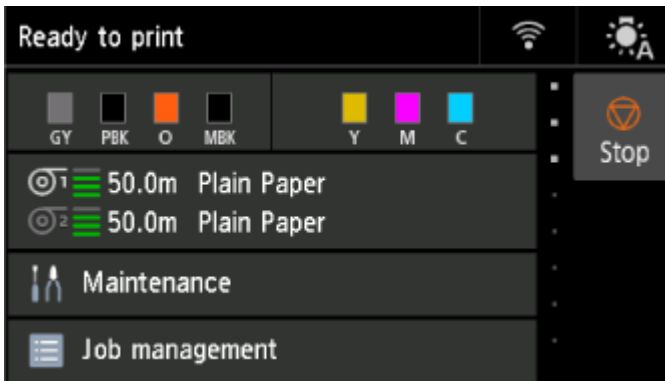



[The network connection setup is now complete.](#)



Once connection is complete,  appears on the screen.

If performing setup with software, return to the software and proceed with the installation.

Windows

Click  (or ) on the  taskbar at the bottom of the screen, follow the on-screen instructions to proceed with setup.

macOS

Click  on the  Dock at the bottom of the screen, and follow the on-screen instructions to proceed with setup.

Manual connect

1. Select **Manual connect**.

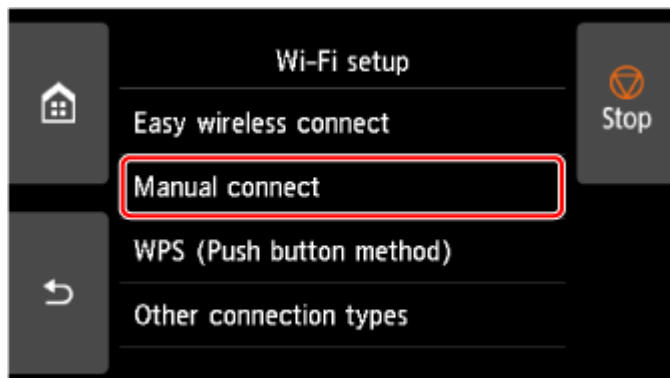

2. Select your wireless router.

If you select a Wi-Fi router name, proceed to step 8 and continue with the settings.

If you select [Directly enter the wireless router name], proceed to step 3 and continue with the settings.

If [Failed to connect to the wireless router.] appears, see ["Failed to connect to the wireless router." Appears.](#)

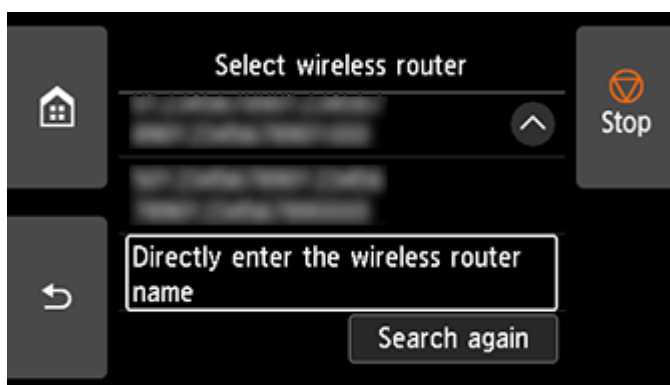

3. Select the input area.

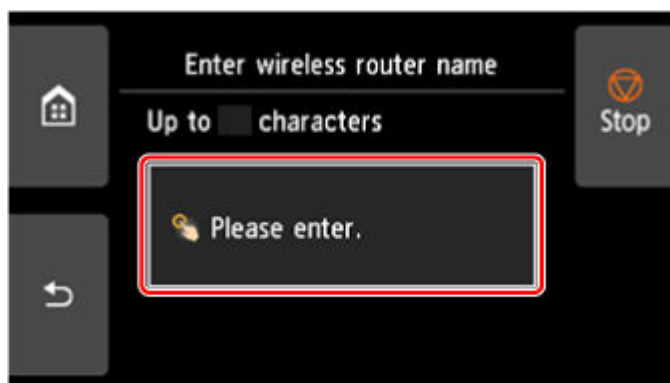

4. Enter the wireless router name (SSID). Text entry is case-sensitive.

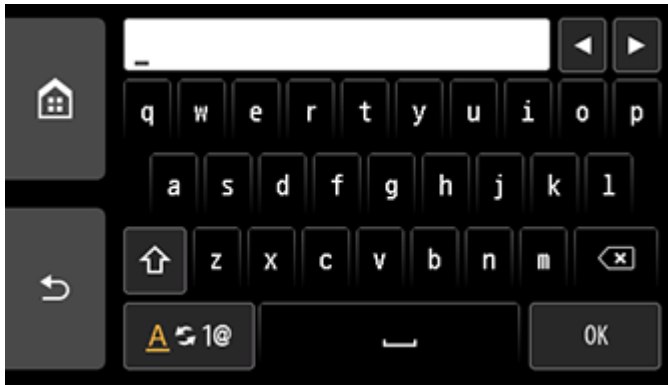

If you don't know your wireless router name, see the wireless router manual or contact its manufacturer.

5. Select **OK**.

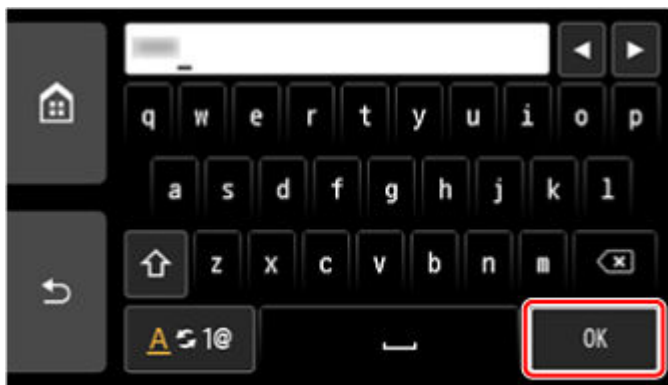

6. Make sure the wireless router name (SSID) is correct.

7. Select **OK**.

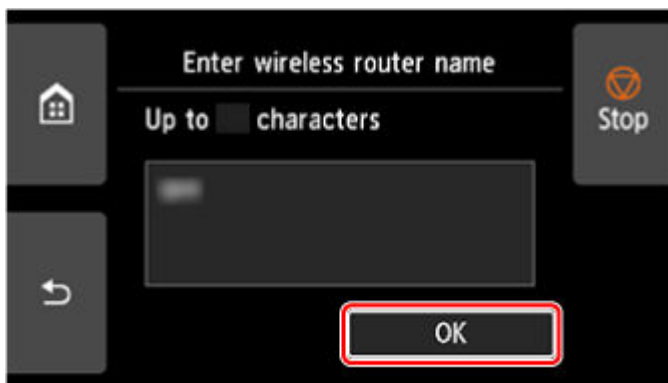

8. The screen below will appear.

If "**Connected to the wireless router.**" appears, the network does not require a password. Continue from step 13.

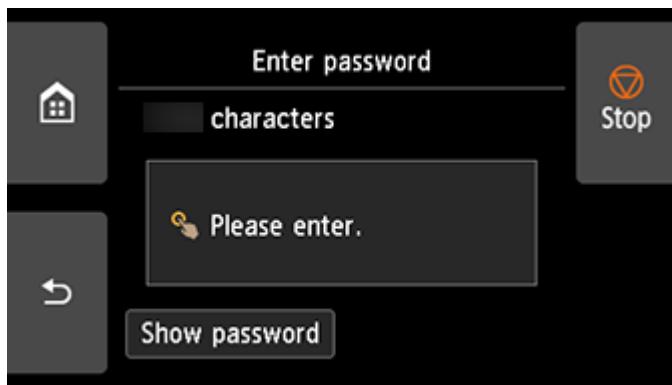

9. Select the input area.

10. Enter the password. Text entry is case-sensitive.

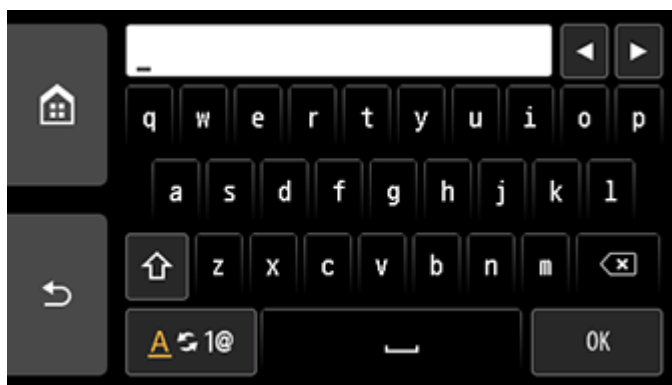

If you don't know the password for your wireless router, see the wireless router manual or contact its manufacturer.

11. Select OK.

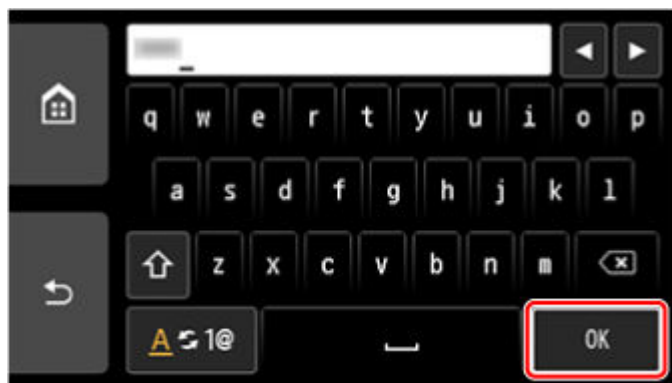

12. Select OK.



13. When the screen on the below appears, select **OK**.



14. Tap  on the left side of the screen.



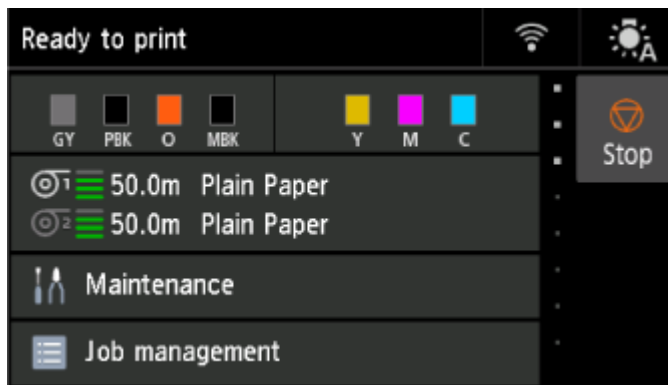



The network connection setup is now complete.





Once connection is complete,  appears on the screen.

If performing setup with software, return to the software and proceed with the installation.

Windows

Click  (or ) on the  taskbar at the bottom of the screen, follow the on-screen instructions to proceed with setup.

macOS

Click  on the  Dock at the bottom of the screen, and follow the on-screen instructions to proceed with setup.

Easy wireless connect

1. Select **Easy wireless connect**.

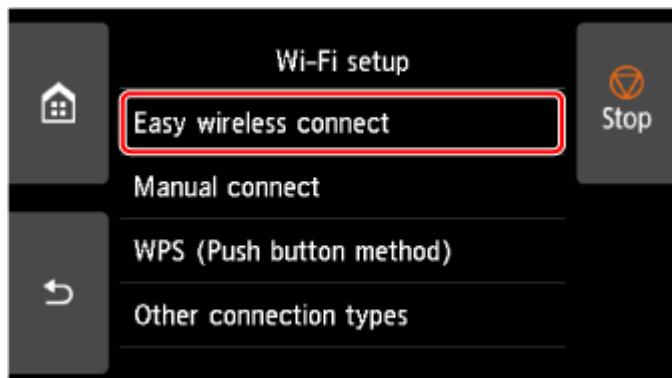

2. Select **OK**.



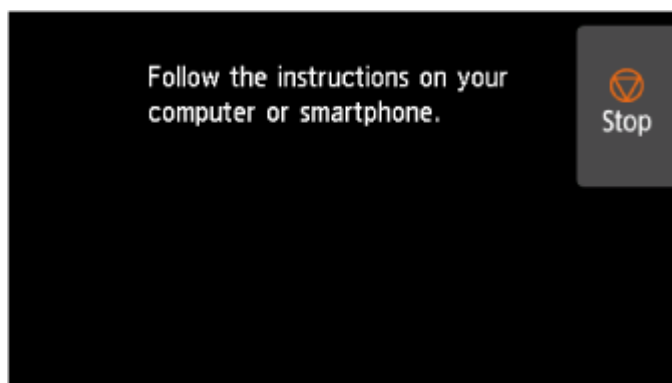

3. When the printer preparation is complete, the screen below appears.





4. Return to the application software and proceed with the setup.

Windows

Click  (or ) on the  taskbar at the bottom of the screen, follow the on-screen instructions to proceed with setup.

macOS

Click  on the  Dock at the bottom of the screen, and follow the on-screen instructions to proceed with setup.

Wireless Direct Connection

This section describes wireless direct, which allows you to print by connecting the devices to the printer directly.

▶▶▶ Important

- Check the usage restrictions and switch the printer to the wireless direct.
 - ➔ Restrictions
- The administrator password is required to change settings if it is enabled for changing settings using the operation panel.
- If a device has already been connected to the printer directly and you want to add a device to connect, connect it to the printer directly. You can connect up to 5 devices to the printer at the same time.

Enable Wireless Direct

1. Select  **LAN settings** on HOME screen.

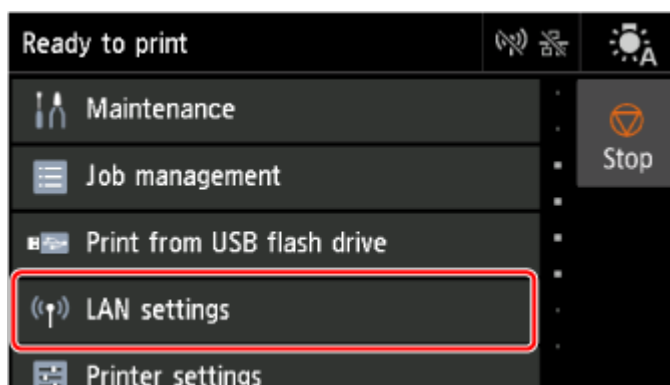

2. Select **Wireless Direct**.



3. Select **Settings**.

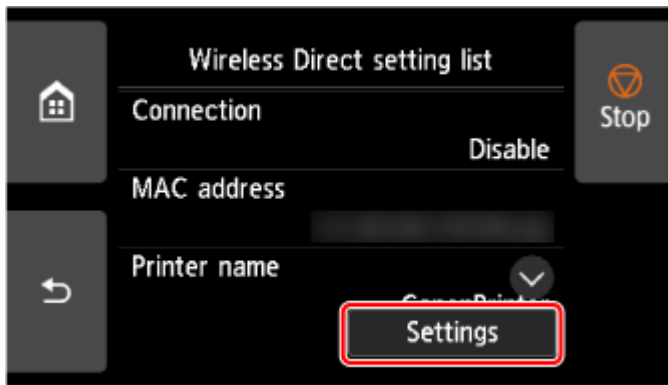

4. Select **Enable/disable Wireless Direct**.



5. Select **Yes**.

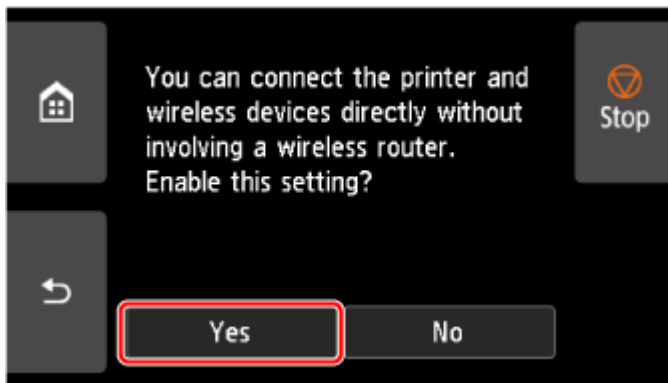

After Wireless Direct is enabled, the identifier (SSID) etc. when using the printer with wireless direct connection are displayed.

By flicking the touch screen, you can check various settings of wireless direct.

▶▶▶ Note

- The identifier (SSID) and password are specified automatically.
- You can check the password set for the printer by the following method.

1. Select  **LAN settings** on HOME screen.
2. Select **Wireless Direct**.

3. Select **Show password**.

• By selecting **Wireless Direct**, you can change the following settings.

- **Enable/disable Wireless Direct**
- **Change network name (SSID)**
- **Change password**
- **Connection request confirmation**

For updating the SSID / password or changing the name of the printer displayed on Wi-Fi Direct compatible device, see [Change Wireless Direct Connection Setting](#).

Connecting Smartphone/Tablet to Printer

1. Turn on Wi-Fi communication on Wi-Fi Direct compatible device.

For more on turning on Wi-Fi communication, see your device's instruction manual.

2. Select "DIRECT-XXXX-XX-XXXX" ("X" represents alphanumeric characters.) from list displayed on device.

▶▶▶ Note

- If "DIRECT-XXXX-XX-XXXX" does not appear on the list, wireless direct is not enabled.
See [Enable Wireless Direct](#) to enable wireless direct.
- You can change the name of the printer displayed on Wi-Fi Direct compatible devices.
See [Change Wireless Direct Connection Setting](#) as necessary.

3. Enter password on Wi-Fi Direct compatible device.

The device is connected to the printer.

▶▶▶ Note

- You can check the password set for the printer by the following method.

1. Select  **LAN settings** on HOME screen.
2. Select **Wireless Direct**.
3. Select **Show password**.

- If your Wi-Fi Direct compatible device is set to prioritize using Wi-Fi Direct and it is connecting to the printer, the printer displays a confirmation screen asking if you allow the device to connect to the printer.

Make sure the name on the touch screen is the same as that of your Wi-Fi Direct compatible device and select **Yes**.

Change Wireless Direct Connection Setting



1. Select **LAN settings** on HOME screen.

2. Select **Wireless Direct**.

3. Select **Settings**.

4. Change settings as necessary.

- To update the password for wireless direct

Select **Change password** to display the confirmation screen.

To check the updated password, select **Change manually > Show password**.

- To change the printer's name displayed on the Wi-Fi Direct compatible device

Select **Change network name (SSID)** to display the printer's name (the initial value is "DIRECT-XXXX-XX-XXXX") displayed on a Wi-Fi Direct compatible device.

Follow the procedure below to change the name.

1. Select the device name entry field on the touch screen.
2. Enter device name.
3. Select **OK** and confirm the entered device name.
4. Select **OK**.

- To change the confirmation screen setting when a Wi-Fi Direct compatible device is connecting to the printer

Select **Connection request confirmation** to display the confirmation screen.

If you want the printer to display the screen to inform you a Wi-Fi Direct compatible device is connecting to the printer, select **ON**.

Important

- To prevent an unauthorized access, we recommend you should not change the setting from the default.

When you finished performing the settings, the printer returns to the **Wireless Direct settings** screen.

Note

- If you change the wireless direct setting on the printer, also change the setting on the device.

Wired Connection



Important

- If printer is performing cleaning, print head alignment, or other processes, wait for the process to finish, before starting setup.

Note

- Refer to the following for notes when connecting to a wired LAN.

➔ Notes on Wired Connection

1. If  is displayed on the left side of the screen, tap  to display the HOME screen.

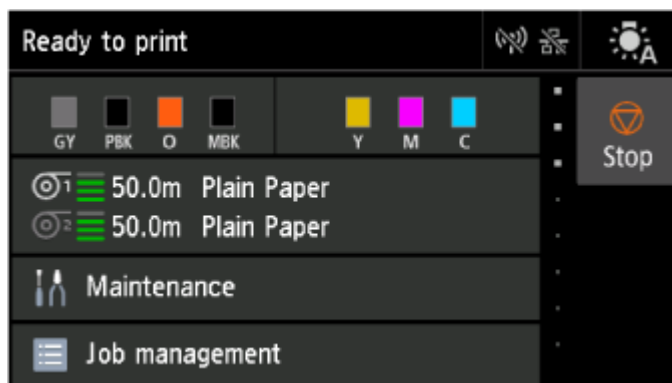

2. You will need an Ethernet cable (sold separately).

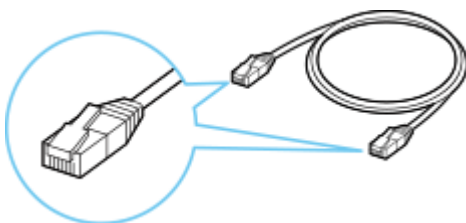

3. Connect the printer and a network device (router, etc.) with an Ethernet cable.

Do not connect to any other port.

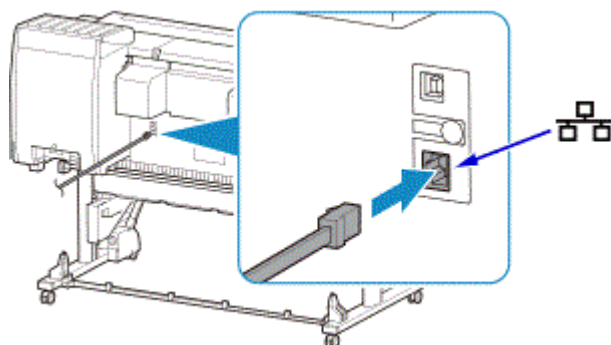

4. Select  LAN settings on HOME screen.

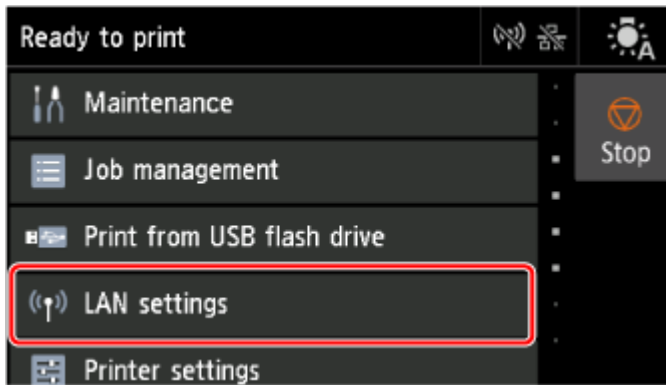

5. Select **Wired LAN**.



6. Select **Settings**.



7. Select **Enable/disable Wired LAN**.



8. Select **Enable**.

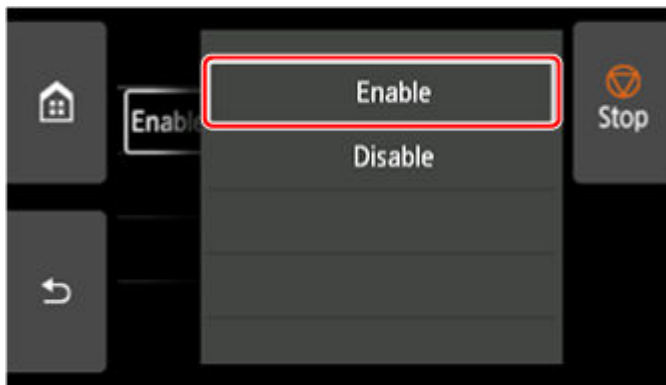

9. Tap  on the left side of the screen.



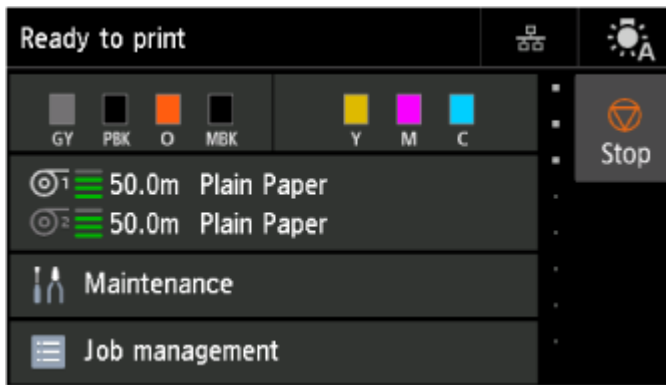

The network connection setup is now complete.



Once connection is complete,  appears on the screen.

If performing setup with software, return to the software and proceed with the installation.

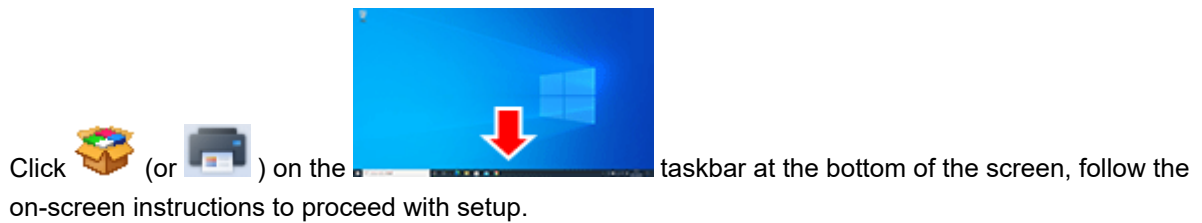

Windows

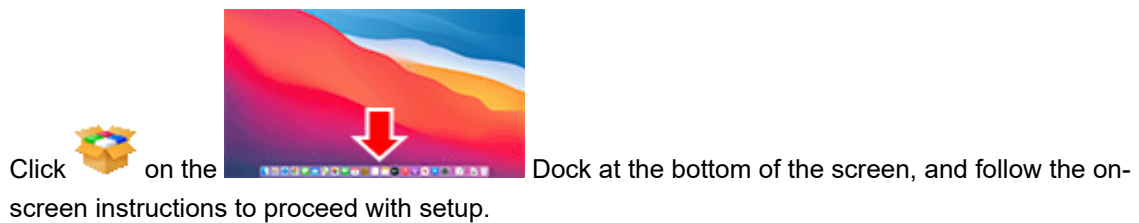

Click  (or ) on the  taskbar at the bottom of the screen, follow the on-screen instructions to proceed with setup.

macOS



Click  on the  Dock at the bottom of the screen, and follow the on-screen instructions to proceed with setup.

USB Connection

Connect the printer to a computer using a USB cable.

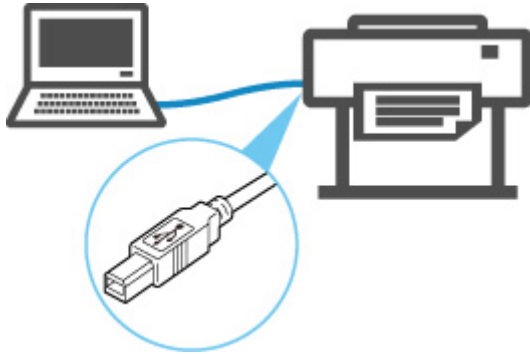

➔ What Is USB Cable?

In USB connection, the printer is connected one-on-one to the computer.

If your computer is connected to LAN, you can use the printer with other devices by enabling the sharing setting on your computer.

➤➤➤ Note

- You can connect the printer to a computer via USB even when the printer is already connected to another one via wired LAN.

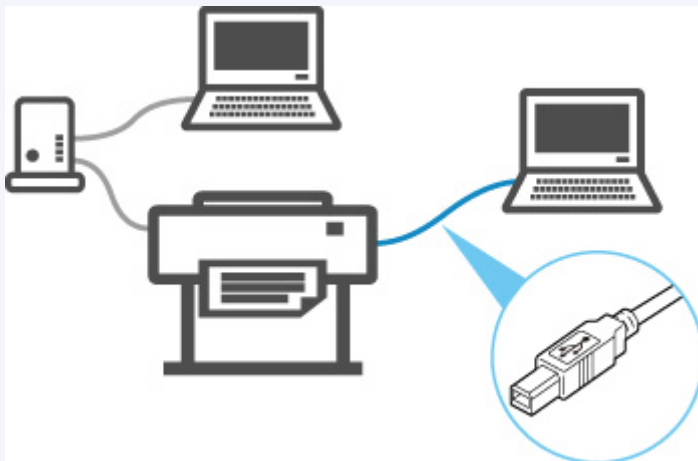

Another Printer Found with Same Name

When the printer is found during setup, other printers with the same name may appear on the results screen.

Select a printer with checking the printer settings against those on detection result screen.

Check the printer's MAC address or serial to select the correct printer from the results.

▶▶ Note

- Serial number may not appear on result screen.

Check the printer's MAC address and serial number by selecting **Printer information > System information**.

➔ [Printer information](#)

Printing Network Settings

Use the operation panel to print the printer's current network settings.

▶▶▶ Important

- The network settings printout contains important information about your network. Handle it with care.

Items to Prepare

When Using Rolls

Plain paper of sufficient length

When Using Sheets

12 sheets of A4 or Letter-sized plain paper

1. Load paper.

- ➔ [Loading Rolls in the Printer](#)
- ➔ [Loading Roll Paper in the Roll Unit](#)
- ➔ [Loading Sheets in the Printer](#)

2. Select **Printer settings** on HOME screen.

3. Select **LAN settings**.

4. Select **Print details**.

5. Select **Yes** on displayed screen.

6. Select **Yes** or **No** on displayed screen.

The printer starts printing network settings information.

▶▶▶ Note

- You can also print the printer's network settings. Select the  **Printer settings > Test print > Print LAN details > Yes > Yes**.

Printed network settings information can also be viewed from the operation panel or remote UI.

- ➔ [LAN settings](#)
- ➔ [Menu Structure](#)
- ➔ [Changeable Setting Items Using Remote UI](#)

Countermeasures against Unauthorized Access

This section describes countermeasures against an unauthorized access to the printer from outside. When you use the printer via a network or you are an administrator, we recommend you read this section before using the printer.

Four countermeasures below can be helpful against an unauthorized access.

- ➔ [Specify a Private IP Address](#)
- ➔ [Restrict Communication Using Firewall or Wi-Fi Router](#)
- ➔ [Specify a Password for the Printer](#)
- ➔ [Apply higher security level for Wi-Fi connection](#)

▶▶▶ Note

- As the setting procedure described below is an example, it may be different from that of your printer. For details, refer to your printer's manual.

Specify a Private IP Address

An IP address is a numeric label assigned to each device on the network. There are two types of IP address. One is used for internet connection ("global IP address"), and the other is used for a local area network such as an inhouse LAN ("private IP address").

If a global IP address is specified for the printer, many and unspecified users on internet can access to the printer. As a result, you will face an increased risk of information leakage caused by an unauthorized access from outside. On the other hand, if a private IP address is specified for the printer, users who can access to the printer are confined to those on a local area network such as an inhouse LAN. Therefore, we recommend you specify a private IP address for the printer.

The range of addresses used as a private IP address is shown below. Make sure whether a private IP address is specified for your printer.

Range of private IP address

- 10.0.0.0 to 10.255.255.255
- 172.16.0.0 to 172.31.255.255
- 192.168.0.0 to 192.168.255.255

Procedure to check the IP address

Select **Setup > Device settings > LAN settings** on your printer to select a network connection method and check the IP address. For the procedure to check and specify the IP address, refer to your printer's manual.

▶▶▶ Note

- Establishing an environment to protect an access from outside using a firewall can reduce a risk of an unauthorized access even though a global IP address is specified for your printer.

Restrict Communication Using Firewall or Wi-Fi Router

Firewall is a system which prevents an unauthorized access from an external network user to protect an inhouse network against attack or intrusion.

Firewall enables your network to be protected against an unauthorized access by restricting a communication from the specific external IP address which seems to have a risk.

A home use Wi-Fi router has a similar function. Be careful when you change the settings.

Specify a Password for the Printer

Even if a malicious third party accesses to your printer by any chance, you can reduce a risk of information leakage drastically by specifying a password to protect various information on your printer.

In addition, though the printer can be protected by specifying a password, it is important to manage the specified password for security. Manage your password referring to the four points below. For details, refer to your printer's manual.

- Be sure to change the default password.
- Change the password periodically.
- Do not use a password easy to guess for a third party.
- Do not tell a third party about the specified password casually.

▶▶ Note

- A password is not specified for some printers at the time of purchase. In this case, specify the password for the printer.
- A password cannot be specified for some printers.

Password management using Remote UI (User Interface)

Remote UI is a software to access to the printer via a network by using a web browser. You can check the printer status or settings on Remote UI, which allows you to perform operations almost the same as those you can on the operation panel of the printer.

Entering the printer's IP address or host name on the web browser displays the portal page of Remote UI.

For the procedure to start up or operations of Remote UI, refer to your printer's manual.

▶▶▶ Important

- Do not access to a website while you are using Remote UI on the web browser.

In addition, be sure to close the web browser when you leave your seat before you finish performing settings, or when you have finished performing settings.

Apply higher security level for Wi-Fi connection

When you use the printer via Wi-Fi, we recommend you apply a security method with higher security level (e.g. WPA/WPA2).

For more on operations, refer to your printer's manual.

Network Status and Troubleshooting

Check the network status referring to LAN setting information on the touch screen.

➔ [Printing Network Settings](#)

Network Status	What to Do
<p>Connected normally.</p> <p>If you are unable to print, see 1 on What to Do.</p>	<p>1. If you are unable to print, check the items below:</p> <ul style="list-style-type: none"> • whether the computer is connected to Wi-Fi • whether the firewall of your security software is enabled • whether a privacy separator, SSID separator, or Network separation function is enabled on your wireless router <p style="padding-left: 40px;">If one of the above is enabled, disable it before setup.</p> <ul style="list-style-type: none"> • whether the network name (SSID) of the printer matches that of the router to connect <p>2. To change the network connection method (wired/wireless), change it on the printer's network setting screen.</p>
<p>Wi-Fi is disabled on the printer.</p>	<p>Perform printer setup following the instructions of the manual.</p>
<p>Wired LAN connection is disabled.</p>	<ul style="list-style-type: none"> • Make sure the printer is connected to the router with the LAN cable. <p style="padding-left: 40px;">If the LAN cable is loose, connect the cable properly.</p> <p style="padding-left: 40px;">If the LAN cable is connected to the WAN side of the router, connect the cable to the LAN side of the router.</p> <ul style="list-style-type: none"> • Make sure the network devices (e.g. hub or router) are turned on.
<p>IP address is not assigned.</p>	<ul style="list-style-type: none"> • If you specify the printer's IP address automatically, enable DHCP on the router. • If you specify the printer's IP address manually, the address is disabled because it is out of the valid range. You specified (0.0.0.0) as the IP address, for example. <p style="padding-left: 40px;">Specify the valid IP address.</p>
<p>The default gateway is not specified.</p>	<p>Check the items below to communicate by hopping routers (e.g. using a cloud application).</p> <ul style="list-style-type: none"> • Make sure the device specified as the default gateway is turned on. • Specify the default gateway address correctly.
<p>Cannot connect to the specified network.</p>	<p>Check the status of the printer, network devices (e.g. wireless router), or smartphone/tablet.</p> <ul style="list-style-type: none"> • If they are turned off, turn them on. • Make sure wireless signal is strong. <p style="padding-left: 40px;">Monitor signal status and move the printer and wireless router as necessary.</p> <ul style="list-style-type: none"> • The security key specified for the wireless router may not match that you entered. <p style="padding-left: 40px;">The security key is case-sensitive.</p> <p style="padding-left: 40px;">Enter the correct security key.</p>
<p>Make sure wireless signal is strong.</p>	<ul style="list-style-type: none"> • Make sure the printer is not placed too far away from the wireless router. • Monitor signal status and move the printer and wireless router as necessary.

<p>The number of connected clients reaches the upper limit.</p>	<ul style="list-style-type: none"> • Wireless Direct does not allow more than 5 devices to be connected. <p>If you add a device to connect, disconnect a device you do not use before adding the device.</p>
<p>The signal to noise ratio (S/N ratio) is low.</p>	<ul style="list-style-type: none"> • There is a lot of noise from other devices. <p>Move the printer apart from other devices.</p>
<p>A link local address is assigned.</p>	<ul style="list-style-type: none"> • Perform printer setup again. • The security key specified for the wireless router may not match that you entered. <p>The security key is case-sensitive.</p> <p>Enter the correct security key.</p>
<p>The specified network name (SSID) is left default value.</p>	<p>The network name (SSID) is not specified.</p> <p>Enter the network name (SSID) specified for the destination.</p>

Sharing the Printer on a Network (macOS)

When multiple computers are being used in the network environment, you can share the printer connected to one computer with the other computers.

Before carrying out the setup for printer sharing, select **Network** from **System Settings**, and check whether the network settings have been set.

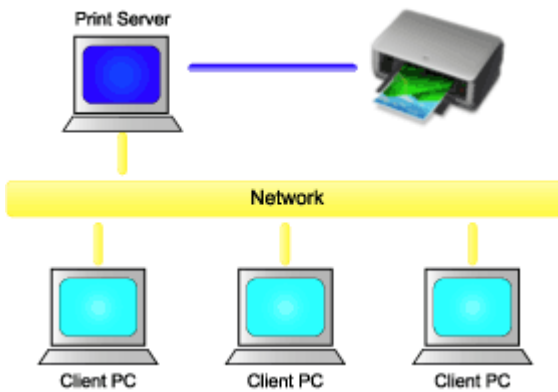

This section describes the procedure for sharing a printer among Mac.

- [Settings on Print Server](#)

This section describes how to set up a computer that connects with this printer.

- [Settings on Client PC](#)

This section describes the procedure for setting a computer that uses this printer through a network. When you execute print, the data is sent to the printer through the print server system.

Related Topic

- ➔ [Restrictions on Printer Sharing](#)

Settings on Print Server

When you use the printer on a network, set up the printer driver for sharing on the print server system.

The procedure for setting up the print server systems is as follows:

1. [Install the printer driver](#) on the print server system

2. Check that the printer to be used has been added

Open **System Settings**, and select **Printers & Scanners**.

The printer list displays the printers that are connected to the computer.

3. Set sharing

Turn on **Share this printer on the network**.

»» Note

- Depending on the environment you are using, a message prompting you to restart the computer may be displayed. To complete the installation properly, restart the computer.

The setup on the print server system is complete. Next, set up the client systems.

Settings on Client PC

After setting up the print server system, set up the client system.

The procedure for setting up the client systems is as follows:

1. [Install the printer driver](#) on the client systems

2. Display the printer list

Open **System Settings**, and select **Printers & Scanners**.

Click **Add Printer, Scanner or Fax...** to display the printer list.

3. Add a printer to be shared

Select a shared printer displayed in the printer list, and then click **Add**.

The setup on the client systems is now completed.

▶▶▶ Note

- The print procedures are the same as when the computer is connected directly to the printer with a USB cable.
At the Page Setup dialog, select the printer that is connected to the print server to be used.

Restrictions on Printer Sharing

These are restrictions that apply when you are using a printer in a network environment.

- Install the same version of the printer driver in the print server system and the client systems. You can download the latest printer driver from our web site.
- Use printer sharing with users who have the administrator privilege.
- Depending on how the computer is connected with the printer, the computer may not be able to access the function information that was set on the printer and display the correct settings.
- Media information on the printer driver cannot be changed when using a client machine.
- When using on the client side, it is not possible to change the roll unit option settings.
- When using on the client side, you cannot configure **Accounting** settings.
- When using on the client side, you cannot use Remote UI.

Maintenance

► Adjustments for Better Print Quality

- Checking for Nozzle Clogging
- Cleaning the Print Head
- Adjustment to Straighten Lines and Align Colors
- Adjusting Different Colored Horizontal Streaks
- Fine-Tuning Paper Feed Amount
- Adjusting Line Length
- Troubleshooting Paper Abrasion and Blurry Images
- Color Management

► Replacing Consumables

- Checking the Ink Tank Model Number
- Replacing Ink Tanks
- Checking Ink Level
- Replacing the Print Head
- Replacing the Maintenance Cartridge
- Checking the Remaining Maintenance Cartridge Capacity
- Replacing the Cutter Blade

► Cleaning the Printer

- Cleaning the Printer Exterior
- Cleaning Inside the Top Cover
- Cleaning the Roll Unit
- Cleaning the Internal Light

► Performing Maintenance Functions from Your Computer (Windows)

- Cleaning the Print Heads
- Printing a Nozzle Check Pattern

► Performing Maintenance Functions from Your Computer (macOS)

- Opening Remote UI for Maintenance
- Cleaning the Print Heads
- Printing a Nozzle Check Pattern

➤ **Other Maintenance**

- Preparing to Transfer the Printer
- Reinstalling the Printer
- Firmware update

Adjustments for Better Print Quality

- **Checking for Nozzle Clogging**
- **Cleaning the Print Head**
- **Adjustment to Straighten Lines and Align Colors**
 - Automatic Adjustment to Straighten Lines and Align Colors
 - Manual Adjustment to Straighten Lines and Align Colors
- **Adjusting Different Colored Horizontal Streaks**
 - Automatically Adjusting Different Colored Horizontal Streaks
 - Manually Adjusting Different Colored Horizontal Streaks
- **Fine-Tuning Paper Feed Amount**
- **Adjusting Line Length**
- **Troubleshooting Paper Abrasion and Blurry Images**
 - Changing the Print Head Height
 - Adjusting Vacuum Strength
- **Color Management**
 - Managing Colors
 - Performing Color Calibration
 - Adjustment Types of Color Calibration

Checking for Nozzle Clogging

If printing is faint or affected by banding in different colors, make sure the print head nozzles are clear by printing a test pattern to check the nozzles.

▶▶▶ Note

- You can also check for nozzle clogging from your computer.
 - ➔ Printing a Nozzle Check Pattern (Windows)
 - ➔ [Printing a Nozzle Check Pattern](#) (macOS)
- By default, nozzles are checked at fixed intervals.
 - ➔ [Auto maintenance settings](#)

Paper to Prepare

When using rolls

An unused roll at least 10.00 in. (254.0 mm) wide

When using sheets

1 sheet of unused paper of at least A4/Letter size

1. Load paper.

- ➔ [Loading Rolls in the Printer](#)
- ➔ [Loading Roll Paper in the Roll Unit](#)
- ➔ [Loading Sheets in the Printer](#)

2. Select Maintenance on HOME screen.

3. Select **Nozzle Check**.

A confirmation message appears.

4. Select **Yes**.

The printer now prints a test pattern for checking the nozzles.

5. Check the printing results.

If the horizontal lines are not faint or incomplete, the nozzles are clear.

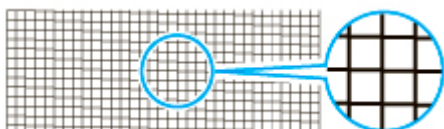

If some sections of the horizontal lines are faint or incomplete, the nozzles for those colors are clogged.

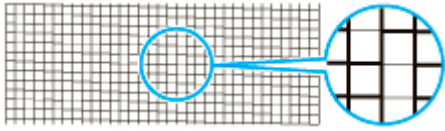

If horizontal lines are faint or incomplete, execute print head cleaning.

➡ [Cleaning the Print Head](#)

Cleaning the Print Head

If printing is faint, cleaning the print head may improve results.

▶▶▶ Note

- You can also clean the print head from your computer.
 - ➔ [Cleaning the Print Heads \(Windows\)](#)
 - ➔ [Cleaning the Print Heads \(macOS\)](#)

Choose one of three print head cleaning modes (**Cleaning**, **Deep Cleaning**, or **System Cleaning**), depending on the problem to resolve.

- **Cleaning**

Use this mode if printing is faint or contains foreign substances. This method of cleaning consumes the least amount of ink.

It takes about 4 minutes.

- **Deep Cleaning**

Use this mode if no ink is ejected at all or if **Cleaning** does not solve the problem.

It takes about 4 minutes.

- **System Cleaning**

Use this mode if printing is not improved after **Deep Cleaning**. **System Cleaning** consumes a very large amount of ink. Performing this frequently consumes the ink faster. Perform this only when needed.

It takes about 13 minutes.

▶▶▶ Important

- Do not remove the maintenance cartridge or ink tanks during **Cleaning**, **Deep Cleaning**, or **System Cleaning**.

Ink may leak or an error may occur.
- If printing is not improved after **System Cleaning**, the print head may be at the end of its service life. Contact your Canon dealer for assistance.

▶▶▶ Note

- Check the nozzle check pattern and select an ink group for which to perform cleaning as needed. You can clean all print head or select the pattern below to clean the print head with a clogged nozzle.

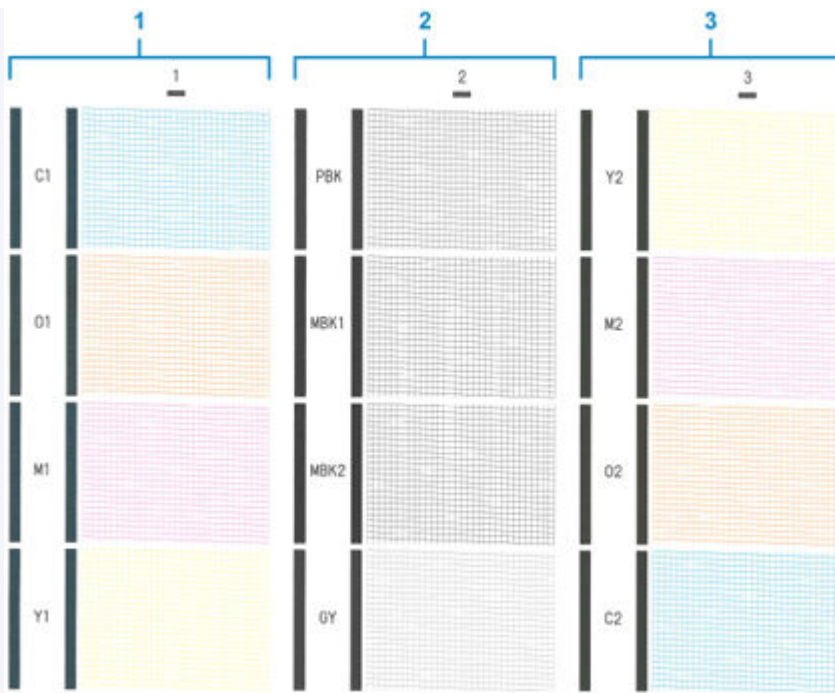

- By default, nozzles are checked at fixed intervals.

➔ [Auto maintenance settings](#)

Perform cleaning as follows.



1. Select **Maintenance** on HOME screen.
2. Select **Print Head Cleaning**.
3. Select **Cleaning**, **Deep Cleaning**, or **System Cleaning**.
4. Select ink group to be cleaned.
 - **All colors**
 - **Pattern 1:** C1 / O1 / M1 / Y1
 - **Pattern 2:** PBK / MBK1 / MBK2 / GY
 - **Pattern 3:** Y2 / M2 / O2 / C2

A confirmation message appears.

5. Select **Yes**.

Head cleaning is now executed.

6. Print a test pattern to check the nozzles and determine whether cleaning has cleared the nozzles.

➔ [Checking for Nozzle Clogging](#)

Adjustment to Straighten Lines and Align Colors

- **Automatic Adjustment to Straighten Lines and Align Colors**
- **Manual Adjustment to Straighten Lines and Align Colors**

Automatic Adjustment to Straighten Lines and Align Colors

If printed vertical lines are warped or colors are out of alignment, execute **Print Head Alignment** and adjust the print head position.

Choose from **Auto (standard)** or **Auto (advanced)** for automatically adjusting the print head.

Minor warping and misaligned colors can usually be improved by executing **Auto (standard)**. If there is no improvement, perform **Auto (advanced)** or **Manual**.

➔ [Manual Adjustment to Straighten Lines and Align Colors](#)

When you execute **Auto (standard)** or **Auto (advanced)**, the adjustment pattern is printed, and the print head position is adjusted based on the printing result automatically.



Important

- Because the results of adjustment vary depending on the type of paper used for adjustment, use the same type of paper as you will use for printing.
- This function is not available for paper with high transparency.

Note

- After print head replacement, we recommend executing **Print Head Alignment**. When **Print pattern after new head** is set to **ON**, print head position adjustment is automatically executed after print head replacement.
- To change the paper type or for more beautiful color borders, perform **Auto (standard)**.
- To ensure clear quality and when replacing the print head, perform **Auto (advanced)** to fine-tune the position between nozzles and colors. To ensure high-quality printing, we recommend that you execute **Auto (advanced)**.
- If adjustment is not possible as expected using special paper, try another type of paper or try **Manual** adjustment.

➔ [Manual Adjustment to Straighten Lines and Align Colors](#)

Paper to Prepare

When using rolls

An unused roll at least 10.00 in. (254.0 mm) wide

When using sheets

Auto (standard): 3 sheets of unused paper, A4/Letter size or larger (or 1 sheet when using A2 or larger)

Auto (advanced): 5 sheets of unused paper, A4/Letter size or larger (or 1 sheet when using A2 or larger)

Perform adjustment as follows.

1. Load paper.

- ➔ [Loading Rolls in the Printer](#)
- ➔ [Loading Roll Paper in the Roll Unit](#)
- ➔ [Loading Sheets in the Printer](#)

▶▶▶ **Important**

- Always make sure the loaded paper matches the type of paper specified on the printer. Adjustment cannot be completed correctly unless the loaded paper matches the settings.



2. Select **Maintenance** on HOME screen.

3. Select **Print Head Alignment**.

4. Select **Auto (standard)** or **Auto (advanced)**.

A confirmation message appears.

5. Select **Yes**.

The paper source setting screen appears.

6. Select **Roll paper 1**, **Roll paper 2** or **Manual**.

A test pattern is printed for adjustment.

▶▶▶ **Note**

- If you are printing on cut paper smaller than A2 size, a confirmation message prompting you to continue printing appears after the first sheet is printed. Select **Yes** and follow the instructions on the touch screen.

Manual Adjustment to Straighten Lines and Align Colors

If printed vertical lines are warped or colors are out of alignment, execute **Print Head Alignment** and adjust the print head position.

Normally, execute **Auto (standard)**.

➔ [Automatic Adjustment to Straighten Lines and Align Colors](#)

However, when printing on special paper or if printing is not improved after **Auto (advanced)**, try **Manual**.

Manual adjustment requires you to examine the printed test pattern and enter an adjustment value.



Important

- Because the results of adjustment vary depending on the type of paper used for adjustment, use the same type of paper as you will use for printing.

Paper to Prepare

When using rolls

An unused roll at least 10.00 in. (254.0 mm) wide

When using sheets

3 sheets of unused paper, A4/Letter size or larger (or a sheet when using A2 or larger)

Perform adjustment as follows.

1. Load paper.

- ➔ [Loading Rolls in the Printer](#)
- ➔ [Loading Roll Paper in the Roll Unit](#)
- ➔ [Loading Sheets in the Printer](#)

Important

- Always make sure the loaded paper matches the type of paper specified on the printer. Adjustment cannot be completed correctly unless the loaded paper matches the settings.

2. Select **Maintenance** on HOME screen.

3. Select **Print Head Alignment**.

4. Select **Manual**.

A confirmation message appears.

►►► **Note**

- If you do not perform **Auto (advanced)**, a confirmation message prompting you to perform **Auto (advanced)** appears. In this case, select **Yes** and perform **Auto (advanced)**.

5. Select Yes.

The paper source setting screen appears.

6. Select Roll paper 1, Roll paper 2 or Manual.

A test pattern is printed for adjustment.

7. Select D-1.

8. Examine adjustment test pattern D-1 and select the number with straight lines.

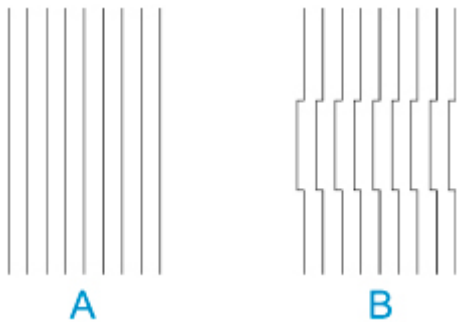

A: Example with straight lines

B: Example with misaligned lines

►►► **Note**

- If two patterns seem equally good and you cannot decide which one is better, choose an intermediate value. For example, choose 11 if you cannot decide whether pattern 10 or 12 is better.

9. Repeat steps 7-8 to specify adjustment values for D-2 and other remaining patterns.

Specify all the items displayed on the touch screen.

10. Select OK.

The adjustment value is now registered, and adjustment is complete.

Adjusting Different Colored Horizontal Streaks

- **Automatically Adjusting Different Colored Horizontal Streaks**
- **Manually Adjusting Different Colored Horizontal Streaks**

Automatically Adjusting Different Colored Horizontal Streaks

If printed images are affected by banding in different colors across the sheet, execute **Adjust print quality** for automatic adjustment of the paper feed amount.

The printer prints and reads a test pattern for automatic adjustment of the feed amount.

▶▶▶ Important

- When using highly transparent media, use manual adjustment.
 - ➔ [Manually Adjusting Different Colored Horizontal Streaks](#)

▶▶▶ Note

- We recommend executing the adjustment if you have changed the paper type or paper size.
- Always check the **Set priority** values.
 - ➔ [Paper feed adjustment](#)
- If additional fine-tuning is necessary, execute **Paper feed fine adjustment**.
 - ➔ [Fine-Tuning Paper Feed Amount](#)
- Use **Adjust feed length** to ensure that lines in CAD drawings are printed at exactly the right length.
 - ➔ [Adjusting Line Length](#)
- This may take some time, depending on the type of paper.

Items to Prepare

When Using Rolls

An unused roll at least 10.00 in. (254.0 mm) wide

When Using Sheets

One sheet of unused paper of at least A4/Letter size

Follow the procedure below to adjust.

1. Load paper.
 - ➔ [Loading Rolls in the Printer](#)
 - ➔ [Loading Roll Paper in the Roll Unit](#)
 - ➔ [Loading Sheets in the Printer](#)
2. Select  **Maintenance** on HOME screen.
3. Select **Paper feed adjustment**.
4. Select **Adjust print quality**.
5. Select **Auto**.
6. Select **Roll paper 1**, **Roll paper 2** or **Manual**.

A test pattern is printed for adjustment and adjustment is finished.

Manually Adjusting Different Colored Horizontal Streaks

If printed images are affected by banding in different colors, execute **Adjust print quality** for adjustment of the paper feed amount.

Use manual adjustment with highly transparent media.

Manual adjustment requires you to enter an adjustment value after a test pattern is printed.

▶▶▶ Note

- We recommend executing the adjustment if you have changed the paper type or paper size.
- Always check the **Set priority** values.
 - ➔ [Paper feed adjustment](#)
- If additional fine-tuning is necessary, execute **Paper feed fine adjustment**.
 - ➔ [Fine-Tuning Paper Feed Amount](#)
- Use **Adjust feed length** to ensure that lines in CAD drawings are printed at exactly the right length.
 - ➔ [Adjusting Line Length](#)

Items to Prepare

When Using Rolls

An unused roll at least 10.00 in. (254.0 mm) wide

When Using Sheets

Two sheets of unused paper of at least A4/Letter size

Follow the procedure below to adjust.

1. Load paper.

- ➔ [Loading Rolls in the Printer](#)
- ➔ [Loading Roll Paper in the Roll Unit](#)
- ➔ [Loading Sheets in the Printer](#)

▶▶▶ Important

- Always make sure the loaded paper matches the type of paper specified. Adjustment cannot be completed correctly unless the loaded paper matches the settings.



2. Select **Maintenance** on HOME screen.

3. Select **Paper feed adjustment**.

4. Select **Adjust print quality**.

5. Select **Manual**.

6. Select **Roll paper 1**, **Roll paper 2** or **Manual**.

Test pattern A is printed for manual adjustment.

▶▶▶ Note

- When printing on sheets, follow the instructions on the screen and remove the sheet.

7. Examine test pattern A for adjustment.

Determine pattern in which banding is least noticeable.

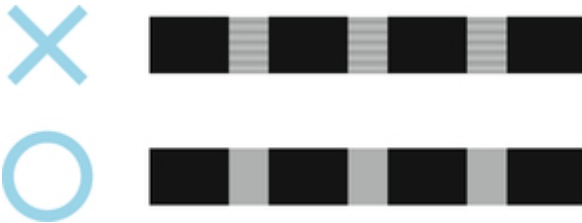

▶▶▶ Note

- If banding seems least noticeable in two patterns but you cannot decide which one is better, choose an intermediate value. For example, choose 11 if you cannot decide whether pattern 10 or 12 is better.

8. Select number you decided.

Test pattern B is printed for manual adjustment.

▶▶▶ Note

- If you printed test pattern A on a sheet, follow the instructions on the screen and use another sheet of the same type of paper. Additionally, after test pattern B is printed, follow the instructions on the screen and remove the sheet.

9. Examine test pattern B for adjustment. Determine pattern in which banding is least noticeable.

10. Select number you decided.

The adjustment value is now registered, and adjustment is complete.

Fine-Tuning Paper Feed Amount

If the contrast is uneven or banding in different colors appears at 1.2 in. (30 mm) intervals in printed documents, try executing **Paper feed fine adjustment** during printing to fine-tune the feed amount.

▶▶▶ Note

- The **Paper feed fine adjustment** menu is only displayed during printing. Additionally, it is displayed when you have selected **Auto** or **Prioritize print quality** in **Set priority** in **Paper feed adjustment**.
- Always execute **Adjust print quality** before **Paper feed fine adjustment**. Once you execute **Adjust print quality**, the **Paper feed fine adjustment** value will revert to 0.
 - ➔ [Automatically Adjusting Different Colored Horizontal Streaks](#)
 - ➔ [Manually Adjusting Different Colored Horizontal Streaks](#)

Follow the procedure below to adjust.

1. Select  **Maintenance** on HOME screen during printing.
2. Select **Paper feed fine adjustment**.
3. Select value.

At this time, if banding in dark colors appears, select a setting value in the range 1 to 5, and if banding in light colors appears, select a setting value in the range -1 to -5.

Adjusting Line Length

To ensure that lines in CAD drawings are printed at exactly the right length, use **Adjust feed length** to adjust the amount that paper is advanced.

There are two options in **Adjust feed length** : **Print alignment pattern** and **Change adjustment values**.

▶▶▶ Note

- We recommend executing the adjustment if you have changed the paper type or paper size.
- Always check the **Set priority** values before adjustment.

➔ [Paper feed adjustment](#)

Items to Prepare

When Using Rolls

- An unused roll at least 10.00 in. (254.0 mm) wide
- High-precision ruler

When Using Sheets

- One sheet of unused paper of at least A4/Letter size
- High-precision ruler

Follow the procedure below to adjust.

1. Load paper.

- ➔ [Loading Rolls in the Printer](#)
- ➔ [Loading Roll Paper in the Roll Unit](#)
- ➔ [Loading Sheets in the Printer](#)

▶▶▶ Important

- Always make sure the loaded paper matches the type of paper specified. Adjustment cannot be completed correctly unless the loaded paper matches the settings.



2. Select **Maintenance** on HOME screen.

3. Select **Paper feed adjustment**.

4. Select **Adjust feed length**.

5. Select **Print alignment pattern** or **Change adjustment values**.

- If you select **Print alignment pattern**:

The test pattern is printed for you to measure the scale and calculate the discrepancy.

The scale bar prints "Millimeter" in 50 mm increments and "Inch" in 1-inch increments.



- If you select **Change adjustment values:**

No test pattern is printed. Instead, you will measure a document already printed to determine the discrepancy.

6. Select amount of discrepancy.

If the scale is shorter than the actual size, use a positive setting value. If it is longer, use a negative value. The feed amount can be adjusted in 0.02% increments.

Troubleshooting Paper Abrasion and Blurry Images

- **Changing the Print Head Height**
- **Adjusting Vacuum Strength**

Changing the Print Head Height

The print head height setting affects printing quality.

Specifying a low print head height makes images clearer and enhances printing quality but may cause paper to rub against the print head.

On the other hand, specifying a high print head height will prevent paper from rubbing against the print head but may reduce the printing quality.

►►► Important

- Paper rubbing against or becoming caught on the print head may jam or result in printed documents that are soiled.

►►► Note

- Raise or lower print head, depending on nature of the problem.
 - ➔ [Paper rubs against the Print Head](#)
 - ➔ [The edges of the paper are dirty](#)
 - ➔ [Image edges are blurred or white banding occurs](#)

1. Select paper setting display area on HOME screen.

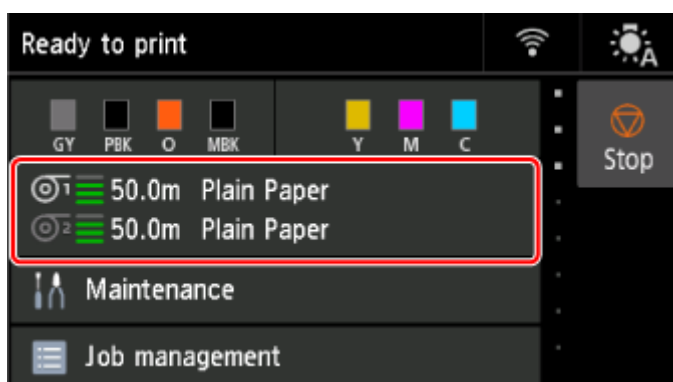

2. Select paper source.

3. Select **Paper settings**.

4. Select **Advanced**.

5. Select **Head height**.

6. Select a setting value.

►►► Note

- When set to **Auto**, before printing, the printer automatically adjusts the print head height to the level optimal for the ambient temperature and humidity. You can check the setting for the previous print job in **Values applied with auto settings**.

➡ [Printer information](#)

- When the setting other than **Auto** is selected, the setting selected during this procedure is applied.
- Depending on the type of paper, some setting values may not be available.

Adjusting Vacuum Strength

When printing on heavyweight paper or paper that curls or wrinkles easily, if the Print head rubs against paper, adjusting the level of suction against paper on the platen may improve results.

►► Important

- Paper rubbing against or becoming caught on the Print head may jam or result in printed documents that are soiled.

1. Select paper setting display area on HOME screen.

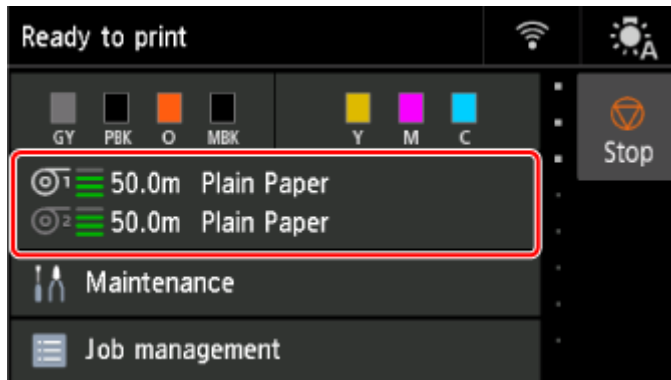

2. Select paper source.
3. Select **Paper settings**.
4. Select **Advanced**.
5. Select **Transport unit vacuum strength**.
6. Select vacuum strength.

Color Management

- **Managing Colors**
- **Performing Color Calibration**
- **Adjustment Types of Color Calibration**

Managing Colors

Color management (color calibration) corrects for variations in color tones due to differences between printers and aging, and obtains continuously stable corrected color tones.

The color tones of this printer can be corrected by executing color calibration.

If you have multiple printers, you can make the color tones of the printers the same by executing color calibration on each of the printers.

▶▶▶ Note

- Even though the adjustment value of color calibration is applied, the color tones may not be stable with the following setting.
 - Printing quality: **Fast**
 - Media type: **CAD Clear Film/PlainP(Instant-dry)**

Execute Color Calibration

Executing color calibration improves color consistency by compensating for slight differences in how color appears due to individual variations or aging among the printers.

You can use the operation panel to enable or disable the color calibration adjustment values, view the calibration status, and configure notifications when color calibration needs to be executed.

You can also execute color calibration from Device Management Console.

See the following for details.

➔ [Device Management Console Guide](#)

Checking When to Execute Color Calibration

You can use the progress bar on the computer screen to determine when to execute color calibration.

Use Device Management Console to view when to execute color calibration.

See the following for details.

➔ [Device Management Console Guide](#)

Checking Color Calibration Execution Logs

You can check the paper name and the date and time which color calibration was executed for each media type.

Use Device Management Console to view color calibration execution logs.

See the following for details.

➔ [Device Management Console Guide](#)

Centrally Managing Multiple Printers

You can view the status of multiple network- and USB-connected printers.

You can also set up email notification if printer warnings or errors occur.

Use Device Management Console to manage the printers.

See the following for details.

➔ [Device Management Console Guide](#)

Using Paper Other Than Canon Genuine Paper

To execute color calibration for paper other than Canon genuine paper, you must create and register dedicated media information.

To register this media information, use Media Configuration Tool.

See the following for details.

➔ [Media Configuration Tool Guide](#)

Performing Color Calibration

Color calibration improves color consistency by compensating for slight differences in how color appears when printing due to individual variations or aging among the printers.

Executing color calibration will print a test pattern (built into the printer) that is then read automatically by the printer.

By this operation, calibration adjustment values reflecting the print result of the test pattern are set automatically.

►► Important

- To increase the color stability precision when executing color calibration, maintain a constant temperature and humidity environment each time within the range of temperatures of 59 to 86°F (15 to 30°C) and within the range of humidities of 40 to 60%.

Executing color calibration under various temperature and humidity conditions may prevent the printer from making the correct adjustments.

- Before color calibration, ensure the printer is not exposed to direct sunlight or other strong sources of light.

If the printer is exposed to strong sources of light, correct adjustment may not be possible.

Recommend Timing for Color Calibration

We recommend color calibration in the following situations.

- After initial printer installation
- After print head replacement
- If colors seem different from before, despite using the same printing environment, under the same conditions
- To print with colors aligned from multiple printers
- When the execution guide is displayed

Executing Color Calibration

Paper size that can be used for color calibration

When using rolls

Roll at least 10.00 in. (254.0 mm) wide

When using sheets

Sheet of A4/Letter size or larger

Execute color calibration using the following procedure.

1. You can confirm whether the paper to be loaded can be used in color calibration.
 - ➡ Paper Information List
2. Load paper.

- ➔ [Loading Rolls in the Printer](#)
- ➔ [Loading Roll Paper in the Roll Unit](#)
- ➔ [Loading Sheets in the Printer](#)



3. Select **Maintenance** on HOME screen.

4. Select **Color calibration**.

5. Select **Auto adjust**.

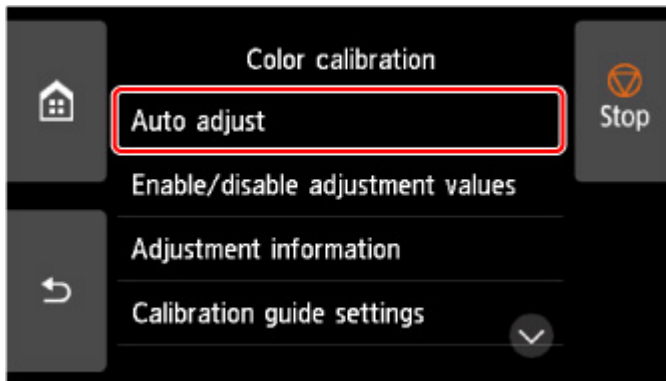

A confirmation message appears.

➤➤➤ **Note**

- For details about menu items other than **Auto adjust**, see [Other Menu Items](#).

6. Select **Yes**.

The paper source setting screen appears.

7. Select **Roll paper 1**, **Roll paper 2** or **Manual**.

After the paper is confirmed, and color calibration is executed, the calibration adjustment value is set automatically.

Other Menu Items

• **Enable/disable adjustment values**

You can select whether to apply the calibration adjustment value when printing.

However, for settings that differ from **Calibration Value** of the printer driver, the values specified in the printer driver take priority.

• **Adjustment information**

You can confirm the calibration adjustment date/time currently applied and the media type used.

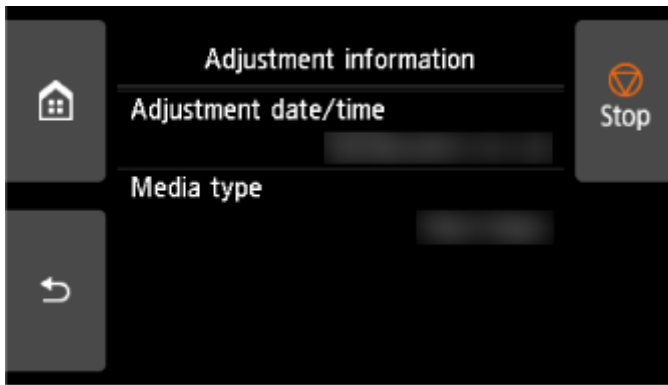

- **Calibration guide settings**

You can select whether to display a message asking to execute color calibration on the touch screen in the following situations.

- When a new print head has been installed
- When a certain amount of printing has been executed after color calibration is executed
- When the data of color calibration has been initialized

- **Reset adjustment values**

Clear the color calibration adjustment value and the adjustment information.

Adjustment Types of Color Calibration

Adjustment Types of Color Calibration

Color calibration allows you to adjust colors for each media type.

There are two adjustment types: common calibration and unique calibration. The appropriate type depends on the media type being used.

For details on whether or not color calibration can be executed and the adjustment types for various types of paper, see Paper Information List.

Features

Common Calibration

When you perform color calibration on paper using common calibration, the results are also applied to any other media types which have not yet been calibrated.

This allows you to use multiple media types quickly because it is not necessary to execute color calibration for each media type.

- If color calibration is executed on a media type categorized as common calibration, new common calibration adjustment values are set.
 - New common calibration adjustment values are set for paper for which color calibration has not been performed.
 - New common calibration values are not overwritten for media types for which color calibration has already been performed. The current calibration adjustment values take priority.

The common calibration adjustment values apply to all print qualities.

►►► Note

- When common calibration is performed on multiple paper types, different calibration adjustment values are applied to each paper type. We recommend using only one paper type for the common calibration.

Unique Calibration

When you calibrate a media type using unique calibration, only the selected paper is adjusted. Other media types are not affected.

- If color calibration is executed on a media type categorized as unique calibration, new unique calibration adjustment values are set specifically for the paper.

►►► Note

- If color calibration has not been executed, any newly set common calibration values will be applied.

►►► Note

- If the paper being used does not support color calibration, execute color calibration for a media type categorized as common calibration in advance. The common calibration adjustment values even apply to the paper being used.

Example: Execute color calibration with the default settings

The following describes adjusting media types A to D. A, B and D use common calibration, and C uses unique calibration.

- First: Execute color calibration with media type A (categorized as common calibration)

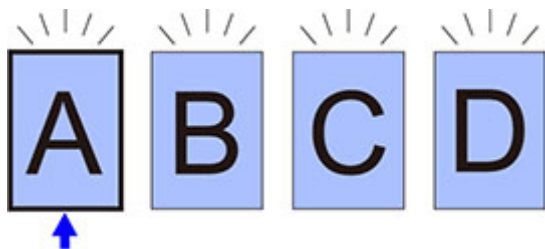

- The calibration adjustment value of media type A is also applied to B to D for which color calibration has not been performed.

- Second: Execute color calibration with media type B (categorized as common calibration)

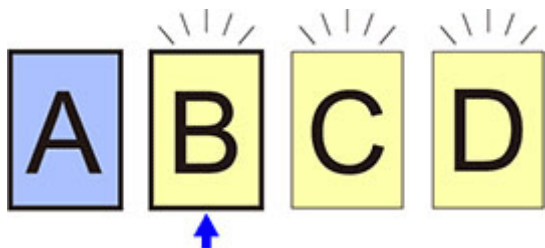

- The calibration adjustment value of media type B is also applied to C and D for which color calibration has not been performed.
- Media type A is not changed from the first directly set adjustment value.

- Third: Execute color calibration with media type C (categorized as unique calibration)

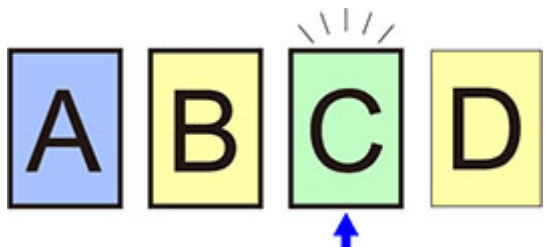

- The calibration adjustment value of media type C is set.
- Media types A, B and D are all unchanged from their current calibration values.

- Fourth: Execute color calibration again with media type A (categorized as common calibration)

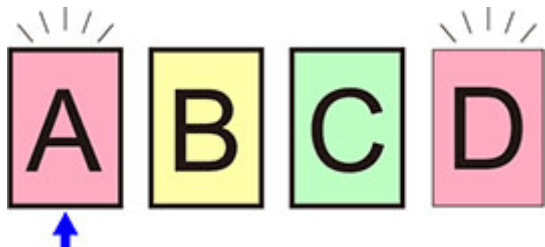

- The calibration adjustment value of media type A is also applied to media type D for which color calibration has not been performed.
- Media types B and C are unchanged from their current calibration values.

▶▶ Note

- You can confirm the currently applied calibration adjustment date and the executed paper type with **Adjustment information** in **Color calibration** on the touch screen menu.

➔ [Performing Color Calibration](#)

Replacing Consumables

- **Checking the Ink Tank Model Number**
- **Replacing Ink Tanks**
- **Checking Ink Level**
- **Replacing the Print Head**
- **Replacing the Maintenance Cartridge**
- **Checking the Remaining Maintenance Cartridge Capacity**
- **Replacing the Cutter Blade**

Checking the Ink Tank Model Number

Checking Using Web Browser

1. Start up Remote UI.

➡ [Start up Remote UI](#)

2. Select **Ink model number**.

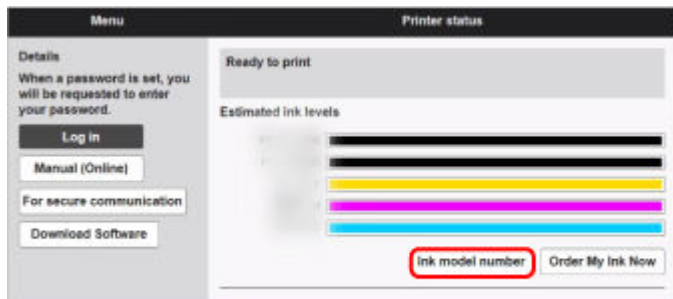

The type and number of inks displayed will vary depending on the printer you are using.

Checking Using Canon IJ Status Monitor (Windows)

1. Start up Canon IJ Status Monitor.

➡ [Canon IJ Status Monitor](#)

2. Select **Estimated ink levels**.
3. Select **Ink Model Number** information.

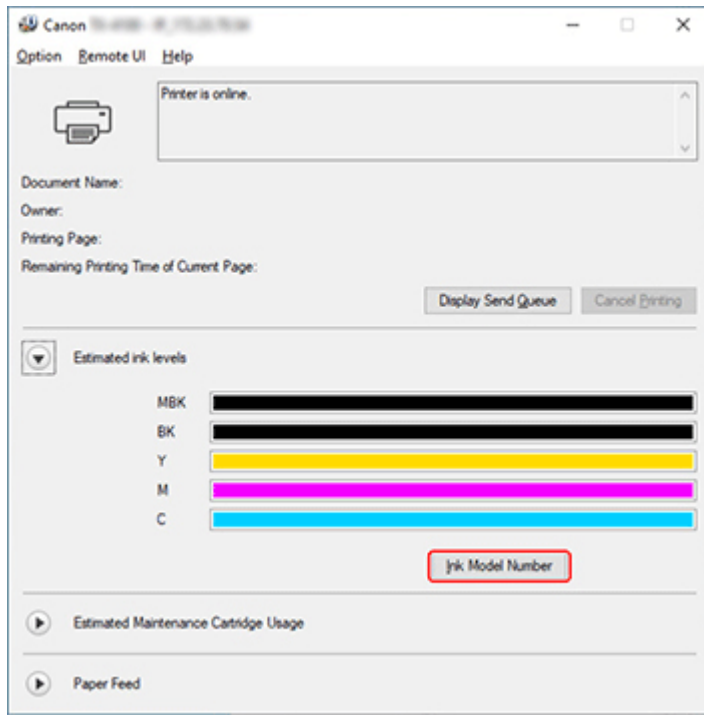

The type and number of inks displayed will vary depending on the printer you are using.

▶▶▶ Note

- For instructions on replacing the ink tanks, see [Replacing Ink Tanks](#).

Replacing Ink Tanks

Compatible Ink Tanks

For details on compatible ink tanks, see [Checking the Ink Tank Model Number](#).

You can replace ink tanks in 5.4 fl oz (160 ml), 11.2 fl oz (330 ml), and 23.7 fl oz (700 ml) capacities.

▶▶▶ Note

- Depending on the color, you can also use an ink tank with a different capacity.

Precautions When Handling Ink Tanks

Take the following precautions when handling ink tanks.

⚠ Caution

- For safety, keep ink tanks out of the reach of children.
- If ink is accidentally ingested, contact a physician immediately.

▶▶▶ Important

- There may be ink around the ink holes of an ink tank you removed. Handle the ink tanks carefully during replacement. The ink may stain clothing.
- Do not install ink tanks used in this printer in another printer. This will prevent correct ink level detection, which may damage the printer or cause other problems.
- We recommend using up an ink tank in the course of printing within six months after breaking the seal. Printing quality may be affected if you use older ink tanks.
- Do not leave the printer without ink tanks installed for extended periods (a month or more). Residual ink may become clogged inside the printer and affect printing quality.

How to Replace an Ink Tank

If a message indicates you should replace an ink tank, check the message details and go to step 2.

1. [Selecting Ink Tank Replacement from Menu](#)
2. Removing Ink Tanks
 - ➔ [Removing ink tank \(5.4 fl oz \(160 ml\) / 11.2 fl oz \(330 ml\)\)](#)
 - ➔ [Removing ink tank \(23.7 fl oz \(700 ml\)\)](#)
3. Loading New Ink Tanks
 - ➔ [Loading ink tank \(5.4 fl oz \(160 ml\) / 11.2 fl oz \(330 ml\)\)](#)
 - ➔ [Loading ink tank \(23.7 fl oz \(700 ml\)\)](#)

▶▶▶ Important

- Do not remove an ink tank during initialization immediately after turning on the printer, or during print head cleaning. Ink may leak out.

►► Note

- Ink tank replacement is possible even during printing, when print jobs are being canceled, or when paper is being advanced.

Selecting Ink Tank Replacement from Menu

1. Select ink display area on HOME screen.

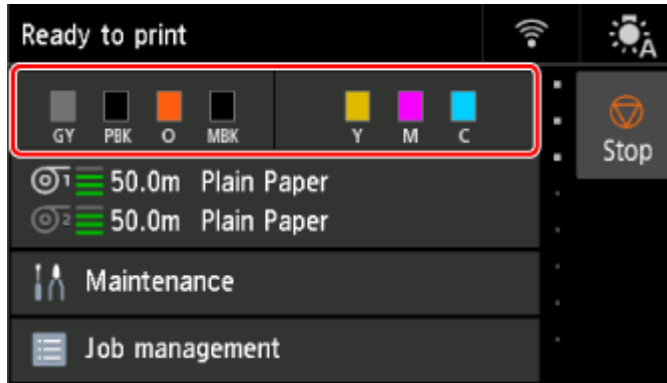

2. Select **Replace**.

Instructions for the ink tank replacement procedure appear on the touch screen.

Removing ink tank (5.4 fl oz (160 ml) / 11.2 fl oz (330 ml))

1. Open ink tank cover and check ink lamp.

The ink lamp flashes if there is no ink left.

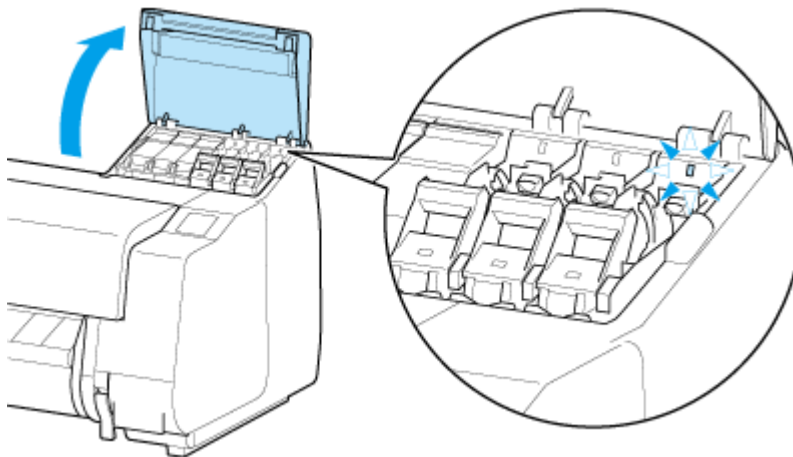

►► Important

- Avoid jarring the printer a lot when replacing an ink tank. Handle the printer gently when replacing tanks. Jarring the printer during printing may affect printing quality.

2. Pull the handle part (A) of the ink tank lock lever of the color to be replaced toward you while pressing the button located at the back of the handle part (B).

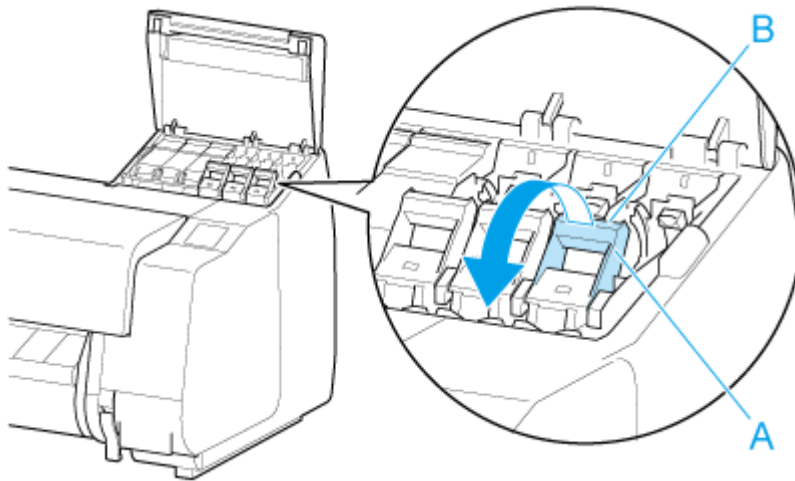

3. Pull out ink tank lock lever.

1. Pull ink tank lock lever straight up.

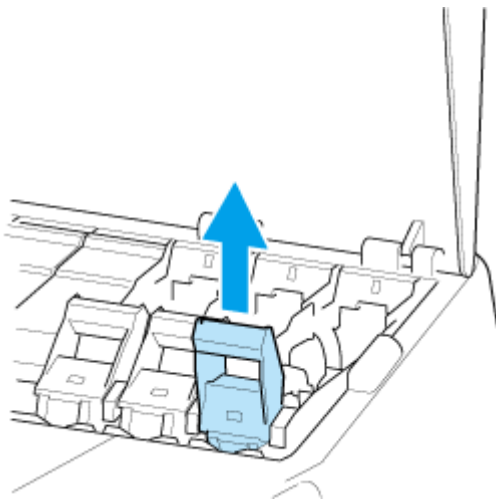

2. Pull ink tank lock lever toward the front.

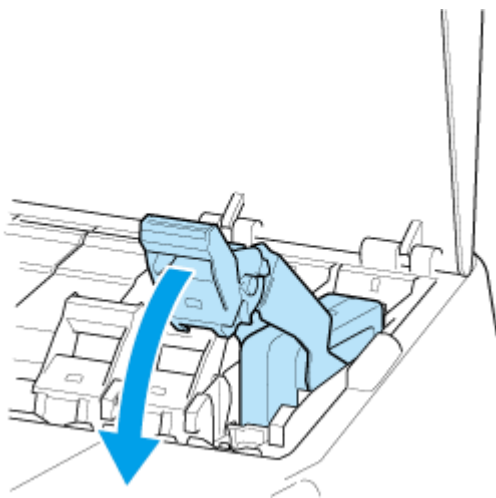

3. Push ink tank lock lever firmly down until it does not return.

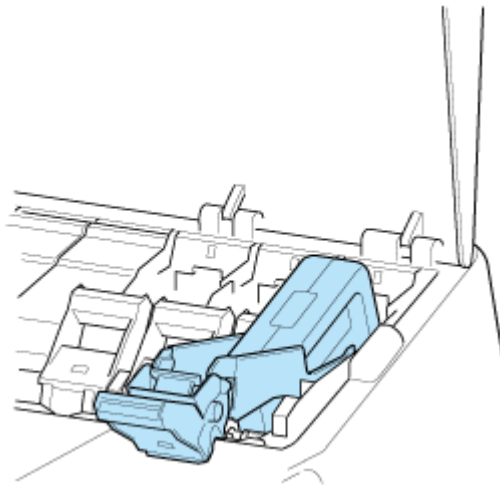

▶▶ Note

- Check that the ink tank lock lever does not return.

4. Hold the ink tank by the grips (C) and remove it.

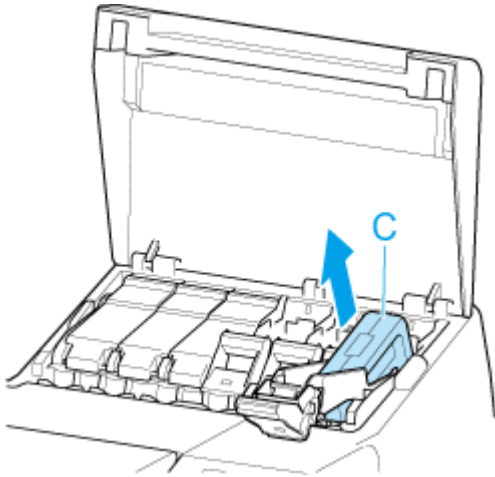

▶▶ Important

- Do not turn off the power of the printer with the ink tank removed except in the case of the preparation for transportation. Otherwise, inside of the ink tank cover may be stained.
- Store the removed ink tank with ink remaining with the ink holes (D) facing up. Otherwise, ink may leak and cause stains. Put the removed ink tank in a plastic bag and close the bag.

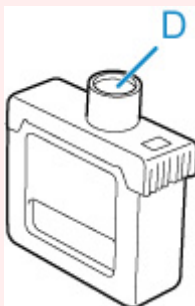

▶▶▶ Note

- Dispose of the used ink tank in accordance with local regulations.

5. Select **OK** on the operation panel.

Removing ink tank (23.7 fl oz (700 ml))

1. Open ink tank cover and check ink lamp.

The ink lamp flashes if there is no ink left.

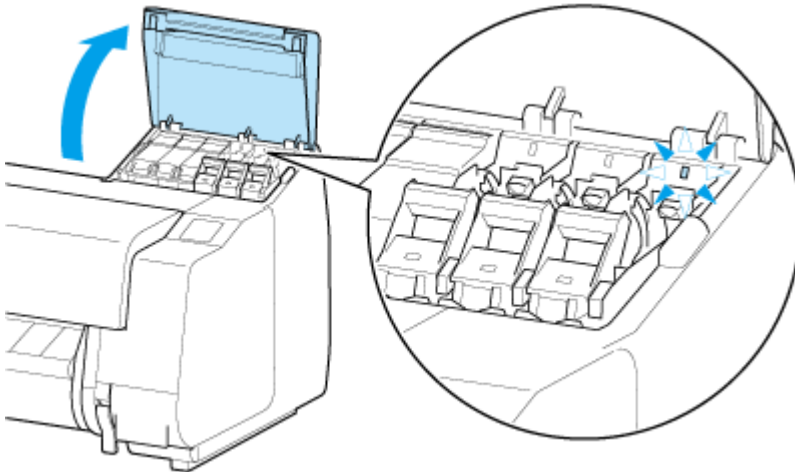

▶▶▶ Important

- Avoid jarring the printer a lot when replacing an ink tank. Handle the printer gently when replacing tanks. Jarring the printer during printing may affect printing quality.

2. Pull the handle part (A) of the ink tank lock lever of the color to be replaced toward you while pressing the button located at the back of the handle part (B).

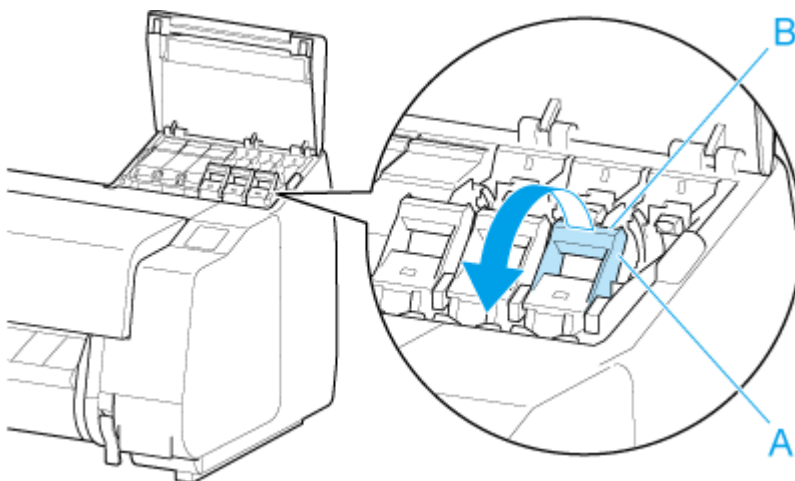

3. Pull out ink tank lock lever.

1. Pull ink tank lock lever straight up.

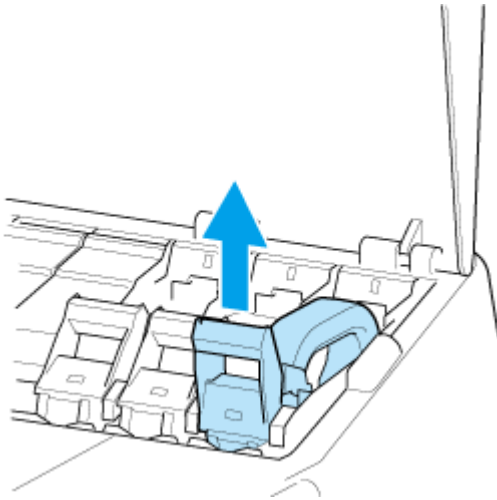

2. Pull ink tank lock lever toward the front.

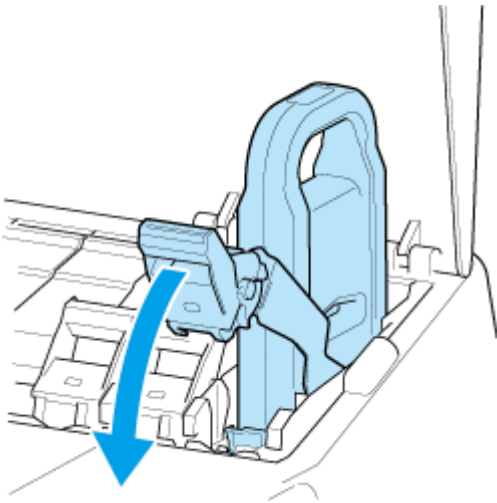

3. Push ink tank lock lever firmly down until it does not return.

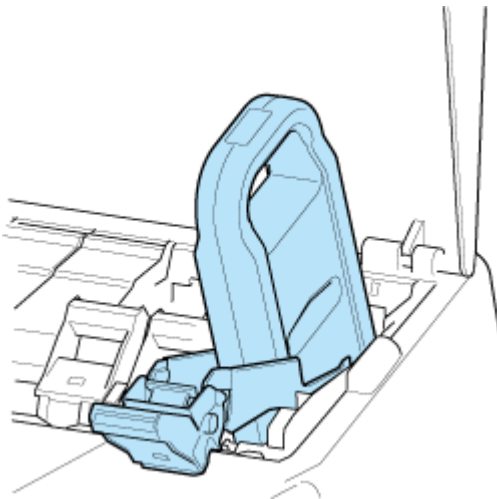

»» Note

- Check that the ink tank lock lever does not return.

4. Use the handle (C) to remove the ink tank.

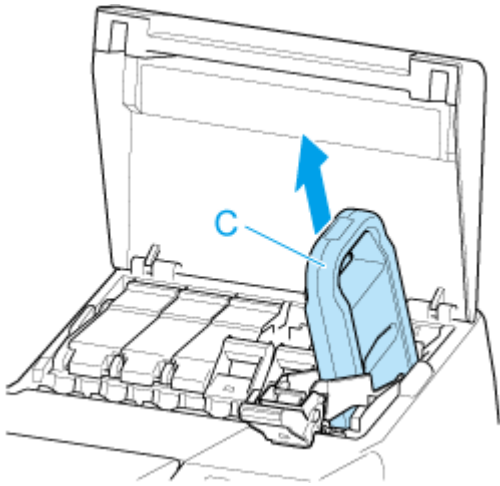

►► Important

- Do not turn off the power of the printer with the ink tank removed except in the case of the preparation for transportation. Otherwise, inside of the ink tank cover may be stained.
- Store the removed ink tank with ink remaining in the box with the ink holes (D) facing up. Otherwise, ink may leak and cause stains.

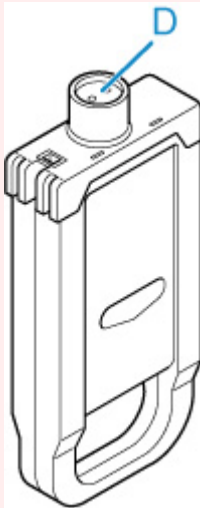

►► Note

- Dispose of the used ink tank in accordance with local regulations.

5. Select **OK** on the operation panel.

Loading ink tank (5.4 fl oz (160 ml) / 11.2 fl oz (330 ml))

1. Before opening the pouch, tilt the ink tank to the left and right gently seven or eight times.

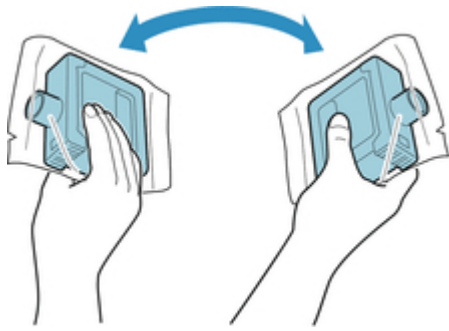

►► Important

- Do not remove and agitate an ink tank that has already been installed in the printer. Ink may leak out.
- Failure to agitate the ink tank may cause the ink components to precipitate and may affect printing quality.

►► Note

- If the ink tank is at a low temperature, allow it to warm up to room temperature before installing.

2. Open the pouch and remove the ink tank.

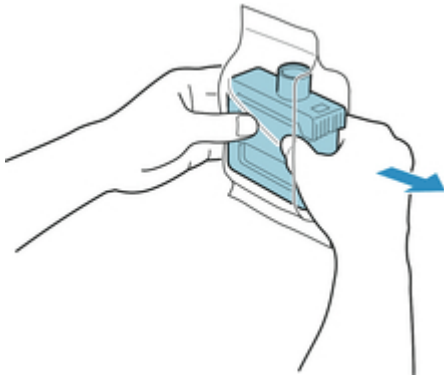

►► Important

- Never touch the ink holes (D) or the metal contacts (E). This may cause stains, damage the ink tank, and affect printing quality.

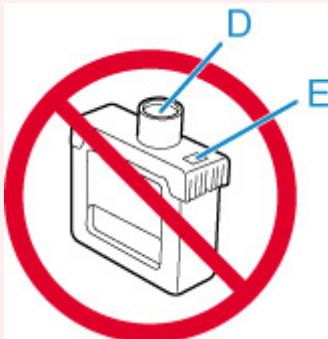

- Avoid dropping the ink tank after removing it from the pouch. Otherwise, ink may leak and cause stains.

3. Select **OK** on the operation panel.

4. Insert the ink tank into the holder with the ink holes facing down and the metal contacts at the rear.

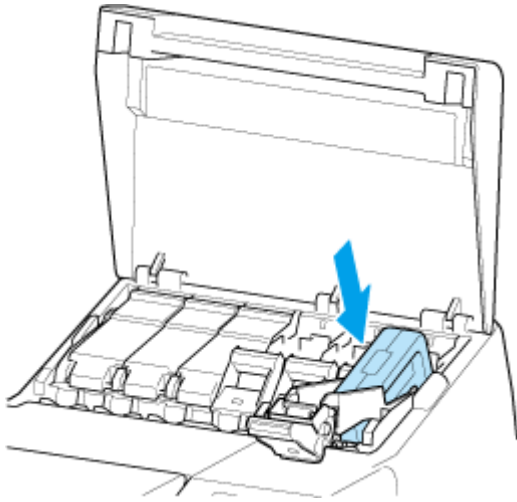

►► Important

- An ink tank cannot be loaded in the holder if the color or orientation is incorrect. If the ink tank does not fit in the holder, do not force it into the holder. Reinstall while checking the label color display, ink tank color, and ink tank orientation.

5. Lift up ink tank lock lever, and then push it down.

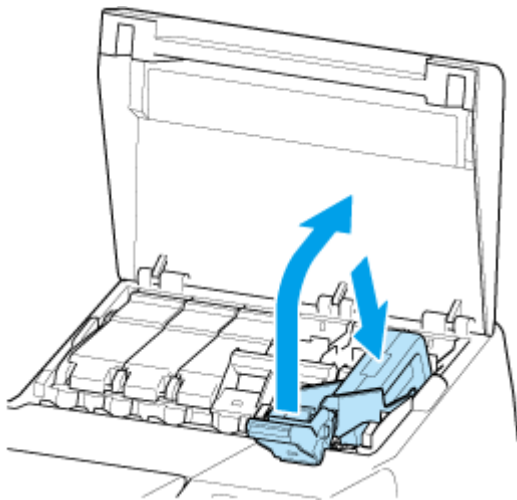

6. Push handle part of ink tank lock lever firmly all the way in.



7. Make sure ink lamp is lit.



▶▶ Note

- If the ink lamp is not lit, reload the tank.

8. Close ink tank cover.

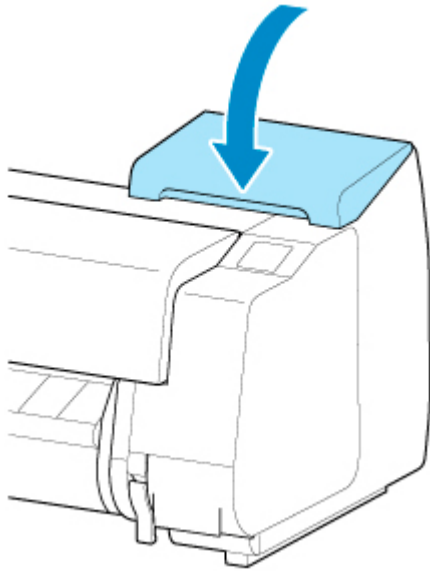

Loading ink tank (23.7 fl oz (700 ml))

1. Before opening the pouch, hold the new ink tank with both hands and tilt it to the left and right as shown, shaking it gently seven or eight times.

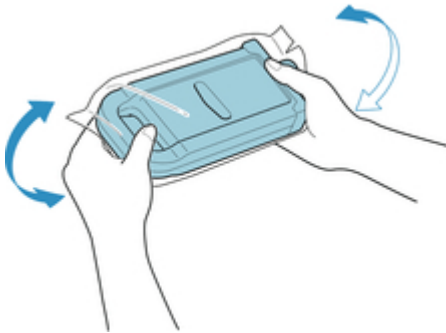

⚠ Caution

- A 23.7 fl oz (700 ml) ink tank is heavy, so use your whole arm to agitate it instead of just your wrist. If you agitate the ink tank using just your wrist, you may injure your wrist.

➤➤➤ Important

- Do not remove and agitate an ink tank that has already been installed in the printer. Ink may leak out.
- Failure to agitate the ink tank may cause the ink components to precipitate and may affect printing quality.

➤➤➤ Note

- If the ink tank is at a low temperature, allow it to warm up to room temperature before installing.

2. Open the pouch and remove the ink tank.

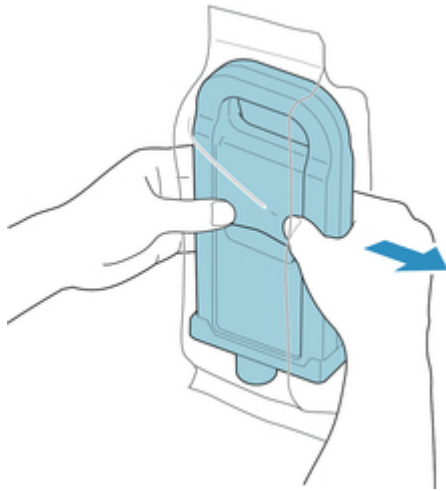

►► Important

- Never touch the ink holes (D) or the metal contacts (E). This may cause stains, damage the ink tank, and affect printing quality.

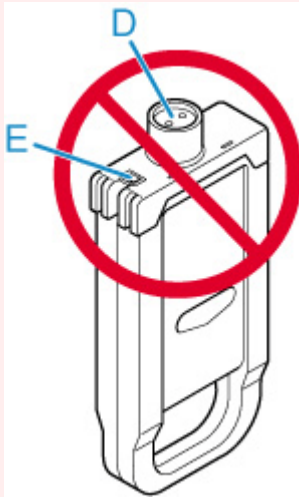

- Avoid dropping the ink tank after removing it from the pouch. Otherwise, ink may leak and cause stains.

3. Select **OK** on the operation panel.

4. Insert the ink tank into the holder with the ink holes facing down and the metal contacts at the rear.

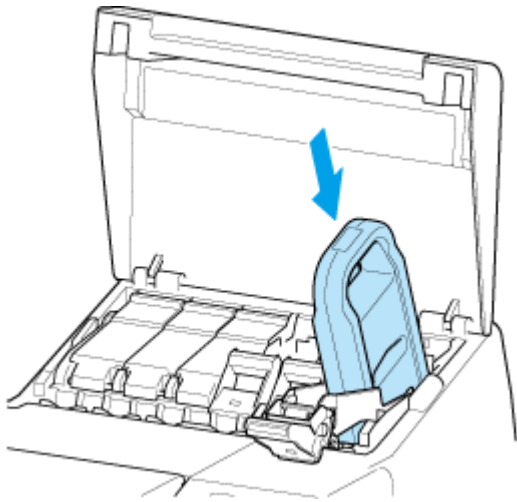

»» Important

- An ink tank cannot be loaded in the holder if the color or orientation is incorrect.
If the ink tank does not fit in the holder, do not force it into the holder. Reinstall while checking the label color display, ink tank color, and ink tank orientation.

- 5.** Lift up ink tank lock lever, and then push it down.

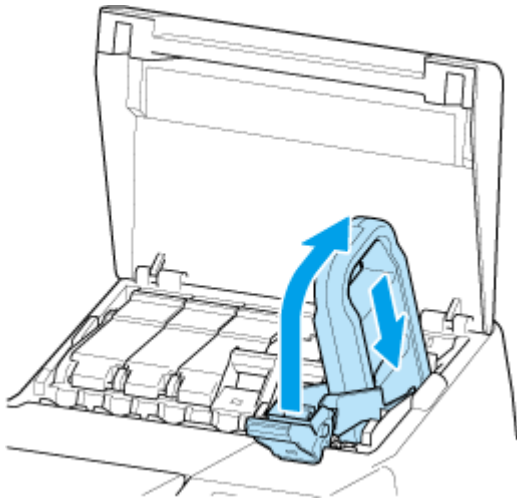

- 6.** Push handle part of ink tank lock lever firmly all the way in.

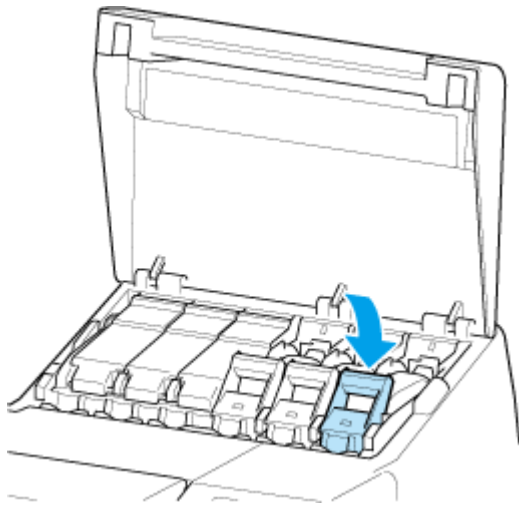

7. Make sure ink lamp is lit.



▶▶▶ **Note**

- If the ink lamp is not lit, reload the tank.

8. Close ink tank cover.

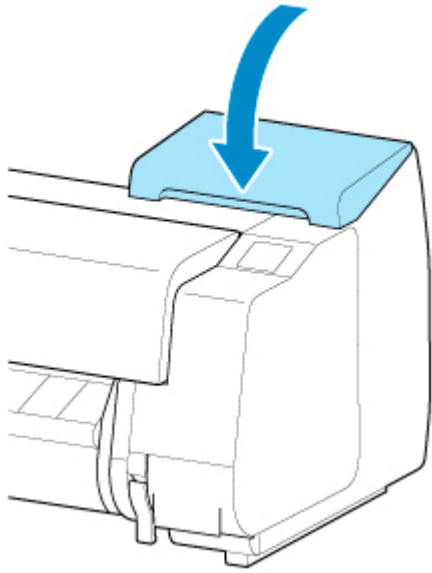

Checking Ink Level

On the touch screen, you can check how much ink is left in the ink tank.



1. Select Ink Display Area on HOME screen.

➔ [Home Screen Menu Composition](#)

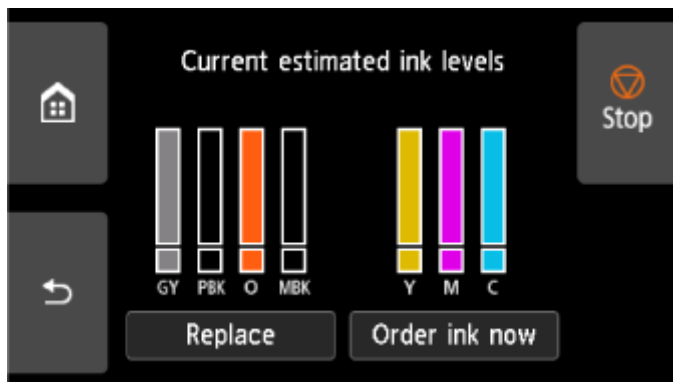
The **Current estimated ink levels** screen appears.



This printer has ink tanks (A) and sub-ink tanks (B). Even if ink runs out, printing can continue with ink in the sub-ink tanks.

When the remaining ink is low,  will appear on the remaining ink level. When ink runs out,  will appear.

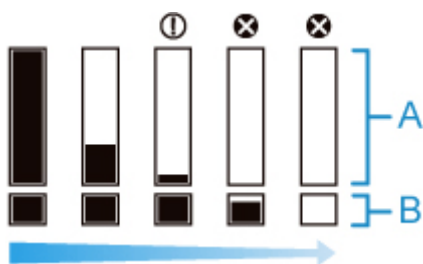

If the touch screen indicates to replace the ink tank, replace the ink tank. If a message is displayed indicating to check the remaining ink levels, or after tasks that consume a lot of ink such as large-format printing or head cleaning, check the remaining levels and replace ink tank as needed.

➔ [Replacing Ink Tanks](#)

➤➤➤ Note

- Select **Order ink now** to view the ink supplier information.
- When the ink tank is replaced, the sub-ink tank will be filled with ink.

During this time,  is displayed above the ink level.



Replacing the Print Head

If the touch screen indicates to replace the print head or if instructed to do so by your Canon dealer, replace the print head.

Compatible Print Head

For details on compatible print head, see [Print Head](#).

Precautions When Handling Print Head

Take the following precautions when handling the print head.

Caution

- For safety, keep print head out of the reach of children.
- If ink is accidentally ingested, contact a physician immediately.
- Do not touch the print head immediately after printing. The print head becomes extremely hot, and there is a risk of burns.

Important

- There may be ink around the nozzles of the print head you remove. Handle the print head carefully during replacement. The ink may stain clothing.
- Do not open the print head pouch until immediately before installation. After removing the print head from the pouch, install it right away. If the print head is left as is after the pouch is opened, the nozzles may dry out, which may affect printing quality.

How to Replace Print Head

Caution

- When replacing the print head immediately after printing, wait a few minutes before replacing it. The metal parts of the print head become hot during printing, and there is a risk of burns from touching these parts.

Important

- Your hands may become dirty during print head replacement. Use the gloves provided in the box with the new print head for replacement.

Note

- Prepare a new ink tank when ink levels are low.
- Prepare a new maintenance cartridge when the remaining capacity of the maintenance cartridge is low.

1. Remove any paper that has been fed.

- ➔ [Removing the Roll from the Printer](#)
- ➔ [Removing Roll Paper from the Roll Unit](#)

➔ [Removing Sheets](#)

2. Clean inside top cover.

➔ [Cleaning Inside the Top Cover](#)

3. Select  **Maintenance** on HOME screen.

4. Select **Head Replacement**.

5. Select **Start head replacement**.

Ink begins being drawn in. When it finishes, instructions for the print head replacement procedure appear on the touch screen.

It takes about 3 to 4 minutes for ink to be drawn into the system and remove ink from the print head.

6. Open top cover.

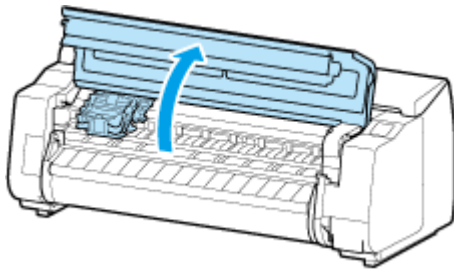

7. If the print head locking cover and print head lock lever are dirty, use a damp cloth that you have wrung out completely to wipe them clean.

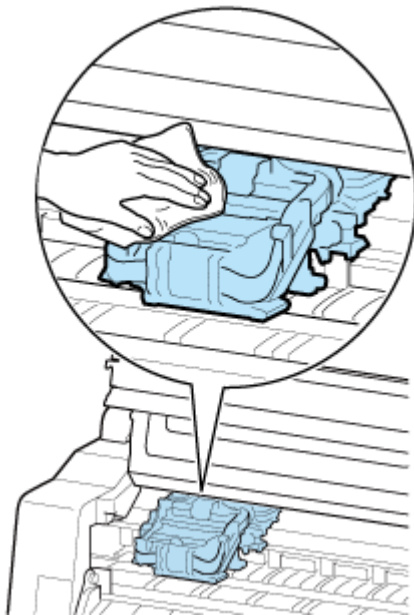

»» Important

- Do not touch the linear scale (A), carriage shaft (B), or ink tube stabilizer (C). Touching these may cause malfunction.

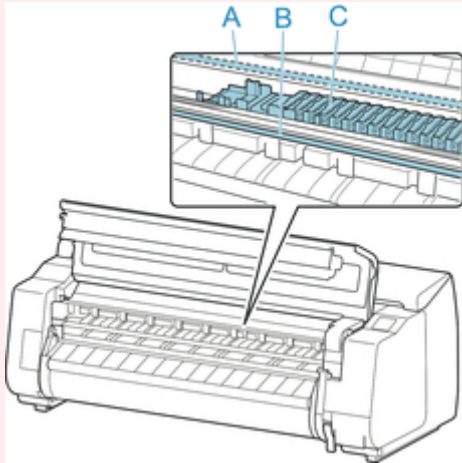

- Do not use tissue paper, paper towels, rough-textured cloth, or similar materials for cleaning so as not to scratch the surface.

8. Pull down print head lock lever toward the front while holding its center (E) with your fingertip.

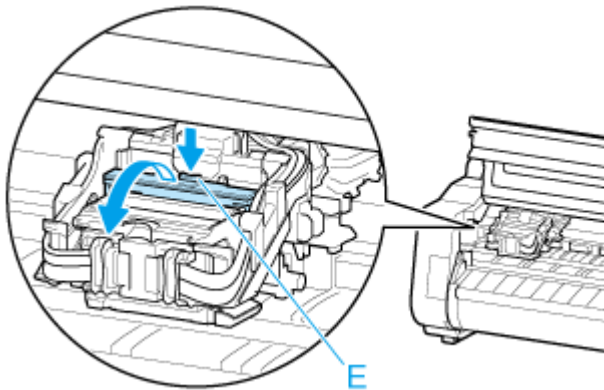

9. Grab grip (F) and open print head locking cover.

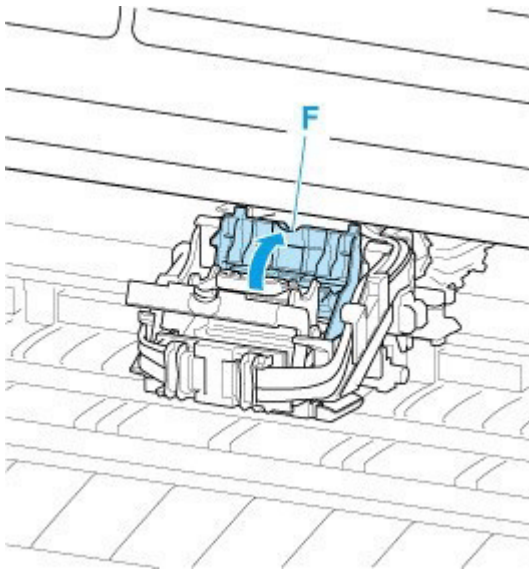

10. Hold the blue handle (G) and remove the print head.

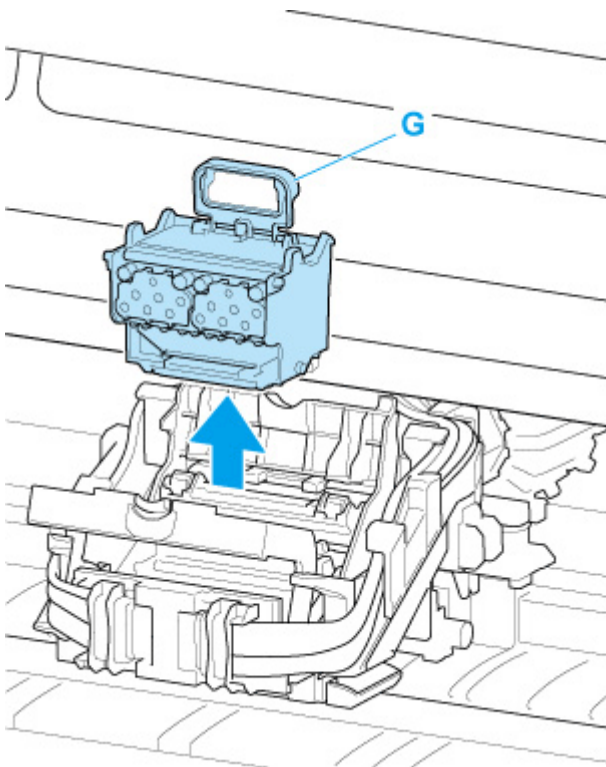

Important

- Never touch the metal contacts of the carriage. Furthermore, do not allow any dirt or debris to become adhered to the metal contacts of the carriage. These may damage the printer.

Note

- Dispose of the used print head in accordance with local regulations.

11. Select **OK** on the operation panel.

12. Remove print head that was in case from pouch.

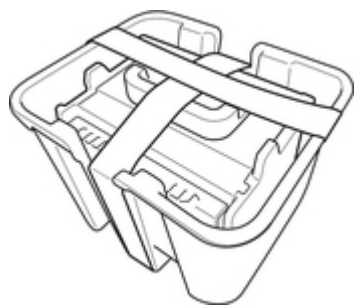

13. Remove tape used to secure print head.

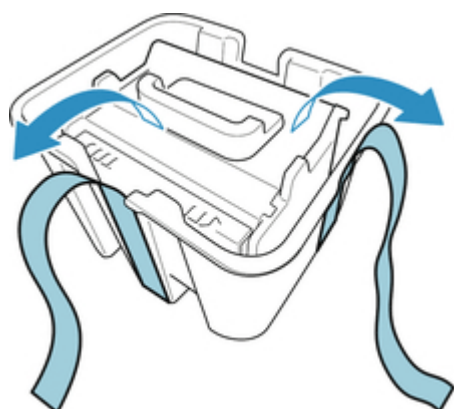

14. Lift print head by blue handle and remove orange protective cap (2).

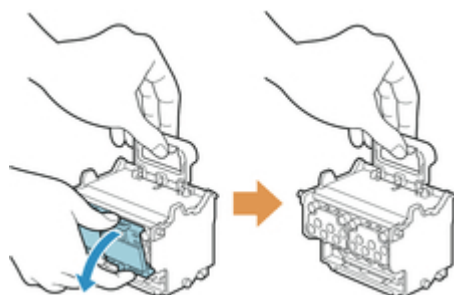

►► Important

- Always carry the print head by the blue handle. Never touch nozzle (H) or metal contacts (I). This may damage the print head and affect printing quality.
- Never touch the ink holes (J). This may affect printing quality.

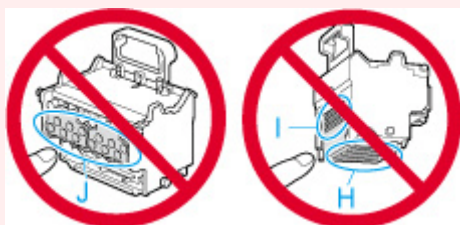

- The inside surface of the protective cap is coated with ink to protect the nozzle. Be careful not to touch these surfaces when removing the caps.
- The print head contains ink to protect the nozzle. We recommend removing the protective cap while holding it over the pouch that contained the print head or otherwise safely out of the way.

to avoid spilling ink and staining your clothes or the surrounding area. If ink accidentally spills, wipe off the ink with a dry cloth.

- If you need to put a print head somewhere temporarily before installation, do not set it down with the nozzles and metal contacts facing down. If the nozzles or metal contacts are damaged, it may affect the printing quality.
- Do not reattach the removed protective part. Dispose of these materials in accordance with local regulations.

15. Turn ink holes (J) toward the front and insert print head into carriage.

Insert the print head all the way into the carriage, while taking care to keep parts that were protected by the protective caps from touching the carriage.

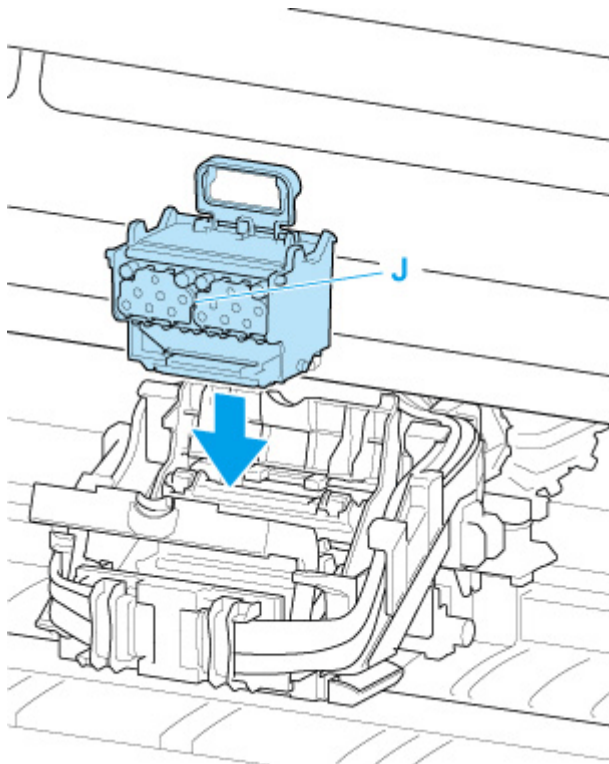

16. Grasp tab (F) of print head locking cover and lower it to front to lock print head.

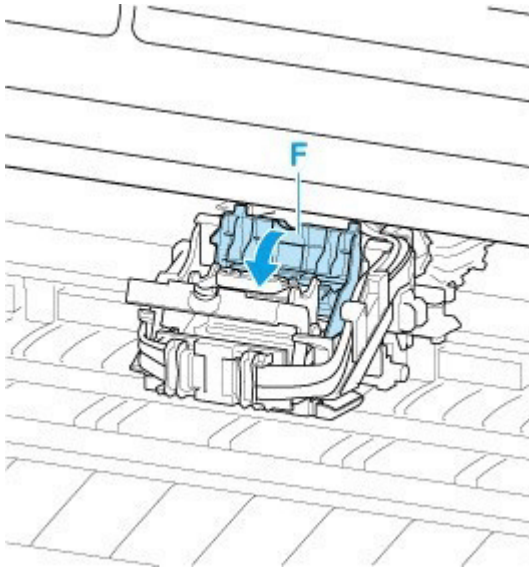

17. While holding center part (K) of print head lock lever, lower it toward back until it clicks.

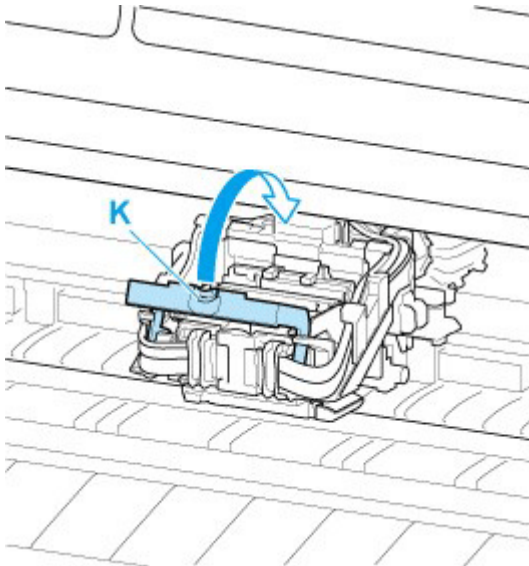

18. Close top cover.

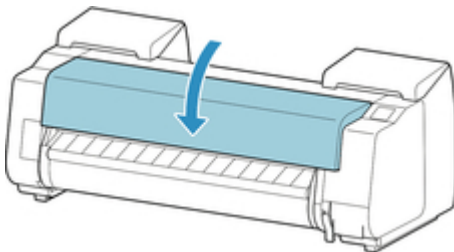

Ink now fills the print head. It takes about 30 minutes.

▶▶▶ Important

- While ink is being filled, definitely do not remove the ink tank or maintenance cartridge. Ink may leak out.

▶▶ Note

- Print head position adjustment is executed when **Print pattern after new head** is set to **ON**.
Follow the instructions on the touch screen to load paper.

➡ [Auto maintenance settings](#)

Replacing the Maintenance Cartridge

Compatible Maintenance Cartridges

For details on compatible maintenance cartridge, see [Maintenance Cartridge](#).

Precautions When Handling Maintenance Cartridge

Take the following precautions when handling the maintenance cartridge.

Caution

- For safety, keep maintenance cartridge out of the reach of children.
- If ink is accidentally ingested, contact a physician immediately.

Important

- Do not remove the maintenance cartridge except to replace it. Ink may leak out.
- Do not remove a maintenance cartridge during initialization immediately after turning on the printer, during print head cleaning, while ink is being drawn out, or during initialization immediately after replacing the maintenance cartridge.

The maintenance cartridge may become damaged or ink may leak out.

- To prevent ink from leaking from a used maintenance cartridge, avoid dropping the cartridge or storing it at an angle. Otherwise, ink may leak and cause stains.
- Ink adheres to the top of the maintenance cartridge after it has been used. Handle the maintenance cartridge carefully during replacement. The ink may stain clothing.

How to Replace a Maintenance Cartridge

If a message indicates you should replace a maintenance cartridge, check the message details and go to step 4.



1. Select **Maintenance** on HOME screen.

2. Select **Maintenance cartridge info**.

3. Select **Replace**.

Instructions for the maintenance cartridge replacement procedure appear on the touch screen.

4. Open box, and remove plastic bag and maintenance cartridge.

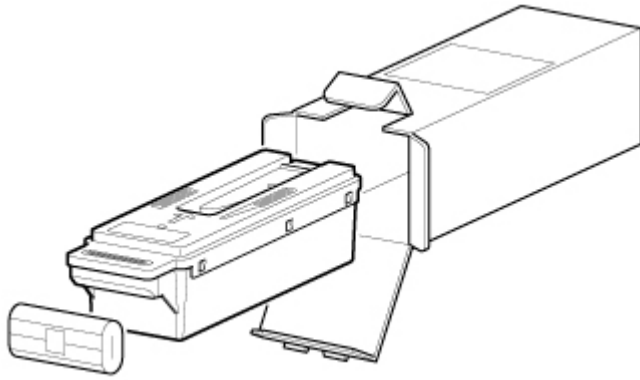

»» Important

- Never touch the metal contacts (A). This may damage the maintenance cartridge.

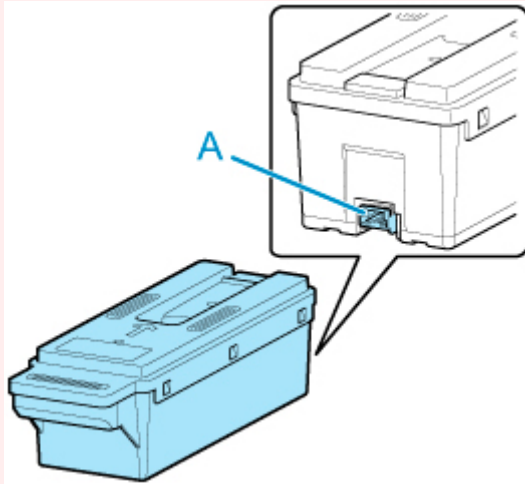

5. Open maintenance cartridge cover.

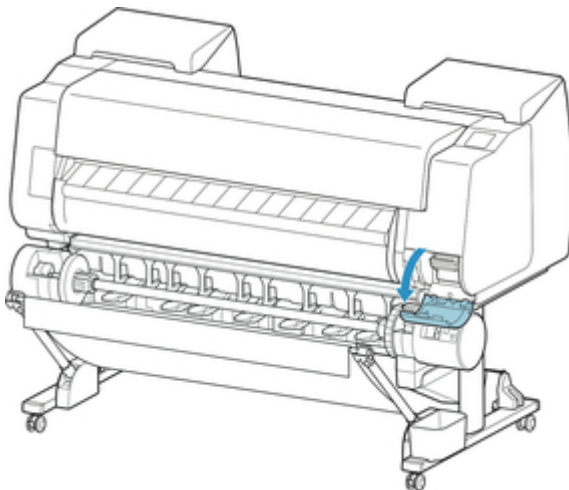

6. Hold the used maintenance cartridge by the grip (B) with one hand and put your other hand under the maintenance cartridge to hold it firmly on the bottom, keeping it level as you pull it out.

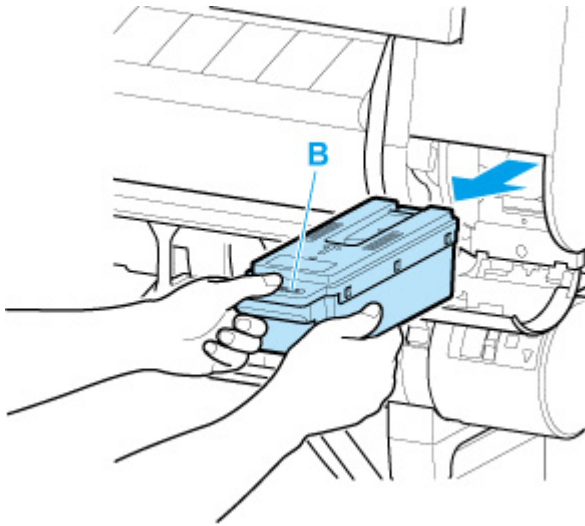

►► Important

- A used maintenance cartridge is heavy. Always grasp the cartridge firmly and keep the cartridge level during removal. If you drop a used maintenance cartridge or store it at an angle, ink may leak and cause stains.

7. Put used maintenance cartridge in supplied plastic bag and store on flat surface.
8. Check the top and bottom of the maintenance cartridge, place in the box, and store the box on a flat surface.

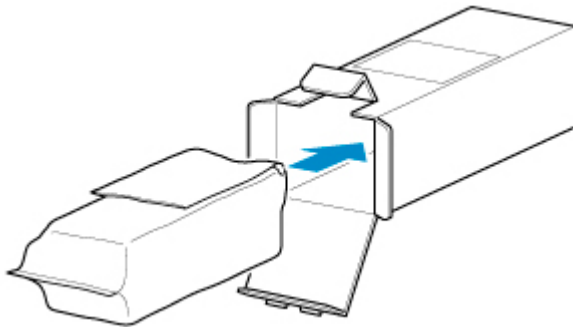

►► Important

- Always put the used maintenance cartridge back in the box and store the box on a flat surface.

►► Note

- Dispose of the used maintenance cartridge in accordance with local regulations.

9. Wipe away any soiling on the maintenance cartridge cover.



»» Important

- Support the maintenance cartridge cover from underneath as you wipe it.

10. Keeping the new maintenance cartridge level, insert it all the way in.

The maintenance cartridge is initialized.

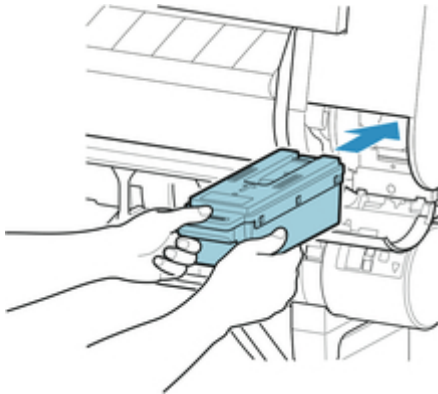

»» Important

- Do not remove the maintenance cartridge during initialization immediately after replacing the maintenance cartridge. The maintenance cartridge may become damaged.

11. Close maintenance cartridge cover.

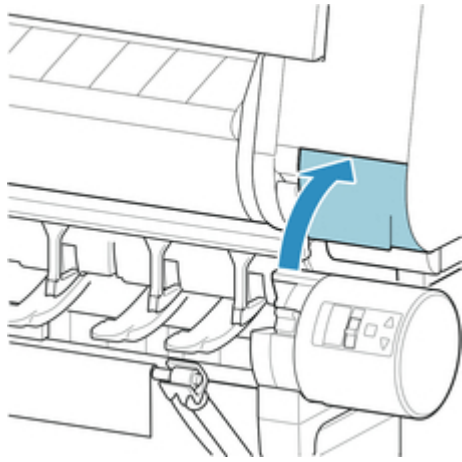

Checking the Remaining Maintenance Cartridge Capacity

The maintenance cartridge absorbs excess ink from borderless printing and print head cleaning. You can confirm the remaining capacity of the maintenance cartridge by checking the touch screen.

1. Select  **Maintenance** on HOME screen.
2. Select **Maintenance cartridge info**.

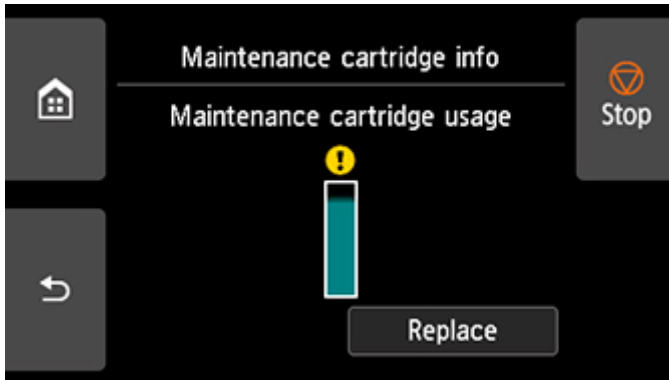

If the touch screen indicates to replace the maintenance cartridge, replace the maintenance cartridge.

If a message appears indicating to check the remaining capacity of the maintenance cartridge, or before tasks that deplete much of the capacity such as head cleaning or preparations to move the printer, check the remaining maintenance cartridge capacity and prepare a new maintenance cartridge as needed.

➔ [Replacing the Maintenance Cartridge](#)

Replacing the Cutter Blade

Compatible Cutter Blade

For details on compatible cutter blade, see [Cutter Blade](#).

How to Replace Cutter Blade

1. Remove any paper that has been fed.

- ➔ [Removing the Roll from the Printer](#)
- ➔ [Removing Roll Paper from the Roll Unit](#)
- ➔ [Removing Sheets](#)



2. Select **Maintenance** on HOME screen.

3. Select **Replace cutter blade unit**.

4. Select **Yes**.

The carriage moves and after it stops moving, instructions for the cutter blade replacement procedure appear on the touch screen.

▶▶▶ Note

- If you do not take action within 2 minutes, cutter blade replacement is canceled. In this case, start over replacement from the beginning.

5. Open top cover.

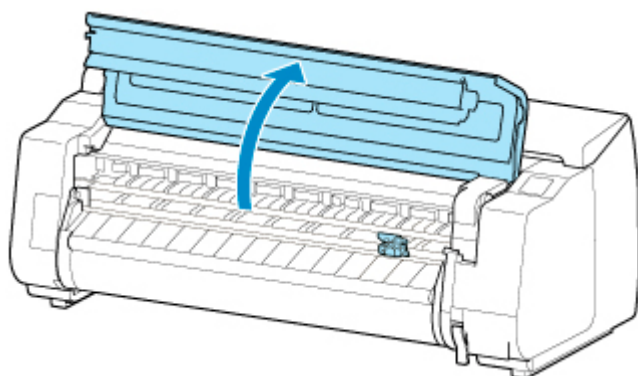

6. If cutter blade is dirty, use damp cloth that you have wrung out completely to wipe it clean.

▶▶▶ Important

- Do not use tissue paper, paper towels, rough-textured cloth, or similar materials for cleaning so as not to scratch the surface.

- Do not touch the linear scale (A), carriage shaft (B), or ink tube stabilizer (C). Touching these may cause malfunction.

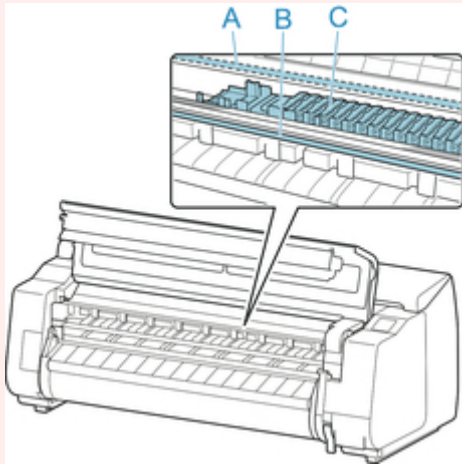

7. Turn hex screw with hex wrench until loose.

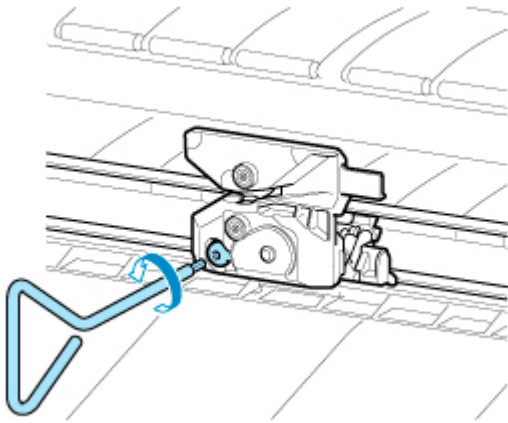

8. Remove cutter blade while holding D.

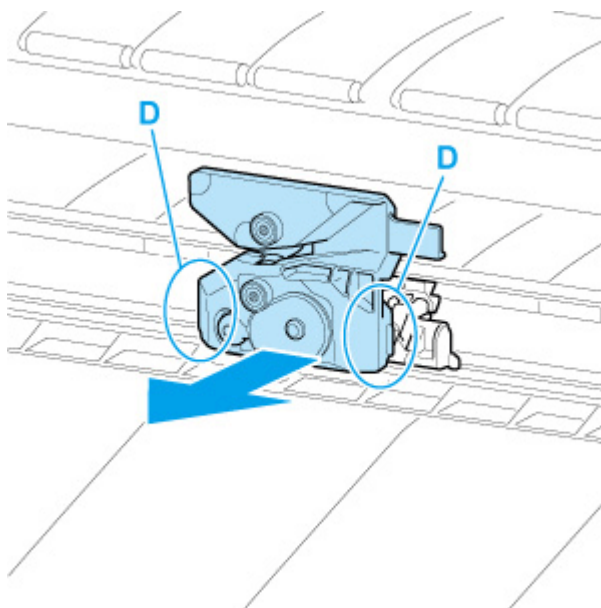

⚠ Caution

- Never touch any part other than D. This may stain your hands or cause injury. Additionally, this may damage the printer.
- Do not disassemble the cutter blade. Touching the blade may cause injury.

➤➤➤ Note

- Dispose of the used cutter blade in accordance with local regulations.

9. Install new cutter blade while aligning E to F and G to H.

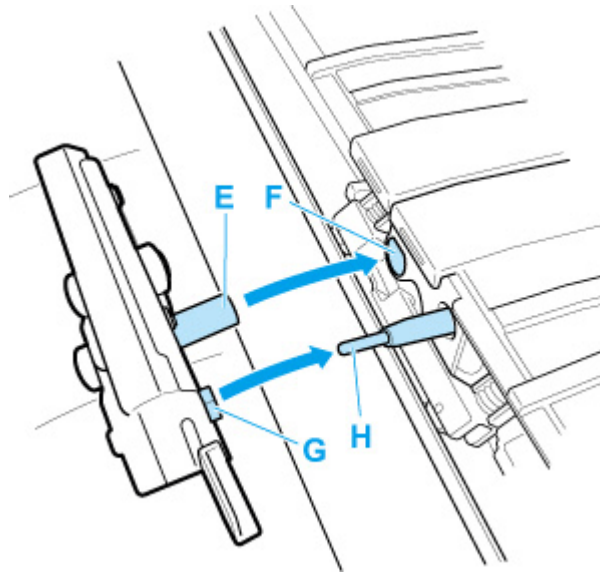

10. Install while aligning fixing part included with replacement cutter blade with center of cutter blade.

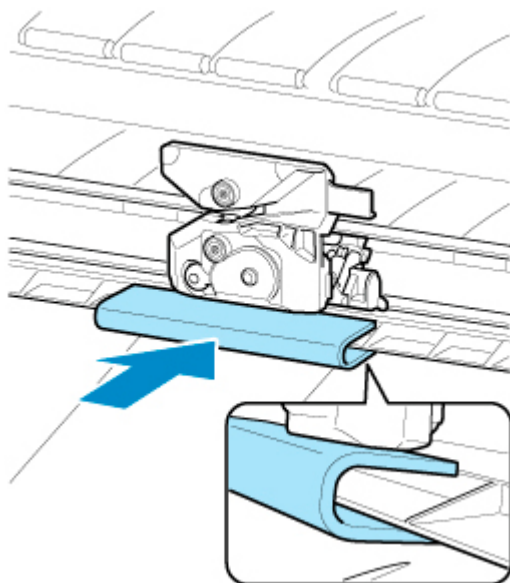

11. Turn hex screw until securely fixed.

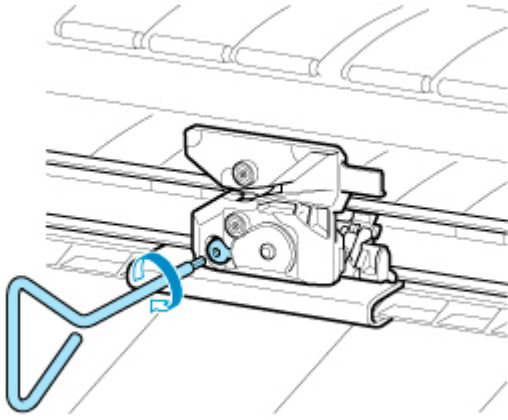

Important

- After the cutter blade is secured, check that the cutter blade does not come off. If the cutter blade comes off, this may damage the printer.

12. Remove fixing part.

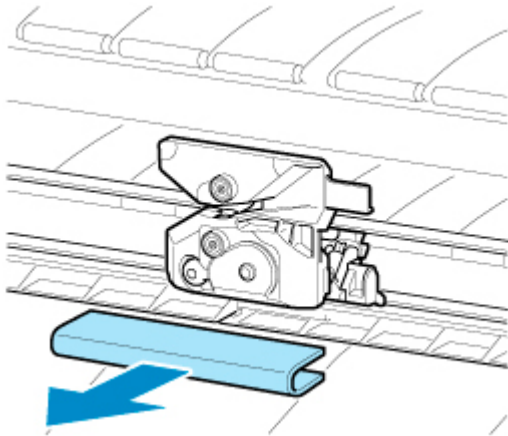

Important

- Always remove the fixing part. Operating with the part installed may damage the printer.

13. Close top cover.

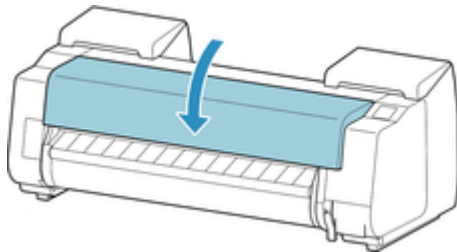

14. Confirm the message and select **Yes.**

Cleaning the Printer

- **Cleaning the Printer Exterior**
- **Cleaning Inside the Top Cover**
- **Cleaning the Roll Unit**
- **Cleaning the Internal Light**

Cleaning the Printer Exterior

Clean the printer regularly to maintain better printing quality and help prevent problems.

To ensure a comfortable working environment, clean the printer exterior about once a month.

▶▶▶ Important

- When the sensor of the feed slot is dirty, the printer might not perform auto feeding properly. Even if the sensor seems clean, we recommend cleaning it because it may have paper dust on it.

1. Turn printer off.

➔ [Turning the Printer On and Off](#)

2. Unplug power cord from outlet.

⚠ Caution

- Always turn off the printer and unplug the power cord before cleaning or maintenance. Accidentally leaving the printer on poses a risk of injury if you touch moving parts inside the printer.
-

3. Wring out a soft cloth dampened with water or watered-down neutral detergent, and use it to wipe off any dirt.

Clean the printer exterior and the power cord plug.

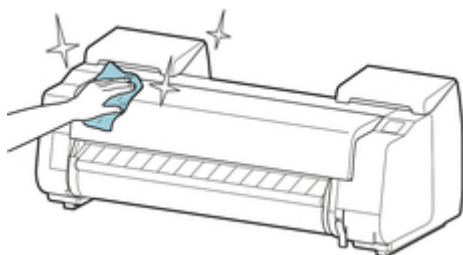

Open the top cover and output guide and clean parts that come in contact with paper (A, B), sensor (C) and window on the back side of the top cover.

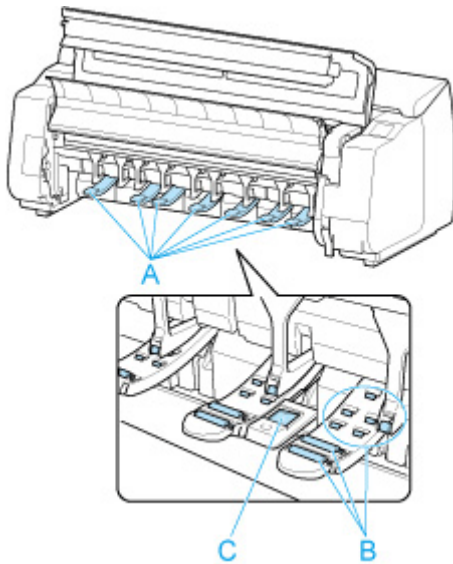

⚠ Warning

- Never use flammable solvents such as alcohol, benzine, or thinner. If these substances come into contact with electrical components inside the printer, there is a risk of fire or electrical shock.

▶▶ Important

- If the output guide is dirty, it may soil the edge of the paper when the paper is cut. We recommend cleaning the output guide even if it does not appear dirty, because it may actually be covered with paper dust.
 - ➔ [Cleaning Inside the Top Cover](#)
- Do not use tissue paper, paper towels, rough-textured cloth, or similar materials for cleaning so as not to scratch the surface.
- When neutral detergent is used, be sure to wipe off the detergent with soft cloth with water.

4. When dirt is wiped off, wipe off water with dry soft cloth.

5. Plug power cord into outlet.

Cleaning Inside the Top Cover

Clean inside the top cover about once a month to maintain better printing quality and help prevent problems.

Also clean inside the top cover in the following situations to ensure optimal operation.

- If the printed surface or the underside of paper is dirty after printing
- After you have used up a roll
- After borderless printing
- After printing on small paper
- After printing on paper that generates a lot of cutting debris
- If you have replaced the roll
- After printing on paper that generates a lot of paper dust
- After printing on adhesive paper

»» Important

- If the platen inside the top cover becomes dirty, it may soil the underside of paper. We recommend cleaning the platen after borderless printing or printing on small paper.
- If the output guide is dirty, it may soil the edge of the paper when the paper is cut. We recommend cleaning the output guide even if it does not appear dirty, because it may actually be covered with paper dust.
- Printing on adhesive paper may leave adhesive on the platen, paper retainer, or other parts. To prevent paper jams, we recommend cleaning inside the top cover after printing.
- Cleaning may not be performed if there is paper in the cleaning area. Remove the paper.

1. Select  **Maintenance** on HOME screen.

2. Select **Platen cleaning**.

3. Check the contents of the message and select **Yes**.

The carriage moves and after it stops moving, instructions appear on the touch screen.

4. Open top cover.

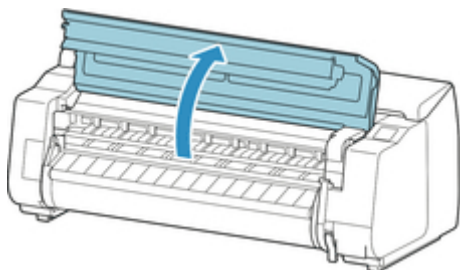

5. If paper dust has accumulated in vacuum holes (A) on platen or in ink grooves (B), use cleaning brush (C), provided with printer, to wipe it away.

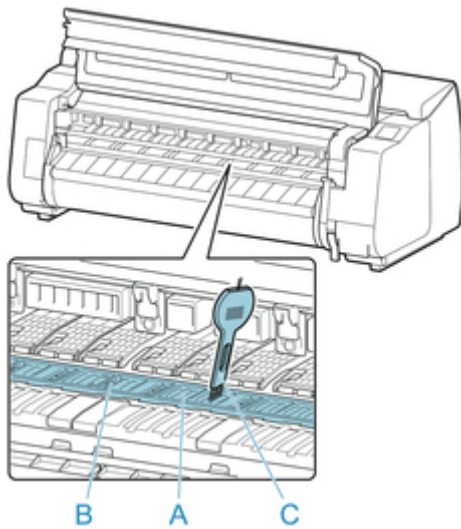

►► Important

- Do not touch the linear scale (D), carriage shaft (E), or ink tube stabilizer (F). Touching these may cause malfunction.

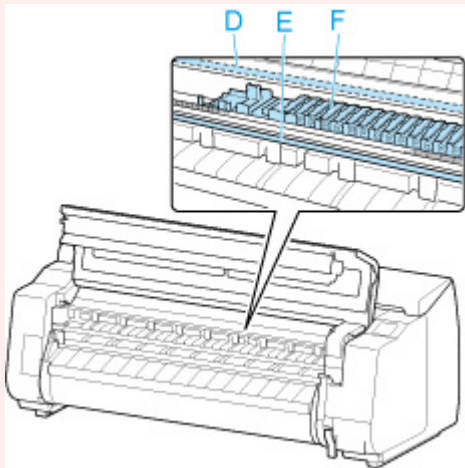

►► Note

- If the cleaning brush is dirty, rinse it in water.

6. Using a damp cloth that you have wrung out completely, wipe inside the top cover to clean it.

Wipe away any ink residue and paper dust (debris from cutting) on top cover roller (G), paper retainer (H), entire platen (I), ink grooves (J, K, L) and its surroundings, output guide (M), and so on.

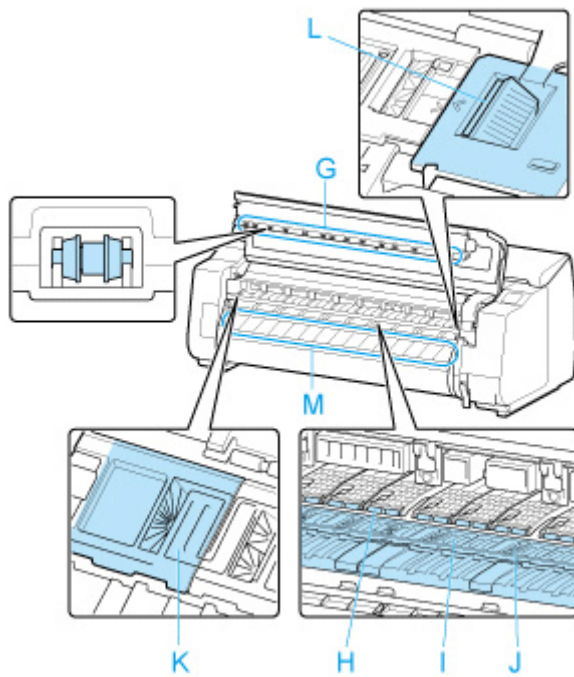

⚠ Warning

- Never use flammable solvents such as alcohol, benzene, or thinner. If these substances come into contact with electrical components inside the printer, there is a risk of fire or electrical shock.

▶▶ Important

- Do not use a dry cloth to wipe inside the top cover. This may create a static charge, which may attract dust and affect the printing quality.
- Do not use tissue paper, paper towels, rough-textured cloth, or similar materials for cleaning so as not to scratch the surface.

7. Close top cover.

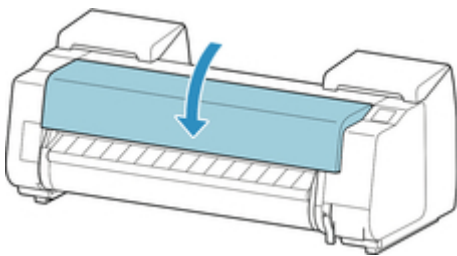

Cleaning the Roll Unit

About once a month, clean the roll unit to ensure optimal operation.

►► Important

- When the sensor of the feed slot is dirty, the printer might not perform auto feeding properly. Even if the sensor seems clean, we recommend cleaning it because it may have paper dust on it.

1. Remove the roll paper from the roll unit.

➔ [Removing Roll Paper from the Roll Unit](#)

2. Turn printer off.

➔ [Turning the Printer On and Off](#)

3. Unplug power cord from outlet.

⚠ Caution

- Always turn off the printer and unplug the power cord before cleaning or maintenance. Accidentally leaving the printer on poses a risk of injury if you touch moving parts inside the printer.

4. Wipe away any residue and paper dust from areas (A, B) that come in contact with paper and sensor (C) with a thoroughly wrung out damp cloth, and wipe dry with a dry cloth.

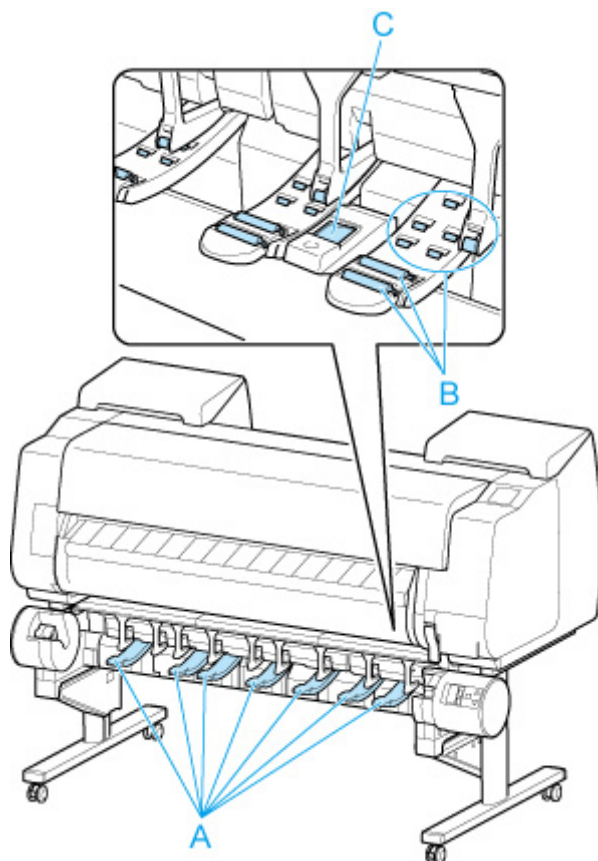

 **Warning**

- Never use flammable solvents such as alcohol, benzine, or thinner. If these substances come into contact with electrical components inside the roll unit, there is a risk of fire or electrical shock.
-

5. Plug power cord into outlet.

Cleaning the Internal Light

Clean the printer regularly to maintain better printing quality and help prevent problems.

To ensure a comfortable working environment, clean the lights inside the printer about once a month.

1. Turn printer off.

➔ [Turning the Printer On and Off](#)

2. Unplug power cord from outlet.

⚠ Caution

- Always turn off the printer and unplug the power cord before cleaning or maintenance. Accidentally leaving the printer on poses a risk of injury if you touch moving parts inside the printer.

3. Open top cover.

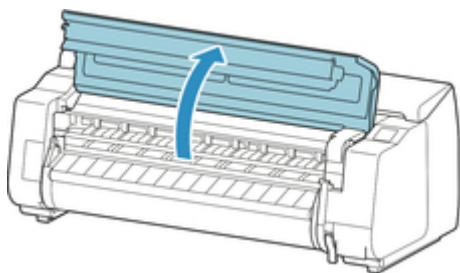

4. Wring out a soft cloth dampened with water or watered-down neutral detergent, and use it to wipe off any dirt.

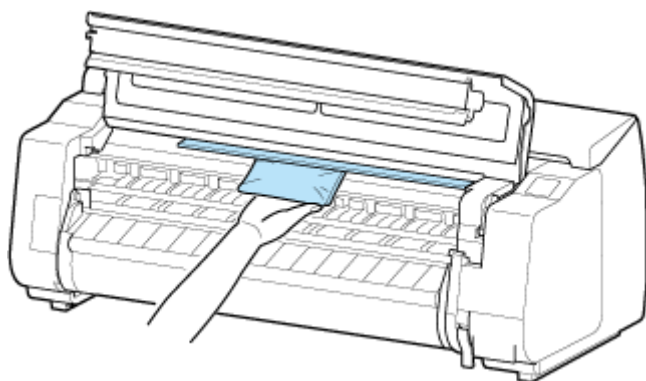

⚠ Warning

- Never use flammable solvents such as alcohol, benzene, or thinner. If these substances come into contact with electrical components inside the printer, there is a risk of fire or electrical shock.

➤➤➤ Important

- Do not use tissue paper, paper towels, rough-textured cloth, or similar materials for cleaning so as not to scratch the surface.

- When neutral detergent is used, be sure to wipe off the detergent with soft cloth with water.

5. When dirt is wiped off, wipe off water with dry soft cloth.

6. Close top cover.

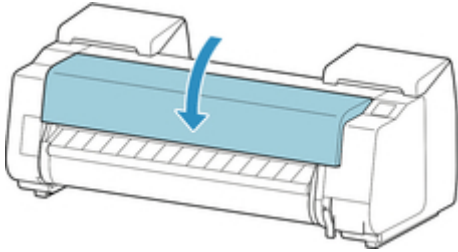

7. Plug power cord into outlet.

Performing Maintenance Functions from Your Computer (macOS)

- **Opening Remote UI for Maintenance**
- **Cleaning the Print Heads**
- **Printing a Nozzle Check Pattern**

Opening Remote UI for Maintenance

You can perform maintenance of printer and change the settings from a Remote UI. The following is the procedure to open a Remote UI.

1. Open **System Settings**, and select **Printers & Scanners**
2. Select your model from the printer list, and click **Options & Supplies...**
3. Click **Show Printer Webpage...** in **General** tab

Remote UI starts.

▶▶▶ Note

- The password may have to be entered after Remote UI starts. In such a case, enter the password and click **OK**. In case you do not know the password, see "Password and Cookie."

Related Topics

- ➔ [Cleaning the Print Heads](#)
- ➔ [Printing a Nozzle Check Pattern](#)
- ➔ [Checking the Ink Status from Your Computer](#)
- ➔ [Updating Media Information in Printer Driver](#)
- ➔ [Correcting Media Information in Printer Driver \(When Printer Used in Shared Environment\)](#)
- ➔ [Confirm the Printer Paper Information](#)

Cleaning the Print Heads

The print head cleaning and Cleaning functions allow you to clear up clogged print headnozzle. Perform print head cleaning if printing is faint or a specific color fails to print, even though there is enough ink. If you perform Cleaning and the condition still does not improve, perform system cleaning.

The procedure for cleaning is as follows:

Cleaning

1. Select **Utilities** from [Remote UI](#)

2. Click **Cleaning**

Before running the cleaning, check the following items:

Check that the printer power is on. Then open the Ink Tank Cover.

Check the following items for each ink. Then, if necessary, perform **Cleaning**.

- [Is there ink remaining in the tank?](#)
- Is the ink tank attached properly?
If the Ink Lamp is not lit, remove it and attach it again.
- Did you install the ink tanks in their correct positions?

3. Execute cleaning

Click **Yes**.

Print head cleaning starts.

4. Check the results

Check the print results.

If cleaning the head once does not resolve the print head problem, clean it once more.

»» Important

- **Cleaning** consumes a small amount of ink.
Cleaning the print head frequently will rapidly deplete your printer's ink supply. Consequently, perform cleaning only when necessary.

Deep Cleaning

Deep Cleaning is more thorough than cleaning. Perform deep cleaning when two **Cleaning** attempts do not resolve the print head problem.

1. Select **Utilities** from [Remote UI](#)

2. Click **Deep Cleaning**

Before running the deep cleaning, check the following items:

Check that the printer power is on. Then open the Ink Tank Cover.

Check the following items for each ink. Then, if necessary, perform **Deep Cleaning**.

- [Is there ink remaining in the tank?](#)
- Is the ink tank attached properly?
If the Ink Lamp is not lit, remove it and attach it again.
- Did you install the ink tanks in their correct positions?

3. Execute deep cleaning

Click **Yes**.

Print head deep cleaning starts.

4. Check the results

Check the print results.

»» Important

- **Deep Cleaning** consumes a larger amount of ink than **Cleaning**.
Cleaning the print head frequently will rapidly deplete your printer's ink supply. Consequently, perform cleaning only when necessary.

System Cleaning

Execute **System Cleaning** if the status does not improve even after **Deep Cleaning** is performed.

1. Select **Utilities** from [Remote UI](#)

2. Click **System Cleaning**

Before running the system cleaning, check the following items:

Check that the printer power is on. Then open the Ink Tank Cover.

Check the following items for each ink.

- [Is there ink remaining in the tank?](#)
- Is the ink tank attached properly?
If the Ink Lamp is not lit, remove it and attach it again.
- Did you install the ink tanks in their correct positions?

In addition, **System Cleaning** consumes an extremely large amount of ink.

Before executing this function, check the items below. Then, if you feel it necessary, execute **System Cleaning**.

- Did you use **Nozzle Check** to check the nozzle status and was there a problem?
- Did the status remain unchanged even after **Deep Cleaning** was executed?

3. Execute system cleaning

Click **Yes**.

System cleaning starts.

4. Check the results

Check the print results.

▶▶▶ Important

- **System Cleaning** consumes an extremely large amount of ink. Executing system cleaning frequently will rapidly deplete your printer's ink supply. Therefore, execute system cleaning only when necessary.

Related Topic

➔ [Printing a Nozzle Check Pattern](#)

Printing a Nozzle Check Pattern

The nozzle check function allows you to check whether the print head is working properly by printing a nozzle check pattern. Print the pattern if printing becomes faint, or if a specific color fails to print.

The procedure for printing a nozzle check pattern is as follows:

Nozzle Check

1. Select **Utilities** from [Remote UI](#)

2. Click **Nozzle Check**

Before printing the nozzle check pattern, check the following items:

Check that the printer power is on. Then open the Ink Tank Cover.

Check the following items for each ink. Then, if necessary, perform **Nozzle Check**.

- [Is there ink remaining in the tank?](#)
- Is the ink tank attached properly?
If the Ink Lamp is not lit, remove it and attach it again.
- Did you install the ink tanks in their correct positions?

3. Print a nozzle check pattern

Click **Yes**.

Printing of the nozzle check pattern begins.

4. Check the print result

Check the print result.

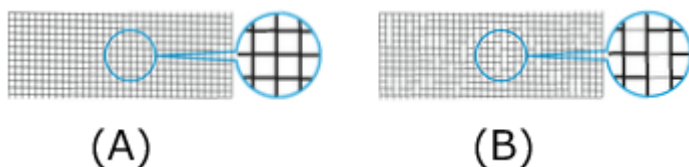

(A) As long as the horizontal lines are in line, and not missing, the nozzle is working normally.

(B) Where the horizontal lines are not in line or are missing, the color nozzle is blocked.

From the nozzle check pattern printing results, if it becomes patchy or there are areas that cannot be printed, clean the print heads from **Cleaning**.

Related Topic

➔ [Cleaning the Print Heads](#)

Other Maintenance

- **Preparing to Transfer the Printer**
- **Reinstalling the Printer**
- **Firmware update**

Preparing to Transfer the Printer

To protect the internal parts in transit, always follow these steps before transferring the printer to a new location.

For details on installing the printer after transfer, see [Reinstalling the Printer](#).

▶▶▶ Important

- Be sure to contact your Canon dealer before transferring the printer to a new location. Ink may leak and damage the printer if you do not prepare the printer correctly and it is tipped or stood on end in transit.
- When moving the printer, make sure that the basket does not rub against the floor. If the basket rubs on the floor, it may get dirty or damaged.
- When you select **Prepare to move**, any registered web services will be canceled. After moving your printer, set up your web services again.

➔ [Web service setup](#)

▶▶▶ Note

- The maintenance cartridge replacement may be required when you execute the **Prepare to move** menu. Prepare the maintenance cartridge in advance while referring below. The number of maintenance cartridge required varies depending on the amount remaining in the maintenance cartridge being used.
- If you can move the printer in a level state using casters or something similar, you do not need to execute **Prepare to move**.
- Always follow the instructions of the service representative when preparing to transfer the printer.

The following lists transport restrictions by type of transport.

Move indoors on the same floor

Usage Examples: Move indoors by carrying

- Transport and storage in low temperature environments: No
- Permitted angle of inclination: All directions: within 30°
- Required maintenance cartridges: 1-3

Move indoors to a different floor

Usage Examples: Moving the printer while temporarily tilting it such as when using the stairs

- Transport and storage in low temperature environments: No
- Permitted angle of inclination: All directions: within 90°
- Required maintenance cartridges: 1-3

Transport outdoors

Usage Examples: Transport By Vehicle

- Transport and storage in low temperature environments: Yes
- Permitted angle of inclination: All directions: within 90°
- Required maintenance cartridges: 3

Preparing for Transportation

1. Remove the paper.
 - ➔ [Removing the Roll from the Printer](#)
 - ➔ [Removing Roll Paper from the Roll Unit](#)
 - ➔ [Removing Sheets](#)
2. If touch screen indicates to replace maintenance cartridge, replace maintenance cartridge.
 - ➔ [Replacing the Maintenance Cartridge](#)



3. Select **Maintenance** on HOME screen.
4. Select **Prepare to move**.
5. Select **Move indoors on the same floor, Move indoors to a different floor or Transport outdoors**.
6. Check the contents of the message and select **Yes**.

The printer is now prepared for transfer.

When the preparation is finished, a message prompting you to open the ink tank cover appears on the touch screen.

▶▶▶ Important

- If consumables must be replaced, a message appears on the touch screen, and preparation is disabled. If the message appears, select **OK** and contact your Canon dealer for assistance.

7. Open ink tank cover to remove all ink tanks.
 - ➔ [Removing ink tank](#)
8. Push down release lever (A) as shown as you gently return all ink tank lock levers to their original positions.

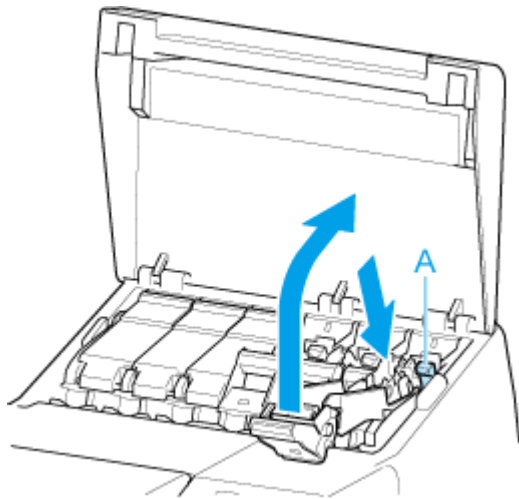

9. Close ink tank cover.

Ink is now drawn into the maintenance cartridge.

A confirmation message will appear when the process is finished.

»» Important

- Do not remove the maintenance cartridge except when the message indicating replacement is displayed.

If you remove the maintenance cartridge while ink is being removed, the ink may leak out.

10. Turn printer off.

➔ [Turning the Printer On and Off](#)

Packing Printer

1. Disconnect power cord and interface cable.

»» Important

- Turn off the printer before you unplug it. Unplugging the printer before it is off and moving it may damage the printer. If you accidentally unplug the printer, plug it in again, reinstall the ink tanks, and follow this procedure again.

2. Open top cover.

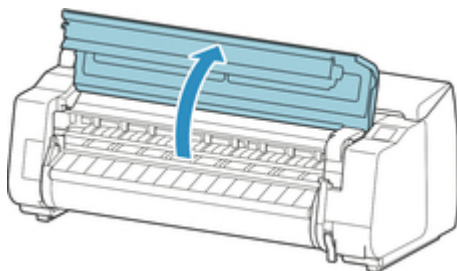

3. Grasp Belt and insert Belt Stopper into position shown.

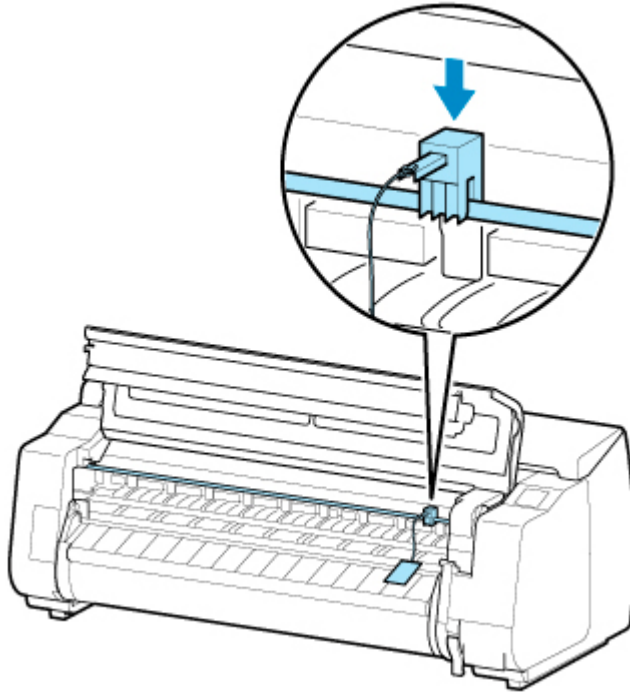

»» Important

- Attach the Belt Stopper that was removed and stored after initial installation. Neglecting to attach the Belt Stopper may damage the printer.
- Do not touch the linear scale (A), carriage shaft (B), or ink tube stabilizer (C). Touching these may cause malfunction.

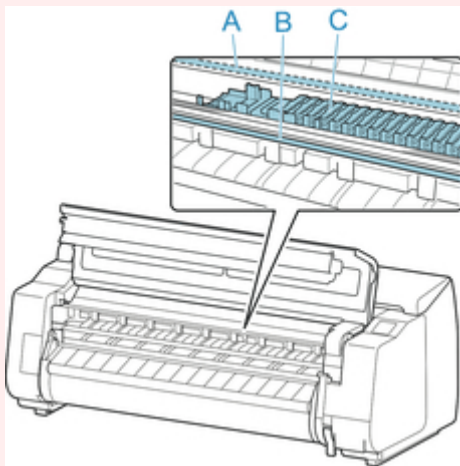

4. Close top cover.

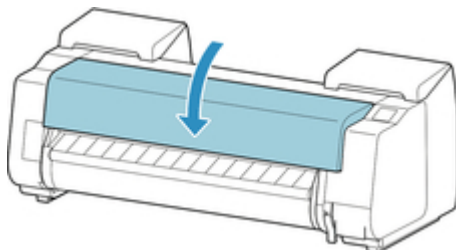

5. Tape down printer covers to secure them, in the reverse order of tape removal during installation.

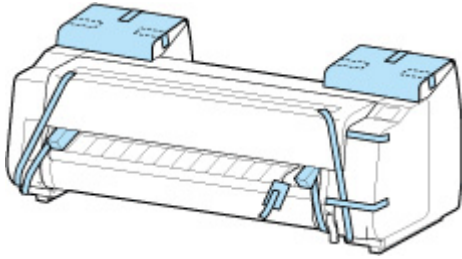

6. Remove basket by reversing installation procedure.
7. Remove roll unit by reversing installation procedure.
8. Remove the Stand by reversing the installation procedure, when it was attached to the printer.
9. Disassemble and repackage the stand by following the installation procedure in reverse.
10. Repack roll holder, holder stopper, and printer in shipping materials, and then package them in shipping box.

Reinstalling the Printer

The basic workflow for reinstalling the printer is as follows.

For detailed instructions, see the Installation Guide.

⚠ Caution

- Moving the printer requires at least six people, holding it on both sides. Be careful to avoid back strain and other injuries.
- When carrying the printer, hold it securely by the carrying grips (A) on the bottom left, right, and rear. The printer may be unsteady if you hold it at other positions, which poses a risk of injury from dropping the printer.

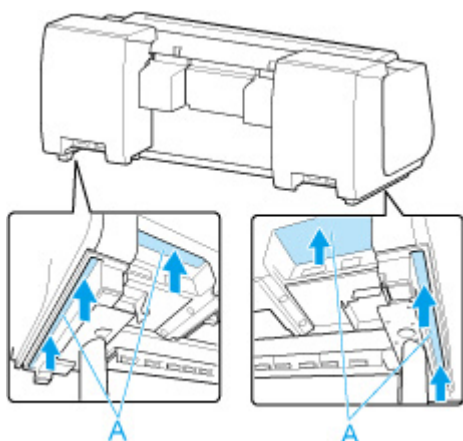

1. Remove tape and packaging material attached to the printer.

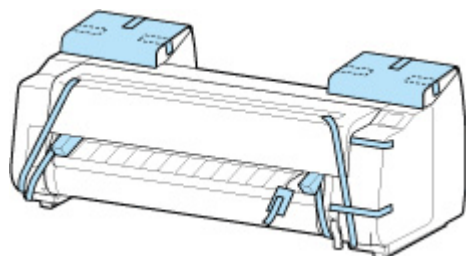

2. Open the top cover and remove the belt stopper.
3. Referring to the Printer Stand Setup Guide, assemble the Stand.

⚠ Caution

- The Stand must be assembled by at least two people on a flat surface. Attempting assembly by yourself poses a risk of injury or bending the Stand.
- When assembling the Stand, lock the casters. In addition, always unlock the casters before moving the assembled Stand. Attempting to move the stand when the casters are locked poses a risk of injury or damage to the location site.

- When placing the printer on the stand, lock all four of the casters of the stand. Attempting to place the printer on the stand while the casters are not locked poses a risk of injury.
-

4. If using roll unit, refer to Setup Guide provided with roll unit and attach roll unit to Stand.

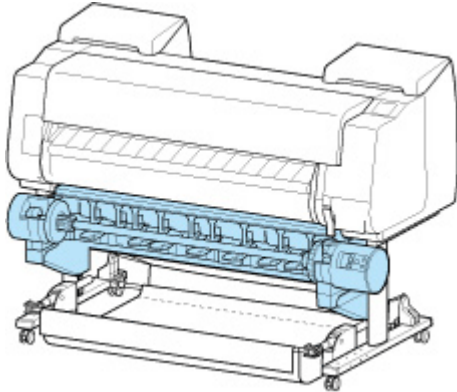

5. If using basket, refer to Printer Stand Setup Guide and attach basket to Stand.

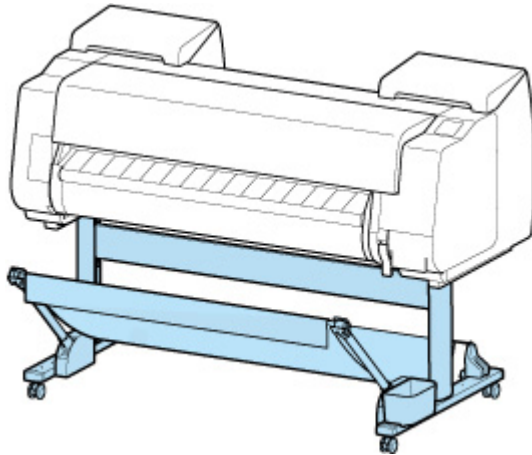

6. Connect the power cord to the power cord connector on the back of the printer.

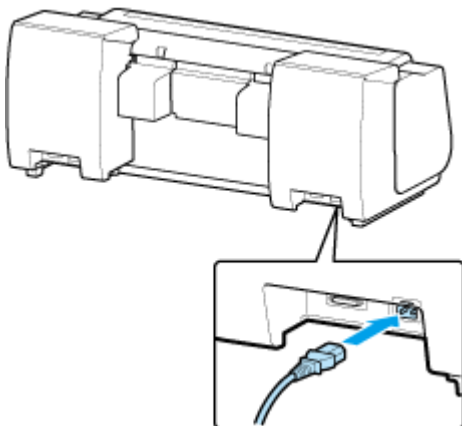

7. Plug the power cord into the outlet.

8. Turn printer on.

➡ [Turning the Printer On and Off](#)

9. Check the contents of the message and select **Yes**.

10. Open the ink tank cover and install all ink tanks.

➡ [Loading ink tank](#)

11. Install the software.

Note that the driver installation procedure varies depending on the type of connection.

➡ Installing the Printer Driver (Windows)

➡ [Installing the Printer Driver](#) (macOS)

➤➤ Important

- When you select **Prepare to move**, any registered web services will be canceled. After moving your printer, set up your web services again.

➡ [Web service setup](#)

Firmware update

Important

- When you use this function, make sure the printer is connected to the Internet.
- The administrator password is required to change settings if it is enabled for changing settings using the operation panel.

Using Operation Panel



1. Select **Printer settings** on the HOME screen.
2. Select **Firmware update**.
If an administrator password is set, enter the password.
3. Select **Install update**.
4. Select **Yes**.
5. Check message and select **Start update**.

Using Remote UI

1. Start up Remote UI.
➔ [Start up Remote UI](#)
2. Select **Firmware update**.
3. Select **Install update**.
4. Check message and select **Update**.

Note

- If the firmware update is not complete, check the following and take an appropriate action.
 - Check the network settings such as a wireless router.
 - If **Cannot connect to the server**. is displayed on the touch screen, select **OK** and try again after a while.

Frequently Asked Questions

Problems with the Printing Quality



Unevenness, Banding, Faint

- ➔ [Printing is faint](#)
 - ➔ [Banding in different colors occurs](#)
 - ➔ [Colors in printed images are uneven](#)
 - ➔ [Image edges are blurred or white banding occurs](#)
-

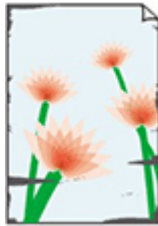

dirt

- ➔ [Paper rubs against the Print Head](#)
 - ➔ [The edges of the paper are dirty](#)
 - ➔ [The surface of the paper is dirty](#)
 - ➔ [The back side of the paper is dirty](#)
 - ➔ [Immediately after borderless printing, the trailing edge margin is soiled during regular printing](#)
-



colors are inaccurate

- ➔ [Printed colors are inaccurate](#)
- ➔ [Documents are printed in monochrome](#)



Line

- ➔ [Line thickness is not uniform](#)
- ➔ [Lines or colors are misaligned](#)

Others

- ➔ [The length of the printed image in the paper ejection direction is not accurate](#)
- ➔ [Images are printed crooked](#)
- ➔ [Margins are wide](#)
- ➔ [Borders appear in borderless printing](#)
- ➔ [When printing on roll paper, the printed surface becomes scratched](#)

General FAQ

- ➔ [The printer does not respond even if print jobs are sent](#)
- ➔ [Printing stops and an error message is displayed](#)
- ➔ [Failed to Printer Driver Installation \(Windows\)](#)
- ➔ [Removing Printer Software](#)

Search by Category

Cannot Configure Network Settings

- ➔ [Cannot Proceed beyond Printer Connection Screen/Connect Cable Screen](#)
- ➔ ["Failed to connect to the wireless router." Appears](#)
- ➔ [Taking Time to Setup Process \(Windows\)](#)

Cannot Find Printer on Network

- ➔ [Cannot Connect Printer to Network](#)
- ➔ [Cannot Find Printer During Setup](#)
- ➔ [Cannot Find Printer while Using Wi-Fi](#)
- ➔ [Cannot Find Printer while Using Wired LAN](#)
- ➔ [Searching Printer by IP Address or Host Name During Setup](#)

Cannot Print over Network

- ➔ [Cannot Print over TCP/IP Network](#)
- ➔ [Cannot Print over Bonjour networks](#)
- ➔ [Cannot Print Using AirPrint](#)

Network Connection Problems

- ➔ [Network Settings and Common Problems](#)
- ➔ [Cannot Connect to the Printer](#)

Printer Problems

- ➔ [Printer Does Not Turn On](#)
- ➔ [Messages advising to check the maintenance cartridge are not cleared](#)
- ➔ [The Data lamp on the Operation Panel does not light up](#)
- ➔ [If the Printer Makes a Strange Sound](#)
- ➔ [Printed pages are not collected cleanly in the basket](#)
- ➔ [Basket Lurches](#)
- ➔ [Warning Message is Displayed When Performing Color Calibration](#)

Paper is not Fed or Ejected Properly

- ➔ [Remove Jammed Roll Paper](#)
- ➔ [Remove a Jammed Sheet](#)
- ➔ [Roll paper cannot be inserted into the Paper Feed Slot](#)
- ➔ [Cannot load sheets](#)
- ➔ [Roll Paper Is not Fed Automatically](#)
- ➔ [Roll Paper Is not Switched Automatically](#)
- ➔ [Paper Source Does Not Switch When Roll Paper Is Used Up](#)
- ➔ [Roll Paper Remains/Lacks under Quantity Management](#)
- ➔ [The printer ejects blank, unprinted paper](#)

Paper Cutting Problems

- ➔ [Paper is not cut](#)
- ➔ [Paper is not cut straight](#)
- ➔ [Cutter Blade Does Not Work While Cutting Is in Progress](#)
- ➔ [I want to know how to configure roll cutting](#)
- ➔ [I want to configure so that the roll is cut automatically after waiting for the ink to dry](#)
- ➔ [When Trim edge first is set, the trimmed paper is drawn into the roll unit](#)

Paper Setting Problems

- ➔ [Paper widths with high transparency cannot be detected](#)
- ➔ [I want to know the paper types that can be used in this printer](#)
- ➔ [Estimated paper type does not match the loaded paper type](#)

- ➔ [The paper type that I want to print is not displayed on the Touch Screen](#)

Ink-related Problems

- ➔ [Printer consumes a lot of ink](#)
- ➔ [Ink Level Detection](#)
- ➔ [Does this printer support sub-ink tank system](#)

About Print Settings

- ➔ [How do I print without borders](#)
- ➔ [I want to easily create vertical or horizontal banners](#)
- ➔ [Can I perform duplex printing](#)
- ➔ [I want to perform enlargement printing](#)



The printer does not respond even if print jobs are sent



Check 1 Is **Pause printing** set to **Enable**?

Set **Pause printing** on the touch screen menu to **Disable**.

➔ [Pausing Printing](#)

Check 2 Is USB or LAN connection disabled?

- For USB connection:

Set **Use USB connection** on the touch screen menu to **Use**.

- For LAN connection (wired/Wi-Fi/Wireless Direct):

Set **Enable/disable Wired LAN**, **Enable/disable Wi-Fi**, or **Enable/disable Wireless Direct** on the touch screen menu to **Enable**.

➤➤➤ Note

- The printer cannot use a wired LAN connection simultaneously with a Wi-Fi or wireless direct connection.

Check 3 Is **Save to job box** selected as the printer **Output method**?

Print the job saved on the printer's hard disk.

➔ [Printing Saved Jobs](#)

Check 4 Is the print job pending?

Manage the jobs on hold and print as needed.

➔ [Printing Pending Jobs](#)



Printing stops and an error message is displayed



If the action indicated in the error message does not solve the problem, the roll paper may be stuck and not able to be advanced.

Check 1 Is the loaded roll paper touching printer parts, etc.?

If the loaded roll paper is touching printer parts, load the roll paper again.

- ➔ [Removing the Roll from the Printer](#)
- ➔ [Removing Roll Paper from the Roll Unit](#)

Check 2 Is the roll paper proper to use?

Check the outer diameter and paper thickness of the roll paper that can be used with your printer.

- ➔ [Paper Sizes](#)



Failed to Printer Driver Installation (Windows)



- If you cannot get past the Printer Connection screen:

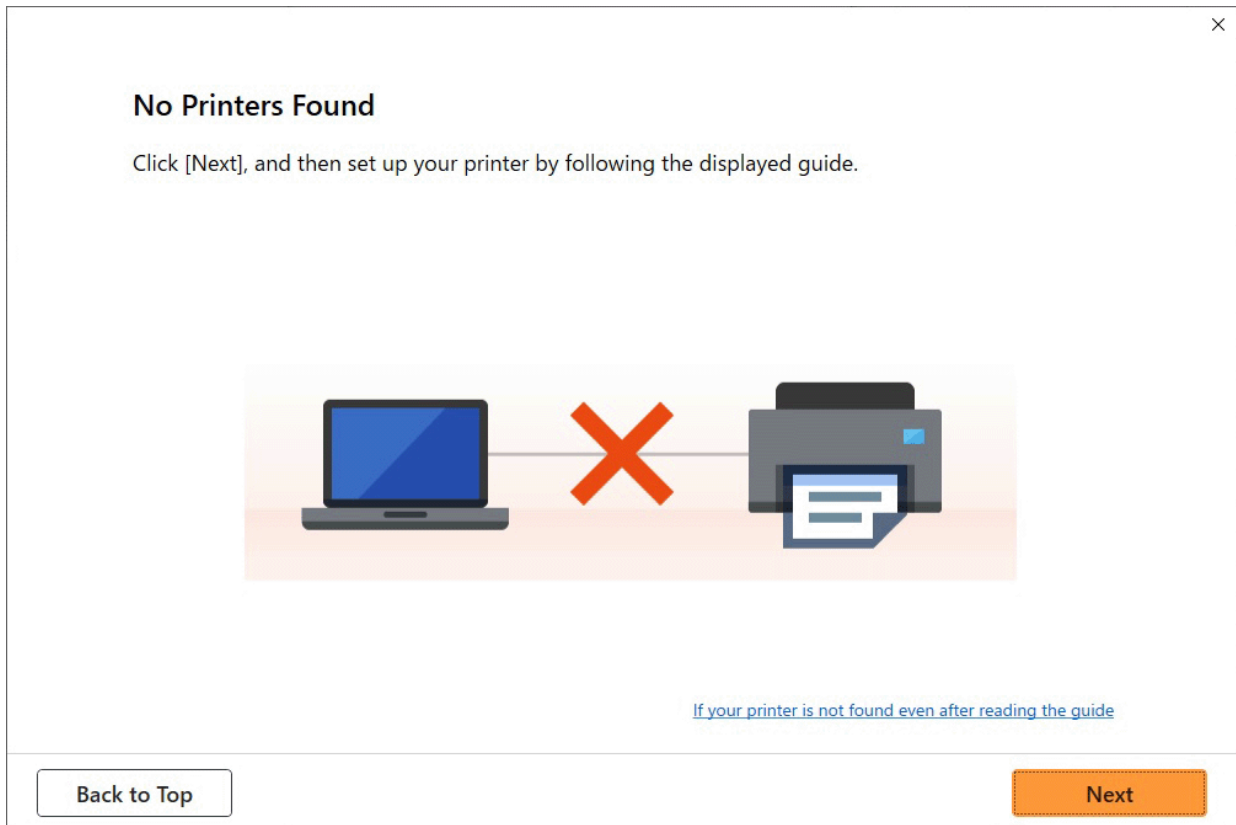

- ➔ [Cannot Proceed beyond Printer Connection Screen/Connect Cable Screen](#)

- **Other cases:**

Reinstall the printer driver.

If the printer driver was not installed correctly, uninstall the printer driver, restart your computer, and then reinstall the printer driver.

- ➔ Deleting the Unnecessary Printer Driver

Reinstall the printer driver with the Setup CD-ROM or install it from the Canon website.

▶▶▶ Note

- If the installer was stopped due to a Windows error, Windows operation may be unstable, and you may not be able to install the drivers. Restart your computer and then reinstall the drivers.



Removing Printer Software



Follow the steps below to remove utility software installed on the computer.

▶▶▶ Important

- You must log in as an administrator or have administrator permissions.

▶▶▶ Note

- See the pages below for how to remove printer drivers.
 - ➔ [Deleting the Unnecessary Printer Driver \(Windows\)](#)
 - ➔ [Delete the Unnecessary Canon IJ Printer from the Printer List](#) (macOS)

Removing the Wi-Fi Connection Assistant (Windows)

Follow the steps below to remove the Wi-Fi Connection Assistant.

- Windows 11

1. Click **Start**, and then select **Windows Tools** from **All Apps**.
2. Select **Control Panel**.
3. Under **Programs**, select **Programs and Features**, select Wi-Fi Connection Assistant from the list of programs, and then click **Uninstall**.

- Windows 10

1. Click **start**, select **Windows System**, and then select **Control Panel**.
2. Under **Programs**, select **Programs and Features**, select Wi-Fi Connection Assistant from the list of programs, and then click **Uninstall**.

- Windows 8.1

1. Use the **Settings** charm on the desktop to open the **Control Panel**.
2. Under **Programs**, select **Programs and Features**, select Wi-Fi Connection Assistant from the list of programs, and then click the **Uninstall** button.

- Windows 7

1. Select **Control Panel** from the **start** menu.

2. Select **Uninstall a program**.

3. Select Wi-Fi Connection Assistant, and then click the **Uninstall** button.

▶▶▶ **Note**

- If the **User Account Control** dialog box is displayed, click **Yes**.

Removing the Wi-Fi Connection Assistant (macOS)

Follow the steps below to remove the Wi-Fi Connection Assistant.

1. Select **Applications** from **Go** menu of Finder, double-click **Canon Utilities > Wi-Fi Connection Assistant**, and then drag **Canon Wi-Fi Connection Assistant** icon into **Trash**.

2. Restart computer.

Empty the **Trash** and restart your computer.

▶▶▶ **Note**

- To reinstall Wi-Fi Connection Assistant, uninstall Wi-Fi Connection Assistant and install it again from the Canon website.

Problems with the Printing Quality

- **Printing is faint**
- **Banding in different colors occurs**
- **Colors in printed images are uneven**
- **Image edges are blurred or white banding occurs**
- **Paper rubs against the Print Head**
- **The edges of the paper are dirty**
- **The surface of the paper is dirty**
- **The back side of the paper is dirty**
- **Immediately after borderless printing, the trailing edge margin is soiled during regular printing**
- **Printed colors are inaccurate**
- **Documents are printed in monochrome**
- **Line thickness is not uniform**
- **Lines or colors are misaligned**
- **The length of the printed image in the paper ejection direction is not accurate**
- **Images are printed crooked**
- **Margins are wide**
- **Borders appear in borderless printing**
- **When printing on roll paper, the printed surface becomes scratched**



Printing is faint



Check 1 Is the reverse side of the paper being used for printing?

Print on the printing surface.

Check 2 Is the Print head nozzle blocked?

Print a test pattern to check the nozzles and see if they are clogged.

➔ [Checking for Nozzle Clogging](#)

▶▶▶ Note

- To automatically check for nozzle blockages after printing, set **Auto nozzle check** in the touch screen menu to a setting other than **Disable**.

To show warnings based on nozzle check results, set **Nozzle check error display** in the touch screen menu to **Enable**.

However, printing may be stopped by warnings if this setting is set to **Enable**.

➔ [Auto maintenance settings](#)

Check 3 Was the printer left with the ink tank out?

The ink supply may become blocked by ink if the ink tank is left out.

If this happens, leave the printer for at least 24 hours with the ink tank in, and then carry out **Print Head Cleaning**.

➔ [Cleaning the Print Head](#)

Check 4 Are paper scraps stuck in the printer?

Remove paper scraps left inside the printer.

➔ [Remove Jammed Roll Paper](#)

➔ [Remove a Jammed Sheet](#)

Check 5 Was the paper cut before the ink dried?

In the touch screen menu, select **Paper-related settings** > **Advanced paper settings**, and increase time in **Pause between scans** or **Pause between pages**.

➔ [Specifying the Ink Drying Time](#)

Check 6 When printing photos and posters, are the **Print Target** settings set correctly?

In the printer driver, change the setting to **Photo (Color)** or **Poster** in **Print Target**.

➔ [Printing By Setting Print Purpose](#)

Check 7 Is the printer driver **Print Quality** set to a low quality setting?

Follow the steps below to set **Print Quality** to higher quality settings, and then print.

- Windows

Change the **Print Quality** settings in the printer driver **Advanced Settings**.

➔ [Changing the Print Quality and Correcting Image Data \(Windows\)](#)

- macOS

Change the **Print Quality** in the printer driver **Quality & Media** settings.

➔ [Changing the Print Quality and Correcting Image Data \(macOS\)](#)

Check 8 Does the paper used for printing create a lot of cutting dust?

In the touch screen menu, set **Cut-dust reduction** in **Advanced paper settings** to **ON**.

➔ [Reducing Dust from Cutting Rolls](#)



Banding in different colors occurs



Check 1 Make sure that the Print head nozzle is not blocked

Print a test pattern to check the nozzles and see if they are clogged.

➔ [Checking for Nozzle Clogging](#)

▶▶▶ Note

- To automatically check for nozzle blockages after printing, set **Auto nozzle check** in the touch screen menu to a setting other than **Disable**.

To show warnings based on nozzle check results, set **Nozzle check error display** in the touch screen menu to **Enable**.

However, printing may be stopped by warnings if this setting is set to **Enable**.

➔ [Auto maintenance settings](#)

Check 2 Does the paper loaded on the printer match the media type selected in the printer driver?

When printing with the media type specified in the printer driver, load the specified media type in the printer.

- ➔ [Loading Rolls in the Printer](#)
- ➔ [Loading Roll Paper in the Roll Unit](#)
- ➔ [Loading Sheets in the Printer](#)

When printing with the media type loaded in the printer, specify the media type in the printer driver.

- ➔ [Printing with Easy Setup \(Windows\)](#)
- ➔ [Printing with Easy Setup \(macOS\)](#)

▶▶▶ Note

- When **Auto (Use Printer Settings)** is selected for the media type, printing is performed with the media type loaded in the printer.

- Click **Get Information** to reflect the paper information set in the printer to the printer driver.

Check 3 Does the paper loaded on the printer match the media type selected on the touch screen?

Set the correct media type on the touch screen.

- ➔ [Changing the Type of Paper](#)

Check 4 Has the paper feed rate been calibrated properly?

Adjust the feed amount.

- ➔ [Automatically Adjusting Different Colored Horizontal Streaks](#)
- ➔ [Adjusting Line Length](#)

Check 5 When printing photos and posters, are the **Print Target** settings set correctly?

In the printer driver, change the setting to **Photo (Color)** or **Poster** in **Print Target**.

- ➔ [Printing By Setting Print Purpose](#)

Check 6 Low **Print Quality** setting causing lines in the printing

Follow the steps below to set **Print Quality** to the highest quality setting, and then print.

- Windows

Change the **Print Quality** settings in the printer driver **Advanced Settings**.

- ➔ [Changing the Print Quality and Correcting Image Data \(Windows\)](#)

- macOS

Change the **Print Quality** in the printer driver **Quality & Media** settings.

- ➔ [Changing the Print Quality and Correcting Image Data \(macOS\)](#)

Check 7 Is **Set priority** in the touch screen menu set to **Prioritize length accuracy**?

Setting **Set priority** to **Prioritize print quality** in **Paper feed adjustment** may improve the print quality.

- ➔ [Maintenance](#)

Check 8 Check if the Print head is in the right position

Adjust the Print head position.

- ➔ [Automatic Adjustment to Straighten Lines and Align Colors](#)

Check 9 Print job may have been interrupted while receiving, and therefore not printed at a fast frame rate

Exit other applications and cancel other print jobs.

Check 10 Make sure that lines are not printed around 100 mm from the paper edges.

If the printer is on standby or if you leave paper as it is for approximately over 30 minutes, paper may be curled or wrinkled.

Set **Sleep timer** on **Energy saving settings** to a value shorter than 30 minutes, so that you can prevent paper from being curled or wrinkled.

➔ [Other printer settings](#)



Colors in printed images are uneven



Check 1 Does the paper loaded on the printer match the media type selected in the printer driver?

When printing with the media type specified in the printer driver, load the specified media type in the printer.

- ➔ [Loading Rolls in the Printer](#)
- ➔ [Loading Roll Paper in the Roll Unit](#)
- ➔ [Loading Sheets in the Printer](#)

When printing with the media type loaded in the printer, specify the media type in the printer driver.

- ➔ [Printing with Easy Setup \(Windows\)](#)
- ➔ [Printing with Easy Setup \(macOS\)](#)

▶▶▶ Note

- When **Auto (Use Printer Settings)** is selected for the media type, printing is performed with the media type loaded in the printer.
- Click **Get Information** to reflect the paper information set in the printer to the printer driver.

Check 2 When loading paper in the printer, is the media loaded the same as the media type selected on the touch screen?

Set the correct media type on the touch screen.

- ➔ [Changing the Type of Paper](#)

Check 3 Is the Print head position adjusted correctly?

Adjust the Print head position.

- ➔ [Automatic Adjustment to Straighten Lines and Align Colors](#)

Check 4 Is the feed amount adjusted correctly?

Adjust feed amount.

- ➔ [Automatically Adjusting Different Colored Horizontal Streaks](#)
- ➔ [Adjusting Line Length](#)

Check 5 When printing photos and posters, are the **Print Target** settings set correctly?

In the printer driver, change the setting to **Photo (Color)** or **Poster** in **Print Target**.

- ➔ Printing By Setting Print Purpose

Check 6 Colors in printed images may be uneven if the **Print Quality** setting is too low

If using Windows, select **Advanced Settings** from the **Main** tab of the printer driver, and then select a higher **Print Quality** setting.

If using macOS, select **Quality & Media** in the printer driver, and then select a higher **Print Quality** setting.

- ➔ Changing the Print Quality and Correcting Image Data (Windows)
- ➔ [Changing the Print Quality and Correcting Image Data](#) (macOS)

Check 7 Are the Print Head nozzles clogged?

Check for nozzle clogging.

- ➔ [Checking for Nozzle Clogging](#)

Check 8 Colors in printed images may be uneven on the boundary between shades if there are dark and light areas in an image

Prints on the same page while switching between Bidirectional printing and Unidirectional printing. Therefore, color unevenness may occur when switching. Using the unidirectional printing function may reduce color unevenness in this situation.

Follow the steps below for unidirectional printing.

- Windows
Open **Paper Detailed Settings** from the **Main** tab of the printer driver, and then select **Unidirectional Printing**.
 - ➔ Main Tab Description
- macOS
Open **Advanced Paper Settings** in the printer driver, and then select **Unidirectional Printing**.
 - ➔ [Advanced Paper Settings](#)

Check 9 If printing borderless, colors in printed images may be a little uneven at the leading edge of the paper because printing is interrupted to cut the paper

Set the printer driver **Automatic Cutting** settings to **No**, and then print. Doing this prints only the left and right sides borderless. Cut the top and bottom borders with a cutting implement such as scissors after the printed materials are output and cut.

▶▶▶ Note

- Selecting a higher **Print Quality** in the printer driver **Advanced Settings** may resolve the problem.
 - ➔ Changing the Print Quality and Correcting Image Data (Windows)

➔ [Changing the Print Quality and Correcting Image Data](#) (macOS)

Check 10 Does this paper curl easily?

Colors in printed images may be uneven at the leading edge of paper that curls easily. Change the **Transport unit vacuum strength** in the touch screen to increase the grip on the paper, or set a margin of at least 0.8 inches (20 mm) at the front edge of the paper.

➔ [Adjusting Vacuum Strength](#)

Check 11 Color may be uneven if printing materials were stacked while drying

To avoid uneven colors, we recommend drying each sheet separately.

Check 12 Is Ink drying target area for **Pause between scans** in the touch screen menu set to **Leading edge**?

If the **Ink drying target area** for **Pause between scans** is set to **Leading edge**, color may be uneven approximately 7.5 inches (190 mm) from the front edge of the paper. (The position depends on the **Print Quality** settings)



On the HOME screen of the touch screen, select **Printer settings > Paper-related settings > Advanced paper settings > Pause between scans > Ink drying target area** and set to **Overall**.

However, note that printing will now take longer.

➔ [Specifying the Ink Drying Time](#)

Check 13 Make sure you are not printing cut sheet with AirPrint (macOS)

When you print cut sheets with AirPrint, uneven or streaked colors may occur at the trailing edge of the sheet. To print cut sheets with AirPrint. From the touch screen menu, tap **Printer settings > Paper-related settings > Keep margin at cut sheet end**.

➔ [Paper-related settings](#)

➤➤➤ Note

- Set **Keep margin at cut sheet end** to **Enable** to increase the margin at the trailing edge of the sheet.



Image edges are blurred or white banding occurs



Check 1 Paper may be gripped too strongly over the platen.

Set a lower **Transport unit vacuum strength** in the touch screen menu.

➔ [Adjusting Vacuum Strength](#)

Check 2 Check if the Print head is in the right position.

For detailed printing of small text or fine lines on glossy or semi-gloss photo paper etc., adjust the position of the Print head.

➔ [Automatic Adjustment to Straighten Lines and Align Colors](#)

Setting a lower value for **Head height** in the touch screen menu may resolve the problem.

➔ [Changing the Print Head Height](#)

Check 3 Does the paper loaded on the printer match the media type selected in the printer driver?

When printing with the media type specified in the printer driver, load the specified media type in the printer.

- ➔ [Loading Rolls in the Printer](#)
- ➔ [Loading Roll Paper in the Roll Unit](#)
- ➔ [Loading Sheets in the Printer](#)

When printing with the media type loaded in the printer, specify the media type in the printer driver.

- ➔ [Printing with Easy Setup \(Windows\)](#)
- ➔ [Printing with Easy Setup \(macOS\)](#)

▶▶▶ Note

- When **Auto (Use Printer Settings)** is selected for the media type, printing is performed with the media type loaded in the printer.

- Click **Get Information** to reflect the paper information set in the printer to the printer driver.

Check 4 When loading paper in the printer, is the media loaded the same as the media type selected on the touch screen?

Set the correct media type on the touch screen.

➔ [Changing the Type of Paper](#)

Check 5 Are the Print Head nozzles clogged?

Perform print head cleaning.

➔ [Cleaning the Print Head](#)



Paper rubs against the Print Head



Check 1 Does the paper loaded on the printer match the media type selected in the printer driver?

When printing with the media type specified in the printer driver, load the specified media type in the printer.

- ➔ [Loading Rolls in the Printer](#)
- ➔ [Loading Roll Paper in the Roll Unit](#)
- ➔ [Loading Sheets in the Printer](#)

When printing with the media type loaded in the printer, specify the media type in the printer driver.

- ➔ [Printing with Easy Setup \(Windows\)](#)
- ➔ [Printing with Easy Setup \(macOS\)](#)

▶▶▶ Note

- When **Auto (Use Printer Settings)** is selected for the media type, printing is performed with the media type loaded in the printer.
- Click **Get Information** to reflect the paper information set in the printer to the printer driver.

Check 2 When loading paper in the printer, is the media loaded the same as the media type selected on the touch screen?

Set the correct media type on the touch screen.

- ➔ [Changing the Type of Paper](#)

Check 3 Is the paper loaded properly?

If not loaded properly, paper can buckle and rub against the Print head.

Reload the paper.

- ➔ [Loading Rolls in the Printer](#)
- ➔ [Loading Roll Paper in the Roll Unit](#)
- ➔ [Loading Sheets in the Printer](#)

Check 4 Is the Print head height set too low?

Set **Head height** in the touch screen menu to the value higher than the current one.

- ➔ [Changing the Print Head Height](#)

Check 5 Is the paper thick, or a type that curls easily or is prone to buckling after absorbing ink?

- If using paper-based printing material such as Heavyweight Coated Paper, set **Transport unit vacuum strength** in the touch screen menu to **Medium-strong** or **Strong**.
- If using film-based printing material such as CAD Tracing Paper, set the **Transport unit vacuum strength** in the touch screen menu to **Standard**, **Medium-strong**, or **Strong**.
- If using paper thinner than 0.004 inches (0.1 mm), set **Transport unit vacuum strength** in the touch screen menu to **Weak**.

If that does not resolve the problem, increase the **Head height** setting in the touch screen menu.

- ➔ [Adjusting Vacuum Strength](#)
- ➔ [Changing the Print Head Height](#)

Check 6 Does the paper have a strong curl at the front edge or is it buckled?

Set **Cutting mode** in the touch screen menu to **User cut**, and set leading edge detection to **Do not detect**.

To keep track of the amount of roll paper remaining, set **Manage remaining roll amount** to **Auto estimate** or **Disable** before loading the roll paper, and then restore the setting of **Manage remaining roll amount** to **Auto estimate** or **Barcodes** after the roll paper is loaded.

In addition, set **Media type selection method** to **Manual** or **Use current media type**.

- ➔ [Specifying the Cutting Method for Rolls](#)
- ➔ [Keeping Track of the Amount of Roll Paper Left](#)

Check 7 If you are using plain paper, changing the settings from the printer driver may improve the print results.

- For the **Easy Settings**
 - Set **Print Target** to **Photo (Color)** or **Poster**.
 - ➔ [Printing By Setting Print Purpose](#)

Check 8 If you are using rolls, are you using the recommended paper and recommended environment?

Using rolls or environments other than those recommended, may result in increased curl and rubbing of the print head. Use the recommended paper and recommended environment.

- ➔ [Paper Settings List \(Roll Paper\)](#)



The edges of the paper are dirty

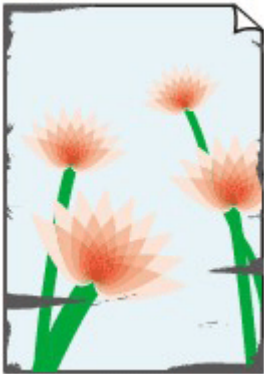

Check 1 Was printing borderless or on small paper?

The platen may become dirtied by borderless printing or on small paper sizes.

Open the top cover and clean the platen.

➔ [Cleaning Inside the Top Cover](#)

Check 2 Is **Extension for borderless printing** set to a large value?

The platen may become dirtied by setting a large amount of extension.

Reduce the value of **Extension for borderless printing**.

➔ [Specifying the Amount of Extension for Borderless Printing](#)

Check 3 Does the paper loaded on the printer match the media type selected in the printer driver?

The platen may become dirty if the loaded paper does not match the settings. We recommend that you clean the platen before printing again.

➔ [Cleaning Inside the Top Cover](#)

When printing with the media type specified in the printer driver, load the specified media type in the printer.

- ➔ [Loading Rolls in the Printer](#)
- ➔ [Loading Roll Paper in the Roll Unit](#)
- ➔ [Loading Sheets in the Printer](#)

When printing with the media type loaded in the printer, specify the media type in the printer driver.

- ➔ [Printing with Easy Setup \(Windows\)](#)
- ➔ [Printing with Easy Setup \(macOS\)](#)

»» Note

- When **Auto (Use Printer Settings)** is selected for the media type, printing is performed with the media type loaded in the printer.
- Click **Get Information** to reflect the paper information set in the printer to the printer driver.

Check 4 When loading paper in the printer, is the media loaded the same as the media type selected on the touch screen?

The platen may become dirty if the loaded paper does not match the settings. We recommend that you clean the platen before printing again.

➔ [Cleaning Inside the Top Cover](#)

Set the correct media type on the touch screen.

➔ [Changing the Type of Paper](#)

Check 5 Is the paper creased or curled?

Straighten out the wrinkles or curls and reload the paper.

➔ [Loading Rolls in the Printer](#)

➔ [Loading Roll Paper in the Roll Unit](#)

➔ [Loading Sheets in the Printer](#)

Check 6 In the touch screen menu, is **Cut-dust reduction** in **Advanced paper settings** set to **ON**?

A cut dust reduction line is printed at the paper cut position when **Cut-dust reduction** is set to **ON**.

If cutting dust reduction is not required, set **Cut-dust reduction** to **OFF**.

➔ [Reducing Dust from Cutting Rolls](#)

Check 7 Is the Print head height set too low in the touch screen menu?

Set **Head height** to the value higher than the current one.

➔ [Changing the Print Head Height](#)

Check 8 Is the paper thick, or a type that curls easily or is prone to buckling after absorbing ink?

- If using paper-based printing material such as thick-coat paper, set **Transport unit vacuum strength** in the touch screen menu to **Medium-strong** or **Strong**.
- If using film-based printing material such as tracing paper, set the **Transport unit vacuum strength** in the touch screen menu to **Standard**, **Medium-strong**, or **Strong**.

If that does not resolve the problem, increase the **Head height** setting in the touch screen menu.

➔ [Adjusting Vacuum Strength](#)

➔ [Changing the Print Head Height](#)

Check 9 Is the output guide clean?

Clean the output guide.

➔ [Cleaning Inside the Top Cover](#)

Check 10 If you are using plain paper, changing the settings from the printer driver may improve the print results.

- For the **Easy Settings**

Set **Print Target** to **Photo (Color)** or **Poster**.

➔ [Printing By Setting Print Purpose](#)

Check 11 If you are using rolls, are you using the recommended paper and recommended environment?

Using rolls or environments other than those recommended, may result in increased curl and rubbing of the print head. Use the recommended paper and recommended environment.

➔ [Paper Settings List \(Roll Paper\)](#)



The surface of the paper is dirty

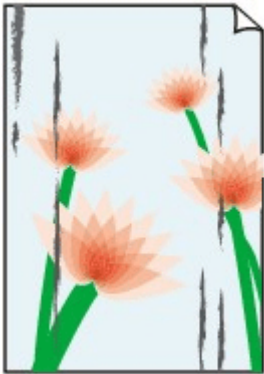

Check 1 Is the paper retainer clean?

Clean the paper retainer.

➔ [Cleaning Inside the Top Cover](#)

Check 2 If using plain papers, is the media type set to **Plain papers**?

Set the media type to **PlainP(Instant-dry)** for improved quick-drying.

➔ [Changing the Type of Paper](#)

Check 3 Does this paper take longer to dry?

Increase the length of the **Pause between pages** and **Pause between scans** settings from the touch screen menu.

➔ [Specifying the Ink Drying Time](#)

▶▶▶ Note

- When printing on paper that takes longer to dry, the paper may curl during printing and come in contact with the output tray.

In such situations, set an **Ink drying wait time** and an **Ink drying target area** for **Pause between scans** in the touch screen menu.

However, note that printing will now take longer.

- In a hot and humid environment, rolling paper printed with images containing areas of saturated color may transfer ink to the contact surface, affecting print quality.

Move the printer to a different environment, or let the paper dry before rolling it.

Check 4 Does the paper loaded on the printer match the media type selected in the printer driver?

The platen may become dirty if the loaded paper does not match the settings. We recommend that you clean the platen before printing again.

➔ [Cleaning Inside the Top Cover](#)

When printing with the media type loaded in the printer, specify the same media type in the printer driver.

➔ [Loading Rolls in the Printer](#)

➔ [Loading Roll Paper in the Roll Unit](#)

➔ [Loading Sheets in the Printer](#)

When printing with the media type loaded in the printer, specify the media type in the printer driver.

➔ Printing with Easy Setup (Windows)

➔ [Printing with Easy Setup](#) (macOS)

▶▶▶ Note

- When **Auto (Use Printer Settings)** is selected for the media type, printing is performed with the media type loaded in the printer.
- Click **Get Information** to reflect the paper information set in the printer to the printer driver.

Check 5 Does the paper type selected in the printer driver or on the touch screen match the actual paper type loaded?

The platen may become dirty if the loaded paper does not match the settings. We recommend that you clean the platen before printing again.

➔ [Cleaning Inside the Top Cover](#)

Set the correct paper type on the touch screen.

➔ [Changing the Type of Paper](#)

Check 6 Dirt may be removed by letting a blank sheet of paper pass through.

Perform a paper feed from the touch screen.

➔ [Feeding Roll Paper Manually](#)

Check 7 If you are using plain paper, changing the settings from the printer driver may improve the print results.

- For the **Easy Settings**

Set **Print Target** to **Photo (Color)** or **Poster**.

➔ Printing By Setting Print Purpose

Check 8 If you are using rolls, are you using the recommended paper and recommended environment?

Using rolls or environments other than those recommended, may result in increased curl and rubbing of the print head. Use the recommended paper and recommended environment.

➔ Paper Settings List (Roll Paper)



The back side of the paper is dirty

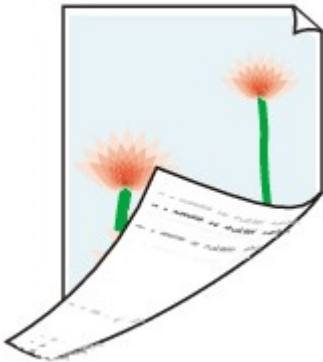

Check 1 Was the previous print job borderless, or printed on small paper?

Open the top cover and clean the platen.

➔ [Cleaning Inside the Top Cover](#)

Check 2 Is **Detect paper width** in the touch screen menu set to **Disable**?

Printing with **Detect paper width** set to **Disable** may cause the platen to be dirtied.

Set **Detect paper width** in the touch screen menu to **Enable**, and then open the top cover and clean the platen.

To continue printing with **Detect paper width** set to **Disable**, first open the top cover and clean the platen, and then manually feed roll paper over the platen when printing.

➔ [Cleaning Inside the Top Cover](#)

➔ [Feeding Roll Paper Manually](#)

Check 3 Paper may be gripped weakly over the platen.

Set a higher **Transport unit vacuum strength** in the touch screen menu.

➔ [Adjusting Vacuum Strength](#)

Check 4 Is **Extension for borderless printing** set to a large value?

The platen may become dirtied by setting a large amount of extension.

Reduce the value of **Extension for borderless printing**.

➔ [Specifying the Amount of Extension for Borderless Printing](#)

Check 5 If using plain papers, is the media type set to **Plain papers**?

Set the media type to **PlainP(Instant-dry)** for improved quick-drying.

➔ [Changing the Type of Paper](#)

Check 6 Does this paper take longer to dry?

Increase the length of the **Pause between pages** and **Pause between scans** settings from the touch screen menu.

➔ [Specifying the Ink Drying Time](#)

If the platen is dirty, open the top cover and clean the platen.

➔ [Cleaning Inside the Top Cover](#)

▶▶▶ Note

- When printing on paper that takes longer to dry, the paper may curl during printing and come in contact with the output tray.

In such situations, set an **Ink drying wait time** and an **Ink drying target area** for **Pause between scans** in the touch screen menu.

However, note that printing will now take longer.

- In a hot and humid environment, rolling paper printed with images containing areas of saturated color may transfer ink to the contact surface, affecting print quality.

Move the printer to a different environment, or let the paper dry before rolling it.

Check 7 Does the paper loaded on the printer match the media type selected in the printer driver?

The platen may become dirty if the loaded paper does not match the settings. We recommend that you clean the platen before printing again.

➔ [Cleaning Inside the Top Cover](#)

When printing with the media type specified in the printer driver, load the specified media type in the printer.

➔ [Loading Rolls in the Printer](#)

➔ [Loading Roll Paper in the Roll Unit](#)

➔ [Loading Sheets in the Printer](#)

When printing with the media type loaded in the printer, specify the media type in the printer driver.

➔ [Printing with Easy Setup \(Windows\)](#)

➔ [Printing with Easy Setup \(macOS\)](#)

▶▶▶ Note

- When **Auto (Use Printer Settings)** is selected for the media type, printing is performed with the media type loaded in the printer.
- Click **Get Information** to reflect the paper information set in the printer to the printer driver.

Check 8 Does the paper type selected in the printer driver or on the touch screen match the actual paper type loaded?

The platen may become dirty if the loaded paper does not match the settings. We recommend that you clean the platen before printing again.

➔ [Cleaning Inside the Top Cover](#)

Set the correct paper type on the touch screen.

➔ [Changing the Type of Paper](#)

Check 9 Dirt may be removed by letting a blank sheet of paper pass through.

Perform a paper feed from the touch screen.

➔ [Feeding Roll Paper Manually](#)



Immediately after borderless printing, the trailing edge margin is soiled during regular printing



In some situations, borderless printing with automatic cutting of the leading and trailing edges on roll paper may transfer ink on the cutter blade to the next item printed.

Use **Pause between pages** on the touch screen to change the ink drying time to between 30 seconds and 3 minutes before performing borderless printing.

➔ [Specifying the Ink Drying Time](#)



Printed colors are inaccurate



Check 1 Is the Print head nozzle blocked?

Print a test pattern to check the nozzles and see if they are clogged.

➔ [Checking for Nozzle Clogging](#)

Check 2 When printing photos and posters, are the **Print Target** settings set correctly?

In the printer driver, change the setting to **Photo (Color)** or **Poster** in **Print Target**.

➔ [Printing By Setting Print Purpose](#)

Check 3 Has color been adjusted in the printer driver?

Follow the steps below to adjust color settings.

- Windows

Adjust the color settings with **Color Mode > Color Settings** in **Advanced Settings** in the printer driver.

➔ [Main Tab Description \(Windows\)](#)

- macOS

Adjust the color settings in the printer driver **Color Options**.

➔ [Color Options \(macOS\)](#)

Check 4 Is **Application Color Matching Priority** set to **Off** in a Windows printer driver?

In the printer driver **Layout** sheet, click **Special Settings**, and then set **Application Color Matching Priority** to **On** in the dialog box that appears.

➔ [Layout Tab Description \(Windows\)](#)

Check 5 Has the computer or monitor color been adjusted?

Take the actions below.

- Refer to the computer and monitor documentation to adjust the colors.
- Adjust the settings of the color management software, referring to the software documentation as needed.

Check 6 Has the Print head been replaced?

Differences between one Print head and another may result in a change in color after replacing the Print head.

Execute color calibration.

➔ [Performing Color Calibration](#)

Check 7 The Print head characteristics may have changed.

The characteristics of a Print head may change with repeated use, including color.

Execute color calibration.

➔ [Performing Color Calibration](#)

Check 8 Color varies even between printers of the same model due to differences in firmware and printer driver versions, settings, or environment.

Follow these steps to prepare the printing environment.

1. Use the same version of firmware or printer driver.
2. Specify the same value for all settings items.
3. Execute color calibration.

➔ [Performing Color Calibration](#)

Check 9 Did you make a different selection in Select Your Place of Residence in the Media Configuration Tool when reinstalling the printer driver?

Changing the region selection of the Media Configuration Tool deletes the region-specific paper information originally registered on the printer before installation. Using paper with deleted information when executing color calibration will prevent the resulting calibration adjustment value from being applied to all other types of the paper.

Prepare paper compatible with calibration in the newly selected region and perform calibration again.

➔ [Performing Color Calibration](#)



Documents are printed in monochrome



Check 1 Is **Color Mode** set to **Monochrome**, or is **Print Target** set to **Photo (Monochrome)** in a Windows printer driver?

In the **Advanced Settings** of the printer driver, specify **Color** in **Color Mode** and try printing again.

➔ [Main Tab Description \(Windows\)](#)

Check 2 Is **Black and White Photo Print** selected in a macOS printer driver?

Deselect **Black and White Photo Print** in the printer driver **Quality & Media** settings, and then print again.

➔ [Quality & Media \(macOS\)](#)

Check 3 The print head nozzle may be blocked

Print a test pattern to check the color ink nozzles and see if they are clogged.

➔ [Checking for Nozzle Clogging](#)



Line thickness is not uniform



Check 1 Does the paper loaded on the printer match the media type selected in the printer driver?

When printing with the media type specified in the printer driver, load the specified media type in the printer.

- ➔ [Loading Rolls in the Printer](#)
- ➔ [Loading Roll Paper in the Roll Unit](#)
- ➔ [Loading Sheets in the Printer](#)

When printing with the media type loaded in the printer, specify the media type in the printer driver.

- ➔ [Printing with Easy Setup \(Windows\)](#)
- ➔ [Printing with Easy Setup \(macOS\)](#)

▶▶▶ Note

- When **Auto (Use Printer Settings)** is selected for the media type, printing is performed with the media type loaded in the printer.
- Click **Get Information** to reflect the paper information set in the printer to the printer driver.

Check 2 When loading paper in the printer, is the media loaded the same as the media type selected on the touch screen?

Set the correct media type on the touch screen.

- ➔ [Changing the Type of Paper](#)

Check 3 Adjust the position of the Print head

If the printed result does not look uniform, such as when the lines are misaligned, adjust the position of Print Head.

➔ [Automatic Adjustment to Straighten Lines and Align Colors](#)

For photo paper and proof paper, it may be improved by setting **Head height** to a value lower than the current setting and then adjust the position of the Print head.

➔ [Changing the Print Head Height](#)

Check 4 Is **Fast Graphic Process** set to **On** in the 32-bit Windows printer driver **Special Settings** dialog box?

Access the printer driver **Properties** dialog box from **Print** in the **File** menu of the source application, and follow these steps to print.

1. Deselect **Preview before printing** in the **Main** sheet.
2. Deselect **Page Layout** in the **Layout** sheet.
3. Click the **Special Settings** button in the **Layout** sheet, and then set **Fast Graphic Process** to **Off** in the **Special Settings** dialog box that opens.



Lines or colors are misaligned



Check 1 Adjust the position of the Print head

If borders are misaligned or the print results are not uniform, adjust the position of the Print head.

- ➔ [Automatic Adjustment to Straighten Lines and Align Colors](#)

For photo paper and proof paper, it may be improved by setting **Head height** to a value lower than the current setting and then adjust the position of the Print head.

- ➔ [Changing the Print Head Height](#)

Check 2 Does the paper loaded on the printer match the media type selected in the printer driver?

When printing with the media type specified in the printer driver, load the specified media type in the printer.

- ➔ [Loading Rolls in the Printer](#)
- ➔ [Loading Roll Paper in the Roll Unit](#)
- ➔ [Loading Sheets in the Printer](#)

When printing with the media type loaded in the printer, specify the media type in the printer driver.

- ➔ [Printing with Easy Setup \(Windows\)](#)
- ➔ [Printing with Easy Setup \(macOS\)](#)

▶▶▶ Note

- When **Auto (Use Printer Settings)** is selected for the media type, printing is performed with the media type loaded in the printer.
- Click **Get Information** to reflect the paper information set in the printer to the printer driver.

Check 3 When loading paper in the printer, is the media loaded the same as the media type selected on the touch screen?

Set the correct media type on the touch screen.

- ➔ [Changing the Type of Paper](#)

Check 4 Is the Roll Paper loaded at an angle?

If there is a gap between the roll paper and the roll holder, reload the roll paper.

➔ [Loading Rolls on the Roll Holder](#)

Check 5 Paper may have been fed at an angle.

When **Roll paper auto feed** is set to **Disable**, feed the roll paper into the printer so that there is no gap between the right edge of the roll paper and the roll holder.

➔ [Loading Rolls in the Printer](#)

➔ [Loading Roll Paper in the Roll Unit](#)

Check 6 Is **Detect paper width** set to **Disable**?

Set **Detect paper width** in the touch screen menu to **Enable** to load the paper.

➔ [Advanced \(Paper settings\)](#)

Check 7 Is **Skew detection accuracy** in the touch screen menu set to **Loose** or **OFF**?

Set **Skew detection accuracy** to **Standard**, and then reload the paper.

➔ [Advanced \(Paper settings\)](#)

Check 8 If you are using rolls, are you using the recommended paper and recommended environment?

Using rolls or environments other than those recommended, may result in increased curl and rubbing of the print head. Use the recommended paper and recommended environment.

➔ Paper Settings List (Roll Paper)

Check 9 Colors in printed images may be uneven if the **Print Quality** setting is too low

If using Windows, select **Advanced Settings** from the **Main** tab of the printer driver, and then select a higher **Print Quality** setting.

If using macOS, select **Quality & Media** in the printer driver, and then select a higher **Print Quality** setting.

➔ [Changing the Print Quality and Correcting Image Data \(Windows\)](#)

➔ [Changing the Print Quality and Correcting Image Data \(macOS\)](#)

Check 10 Is **Unidirectional printing** set to **Disable**?

Using the Unidirectional printing function may reduce the shift of ruled lines. Follow the steps below for unidirectional printing.

- Windows

Open **Paper Detailed Settings** from the **Main** tab of the printer driver, and then select **Unidirectional Printing**.

➔ Main Tab Description

- macOS

Open **Advanced Paper Settings** in the printer driver, and then select **Unidirectional Printing**.

➔ [Advanced Paper Settings](#)



The length of the printed image in the paper ejection direction is not accurate

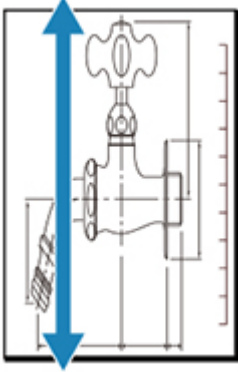

Check 1 Does the paper loaded on the printer match the media type selected in the printer driver?

When printing with the media type specified in the printer driver, load the specified media type in the printer.

- ➔ [Loading Rolls in the Printer](#)
- ➔ [Loading Roll Paper in the Roll Unit](#)
- ➔ [Loading Sheets in the Printer](#)

When printing with the media type loaded in the printer, specify the media type in the printer driver.

- ➔ Printing with Easy Setup (Windows)
- ➔ [Printing with Easy Setup](#) (macOS)

▶▶▶ Note

- When **Auto (Use Printer Settings)** is selected for the media type, printing is performed with the media type loaded in the printer.
- Click **Get Information** to reflect the paper information set in the printer to the printer driver.

Check 2 When loading paper in the printer, is the media loaded the same as the media type selected on the touch screen?

Set the correct media type on the touch screen.

- ➔ [Changing the Type of Paper](#)

Check 3 Perform print quality adjustment to automatically adjust the feed amount.

Perform **Adjust print quality** from **Paper feed adjustment** and **Print alignment pattern** to automatically adjust the feed amount.

- ➔ [Automatically Adjusting Different Colored Horizontal Streaks](#)

Check 4 Is **Set priority** for **Paper feed adjustment** in the touch screen menu set to **Prioritize print quality**?

Set priority for **Paper feed adjustment** to **Prioritize length accuracy**, and then carry out **Adjust feed length**.

- ➔ [Maintenance](#)
- ➔ [Adjusting Line Length](#)



Images are printed crooked



Check 1 Has the roll paper been loaded at an angle?

If there is a gap between the roll paper and roll holder, reload the roll on the roll holder.

➔ [Loading Rolls on the Roll Holder](#)

Check 2 Paper may have been fed at an angle.

When **Roll paper auto feed** is set to **Disable**, feed the roll paper into the printer so that there is no gap between the right edge of the roll paper and the roll holder.

➔ [Loading Rolls in the Printer](#)

➔ [Loading Roll Paper in the Roll Unit](#)

Check 3 Is **Detect paper width** set to **Disable**?

Set **Detect paper width** in the touch screen menu to **Enable** to load the paper.

➔ [Advanced \(Paper settings\)](#)

Check 4 Is **Skew detection accuracy** in the touch screen menu set to **Loose** or **OFF**?

Set **Skew detection accuracy** to **Standard**, and then reload the paper.

➔ [Advanced \(Paper settings\)](#)



Margins are wide



Check 1 Is auto cut being used on printed material with a wide margin on the trailing edge only?

Rolls are advanced a specific amount before cutting to prevent problems with cutting and paper ejection.

This operation is normal.

The specified length varies depending on the media type and the usage environment (humidity). Please refer to the minimum printing length of the paper from paper information list.

If the length of the printed document is shorter than the minimum cut length, an extra edge margin will be added to increase the length of the printed document to the minimum cut length.

➔ [Paper Settings List \(Roll Paper\)](#)

Check 2 Is leading edge detection set to **Do not detect**?

Do not detect may have been set by responding to the message **Do you want to set to detect the leading edge of the paper?** when **Cutting mode** was set to **User cut** in the touch screen menu.

If the message **Do you want to set to detect the leading edge of the paper?** appears when setting **Cutting mode** to **User cut**, select **Detect (recommended)**.

Please note that if **Detect (recommended)** is selected and the paper has a strong curl, the Print head may rub against the edge of the paper when printing starts.

➔ [Specifying the Cutting Method for Rolls](#)



Borders appear in borderless printing

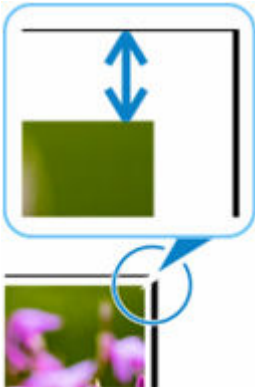

If white bandings or borders appear on the edges of borderless printing, check the following items.

Check 1 Is the position of the Print head adjusted?

Adjusting the position of the Print head will improve the printing accuracy.

➔ [Automatic Adjustment to Straighten Lines and Align Colors](#)

Check 2 If printing full-scale borderless, is the selected paper wider than the source size?

For borderless printing at actual size, use roll paper that has the same width as the actual page size.

➔ [Printing Full-Size without Margins \(Windows\)](#)

➔ [Printing Full-Size without Margins \(macOS\)](#)

Check 3 Does the source file have margins?

Check that the printing image data does not have any objects like crop marks and transparent objects.

Check 4 Is a margin set in application software?

Check that no margins are configured in the application software you are using.

Check 5 Is the **Extension for borderless printing** set to large in the touch screen menu?

In the touch screen menu, set **Extension for borderless printing** to the smaller number than the current setting.

➔ [Specifying the Amount of Extension for Borderless Printing](#)



When printing on roll paper, the printed surface becomes scratched



Check 1 Depending on the paper, the printed surface may become scratched when the paper is fed.

In this case, you must set **Paper retention settings** to **Release** on the touch screen, and then manually feed the paper. Lift the release lever, feed the roll paper until the leading edge is visible on the platen, lower the release lever, and then proceed to the next step.

If **Paper retention settings** is set to **Release**, you will no longer be able to automatically switch between the upper and lower roll paper.

Check 2 Has the roll paper lost tension during printing?

If the roll paper loses tension, the paper surface could be damaged and the paper could wrinkle or fold.

Set **Roll paper tension (printing)** to **High** in the touch screen menu.

➔ [Advanced \(Paper settings\)](#)

▶▶▶ Note

- Carrying out **Adjust print quality** is recommended when changing **Roll paper tension (printing)** settings.
➔ [Automatically Adjusting Different Colored Horizontal Streaks](#)

Cannot Configure Network Settings

- **Cannot Proceed beyond Printer Connection Screen/Connect Cable Screen**
- **"Failed to connect to the wireless router." Appears**
- **Taking Time to Setup Process (Windows)**



Cannot Proceed beyond Printer Connection Screen/Connect Cable Screen



If you cannot proceed beyond the **Printer Connection** screen or the **Connect Cable** screen, check the following.

Check 1 Make sure USB cable is securely plugged in to printer and computer.

Connect the printer and the computer using a USB cable as the illustration below. The USB port is located on the back of the printer.

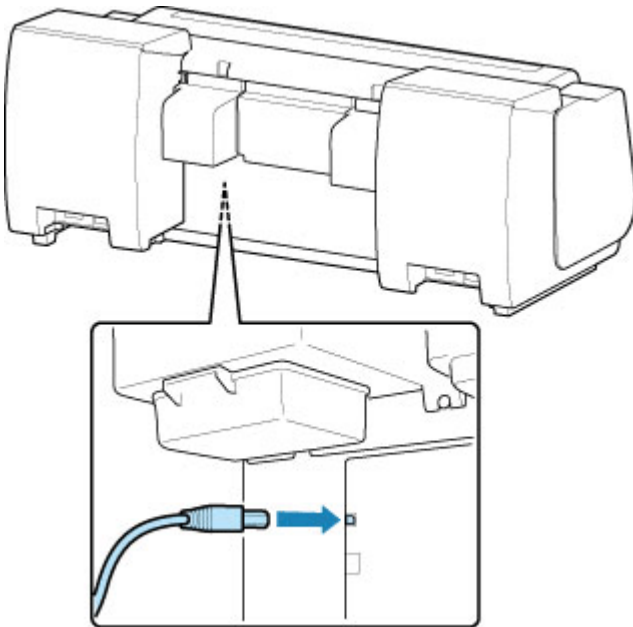

Check the items below only if you cannot proceed beyond the Printer Connection screen.

Check 2 Follow procedure below to connect printer and computer again.

▶▶▶ Important

- For macOS, make sure the lock icon is on the lower left of the **Printers & Scanners** screen.



If the  icon (locked) is displayed, click the icon to unlock. (The administrator name and the password are necessary to unlock.)

1. Turn off printer.
2. Unplug USB cable from printer and computer and connect it again.

3. Turn on printer.

Check 3 If you cannot resolve problem, follow procedure below to reinstall printer driver.

1. Exit setup.

2. Turn off printer.

3. Restart computer.

4. Make sure you have no application software running.

5. Refer to Setup Guide for setup.



"Failed to connect to the wireless router." Appears



Each time you perform each check, select **OK** on the error screen to clear the error and set up the printer again.

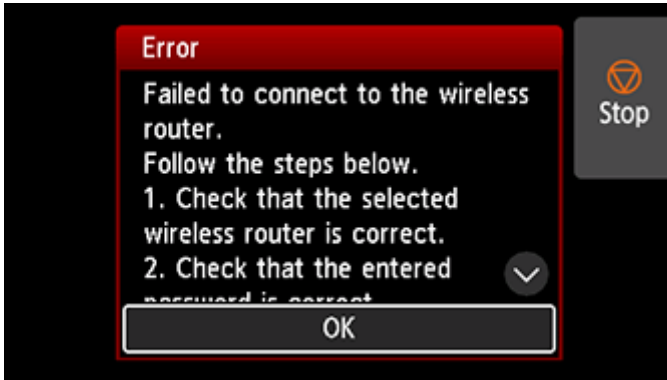

➔ [When Security Type is WPA/WPA2/WPA3](#)

➔ [When Security Type is set to Disable](#)

When Security Type is WPA/WPA2/WPA3

Check 1 Check the password entered for the wireless router is correct.

If the password you entered is incorrect, enter the correct password.

Check 2 Check the wireless router's settings.

If the wireless router's DHCP function is off, turn it on and redo the wireless connection settings.

Check 3 Check the MAC address filtering's settings.

If MAC address filtering is enabled on the wireless router, change the settings to accept the printer's MAC address.

The MAC address of the printer can be viewed from **Printer information > System information**.

➔ [Printer information](#)

Check 4 Check the wireless router's security protocol (encryption method) settings.

If the wireless router is set to communicate using the IEEE802.11n standard only and encryption is set to TKIP, change the encryption standard to something other than TKIP or change the communication standard, and then redo the wireless connection settings.

If the encryption standard is set to TKIP, IEEE802.11n cannot be used as the communication standard.

For details on changing the wireless router settings, see the wireless router manual or contact its manufacturer.

When Security Type is set to Disable

Check Is the wireless router turned on?

If it is already turned on, turn it off, and then turn it back on.

Do not proceed to the next screen of this guide until the power is turned on. The connection to the wireless router will be temporarily disabled.



Taking Time to Setup Process (Windows)



If Windows update starts during setup, or if you perform setup while Windows update is in progress, it may take a while to register the printer or to perform other processes.

Wait for a while. This is not a malfunction.

Cannot Find Printer on Network

- **Cannot Connect Printer to Network**
- **Cannot Find Printer During Setup**
- **Cannot Find Printer while Using Wi-Fi**
- **Cannot Find Printer while Using Wired LAN**
- **Searching Printer by IP Address or Host Name During Setup**



Cannot Connect Printer to Network



Check 1 Is the Ethernet cable connected correctly to the printer's wired LAN connector?

Make sure the printer is connected to the network with the correct Ethernet cable, and then turn the printer on. For instructions on connecting the cable, refer to the Setup Guide.

Check 2 Make sure the Link indicator is lit.

When the printer is connected via 1000Base-T, both the top and bottom indicators are lit.

When the printer is connected via 100Base-TX, the top indicator will light green. For 10Base-T connections the lower indicator will light orange.

If the Link indicator is not lit, check the following points.

- The hub is on.
- The end of the Ethernet cable is connected correctly.

Insert the Ethernet cable until it clicks and locks in place.

- There is no problem with the Ethernet cable.

If there is any problem, replace the Ethernet cable.

Cannot Find Printer During Setup

If you cannot find the printer on network during setup, check the following.

No Printers Found

Click [Next], and then set up your printer by following the displayed guide.

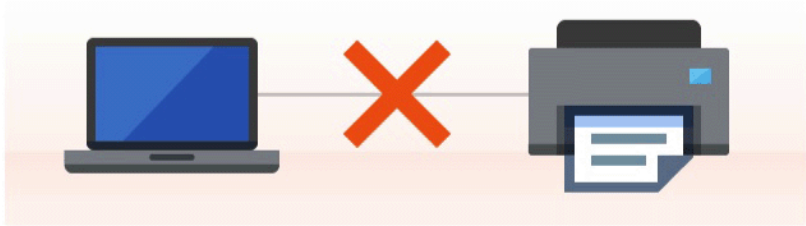

[If your printer is not found even after reading the guide](#)

Back to Top Next

When you complete all the checking, try to set up from the beginning.

Items to check for Wi-Fi

Step 1 Check the basic items for Wi-Fi

1. Check power status

Are printer and network device (router, etc.) turned on?

Stop setting up, and check if the router (modem) is turned on and then check if the printer is turned on.

1. Check if network devices such as router are turned on.

If network devices are not turned on, turn on the power. If the network devices are on, turn them off and on again.

It may take a while for the network device to become ready for use once they are turned on.

Proceed once the network devices such as router are ready for use.

2. Check if the printer is turned on

If printer is not turned on, turn on the power. If the printer is on, turn them off and on again.

2. Check PC network connection

Can you view any web pages on your computer? Make sure the computer and network device (wireless router, etc.) are configured and the computer is connected to the network.

If you cannot view web pages on your computer, check wireless router network connection settings, such as IP address filtering, MAC address filtering, and DHCP function.

For more on checking the settings of the wireless router, refer to the instruction manual supplied with the wireless router or contact the manufacturer.

▶▶▶ Important

- Depending on the wireless router, note that different network name (SSID) is assigned for a bandwidth (2.4 GHz or 5 GHz) or its usage (for PC or game machine), using alphanumeric characters at the end of network name (SSID).

Once you complete checking the wireless router, configure the network settings for your computer. For the procedures, refer to the instruction manual supplied with the computer, or contact the manufacturer.

Once you complete setting up the wireless router and your computer, configure the settings on your computer in order to view web pages, using the information of the wireless router.

3. Check printer's Wi-Fi settings

Make sure the  or  icon is displayed on the touch screen.

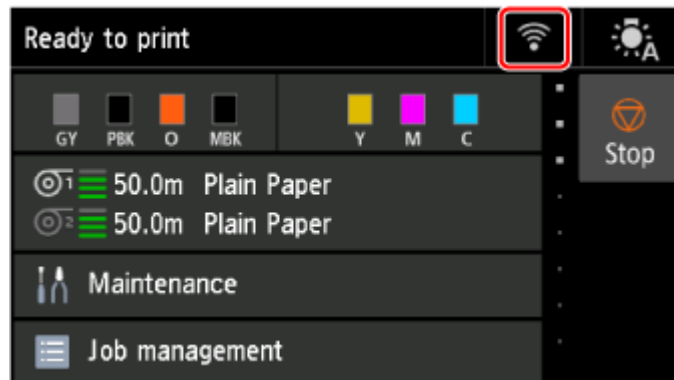

If icon is not displayed:

The printer is not set to enable wireless communication. Change the printer settings in order to use Wi-Fi. Turn on wireless communication on the printer.

If  icon is displayed:

 icon indicates that the wireless router and the printer are not connected. Reconsider the locations of the wireless router and the printer.

- Checking the location of wireless router:

After checking the wireless router setting, make sure the printer is not placed too far away from the wireless router. The printer can be up 164 ft. (50 m) from the wireless router indoors if unobstructed. Make sure the printer is close enough to the wireless router to be used.

Place the printer and wireless router where there are no obstacles between them. Wireless communication between different rooms or floors is generally poor. Wireless communication can be impeded by building materials containing metal or concrete. If the printer cannot communicate with the computer over a Wi-Fi due to a wall, place the printer and the computer in the same room.

In addition, if a device like a microwave oven that emits radio waves of the same frequency bandwidth as a wireless router is nearby, it may cause interference. Place the wireless router as far away from interference sources as possible.

- Checking the location of printer:

Make sure that the printer is not placed behind an object. The printer may not be connected when placed behind a wall or on a shelf. Try to place the printer in a location where there is no obstacle.

For details, see the instruction manual supplied with the wireless router or contact the manufacturer.

|| Step 2 | Solve the Problem, Using Wi-Fi Connection Assistant

Diagnose and repair the network connections using Wi-Fi Connection Assistant.

Download Wi-Fi Connection Assistant from the below page, and install it on your computer.

- ➡ Checking Printer Connection Status Using Wi-Fi Connection Assistant

If you can connect to the network, try to set up from the beginning.

Items to check for wired LAN

|| Step 1 | Check the basic items for wired LAN

1. Check the power and LAN Cable

When the printer cannot be found on the setup screen, using wired LAN connection setup, make sure that all the network devices are connected with the router and the hub via LAN cables and that all the devices are turned on.

If LAN cable is not connected:

Connect the router, hub, computer and printer via LAN cables.

Make sure the printer is turned on.

Make sure the printer is turned on, and make sure that the router and the hub are turned on.

If LAN cable is connected, and printer and network device are off:

Turn on printer or network device.

If LAN cable is connected, and printer and network device are on:

If they are on, turn them off and on again.

▶▶▶ Note

- It may take a while for the printer and network device to become ready for use once they are turned on again. After turning it on, wait for a while and proceed.

2. Check PC network connection

Can you view any web pages on your computer? Make sure the computer and network device (router, etc.) are configured and the computer is connected to the network.

If you cannot view web pages, unplug the cable connected to the router's WAN side. Connect the cable directly to the computer to see if you can view web pages on the Internet.

Check the settings for the router if you were able to view web pages. For details on checking the settings of the router, refer to the instruction manual supplied with the router or contact the manufacturer. Refer also to the instruction manual regarding the connection of the provider.

Once you complete checking the router, configure the network settings of your computer. For the procedures, refer to the instruction manual supplied with the computer, or contact the manufacturer.

Once you complete setting up the router and your computer, configure the settings on your computer to view web pages, using the information of the router.

Proceed once you can view web pages on your computer.

3. Check printer's wired LAN settings

Make sure the  icon is displayed on the touch screen.

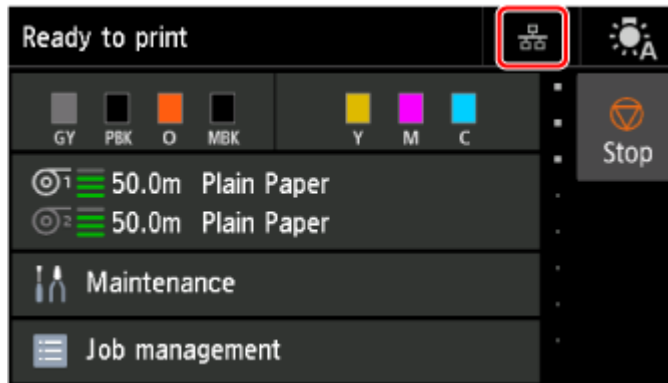

If icon is not displayed:

The printer is not set to enable wired communication. Change the printer settings in order to use wired LAN.

When you complete checking [Step 1] above, try to set up from the beginning.

If the printer cannot be detected after trying to set up from the beginning, proceed to [Step 2].

|| Step 2 || Solve the Problem, Using Wi-Fi Connection Assistant

Diagnose and repair the network connections using Wi-Fi Connection Assistant.

Download Wi-Fi Connection Assistant from the below page, and install it on your computer.

➡ [Checking Printer Connection Status Using Wi-Fi Connection Assistant](#)

If you can connect to the network, try to set up from the beginning.



Cannot Find Printer while Using Wi-Fi



Check 1 Make sure printer is turned on.

If not, make sure the printer is securely plugged in and press **ON** button to turn on.

The **ON** lamp flashes while the printer is initializing. Wait until the **ON** lamp stops flashing and remains lit.

Check 2 Check the network status on the touch screen.

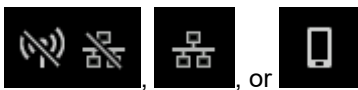

If , , or  only is displayed, the printer's wireless LAN (Wi-Fi) is disabled.

Set **Enable/disable Wi-Fi** in the touch screen menu to **Enable**.



If the  icon is displayed, see Check 3 or later checking items to make sure whether printer setup is complete or the settings of wireless router to connect are correct.

Check 3 Make sure printer setup is complete on the computer.

If it is not, perform setup.

- For Windows:
Perform setup using the Setup CD-ROM or from Setup Guide.
- For macOS:
Perform setup from Setup Guide.

▶▶▶ Note

- Wi-Fi Connection Assistant allows you to diagnose and repair the network status.

Select the link below to download Wi-Fi Connection Assistant and install it.

➔ [Checking Printer Connection Status Using Wi-Fi Connection Assistant](#)

Check 4 Make sure printer and wireless router network settings match.

Make sure the network settings of the printer (e.g. wireless router name, SSID, network key, etc.) are identical with those of the wireless router.

To check the settings of the wireless router, refer to the instruction manual provided with it or contact its manufacturer.

▶▶▶ Note

- Use 2.4 GHz frequency band to connect to a wireless router. Match the SSID set for the printer with that for 2.4 GHz frequency band of the wireless router.

You can check the network name (SSID) set for the printer by displaying it on the touch screen.

➔ [LAN settings](#)

▶▶▶ Note

- Wi-Fi Connection Assistant allows you to diagnose and repair the network status.
Select the link below to download Wi-Fi Connection Assistant and install it.
➔ [Checking Printer Connection Status Using Wi-Fi Connection Assistant](#)

Check 5 Make sure the printer is not placed too far away from the wireless router.

If the distance between the printer and wireless router is too far, wireless communication becomes poor. Place the printer and wireless router close to each other.

▶▶▶ Note

- Though an antenna is attached to most wireless routers, note that some of them have it inside.

Check 6 Make sure wireless signal is strong. Monitor signal strength and move printer and wireless router as necessary.

Place the printer and wireless router where there are no obstacles between them. Wireless communication between different rooms or floors is generally poor. Wireless communication can be impeded by building materials containing metal or concrete. If the printer cannot communicate with the computer over a Wi-Fi due to a wall, place the printer and the computer in the same room.

In addition, if a device like a microwave oven that emits radio waves of the same frequency bandwidth as a wireless router is nearby, it may cause interference. Place the wireless router as far away from interference sources as possible.

▶▶▶ Note

- Wi-Fi Connection Assistant allows you to diagnose and repair the network status.
Select the link below to download Wi-Fi Connection Assistant and install it.
➔ [Checking Printer Connection Status Using Wi-Fi Connection Assistant](#)

Check 7 Make sure the computer is connected to the wireless router.

For more on how to check the computer settings or connection status, see your computer instruction manual or contact its manufacturer.

▶▶▶ Note

- If you use a smartphone or tablet, make sure the Wi-Fi is enabled on the device.

Check 8 Make sure **Enable bidirectional support** is selected in the **Ports** sheet of the properties dialog box of the printer driver. (Windows)

If not, select it to enable bidirectional support.

Check 9 Make sure security software's firewall is off.

If your security software's firewall is on, a message may appear warning you that Canon software is attempting to access the network. If this warning message appears, set security software to always allow access.

If you are using any programs that switch between network environments, check their settings.

Check 10 If printer is connected to an AirPort Base Station via LAN, make sure you use alphanumeric characters for network identifier (SSID). (macOS)

If the problem is not resolved, redo setup.

- For Windows:
Perform setup using the Setup CD-ROM or from Setup Guide.
- For macOS:
Perform setup from Setup Guide.



Cannot Find Printer while Using Wired LAN



Check 1 Make sure printer is turned on.

If not, make sure the printer is securely plugged in and press **ON** button to turn on.

The **ON** lamp flashes while the printer is initializing. Wait until the **ON** lamp stops flashing and remains lit.

Check 2 Make sure LAN cable is connected properly.

Make sure the printer is connected to the router with the LAN cable. If the LAN cable is loose, connect the cable properly.

If the LAN cable is connected to the WAN side of the router, connect the cable to the LAN side of the router.

Check 3 Is  icon displayed on touch screen?

If the icon is not displayed, wired LAN is disabled.

Select **LAN settings** on the HOME screen, and select **Wired LAN > Settings > Enable/disable Wired LAN > Enable**.

Searching Printer by IP Address or Host Name During Setup

If the printer cannot be found on the **Select Printer** screen, search for the printer by an IP address or host name. Click **Search By IP Address** on the screen which appears by clicking **Printer Not Found**. The screen to select searching criteria appears.

1. Check printer's IP address or host name.

You can check the IP address or host name set for the printer by displaying it on the touch screen.

➔ [LAN settings](#)

▶▶▶ Note

- If you use the printer in an office, ask the network administrator.

2. Specify searching method.

Select one of the methods below.

Specify Printer Search Method

Search by IPv4 address **A**

Search by IPv6 address **B**

Search by host name **C**

In order to search for your printer by IP address, you must first assign an IP address to the printer. For more details, click [\[Instructions\]](#).

[Instructions](#)

Back **Next**

A: Search by IPv4 address

Select to search for printers by IPv4 address.

B: Search by IPv6 address

Select to search for printers by IPv6 address.

C: Search by host name

Select to search for printers by host name. A host name is referred to as LLMNR host name or Bonjour name.

3. Enter IP address or host name and click **Next**.

Printer search starts.

If an error screen appears:

Resolve the error according to the instruction on the screen.

If the IP address you entered is already used for another device, follow the procedure below to specify printer's IP address.

1. Select  **LAN settings** on HOME screen.

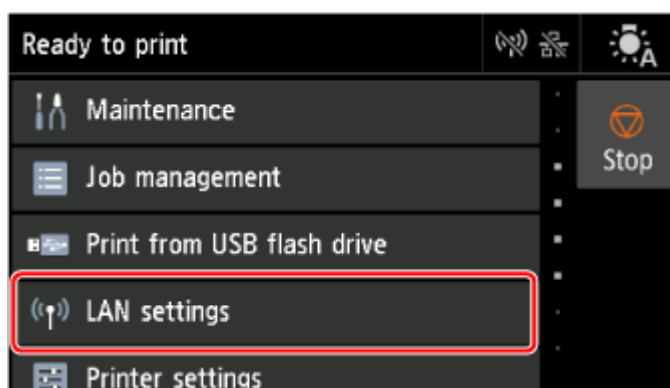

If you specify the administrator password, enter the password.

2. Select **Wi-Fi**.
3. Select **Settings**.
4. Select **Advanced**.
5. Select **TCP/IP settings**.

- If you specify IPv4 address:

1. Select **IPv4**.
2. Select **Yes** on the displayed screen.
3. Select **IP address**.
4. Select **Manual setup**.

Selecting **Auto setup** specifies the IP address automatically.

5. Enter IP address.
6. Select **OK**.

7. Enter subnet mask.
8. Select **OK**.
9. Enter default gateway.
10. Select **OK**.

The IPv4 address has been specified.

- **If you specify IPv6 address:**

1. Select **IPv6**.
2. Select **Yes** on the displayed screen.
3. Select **Enable/disable IPv6**.
4. Select **Enable**.

The IPv6 address has been specified.

»» Important

- If firewall is enabled on the computer, printers on a different subnet may not be detected. Disable firewall.

If firewall interferes with printer search:

- **If a firewall message appears:**

If a firewall message appears warning that Canon software is attempting to access the network, set the security software to allow access.

After allowing the software to access, specify the IP address or host name and search for printers again.

If the printer is found, follow the instructions on the screen to continue to set up the network communication.

- **If no firewall message appears:**

Temporarily disable the firewall and specify the IP address or host name to search for printers again.

After the setup is complete, re-enable the firewall.

»» Note

- For more on firewall settings of your operating system or security software, see instruction manual or contact its manufacturer.

Cannot Print over Network

- **Cannot Print over TCP/IP Network**
- **Cannot Print over Bonjour networks**
- **Cannot Print Using AirPrint**



Cannot Print over TCP/IP Network



Check 1 Is the printer's IP address configured correctly?

Make sure the printer's IP address is configured correctly.

▶▶▶ Note

- For Windows, you can configure the printer's IP address using Wi-Fi Connection Assistant.
For details, refer to "Performing/Changing Network Settings" > "Performing Network Settings" in Wi-Fi Connection Assistant Guide.
➔ [Wi-Fi Connection Assistant Guide](#)

Check 2 Are the printer's TCP/IP network settings configured correctly?

Make sure the printer's TCP/IP network settings are configured correctly.

Check 3 Is the computer you are trying to print from configured correctly?

Make sure the computer's TCP/IP network settings are configured correctly.



Cannot Print over Bonjour networks



Check 1 Is the computer you are trying to print from configured correctly?

Make sure the computer is configured correctly.

Check 2 Are the computer and printer on the same network?

Due to the nature of Bonjour, printing may not be possible if the printer is on another network behind a router. Make sure the computer and printer are on the same network. For information about network settings, ask your network administrator.

Check 3 Are the printer's Bonjour settings configured correctly?

Make sure the Bonjour settings are configured correctly.



Cannot Print Using AirPrint



Check 1 Make sure printer is turned on.

If the printer is turned on, turn it off and back on, and then check whether the issue is resolved.

Check 2 Make sure printer is registered to your computer.

Check 3 Make sure printer is connected by LAN to same network subnet as AirPrint compliant device when printing over LAN.

Check 4 Make sure printer has enough paper and ink.

Check 5 Make sure no error message is displayed on printer's touch screen.

Network Connection Problems

- **Network Settings and Common Problems**
- **Cannot Connect to the Printer**

Network Settings and Common Problems

Here are frequently asked questions on network.

Cannot Find Printer

- ➔ [Cannot Find Printer During Setup](#)
- ➔ [Cannot Proceed beyond Printer Connection Screen/Connect Cable Screen](#)
- ➔ [Searching Printer by IP Address or Host Name During Setup](#)
- ➔ [Cannot Find Printer while Using Wi-Fi](#)
- ➔ [Cannot Find Printer while Using Wired LAN](#)
- ➔ [Cannot Print Using AirPrint](#)

Cannot Print or Connect

- ➔ [Cannot Connect Printer to Network](#)
- ➔ [Cannot Print over TCP/IP Network](#)
- ➔ [Cannot Print over Bonjour networks](#)
- ➔ [Cannot Connect to the Printer](#)

LAN Setting Tips/Changing LAN Settings

- ➔ [Printer Connection Methods](#)
- ➔ [LAN settings](#)
- ➔ [Another Printer Found with Same Name](#)
- ➔ [Printing Network Settings](#)
- ➔ [Network Status and Troubleshooting](#)

Cannot Connect to the Printer

- ➔ [Cannot Connect to a Printer after Network Configuration Changes](#)
- ➔ [Cannot Connect to a Printer via Wi-Fi](#)
- ➔ [Cannot Connect to a Printer through Wireless Direct](#)
- ➔ [Cannot Connect to a Printer via Wired LAN](#)
- ➔ [Cannot Print through Network](#)

Cannot Connect to a Printer after Network Configuration Changes

It may take a while for the computer to obtain an IP address, or you may need to restart your computer. Make sure the computer has obtained a valid IP address, and try again to find the printer.

Cannot Connect to a Printer via Wi-Fi

Check 1 Check the power status of printer and devices (e.g. wireless router or computer) connected to the network.

Turn on the printer or devices.

If the power is already turned on, turn it off and on again.

It may be necessary to resolve wireless router problems (e.g. update interval of a key, problems of DHCP update interval, energy saving mode, etc.) or to update the wireless router firmware.

For details, contact the manufacturer of your wireless router.

Check 2 Can you view any web pages on your computer?

Make sure your computer is connected to the wireless router properly.

For more on checking computer settings or connection status, see the instruction manual supplied with the computer or contact the manufacturer.

Check 3 Is the printer connected to the wireless router?

Use the icon on the touch screen to check the connection status between the printer and wireless router. If the



icon is not displayed, Wi-Fi is disabled. Turn on wireless communication on the printer.

Check 4 Make sure the printer and wireless router network settings match.

Make sure the network settings of the printer (e.g. wireless router name, SSID, network key, etc.) are identical with those of the wireless router.

To check the settings of the wireless router, refer to the instruction manual provided with it or contact its manufacturer.

You can check the current network settings for the printer by displaying them on the touch screen.

➡ [LAN settings](#)

➤➤➤ Note

- Wi-Fi Connection Assistant allows you to diagnose and repair the network status.

Select the link below to download Wi-Fi Connection Assistant and install it.

➡ [Checking Printer Connection Status Using Wi-Fi Connection Assistant](#)

Check 5 Make sure the printer is not placed too far away from the wireless router.

If the distance between the printer and wireless router is too far, wireless communication becomes poor. Place the printer and wireless router close to each other.

➤➤➤ Note

- Though an antenna is attached to most wireless routers, note that some of them have it inside.

Check 6 Make sure wireless signal is strong. Monitor signal status and move printer and wireless router as necessary.

Place the printer and wireless router where there are no obstacles between them. Wireless communication between different rooms or floors is generally poor. Wireless communication can be impeded by building materials containing metal or concrete. If the printer cannot communicate with the computer over a Wi-Fi due to a wall, place the printer and the computer in the same room.

In addition, if a device like a microwave oven that emits radio waves of the same frequency bandwidth as a wireless router is nearby, it may cause interference. Place the wireless router as far away from interference sources as possible.

➤➤➤ Note

- Wi-Fi Connection Assistant allows you to diagnose and repair the network status.

Select the link below to download Wi-Fi Connection Assistant and install it.

➡ [Checking Printer Connection Status Using Wi-Fi Connection Assistant](#)

Check 7 Make sure of the Wi-Fi channel numbers used for your computer.

You need to have the same Wi-Fi channel number that you are using for the wireless router as your computer. It is normally set in the way that you can use all the Wi-Fi channels. However, when the channels that you are using are restricted, the Wi-Fi channels do not match.

See the instruction manual provided with your computer and check the Wi-Fi channel number available for your computer.

Check 8 Make sure channel set on wireless router is a usable channel as confirmed in Check 7.

If it is not, change the channel set on the wireless router.

Check 9 Make sure security software's firewall is off.

If your security software's firewall is on, a message may appear warning you that Canon software is attempting to access the network. If this warning message appears, set security software to always allow access.

If you are using any programs that switch between network environments, check their settings.

Check 10 If printer is connected to an AirPort Base Station via LAN, make sure you use alphanumeric characters for network identifier (SSID). (macOS)

If the problem is not resolved, redo setup.

- For Windows:
Perform setup using the Setup CD-ROM or from Setup Guide.
- For macOS:
Perform setup from Setup Guide.

Cannot Connect to a Printer through Wireless Direct

Check 1 Check the power status of printer and other devices (smartphone or tablet).

Turn on the printer or devices.

If the power is already turned on, turn it off and on again.

Check 2 Is the  icon displayed on the touch screen?

If not, Wireless Direct is disabled. Turn on Wireless Direct.

Check 3 Check the settings of your device (smartphone/tablet).

Make sure Wi-Fi is enabled on your device.

For details, refer to your device's instruction manual.

Check 4 Make sure printer is selected as connection for device (e.g. smartphone or tablet).

Select the identifier for Wireless Direct (SSID) specified for the printer as the connection destination for devices.

Check the destination on your device.

For details, refer to your device's instruction manual or visit the manufacturer's website.

When using wireless direct, you can check the network name (SSID) set for the printer by displaying it on the touch screen.

➔ [LAN settings](#)

Check 5 Have you entered the proper password specified for the Wireless Direct?

You can check the password set for the printer by displaying it on the touch screen.

➔ [LAN settings](#)

Check 6 Make sure the printer is not placed too far away from the device.

If the distance between the printer and device is too far, wireless communication becomes poor. Place the printer and device close to each other.

Check 7 Make sure 5 devices are already connected.

Wireless Direct does not allow more than 5 devices to be connected.

Cannot Connect to a Printer via Wired LAN

A

Check 1 Make sure the printer is turned on.

Check 2 Make sure the LAN cable is connected properly.

Make sure the printer is connected to the router with the LAN cable. If the LAN cable is loose, connect the cable properly.

If the LAN cable is connected to the WAN side of the router, connect the cable to the LAN side of the router.

If the problem is not resolved, redo setup.

- For Windows:
Perform setup using the Setup CD-ROM or from Setup Guide.
- For macOS:
Perform setup from Setup Guide.

Cannot Print through Network

A

Check 1 Make sure the computer is connected to the wireless router.

For more on how to check the computer settings or connection status, see your computer instruction manual or contact its manufacturer.

Check 2 If the printer driver is not installed, install it. (Windows)

Install the printer driver using the Setup CD-ROM or install it from Setup Guide.

Check 3 When using Wi-Fi, make sure wireless router does not restrict which computers can access it.

For more on connecting to and setting up your wireless router, see the wireless router instruction manual or contact its manufacturer.

Printer Problems

- **Printer Does Not Turn On**
- **Messages advising to check the maintenance cartridge are not cleared**
- **The Data lamp on the Operation Panel does not light up**
- **If the Printer Makes a Strange Sound**
- **Printed pages are not collected cleanly in the basket**
- **Basket Lurches**
- **Warning Message is Displayed When Performing Color Calibration**



Printer Does Not Turn On



Check 1 Is the power cord plugged in?

Plug the power cord into the outlet, and then turn on the printer.

Check 2 Is the specified voltage being supplied?

Check the voltage of the outlet and breaker.

➔ [Specifications](#)



Messages advising to check the maintenance cartridge are not cleared



The newly replaced maintenance cartridge is not recognized.

Remove the newly replaced maintenance cartridge, and then reinsert it again firmly.

➔ [Replacing the Maintenance Cartridge](#)



The Data lamp on the Operation Panel does not light up



Check 1 Was the correct printer selected?

In Windows, select the printer by clicking **Select Printer** or **Printer** in the printing dialog box and try printing again.

In macOS, open the dialog box of the printer driver, select the printer from the list of **Printer**, and try printing again.

Check 2 Is the print job paused?

In Windows, restart the print job as follows.

1. Select the target printer in **Devices and Printers** or **Printers & scanners**.
2. Uncheck **Pause** or select **Resume**.

In macOS, restart the print job as follows.

1. Click **Print & Scan** (or **Print & Fax**).
2. Select the printer, and then **Resume Printer** (or **Start Jobs**) in the **Printers** menu to restart the print job.



If the Printer Makes a Strange Sound



Check 1 Has an unusual noise been produced from the vicinity of the roll holder?

If dust accumulates on the gear (A) at the end of the roll holder, a noise may be produced from that area.

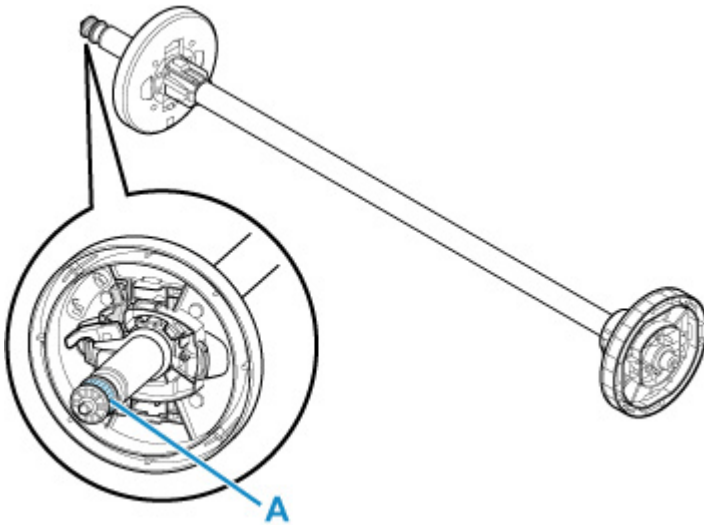

When the noise starts, clean the gear with the following procedure.

1. Remove the roll holder from the printer.
2. Wipe the dust off the gear with a damp, tightly wrung cloth, and then dry with a dry cloth.
3. Insert the roll holder in the printer.

Check 2 Operating noise may be heard from the printer even when not printing.

The following sounds do not indicate a problem with the printer.

- A suction sound can be heard from the platen
To prevent the paper from rising, the surface of the platen has vacuum holes that create suction on the paper.
- Roll paper makes a fluttering sound during printing.
There may be a fluttering sound when large paper is advanced.
- You suddenly hear the sound of cleaning operations.
Cleaning is automatically performed at specified intervals in order to keep the printer maintained.
- You suddenly hear the sound of ink agitation.

Ink is automatically agitated after specified intervals to maintain optimal print quality. Agitation takes approximately 1 minute 30 seconds.

Ink is also agitated automatically at the following times. Please note that no other operations can be performed while "Agitating the ink" is on the touch screen.

- After the printer is turned on
- After data transmission
- After ink tank replacement

In other cases, contact your Canon dealer.



Printed pages are not collected cleanly in the basket



Check 1 Is the roll unit in place?

The basket may not be able to catch printed paper properly if the roll unit is in place.

Refer to Example Basket Configurations and try another basket position.

➔ [Example Basket Configurations](#)

Check 2 Is the basket in the right position for the media size?

The optimal basket position depends on factors such as media size and the conditions the printer is being used under.

Refer to Example Basket Configurations and try another basket position.

➔ [Example Basket Configurations](#)



Basket Lurches



Make sure a Basket Locking Support is attached to the Basket Arm. The basket may lurch if a force is applied to the one without the Basket Locking Support. To prevent the basket from lurching, attach the Basket Locking Supports to both sides of the Basket Arm.

➔ [Using the Basket on the Printer Stand](#)



Warning Message is Displayed When Performing Color Calibration



In the following cases, perform color calibration again or create a color calibration target.

- A warning message is displayed when performing color calibration.
- A warning message is displayed when creating a color calibration target.
- An error was seen in the print result when printing on a calibrated sheet.

An example of a warning message

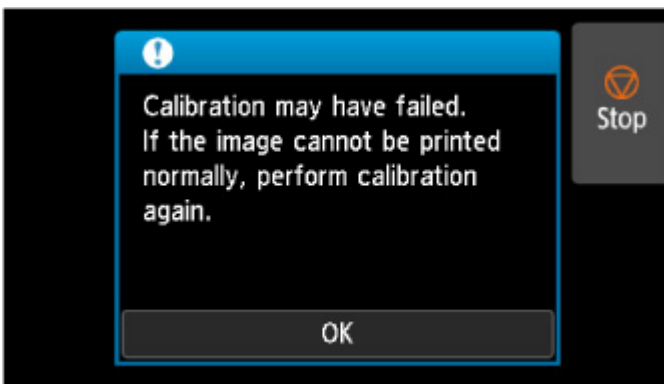

Please check the following:

- The print head nozzles are not blocked.
- The paper is not curled or bent.
- The paper is loaded correctly.
- Paper settings are specified correctly.
- The paper size is compatible with color calibration.

➔ [Performing Color Calibration](#)

Paper is not Fed or Ejected Properly

- **Remove Jammed Roll Paper**
- **Remove a Jammed Sheet**
- **Roll paper cannot be inserted into the Paper Feed Slot**
- **Cannot load sheets**
- **Roll Paper Is not Fed Automatically**
- **Roll Paper Is not Switched Automatically**
- **Paper Source Does Not Switch When Roll Paper Is Used Up**
- **Roll Paper Remains/Lacks under Quantity Management**
- **The printer ejects blank, unprinted paper**



Remove Jammed Roll Paper



If roll paper jams, follow the steps below to remove jams.

▶▶▶ Note

- If "The paper is jammed. Lift the release lever and remove the paper." appears on the touch screen, Step 1 and Step 9 can be skipped.

1. Turn off the power to the printer.

➔ [Turning the Printer On and Off](#)

2. Open the top cover.

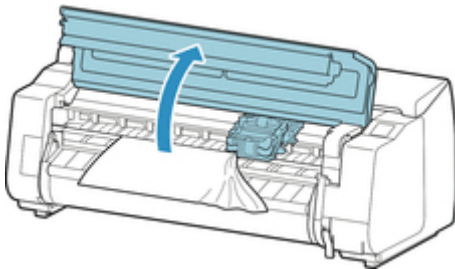

▶▶▶ Note

- If the roll paper is very curled or the leading edge of the roll paper blocks the Carriage, setting the cutting method for the roll paper to **User cut** and leading edge detection to **Do not detect** may stop the paper from blocking the carriage.

➔ [Specifying the Cutting Method for Rolls](#)

3. If the Carriage is out, move the Carriage to the left or right side, away from the jammed paper.

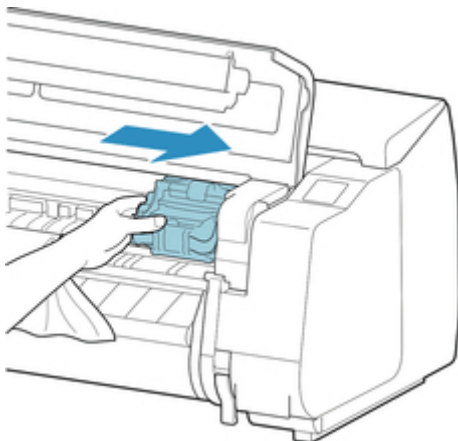

»» Important

- Do not touch the linear scale (A), carriage shaft (B), or ink tube stabilizer (C). Touching these may cause malfunction.

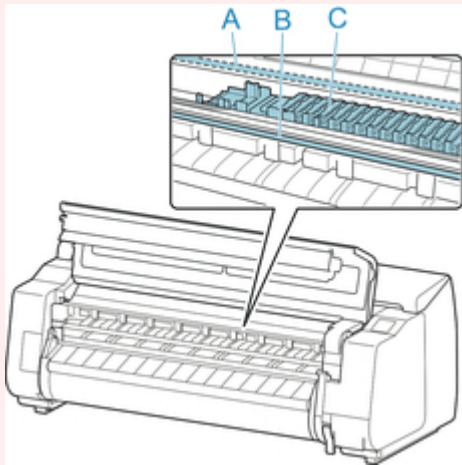

4. Lift up the release lever.

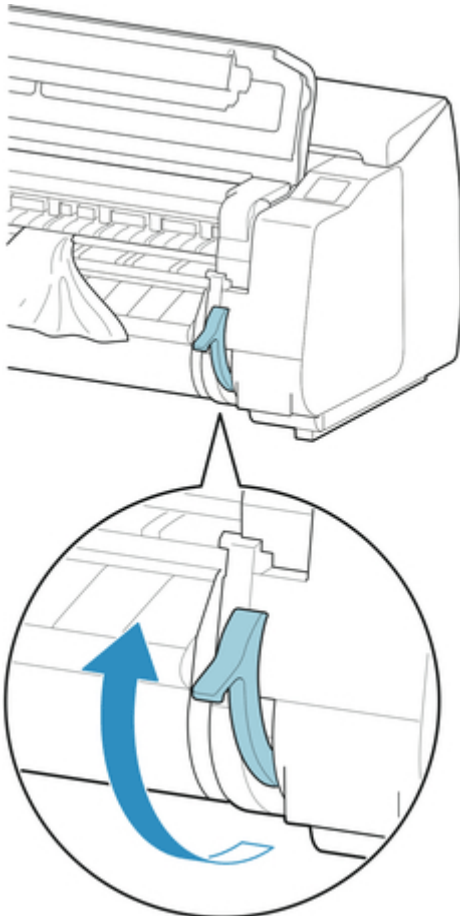

5. Holding the paper on both sides, pull the jammed portion out toward the front. Use scissors or a cutting tool to cut away the printed or wrinkled portion.

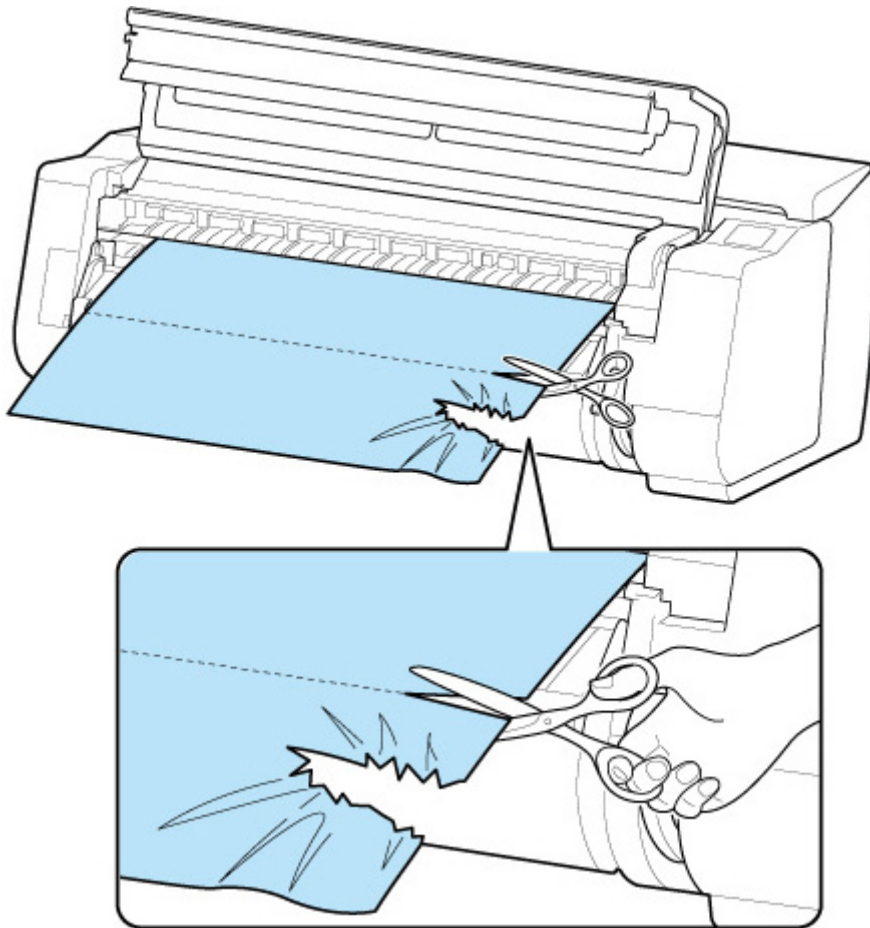

⚠ Caution

- Be careful not to injure yourself or scratch the printer when cutting.

6. If the Carriage is on the left, move the Carriage to the right until it stops.

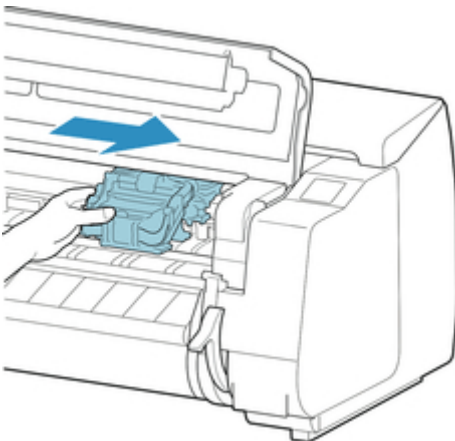

▶▶ Important

- Always move the Carriage to the right side. If the Carriage is on the left, an error message may appear on the touch screen when you turn on the printer.

7. Hold the leading edge of the roll paper in the middle and pull it gently and evenly until it reaches the output guide (A) position. At this time, align the right edge of the roll paper parallel to the paper alignment line (B). When the paper is parallel to the line, lower the release lever.

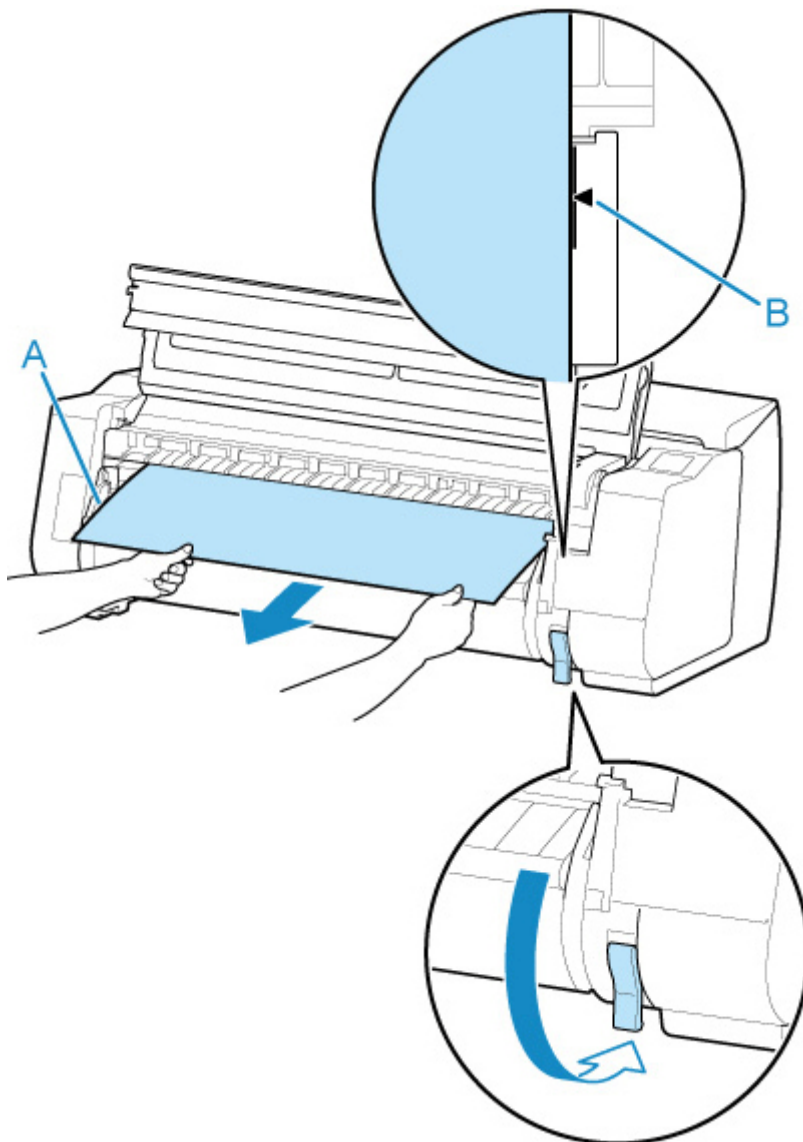

»» Important

- Align the roll paper with the paper alignment line (B) and make sure to keep the paper tension.
- Do not pull the roll paper forcefully. This might cause the roll paper to feed at an angle.

8. Close the top cover.

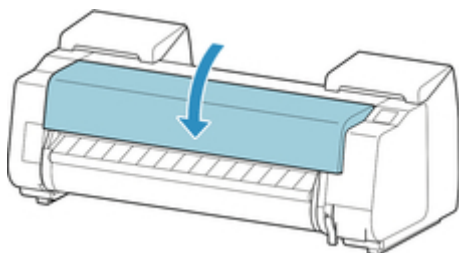

9. Turn on the power to the printer.

➔ [Turning the Printer On and Off](#)

The roll is advanced and the printer is ready to print.

»» Note

- To trim the leading edge cleanly, select the paper being fed on the touch screen, and then cut the leading edge by selecting **Cut paper** in **Feed/cut**.

➔ [Cutting Roll Papers](#)



Remove a Jammed Sheet



If a sheet jams, follow the steps below to remove it.

1. Turn off the power to the printer.

➔ [Turning the Printer On and Off](#)

2. Open the top cover.

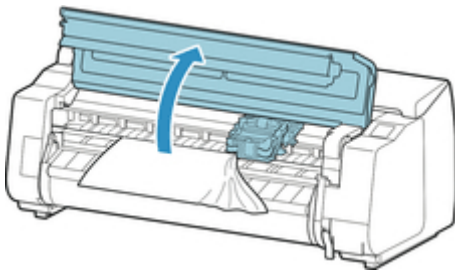

3. If the Carriage is out, move the Carriage to the left or right side, away from the jammed paper.

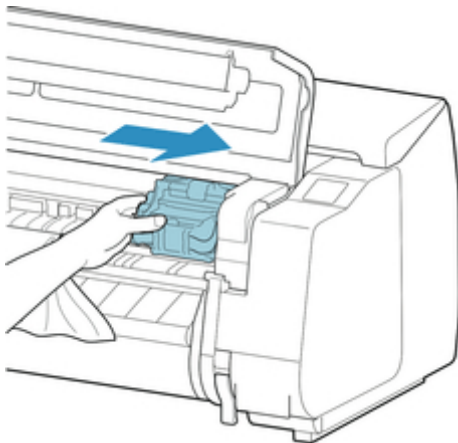

►► Important

- Do not touch the linear scale (A), carriage shaft (B), or ink tube stabilizer (C). Touching these may cause malfunction.

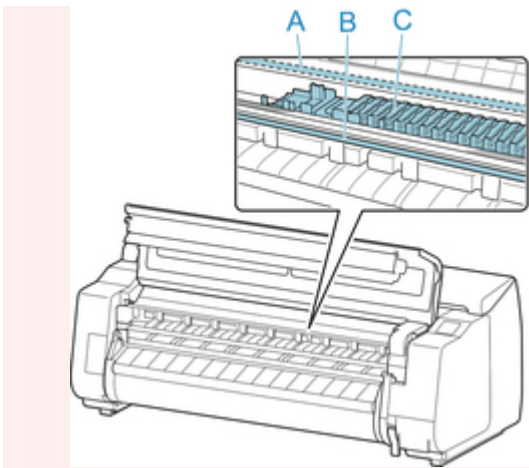

4. Lift up the release lever.

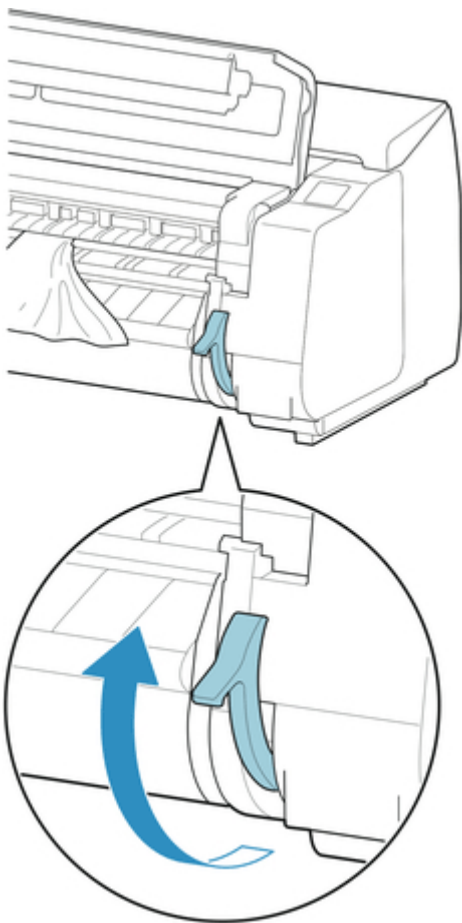

5. Hold the paper and pull it out toward the front.

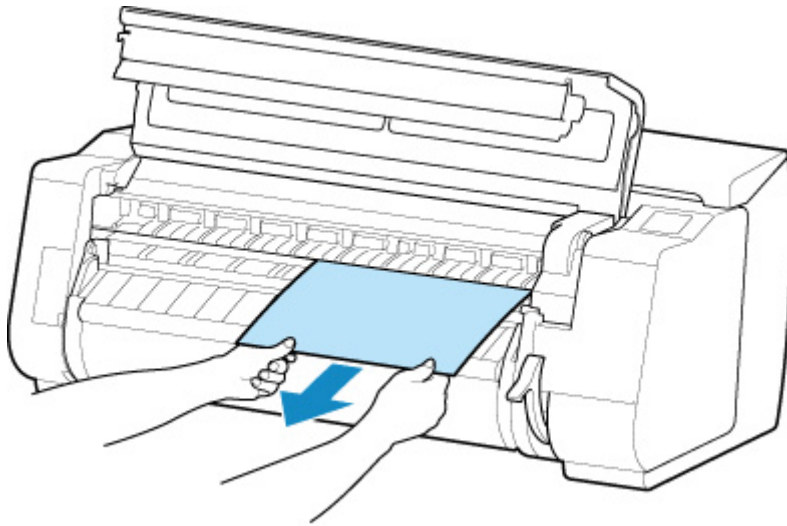

After removing the paper, inspect the interior to ensure paper fragments or other objects do not remain.

6. If the Carriage is on the left, move the Carriage to the right until it stops.

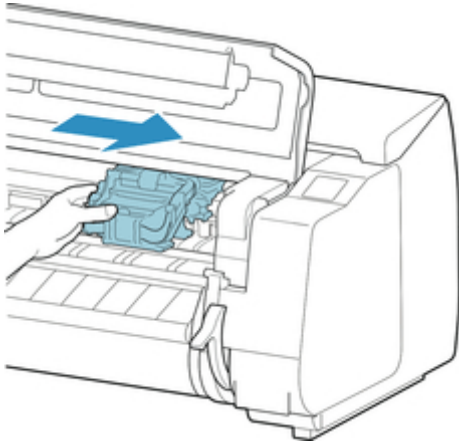

»» Important

- Always move the Carriage to the right side. If the Carriage is on the left, an error message may appear on the touch screen when you turn on the printer.

7. Lower the release lever and close the top cover.

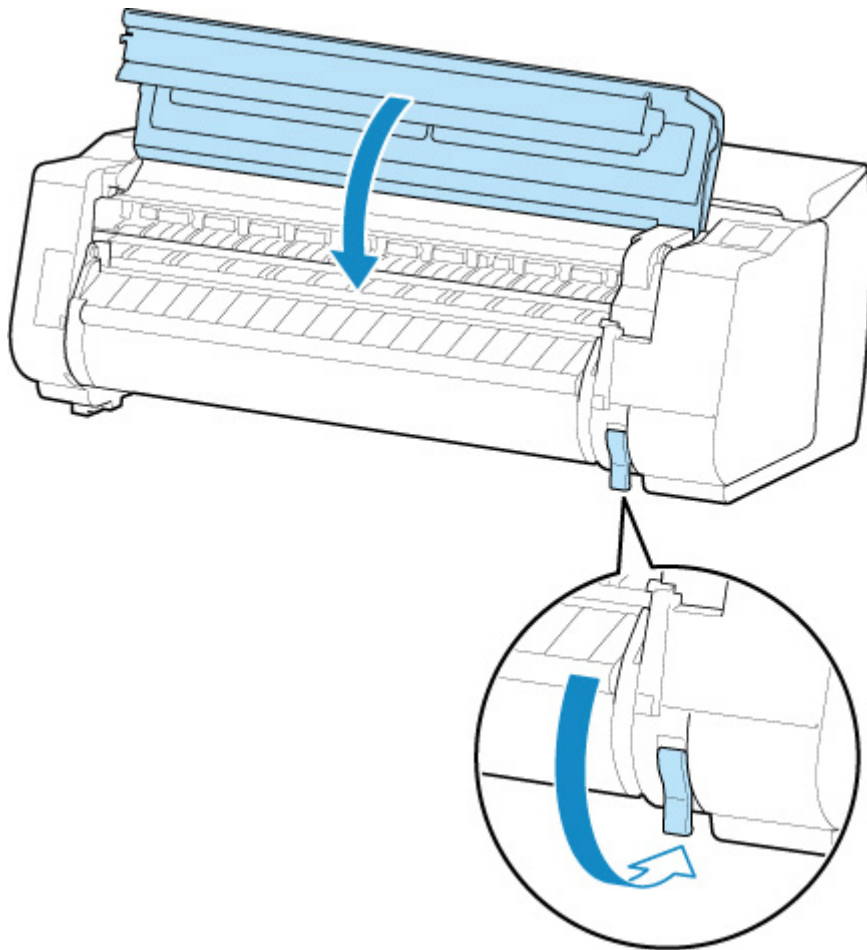

8. Turn on the power to the printer.
 - ➔ [Turning the Printer On and Off](#)



Roll paper cannot be inserted into the Paper Feed Slot



Check 1 Is the roll paper curled?

Straighten out curls and reload the roll.

Check 2 Is paper jammed in the feed slot?

Remove the jammed paper.

- ➔ [Remove Jammed Roll Paper](#)
- ➔ [Remove a Jammed Sheet](#)

Check 3 Check that the correct paper source has been selected.

Tap Paper Setting Display in the touch screen menu, and then select the paper source.

Check 4 The leading edge of the roll paper may not be cut properly.

If the leading edge of the roll paper is crooked or folded, the paper may not be fed correctly. Cut the leading edge with scissors to straighten it. If the roll paper has a printed barcode, be careful not to cut the barcode part.

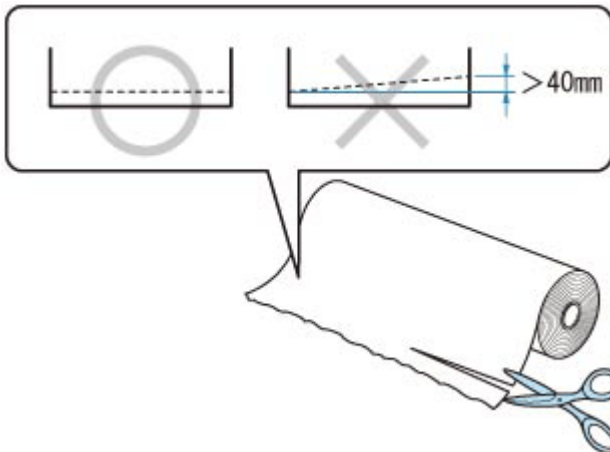

Check 5 Is the roll unit in **Take-up mode** when feeding from the roll unit?

Select **Roll unit use settings** in the touch screen menu, and set it to paper feed mode.

- ➔ [Switching Roll Unit Modes](#)



Cannot load sheets



Check Check that the correct paper source has been selected

Tap Paper Settings Display area in the touch screen menu, and then select the paper source.

Select **Load paper** and load the paper.

➔ [Loading Sheets in the Printer](#)



Roll Paper Is not Fed Automatically



Check 1 Check the auto feed settings.

Select **Enable** for **Roll paper auto feed** on **Paper-related settings**.

➔ [Paper-related settings](#)

Check 2 Check the setting for **Paper retention settings**.

Select **While feeding** for **Paper retention settings** on **Paper-related settings**.

➔ [Paper-related settings](#)

Check 3 Make sure automatic paper feed can be used for the roll you are using.

Refer to "Paper Setting List(Roll Paper)" to make sure automatic paper feed can be used for the roll you are using.

➔ Paper Information List

Check 4 Make sure the roll is being fed.

If not, feed the roll manually.

➔ [Loading Rolls in the Printer](#)

➔ [Loading Roll Paper in the Roll Unit](#)

Check 5 Make sure the paper width of the roll is 250 mm or more.

The auto feed function does not support paper with a width of less than 250 mm.

If you use the roll with paper width less than 250 mm, select **Disable** for **Roll paper auto feed** on **Paper-related settings** and feed paper manually.

➔ [Loading Rolls in the Printer](#)

➔ [Loading Roll Paper in the Roll Unit](#)

Check 6 Are you using an old roll holder?

Be sure to use the roll holder supplied with the printer.

➔ [Roll Holder Set](#)

Check 7 The leading edge of the roll paper may not be cut properly.

If the leading edge of the roll paper is crooked or folded, the paper may not be fed correctly. Cut the leading edge with scissors to straighten it. If the roll paper has a printed barcode, be careful not to cut the barcode part.

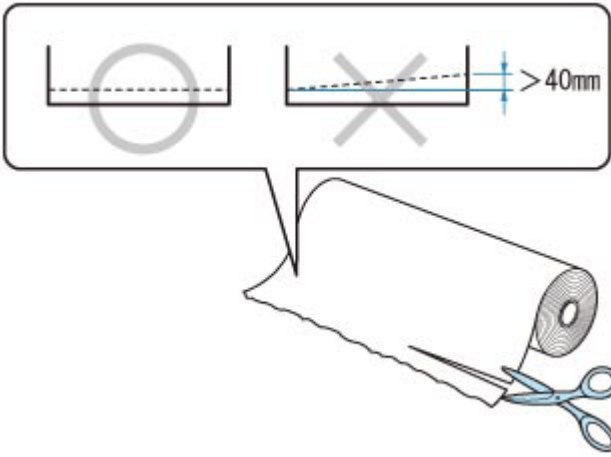

Depending on the operating conditions of the printer (temperature, humidity, etc.), auto feed may not work. If paper cannot be fed even after performing the above actions, set **Roll paper auto feed** to **Disable**, **Paper retention settings** to **Release**, and then feed the paper manually.

➡ [Paper-related settings](#)



Roll Paper Is not Switched Automatically



When using certain paper types and widths under certain temperature and humidity conditions, roll paper auto switching may not be possible.

Set **Paper retention settings** to **Release** in the touch screen menu and feed the paper manually.

- ➔ [Paper-related settings](#)
- ➔ [Loading Rolls in the Printer](#)
- ➔ [Loading Roll Paper in the Roll Unit](#)

▶▶▶ Note

- Roll paper cannot be fed or switched automatically until you change this setting.

If the roll cannot be switched at the end, make sure **Switch roll paper when low** is set to **Enable**.

- ➔ [Paper Source Does Not Switch When Roll Paper Is Used Up](#)



Paper Source Does Not Switch When Roll Paper Is Used Up



Check Check the paper settings.

Check the following setting items on **Paper-related settings** and perform settings.

- Select **Enable** for **Switch roll paper when low**.
- Select **Barcodes** or **Auto estimate** for **Manage remaining roll amount**.
- Select **While feeding** for **Paper retention settings**.

➔ [Paper-related settings](#)



Roll Paper Remains/Lacks under Quantity Management



Check 1 Is the remaining amount of loaded roll paper set correctly?

If all of the following conditions are met, you can specify the remaining amount of the loaded roll paper manually when you load it.

- **Barcodes** is selected for **Manage remaining roll amount**.
- **Enable** is selected for **Roll paper auto feed**.
- **Auto detect** or **Use current media type** is selected for **Media type selection method**.

➔ [Paper-related settings](#)

You must specify the remaining amount of roll within about five seconds. If you do not, the roll length specified on **Advanced paper settings** is regarded as the default value.

The difference between the value and actual length of loaded roll paper makes the remaining amount large or small.

Check 2 Check the setting of **Manage remaining roll amount**.

- If **Barcodes** is selected for **Manage remaining roll amount**:
 1. Enter **Length of roll paper 1** and **Length of roll paper 2**, and tap **OK**.
 2. Select the timing of warning messages from **Roll amount warning settings**.
- If **Auto estimate** is selected for **Manage remaining roll amount**:

Make sure the media type is configured correctly.

Make sure **Paper core outer diameter** and **Paper thickness** are configured correctly for **Advanced paper settings**.

➤➤➤ Note

- Paper core outer diameter and Paper thickness must be set correctly for auto estimation to be accurate.
- Contact the media manufacturer for paper core outer diameter and paper thickness.
- For pre-registered paper, the paper core outer diameter and paper thickness are set, but they may be changed at the convenience of the media manufacturer.
- If you want to use paper that is not displayed in the paper information list, set the paper thickness and paper core outer diameter in the Media Configuration Tool.
 - ➔ [Media Configuration Tool Guide](#)

➔ [Paper-related settings](#)



The printer ejects blank, unprinted paper



Check 1 The leading edge of the roll paper may have been trimmed.

The leading edge of the roll paper may be trimmed if **Trim edge first** is not set to **Off** or **Manual** in the touch screen menu.

➔ [Cutting the Leading Edge of Roll Paper Automatically](#)

Check 2 Is the Print head nozzle blocked?

Print a nozzle check pattern to check the Print head status.

➔ [Checking for Nozzle Clogging](#)

Check 3 Is the correct printer driver selected?

Print again using the correct printer driver for your printer.

If none of the above apply, there may be a printer malfunction.

Contact your Canon dealer for assistance.

Paper Cutting Problems

- **Paper is not cut**
- **Paper is not cut straight**
- **Cutter Blade Does Not Work While Cutting Is in Progress**
- **I want to know how to configure roll cutting**
- **I want to configure so that the roll is cut automatically after waiting for the ink to dry**
- **When Trim edge first is set, the trimmed paper is drawn into the roll unit**



Paper is not cut



Check 1 Is **Automatic Cutting** in the printer driver set to **No** or **Print Cut Guideline**?

Set the printer driver **Automatic Cutting** setting to **Yes**.

- ➔ Page Setup Tab Description (Windows)
- ➔ [Advanced Paper Settings](#) (macOS)

Check 2 Is **Cutting mode** in the touch screen menu set to **Eject cut** or **User cut**?

If **Cutting mode** is set to **Eject cut**, select **Cut paper** on the touch screen to cut the paper.

If **Cutting mode** is set to **User cut**, cut the roll paper with a cutting implement such as scissors.

- ➔ [Specifying the Cutting Method for Rolls](#)
- ➔ [Cutting Roll Paper after Printing](#)

Check 3 Is the cutter blade attached?

Attach the cutter blade.

- ➔ [Replacing the Cutter Blade](#)

Check 4 Is the cutting method for paper ejected after printing set to **Do not cut** when the roll unit is set to **Take-up mode**?

Follow the steps below to change the settings.

1. Select the roll unit on the touch screen.
2. Select **Roll unit use settings**, and then select **Use the cutting mode setting**.
3. Set the **Cutting mode** for **Roll paper 1** on the touch screen to **Automatic cut**.



Paper is not cut straight



Check 1 Is the edge of the paper cutting position creased?

Straighten out any curling by the edges of the paper.

Check 2 Is the edge of the paper cutting position lifting up when cutting?

Reload the paper correctly.

Check 3 Is the paper a type that can be cut with the cutter blade?

Set **Cutting mode** in the touch screen menu to **User cut**, then and cut the roll paper with a cutting implement such as scissors.

➔ [Specifying the Cutting Method for Rolls](#)

➔ [Cutting Roll Paper after Printing](#)

Check 4 Are you using the basket properly?

Make sure that you are using the basket properly.

➔ [Using the Basket on the Printer Stand](#)

Check 5 Check that the **Cut speed** setting is correct.

If the paper edge cannot be cut straight at the cut starting position, it may be improved by selecting slower cut speed than that selected currently.

If the paper edge cannot be cut straight at the cut ending position, it may be improved by selecting faster cut speed than that selected currently.

Select paper settings display area on Home screen of touch screen, select the feed slot where the paper to change is set, then select **Paper settings** > **Advanced** and change the setting value of **Cut speed**.

➔ [Advanced \(Paper settings\)](#)

Check 6 Did the printing material slip diagonally while being cut?

Set the **Cutting mode** in the touch screen menu to **Eject cut**, and then hold and cut the material after it has printed.

➔ [Specifying the Cutting Method for Rolls](#)

➔ [Cutting Roll Paper after Printing](#)

Check 7 Is the cutter blade attached properly?

Attach the cutter blade properly.

➔ [Replacing the Cutter Blade](#)

Check 8 Is the edge of the cutter blade blunt?

Replace the cutter blade.

➔ [Replacing the Cutter Blade](#)

Check 9 Are you printing on Large-Format?

Change the position of the basket.

➔ [Printing on Large-Format or Easily Damaged Paper \(Position 3\)](#)



Cutter Blade Does Not Work While Cutting Is in Progress



Check 1 Does a message appear on the touch screen?

If the cutter blade failed to cut the paper, it stops moving and a message appears on the touch screen.

Remove the paper and try printing again.

➔ [Remove Jammed Roll Paper](#)

Check 2 Make sure the cutter blade can cut paper used currently.

Select **User cut** for **Cutting mode** in the touch screen menu and cut the roll paper with a cutting implement such as scissors.

➔ [Specifying the Cutting Method for Rolls](#)

➔ [Cutting Roll Paper after Printing](#)

Check 3 Check the setting value for **Cut speed**.

Selecting slower value may enable the cutter blade to cut paper.

Select paper settings display area on Home screen of touch screen, select the feed slot where the paper to change is set, then select **Paper settings** > **Advanced** and change the setting value of **Cut speed**.

➔ [Advanced \(Paper settings\)](#)

Check 4 Is the edge of the cutter blade blunt?

Replace the cutter blade.

➔ [Replacing the Cutter Blade](#)



I want to know how to configure roll cutting



Cutting methods can be selected in the printer settings and printer driver settings.

To automatically cut roll paper after printing, open the **Cutting mode** settings on the printer, and then under **Automatic cut** set **Automatic Cutting** in the printer driver to **Yes**.

When using paper that is easily scratched, or paper where the ink requires extra time to fix, we recommend setting **Cutting mode** on the printer to **Eject cut**.

- ➔ [Specifying the Cutting Method for Rolls](#)
- ➔ [Cutting Roll Paper after Printing \(Windows\)](#)
- ➔ [Cutting Roll Paper after Printing \(macOS\)](#)

If using the Media Take-up Unit, see the pages below for cutting settings and rolling settings after cutting.

- ➔ [Switching Roll Unit Modes](#)
- ➔ [Removing Printed Paper from the Roll Unit](#)



I want to configure so that the roll is cut automatically after waiting for the ink to dry



You can set an ink drying time in the printer driver.

You can also configure the same settings on the printer itself.

➔ [Specifying the Ink Drying Time](#)



When Trim edge first is set, the trimmed paper is drawn into the roll unit



Check Is the basket in position 1?

If the roll unit is being used as a paper feeder and the basket is in position 1, the paper strip discarded by **Trim edge first** for borderless printing or paper loading may get drawn into the roll unit.

In this situation, refer to Example Basket Configurations and try another position.

➔ [Example Basket Configurations](#)

Paper Setting Problems

- **Paper widths with high transparency cannot be detected**
- **I want to know the paper types that can be used in this printer**
- **Estimated paper type does not match the loaded paper type**
- **The paper type that I want to print is not displayed on the Touch Screen**



Paper widths with high transparency cannot be detected



Check Is the platen dirty with ink?

Open the top cover and clean the entire platen area.

➔ [Cleaning Inside the Top Cover](#)



I want to know the paper types that can be used in this printer



For information about paper that can be used with this printer, refer to the paper information list.

➔ [Paper Information List](#)



Estimated paper type does not match the loaded paper type



Check 1 Is this paper being used for the first time?

If this is the first time to use the paper, it may not be selected correctly. In the media type selection, manually select the correct paper type.

Check 2 Is the paper you set genuine paper or recommended paper?

See [Using Paper Other Than Genuine Paper and feed confirmed Paper](#)

Check 3 Is there any unevenness in the gloss and color of the paper surface?

Some media types may not be suitable for paper type estimation. If the paper type is not recognized correctly, manually select the correct paper in the media type selection.



The paper type that I want to print is not displayed on the Touch Screen



If using a new paper type, start the Media Configuration Tool to get the latest media information.

➔ [Updating paper information](#)

Ink-related Problems

- **Printer consumes a lot of ink**
- **Ink Level Detection**
- **Does this printer support sub-ink tank system**



Printer consumes a lot of ink



Check 1 Are lots of full-color materials being printed?

In print jobs such as photos, images are filled with color. This consumes a lot of ink. This does not indicate a problem with the printer.

Check 2 Is **System Cleaning** being carried out frequently?

System Cleaning uses a lot of ink. This is normal. We recommend that you only carry out **System Cleaning** after the printer has been transported, if it has not been used for a long time, or if there is a problem with the Print head.

Check 3 You have just finished initial installation, when more ink is consumed to fill the system.

If using the printer for the first time, or using it after transport, the ink tank will supply an initial fill of ink to the Print head.

Although the amount of remaining ink may drop as a result, it does not indicate a problem.

Check 4 Is the Print head nozzle blocked?

Check for nozzle clogging.

➔ [Checking for Nozzle Clogging](#)



Ink Level Detection



The printer ink tank detects the amount of ink remaining to prevent running out of ink while printing and to avoid printer failure.

When using an ink tank refilled with ink, the function for detecting the remaining ink level may not operate properly and printing may stop. If you want to use an ink tank refilled with ink, you need to disable the function for detecting the remaining ink level.

▶▶▶ Important

- Printing with the ink level detection canceled may lead to printer damage and printing problems. Canon Inc. is not liable for any damage that may occur as a result of refilling ink.
- Once the function for detecting the remaining ink level is disabled, it cannot be restored for that ink tank. To restore the function for detecting the remaining ink level, replace the ink tank with a new ink tank for that printer.
- Repeatedly removing and inserting the same ink tank can cause the contacts between the ink tank and printer to malfunction, ink may leak from the ink tank, and the printer may become damaged.

Releasing ink level detection

Ink level detection will be deactivated if you load ink tanks once emptied.

If "The above ink tank may be an ink tank that ran out of genuine Canon ink or a counterfeit Canon ink tank." appears on the touch screen, follow the steps below.

1. Move through the screens, performing the actions described in the messages that appear on the touch screen.
2. If an instruction to disable detection of remaining ink appears, touch **Stop** on the printer for at least 5 seconds, and then release it.

Ink level detection is now released.



Does this printer support sub-ink tank system



This printer supports hot-swap ink tank replacement.

Even if an ink tank becomes empty during printing, since a certain amount of ink always is stored in a sub-ink tank, you can replace the ink tank while printing.

➔ [Replacing Ink Tanks](#)

About Print Settings

- **How do I print without borders**
- **I want to easily create vertical or horizontal banners**
- **Can I perform duplex printing**
- **I want to perform enlargement printing**



How do I print without borders



If printing on roll paper, you can set borderless printing in the printer driver settings. (If printing on sheets, borderless printing is not possible)

- ➔ Printing without Edges Based on the Scenarios (Windows)
- ➔ [Printing without Edges Based on the Scenarios](#) (macOS)



I want to easily create vertical or horizontal banners



You can print originals that are in landscape (or portrait) orientation automatically enlarged to fit the roll width. This is an easy way to create vertical or horizontal banners.

- ➔ [Printing Hanging and Horizontal Banners \(Large-Format Printing\) \(Windows\)](#)
- ➔ [Printing Hanging and Horizontal Banners \(Large-Format Printing\) \(macOS\)](#)



Can I perform duplex printing



This printer cannot print double-sided.

An alternative to double-sided printing is to use the **Folded Duplex** function of the Windows software Free Layout plus, which prints two pages on one side, folds the sheet back from the center, and hangs it.

➔ [Laying Out Documents Freely Using Free Layout plus](#)



I want to perform enlargement printing



Use the printer driver to adjust the original to the paper size and width, or print enlarged or reduced by specifying a magnification factor.

- ➔ Scaled Printing (Windows)
- ➔ [Scaled Printing](#) (macOS)

List of Support Code for Error

Support codes appear on the PC when an error occurs.

Support codes are error identification numbers that appear alongside error messages.

If an error occurs, check the support code and follow the recommended steps to resolve the issue.

Support code displayed

- **1000 to 1ZZZ**

[1005](#) [100A](#) [100B](#) [100E](#) [100F](#) [1012](#)

[1018](#) [1019](#) [1021](#) [1022](#) [1023](#) [1024](#)

[1025](#) [1034](#) [1035](#) [1036](#) [1039](#) [1040](#)

[1051](#) [1052](#) [1054](#) [1056](#) [1057](#) [1058](#)

[1059](#) [1061](#) [1200](#) [1201](#) [1210](#) [1213](#)

[1214](#) [1300](#) [1306](#) [1317](#) [1318](#) [1322](#)

[1323](#) [1324](#) [1325](#) [1326](#) [1327](#) [1328](#)

[1329](#) [1401](#) [1403](#) [1408](#) [1409](#) [140A](#)

[140B](#) [140C](#) [140F](#) [1468](#) [1477](#) [1478](#)

[1480](#) [1481](#) [1485](#) [1492](#) [1494](#) [1495](#)

[1500](#) [1551](#) [1552](#) [1570](#) [1571](#) [1660](#)

[168B](#) [1720](#) [1721](#) [1722](#) [1730](#) [1731](#)

[1752](#) [1753](#) [1756](#) [1757](#) [1875](#)

- **2000 to 2ZZZ**

[2001](#) [2002](#) [2130](#) [2131](#) [2132](#)

- **3000 to 3ZZZ**

[3000](#) [3001](#) [3006](#) [3101](#) [3200](#) [3201](#)

[3250](#) [3306](#) [3311](#) [3312](#) [3313](#) [3314](#)

[3315](#) [3316](#) [3317](#) [3331](#) [3332](#) [3333](#)

[3334](#) [3335](#) [3336](#) [3338](#) [3341](#) [3350](#)

[3351](#) [3352](#) [3414](#) [3415](#) [3416](#) [3417](#)

[3418](#) [3419](#) [3420](#) [3421](#) [3422](#) [3423](#)

[3424](#) [3448](#) [3451](#)

• **4000 to 4ZZZ**

[4107](#) [4111](#) [4112](#) [4113](#) [4114](#) [4116](#)

[4117](#) [4119](#) [4120](#) [4121](#) [4122](#) [4801](#)

[4803](#) [4804](#) [4805](#) [4806](#) [4808](#) [4900](#)

[4901](#) [4903](#) [4905](#) [4909](#) [4910](#) [4911](#)

[4913](#) [4920](#) [4922](#) [4924](#) [4925](#) [4926](#)

[4927](#) [4931](#) [4932](#) [4933](#) [4934](#) [4935](#)

[4950](#) [4952](#) [4953](#) [4954](#) [4955](#) [4956](#)

• **5000 to 5ZZZ**

[5200](#) [5A60](#) [5B10](#) [5B16](#) [5B20](#)

[5B21](#) [5C00](#)

• **6000 to 6ZZZ**

[6502](#) [6700](#) [6702](#) [6820](#) [6900](#) [6901](#)

[6902](#) [6910](#) [6920](#) [6921](#) [6930](#) [6931](#)

[6932](#) [6933](#) [6940](#) [6941](#) [6942](#) [6943](#)

[6944](#) [6945](#) [6946](#)

• **7000 to 7ZZZ**

[7050](#) [7051](#) [7052](#)

• **8000 to 8ZZZ**

[8200](#)

• **9000 to 9ZZZ**

[9000](#) [9110](#)

• **A000 to ZZZZ**

[B20A](#) [B510](#)

1005

Cause

You have attempted to print on a sheet, but no sheet is loaded.

What to Do

Check the media size and type for the print job on the touch screen, and then tap **OK**.

- **Continuing to print**

Tap **Load paper**, and then load the paper.

➔ [Loading Sheets in the Printer](#)

- **Stopping printing**

To stop printing, tap **Cancel** or **Stop** on the touch screen.

100A

Cause

You have attempted to print from Roll 1, but no roll is loaded.

What to Do

Tap **Load paper** on the touch screen, and then load the paper roll and print.

➔ [Loading Rolls in the Printer](#)

▶▶ Note

- To stop printing, tap **Cancel** or **Stop** on the touch screen.

100B

Cause

Tried to print from Roll 2 but no paper roll has been loaded.

What to Do

Tap **Load paper** on the touch screen, and then load the paper roll and print.

➔ [Loading Roll Paper in the Roll Unit](#)

▶▶ Note

- To stop printing, tap **Cancel** or **Stop** on the touch screen.

100E

Cause

A printer error has occurred.

What to Do

Turn off the power, wait a moment, and then turn it back on.

If the error appears again, make a note of the detailed error code (ECxx-xxxx) that appears on the touch screen, and then turn off the power and contact a Canon customer service center.

Detailed error codes

EC16-202E

100F

Cause

A printer error has occurred.

What to Do

Turn off the power, wait a moment, and then turn it back on.

If the error appears again, make a note of the detailed error code (ECxx-xxxx) that appears on the touch screen, and then turn off the power and contact a Canon customer service center.

Detailed error codes

EC17-202F

1012

Cause

You have attempted to print on a sheet, but no sheet is loaded.

What to Do

Tap **Load paper** on the touch screen, and then load cut paper and print.

➔ [Loading Sheets in the Printer](#)

▶▶ Note

- To stop printing, tap **Cancel** or **Stop** on the touch screen.

1018

Cause

Roll 1 feeder has not been calibrated.

What to Do

Calibrating, please remove the roll holder from the printer.

➔ [Removing the Roll from the Printer](#)

1019

Cause

The Roll 2 feeder has not been calibrated.

What to Do

Calibrating, please remove the roll holder on the roll unit.

➔ [Removing Roll Paper from the Roll Unit](#)

Cause

The printer has received a print job longer than the amount of roll paper left.

What to Do

- **Continuing to print**

To continue printing, tap **Print with the loaded paper.** on the touch screen.

However, the roll paper may run out during the print job and you may not be able to print all of the document.

- **Replacing paper**

Tap **Replace the paper and print** and print on the touch screen.

Change the **Paper Source** in the printer driver, or replace the paper with paper of the right length for the print job, and then try again.

If using the Media Take-up Unit, tap **Cancel** on the touch screen to stop printing.

Remove the printed paper from the Media Take-up Unit, replace the paper with paper of the right length for the print job, and then try again.

➔ [Removing the Roll from the Printer](#)

➔ [Loading Rolls in the Printer](#)

➔ [Removing Printed Paper from the Roll Unit](#)

- **Stopping printing**

To stop printing, tap **Cancel** or **Stop** on the touch screen.

Cause

Received print job that is longer than paper length remaining on Roll 1.

What to Do

- **Continuing to print**

To continue printing, tap **Print with the loaded paper.** on the touch screen.

However, the roll paper may run out during the print job and you may not be able to print all of the document.

- **Replacing paper**

Tap **Replace the paper and print** on the touch screen.

Change the **Paper Source** in the printer driver, or replace the paper with paper of the right length for the print job, and then try again.

➔ [Removing the Roll from the Printer](#)

➔ [Loading Rolls in the Printer](#)

- **Stopping printing**

To stop printing, tap **Cancel** or **Stop** on the touch screen.

Cause

Received print job that is longer than paper length remaining on Roll 2.

What to Do

- **Continuing to print**

To continue printing, tap **Print with the loaded paper.** on the touch screen.

However, the roll paper may run out during the print job and you may not be able to print all of the document.

- **Replacing paper**

Tap **Replace the paper and print** on the touch screen.

Change the **Paper Source** in the printer driver, or replace the paper with paper of the right length for the print job, and then try again.

➔ [Removing Roll Paper from the Roll Unit](#)

➔ [Loading Roll Paper in the Roll Unit](#)

- **Stopping printing**

To stop printing, tap **Cancel** or **Stop** on the touch screen.

Cause

Possible causes include the following.

- Roll paper is empty in Roll 1.
- There is remaining roll paper in Roll 1, but because it could not be advanced, it could not be detected.

What to Do

• The roll paper has run out

Follow the steps below to replace the used roll with a new roll of the same type and size.

1. Lift up the release lever and remove the roll paper.

➔ [Removing the Roll from the Printer](#)

2. Load the new roll.

➔ [Loading Rolls in the Printer](#)

3. If "**There is a job which has not been printed yet. Do you want to print this job?**" appears on the touch screen, tap **Yes**.

Printing will resume, starting from the page on which the error occurred.

• Feed stopped because the end of the paper roll is attached to the core with tape

Remove the used roll paper and insert a new roll paper.

➔ [Removing the Roll from the Printer](#)

➔ [Loading Rolls in the Printer](#)

• Feed stopped because the remaining paper roll is too heavy

It may be helpful to change the printing mode, which will change the paper feed timing.

If using Windows, select a higher **Print Quality** setting under **Advanced Settings** in the printer driver.

If using macOS, select **Quality & Media** in the printer driver, and then select a higher **Print Quality** setting.

➔ [Setting the Print Quality Level \(Custom\) \(Windows\)](#)

➔ [Setting the Print Quality Level \(Custom\) \(macOS\)](#)

▶▶▶ Note

- To stop printing, tap **Stop**.

1025

Cause

Roll paper in Roll 2 is empty.

What to Do

Follow the steps below to replace the used roll with a new roll of the same type and size.

1. Lift up the release lever and remove the roll paper.

➡ [Removing Roll Paper from the Roll Unit](#)

2. Load the new roll.

➡ [Loading Roll Paper in the Roll Unit](#)

3. If "**There is a job which has not been printed yet. Do you want to print this job?**" appears on the touch screen, tap **Yes**.

Printing will resume, starting from the page on which the error occurred.

▶▶ Note

- To stop printing, tap **Stop**.

1034

Cause

No roll is loaded in printer.

What to Do

- **Continuing to print**

Load a roll in the printer and print.

If a roll is loaded in the printer, feed the roll paper manually.

➔ [Loading Rolls in the Printer](#)

- **Stopping printing**

To stop printing, tap **OK** on the touch screen.

▶▶ Note

- When **Roll paper auto feed** is set to **Disable**, roll paper is not fed automatically. Check the settings.

1035

Cause

No roll is loaded in roll unit.

What to Do

- **Continuing to print**

Load a roll in the roll unit and print.

If a roll is loaded in the roll unit, feed the roll paper manually.

➔ [Loading Roll Paper in the Roll Unit](#)

- **Stopping printing**

To stop printing, tap **OK** on the touch screen.

▶▶ Note

- When **Roll paper auto feed** is set to **Disable**, roll paper is not fed automatically. Check the settings.

1036

Cause

Printer tried printing from Roll 2, but roll unit is not installed.

What to Do

Check if the roll unit is properly installed on the printer following the steps below.

1. Tap **OK** on the touch screen to stop printing.
2. Turn off the power and make sure the roll unit is properly installed on the printer.

▶▶ Note

- For instructions on installing the roll unit, see the Roll Unit Setup Guide provided with the roll unit.
- Make sure the roll unit's connection cable is inserted all the way in.

If the error appears again, the printer may be damaged. Contact a Canon customer service center.

1039

Cause

Unsupported roll unit is installed on printer.

What to Do

Turn off the power and remove the roll unit.

Check the model number of the roll unit. Install a roll unit supported by the printer.

➔ [Roll Unit](#)

▶▶ Note

- For instructions on installing the roll unit, see the Roll Unit Setup Guide provided with the roll unit.

If the error appears again, the printer may be damaged. Contact a Canon customer service center.

1040

Cause

Unsupported roll unit is installed on printer.

What to Do

Turn off the power and remove the roll unit.

Check the model number of the roll unit. Install a roll unit supported by the printer.

➔ [Roll Unit](#)

▶▶ Note

- For instructions on installing the roll unit, see the Roll Unit Setup Guide provided with the roll unit.

If the error appears again, the printer may be damaged. Contact a Canon customer service center.

1051

Cause

The media type specified in the printer driver is not the same as the media type loaded in the printer.

What to Do

You can continue to print, but note that this error may cause problems in the printing results.

1052

Cause

The width of the roll paper set in **Fit Roll Paper Width** in the printer driver is not the same as the width of the roll paper loaded in the printer.

What to Do

You can continue to print, but note that this error may cause problems in the printing results.

1054

Cause

The paper in the printer is smaller than the paper size set in the printer driver.

What to Do

You can continue to print, but note that this error may cause problems in the printing results.

1056

Cause

The paper position is not suitable for borderless printing.

What to Do

You can continue to print, but note that this error may cause problems in the printing results.

1057

Cause

The paper position is not suitable for borderless printing.

What to Do

You can continue to print, but note that this error may cause problems in the printing results.

1058

Cause

Roll paper in Roll 1 has almost run out.

What to Do

Printing will continue. Replace the roll in the printer with one that has enough paper for printing as soon as possible.

➔ [Removing the Roll from the Printer](#)

➔ [Loading Rolls in the Printer](#)

➤➤ Note

- To stop printing, tap **Stop**.

1059

Cause

Roll paper in Roll 2 has almost run out.

What to Do

Printing will continue. Replace the roll in the roll unit with one that has enough paper for printing as soon as possible.

➔ [Removing Roll Paper from the Roll Unit](#)

➔ [Loading Roll Paper in the Roll Unit](#)

➤➤ Note

- To stop printing, tap **Stop**.

Cause

The media type specified in the print job is not the same as the media type loaded in the printer.

What to Do

Tap **OK** on the touch screen to go to the next screen.

Check the displayed media type and size, and tap **OK**.

- **Printing again according to the media type**

Follow the steps below to match the media type in the print job and the media type loaded in the printer.

- **Changing the media type in the print job**

1. Tap **Cancel** to stop printing.
2. Change the media type in the print job settings to the media type loaded in the printer, and then try again.

- ➡ [Loading Rolls in the Printer](#)

- ➡ [Loading Sheets in the Printer](#)

- **Replacing paper**

1. Tap **Replace the paper and print**.
2. Load the paper with the media type specified in the print job, and then try again.

- ➡ [Loading Rolls in the Printer](#)

- ➡ [Loading Sheets in the Printer](#)

- **Printing with the current print settings**

To continue printing, tap **Print with the loaded paper** on the touch screen.

However, note that this error may cause paper jams and affect the printing quality.

1200

Cause

Top cover or print head lock lever is open.

What to Do

Open the top cover and make sure the print head lock lever is closed properly.

Make sure there are no foreign objects caught in the top cover, and then close the top cover.

If this error appears again, close the top cover, turn the power off, wait a moment, and then turn the power back on.

▶▶ Note

- If installing a print head, close the top cover after finishing.

1201

Cause

The ink tank cover is open.

What to Do

Close the ink tank cover.

1210

Cause

The ink tank cover is open.

What to Do

Close the ink tank cover.

1213

Cause

Release lever is lifted up.

What to Do

Lower the release lever.

If the error occurs again, turn off the printer and wait a while before restoring power.

1214

Cause

A printer error has occurred.

What to Do

Turn off the power, wait a moment, and then turn it back on.

If the error appears again, make a note of the detailed error code (ECxx-xxxx) that appears on the touch screen, and then turn off the power and contact a Canon customer service center.

Detailed error codes

EC19-2F21 EC51-2F38

Cause

Paper jammed inside the printer while printing.

What to Do

Follow these steps below to remove jammed paper.

1. Lift up the release lever and remove the jammed paper.

- ➡ [Remove Jammed Roll Paper](#)
- ➡ [Remove a Jammed Sheet](#)

2. Load the paper.

- ➡ [Loading Rolls in the Printer](#)
- ➡ [Loading Roll Paper in the Roll Unit](#)
- ➡ [Loading Sheets in the Printer](#)

3. If "**There is a job which has not been printed yet. Do you want to print this job?**" appears on the touch screen, tap **Yes**.

Printing will resume, starting from the page on which the error occurred.

If the error appears again, the printer may be damaged. Contact a Canon customer service center.

Cause

A print job for rolls was received when a sheet is loaded.

What to Do

Follow these steps to load and print on a roll.

1. To remove the cut paper, tap **Remove paper** on the touch screen.

➔ [Removing Sheets](#)

2. Load a new roll.

➔ [Loading Rolls in the Printer](#)

➔ [Loading Roll Paper in the Roll Unit](#)

▶▶ Note

- To stop printing, tap **Cancel** or **Stop** on the touch screen.

Cause

Paper loaded crooked was detected when the paper was advanced.

What to Do

Lift up the release lever and reload the paper.

- ➔ [Loading Rolls in the Printer](#)
- ➔ [Loading Roll Paper in the Roll Unit](#)
- ➔ [Loading Sheets in the Printer](#)

If this error appears again even after reloading the paper roll, remove the roll holder from the printer, insert the paper roll firmly into the roll holder until it is up against the flange, and then insert the roll holder into the printer.

- ➔ [Loading Rolls on the Roll Holder](#)

▶▶▶ Important

- If this message continues to appear even after taking the steps above, or if you do not want this message to appear, set **Skew detection accuracy** in the printer menu to **OFF** or **Loose**. However, note that the paper will be printed skewed, which could cause paper jams and abnormal print results, or dirty the platen and the reverse of the next printed sheet.

1318

Cause

A printer error has occurred.

What to Do

Turn off the power, wait a moment, and then turn it back on.

If the error appears again, make a note of the detailed error code (ECxx-xxxx) that appears on the touch screen, and then turn off the power and contact a Canon customer service center.

Detailed error codes

EC0F-2F93

Cause

Cannot detect paper size because paper is not in the correct position or because curled paper has been loaded.

What to Do

Lift up the release lever and reload the paper.

- ➔ [Loading Rolls in the Printer](#)
- ➔ [Loading Roll Paper in the Roll Unit](#)
- ➔ [Loading Sheets in the Printer](#)

If "**There is a job which has not been printed yet. Do you want to print this job?**" appears on the touch screen, tap **Yes**.

Printing will resume, starting from the page on which the error occurred.

▶▶▶ Note

- If this error appears again even after reloading the paper roll, remove the roll holder from the printer, insert the paper roll firmly into the roll holder until it is up against the flange, and then insert the roll holder into the printer.
 - ➔ [Loading Rolls on the Roll Holder](#)
- This error might also appear if the platen has been dirtied by ink or another substance, or if the size of clear film could not be detected. In this case, open the top cover and clean the entire platen area.
 - ➔ [Cleaning Inside the Top Cover](#)

1323

Cause

An unsuitable paper size has been loaded.

What to Do

Lift up the release lever and reload paper of suitable size.

➔ [Paper Sizes](#)

➤➤ Note

- Load unused A4/letter size or larger paper if printing calibration and nozzle check patterns. Each calibration may take several sheets of paper.

Cause

A print job for printing on sheets was sent when a roll is loaded.

What to Do

Follow the steps below to print again.

1. Tap **Remove paper** on the touch screen to stop printing.
2. Remove the paper roll, load cut paper of the size and type specified in the printer driver, and then try again.
 - ➔ [Removing the Roll from the Printer](#)
 - ➔ [Removing Roll Paper from the Roll Unit](#)
 - ➔ [Loading Sheets in the Printer](#)

▶▶ Note

- To stop printing, tap **Cancel** or **Stop** on the touch screen.

1325

Cause

Received cut paper print data when using roll unit on Media Take-up Unit.

What to Do

Follow the steps below to print again.

1. Tap **Cancel** on the touch screen to stop printing.
2. Remove the paper roll, load cut paper of the size and type specified in the printer driver, and then try again.
 - ➡ [Removing Printed Paper from the Roll Unit](#)
 - ➡ [Loading Sheets in the Printer](#)

Cause

Printer could not feed roll.

What to Do

Fully rewind the roll in the printer manually, check the following, and then tap **OK** on the touch screen.

- Is the edge of the roll paper at a slant or folded?

If the edge of the roll paper is at a slant or is folded, use scissors or a cutting tool to cut it away and straighten the edge of the roll paper.

- Is the roll paper loaded in the opposite orientation?

Load the roll paper in correct orientation.

- Is the roll paper loose?

If the roll paper is loose, remove the slack before loading the roll paper.

- Is the paper wrinkled or curled?

If the paper is wrinkled or curled, straighten it out before loading it.

To continue paper feeding, tap **OK** on the touch screen and feed the paper manually.

➔ [Loading Rolls in the Printer](#)

Cause

Printer could not feed roll paper from roll unit.

What to Do

Fully rewind the roll paper in the roll unit manually, check the following, and then tap **OK** on the touch screen.

- Is the edge of the roll paper at a slant or folded?

If the edge of the roll paper is at a slant or is folded, use scissors or a cutting tool to cut it away and straighten the edge of the roll paper.

- Is the roll paper loaded in the opposite orientation?

Load the roll paper in correct orientation.

- Is the roll paper loose?

If the roll paper is loose, remove the slack before loading the roll paper.

- Is the paper wrinkled or curled?

If the paper is wrinkled or curled, straighten it out before loading it.

To continue paper feeding, tap **OK** on the touch screen and feed the paper manually.

➔ [Loading Roll Paper in the Roll Unit](#)

Cause

Roll paper jammed in the printer.

What to Do

Fully rewind the roll in the printer manually, check the following, and then tap **OK** on the touch screen.

- Is the edge of the roll paper at a slant or folded?

If the edge of the roll paper is at a slant or is folded, use scissors or a cutting tool to cut it away and straighten the edge of the roll paper.

- Is the roll paper loaded in the opposite orientation?

Load the roll paper in correct orientation.

- Is the roll paper loose?

If the roll paper is loose, remove the slack before loading the roll paper.

- Is the paper wrinkled or curled?

If the paper is wrinkled or curled, straighten it out before loading it.

To continue paper feeding, tap **OK** on the touch screen and feed paper manually.

➔ [Loading Rolls in the Printer](#)

If the error appears again, the printer may be damaged. Contact a Canon customer service center.

Cause

Roll paper jammed in roll unit.

What to Do

Fully rewind the roll paper in the roll unit manually, check the following, and then tap **OK** on the touch screen.

- Is the edge of the roll paper at a slant or folded?

If the edge of the roll paper is at a slant or is folded, use scissors or a cutting tool to cut it away and straighten the edge of the roll paper.

- Is the roll paper loaded in the opposite orientation?

Load the roll paper in correct orientation.

- Is the roll paper loose?

If the roll paper is loose, remove the slack before loading the roll paper.

- Is the paper wrinkled or curled?

If the paper is wrinkled or curled, straighten it out before loading it.

To continue paper feeding, tap **OK** on the touch screen and feed paper manually.

➔ [Loading Roll Paper in the Roll Unit](#)

If the error appears again, the printer may be damaged. Contact a Canon customer service center.

1401

Cause

Failed to recognize print head.

What to Do

Open the top cover and reattach the print head.

➔ [Replacing the Print Head](#)

1403

Cause

There is a problem with the print head.

What to Do

Tap **OK** on the touch screen, and then replace the current print head with a new one.

➔ [Replacing the Print Head](#)

If you do not have a replacement print head ready, turn off the power and replace the print head once you have the new one.

1408

Cause

There is a problem with the print head.

What to Do

Tap **OK** on the touch screen, and then replace the current print head with a new one.

➔ [Replacing the Print Head](#)

If you do not have a replacement print head ready, turn off the power and replace the print head once you have the new one.

1409

Cause

There is a problem with the print head.

What to Do

Tap **OK** on the touch screen, and then replace the current print head with a new one.

➔ [Replacing the Print Head](#)

If you do not have a replacement print head ready, turn off the power and replace the print head once you have the new one.

140A

Cause

There is a problem with the print head.

What to Do

Tap **OK** on the touch screen, and then replace the current print head with a new one.

➔ [Replacing the Print Head](#)

If you do not have a replacement print head ready, turn off the power and replace the print head once you have the new one.

140B

Cause

Failed to recognize print head.

What to Do

Open the top cover and reattach the print head.

➔ [Replacing the Print Head](#)

140C

Cause

There is a problem with the print head.

What to Do

Turn off the power, wait a moment, and then turn it back on.

140F

Cause

There is a problem with the print head.

What to Do

Tap **OK** on the touch screen, and then replace the current print head with a new one.

➔ [Replacing the Print Head](#)

If you do not have a replacement print head ready, turn off the power and replace the print head once you have the new one.

1468

Cause

A printer error has occurred.

What to Do

Turn off the power, wait a moment, and then turn it back on.

If the error appears again, make a note of the detailed error code (ECxx-xxxx) that appears on the touch screen, and then turn off the power and contact a Canon customer service center.

Detailed error codes

EC55-2F24

1477

Cause

There is a problem with the print head.

What to Do

Open the top cover and replace the print head with a new one.

➔ [Replacing the Print Head](#)

1478

Cause

There is a problem with the print head.

What to Do

Tap **OK** on the touch screen, and then replace the current print head with a new one.

➔ [Replacing the Print Head](#)

If you do not have a replacement print head ready, turn off the power and replace the print head once you have the new one.

1480

Cause

The attached print head was previously used in a different model.

What to Do

Attach the correct print head.

➔ [Replacing the Print Head](#)

1481

Cause

The attached print head was previously used in a model that uses a different ink set.

What to Do

Attach the correct print head.

➔ [Replacing the Print Head](#)

1485

Cause

Cannot use attached print head.

What to Do

Attach the correct print head.

➔ [Replacing the Print Head](#)

1492

Cause

A printer error has occurred.

What to Do

Turn off the power, wait a moment, and then turn it back on.

If the error appears again, make a note of the detailed error code (ECxx-xxxx) that appears on the touch screen, and then turn off the power and contact a Canon customer service center.

Detailed error codes

EC21-2F44 EC3F-2F40 EC3F-2F41

1494

Cause

There may be a problem with the print head.

What to Do

Turn off the power, wait a moment, and then turn it back on.

If the error appears again, remove and reattach the print head.

➔ [Replacing the Print Head](#)

If that does not get rid of the error, replace the print head with a new one.

Cause

The print head nozzle is blocked.

What to Do

Follow the steps below to clean the print head.

1. Tap **Cancel** on the touch screen to stop printing.
2. Clean the print head.

➔ [Cleaning the Print Head](#)

If this message still appears when printing, replace the print head.

➔ [Replacing the Print Head](#)

▶▶ Important

- To continue printing, use the touch screen and tap **Continue printing**. However, the print results may not be satisfactory.

1500

Cause

The ink in the ink tank is running low.

What to Do

Prepare a new ink tank.

1551

Cause

A genuine Canon ink tank with a history of past use has been detected.

What to Do

To dismiss the message, tap **OK** on the touch screen.

1552

Cause

A genuine Canon ink tank has been inserted.

What to Do

To dismiss the message, tap **OK** on the touch screen.

1570

Cause

The ink in the ink tank has run out.

What to Do

Open the ink tank cover, and then replace the ink tank before the ink in the sub-ink tank of this printer becomes insufficient.

➔ [Replacing Ink Tanks](#)

▶▶ Note

- You can replace the ink tank even while printing.

1571

Cause

Ink tank removed during printing.

What to Do

If replacing the ink tank, insert a new ink tank.

➔ [Replacing Ink Tanks](#)

1660

Cause

Ink tank not inserted.

What to Do

Insert the ink tank correctly.

➔ [Replacing Ink Tanks](#)

168B

Cause

The ink tank cannot be recognized.

Printing cannot be executed because the ink tank may not be compatible with this printer.

What to Do

Install the appropriate ink tank.

1720

Cause

The maintenance cartridge is full.

It needs to be replaced.

What to Do

Replace the maintenance cartridge.

➔ [Replacing the Maintenance Cartridge](#)

1721

Cause

The maintenance cartridge is not installed.

What to Do

Install the maintenance cartridge.

➔ [Replacing the Maintenance Cartridge](#)

1722

Cause

Incorrect type of maintenance cartridge.

What to Do

Insert the correct maintenance cartridge.

➔ [Replacing the Maintenance Cartridge](#)

If this error continues to appear, contact a Canon customer service center.

Cause

The ink tank may be an ink tank that ran out of genuine Canon ink or a counterfeit Canon ink tank.

What to Do

To print, you must replace the ink tank or disable the function for detecting the remaining ink level.

➔ [Replacing Ink Tanks](#)

To disable the function for detecting the remaining ink level, touch **Stop** on the printer for at least 5 seconds, and then release it.

By this operation, the fact that you have disabled the function for detecting the remaining ink level will be memorized. Please be advised that Canon shall not be liable for any malfunction or trouble caused by continuation of printing under the ink out condition or by using refilled ink tanks.

▶▶▶ Note

- If the function for detecting the remaining ink level is disabled, the ink tank in gray is displayed on the touch screen when checking the current ink level.

To report the counterfeit ink tank, access Canon website from the following link.

➔ [Report Counterfeit](#)

Cause

Non-genuine Canon ink tank has been detected.

What to Do

To print, you must replace the ink tank or disable the function for detecting the remaining ink level.

➔ [Replacing Ink Tanks](#)

To disable the function for detecting the remaining ink level, touch **Stop** on the printer for at least 5 seconds, and then release it.

By this operation, the fact that you have disabled the function for detecting the remaining ink level will be memorized. Please be advised that Canon shall not be liable for any malfunction or trouble caused by using a non-genuine Canon ink tank.

▶▶▶ Note

- If the function for detecting the remaining ink level is disabled, the ink tank in gray is displayed on the touch screen when checking the current ink level.

To report the counterfeit ink tank, access Canon website from the following link.

➔ [Report Counterfeit](#)

1752

Cause

The ink has run out.

What to Do

Open the ink tank cover, and then replace the ink tank.

➔ [Replacing Ink Tanks](#)

Cause

The remaining level of the ink cannot be correctly detected.

What to Do

Replace the ink tank. Printing will restart.

➔ [Replacing Ink Tanks](#)

An ink tank that was once empty is installed.

If you want to continue printing, you need to disable the function for detecting the remaining ink level.

To disable this function, touch **Stop** on the printer for at least 5 seconds, and then release it.

With this operation, disabling the function for detecting the remaining ink level is memorized.

Please be advised that Canon shall not be liable for any malfunction or trouble caused by continuation of printing under the ink out condition or by using refilled ink tanks.

1756

Cause

The ink may become insufficient.

What to Do

To perform the next process or to continue the specified process, replace the ink tank.

➔ [Replacing Ink Tanks](#)

1757

Cause

Cannot fill sub ink tank.

What to Do

Check the touch screen, remove the ink tank for the affected color, and then reinsert it.

If the inserted ink tank is empty, replace it with a new ink tank.

➔ [Replacing Ink Tanks](#)

1875

Cause

Attempted to print on roll unit roll paper, but roll unit is not powered on or has been removed.

What to Do

Turn off the power and check the connection with the roll unit.

For instructions on installing the roll unit, see the Roll Unit Setup Guide provided with the roll unit.

2001

Cause

An incompatible device is connected.

What to Do

Check the device connected to the USB flash drive port.

Only USB flash drive can be connected to this device for direct printing.

2002

Cause

An incompatible USB hub is connected.

What to Do

If USB flash drive is connected to this device through a USB hub, remove the USB hub.

Connect the USB flash drive directly to this device.

Cause

The roll paper width set in the print job is not the same as the width of the roll paper in the printer.

What to Do

Tap **OK** on the touch screen to go to the next screen.

Check the media type and size that appear and tap **OK**.

- **Stopping printing**

Tap **Cancel** or **Stop** on the touch screen.

- **Replacing the roll paper**

Follow the steps below to replace the paper with roll paper of the width set in the printer driver.

1. Tap **Replace the paper and print**, then remove the roll paper.

- ➔ [Removing the Roll from the Printer](#)

- ➔ [Removing Roll Paper from the Roll Unit](#)

2. Replace the paper with paper of the width set in the printer driver.

- ➔ [Loading Rolls in the Printer](#)

- ➔ [Loading Roll Paper in the Roll Unit](#)

Printing begins.

- **Printing without changes**

Tap **Print with the loaded paper..**

However, note that this error may cause paper jams and affect the printing quality.

▶▶▶ Note

- To change print settings in Windows, select **Fit Roll Paper Width** in the printer driver and set the roll paper width in the dialog box that appears.
- To change print settings in macOS, open the printer driver and select **Fit Roll Paper Width**, and then set the roll paper width in that panel to the width of the paper loaded in the printer.
- To suppress this message, set **Detect paper setting mismatch** in the touch screen menu to **Do not detect**. However, note that this error may affect the printing quality.

- ➔ [Menu Structure](#)

Cause

The roll paper loaded in the printer is narrower than the roll paper width in the print job.

What to Do

Tap **OK** on the touch screen to go to the next screen.

Check the media type and size that appear and tap **OK**.

- **Stopping printing**

Tap **Cancel** or **Stop** on the touch screen.

- **Replacing the roll paper**

Follow the steps below to replace the paper with roll paper of the width specified in the print job paper size settings.

1. Tap **Replace the paper and print**, then remove the roll paper.

- ➔ [Removing the Roll from the Printer](#)

- ➔ [Removing Roll Paper from the Roll Unit](#)

2. Replace the paper with paper of the width set in the printer driver.

- ➔ [Loading Rolls in the Printer](#)

- ➔ [Loading Roll Paper in the Roll Unit](#)

Printing begins.

- **Printing without changes**

Tap **Print with the loaded paper**.

However, note that this error may cause paper jams and affect the printing quality.

▶▶▶ Note

- To change print settings in Windows, select **Fit Roll Paper Width** in the printer driver and set the roll paper width in the dialog box that appears.
- To change print settings in macOS, open the printer driver and select **Fit Roll Paper Width**, and then set the roll paper width in that panel to the width of the paper loaded in the printer.
- To suppress this message, set **Detect paper setting mismatch** in the touch screen menu to **Do not detect**. However, note that this error may affect the printing quality.

- ➔ [Menu Structure](#)

Cause

Cannot print internal printer data, such as test prints, for the following reasons.

- The paper roll loaded in the printer is too small.
- The cut paper loaded in the printer is the wrong size or type.

What to Do

- **Roll**

Tap **Replace the paper and print** on the touch screen, or lift up the release lever and replace the paper with paper of the correct size.

To stop printing, tap **Cancel** or **Stop** on the touch screen.

- **Sheet**

Lift up the release lever and load paper of the same size and type as the first page.

To stop printing, tap **Stop**.

3000

Cause

The print head has not been calibrated.

What to Do

Print Head Alignment is recommended.

➔ [Automatic Adjustment to Straighten Lines and Align Colors](#)

➤➤ Note

- This message will appear until **Print Head Alignment** is carried out.

3001

Cause

The print head nozzle is becoming blocked.

What to Do

Check the printed materials.

If the printed materials are scratched, clean the print head.

➔ [Cleaning the Print Head](#)

3006

Cause

The print head is under conditions where the adjustment of the print head is recommended.

What to Do

Print Head Alignment is recommended.

➔ [Automatic Adjustment to Straighten Lines and Align Colors](#)

▶▶ Note

- This message will appear until **Print Head Alignment** is carried out.

Cause

Common calibration or unique calibration is now recommended.

This message appears when the **Calibration guide settings** is set to **Enable** and any of the following apply.

- The printer is loaded with a media type not suitable for **Color calibration**, and the specified conditions have been met since the last time common calibration was carried out.
- The printer is loaded with a media type suitable for **Color calibration**, but there are no **Color calibration** results for that media type and the specified conditions have been met since the last time common calibration was carried out.
- The printer is loaded with a media type suitable for **Color calibration**, but there are no **Color calibration** results for that media type and also no common calibration results.

What to Do

Carry out common calibration as needed.

➔ [Performing Color Calibration](#)

➤➤ Note

- To suppress this message, set the **Calibration guide settings** in the touch screen menu to **Disable**.

➔ [Menu Structure](#)

3200

Cause

It is almost time to replace consumables for which service is required.

What to Do

This can be used for a little while, until the message "**A part needs to be replaced.**" appears.

Contact your Canon dealer for assistance.

3201

Cause

It is past the recommended time to replace consumables for which service is required.

What to Do

Contact your Canon dealer for assistance.

3250

Cause

The maintenance cartridge is almost full.

What to Do

Prepare a new maintenance cartridge because an error may occur if you continue to use the printer while the maintenance cartridge is full.

➔ [Replacing the Maintenance Cartridge](#)

Cause

Media information cannot be recognized because the printer media information is corrupt.

What to Do

Start the Media Configuration Tool, and then recover the media information.

➔ [Media Configuration Tool Guide](#)

To set the Media Configuration Tool to recovery mode, open the Media Configuration Tool, select this device and then click **OK**.

Select and load the media information backup file.

If you do not have a media information backup file, contact a Canon customer service center.

3311

Cause

Incorrect print data.

Illegal number of parameters.

What to Do

Defective print data, please check the print results.

If using printing software such as RIP (Raster Image Processor), contact the software manufacturer.

3312

Cause

Incorrect print data.

Required items have been omitted.

What to Do

Defective print data, please check the print results.

If using printing software such as RIP (Raster Image Processor), contact the software manufacturer.

3313

Cause

Incorrect print data.

Data out of range.

What to Do

Defective print data, please check the print results.

If using printing software such as RIP (Raster Image Processor), contact the software manufacturer.

3314

Cause

Incorrect print data.

Resolution value out of range.

What to Do

Defective print data, please check the print results.

If using printing software such as RIP (Raster Image Processor), contact the software manufacturer.

3315

Cause

Incorrect print data.

Compression method value out of range.

What to Do

Defective print data, please check the print results.

If using printing software such as RIP (Raster Image Processor), contact the software manufacturer.

3316

Cause

Incorrect print data.

Incorrect data formatting (color sequence, bit count).

What to Do

Defective print data, please check the print results.

If using printing software such as RIP (Raster Image Processor), contact the software manufacturer.

3317

Cause

Incorrect print data.

Illegal combination of resolution and image data format.

What to Do

Defective print data, please check the print results.

If using printing software such as RIP (Raster Image Processor), contact the software manufacturer.

3331

Cause

Print results may be abnormal as there is a large volume of print data.

What to Do

Check the print job.

Cause

Unsupported JPEG data format.

What to Do

Check the JPEG data.

Printable file formats are as follows.

- **Files which conforms to JFIF 1.02**

- Processing method: Basic DCT
- Color mode: RGB/GrayScale
- Number of colors: 24bit/8bit
- Number of pixels: 38400 or less vertically and horizontally

* Does not support some samplings.

Cause

Unsupported JPEG data format.

What to Do

Check the JPEG data.

Printable file formats are as follows.

- **Files which conforms to JFIF 1.02**

- Processing method: Basic DCT
- Color mode: RGB/GrayScale
- Number of colors: 24bit/8bit
- Number of pixels: 38400 or less vertically and horizontally

* Does not support some samplings.

3334

Cause

PDF data is print protected.

What to Do

Open the PDF file in Adobe Acrobat and make sure it can be printed.

3335

Cause

Corrupt PDF file.

What to Do

Open the PDF file in Adobe Acrobat and check it.

The file can also be printed from Acrobat.

3336

Cause

Too many fonts are used in the PDF file, causing a memory shortage.

Printing will continue but some incorrect characters will be printed.

What to Do

Print the PDF file from a computer or convert the PDF file to JPEG and then print it.

3338

Cause

Resolution of JPEG data and printer settings are mismatched.

What to Do

Check the print results.

When the print results have problems, print using a printer driver.

3341

Cause

Print data including the image processing table was sent.

What to Do

Print data that includes the image processing table cannot be printed.

If using printing software such as RIP (Raster Image Processor), contact the software manufacturer.

3350

Cause

Free space on the personal box on the printer hard disk is running low.

What to Do

Delete unneeded jobs stored in personal boxes.

➔ [Deleting Saved Jobs](#)

3351

Cause

100 jobs are stored in the personal box.

What to Do

Delete any unneeded jobs saved in the personal box.

➔ [Deleting Saved Jobs](#)

3352

Cause

The printer hard disk is full, so the job will only be printed.

(The print job will not be saved to the hard disk.)

What to Do

To save the print job, delete any unneeded jobs saved in the personal box.

➔ [Deleting Saved Jobs](#)

3414

Cause

Communication with mail server failed.

What to Do

Tap **OK** on the touch screen to dismiss the error.

Check that the address and port numbers of the sending mail server (SMTP server) are correct in the Remote UI mail server settings.

➔ [Setting Mail Server](#)

If this does not resolve the error, check the status of the mail server.

Contact the mail server administrator to check the server settings and status.

3415

Cause

Communication with mail server failed.

What to Do

Tap **OK** on the touch screen to dismiss the error.

Check that the address and port numbers of the receiving mail server (POP3 server) are correct in the Remote UI mail server settings.

➔ [Setting Mail Server](#)

If this does not resolve the error, check the status of the mail server.

Contact the mail server administrator to check the server settings and status.

3416

Cause

Communication with mail server failed.

What to Do

Tap **OK** on the touch screen to dismiss the error.

Check that the mail server and device secure connection (SSL) settings match.

Check the secure connection (SSL) settings in **Remote UI**.

➔ [Setting Mail Server](#)

Contact the mail server administrator to configure a secure connection (SSL) to the mail server.

3417

Cause

Communication with mail server failed.

What to Do

Tap **OK** on the touch screen to dismiss the error.

Check that the mail server and device secure connection (SSL) settings match.

Check the secure connection (SSL) settings in **Remote UI**.

➔ [Setting Mail Server](#)

Contact the mail server administrator to configure a secure connection (SSL) to the mail server.

3418

Cause

Communication with mail server failed.

What to Do

Tap **OK** on the touch screen to dismiss the error.

Check that the sending mail server (SMTP server) is correctly configured in the Remote UI mail server settings.

➔ [Setting Mail Server](#)

If this does not resolve the error, check the status of the mail server.

Contact the mail server administrator to check the server settings and status.

3419

Cause

Communication with mail server failed.

What to Do

Tap **OK** on the touch screen to dismiss the error.

Check that the sending account and password are correctly configured in the Remote UI mail server settings.

➔ [Setting Mail Server](#)

If this does not resolve the error, check the status of the mail server.

Contact the mail server administrator to check the server settings and status.

3420

Cause

Communication with mail server failed.

What to Do

Tap **OK** on the touch screen to dismiss the error.

Check that the receiving mail server (POP3 server) is correctly configured in the Remote UI mail server settings.

➔ [Setting Mail Server](#)

If this does not resolve the error, check the status of the mail server.

Contact the mail server administrator to check the server settings and status.

3421

Cause

Communication with mail server failed.

What to Do

Tap **OK** on the touch screen to dismiss the error.

Check that the receiving account and password are correctly configured in the Remote UI mail server settings.

➔ [Setting Mail Server](#)

If this does not resolve the error, check the status of the mail server.

Contact the mail server administrator to check the server settings and status.

3422

Cause

Communication with mail server failed.

What to Do

Tap **OK** on the touch screen to dismiss the error.

Check that the settings on the mail server and the APOP settings on this device match.

Check this device's APOP settings in **Remote UI**.

➔ [Setting Mail Server](#)

Contact the mail server administrator for configuring APOP on the mail server.

3423

Cause

Communication with mail server failed.

What to Do

Tap **OK** on the touch screen to dismiss the error.

Check if the Remote UI mail server settings are correct.

➔ [Setting Mail Server](#)

If this does not resolve the error, check the status of the mail server.

Contact the mail server administrator to check the server settings and status.

3424

Cause

Sending mail failed.

What to Do

Tap **OK** on the touch screen to dismiss the error.

Specify the correct destination mail address and try again.

3448

Cause

IP address is conflicting.

What to Do

Check the network configuration and change the network configuration to prevent a conflict with other network devices.

For details on changing the network configuration, refer to the documentation for your network device.

3451

Cause

Failed to communicate with the monitoring service center.

What to Do

Check the network connection and perform a communication test.

For details on changing the network configuration, refer to the documentation for your network device.

4107

Cause

Possible causes include the following.

- Received print job for Roll 1 while Roll 2 is in use.
- Received print job for Roll 2 while Roll 1 is in use.

What to Do

Tap **OK** on the touch screen to dismiss the error.

Remove the printed matter, and then try again.

4111

Cause

The media type specified is incompatible with this device.

What to Do

Tap **Stop** on the touch screen to stop printing.

Check the media type settings, and then try again.

4112

Cause

Received a print job specifying paper feed from the roll unit, but the roll unit use setting is not set to paper feed.

What to Do

To stop printing, tap **OK** or **Stop** on the touch screen.

Check the roll unit settings, and then try again.

➔ [Switching Roll Unit Modes](#)

Cause

Cannot print borderless for the following reasons.

- Printer driver is not set to **Fit Roll Paper Width**.
- Roll paper is not wide enough, or the paper is out of position.

What to Do

• Stopping printing

Tap **Cancel** on the touch screen.

• Replacing paper

Follow the steps below to replace the printer paper with paper that can be printed borderless.

1. Tap **Replace the paper and print** on the touch screen, then remove the roll paper.

➡ [Removing the Roll from the Printer](#)

➡ [Removing Roll Paper from the Roll Unit](#)

2. Replace the printer paper with paper that can be printed borderless.

➡ [Loading Rolls in the Printer](#)

➡ [Loading Roll Paper in the Roll Unit](#)

• Printing with the loaded paper

Tap **Print with the loaded paper.** on the touch screen.

Paper is printed borderless with the document width set slightly smaller than the paper.

4114

Cause

The paper position is not suitable for borderless printing.

What to Do

Tap **OK** on the touch screen, then reload the paper.

Insert the roll paper firmly until it is against the roll holder flange.

➔ [Loading Rolls on the Roll Holder](#)

Cause

The paper is loaded askew.

What to Do

- **Reloading paper**

Tap **Replace the paper and print** on the touch screen, then reload the paper.

➔ [Loading Rolls in the Printer](#)

➔ [Loading Roll Paper in the Roll Unit](#)

Insert the roll paper firmly until it is against the roll holder flange.

➔ [Loading Rolls on the Roll Holder](#)

- **Printing with the loaded paper**

Tap **Print with the loaded paper.** on the touch screen.

Paper is printed borderless with the document width set slightly smaller than the paper.

- **Stopping printing**

Tap **Cancel** on the touch screen to stop printing.

▶▶▶ Note

- To force the printer to print, set **Detect paper setting mismatch** in the touch screen menu to **Do not detect**.

However, note that this error may affect the printing quality.

Cause

The print job received contains settings not compatible with borderless printing.

What to Do

- **Changing the print job settings**

Follow these steps to change the settings of the print job to enable borderless printing.

1. Tap **Cancel** on the touch screen to stop printing.
2. Check that the paper source is set to Roll Paper in your application.
3. Check that banner printing is not set, and then try again.

See the media information list for media types compatible with borderless printing.

➔ Paper Information List

- **Printing with a border**

Tap **Print with border** on the touch screen.

Printing with a border is now enabled.

▶▶ Note

- To force the printer to print, set **Detect paper setting mismatch** in the touch screen menu to **Do not detect**.

However, note that this error may affect the printing quality.

Cause

Cannot print borderless because the paper is out of position.

What to Do

- **Reloading paper**

Lift up the release lever and reload the roll paper.

➔ [Loading Rolls in the Printer](#)

➔ [Loading Roll Paper in the Roll Unit](#)

- **Printing with the loaded paper**

Tap **Print with the loaded paper.** on the touch screen.

Paper is printed borderless with the document width set slightly smaller than the paper.

- **Stopping printing**

Tap **Cancel** on the touch screen to stop printing.

Cause

The print job received specifies a type or width of paper that is not compatible with borderless printing.

What to Do

- **Changing the print job settings**

Follow these steps to change the settings of the print job to enable borderless printing.

1. Tap **Cancel** on the touch screen to stop printing.
2. Check that the printer driver for the printer has been selected, and then try again.

See the media information list for media types compatible with borderless printing.

➡ Paper Information List

- **Printing with a border**

Tap **Print with border** on the touch screen.

Printing with a border is now enabled.

▶▶ Note

- To force the printer to print, set **Detect paper setting mismatch** in the touch screen menu to **Do not detect**.

However, note that this error may affect the printing quality.

Cause

Cannot print borderless for the following reasons.

- **Fit Roll Paper Width** is not specified in the printer driver.
- Roll paper is not wide enough, or the paper is out of position.

What to Do

- **Stopping printing**

Tap **Cancel** on the touch screen to stop printing.

- **Printing with the loaded paper**

Tap **Print with the loaded paper.** on the touch screen.

Paper is printed borderless with the document width set slightly smaller than the paper.

4122

Cause

The media type in the printer cannot be printed borderless.

What to Do

Tap **Cancel** on the touch screen to stop printing.

▶▶ Note

- See the media information list for media types compatible with borderless printing.
 - ➔ Paper Information List

4801

Cause

A printer error has occurred.

What to Do

Turn off the power, wait a moment, and then turn it back on.

If the error appears again, make a note of the detailed error code (ECxx-xxxx) that appears on the touch screen, and then turn off the power and contact a Canon customer service center.

Detailed error codes

EC01-2F90 EC01-2F95 EC04-2F31 EC04-2F91 EC05-2F92 EC06-2F9A EC06-2F9B EC06-2F9C
EC07-2F19 EC0F-2F96 EC11-2F2A EC12-2F29 EC12-2F2B EC12-2F2C EC13-2F17 EC15-2E23
EC16-2021 EC16-2022 EC16-2027 EC16-202A EC16-2038 EC17-2023 EC17-2024 EC17-2028
EC17-2029 EC17-2039 EC1A-2F45 EC1B-2030 EC1B-2031 EC1B-2032 EC1B-2033 EC1C-2034
EC1C-2035 EC1C-2036 EC1C-2037 EC21-2F51 EC21-2F54 EC21-2F57 EC21-2F59 EC21-2F5B
EC21-2F5D EC21-2F61 EC21-2F67 EC21-2F70 EC21-2F71 EC21-2F72 EC21-2F7D EC22-2F30
EC22-2F47 EC23-260E EC23-2F11 EC23-2F18 EC23-2F32 EC31-2F09 EC31-2F10 EC31-2F1B
EC31-2F1C EC31-2F1D EC31-2F1E EC31-2F1F EC31-2F22 EC31-2F23 EC31-2F94 EC33-2601
EC33-2604 EC33-2F3A EC33-2F3E EC34-2602 EC34-2605 EC34-2F3B EC35-2603 EC35-2606
EC35-2F3C EC51-2F14 EC51-2F15 EC51-2FDD EC51-2FDE EC51-2FDF EC51-3301 EC51-3302
EC51-3303 EC54-290A EC54-290D EC54-2910 EC54-2911 EC54-2912 EC54-2913 EC54-2914
EC55-2F20 EC58-2F12

4803

Cause

A printer error has occurred.

What to Do

Turn off the power, wait a moment, and then turn it back on.

If the error appears again, make a note of the detailed error code (ECxx-xxxx) that appears on the touch screen, and then turn off the power and contact a Canon customer service center.

Detailed error codes

EC51-203C

4804

Cause

A printer error has occurred.

What to Do

Turn off the power, wait a moment, and then turn it back on.

If the error appears again, make a note of the detailed error code (ECxx-xxxx) that appears on the touch screen, and then turn off the power and contact a Canon customer service center.

Detailed error codes

EC17-203D

4805

Cause

A printer error has occurred.

What to Do

Turn off the power, wait a moment, and then turn it back on.

If the error appears again, make a note of the detailed error code (ECxx-xxxx) that appears on the touch screen, and then turn off the power and contact a Canon customer service center.

Detailed error codes

EC1D-2050

4806

Cause

A printer error has occurred.

What to Do

Turn off the power, wait a moment, and then turn it back on.

If the error appears again, make a note of the detailed error code (ECxx-xxxx) that appears on the touch screen, and then turn off the power and contact a Canon customer service center.

Detailed error codes

EC1E-2053

4808

Cause

A printer error has occurred.

What to Do

Turn off the power, wait a moment, and then turn it back on.

If the error appears again, the printer may be damaged. Make a note of the detailed error code (ECxx-xxxx) that appears on the touch screen, and then turn off the power and contact a Canon customer service center.

Detailed error codes

EC64-2FA1

4900

Cause

The printer hard disk is full.

What to Do

tap **Stop** to stop printing, and then take the following action.

- Cancel the print job in the job queue.
 - ➔ [Deleting Print Jobs](#)
- Delete unneeded jobs stored in personal boxes.
 - ➔ [Deleting Saved Jobs](#)

4901

Cause

The printer hard disk has not been formatted.

What to Do

Tap **OK** on the touch screen to begin formatting the hard disk.

When formatting is complete, the data on the hard disc will be erased and the printer will automatically restart.

4903

Cause

The maximum number of jobs have been saved in the box.

What to Do

Take the actions below.

- Cancel the print job in the job queue.
 - ➔ [Deleting Print Jobs](#)
- Delete unneeded jobs stored in personal boxes.
 - ➔ [Deleting Saved Jobs](#)

▶▶ Note

- To stop printing, tap **Stop**.

4905

Cause

A printer error has occurred.

What to Do

Turn off the power, wait a moment, and then turn it back on.

If the error appears again, make a note of the detailed error code (ECxx-xxxx) that appears on the touch screen, and then turn off the power and contact a Canon customer service center.

Detailed error codes

EC51-3304 EC51-3306 EC51-3307 EC51-3308 EC51-3309 EC51-330A

4909

Cause

A printer error has occurred.

What to Do

Turn off the power, wait a moment, and then turn it back on.

If the error appears again, make a note of the detailed error code (ECxx-xxxx) that appears on the touch screen, and then turn off the power and contact a Canon customer service center.

Detailed error codes

EC54-290C

Cause

The width of the roll paper set in **Fit Roll Paper Width** in the printer driver is not the same as the width of the roll paper loaded in the printer.

What to Do

Tap **OK** on the touch screen to go to the next screen.

Check the media type and size that appear and tap **OK**.

- **Stopping printing**

Tap **Cancel** or **Stop** on the touch screen.

- **Replacing the roll paper**

Follow the steps below to replace the paper with roll paper of the width set in the printer driver.

1. Tap **Replace the paper and print**, then remove the roll paper.

- ➔ [Removing the Roll from the Printer](#)

- ➔ [Removing Roll Paper from the Roll Unit](#)

2. Replace the paper with paper of the width set in the printer driver.

- ➔ [Loading Rolls in the Printer](#)

- ➔ [Loading Roll Paper in the Roll Unit](#)

Printing begins.

- **Printing without changes**

Tap **Print with the loaded paper**.

However, note that this error may cause paper jams and affect the printing quality.

▶▶▶ Note

- To change print settings in Windows, select **Fit Roll Paper Width** in the printer driver and set the roll paper width in the dialog box that appears.
- To change print settings in macOS, open the printer driver and select **Fit Roll Paper Width**, and then set the roll paper width in that panel to the width of the paper loaded in the printer.

Cause

The media type specified in the printer driver is not the same as the media type loaded in the printer.

What to Do

Tap **OK** on the touch screen to go to the next screen.

Check the media type and size that appear and tap **OK**.

- **Changing the printer driver print settings**

Follow the steps below to match the media type in the printer driver and the media type specified for the printer.

1. Tap **Cancel** on the touch screen to stop printing.
2. Change the media type in the printer driver settings to the media type loaded in the printer, and then try again.

- **Replacing paper**

Follow the steps below to match the media type in the printer driver and the media type specified for the printer.

1. Tap **Replace the paper and print** on the touch screen to stop printing.
2. Load the paper with the media type set in the printer driver, and then try again.

- ➡ [Loading Rolls in the Printer](#)
- ➡ [Loading Sheets in the Printer](#)

- **Printing without changes**

To continue printing, tap **Print with the loaded paper.** on the touch screen.

However, note that this error may cause paper jams and affect the printing quality.

Cause

Cannot print borderless for one of the following reasons.

- The paper size in the printer cannot be printed borderless.
- The paper is loaded askew.

What to Do

• Replacing paper

Follow the steps below to replace the printer paper with paper that can be printed borderless.

1. Tap **Replace the paper and print** on the touch screen, then remove the roll paper.

- ➔ [Removing the Roll from the Printer](#)
- ➔ [Removing Roll Paper from the Roll Unit](#)

2. Replace the printer paper with paper that can be printed borderless.

- ➔ [Loading Rolls in the Printer](#)
- ➔ [Loading Roll Paper in the Roll Unit](#)

Printing begins.

▶▶▶ Note

See the media information list for media types compatible with borderless printing.

- ➔ Paper Information List

• Reloading paper

Tap **Replace the paper and print** on the touch screen, and then load the paper.

- ➔ [Loading Rolls in the Printer](#)
- ➔ [Loading Roll Paper in the Roll Unit](#)

Insert the roll paper firmly until it is against the roll holder flange.

- ➔ [Loading Rolls on the Roll Holder](#)

• Printing with the loaded paper

Tap **Print with the loaded paper.** on the touch screen.

Paper is printed borderless with the document width set slightly smaller than the paper.

• Stopping printing

Tap **Cancel** on the touch screen to stop printing.

Cause

Cannot cut paper for one of the following reasons.

- Paper that has been cut remains on the output guide.
- There is a foreign object near the output slot that is obstructing the cutter blade.
- The paper is not being used under the recommended usage conditions.
- The paper in use cannot be used with **Automatic cut**.

What to Do

• Paper that has been cut remains on the output guide

Follow the steps below to resume printing.

1. Lift up the release lever and remove the paper.
2. Load the paper.
3. Lower the release lever.
4. If "**There is a job which has not been printed yet. Do you want to print this job?**" appears on the touch screen, tap **Yes**.

Printing will resume, starting from the page on which the error occurred.

➔ [Removing the Roll from the Printer](#)

➔ [Removing Roll Paper from the Roll Unit](#)

• A foreign object near the output slot is obstructing the cutter blade

Follow the steps below to resume printing.

1. Open the top cover and remove any foreign objects.
2. If "**There is a job which has not been printed yet. Do you want to print this job?**" appears on the touch screen, tap **Yes**.

Printing will resume, starting from the page on which the error occurred.

• Paper not being used under the recommended usage conditions

Every paper type has different recommended conditions of use. Use all paper under its recommended usage conditions.

See the media information list for recommended usage conditions.

➔ Paper Information List

• The paper in use cannot be used with Automatic cut

Set the roll paper cutting method to **User cut** and cut the roll paper with a cutting implement such as scissors.

➔ [Specifying the Cutting Method for Rolls](#)

See the media information list for paper types that can be used with **Automatic cut**.

➔ Paper Information List

If this does not apply, there may be a cutter blade malfunction.

Contact your Canon dealer for assistance.

Cause

The Media Take-up Unit cannot roll the paper for one of the following reasons.

- A paper jam has occurred and the roll cannot be rewound.
- The Media Take-up Unit malfunctioned.

What to Do

- **The take-up unit's permitted capacity is exceeded**

Remove paper from the take-up unit.

Tap **OK** on the touch screen to dismiss the error.

▶▶▶ Note

- You can wind the paper until the outer diameter of the wound paper is the same as the outer diameter of the paper core.

- **Paper is jammed or could not be rolled**

Remove the paper from the Media Take-up Unit.

Tap **OK** on the touch screen to dismiss the error.

- **Media Take-up Unit malfunction**

Contact your Canon dealer for assistance.

▶▶▶ Important

- Printing will pause if there is a Media Take-up Unit error. If you do not want to printing to stop, set **Skip errors during take-up** to **ON**. However, note that this error may cause paper jams and affect the printing quality.

Cause

Paper loaded is not suitable for **Color calibration**.

What to Do

Follow the steps below to repeat **Color calibration**.

1. Tap **OK** on the touch screen to dismiss the error.
2. Load paper suitable for **Color calibration**.

See the media information list for suitable paper.

➡ Paper Information List

Make sure the paper in the printer is the same as that in the printer media type settings. The printer will not calibrate properly if the loaded paper and media type settings are not the same.

4925

Cause

The performance of some internal printer sensors may be affected.

What to Do

Tap **OK** on the touch screen to stop **Color calibration**.

Contact your Canon dealer for assistance.

Cause

The supplied paper size is not suitable for **Color calibration**.

What to Do

Tap **OK** on the touch screen to stop **Color calibration**.

Load a paper size suitable for **Color calibration**, and then repeat **Color calibration**.

➔ [Managing Colors](#)

➔ [Performing Color Calibration](#)

Cause

Color calibration may have failed for the following reasons.

- The paper for printing a test pattern is soiled. Otherwise, you have loaded colored paper.
- The printer may be exposed to strong light, such as direct sunlight, which can cause the sensors to malfunction.
- The test pattern was printed too faintly.

What to Do

Tap **OK** on the touch screen to dismiss the error, and then take the following actions.

- Load unused paper suitable for **Color calibration**.
- Make adjustments to ensure that the printer is not exposed to strong light.
- Print a nozzle check pattern to check the print head status.

If the pattern has gaps or horizontal white lines, the print head nozzle is blocked. Clean the print head.

➔ [Checking for Nozzle Clogging](#)

Cause

Paper feed adjustment may have failed for the following reasons.

- The paper for printing a test pattern is soiled. Otherwise, you have loaded colored paper.
- The printer may be exposed to strong light, such as direct sunlight, which can cause the sensors to malfunction.
- The test pattern was printed too faintly.

What to Do

Tap **OK** on the touch screen to dismiss the error, and then take the following actions.

- Load unused paper.
- Make adjustments to ensure that the printer is not exposed to strong light.
- Print a nozzle check pattern to check the print head status.

If the pattern has gaps or horizontal white lines, the print head nozzle is blocked. Clean the print head.

➔ [Checking for Nozzle Clogging](#)

4932

Cause

The print head cannot be calibrated because the printer is loaded with very transparent film-type paper.

What to Do

Tap **OK** on the touch screen to dismiss the error.

We recommend calibrating the print head with a frequently used, non-film paper.

➔ [Automatic Adjustment to Straighten Lines and Align Colors](#)

Cause

The print head nozzle may be blocked.

What to Do

Follow the steps below to repeat **Print Head Alignment**.

1. Tap **OK** on the touch screen to dismiss the error.
2. Print a test pattern to check the nozzles.
 - ➔ [Checking for Nozzle Clogging](#)
3. If the nozzle is blocked, clean the print head.
 - ➔ [Cleaning the Print Head](#)
4. Repeat **Print Head Alignment**.
 - ➔ [Automatic Adjustment to Straighten Lines and Align Colors](#)

Cause

The print head nozzle may be blocked.

What to Do

Follow the steps below to repeat **Print Head Alignment**.

1. Tap **OK** on the touch screen to dismiss the error.
2. Print a test pattern to check the nozzles.
 - ➔ [Checking for Nozzle Clogging](#)
3. If the nozzle is blocked, clean the print head.
 - ➔ [Cleaning the Print Head](#)
4. Repeat **Print Head Alignment**.
 - ➔ [Automatic Adjustment to Straighten Lines and Align Colors](#)

Cause

The print head nozzle may be blocked.

What to Do

Follow the steps below to repeat **Print Head Alignment**.

1. Tap **OK** on the touch screen to dismiss the error.
2. Print a test pattern to check the nozzles.
 - ➔ [Checking for Nozzle Clogging](#)
3. If the nozzle is blocked, clean the print head.
 - ➔ [Cleaning the Print Head](#)
4. Repeat **Print Head Alignment**.
 - ➔ [Automatic Adjustment to Straighten Lines and Align Colors](#)

4950

Cause

WPS (Push button method) connection failed.

What to Do

Follow the instructions on the touch screen to try connecting to the wireless router again.

4952

Cause

Failed to connect to the wireless router.

What to Do

Follow the instructions on the touch screen to try connecting to the wireless router again.

4953

Cause

Failed to acquire IP address.

What to Do

Check the information that appears on the touch screen, and then try connecting again.

4954

Cause

Failed to set up Wi-Fi using Easy wireless connect.

What to Do

Tap **OK** on the touch screen to dismiss the error, and then configure the settings again.

4955

Cause

IPv4/IPv6 settings were changed, but wired LAN and Wi-Fi are disabled.

What to Do

Tap **OK** on the touch screen to dismiss the error, and then enable wired LAN or Wi-Fi.

4956

Cause

Attempted to change LAN settings, but they cannot be changed for the following reasons.

- Printer is operating
- Printer currently being configured using **Remote UI**

What to Do

Tap **OK** on the touch screen to dismiss the error, exit other processes and then configure the settings again.

5200

Cause

A printer error has occurred.

What to Do

Turn off the power and unplug the power cord.

Wait a moment and turn the power back on.

If the error appears again, make a note of the detailed error code (ECxx-xxxx) that appears on the touch screen, and then contact a Canon customer service center.

Detailed error codes

EC21-2F76 EC21-2F77 EC21-2F78

5A60

Cause

A printer error has occurred.

What to Do

Make a note of the detailed error code (ECxx-xxxx) that appears on the touch screen, and then turn off the power and unplug the power cord.

Contact your Canon dealer for assistance.

Detailed error codes

EC33-4020 EC33-4021 EC33-4022 EC33-4023 EC33-4024 EC33-4025 EC33-4026 EC33-4028
EC33-4029 EC33-402A EC33-402C

5B10

Cause

A printer error has occurred.

What to Do

Make a note of the detailed error code (ECxx-xxxx) that appears on the touch screen, and then turn off the power and unplug the power cord.

Contact your Canon dealer for assistance.

Detailed error codes

EC4A-4001

5B16

Cause

A printer error has occurred.

What to Do

Make a note of the detailed error code (ECxx-xxxx) that appears on the touch screen, and then turn off the power and unplug the power cord.

Contact your Canon dealer for assistance.

Detailed error codes

EC22-4001

5B20

Cause

A printer error has occurred.

What to Do

Make a note of the detailed error code (ECxx-xxxx) that appears on the touch screen, and then turn off the power and unplug the power cord.

Contact your Canon dealer for assistance.

Detailed error codes

EC41-4001 EC43-4001 EC44-4001 EC45-4001 EC46-4001 EC47-4001

5B21

Cause

A printer error has occurred.

What to Do

Make a note of the detailed error code (ECxx-xxxx) that appears on the touch screen, and then turn off the power and unplug the power cord.

Contact your Canon dealer for assistance.

Detailed error codes

EC48-4001

5C00

Cause

A printer error has occurred.

What to Do

Make a note of the detailed error code (ECxx-xxxx) that appears on the touch screen, and then turn off the power and unplug the power cord.

Contact your Canon dealer for assistance.

Detailed error codes

EC31-4001

6502

Cause

A printer error has occurred.

What to Do

Turn off the power and unplug the power cord.

Wait a moment and turn the power back on.

If the error appears again, make a note of the detailed error code (ECxx-xxxx) that appears on the touch screen, and then contact a Canon customer service center.

Detailed error codes

EC56-2FE0

6700

Cause

A printer error has occurred.

What to Do

Make a note of the detailed error code (ECxx-xxxx) that appears on the touch screen, and then turn off the power and unplug the power cord.

Contact your Canon dealer for assistance.

Detailed error codes

EC57-404F

6702

Cause

A printer error has occurred.

What to Do

Make a note of the detailed error code (ECxx-xxxx) that appears on the touch screen, and then turn off the power and unplug the power cord.

Contact your Canon dealer for assistance.

Detailed error codes

EC57-4040

6820

Cause

A printer error has occurred.

What to Do

Make a note of the detailed error code (ECxx-xxxx) that appears on the touch screen, and then turn off the power and unplug the power cord.

Contact your Canon dealer for assistance.

Detailed error codes

EC07-4060 EC51-4041 EC51-4042 EC51-4045 EC51-4046 EC51-4047 EC51-404C EC51-404D
EC51-404E EC51-4070 EC51-4071 EC51-4072

6900

Cause

A printer error has occurred.

What to Do

Turn off the power and unplug the power cord.

Wait a moment and turn the power back on.

If the error appears again, make a note of the detailed error code (ECxx-xxxx) that appears on the touch screen, and then contact a Canon customer service center.

Detailed error codes

EC51-3000

6901

Cause

A printer error has occurred.

What to Do

Turn off the power and unplug the power cord.

Wait a moment and turn the power back on.

If the error appears again, make a note of the detailed error code (ECxx-xxxx) that appears on the touch screen, and then contact a Canon customer service center.

Detailed error codes

EC51-3001

6902

Cause

A printer error has occurred.

What to Do

Turn off the power and unplug the power cord.

Wait a moment and turn the power back on.

If the error appears again, make a note of the detailed error code (ECxx-xxxx) that appears on the touch screen, and then contact a Canon customer service center.

Detailed error codes

EC51-3006

6910

Cause

A printer error has occurred.

What to Do

Turn off the power and unplug the power cord.

Wait a moment and turn the power back on.

If the error appears again, make a note of the detailed error code (ECxx-xxxx) that appears on the touch screen, and then contact a Canon customer service center.

Detailed error codes

EC51-3002

6920

Cause

A printer error has occurred.

What to Do

Turn off the power and unplug the power cord.

Wait a moment and turn the power back on.

If the error appears again, make a note of the detailed error code (ECxx-xxxx) that appears on the touch screen, and then contact a Canon customer service center.

Detailed error codes

EC51-3004

6921

Cause

A printer error has occurred.

What to Do

Turn off the power and unplug the power cord.

Wait a moment and turn the power back on.

If the error appears again, make a note of the detailed error code (ECxx-xxxx) that appears on the touch screen, and then contact a Canon customer service center.

Detailed error codes

EC51-3005

6930

Cause

A printer error has occurred.

What to Do

Turn off the power and unplug the power cord.

Wait a moment and turn the power back on.

If the error appears again, make a note of the detailed error code (ECxx-xxxx) that appears on the touch screen, and then contact a Canon customer service center.

Detailed error codes

EC51-3100

6931

Cause

A printer error has occurred.

What to Do

Turn off the power and unplug the power cord.

Wait a moment and turn the power back on.

If the error appears again, make a note of the detailed error code (ECxx-xxxx) that appears on the touch screen, and then contact a Canon customer service center.

Detailed error codes

EC51-3101

6932

Cause

A printer error has occurred.

What to Do

Turn off the power and unplug the power cord.

Wait a moment and turn the power back on.

If the error appears again, make a note of the detailed error code (ECxx-xxxx) that appears on the touch screen, and then contact a Canon customer service center.

Detailed error codes

EC51-3102

6933

Cause

A printer error has occurred.

What to Do

Turn off the power and unplug the power cord.

Wait a moment and turn the power back on.

If the error appears again, make a note of the detailed error code (ECxx-xxxx) that appears on the touch screen, and then contact a Canon customer service center.

Detailed error codes

EC51-3103

6940

Cause

A printer error has occurred.

What to Do

Turn off the power and unplug the power cord.

Wait a moment and turn the power back on.

If the error appears again, make a note of the detailed error code (ECxx-xxxx) that appears on the touch screen, and then contact a Canon customer service center.

Detailed error codes

EC51-3104

6941

Cause

A printer error has occurred.

What to Do

Turn off the power and unplug the power cord.

Wait a moment and turn the power back on.

If the error appears again, make a note of the detailed error code (ECxx-xxxx) that appears on the touch screen, and then contact a Canon customer service center.

Detailed error codes

EC51-3105

6942

Cause

A printer error has occurred.

What to Do

Turn off the power and unplug the power cord.

Wait a moment and turn the power back on.

If the error appears again, make a note of the detailed error code (ECxx-xxxx) that appears on the touch screen, and then contact a Canon customer service center.

Detailed error codes

EC51-3106

6943

Cause

A printer error has occurred.

What to Do

Turn off the power and unplug the power cord.

Wait a moment and turn the power back on.

If the error appears again, make a note of the detailed error code (ECxx-xxxx) that appears on the touch screen, and then contact a Canon customer service center.

Detailed error codes

EC51-3107

6944

Cause

A printer error has occurred.

What to Do

Turn off the power and unplug the power cord.

Wait a moment and turn the power back on.

If the error appears again, make a note of the detailed error code (ECxx-xxxx) that appears on the touch screen, and then contact a Canon customer service center.

Detailed error codes

EC51-3108

6945

Cause

A printer error has occurred.

What to Do

Turn off the power and unplug the power cord.

Wait a moment and turn the power back on.

If the error appears again, make a note of the detailed error code (ECxx-xxxx) that appears on the touch screen, and then contact a Canon customer service center.

Detailed error codes

EC51-3109

6946

Cause

A printer error has occurred.

What to Do

Turn off the power and unplug the power cord.

Wait a moment and turn the power back on.

If the error appears again, make a note of the detailed error code (ECxx-xxxx) that appears on the touch screen, and then contact a Canon customer service center.

Detailed error codes

EC51-3110

7050

Cause

A printer error has occurred.

What to Do

Make a note of the detailed error code (ECxx-xxxx) that appears on the touch screen, and then turn off the power and unplug the power cord.

Contact your Canon dealer for assistance.

Detailed error codes

EC51-5001

7051

Cause

A printer error has occurred.

What to Do

Make a note of the detailed error code (ECxx-xxxx) that appears on the touch screen, and then turn off the power and unplug the power cord.

Contact your Canon dealer for assistance.

Detailed error codes

EC51-5002

7052

Cause

A printer error has occurred.

What to Do

Make a note of the detailed error code (ECxx-xxxx) that appears on the touch screen, and then turn off the power and unplug the power cord.

Contact your Canon dealer for assistance.

Detailed error codes

EC51-5003

8200

Cause

A printer error has occurred.

What to Do

Make a note of the detailed error code (ECxx-xxxx) that appears on the touch screen, and then turn off the power and unplug the power cord.

Contact your Canon dealer for assistance.

Detailed error codes

EC24-4049 EC24-404A EC24-404B

9000

Cause

A printer error has occurred.

What to Do

Make a note of the detailed error code (ECxx-xxxx) that appears on the touch screen, and then turn off the power and unplug the power cord.

Contact your Canon dealer for assistance.

Detailed error codes

EC51-2F07

9110

Cause

A printer error has occurred.

What to Do

Make a note of the detailed error code (ECxx-xxxx) that appears on the touch screen, and then turn off the power and unplug the power cord.

Contact your Canon dealer for assistance.

Detailed error codes

EC52-4038 EC52-4039

B20A

Cause

A printer error has occurred.

What to Do

Make a note of the detailed error code (ECxx-xxxx) that appears on the touch screen, and then turn off the power and unplug the power cord.

Contact your Canon dealer for assistance.

Detailed error codes

EC03-403A EC03-403B

B510

Cause

A printer error has occurred.

What to Do

Make a note of the detailed error code (ECxx-xxxx) that appears on the touch screen, and then turn off the power and unplug the power cord.

Contact your Canon dealer for assistance.

Detailed error codes

EC32-4001

Printer Information

- **Safety**
- **Handling Precautions**
- **Specifications**

Safety

- **Safety Precautions**
- **Regulatory Information**
- **WEEE**

Safety Precautions

Follow the items below to use the printer safely. This may cause unexpected accidents such as fire or electrical shock.

Warning

- **For people who are using a cardiac pacemaker**

This product generates a low-level magnetic field. If you experience discomfort while working around this product, leave the area and consult a doctor.

- **Turn off the power immediately in the following circumstances.**

If you continue to use the printer in the following cases, it may cause fires or electrical shock. Immediately press the power button to turn off the printer, disconnect the power plug from the outlet, and make a request for repairs.

- If any foreign matter (metal fragments, liquids, etc.) gets inside the printer
- If the printer emits smoke, abnormal odors, or abnormal noises
- If the power cord or any of the cables become hot, corroded, bent, frayed, or damaged

- **Follow the items below as there is a risk of fire and electrical shock.**

- Do not set up the product in any location exposed to alcohol, thinner, or other flammable liquids.
- Do not disassemble or modify the product.
- Use the cables that are included with the printer. Do not use the cables included with the printer with other devices.
- Do not use outside of the designated power supply voltage and frequency.
- Insert the power plug securely and completely into the power outlet.
- Never handle the power plug with wet hands.
- Do not damage, modify, pull, bundle, join, or forcefully bend the power cord or any cables.
- Never place a heavy object on the power cord or any cables.
- Do not insert multiple power plugs into the same outlet.
- Do not connect multiple extension cords.
- If there is lightning nearby, disconnect the power plug from the outlet and do not use the product.
- When cleaning, always disconnect the cables and power plug, and do not use highly flammable sprays or liquids such as alcohol or thinner.
- Once per month, disconnect the power plug and power cord from the outlet, and check that dust has not accumulated, and that there are no abnormalities such as heat generation, rust, bending, chafing, or cracking.

Caution

- Never insert your hand into the printer while it is printing.
- Never touch the electrical contacts of the print head by hand immediately after printing.
- The following symbol is displayed around the movable parts of the printer. Take care to avoid touching them with your hand or inserting your finger. Note that this symbol may not appear on your model.



Moving Parts

Keep body parts away from moving parts.

Keep body parts out of the motion path.

• Ink tanks

- Always store consumables out of the reach of small children.
- If a child licks or ingests ink accidentally, wash out their mouth or make them drink 1 or 2 cups of water, and immediately seek medical attention. If ink accidentally gets in your eyes, immediately rinse with water, and immediately seek medical attention.
- If ink gets on your skin, immediately clean it off with soap and water. If irritation persists, immediately seek medical attention.
- If ink becomes adhered to your clothes or anything you are carrying, you might not be able to wash it out.
- Do not leave in a location that gets hot, such as near a fire, near a heater, or in a vehicle. The container may deform, causing the ink to spill, or the ink quality may become degraded.

• Moving the Printer

- Have the following number of people carry the printer. The weight may cause pain such as back pain.

GP-6600S GP-4600S GP-2600S GP-566S GP-546S GP-526S : 6 people or more



Choosing a location

- Never install the printer on an unstable or vibrating surface.
- Do not install the printer in locations that are very humid or dusty, in direct sunlight, outdoors, or close to a heating source.
To avoid the risk of fire or electric shocks, use the printer under the operating environment specified in the [Specifications](#).
- Do not place the printer on a thick rug or carpet.
- Do not place the printer with its back attached to the wall.
- We recommend ensuring ample space for installation.
- Do not install the printer near sources of strong electromagnetic fields, whether equipment that generates such fields or places where such fields occur.

Power Supply

- Ensure that the area around the power outlet is kept clear at all times so you can easily unplug the power cord if necessary.
- Never remove the plug by pulling on the cord.
Pulling the cord may damage the power cord, leading to possible fire or electrical shock.
- Do not use an extension lead/cord.
- A power cord shall be connected to a socket-outlet with earthing connection in order to prevent electric shock.

Working Around the Printer

- Never put your hands or fingers in the printer while it is printing.
- When using and transferring the printer, do not tilt it, stand it on its side, or turn it upside down. There is a risk of the ink spilling.

Print Heads/Ink Tanks/Maintenance Cartridges

- Keep ink tanks out of the reach of children. In case ink is accidentally licked or swallowed, rinse out mouth or give one or two glasses of water to drink. If irritation or discomfort occurs, obtain medical advice immediately.
- In case ink gets in contact with eyes, rinse with water immediately. In case ink gets in contact with skin, wash with soap and water immediately. If irritation to eyes or skin persists, obtain medical advice immediately.
- Never touch the electrical contacts on a print head after printing.
The metal parts may be very hot and could cause burns.
- Do not throw ink tanks and maintenance cartridges into fire.
- Do not attempt to disassemble or modify the print head, ink tanks, and maintenance cartridges.
- Avoid dropping or shaking print head, ink tanks, and maintenance cartridges.

Regulatory Information

Users in the U.S.A.

FCC Notice (U.S.A. Only)

For 120V, 60Hz model

Model Number: K10602/K10603/K10604 (Contains FCC Approved WLAN Module K30387)

Optional parts: Roll Unit RU-63 for GP-6600S(K10604)

Optional parts: Roll Unit RU-43 for GP-4600S(K10603)

Optional parts: Roll Unit RU-23 for GP-2600S(K10602)

This device complies with Part 15 of the FCC Rules. Operation is subject to the following two conditions: (1) This device may not cause harmful interference, and (2) this device must accept any interference received, including interference that may cause undesired operation.

Note: This equipment has been tested and found to comply with the limits for a Class B digital device, pursuant to Part 15 of the FCC Rules. These limits are designed to provide reasonable protection against harmful interference in a residential installation. This equipment generates, uses and can radiate radio frequency energy and, if not installed and used in accordance with the instructions, may cause harmful interference to radio communications.

However, there is no guarantee that interference will not occur in a particular installation. If this equipment does cause harmful interference to radio or television reception, which can be determined by turning the equipment off and on, the user is encouraged to try to correct the interference by one or more of the following measures:

- Reorient or relocate the receiving antenna.
- Increase the separation between the equipment and receiver.
- Connect the equipment into an outlet on a circuit different from that to which the receiver is connected.
- Consult the dealer or an experienced radio/TV technician for help.

Use of a shielded cable is required to comply with Class B limits in Subpart B of Part 15 of the FCC Rules.

Do not make any changes or modifications to the equipment unless otherwise specified in the manual. If such changes or modifications should be made, you could be required to stop operation of the equipment.

Changes or modifications not expressly approved by the party responsible for compliance could void the user's authority to operate equipment.

This transmitter must not be co-located or operating in conjunction with any other antenna or transmitter.

This equipment complies with FCC radiation exposure limits set forth for an uncontrolled environment and meets the FCC radio frequency (RF) Exposure Guidelines as this equipment has very low levels of RF energy.

But it is desirable that it should be installed and operated keeping the radiator at least 20cm or more away from person's body.

Canon U.S.A., Inc.

One Canon Park

Melville, New York 11747

1-800-652-2666

Interference

Do not use the printer around medical equipment or other electronic devices. Signals from the printer may interfere with the correct operation of these devices.

WEEE

Only for the United Kingdom



These symbols indicate that this product is not to be disposed of with your household waste, according to the UK Waste Electrical and Electronic Equipment Regulations and the UK Batteries and Accumulators Regulations. If a chemical symbol is printed beneath the symbol shown above, in accordance with the UK Batteries and Accumulators Regulations, this indicates that a heavy metal (Hg = Mercury, Cd = Cadmium, Pb = Lead) is present in this battery or accumulator at a concentration above an applicable threshold specified in the UK Batteries and Accumulators Regulations. This product should be handed over to a designated collection point, e.g., on an authorized one-for-one basis when you buy a new similar product or to an authorized collection site for recycling waste electrical and electronic equipment (EEE) and batteries and accumulators. Improper handling of this type of waste could have a possible impact on the environment and human health due to potentially hazardous substances that are generally associated with EEE. Your cooperation in the correct disposal of this product will contribute to the effective usage of natural resources. For more information about the recycling of this product, please contact your local city office, waste authority, approved scheme or your household waste disposal service or visit www.canon-europe.com/sustainability/approach/.

Only for European Union and EEA (Norway, Iceland and Liechtenstein)



These symbols indicate that this product is not to be disposed of with your household waste, according to the WEEE Directive (2012/19/EU), the Battery Directive (2006/66/EC) and/or national legislation implementing those Directives. If a chemical symbol is printed beneath the symbol shown above, in accordance with the Battery Directive, this indicates that a heavy metal (Hg = Mercury, Cd = Cadmium, Pb = Lead) is present in this battery or accumulator at a concentration above an applicable threshold specified in the Battery Directive. This product should be handed over to a designated collection point, e.g., on an authorized one-for-one basis when you buy a new similar product or to an authorized collection site for recycling waste electrical and electronic equipment (EEE) and batteries and accumulators. Improper handling of this type of waste could have a possible impact on the environment and human health due to potentially hazardous substances that are generally associated with EEE. Your cooperation in the correct disposal of this product will contribute to the effective usage of natural resources. For more information about the recycling of this product, please contact your local city office, waste authority, approved scheme or your household waste disposal service or visit www.canon-europe.com/weee, or www.canon-europe.com/battery.

Nur für Europäische Union und EWR (Norwegen, Island und Liechtenstein)



Diese Symbole weisen darauf hin, dass dieses Produkt gemäß WEEE-Richtlinie (2012/19/EU; Richtlinie über Elektro- und Elektronik-Altgeräte), Batterien-Richtlinie (2006/66/EG) und nationalen Gesetzen zur Umsetzung dieser Richtlinien nicht über den Hausmüll entsorgt werden darf. Falls sich unter dem oben abgebildeten Symbol ein chemisches Symbol befindet, bedeutet dies gemäß der Batterien-Richtlinie, dass in dieser Batterie oder diesem Akkumulator ein Schwermetall (Hg = Quecksilber, Cd = Cadmium, Pb = Blei) in einer Konzentration vorhanden ist, die über einem in der Batterien-Richtlinie angegebenen Grenzwert liegt. Dieses Produkt muss bei einer dafür vorgesehenen Sammelstelle abgegeben werden. Dies kann z. B. durch Rückgabe beim Kauf eines neuen ähnlichen Produkts oder durch Abgabe bei einer autorisierten Sammelstelle für die Wiederaufbereitung von Elektro- und Elektronik-Altgeräten sowie Batterien und Akkumulatoren geschehen. Der unsachgemäße Umgang mit Altgeräten kann aufgrund potenziell gefährlicher Stoffe, die generell mit Elektro- und Elektronik-Altgeräten in Verbindung stehen, negative Auswirkungen auf die Umwelt und die menschliche Gesundheit haben. Durch Ihre Mitarbeit bei der umweltgerechten Entsorgung dieses Produkts tragen Sie zu einer effektiven Nutzung natürlicher Ressourcen bei. Um weitere Informationen über die Wiederverwertung dieses Produkts zu erhalten, wenden Sie sich an Ihre Stadtverwaltung, den öffentlich-rechtlichen Entsorgungsträger, eine autorisierte Stelle für die Entsorgung von Elektro- und Elektronik-Altgeräten oder Ihr örtliches Entsorgungsunternehmen oder besuchen Sie www.canon-europe.com/weee, oder www.canon-europe.com/battery.

Zusatzinformationen für Deutschland:

Dieses Produkt kann durch Rückgabe an den Händler unter den in der Verordnung des Elektro- und Elektronikgerätegesetzes beschriebenen Bedingungen abgegeben werden.

Als Endbenutzer und Besitzer von Elektro- oder Elektronikgeräten sind Sie verpflichtet:

- diese einer vom unsortierten Siedlungsabfall getrennten Erfassung zuzuführen,
- Altbatterien und Altkumulatoren, die nicht vom Altgerät umschlossen sind, sowie Lampen, die zerstörungsfrei aus dem Altgerät entnommen werden können, vor der Abgabe an einer Erfassungsstelle vom Altgerät zerstörungsfrei zu trennen,
- personenbezogener Daten auf den Altgeräten vor der Entsorgung zu löschen. Die Bedeutung von dem Symbol der durchgestrichenen Abfalltonne auf Rädern finden Sie oben in dieser Beschreibung.

Die Vertreiber von Elektro- oder Elektronikgeräten haben die Pflicht zur unentgeltlichen Rücknahme von Altgeräten. Die Vertreiber haben die Endnutzer über die von ihnen geschaffenen Möglichkeiten der Rückgabe von Altgeräten zu informieren.

Union Européenne, Norvège, Islande et Liechtenstein uniquement.



Ces symboles indiquent que ce produit ne doit pas être mis au rebut avec les ordures ménagères, comme le spécifient la Directive européenne DEEE (2012/19/UE), la Directive européenne relative à l'élimination

des piles et des accumulateurs usagés (2006/66/CE) et les lois en vigueur dans votre pays appliquant ces directives. Si un symbole de toxicité chimique est imprimé sous le symbole illustré ci-dessus conformément à la Directive relative aux piles et aux accumulateurs, il indique la présence d'un métal lourd (Hg = mercure, Cd = cadmium, Pb = plomb) dans la pile ou l'accumulateur à une concentration supérieure au seuil applicable spécifié par la Directive. Ce produit doit être confié au distributeur à chaque fois que vous achetez un produit neuf similaire, ou à un point de collecte mis en place par les collectivités locales pour le recyclage des Déchets des Équipements Électriques et Électroniques (DEEE). Le traitement inapproprié de ce type de déchet risque d'avoir des répercussions sur l'environnement et la santé humaine, du fait de la présence de substances potentiellement dangereuses généralement associées aux équipements électriques et électroniques. Votre entière coopération dans le cadre de la mise au rebut correcte de ce produit favorisera une meilleure utilisation des ressources naturelles. Pour plus d'informations sur le recyclage de ce produit, contactez vos services municipaux, votre éco-organisme ou les autorités locales compétentes, ou consultez le site www.canon-europe.com/weee, ou www.canon-europe.com/battery.

Uitsluitend bestemd voor de Europese Unie en EER (Noorwegen, IJsland en Liechtenstein)



Met deze symbolen wordt aangegeven dat dit product in overeenstemming met de AEEA-richtlijn (2012/19/EU), de richtlijn 2006/66/EG betreffende batterijen en accu's en/of de plaatselijk geldende wetgeving waarin deze richtlijnen zijn geïmplementeerd, niet bij het normale huisvuil mag worden weggegooid. Indien onder het hierboven getoonde symbool een chemisch symbool gedrukt staat, geeft dit in overeenstemming met de richtlijn betreffende batterijen en accu's aan dat deze batterij of accu een zwaar metaal bevat (Hg = kwik, Cd = cadmium, Pb = lood) waarvan de concentratie de toepasselijke drempelwaarde in overeenstemming met de genoemde richtlijn overschrijdt. Dit product dient te worden ingeleverd bij een hiervoor aangewezen inzamelpunt, bijv. door dit in te leveren bij een hiertoe erkend verkooppunt bij aankoop van een gelijksoortig product, of bij een officiële inzameldienst voor de recycling van elektrische en elektronische apparatuur (EEA) en batterijen en accu's. Door de potentieel gevaarlijke stoffen die gewoonlijk gepaard gaan met EEA, kan onjuiste verwerking van dit type afval mogelijk nadelige gevolgen hebben voor het milieu en de menselijke gezondheid. Uw medewerking bij het op juiste wijze weggooien van dit product draagt bij tot effectief gebruik van natuurlijke hulpbronnen. Voor verdere informatie over recycling van dit product kunt u contact opnemen met uw plaatselijke gemeente, afvaldienst, officiële dienst voor klein chemisch afval of afvalstortplaats, of kunt u terecht op www.canon-europe.com/weee, of www.canon-europe.com/battery.

Sólo para la Unión Europea y el Área Económica Europea (Noruega, Islandia y Liechtenstein)



Estos iconos indican que este producto no debe desecharse con los residuos domésticos de acuerdo con la Directiva sobre RAEE (2012/19/UE) y la Directiva sobre Pilas y Acumuladores (2006/66/CE) y/o la legislación nacional. Si aparece un símbolo químico bajo este icono, de acuerdo con la Directiva sobre Pilas y Acumuladores, significa que la pila o el acumulador contiene metales pesados (Hg = Mercurio, Cd = Cadmio, Pb = Plomo) en una concentración superior al límite especificado en dicha directiva. Este producto deberá entregarse en un punto de recogida designado, por ejemplo, entregándolo en el lugar de venta al adquirir un producto nuevo similar o en un centro autorizado para la recogida de residuos de aparatos eléctricos y electrónicos (RAEE), baterías y acumuladores. La gestión incorrecta de este tipo de residuos puede afectar al medio ambiente y a la salud humana debido a las sustancias potencialmente nocivas que suelen contener estos aparatos. Su cooperación en la correcta eliminación de este producto contribuirá al correcto aprovechamiento de los recursos naturales. Los usuarios tienen derecho a devolver pilas, acumuladores o baterías usados sin coste alguno. El precio de venta de pilas, acumuladores y baterías incluye el coste de la gestión medioambiental de su desecho, y no es necesario mostrar la cuantía de dicho coste en la información y la factura suministradas a los usuarios finales. Si desea más información sobre el reciclado de este producto, póngase en contacto con su municipio, el servicio o el organismo encargado de la gestión de residuos domésticos o visite www.canon-europe.com/weee, o www.canon-europe.com/battery.

Només per a la Unió Europea i a l'Espai Econòmic Europeu (Noruega, Islàndia i Liechtenstein)



Aquests símbols indiquen que aquest producte no s'ha de llençar amb les escombraries de la llar, d'acord amb la RAEE (2012/19/UE), la Directiva relativa a piles i acumuladors (2006/66/CE) i la legislació nacional que implementi aquestes directives. Si al costat d'aquest símbol hi apareix imprès un símbol químic, segons especifica la Directiva relativa a piles i acumuladors, significa que la bateria o l'acumulador conté un metall pesant (Hg = mercuri, Cd = cadmi, Pb = plom) en una concentració superior al límit aplicable especificat en la Directiva. Aquest producte s'hauria de lliurar en un dels punts de recollida designats, com per exemple, intercanviant un per un en comprar un producte similar o lliurant-lo en un lloc de recollida autoritzat per al reciclatge de residus d'aparells elèctrics i electrònics (RAEE) i piles i acumuladors. La manipulació inadequada d'aquest tipus de residus podria tenir un impacte negatiu en l'entorn i en la salut humana, a causa de les substàncies potencialment perilloses que normalment estan associades a l'RAEE. La vostra cooperació a l'hora de rebutjar correctament aquest producte contribuirà a la utilització efectiva dels recursos naturals. Els usuaris tenen dret a retornar les bateries o els acumuladors usats sense cap càrrec. El preu de venda de les bateries i els acumuladors inclou el cost de la gestió ambiental dels residus i no es necessari mostrar l'import d'aquest cost en aquest fulllet o en la factura que es lliuri a l'usuari final. Per a més informació sobre el reciclatge d'aquest producte, contacteu amb l'oficina municipal, les autoritats encarregades dels residus, el pla de residus homologat o el servei de recollida d'escombraries domèstiques de la vostra localitat o visiteu www.canon-europe.com/weee, o www.canon-europe.com/battery.

Solo per Unione Europea e SEE (Norvegia, Islanda e Liechtenstein)



Questi simboli indicano che il prodotto non può essere smaltito con i rifiuti domestici, ai sensi della Direttiva RAEE (2012/19/UE), della Direttiva sulle Batterie (2006/66/CE) e/o delle leggi nazionali che attuano tali Direttive. Se sotto il simbolo indicato sopra è riportato un simbolo chimico, in osservanza della Direttiva sulle batterie, tale simbolo indica la presenza di un metallo pesante (Hg = Mercurio, Cd = Cadmio, Pb = Piombo) nella batteria o nell'accumulatore con un livello di concentrazione superiore a una soglia applicabile specificata nella Direttiva sulle batterie. Il prodotto deve essere conferito a un punto di raccolta designato, ad esempio il rivenditore in caso di acquisto di un nuovo prodotto simile oppure un centro di raccolta autorizzato per il riciclaggio di rifiuti di apparecchiature elettriche ed elettroniche (RAEE) nonché di batterie e accumulatori. Un trattamento improprio di questo tipo di rifiuti può avere conseguenze negative sull'ambiente e sulla salute umana a causa delle sostanze potenzialmente nocive solitamente contenute in tali rifiuti. La collaborazione dell'utente per il corretto smaltimento di questo prodotto contribuirà a un utilizzo efficace delle risorse naturali ed eviterà di incorrere in sanzioni amministrative ai sensi dell'art. 255 e successivi del Decreto Legislativo n. 152/06. Per ulteriori informazioni sul riciclaggio di questo prodotto, contattare le autorità locali, l'ente responsabile della raccolta dei rifiuti, un rivenditore autorizzato o il servizio di raccolta dei rifiuti domestici, oppure visitare il sito www.canon-europe.com/weee, o www.canon-europe.com/battery.

Apenas para a União Europeia e AEE (Noruega, Islândia e Liechtenstein)



Estes símbolos indicam que este produto não deve ser eliminado juntamente com o seu lixo doméstico, segundo a Diretiva REEE de 2012/19/UE, a Diretiva de Baterias (2006/66/CE) e/ou a sua legislação nacional que transponha estas Diretivas. Se houver um símbolo químico impresso como mostrado abaixo, de acordo com a Diretiva de Baterias, isto indica que um metal pesado (Hg = Mercúrio, Cd = Cádmiio, Pb = Chumbo) está presente nesta pilha ou acumulador, numa concentração acima de um limite aplicável especificado na Diretiva. Este produto deve ser entregue num ponto de recolha designado, por exemplo num local autorizado de troca quando compra um equipamento novo idêntico, ou num local de recolha autorizado para reciclar equipamento elétrico e eletrónico (EEE) em fim de vida, bem como pilhas e baterias. O tratamento inadequado deste tipo de resíduos pode ter um impacto negativo no ambiente e na saúde humana, devido a substâncias potencialmente perigosas que estão associadas com equipamentos do tipo EEE. A sua cooperação no tratamento correto deste produto irá contribuir para a utilização mais eficaz dos recursos naturais. Para obter mais informações acerca de como reciclar este produto, por favor contacte as suas autoridades locais responsáveis pela matéria, serviço de recolha aprovado para pilhas e baterias ou serviço de recolha de resíduos sólidos domésticos da sua municipalidade, ou visite www.canon-europe.com/weee, ou www.canon-europe.com/battery.

Γælder kun i Europæiske Union og EØS (Norge, Island og Liechtenstein)



Disse symboler betyder, at produktet ikke må bortskaffes sammen med dagrenovation i henhold til WEEE-direktivet (2012/19/EU), batteridirektivet (2006/66/EF) og/eller den lokale lovgivning, som disse direktiver er gennemført i. Hvis der i overensstemmelse med batteridirektivet er trykt et kemisk symbol under det symbol, der er vist ovenfor, betyder det, at batteriet eller akkumulatoren indeholder tungmetaller (Hg = kviksølv, Cd = cadmium, Pb = bly) i en koncentration, som ligger over de grænseværdier, der er beskrevet i batteridirektivet. Produktet skal afleveres på et godkendt indsamlingssted, f.eks. i overensstemmelse med en godkendt én-til-én-procedure, når du indkøber et nyt tilsvarende produkt, eller på et godkendt indsamlingssted for elektronikaffald samt for batterier og akkumulatore. Forkert håndtering af denne type affald kan medføre negative konsekvenser for miljøet og menneskers helbred på grund af de potentielt sundhedsskadelige stoffer, der generelt kan forefindes i elektrisk og elektronisk udstyr. Når du foretager korrekt bortskaffelse af produktet, bidrager du til effektiv brug af naturressourcerne. Kontakt din kommune, den lokale affaldsmyndighed, det lokale affaldsanlæg, eller besøg www.canon-europe.com/weee, eller www.canon-europe.com/battery for at få flere oplysninger om genbrug af dette produkt.

Μόνο για την Ευρωπαϊκή Ένωση και τον ΕΟΧ (Νορβηγία, Ισλανδία και Λιχτενστάιν)



Αυτά τα σύμβολα υποδεικνύουν ότι αυτό το προϊόν δεν πρέπει να απορρίπτεται μαζί με τα οικιακά απορρίμματα, σύμφωνα με την Οδηγία για τα Απόβλητα Ηλεκτρικού και Ηλεκτρονικού Εξοπλισμού (ΑΗΗΕ) (2012/19/ΕΕ), την Οδηγία για τις Ηλεκτρικές Στήλες (2006/66/ΕΚ) ή/και την εθνική νομοθεσία που εφαρμόζει τις Οδηγίες εκείνες. Εάν κάποιο χημικό σύμβολο είναι τυπωμένο κάτω από το σύμβολο που φαίνεται παραπάνω, σύμφωνα με την Οδηγία για τις Ηλεκτρικές Στήλες, υποδηλώνει ότι κάποιο βαρύ μέταλλο (Hg = Υδράργυρος, Cd = Κάδμιο, Pb = Μόλυβδος) υπάρχει στην μπαταρία ή τον συσσωρευτή σε συγκέντρωση μεγαλύτερη από το ισχύον επίπεδο που καθορίζεται στην Οδηγία για τις Ηλεκτρικές Στήλες. Αυτό το προϊόν πρέπει να παραδίδεται σε καθορισμένο σημείο συλλογής, π.χ. σε μια εξουσιοδοτημένη βάση ανταλλαγής όταν αγοράζετε ένα νέο παρόμοιο προϊόν ή σε μια εξουσιοδοτημένη θέση συλλογής για την ανακύκλωση των αποβλήτων ηλεκτρικού και ηλεκτρονικού εξοπλισμού (ΗΗΕ) και των ηλεκτρικών στηλών και συσσωρευτών. Ο ακατάλληλος χειρισμός αυτού του τύπου αποβλήτων μπορεί να έχει αρνητικό αντίκτυπο στο περιβάλλον και την υγεία του ανθρώπου, λόγω δυνητικά επικίνδυνων ουσιών που γενικά συνδέονται με τον ΗΗΕ. Η συνεργασία σας για τη σωστή απόρριψη αυτού του προϊόντος θα συμβάλει στην αποτελεσματική χρήση των φυσικών πόρων. Για περισσότερες πληροφορίες σχετικά με ανακύκλωση αυτού του προϊόντος, επικοινωνήστε με το τοπικό γραφείο της πόλης σας, την υπηρεσία απορριμμάτων, το εγκεκριμένο σχήμα ή την υπηρεσία απόρριψης οικιακών αποβλήτων ή επισκεφθείτε τη διεύθυνση www.canon-europe.com/weee ή www.canon-europe.com/battery.

Gjelder kun den europeiske union og EØS (Norge, Island og Liechtenstein)



Disse symbolene indikerer at dette produktet ikke skal kastes sammen med husholdningsavfall, i henhold til WEEE-direktivet (2012/19/EU), batteridirektivet (2006/66/EF) og/eller nasjonal lov som har implementert disse direktivene. Hvis et kjemisk symbol vises under symbolet vist ovenfor, i samsvar med batteridirektivet, indikerer dette at et tungmetall (Hg = kvikksølv, Cd = kadmium, Pb = bly) finnes i batteriet eller akkumulatoren i en konsentrasjon over en gjeldende øvre grense som er spesifisert i batteridirektivet. Produktet må leveres til et dertil egnet innsamlingspunkt, det vil si på en autorisert en-til-en-basis når en kjøper et nytt lignende produkt, eller til et autorisert innsamlingssted for resirkulering av avfall fra elektrisk og elektronisk utstyr (EE-utstyr) og batterier og akkumulatører. Feil håndtering av denne typen avfall kan være miljø- og helseskadelig på grunn av potensielt skadelige stoffer som ofte brukes i EE-utstyr. Din innsats for korrekt avhending av produktet vil bidra til effektiv bruk av naturressurser. Du kan få mer informasjon om resirkulering av dette produktet ved å kontakte lokale myndigheter, avfallsadministrasjonen, et godkjent program eller husholdningens renovasjonsselskap, eller gå til www.canon-europe.com/weee, eller www.canon-europe.com/battery.

Vain Euroopan unionin sekä ETA:n (Norja, Islanti ja Liechtenstein) alueelle.



Nämä tunnukset osoittavat, että sähkö- ja elektroniikkalaiteromua koskeva direktiivi (SER-direktiivi, 2012/19/EU), paristoista ja akuista annettu direktiivi (2006/66/EY) sekä kansallinen lainsäädäntö kieltävät tuotteen hävittämisen talousjätteen mukana. Jos yllä olevan symbolin alapuolelle on paristodirektiivin mukaisesti painettu kemiallisen aineen tunnus, kyseinen paristo tai akku sisältää raskasmetalleja (Hg = elohopea, Cd = kadmium, Pb = lyijy) enemmän kuin paristodirektiivin salliman määrän. Tuote on vietävä asianmukaiseen keräyspisteeseen, esimerkiksi kodinkoneliikkeeseen uutta vastaavaa tuotetta ostettaessa tai viralliseen sähkö- ja elektroniikkalaiteromun tai paristojen ja akkujen keräyspisteeseen. Sähkö- ja elektroniikkalaiteromun virheellinen käsittely voi vahingoittaa ympäristöä ja ihmisten terveyttä, koska laitteet saattavat sisältää ympäristölle ja terveydelle haitallisia aineita. Tuotteen asianmukainen hävittäminen säästää myös luonnonvaroja. Jos haluat lisätietoja tämän tuotteen kierrätyksestä, ota yhteys kunnan jätehuoltoviranomaisiin tai käyttämäsi jätehuoltoyhtiöön tai käy osoitteessa www.canon-europe.com/weee, tai www.canon-europe.com/battery.

Endast för Europeiska unionen och EES (Norge, Island och Liechtenstein)



De här symbolerna visar att produkten inte får sorteras och slängas som hushållsavfall enligt WEEE-direktivet (2012/19/EU), batteridirektivet (2006/66/EG) och/eller nationell lagstiftning som implementerar dessa direktiv. Om en kemisk symbol förekommer under ovanstående symbol innebär detta enligt Batteridirektivet att en tungmetall (Hg = Kvicksilver, Cd = Kadmium, Pb = Bly) förekommer i batteriet eller ackumulatorn med en koncentration som överstiger tillämplig gräns som anges i Batteridirektivet. Produkten ska lämnas in på en avsedd insamlingsplats, t.ex. på en återvinningsstation auktoriserad att hantera elektrisk och elektronisk utrustning (EE-utrustning) samt batterier och ackumulatörer eller hos handlare som är auktoriserade att byta in varor då nya, motsvarande köps (en mot en). Olämplig hantering av avfall av den här typen kan ha negativ inverkan på miljön och människors hälsa på grund av de potentiellt farliga ämnen som kan återfinnas i elektrisk och elektronisk utrustning. Din medverkan till en korrekt avfallshantering av produkten bidrar till effektiv användning av naturresurserna. Om du vill ha mer information om var du kan lämna in den här produkten, kontakta ditt lokala kommunkontor, berörd myndighet eller företag för avfallshantering eller se www.canon-europe.com/weee, eller www.canon-europe.com/battery.

Pouze Evropská unie a EHP (Norsko, Island a Lichtenštejnsko)



Tento symbol znamená, že podle směrnice OEEZ (2012/19/EU), směrnice o bateriích (2006/66/ES) a/ nebo podle vnitrostátních právních prováděcích předpisů k těmto směrnici nemá být tento výrobek likvidován s odpadem z domácností. Je-li v souladu s požadavky směrnice o bateriích vytištěna pod výše uvedeným symbolem chemická značka, udává, že tato baterie nebo akumulátor obsahuje těžké kovy (Hg = rtuť, Cd = kadmium, Pb = olovo) v koncentraci vyšší, než je příslušná hodnota předepsaná směrnicí. Tento výrobek má být vrácen do určeného sběrného místa, např. v rámci autorizovaného systému odběru jednoho výrobku za jeden nově prodaný podobný výrobek, nebo do autorizovaného sběrného místa pro recyklaci odpadních elektrických a elektronických zařízení (OEEZ), baterií a akumulátorů. Nevhodné nakládání s tímto druhem odpadu by mohlo mít negativní dopad na životní prostředí a lidské zdraví, protože elektrická a elektronická zařízení zpravidla obsahují potenciálně nebezpečné látky. Vaše spolupráce na správné likvidaci tohoto výrobku napomůže efektivnímu využívání přírodních zdrojů. Chcete-li získat podrobné informace týkající se recyklace tohoto výrobku, obraťte se prosím na místní úřad, orgán pro nakládání s odpady, schválený systém nakládání s odpady či společnost zajišťující likvidaci domovního odpadu, nebo navštivte webové stránky www.canon-europe.com/weee nebo www.canon-europe.com/battery.

Csak az Európai Unió és az EGT (Norvégia, Izland és Liechtenstein) országáiban



Ezek a szimbólumok azt jelzik, hogy a termék hulladékkezelése a háztartási hulladéktól különválasztva, az elektromos és elektronikus berendezések hulladékairól (WEEE) szóló (2012/19/EU) irányelvnek és az elemekről és akkumulátorokról, valamint a hulladék elemekről és akkumulátorokról szóló (2006/66/EK)

irányelvnek megfelelően és/vagy ezen irányelveknek megfelelő helyi előírások szerint történik. Amennyiben a fent feltüntetett szimbólum alatt egy vegyjel is szerepel, az elemekről és akkumulátorokról szóló irányelvben foglaltak értelmében ez azt jelzi, hogy az elem vagy az akkumulátor az irányelvben meghatározott határértéknél nagyobb mennyiségben tartalmaz nehézfémeket (Hg = higany, Cd = kadmium, Pb = ólom). E terméket az arra kijelölt gyűjtőhelyre kell juttatni – pl. hasonló termék vásárlásakor a régi becserélésére vonatkozó hivatalos program keretében, vagy az elektromos és elektronikus berendezések (EEE) hulladékainak gyűjtésére, valamint a hulladék elemek és hulladék akkumulátorok gyűjtésére kijelölt hivatalos gyűjtőhelyre. Az ilyen jellegű hulladékok nem előírászerű kezelése az elektromos és elektronikus berendezésekhez (EEE) általánosan kapcsolható potenciálisan veszélyes anyagok révén hatással lehet a környezetre és az egészségre. E termék megfelelő leselejtezésével Ön is hozzájárul a természeti források hatékony használatához. A termék újrahasznosítását illetően informálódjon a helyi polgármesteri hivatalnál, a helyi közterület-fenntartó vállalatnál, a hivatalos hulladéklerakó telephelyen vagy a háztartási hulladék begyűjtését végző szolgáltatónál, illetve látogasson el a www.canon-europe.com/weee, vagy www.canon-europe.com/battery internetes oldalra.

Tylko dla krajów Unii Europejskiej oraz EOG (Norwegia, Islandia i Liechtenstein)



Te symbole oznaczają, że produktu nie należy wyrzucać razem z odpadami gospodarstwa domowego, zgodnie z dyrektywą WEEE w sprawie zużytego sprzętu elektrycznego i elektronicznego (2012/19/UE) lub dyrektywą w sprawie baterii (2006/66/WE) bądź przepisami krajowymi wdrażającymi te dyrektywy. Jeśli pod powyższym symbolem znajduje się symbol chemiczny, zgodnie z dyrektywą w sprawie baterii oznacza to, że bateria lub akumulator zawiera metal ciężki (Hg = rtęć, Cd = kadm, Pb = ołów) w stężeniu przekraczającym odpowiedni poziom określony w dyrektywie w sprawie baterii. Użytkownicy baterii i akumulatorów mają obowiązek korzystać z dostępnego programu zwrotu, recyklingu i utylizacji baterii oraz akumulatorów. Niewłaściwe postępowanie z tego typu odpadami może mieć wpływ na środowisko i zdrowie ludzi ze względu na substancje potencjalnie niebezpieczne, związane ze użytym sprzętem elektrycznym i elektronicznym. Państwa współpraca w zakresie właściwej utylizacji tego produktu przyczyni się do efektywnego wykorzystania zasobów naturalnych. W celu uzyskania informacji o sposobie recyklingu tego produktu prosimy o kontakt z właściwym urzędem miejskim lub zakładem gospodarki komunalnej bądź zapraszamy na stronę www.canon-europe.com/weee, lub www.canon-europe.com/battery.

Platí len pre štáty Európskej únie a EHP (Nórsko, Island a Lichtenštajnsko)



Tieto symboly označujú, že podľa Smernice o odpade z elektrických a elektronických zariadení (OEEZ) 2012/19/EÚ, Smernice o batériách (2006/66/ES) a podľa platnej legislatívy Slovenskej republiky sa tento produkt nesmie likvidovať spolu s komunálnym odpadom. Ak je chemická značka vytlačená pod vyššie

uvedeným symbolom, znamená to, že táto batéria alebo akumulátor obsahuje ťažký kov (Hg = ortuť, Cd = kadmium, Pb = olovo) v koncentrácii vyššej, ako je príslušná povolená hodnota stanovená v Smernici o batériách. Produkt je potrebné odovzdať do určenej zberne, napr. prostredníctvom výmeny za kúpu nového podobného produktu, alebo na autorizované zberné miesto, ktoré spracúva odpad z elektrických a elektronických zariadení (EEZ), batérií a akumulátorov. Nesprávna manipulácia s takýmto typom odpadu môže mať negatívny vplyv na životné prostredie a ľudské zdravie, pretože elektrické a elektronické zariadenia obsahujú potenciálne nebezpečné látky. Spoluprácou na správnej likvidácii tohto produktu prispějete k účinnému využívaniu prírodných zdrojov. Ďalšie informácie o recyklácii tohto produktu získate od miestneho úradu, úradu životného prostredia, zo schváleného plánu OEEZ alebo od spoločnosti, ktorá zaisťuje likvidáciu komunálneho odpadu. Viac informácií nájdete aj na webovej stránke: www.canon-europe.com/weee, alebo www.canon-europe.com/battery.

Üksnes Euroopa Liit ja EMP (Norra, Island ja Liechtenstein)



Antud sümbolid viitavad sellele, et vastavalt elektri- ja elektroonikaseadmete jäätmeid käsitlevale direktiivile (2012/19/EL), patareisid ja akusid ning patarei- ja akujäätmeid käsitlevale direktiivile (2006/66/EÜ) ja/või nimetatud direktiive rakendavatele riiklikele õigusaktidele ei või seda toodet koos olmejäätmetega ära visata. Kui keemiline sümbol on trükitud eespool toodud sümboli alla, siis tähendab see, et antud patareis või akus leiduva raskemetalli (Hg = elavhõbe, Cd = kaadmium, Pb = plii) kontsentratsioonitase on kõrgem kui patareisid ja akusid ning patarei- ja akujäätmeid käsitlevas direktiivis sätestatud piirmäär. Antud tootest tekkinud jäätmed tuleb anda vastavasse kogumispunkti, nt müügipunkti, mis on volitatud üks ühe vastu vahetama, kui ostate uue sarnase toote, või vastavasse elektri- ja elektroonikaseadmete jäätmete ning patareide ja akude ümbertöötlemiseks mõeldud kogumispunkti. Antud liiki jäätmete vale käitlemine võib kahjustada keskkonda ja inimeste tervist elektri- ja elektroonikajäätmetes tavaliselt leiduvate potentsiaalselt ohtlike ainete tõttu. Antud tootest tekkinud jäätmete nõuetekohase kõrvaldamisega aitate kasutada loodusvarasid efektiivselt. Täiendava teabe saamiseks elektri- ja elektroonikaseadmetest tekkinud jäätmete ning patarei- ja akujäätmete tagastamise ja ümbertöötlemise kohta võtke ühendust kohaliku omavalitsusega, asjakohase valitsusasutusega, asjakohase tootjavastutusorganisatsiooniga või olmejäätmete käitlejaga. Lisateavet leitate ka Interneti-leheküljelt www.canon-europe.com/weee või www.canon-europe.com/battery.

Tikai Eiropas Savienībai un EEZ (Norvēģijai, Islandei un Lihtenšteinai)



Šie simboli norāda, ka atbilstoši ES Direktīvai (2012/19/ES) par elektrisko un elektronisko iekārtu atkritumiem (EEIA), Direktīvai (2006/66/EK) par baterijām un akumulātoriem, un akumulātoru atkritumiem, ar ko atceļ Direktīvu 91/157/EEK, un vietējiem tiesību aktiem šo izstrādājumu nedrīkst izmest kopā ar sadzīves atkritumiem. Ja zem iepriekš norādītā simbola ir uzdrukāts ķīmiskais simbols, saskaņā ar direktīvu par baterijām un akumulātoriem tas nozīmē, ka šīs baterijas vai akumulātoru satur smagos metālus (Hg = dzīvsudrabs, Cd = kadmījs, Pb = svins) un to koncentrācijas līmenis pārsniedz direktīvā

par baterijām un akumulatoriem minēto piemērojamo sliekšni. Šis izstrādājums ir jānodod piemērotā savākšanas vietā, piemēram, apstiprinātā veikalā, kur iegādājaties līdzīgu jaunu produktu un atstājat veco, vai apstiprinātā vietā izlietotu elektrisko un elektronisko iekārtu un bateriju un akumulatoru pārstrādei. Nepareiza šāda veida atkritumu apsaimniekošana var apdraudēt vidi un cilvēka veselību tādu iespējami bīstamu vielu dēļ, kas parasti ir elektriskajās un elektroniskajās iekārtās. Jūsu atbalsts pareizā šāda veida atkritumu apsaimniekošanā sekmēs efektīvu dabas resursu izmantošanu. Lai saņemtu pilnīgāku informāciju par šāda veida izstrādājumu nodošanu otrreizējai pārstrādei, sazinieties ar vietējo pašvaldību, atkritumu savākšanas atbildīgo dienestu, pilnvaroto organizāciju vai iestādi, kas veic sadzīves atkritumu apsaimniekošanu, vai apmeklējiet tīmekļa vietni www.canon-europe.com/weee, vai www.canon-europe.com/battery.

Tik Europos Sajungai ir EEE (Norvegijai, Islandijai ir Lichtenšteinui)



Šie simboli reiškia, kad šio gaminio negalima išmesti į buitines atliekas, kaip reikalaujama WEEE Direktyvoje (2012/19/ES) ir Baterijų direktyvoje (2006/66/EB) ir (ar) jūsų šalies nacionaliniuose įstatymuose, kuriais šios Direktyvos yra įgyvendinamos. Jeigu cheminio ženklo simbolis yra nurodytas žemiau šio ženklo, tai reiškia, kad vadovaujantis Baterijų direktyvą, baterijų ar akumuliatorių sudėtyje yra sunkiųjų metalų (Hg = gyvsidabris, Cd = kadmio, Pb = švino), kurių koncentracija viršija Baterijų direktyvoje nurodytas leistinas ribas. Šį gaminį reikia pristatyti į specialųjį surinkimo punktą, pavyzdžiui, mainais, kai jūs perkate naują panašų gaminį, arba į specialiąją surinkimo vietą, kurioje perdirbamos elektrinės ir elektroninės įrangos atliekos bei naudotos baterijos ir akumuliatoriai. Dėl netinkamo šio tipo atliekų tvarkymo gali nukentėti aplinka ir iškilti grėsmė žmogaus sveikatai dėl galimai kenksmingų medžiagų, iš esmės susijusių su elektrine ir elektronine įranga. Bendradarbiaudami ir teisingai utilizuodami šiuos gaminius, jūs padėsite efektyviai naudoti gamtinius išteklius. Daugiau informacijos apie gaminio perdirbimą jums gali suteikti vietinis biuras, atliekų tvarkymo bendrovė, sertifikuoti organai ar buitinių atliekų surinkimo įmonės. Taip pat siūloma apsilankyti interneto svetainėje www.canon-europe.com/weee, arba www.canon-europe.com/battery.

Samo za Evropsko unijo in EGP (Norveška, Islandija in Lihtenštajn)



Ti simboli pomenijo, da tega izdelka skladno z Direktivo OEEO (2012/19/EU), Direktivo 2006/66/ES in/ali nacionalno zakonodajo, ki uvaja ti direktivi, ne smete odlagati z nesortiranimi gospodinjskimi odpadki. Če je pod zgoraj prikazanim simbolom natisnjen kemijski simbol, to v skladu z Direktivo pomeni, da je v tej bateriji ali akumulatorju prisotna težka kovina (Hg = živo srebro, Cd = kadmij, Pb = svinec), in sicer v koncentraciji, ki je nad relevantno mejno vrednostjo, določeno v Direktivi. Ta izdelek je potrebno odnesti na izbrano zbirno mesto, t. j. pooblaščenemu trgovino, kjer ob nakupu novega (podobnega) izdelka vrnete starega, ali na pooblaščenemu zbirno mesto za ponovno uporabo odpadne električne in elektronske opreme (EEO) ter baterij in akumulatorjev. Neustrezno ravnanje s to vrsto odpadkov lahko negativno vpliva na okolje in človeško zdravje zaradi potencialno nevarnih snovi, ki so pogosto povezane z EEO.

Vaše sodelovanje pri pravilnem odlaganju tega izdelka predstavlja pomemben prispevek k smotni izrabi naravnih virov. Za več informacij o ponovni uporabi tega izdelka se obrnite na lokalni mestni urad, pristojno službo za odpadke, predstavnika pooblaščenega programa za obdelavo odpadkov ali na lokalno komunalno. Lahko pa tudi obiščete našo spletno stran www.canon-europe.com/weee, ali www.canon-europe.com/battery.

Само за Европейския съюз и ЕИП (Норвегия, Исландия и Лихтенщайн)



Тези символи показват, че този продукт не трябва да се изхвърля заедно с битовите отпадъци съгласно Директивата за ИУЕЕО (2012/19/ЕС), Директивата за батерии (2006/66/ЕО) и/или Вашето национално законодателство, прилагащо тези Директиви. Ако под показания горе символ е отпечатан символ за химически елемент, съгласно разпоредбите на Директивата за батерии, този втори символ означава наличието на тежък метал (Hg = живак, Cd = кадмий, Pb = олово) в батерията или акумулатора в концентрация над указаната граница за съответния елемент в Директивата. Този продукт трябва да бъде предаден в предназначен за целта пункт за събиране, например на база размяна, когато купувате нов подобен продукт, или в одобрен събирателен пункт за рециклиране на излязло от употреба електрическо и електронно оборудване (ИУЕЕО), батерии и акумулатори. Неправилното третиране на този тип отпадъци може да доведе до евентуални отрицателни последици за околната среда и човешкото здраве поради потенциално опасните вещества, които обикновено са свързани с ЕЕО. В същото време Вашето съдействие за правилното изхвърляне на този продукт ще допринесе за ефективното използване на природните ресурси. За повече информация относно това къде можете да предадете за рециклиране на този продукт, моля свържете се с Вашите местни власти, с органа, отговорен за отпадъците, с одобрената система за ИУЕЕО или с Вашата местна служба за битови отпадъци, или посетете www.canon-europe.com/weee, или www.canon-europe.com/battery.

Doar pentru Uniunea Europeană și EEA (Norvegia, Islanda și Liechtenstein)



Aceste simboluri indică faptul că acest produs nu trebuie aruncat împreună cu deșeurile menajere, în conformitate cu Directiva DEEE (2012/19/UE), Directiva referitoare la baterii (2006/66/CE) și/sau legile dvs. naționale ce implementează aceste Directive. Dacă un simbol chimic este imprimat sub simbolul de mai sus, în conformitate cu Directiva referitoare la baterii, acest simbol indică prezența în baterie sau acumulator a unui metal greu (Hg = Mercur, Cd = Cadmiu, Pb = Plumb) într-o concentrație mai mare decât pragul admis specificat în Directiva referitoare la baterii. Acest produs trebuie înmănat punctului de colectare adecvat, ex: printr-un schimb autorizat unu la unu atunci când cumpărați un produs nou similar sau la un loc de colectare autorizat pentru reciclarea reziduurilor de echipament electric și electronic (EEE) și baterii și acumulatori. Administrarea neadecvată a acestui tip de deșeuri, ar putea avea un

impact asupra mediului și asupra sănătății umane datorită substanțelor cu potențial de risc care sunt în general asociate cu EEE. Cooperarea dvs. în direcția reciclării corecte a acestui produs va contribui la o utilizare eficientă a resurselor naturale. Pentru mai multe informații despre reciclarea acestui produs, vă rugăm să contactați biroul dvs. local, autoritățile responsabile cu deșeurile, schema aprobată sau serviciul dvs. responsabil cu deșeurile menajere sau vizitați-ne la www.canon-europe.com/weee, sau www.canon-europe.com/battery.

Samo za Europsku uniju i EEA (Norveška, Island i Lihtenštajn)



Oznaka pokazuje da se ovaj proizvod ne smije odlagati s komunalnim i ostalim vrstama otpada, u skladu s direktivom WEEE (2012/19/EC), Direktivom o baterijama (2006/66/EC) i Pravilnikom o gospodarenju otpadnim baterijama i akumulatorima te Pravilnikom o gospodarenju otpadnim električnim i elektroničkim uređajima i opremom. Ako je ispod prethodno prikazane oznake otisnut kemijski simbol, u skladu s Direktivom o baterijama, to znači da se u ovoj bateriji ili akumulatoru nalazi teški metal (Hg = živa, Cd = kadmij, Pb = olovo) i da je njegova koncentracija iznad razine propisane u Direktivi o baterijama. Ovaj bi proizvod trebalo predati ovlaštenom skupljaču EE otpada ili prodavatelju koji je dužan preuzeti otpadni proizvod po sistemu jedan za jedan, ukoliko isti odgovara vrsti te je obavljao primarne funkcije kao i isporučena EE oprema. Otpadne baterije i akumulatori predaju se ovlaštenom skupljaču otpadnih baterija ili akumulatora ili prodavatelju bez naknade i obveze kupnje za krajnjeg korisnika. Neodgovarajuće rukovanje ovom vrstom otpada može utjecati na okoliš i ljudsko zdravlje zbog potencijalno opasnih supstanci koje se najčešće nalaze na takvim mjestima. Vaša suradnja u pravilnom zbrinjavanju ovog proizvoda pridonijet će djelotvornom iskorištavanju prirodnih resursa. Dodatne informacije o recikliranju ovog proizvoda zatražite od svog lokalnog gradskog ureda, službe za zbrinjavanje otpada, odobrenog programa ili komunalne službe za uklanjanje otpada ili pak na stranicama www.canon-europe.com/weee ili www.canon-europe.com/battery.

Korisnici u Srbiji



Ovaj simbol označava da ovaj proizvod ne sme da se odlaže sa ostalim kućnim otpadom, u skladu sa WEEE Direktivom (2012/19/EU), Direktivom o baterijama (2006/66/EC) i nacionalnim zakonima. Ukoliko je ispod gore navedenog simbola odštampan hemijski simbol, u skladu sa Direktivom o baterijama, ovaj simbol označava da su u ovoj bateriji ili akumulatoru prisutni teški metali (Hg – živa, Cd – kadmijum, Pb - olovo) u koncentracijama koje premašuju prihvatljivi prag naveden u Direktivi o baterijama. Ovaj proizvod treba predati određenom centru za prikupljanje, npr. po principu „jedan-za-jedan“ kada kupujete sličan novi proizvod, ili ovlašćenom centru za prikupljanje za reciklažu istrošene električne i elektronske opreme (EEE), baterija i akumulatora. Nepravilno rukovanje ovom vrstom otpada može imati negativne posledice po životnu sredinu i ljudsko zdravlje usled potencijalno opasnih materijala koji se uglavnom vezuju za EEE. Vaša saradnja na ispravnom odlaganju ovog proizvoda će doprineti efikasnom korišćenju prirodnih resursa. Više informacija o tome kako možete da reciklirate ovaj proizvod potražite od lokalnih gradskih

vlasti, komunalne službe, odobrenog plana reciklaže ili servisa za odlaganje kućnog otpada, ili posetite stranicu www.canon-europe.com/weee, ili www.canon-europe.com/battery.

Handling Precautions

- **When Repairing, Lending, or Disposing of the Printer**

When Repairing, Lending, or Disposing of the Printer

If you have entered personal data, passwords and/or other security settings on the printer, such information may be stored in the printer.

When sending the printer for repair, lending or transferring the printer to another person, or disposing of the printer, please be sure to follow the steps below in order to delete such information and prevent third parties from accessing it.

➔ [Initializing Printer's Setting](#)

Specifications

- Specifications
- Print Area

Specifications

- ➔ Printer specifications
 - ➔ [GP-6600S / GP-566S](#)
 - ➔ [GP-4600S / GP-546S](#)
 - ➔ [GP-2600S / GP-526S](#)
- ➔ [Printing performance](#)
- ➔ [Memory and hard disk](#)
- ➔ [Interface](#)
- ➔ [Network Specifications](#)
- ➔ [Operating Conditions](#)
- ➔ [Ink](#)
- ➔ [Paper](#)

▶▶▶ Important

- The following values may vary depending on the operating environment.

Printer specifications

GP-6600S / GP-566S

Power supply	100-240 V AC (50/60 Hz)
Power consumption	<p>When printing (wired LAN connection): Approx. 94 W</p> <p>Standby (wired LAN connection): Approx. 1.7 W</p> <p>Standby (all ports connected): Approx. 2.2 W</p> <p>When power is off: Approx. 0.1 W *1</p> <p>*1 The printer uses a trace amount of power even when turned off. To stop all power consumption, turn off the printer and unplug the power cord.</p>
Operating environment	<p>Temperature: 59 to 86 °F (15 to 30 °C)</p> <p>Humidity: 10 to 80 % RH (with no condensation)</p>
Dimensions (W x D x H)	<p>Printer only: Approx. 78.8 x 28.9 x 24.8 in. (1999 x 734 x 628 mm)</p> <p>Printer and Stand (when basket is not used): Approx. 78.8 x 30.2 x 46 in. (1999 x 766 x 1168 mm)</p> <p>Printer and Stand (when using basket: basket position 1) *: Approx. 78.8 x 38.8 x 46 in. (1999 x 984 x 1168 mm)</p> <p>Printer and Stand (when using basket: basket position 2/4/5) *: Approx. 78.8 x 48.2 x 46 in. (1999 x 1222 x 1168 mm)</p> <p>Printer and Stand (when using basket: basket position 3) *: Approx. 78.8 x 56.5 x 46 in. (1999 x 1434 x 1168 mm)</p> <p>* For details on the Basket Position, see Example Basket Configurations.</p>

	Stand may not be provided depending on the region where the printer is purchased.
Weight	<p>Printer only (without print head and ink tanks): Approx. 268 lb (122 kg)</p> <p>Stand and basket: Approx. 42 lb (19 kg)</p> <p>Roll unit: Approx. 62 lb (28 kg)</p>
Space for installation (W x D x H)	<p>Printer and Stand (when using basket: basket position 1) *: Approx. 94.5 x 66.3 x 61.5 in. (2399 x 1684 x 1560 mm)</p> <p>* For details on the Basket Position, see Example Basket Configurations.</p>

GP-4600S / GP-546S

Power supply	100-240 V AC (50/60 Hz)
Power consumption	<p>When printing (wired LAN connection): Approx. 94 W</p> <p>Standby (wired LAN connection): Approx. 1.7 W</p> <p>Standby (all ports connected): Approx. 2.2 W</p> <p>When power is off: Approx. 0.1 W *1</p> <p>*1 The printer uses a trace amount of power even when turned off. To stop all power consumption, turn off the printer and unplug the power cord.</p>
Operating environment	<p>Temperature: 59 to 86 °F (15 to 30 °C)</p> <p>Humidity: 10 to 80 % RH (with no condensation)</p>
Dimensions (W x D x H)	<p>Printer only: Approx. 62.8 x 28.9 x 24.8 in. (1593 x 734 x 628 mm)</p> <p>Printer and Stand (when basket is not used): Approx. 62.8 x 30.2 x 46 in. (1593 x 766 x 1168 mm)</p> <p>Printer and Stand (when using basket: basket position 1) *: Approx. 62.8 x 38.8 x 46 in. (1593 x 984 x 1168 mm)</p> <p>Printer and Stand (when using basket: basket position 2/4/5) *: Approx. 62.8 x 48.2 x 46 in. (1593 x 1222 x 1168 mm)</p> <p>Printer and Stand (when using basket: basket position 3) *: Approx. 62.8 x 56.5 x 46 in. (1593 x 1434 x 1168 mm)</p> <p>* For details on the Basket Position, see Example Basket Configurations.</p> <p>Stand may not be provided depending on the region where the printer is purchased.</p>
Weight	<p>Printer only (without print head and ink tanks): Approx. 229 lb (104 kg)</p> <p>Stand and basket: Approx. 40 lb (18 kg)</p> <p>Roll unit: Approx. 46 lb (21 kg)</p>

Space for installation (W x D x H)	Printer and Stand (when using basket: basket position 1) *: Approx. 78.5 x 66.3 x 61.5 in. (1993 x 1684 x 1560 mm) * For details on the Basket Position, see Example Basket Configurations .
---	---

GP-2600S / GP-526S

Power supply	100-240 V AC (50/60 Hz)
Power consumption	When printing (wired LAN connection): Approx. 91 W Standby (wired LAN connection): Approx. 1.7 W Standby (all ports connected): Approx. 2.2 W When power is off: Approx. 0.1 W *1 *1 The printer uses a trace amount of power even when turned off. To stop all power consumption, turn off the printer and unplug the power cord.
Operating environment	Temperature: 59 to 86 °F (15 to 30 °C) Humidity: 10 to 80 % RH (with no condensation)
Dimensions (W x D x H)	Printer only: Approx. 43.8 x 28.9 x 24.8 in. (1110 x 734 x 628 mm) Printer and Stand (when basket is not used): Approx. 43.8 x 30.2 x 46 in. (1110 x 766 x 1168 mm) Printer and Stand (when using basket: basket position 1) *: Approx. 43.8 x 38.8 x 46 in. (1110 x 984 x 1168 mm) Printer and Stand (when using basket: basket position 2/4/5) *: Approx. 43.8 x 48.2 x 46 in. (1110 x 1222 x 1168 mm) Printer and Stand (when using basket: basket position 3) *: Approx. 43.8 x 56.5 x 46 in. (1110 x 1434 x 1168 mm) * For details on the Basket Position, see Example Basket Configurations . Stand may not be provided depending on the region where the printer is purchased.
Weight	Printer only (without print head and ink tanks): Approx. 183 lb (83 kg) Stand and basket: Approx. 37 lb (17 kg) Roll unit: Approx. 37 lb (17 kg)
Space for installation (W x D x H)	Printer only: Approx. 59.5 x 56.5 x 40.2 in. (1510 x 1434 x 1020 mm) Printer and Stand (when using basket: basket position 1) *: Approx. 59.5 x 66.3 x 61.5 in. (1510 x 1684 x 1560 mm) * For details on the Basket Position, see Example Basket Configurations .

Printing performance

Print method	Bubblejet
Maximum resolution	2400 dpi (horizontally) * x 1200 dpi (vertically) * Prints with a minimum 1/2400 inch dot pitch between ink droplets.
Number of nozzles	18432 nozzles (MBK/C/M/Y/O: 1536 nozzles x2, PBK/GY: 1536 nozzles x1)

Memory and hard disk

Memory	3 GB
Hard disk capacity	500 GB Personal mail boxes (Permanent storage area): 308 GB
Print job storage capacity	Common Box: 100 jobs Personal Boxes: 100 jobs
Displayed job history	Operation panel: 10 jobs Remote UI: 500 jobs

Interface

USB and the network can be used at the same time.

You cannot use Wi-Fi and wired LAN at the same time.

USB	Hi-Speed USB * * To use Hi-Speed USB, your computer must support Hi-Speed USB. Additionally, the Hi-Speed USB interface is completely backward compatible with USB 1.1, so the printer can be connected even if the computer interface is USB 1.1.
USB memory	USB flash drive
LAN	Wired LAN: IEEE802.3ab (1000BASE-T) / IEEE802.3u (100BASE-TX) / IEEE802.3 (10BASE-T) Wi-Fi: IEEE802.11n / IEEE802.11g / IEEE802.11b

Network Specifications

Communication protocol	SNMP, HTTP, TCP/IP (IPv4/IPv6), FTP
Wired LAN specifications	Compliance standards: IEEE802.3ab (1000BASE-T) / IEEE802.3u (100BASE-TX) / IEEE802.3 (10BASE-T) Transmission speed: 10 Mbps / 100 Mbps / 1000 Mbps (automatically selected) Security: IEEE802.1X (EAP-TLS/EAP-TTLS/PEAP)

Wi-Fi specifications	<p>Compliance standards: IEEE802.11n / IEEE802.11g / IEEE802.11b</p> <p>Frequency range: 2.4 GHz</p> <p>Channels: 1-11 or 1-13 *</p> <p>* Varies by country and region.</p> <p>Effective range: Indoors 164 feet/50 m *</p> <p>* Varies according to environmental conditions.</p> <p>Security:</p> <p>WPA-PSK (TKIP/AES)</p> <p>WPA2-PSK (TKIP/AES)</p> <p>WPA3-SAE (AES)</p> <p>WPA-EAP (AES) *</p> <p>WPA2-EAP (AES) *</p> <p>WPA3-EAP (AES) *</p> <p>* Supports IEEE802.1X (EAP-TLS / EAP-TTLS / PEAP)</p> <p>Setup:</p> <p>WPS (push button method/PIN code method)</p> <p>Easy wireless connect</p>
-----------------------------	---

Operating Conditions

If operating conditions of the operating system are high, follow those.

Windows

Compatible Operating System (Standard supplied printer driver)	<p>Windows 11</p> <p>Windows 10</p> <p>Windows 8.1</p> <p>Windows 7</p> <p>Windows Server 2022</p> <p>Windows Server 2019</p> <p>Windows Server 2016</p> <p>Windows Server 2012 R2</p> <p>Windows Server 2012</p> <p>Windows Server 2008 R2</p> <p>Use the latest Service Pack available.</p>
Free hard disk space	20 GB or more

macOS

Compatible Operating System (Standard supplied printer driver)	macOS Catalina 10.15.7 - macOS Ventura 13
Free hard disk space	20 GB or more

Other Supported OS

iOS, iPadOS, Android

Some functions may not be available with the supported OS.

- An Internet connection is required to use the Online Manual.
- To install the software while using Windows, you must have a CD-ROM drive or a network connection.
- To install the software while using macOS, you must have a network connection.

Ink

For information on the ink the printer supports, see [Ink Tanks](#).

Paper

For details on the compatible media types, see Paper Information List.

For details on the paper widths supported by the printer, see [Paper Sizes](#).

For details about Print Area, see [Print Area](#).

Print Area

A margin required by the printer is added with respect to the size of paper loaded in the printer. Except in borderless printing, the actual printing area corresponds to the paper size minus the space for this margin.

▶▶▶ Note

- Printable Area: The area that can be printed.
- For borderless printing with roll paper, the margin is 0 in. (0 mm).
 - ➔ [Printing without Edges Based on the Scenarios \(Windows\)](#)
 - ➔ [Printing without Edges Based on the Scenarios \(macOS\)](#)
- Recommended Print Area: We recommend printing within this area.
- To match the document size with the actual printing area, print on oversize paper with the required margin added.
 - ➔ [Printing to Oversized Paper Sizes \(Windows\)](#)
 - ➔ [Printing to Oversized Paper Sizes \(macOS\)](#)

Sheets

Printable Area:

A margin of 0.2 in. (3 mm) on top, 0.5 in. (12.7 mm) on bottom*, and 0.2 in. (3 mm) on left and right sides is required.

Recommended Print Area:

A margin of 0.8 in. (20 mm) on top, 0.8 in. (20 mm) on bottom*, and 0.2 in. (3 mm) on left and right sides is required.

* The bottom margin for cut sheet depends on an OS and applications.

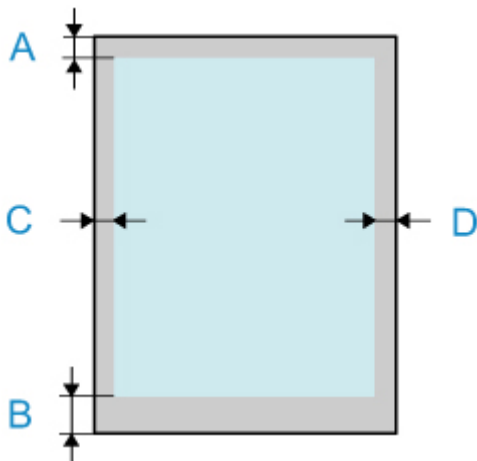

- A: Top Edge
- B: Bottom Edge
- C: Left Edge
- D: Right Edge

Rolls

Printable Area:

A margin of 0.2 in. (3 mm) on top and bottom and 0.2 in. (3 mm) on left and right sides is required. For borderless printing, the margins on top, bottom, left, and right are 0 in. (0 mm). For paper that supports borderless printing, see Paper Information List.

Recommended Print Area:

A margin of 0.8 in. (20 mm) on top, 0.2 in. (3 mm) on bottom, and 0.2 in. (3 mm) on left and right sides is required.

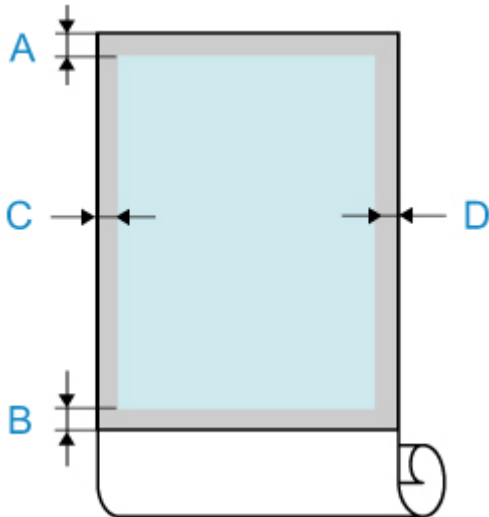

- A: Top Edge
- B: Bottom Edge
- C: Left Edge
- D: Right Edge

Appendix

- [Online Manual](#)
- [Symbols Used in This Document](#)
- [Trademarks and Licenses](#)

Online Manual

This manual is designed to display correctly on the following operating systems and browsers.

- Windows
Microsoft Edge, Google Chrome, and Mozilla Firefox
- Windows in S mode
Microsoft Edge
- macOS/iOS/iPadOS
Safari
- Android/Chrome OS
Google Chrome

* In your browser, set to allow cookies, and enable JavaScript.

* Enable TLS1.2 or higher.

* Models used in illustrations and videos in this manual, may differ from your model.

Screenshots in This Manual

For Windows:

The screenshots used in this manual are taken with Windows 10.

For macOS:

The screenshots used in this manual are taken with macOS Ventura 13.