

40G-QSFP-LR4-AO

Brocade® (Formerly) 40G-QSFP-LR4 Compatible TAA Compliant 40GBase-LR4 QSFP+ Transceiver (SMF, 1270nm to 1330nm, 10km, LC, DOM)

Features

- SFF-8436 Compliance
- Duplex LC Connector
- Commercial Temperature 0 to 70 Celsius
- Single-mode Fiber
- Hot Pluggable
- Excellent ESD Protection
- Metal with Lower EMI
- RoHS Compliant and Lead Free



Applications

- 40GBase Ethernet
- Access and Enterprise

Product Description

This Brocade® (Formerly) 40G-QSFP-LR4 compatible QSFP+ transceiver provides 40GBase-LR4 throughput up to 10km over single-mode fiber (SMF) using a wavelength of 1270nm to 1330nm via an LC connector. It is guaranteed to be 100% compatible with the equivalent Brocade® (Formerly) transceiver. This easy to install, hot swappable transceiver has been programmed, uniquely serialized and data-traffic and application tested to ensure that it will initialize and perform identically. Digital optical monitoring (DOM) support is also present to allow access to real-time operating parameters. This transceiver is Trade Agreements Act (TAA) compliant. We stand behind the quality of our products and proudly offer a limited lifetime warranty.

AddOn's transceivers are RoHS compliant and lead-free.

TAA refers to the Trade Agreements Act (19 U.S.C. & 2501-2581), which is intended to foster fair and open international trade. TAA requires that the U.S. Government may acquire only "U.S. – made or designated country end products."



Regulatory Compliance

- ESD to the Electrical PINs: compatible with MIL-STD-883E Method 3015.4
- ESD to the LC Receptacle: compatible with IEC 61000-4-3
- EMI/EMC compatible with FCC Part 15 Subpart B Rules, EN55022:2010
- Laser Eye Safety compatible with FDA 21CFR, EN60950-1& EN (IEC) 60825-1,2
- RoHS compliant with EU RoHS 2.0 directive 2015/863/EU

Absolute Maximum Ratings

| Parameter | Symbol | Min. | Typ. | Max. | Unit |
|---------------------|--------|------|------|------|------|
| Storage Temperature | TS | -40 | | 85 | °C |
| Relative Humidity | Rh | 0 | | 85 | % |
| Supply Voltage | Vcc | -0.5 | | 4.0 | V |

Recommended Operating Conditions

| Parameter | Symbol | Min. | Typ. | Max. | Unit |
|----------------------------|--------|------|------|------|------|
| Power Supply Voltage | Vcc | 3.13 | 3.3 | 3.47 | V |
| Power Supply Current | Icc | | | 100 | mA |
| Case Operating Temperature | Tc | -5 | | 70 | °C |

Optical Characteristics

| Parameter | Symbol | Min. | Typ. | Max. | Unit | Notes |
|---|-----------|--|------|--------|-------|-----------------|
| Wavelength | L0 | 1264.5 | 1271 | 1277.5 | nm | |
| | L1 | 1284.5 | 1291 | 1297.5 | nm | |
| | L2 | 1304.5 | 1311 | 1317.5 | nm | |
| | L3 | 1324.5 | 1331 | 1337.5 | nm | |
| Transmitter | | | | | | |
| Side-mode Suppression Ratio | SMSR | 30 | | | dB | |
| Total Average Launch Power | P_T | | | 8.3 | dBm | |
| Average Launch Power, each Lane | | -7 | | 2.3 | dBm | |
| Optical Modulation Amplitude, each Lane | OMA | -4 | | 3.5 | dBm | |
| Difference in launch Power between any two lanes (OMA) | | | | 6.5 | dB | |
| Launch Power in OMA minus Transmitter and Dispersion Penalty (TDP), each Lane | | -4.8 | | | dBm | |
| TDP, each Lane | TDP | | | 2.3 | dB | |
| Extinction Ratio | ER | 3.5 | | | dB | |
| Relative Intensity Noise | R_{in} | | | -128 | dB/Hz | 12dB reflection |
| Optical Return Loss Tolerance | | | | 20 | dB | |
| Transmitter Reflectance | R_T | | | -12 | dB | |
| Transmitter Eye Mask Definition X1, X2, X3, Y1, Y2, Y3 | | Specification Values 0.25, 0.4, 0.45, 0.25, 0.28, 0.4 | | | | |
| Average Launch Power OFF Transmitter, each Lane | P_{off} | | | -30 | dBm | |
| Receiver | | | | | | |
| Damage Threshold | TH_d | 3.3 | | | dBm | 1 |
| Average Power at receiver Input, each Lane | | -13.7 | | 2.3 | dB | |
| Receiver Reflectance | R_R | | | -26 | dB | |
| Receiver Power (OMA), each Lane | | | | 3.5 | dBm | |
| Stressed Receiver Sensitivity in OMA, each Lane | | | | -9.9 | dBm | |
| Receiver Sensitivity, each Lane | S_R | | | -11.5 | dBm | |
| Difference in Receive Power between any Lanes (OMA) | | | | -7.5 | dBm | |
| Condition of Stress Receiver Sensitivity Test | | | | | | |
| Vertical Eye Closure Penalty, each Lane | | | 1.6 | | dB | |
| Stressed Eye Jitter, each Lane | | | 0.3 | | UI | |

Notes:

1. The receiver shall be able to tolerate, without damage, continuous exposure to a modulated optical input signal having this power level on one lane. The receiver does not have to operate correctly at this input power.

Electrical Characteristics

| Parameter | Symbol | Min. | Typ. | Max. | Unit | Notes |
|--|----------------------------|------|------|------|--------|--------------------------------|
| Power Consumption (XLPP1) | | | | 1.5 | W | |
| Supply Current | ICC | | 0.75 | 1.0 | A | |
| Control I/O Voltage, High | VIH | 2.0 | | VCC | V | |
| Control I/O Voltage, Low | VIL | 0 | | 0.7 | V | |
| Inter-Channel Skew | TSK | | | 150 | ps | |
| RESETL Duration | | | 10 | | us | |
| RESETL De-assert time | | | | 100 | ms | |
| Power on time | | | | 100 | ms | |
| Transmitter | | | | | | |
| Single Ended Output Voltage Tolerance | | -0.3 | | 4 | V | |
| AC Common mode Voltage Tolerance (RMS) | | 15 | | | mV | |
| Tx Input Diff Voltage | VI | 90 | | 1600 | mV | |
| Tx Input Diff Impedance | ZIN | 80 | 100 | 120 | Ω | |
| Differential Input Return Loss | See IEEE 802.3ba 86A.4.11 | | | | dB | 10MHz-11.1GHz |
| J2 Jitter tolerance | Jt2 | | | 0.18 | UI | |
| J9 Jitter Tolerance | Jt9 | | | 0.26 | UI | |
| Data Dependent Pulse Width Shrinkage | DDPWS | | | 0.07 | UI | |
| Eye Mask Coordinates: X1, X2, Y1, Y2 | 0.1, 0.31, 95, 350 | | | | | |
| Receiver (XLPP1) | | | | | | |
| Single Ended Output Voltage Tolerance | | -0.3 | | 4 | V | Preferred to TP1 signal common |
| AC Common mode Voltage Tolerance (RMS) | | | | 7.5 | mV | |
| Termination Mismatch at 1MHz | | | | 5 | % | |
| Differential Output Return Loss | See IEEE 802.3ba 86A.4.2.1 | | | | dB | 10MHz-11.1GHz |
| Common-mode Output Return Loss | See IEEE 802.3ba 86A.4.2.1 | | | | dB | 10MHz-11.1GHz |
| Rx Output Diff Voltage | Vo | | 600 | 800 | mV | |
| Rx Output Rise and Fall Time | Tr/Tf | | | 35 | ps | 20% to 80% |
| J2 Jitter Tolerance | Jr2 | | | 0.46 | UI | |
| J9 Jitter Tolerance | Jr9 | | | 0.63 | UI | |
| Eye Mask Coordinates: X1, X2, Y1, Y2 | 0.29, 0.5, 150, 425 | | | | UI, mV | |

Notes:

1. The single ended input voltage tolerance is the allowable range of the instantaneous input signals

Pin Descriptions

| Pin | Logic | Symbol | Name/Descriptions | Ref. |
|-----|-------------|---------|--|------|
| 1 | | GND | Module Ground | 1 |
| 2 | CML-I | Tx2- | Transmitter inverted data input | |
| 3 | CML-I | Tx2+ | Transmitter non-inverted data input | |
| 4 | | GND | Module Ground | 1 |
| 5 | CML-I | Tx4- | Transmitter inverted data input | |
| 6 | CML-I | Tx4+ | Transmitter non-inverted data input | |
| 7 | | GND | Module Ground | 1 |
| 8 | LVTTTL-I | MODSEIL | Module Select | 2 |
| 9 | LVTTTL-I | ResetL | Module Reset | 2 |
| 10 | | VCCRx | +3.3v Receiver Power Supply | |
| 11 | LVC MOS-I | SCL | 2-wire Serial interface clock | 2 |
| 12 | LVC MOS-I/O | SDA | 2-wire Serial interface data | 2 |
| 13 | | GND | Module Ground | 1 |
| 14 | CML-O | RX3+ | Receiver non-inverted data output | |
| 15 | CML-O | RX3- | Receiver inverted data output | |
| 16 | | GND | Module Ground | 1 |
| 17 | CML-O | RX1+ | Receiver non-inverted data output | |
| 18 | CML-O | RX1- | Receiver inverted data output | |
| 19 | | GND | Module Ground | 1 |
| 20 | | GND | Module Ground | 1 |
| 21 | CML-O | RX2- | Receiver inverted data output | |
| 22 | CML-O | RX2+ | Receiver non-inverted data output | |
| 23 | | GND | Module Ground | 1 |
| 24 | CML-O | RX4- | Receiver inverted data output | |
| 25 | CML-O | RX4+ | Receiver non-inverted data output | |
| 26 | | GND | Module Ground | 1 |
| 27 | LVTTTL-O | ModPrsL | Module Present, internal pulled down to GND | |
| 28 | LVTTTL-O | IntL | Interrupt output should be pulled up on host board | 2 |
| 29 | | VCCTx | +3.3v Transmitter Power Supply | |
| 30 | | VCC1 | +3.3v Power Supply | |
| 31 | LVTTTL-I | LPMode | Low Power Mode | 2 |
| 32 | | GND | Module Ground | 1 |
| 33 | CML-I | Tx3+ | Transmitter non-inverted data input | |
| 34 | CML-I | Tx3- | Transmitter inverted data input | |
| 35 | | GND | Module Ground | 1 |
| 36 | CML-I | Tx1+ | Transmitter non-inverted data input | |
| 37 | CML-I | Tx1- | Transmitter inverted data input | |
| 38 | | GND | Module Ground | 1 |

Notes:

1. Module circuit ground is isolated from module chassis ground with in the module.
2. Open collector; should be pulled up with 4.7k-10k ohms on host board to a voltage between 3.15V and 3.6V.

Electrical Pin-out Details

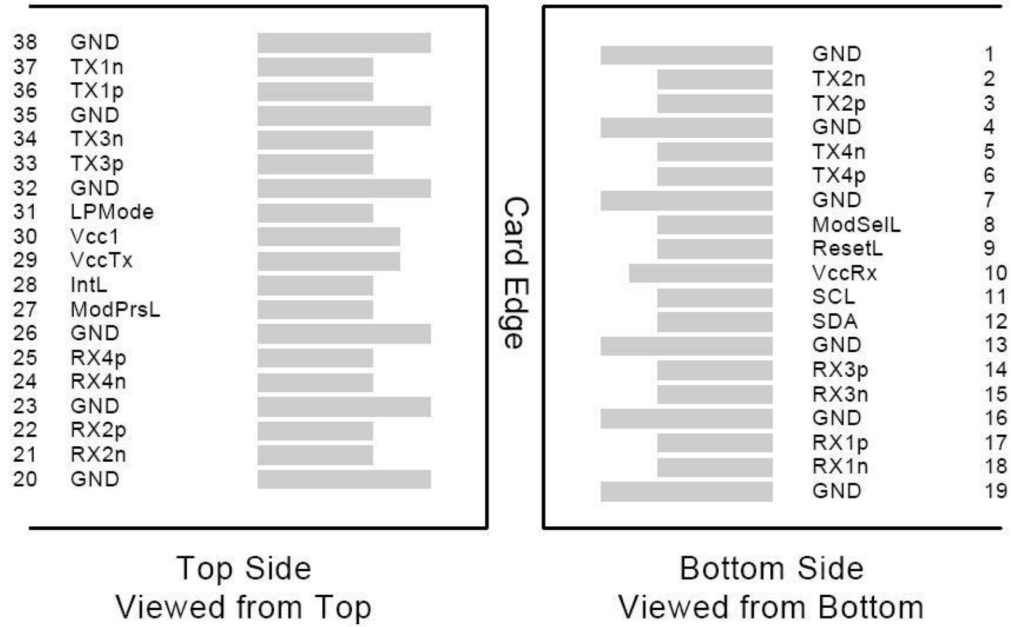

EEPROM Information

2-Wire Serial Address: 1010000x

| | | |
|-----|---------------------------------------|------------|
| 0 | ID and status | (3 Bytes) |
| 2 | | |
| 21 | Interrupt Flags | (19 Bytes) |
| 33 | Module Monitors | (12 Bytes) |
| 81 | Channel Monitors | (48 Bytes) |
| 85 | Reserved | (4 Bytes) |
| 97 | Control | (12 Bytes) |
| 99 | Reserved | (2 Bytes) |
| 106 | Free Side Device and Channel Mask | (7 Bytes) |
| 107 | Reserved | (1 Bytes) |
| 111 | Free Side Device Properties | (4 Bytes) |
| 118 | Reserved | (7 Bytes) |
| 122 | Password Change Entry Area (Optional) | (4 Bytes) |
| 126 | Password Entry Area (Optional) | (4 Bytes) |
| 127 | Page Select Byte | (1 Bytes) |

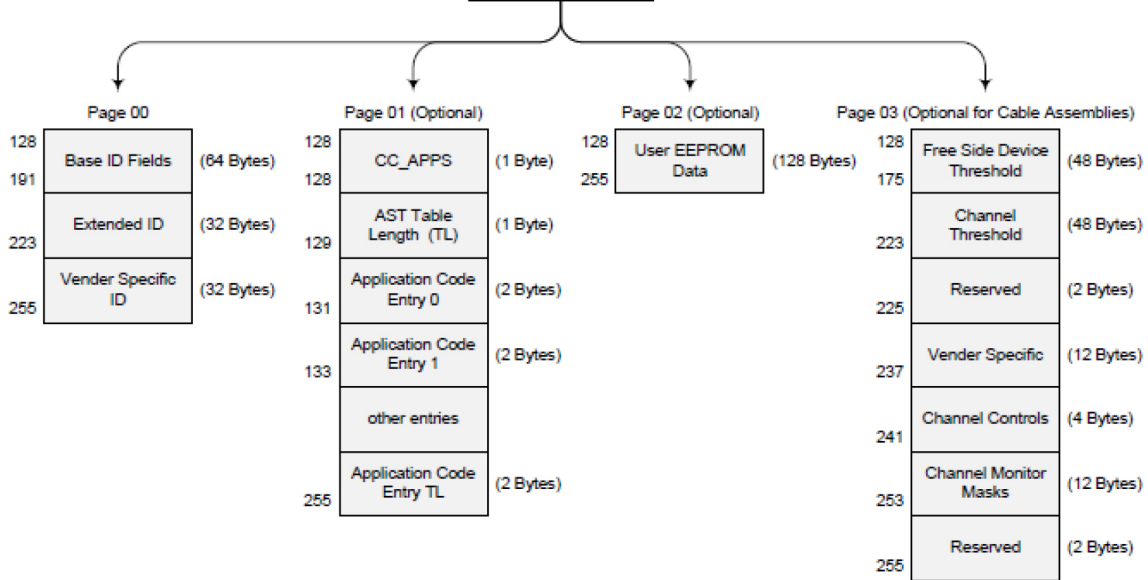

Mechanical Specifications

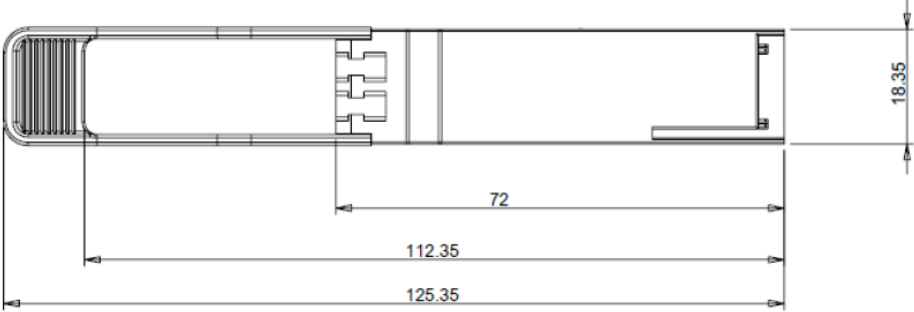
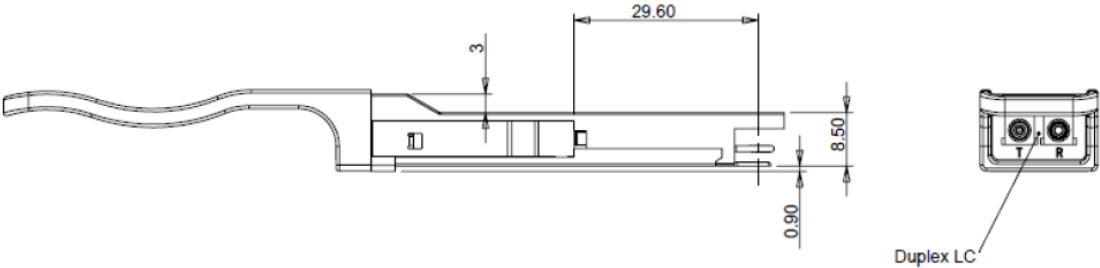

About AddOn Networks

In 1999, AddOn Networks entered the market with a single product. Our founders fulfilled a severe shortage for compatible, cost-effective optical transceivers that compete at the same performance levels as leading OEM manufacturers. Adhering to the idea of redefining service and product quality not previously had in the fiber optic networking industry, AddOn invested resources in solution design, production, fulfillment, and global support.

Combining one of the most extensive and stringent testing processes in the industry, an exceptional free tech support center, and a consistent roll-out of innovative technologies, AddOn has continually set industry standards of quality and reliability throughout its history.

Reliability is the cornerstone of any optical fiber network and is engrained in AddOn's DNA. It has played a key role in nurturing the long-term relationships developed over the years with customers. AddOn remains committed to exceeding industry standards with certifications from ranging from NEBS Level 3 to ISO 9001:2005 with every new development while maintaining the signature reliability of its products.

U.S. Headquarters

Email: sales@addonnetworks.com

Telephone: +1 877.292.1701

Fax: 949.266.9273

Europe Headquarters

Email: salesupportemea@addonnetworks.com

Telephone: +44 1285 842070