

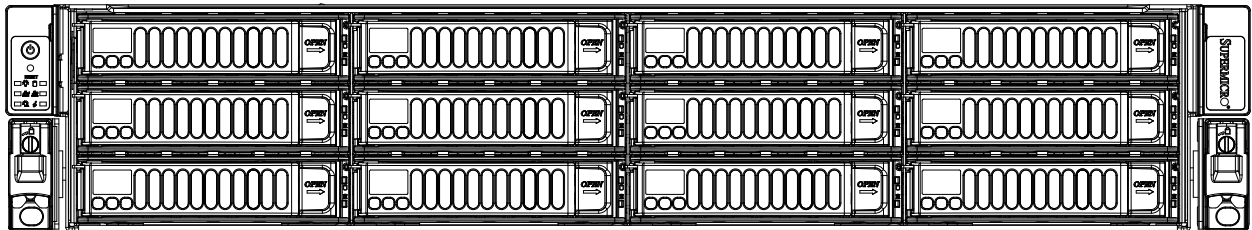

SuperStorage
SSG-6029P-E1CR24H
SSG-6029P-E1CR24L



USER'S MANUAL

Revision 1.0b

The information in this User's Manual has been carefully reviewed and is believed to be accurate. The vendor assumes no responsibility for any inaccuracies that may be contained in this document, and makes no commitment to update or to keep current the information in this manual, or to notify any person or organization of the updates. **Please Note: For the most up-to-date version of this manual, please see our website at www.supermicro.com.**

Super Micro Computer, Inc. ("Supermicro") reserves the right to make changes to the product described in this manual at any time and without notice. This product, including software and documentation, is the property of Supermicro and/or its licensors, and is supplied only under a license. Any use or reproduction of this product is not allowed, except as expressly permitted by the terms of said license.

IN NO EVENT WILL Super Micro Computer, Inc. BE LIABLE FOR DIRECT, INDIRECT, SPECIAL, INCIDENTAL, SPECULATIVE OR CONSEQUENTIAL DAMAGES ARISING FROM THE USE OR INABILITY TO USE THIS PRODUCT OR DOCUMENTATION, EVEN IF ADVISED OF THE POSSIBILITY OF SUCH DAMAGES. IN PARTICULAR, SUPER MICRO COMPUTER, INC. SHALL NOT HAVE LIABILITY FOR ANY HARDWARE, SOFTWARE, OR DATA STORED OR USED WITH THE PRODUCT, INCLUDING THE COSTS OF REPAIRING, REPLACING, INTEGRATING, INSTALLING OR RECOVERING SUCH HARDWARE, SOFTWARE, OR DATA.

Any disputes arising between manufacturer and customer shall be governed by the laws of Santa Clara County in the State of California, USA. The State of California, County of Santa Clara shall be the exclusive venue for the resolution of any such disputes. Supermicro's total liability for all claims will not exceed the price paid for the hardware product.

FCC Statement: This equipment has been tested and found to comply with the limits for a Class A digital device pursuant to Part 15 of the FCC Rules. These limits are designed to provide reasonable protection against harmful interference when the equipment is operated in a commercial environment. This equipment generates, uses, and can radiate radio frequency energy and, if not installed and used in accordance with the manufacturer's instruction manual, may cause harmful interference with radio communications. Operation of this equipment in a residential area is likely to cause harmful interference, in which case you will be required to correct the interference at your own expense.

California Best Management Practices Regulations for Perchlorate Materials: This Perchlorate warning applies only to products containing CR (Manganese Dioxide) Lithium coin cells. "Perchlorate Material-special handling may apply. See www.dtsc.ca.gov/hazardouswaste/perchlorate".



WARNING: This product can expose you to chemicals including lead, known to the State of California to cause cancer and birth defects or other reproductive harm. For more information, go to www.P65Warnings.ca.gov.

The products sold by Supermicro are not intended for and will not be used in life support systems, medical equipment, nuclear facilities or systems, aircraft, aircraft devices, aircraft/emergency communication devices or other critical systems whose failure to perform be reasonably expected to result in significant injury or loss of life or catastrophic property damage. Accordingly, Supermicro disclaims any and all liability, and should buyer use or sell such products for use in such ultra-hazardous applications, it does so entirely at its own risk. Furthermore, buyer agrees to fully indemnify, defend and hold Supermicro harmless for and against any and all claims, demands, actions, litigation, and proceedings of any kind arising out of or related to such ultra-hazardous use or sale.

Manual Revision 1.0b

Release Date: February 14, 2020

Unless you request and receive written permission from Super Micro Computer, Inc., you may not copy any part of this document. Information in this document is subject to change without notice. Other products and companies referred to herein are trademarks or registered trademarks of their respective companies or mark holders.

Copyright © 2020 by Super Micro Computer, Inc.
All rights reserved.

Printed in the United States of America

Preface

About this Manual

This manual is written for professional system integrators and PC technicians. It provides information for the installation and use of the SuperStorage SSG-6029P-E1CR24H/L. Installation and maintenance should be performed by experienced technicians only.

Please refer to the SSG-6029P-E1CR24H/L server specifications page on our website for updates on supported memory, processors and operating systems (<http://www.supermicro.com>).

Notes

For your system to work properly, please follow the links below to download all necessary drivers/utilities and the user's manual for your server.

- Supermicro product manuals: <http://www.supermicro.com/support/manuals/>
- Product drivers and utilities: <https://www.supermicro.com/wftp/driver>
- Product safety info: http://www.supermicro.com/about/policies/safety_information.cfm

If you have any questions, please contact our support team at:
support@supermicro.com

This manual may be periodically updated without notice. Please check the Supermicro website for possible updates to the manual revision level.

Warnings

Special attention should be given to the following symbols used in this manual.



Warning! Indicates important information given to prevent equipment/property damage or personal injury.



Warning! Indicates high voltage may be encountered when performing a procedure.

Contents

Chapter 1 Introduction

1.1 Overview.....	8
1.2 Unpacking the System	9
1.3 System Features	10
1.4 Server Chassis Features.....	11
Control Panel	11
Front Features.....	12
Rear Features	13
1.5 Motherboard Layout	14
Quick Reference Table.....	15

Chapter 2 Server Installation

2.1 Overview.....	18
2.2 Preparing for Setup	18
Choosing a Setup Location.....	18
Rack Precautions	19
Server Precautions.....	19
Rack Mounting Considerations	19
Ambient Operating Temperature.....	19
Airflow	19
Mechanical Loading.....	20
Circuit Overloading	20
Reliable Ground.....	20
2.3 Installing the System into a Rack.....	21
Separating the Sections of the Rack Rails.....	21
Releasing the Inner Rail.....	22
Installing The Inner Rails on the Chassis	23
Installing the Outer Rails on the Rack	24
Installing into the Rack.....	25
Removing the Chassis From the Rack.....	26
Removing the Outer Rails From the Rack.....	27
2.4 Installing the Cable Management Arm	28

Chapter 3 Maintenance and Component Installation

3.1 Removing Power	31
3.2 Accessing the System.....	32
Removing the Top Covers.....	32
Mid-chassis Cover	32
Rear Cover	33
Removing the Rear Cover.....	33
3.3 Motherboard Components.....	34
Processor and Heatsink Installation.....	34
The Intel® Xeon® 81xx/61xx/51xx/41xx/31xx and 82xx/62xx/52xx/42xx/32xx series Series Processors.....	34
Overview of the Processor Socket Assembly.....	35
Overview of the Processor Heatsink Module (PHM).....	36
Assembling the Processor Package.....	37
Installing the Processor Heatsink Module (PHM)	38
Removing the Processor Heatsink Module from the Motherboard	39
Memory Support and Installation	40
ESD Precautions.....	40
Precautions	40
Introduction to Intel® Optane DC Persistent Memory	40
Memory Support	40
DIMM Installation	41
DIMM Module Removal.....	41
Memory Installation Sequence	42
General Memory Population Requirements	43
DIMM Population Guidelines for Optimal Performance	43
Mezzanine Card Installation (Optional).....	46
Motherboard Battery	48
3.4 Chassis Components	49
Removing Power from the System	49
Storage Drives	49
Drive Carriers	49
Installing a Hard Disk Drive.....	50

Installing Rear Hard Drives	52
Installing the Expansion Cards	53
Installing a SIOM Card.....	54
Installing Front Optional NVMe Drives with Cable	55
System Fans	59
Installing the Air Shrouds	60
Power Supply	62
Chapter 4 Motherboard Connections	
4.1 Power Connections	63
4.2 Ports	64
Rear I/O Ports	64
4.3 Headers	66
4.4 Front Control Panel	71
4.5 Jumpers	74
Explanation of Jumpers	74
4.6 LED Indicators.....	76
Chapter 5 Software	
5.1 Microsoft Windows OS Installation.....	78
5.2 Driver Installation.....	80
5.3 SuperDoctor® 5.....	81
5.4 IPMI	81
Chapter 6 UEFI BIOS	
6.1 Introduction.....	82
Starting the Setup Utility	82
6.2 Main Menu.....	83
6.3 Advanced Settings Menu	84
6.4 Event Logs	118
6.5 IPMI	120
6.6 Security Settings	123
6.7 Boot Settings	126
6.8 Save & Exit.....	129
Appendix A BIOS Error Codes	
Appendix B Standardized Warning Statements for AC Systems	
Appendix C System Specifications	
Appendix D UEFI BIOS Recovery	

Contacting Supermicro

Headquarters

Address: Super Micro Computer, Inc.
980 Rock Ave.
San Jose, CA 95131 U.S.A.

Tel: +1 (408) 503-8000

Fax: +1 (408) 503-8008

Email: marketing@supermicro.com (General Information)
support@supermicro.com (Technical Support)

Website: www.supermicro.com

Europe

Address: Super Micro Computer B.V.
Het Sterrenbeeld 28, 5215 ML
's-Hertogenbosch, The Netherlands

Tel: +31 (0) 73-6400390

Fax: +31 (0) 73-6416525

Email: sales@supermicro.nl (General Information)
support@supermicro.nl (Technical Support)
rma@supermicro.nl (Customer Support)

Website: www.supermicro.nl

Asia-Pacific

Address: Super Micro Computer, Inc.
3F, No. 150, Jian 1st Rd.
Zhonghe Dist., New Taipei City 235
Taiwan (R.O.C)

Tel: +886-(2) 8226-3990

Fax: +886-(2) 8226-3992

Email: support@supermicro.com.tw

Website: www.supermicro.com.tw

Chapter 1

Introduction

1.1 Overview

This chapter provides a brief outline of the functions and features of the SuperStorage SSG-6029P-E1CR24H/L. The SSG-6029P-E1CR24H/L is a high-end solution comprised of two main subsystems: the SC826SE1C4-R1K62 2U chassis and the X11DSC+ dual processor motherboard. It features hot-swap SAS3 drives, and is powered by dual redundant 1600 Watt high-efficiency, hot-swap power modules.

In addition to the motherboard and chassis, several important parts that are included with the system are listed below. The only difference between the two servers models is their add-on card for each.

Main Parts List		
Description	Part Number	Quantity
2U air shroud BKT left	MCP-120-22601-0N	1
2U air shroud BKT right	MCP-120-22602-0N	1
Black gen 8 hot-swap 3.5" HDD tray	MCP-220-00133-0B	24
Black gen-3 hot-swap 2.5" Tool-less HDD tray	MCP-220-00147-0B	2
Mylar Air Shroud	MCP-310-00077-0B	1
Rail set	MCP-290-00139-0N	1
80 x 80 x 38-mm, 13.5K RPM, Middle Cooling Fans	FAN-0168L4	5
AC-DC 1600W, Titanium Level, Redundant, 1U power supplies	PWS-1K62A-1R	2
2-Port 12Gbps Backplane for 2 x 2.5" SAS/SATA HDD/SSD	BPN-SAS3-826TQ-B2B	1
2U 12-Port Expander Backplane supports 8 x 3.5" SAS3/SATA3 and 4x SAS3/SATA3/NVMe storage drives	BPN-SAS3-826SEL1-N4	2
1U Passive CPU Heat Sink equipped with a Narrow Retention Mechanism	SNK-P0067PS	2
SAS3 mezzanine card for (SSG-6029P-E1CR24H only)	AOM-S3108M-H8L-P	1
Mezzanine card with LSI 3008 controller	AOM-S3008M-L8-P	1

1.2 Unpacking the System

Inspect the box the SuperStorage SSG-6029P-E1CR24H/L was shipped in and note if it was damaged in any way. If any equipment appears damaged, please file a damage claim with the carrier who delivered it.

Decide on a suitable location for the rack unit that will hold the server. It should be situated in a clean, dust-free area that is well ventilated. Avoid areas where heat, electrical noise and electromagnetic fields are generated. It will also require a grounded AC power outlet nearby. Be sure to read the precautions and considerations noted in Appendix B.

1.3 System Features

The following table provides you with an overview of the main features of the SSG-6029P-E1CR24H/L. Please refer to Appendix C for additional specifications.

System Features
Motherboard
X11DSC+
Chassis
SC826SE1C4-R1K62
CPU
The X11DSC+ serverboard supports dual Intel® Xeon® 81xx/61xx/51xx/41xx/31xx and 82xx/62xx/52xx/42xx/32xx series (Socket P) processors which offer three Intel® UltraPath Interconnect (UPI) of up to 10.4 GT/s. Note: Both CPUs need to be installed for full access to the PCI-E slots, DIMM slots, and onboard controllers. Refer to the block diagram on page 17 to determine which slots or devices may be affected.
Socket Type
Socket P
Memory
The integrated memory controller embedded in the processor supports up to 6 TB of 3DS Load Reduced DIMM (3DS LRDIMM), 3DS Registered NVDIMM and DIMM (3DS RDIMM) DDR4 (288-pin) ECC of up to 2933/2666 MHz modules in 24 slots.
Chipset
Intel PCH C621 chipset
Expansion Slots
Supports the following expansion slots: <ul style="list-style-type: none"> • One PCI-E 3.0 x16 SIOM networking slot supported by CPU1 • One PCI-E 3.0 x8+x8 SAS3 AOM slot for mezzanine card supported by CPU1 • One PCI-E 3.0 x8 slot supported by CPU2 (CPU2 Slot1) • Two PCI-E 3.0 x16 slots supported by CPU2 (CPU2 Slot2/CPU2 Slot3)
Hard Drives
Twenty-four 3.5" mid-chassis and two rear mounted hot-swap drive bays for SAS3/SATA4/NVMe drives
Cooling
Five 8-cm chassis fans
Power
1600 Watt redundant power supply
Form Factor
2U rackmount
Dimensions
(WxHxD) 17.2 x 3.5 x 30.7-in (437 x 89 x 780-mm)

1.4 Server Chassis Features

Control Panel

The switches and LEDs located on the control panel are described below. See Chapter 4 for details on the control panel connections.

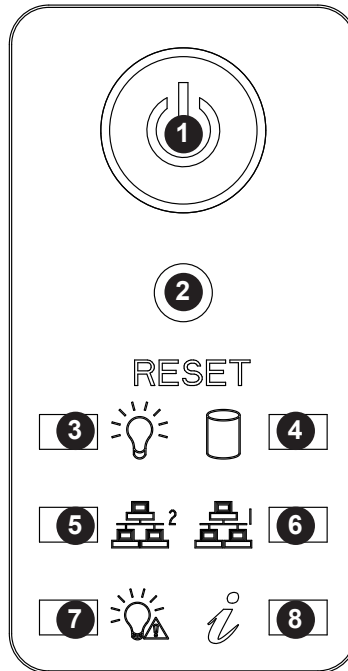

Figure 1-1. Control Panel View

Control Panel Features		
Item	Feature	Description
1	Power Button	The main power button is used to apply or remove power from the power supply to the server. Turning off system power with this button removes the main power but maintains standby power. To perform many maintenance tasks, you must also unplug system before servicing
2	Reset Button	The reset button is used to reboot the system
3	Power LED	Indicates power is being supplied to the system power supply. This LED should normally be illuminated when the system is operating.
4	HDD LED	Indicates activity on a hard drive when flashing.
5	NIC2 LED	Indicates network activity on LAN port 2 when flashing
6	NIC1 LED	Indicates network activity on LAN port 1 when flashing
7	Power Fail LED	Indicates a power supply module has failed.
8	Universal Information LED	See table below for details.

Information LED	
Status	Description
Continuously on and red	An overheat condition has occurred. (This may be caused by cable congestion.)
Blinking red (1Hz)	Fan failure, check for an inoperative fan.
Solid blue	UID has been activated locally to locate the server in a rack environment.
Blinking blue (300 msec)	UID has been activated using IPMI to locate the server in a rack environment.

Front Features

The SC826SE1C4-R1K62 is a 2U chassis. See the illustration below for the features included on the front of the chassis.

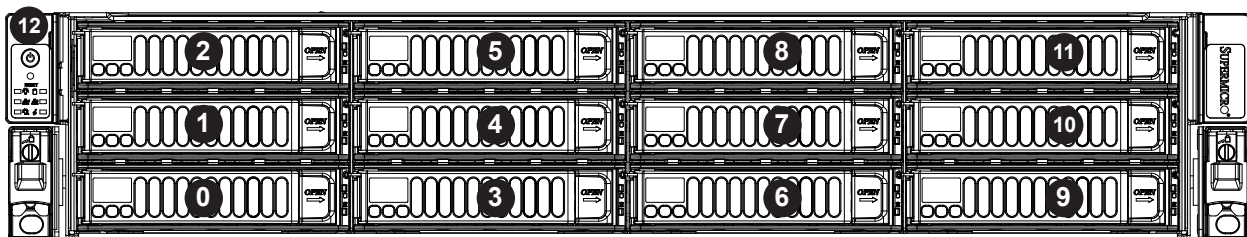

Figure 1-2. Chassis Front View

Front Chassis Features		
Item	Feature	Description
0-11	Hard Drive Carrier	Logical drive bay number for hot-swap hard drives
12	Control Panel	Control panel (see previous page for details)

Rear Features

The illustration below shows the features included on the rear of the chassis.

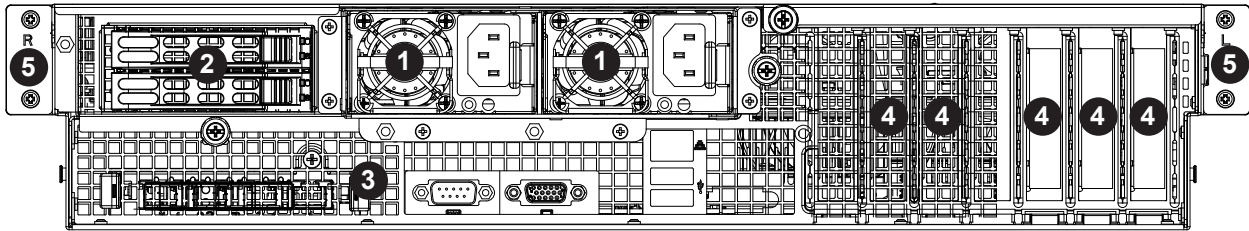

Figure 1-3. Chassis Rear View

Rear Chassis Features		
Item	Feature	Description
1	Power Supply Module	1600 Watt power supply (redundant, with two power modules)
2	3.5" Drive Bays	Two rear mounted 3.5" hot-swap drive bays
3	I/O Ports	I/O ports (see Section 4.3 for details)
4	PCI Slots	Five low-profile PCI slots for add-on cards
5	Rack Ear Brackets	Attaches server chassis to the rack

Quick Reference Table

Jumper	Description	Default Setting
JBT1	CMOS Clear	Open (Normal)
JPME2	Manufacturing Mode Select	Pins 1-2 (Normal)
JVRM_SEL1	VRM SMBus Clock (to BMC or PCH)	Pins 1-2 (BMC, Normal)
JWD1	Watch Dog Timer Enable	Pins 1-2 (Enabled, Reset)
Connector	Description	
COM1	Back panel COM port	
FAN1-5	System cooling fan headers	
IPMI_LAN	Dedicated IPMI LAN port	
I-SATA0-3	SATA 3.0 connection header supported by the Intel® PCH	
I-SATA2/I-SATA3	I-SATA Ports with built-in power pins and with support of Supermicro SuperDOM (Disk On Module) devices	
I-SGPIO1	Serial Link General Purpose I/O Header	
JBAT1	Onboard CMOS battery socket	
JF1	Front Control Panel header	
JI2C_EXP1/2	System Management Bus (SMBus) I2C for SAS3 backplanes	
JI2C_FP1	System Management Bus (SMBus) I2C for LCD devices	
JIPMB1	4-pin BMC External I ² C header (for an IPMI-supported card)	
JL1	Chassis Intrusion header	
(CPU1) JMEZZ1/JMEZZ2 PCI-E	PCI-Express 3.0 x8 Add-On-Module (AOM) slot from CPU1 for mezzanine card support (See the note below)	
JNVI ² C1/JNVI ² C2	NVMe SMBus (I ² C) headers used for PCI-E hot-plug SMBus clock & data connections (an SMCI-proprietary NVMe add-on card and cable are required; available for a Supermicro complete system only)	
JP ² C1	Power Supply SMBus I ² C header	
JPWR2/JPWR3	8-pin Power Supply connectors	
JPWR1	24-pin ATX main power supply connector	
JRK1	Intel® RAID Key header for NVMe SSD	
JSD1/JSD2	SATA DOM Power Connectors 1/2	
JSDCARD1	Micro SD Card Slot (reserved by manufacturer)	
JSEN1	Inlet Sensor Header	
JSTBY1	Standby power header	
JTPM1	Trusted Platform Module (TPM)/Port 80 connector	
P1_NVMe0-3	NVM Express PCI-E 3.0 x4 ports (ports 0-3) supported by CPU1	
(CPU1) SIOM PCI-E	PCI-Express 3.0 x16 slot from CPU1 for SMCI SIOM add-on module support	
(CPU2) SLOT1	PCI-Express 3.0 x8 Slots supported by CPU2	
(CPU2) SLOT2/SLOT3	PCI-Express 3.0 x16 Slot supported by CPU2	
SP1	Internal Speaker/Buzzer	
UID	Unit Identifier (UID) Switch	
USB0/1	Back panel USB 3.0 Ports	

Connector	Description
USB2	Type A USB 3.0 Header
VGA	VGA Port

LED	Description	Status
HDD_LED1	HDD LED	Green: On: HDD Normal
LEDBMC	BMC Heartbeat LED	Blinking Green: BMC normal
LEDPWR	Onboard Power LED	On: Onboard power on
UID-LED	UID (Unit Identifier) LED	Solid Blue: Unit identified

Memory LED	Description	Status
P1_LED_A1	CPU1_Memory_Fault_LED for DIMM A1	Red On: Memory Failure
P1_LED_A2	CPU1_Memory_Fault_LED for DIMM A2	Red On: Memory Failure
P1_LED_B1	CPU1_Memory_Fault_LED for DIMM B1	Red On: Memory Failure
P1_LED_B2	CPU1_Memory_Fault_LED for DIMM B2	Red On: Memory Failure
P1_LED_C1	CPU1_Memory_Fault_LED for DIMM C1	Red On: Memory Failure
P1_LED_C2	CPU1_Memory_Fault_LED for DIMM C2	Red On: Memory Failure
P1_LED_D1	CPU1_Memory_Fault_LED for DIMM D1	Red On: Memory Failure
P1_LED_D2	CPU1_Memory_Fault_LED for DIMM D2	Red On: Memory Failure
P1_LED_E1	CPU1_Memory_Fault_LED for DIMM E1	Red On: Memory Failure
P1_LED_E2	CPU1_Memory_Fault_LED for DIMM E2	Red On: Memory Failure
P1_LED_F1	CPU1_Memory_Fault_LED for DIMM F1	Red On: Memory Failure
P1_LED_F2	CPU1_Memory_Fault_LED for DIMM F2	Red On: Memory Failure
P2_LED_A1	CPU2_Memory_Fault_LED for DIMM A1	Red On: Memory Failure
P2_LED_A2	CPU2_Memory_Fault_LED for DIMM A2	Red On: Memory Failure
P2_LED_B1	CPU2_Memory_Fault_LED for DIMM B1	Red On: Memory Failure
P2_LED_B2	CPU2_Memory_Fault_LED for DIMM B2	Red On: Memory Failure
P2_LED_C1	CPU2_Memory_Fault_LED for DIMM C1	Red On: Memory Failure
P2_LED_C2	CPU2_Memory_Fault_LED for DIMM C2	Red On: Memory Failure
P2_LED_D1	CPU2_Memory_Fault_LED for DIMM D1	Red On: Memory Failure
P2_LED_D2	CPU2_Memory_Fault_LED for DIMM D2	Red On: Memory Failure
P2_LED_E1	CPU2_Memory_Fault_LED for DIMM E1	Red On: Memory Failure
P2_LED_E2	CPU2_Memory_Fault_LED for DIMM E2	Red On: Memory Failure
P2_LED_F1	CPU2_Memory_Fault_LED for DIMM F1	Red On: Memory Failure
P2_LED_F2	CPU2_Memory_Fault_LED for DIMM F2	Red On: Memory Failure

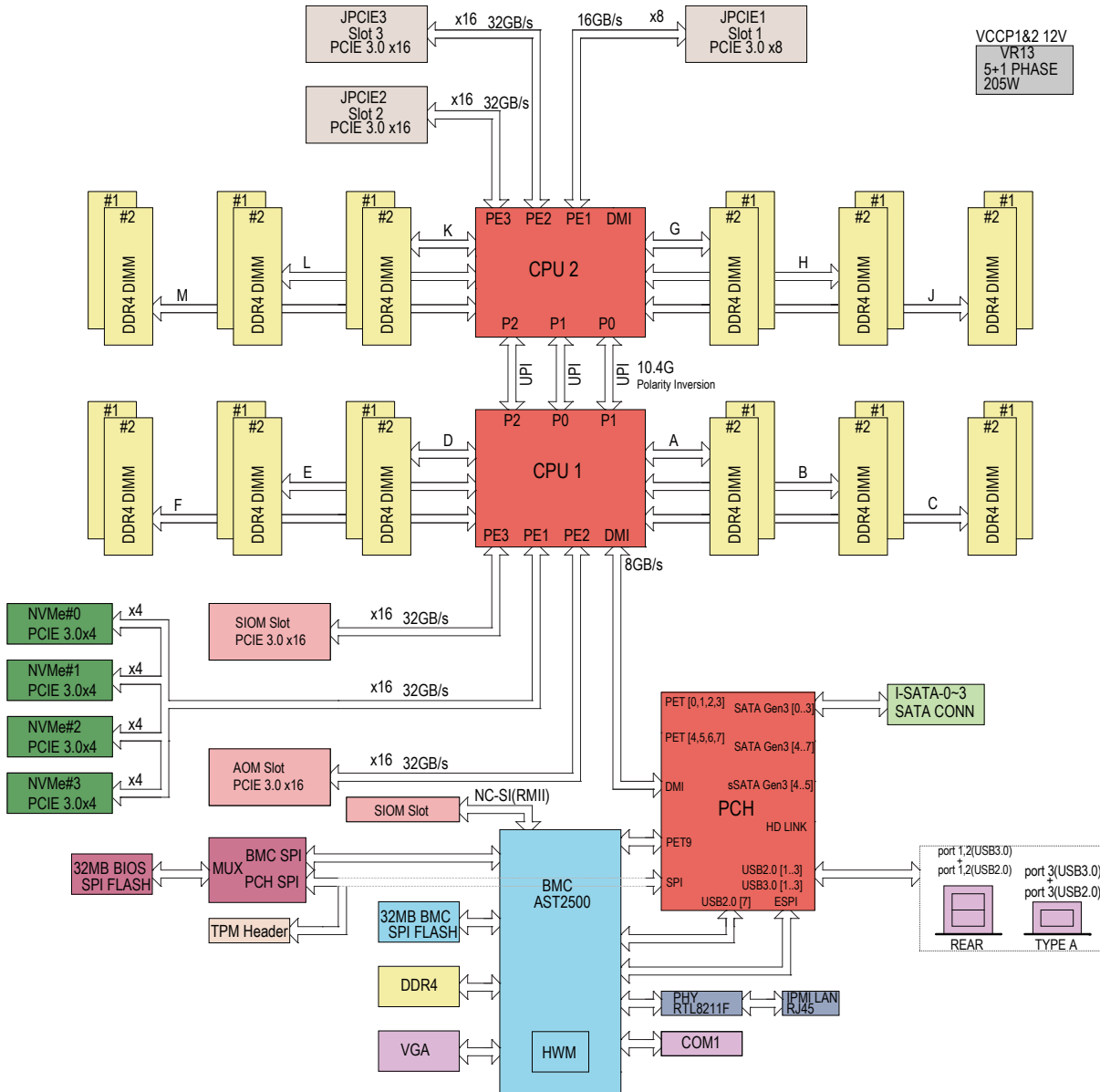

Figure 1-5. Intel PCH C621 Chipset: System Block Diagram

Note: This is a general block diagram and may not exactly represent the features on your motherboard. See the System Specifications appendix for the actual specifications of your motherboard.

Chapter 2

Server Installation

2.1 Overview

This chapter provides advice and instructions for mounting your system in a server rack. If your system is not already fully integrated with processors, system memory, etc., refer to Chapter 4 for details on installing those specific components.

Caution: Electrostatic Discharge (ESD) can damage electronic components. To prevent such damage to PCBs (printed circuit boards), it is important to use a grounded wrist strap, handle all PCBs by their edges, and keep them in anti-static bags when not in use.

2.2 Preparing for Setup

The box in which the system was shipped includes the rackmount hardware needed to install it into the rack. Please read this section in its entirety before you begin the installation.

Choosing a Setup Location

- The system should be situated in a clean, dust-free area that is well ventilated. Avoid areas where heat, electrical noise, and electromagnetic fields are generated.
- Leave enough clearance in front of the rack so that you can open the front door completely (~25 inches) and approximately 30 inches of clearance in the back of the rack to allow sufficient space for airflow and access when servicing.
- This product should be installed only in a Restricted Access Location (dedicated equipment rooms, service closets, etc.).
- This product is not suitable for use with visual display workplace devices according to §2 of the German Ordinance for Work with Visual Display Units.

Rack Precautions

- Ensure that the leveling jacks on the bottom of the rack are extended to the floor so that the full weight of the rack rests on them.
- In single rack installations, stabilizers should be attached to the rack. In multiple rack installations, the racks should be coupled together.
- Always make sure the rack is stable before extending a server or other component from the rack.
- You should extend only one server or component at a time; extending two or more simultaneously may cause the rack to become unstable.

Server Precautions

- Review the electrical and general safety precautions in Appendix B.
- Determine the placement of each component in the rack *before* you install the rails.
- Install the heaviest server components at the bottom of the rack first and then work your way up.
- Use a regulating uninterruptible power supply (UPS) to protect the server from power surges and voltage spikes and to keep your system operating in case of a power failure.
- Allow any drives and power supply modules to cool before touching them.
- When not servicing, always keep the front door of the rack and all covers/panels on the servers closed to maintain proper cooling.

Rack Mounting Considerations

Ambient Operating Temperature

If installed in a closed or multi-unit rack assembly, the ambient operating temperature of the rack environment may be greater than the room's ambient temperature. Therefore, consideration should be given to installing the equipment in an environment compatible with the manufacturer's maximum rated ambient temperature (TMRA).

Airflow

Equipment should be mounted into a rack so that the amount of airflow required for safe operation is not compromised.

Mechanical Loading

Equipment should be mounted into a rack so that a hazardous condition does not arise due to uneven mechanical loading.

Circuit Overloading

Consideration should be given to the connection of the equipment to the power supply circuitry and the effect that any possible overloading of circuits might have on overcurrent protection and power supply wiring. Appropriate consideration of equipment nameplate ratings should be used when addressing this concern.

Reliable Ground

A reliable ground must be maintained at all times. To ensure this, the rack itself should be grounded. Particular attention should be given to power supply connections other than the direct connections to the branch circuit (i.e. the use of power strips, etc.).



To prevent bodily injury when mounting or servicing this unit in a rack, you must take special precautions to ensure that the system remains stable. The following guidelines are provided to ensure your safety:

- This unit should be mounted at the bottom of the rack if it is the only unit in the rack.
- When mounting this unit in a partially filled rack, load the rack from the bottom to the top with the heaviest component at the bottom of the rack.
- If the rack is provided with stabilizing devices, install the stabilizers before mounting or servicing the unit in the rack.

2.3 Installing the System into a Rack

This section provides information on installing the SC826 chassis into a rack unit with the quick-release rails provided. There are a variety of rack units on the market, which may mean the assembly procedure will differ slightly. You should also refer to the installation instructions that came with the rack unit you are using.

Note: This rail will fit a rack between 26.5" and 36.4" deep.

Separating the Sections of the Rack Rails

The chassis package includes two rail assemblies in the rack mounting kit. Each assembly consists of three sections: An inner rail that secures directly to the chassis, an outer rail that secures to the rack, and a middle rail that slides in the outer rail. These assemblies are specifically designed for the left and right side of the chassis.



Slide rail mounted equipment is not to be used as a shelf or a work space.



Warning: Do not pick up the server with the front handles. They are designed to pull the system from a rack only.

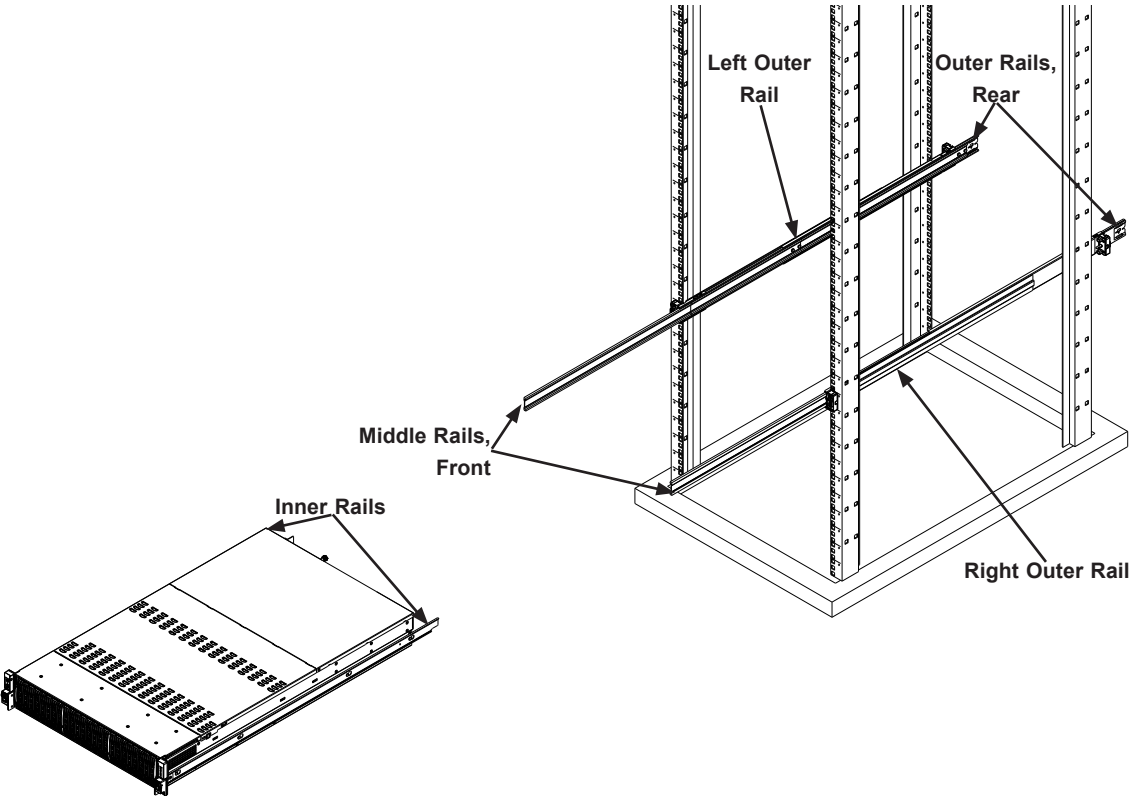

Figure 2-1. Identifying the Inner Rails, Middle Rails and Outer Rails

Note: Figures are for illustrative purposes only. Your actual chassis may differ. Always install servers into racks from the bottom up.

Releasing the Inner Rail

It is necessary to release the inner rail from the middle and outer rails before installing the inner rail on the chassis.

Releasing the Inner Rail from the Middle and Outer Rails

1. Lift the front latch on the inner rail and pull the inner rail out of the middle rail, and the middle rail out of the outer rail until the rails are fully extended.
2. Press down the locking lever on the inside of the inner rail to release the inner rail. Continue to pull the inner rail out of the middle rail.

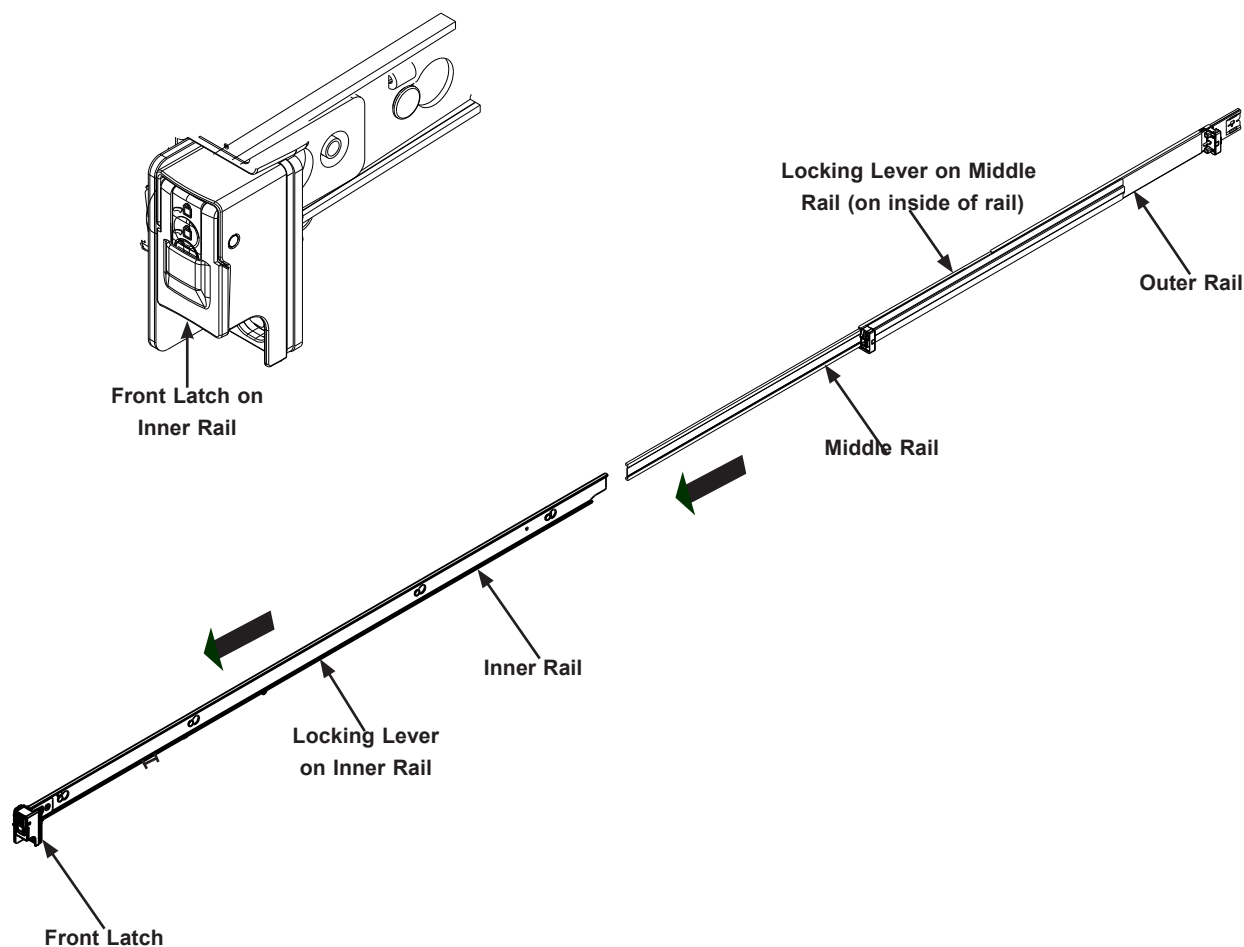

Figure 2-2. Extending the Rails and Releasing the Inner Rail



Warning: Stability hazard. The rack stabilizing mechanism must be in place, or the rack must be bolted to the floor before you slide the unit out for servicing. Failure to stabilize the rack can cause the rack to tip over.

Installing The Inner Rails on the Chassis

Installing the Inner Rails

1. Confirm that the left and right inner rails have been correctly identified.
2. Place the inner rail firmly against the side of the chassis, aligning the pins on the side of the chassis with the slotted thru holes in the inner rail.
3. Slide the inner rail toward the rear of the chassis until the pins are at the end of the narrow slot, which secures the inner rail to the chassis. An optional screw may be added for extra security.
4. Repeat for the other inner rail.

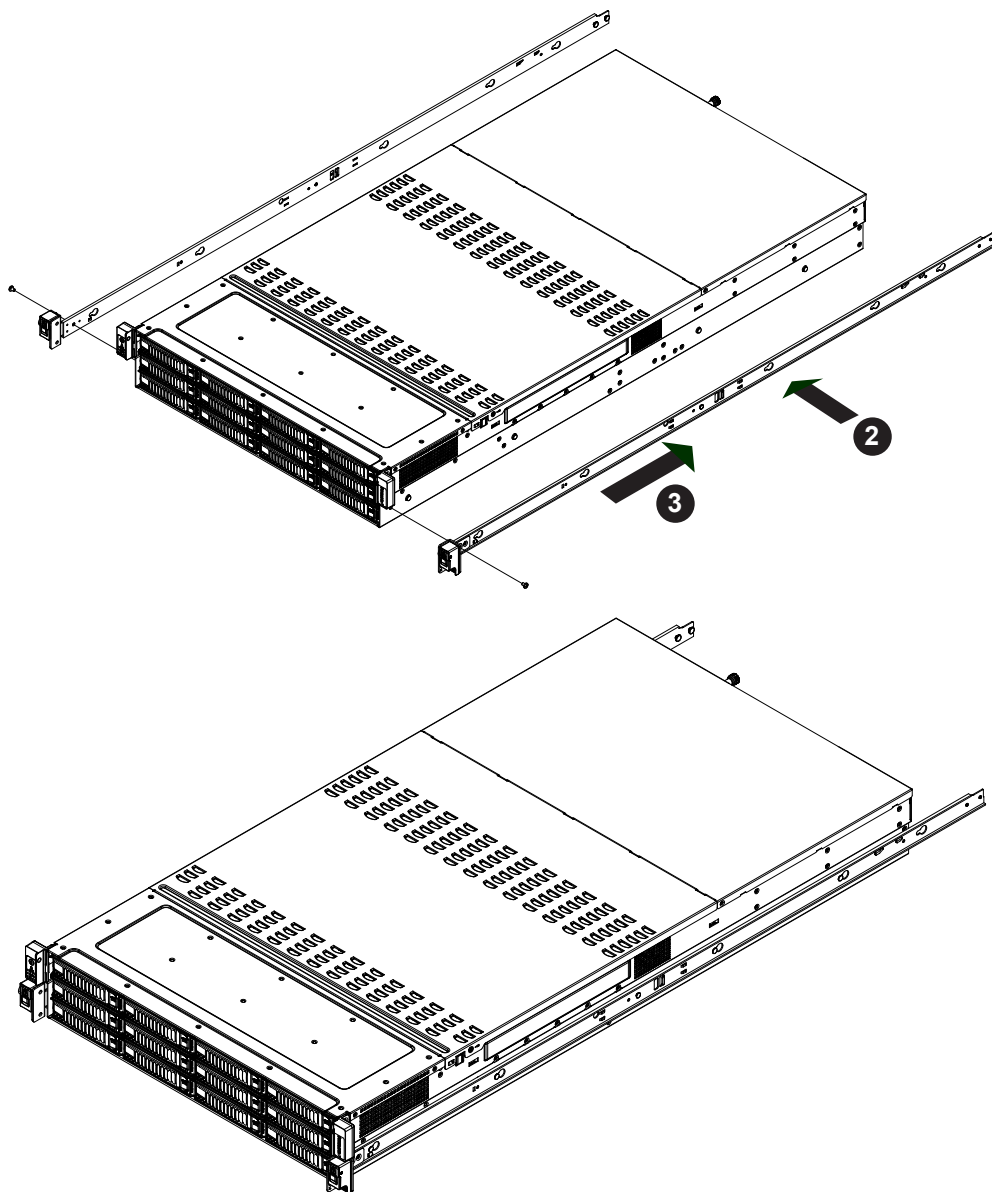

Figure 2-3. Installing the Inner Rails

Installing the Outer Rails on the Rack

Installing the Outer Rails

1. Confirm that the left and right outer rails have been correctly identified.
2. Release the small locking lever on the inside of the middle rail and push the middle rail back into the outer rail.
3. Insert the square pins at the front of the outer rail into the square holes on the front of the rack. Push until the latch snaps into place.
4. The outer rail is actually two pieces that slide to lengthen. Pull out the rear of the outer rail, adjusting the length until the square pin assembly passes, then fits against the back of the rear post. Be careful to keep the rail level.
5. Insert the square pins at the rear of the outer rail into the square holes on the rear of the rack. Push until the latch snaps into place.
6. Repeat for the other outer rail.

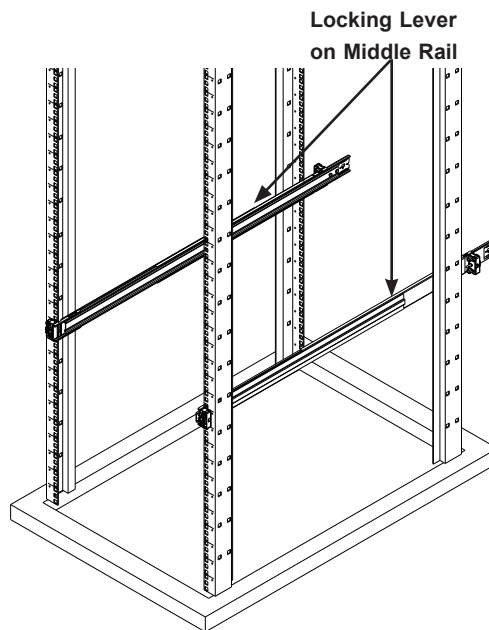

Figure 2-4. Installing the Outer Rails

Note: Figures are for illustrative purposes only. Your actual chassis may differ. Always install servers into racks from the bottom up.

Installing into the Rack

After the rails are installed on the chassis and on the rack, the server can be installed in the rack. It is heavy and requires two to three people to lift.

Installing the Chassis into a Rack

1. Pull both middle rails out the front of the outer rail until each clicks to a stop.
2. Align the inner rails on the chassis with the front of the middle rails.
3. Slide the inner rails on the chassis into the middle rails, keeping the pressure even on both sides. When partially in, the locking levers will stop further progress.
4. Press down the locking levers on the inside of the inner rails and push the chassis all the way into the rear of the rack. The front latches will click into place.

The server is now mounted in the rack. It can be pulled partially out for service by lifting both front latches.

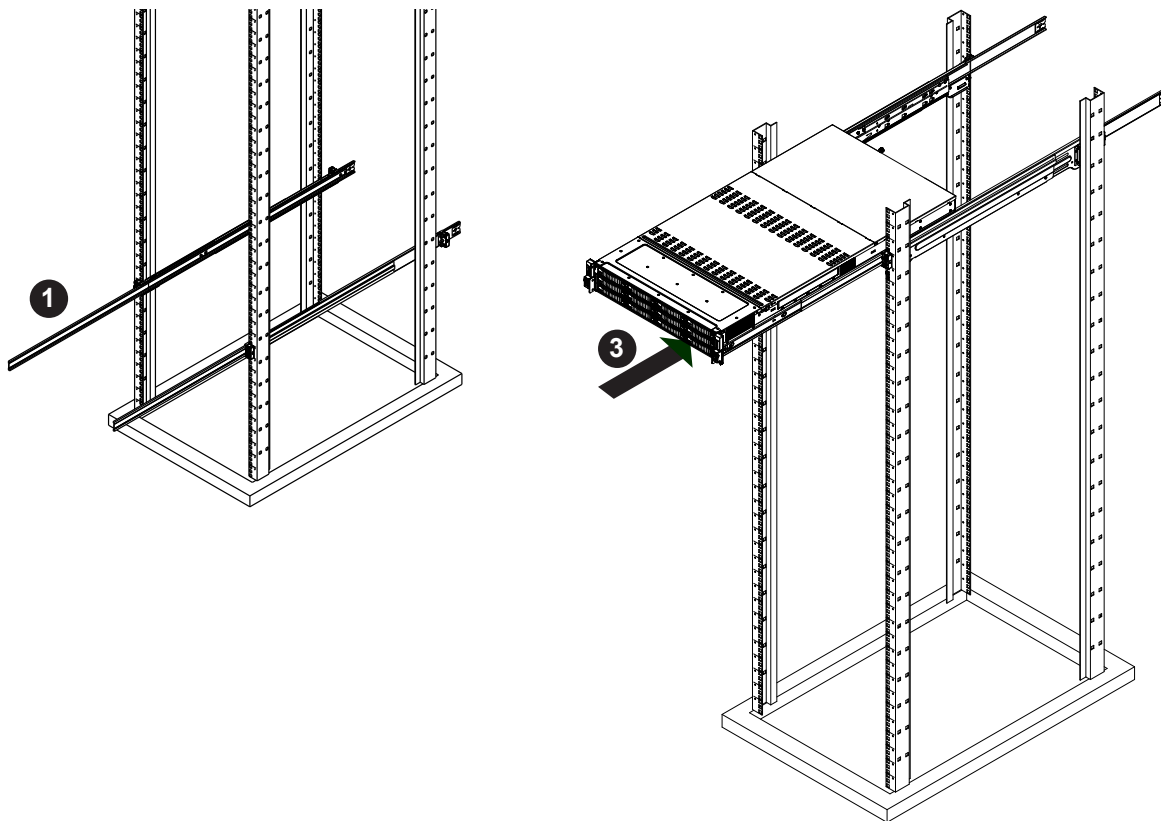

Figure 2-5. Installing the Chassis into the Rack

Note: Figures are for illustrative purposes only. Your actual chassis may differ. Always install servers into racks from the bottom up.

Removing the Chassis From the Rack

Caution: The server is heavy and requires two to three people to lift it out.

Removing the Chassis

1. Lift the right and left front latches which are just below the LED control panels on the front edges of the chassis.
2. Pull the chassis forward until it clicks to a stop.
3. Press down the locking lever on the inside of the inner rail (Figure 2-2) to release the server. Continue to pull the server out of the middle rails.

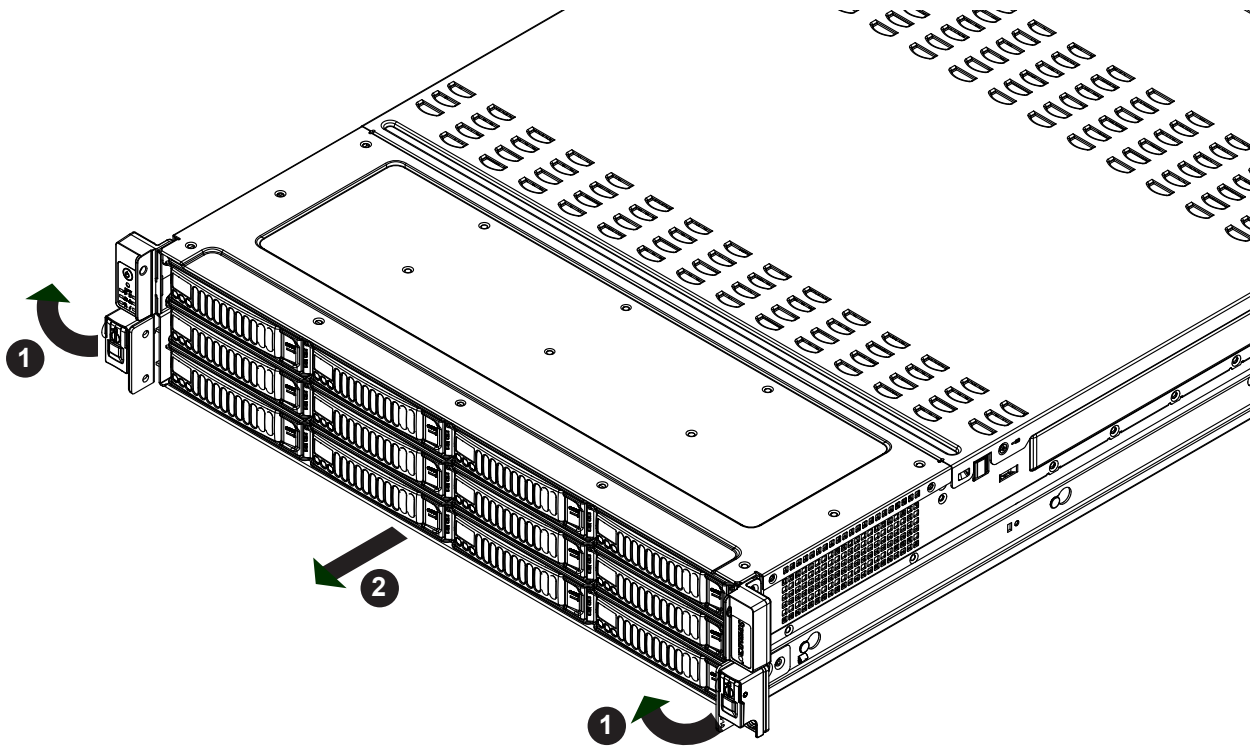

Figure 2-6. Removing the Chassis from the Rack

Removing the Outer Rails From the Rack

In the uncommon event that it is necessary to remove the outer rails from the rack, follow these instructions. The chassis must be out of the rack.

Releasing the Outer Rails

1. On the front of the outer rail, slide the small plastic safety slider (red in drawing) up and hold it while pushing the plastic release button (green in drawing) just below it.
2. While holding the release button in, pull the outer rail forward to disengage the pins and the front of the rail from the rack.
3. Support the front of the outer and middle rail assembly while releasing the rear.
4. Remove the outer rail from the rear of the rack in the same way as the front. Slide the safety slider up and push and hold the release button, then pull the rear pins out of the rack and remove the rail.

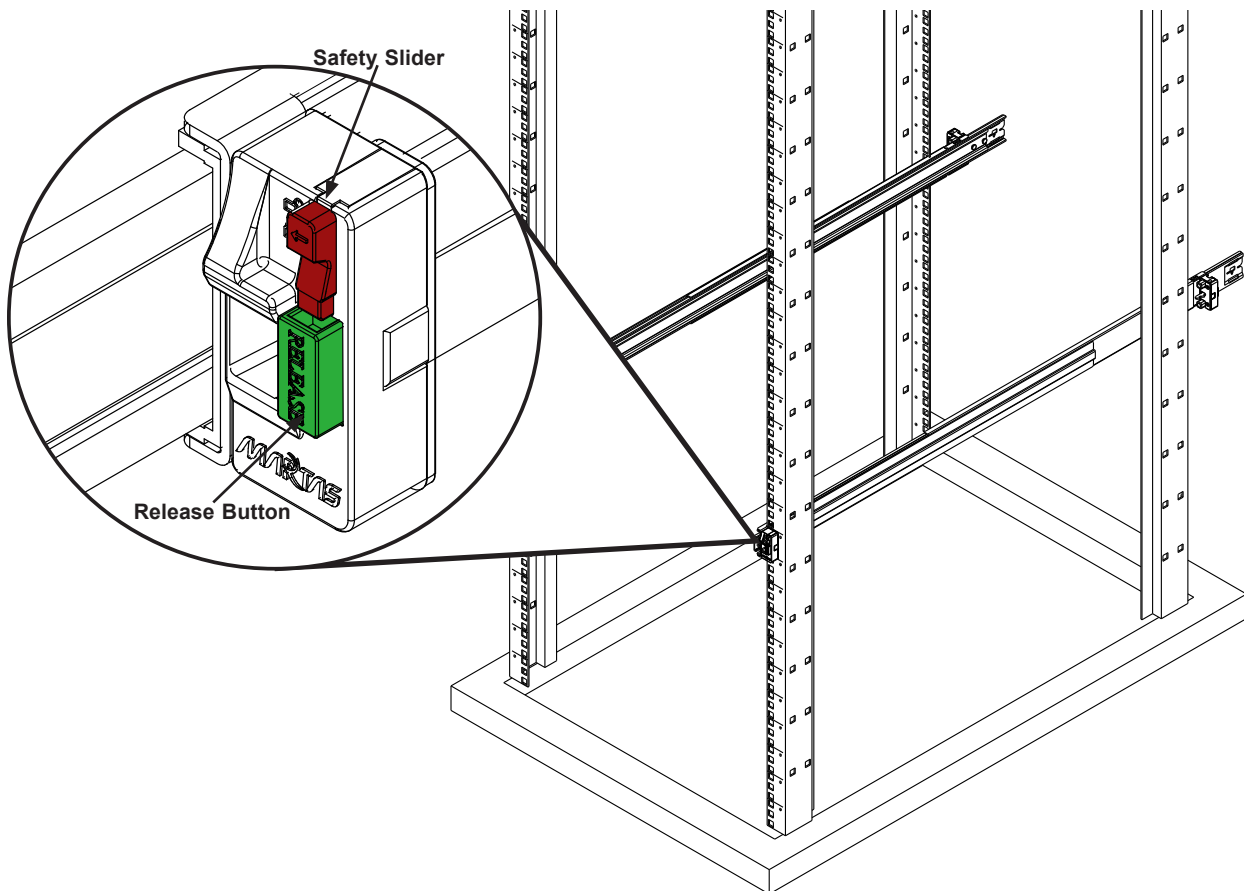

Figure 2-7. Removing the Outer Rails

2.4 Installing the Cable Management Arm

The SC826 chassis supports a cable management arm (CMA) that allows servicing while the server is running. The CMA keeps the rear cables organized and clear of the rail mechanisms when the system is extended out the front of the rack. The kit includes six fabric Velcro cable ties.

WCMA W1428 is packed with one full piece of cable management arm, six Velcro straps and user menu.

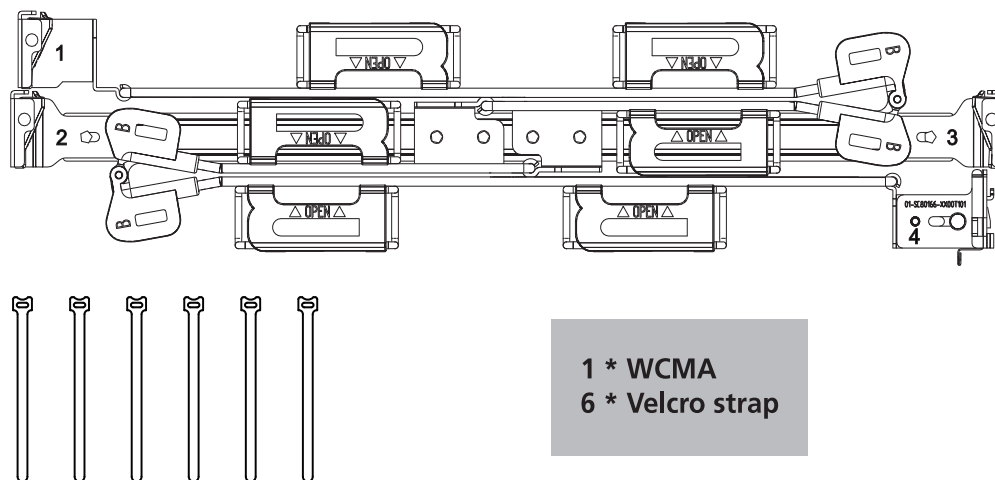

Figure 2-8. Cable Management Arm and Velcro Straps

The CMA attaches to the rack mounting rails by means of four connectors. They are labeled on the connectors 1, 2, 3, and 4.

Installing the Cable Management Arm

1. Slide CMA connector #1 forward onto the two posts on the rear of the right inner rail (right side when viewed from the front). It snaps into place.
2. Slide CMA connector #2 forward onto the two posts on the rear of the right middle rail. It snaps into place.

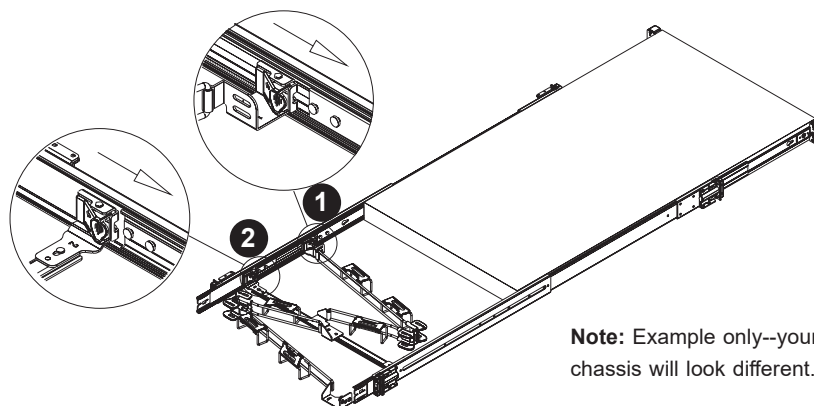

Figure 2-9. Installing the Connectors 1 and 2

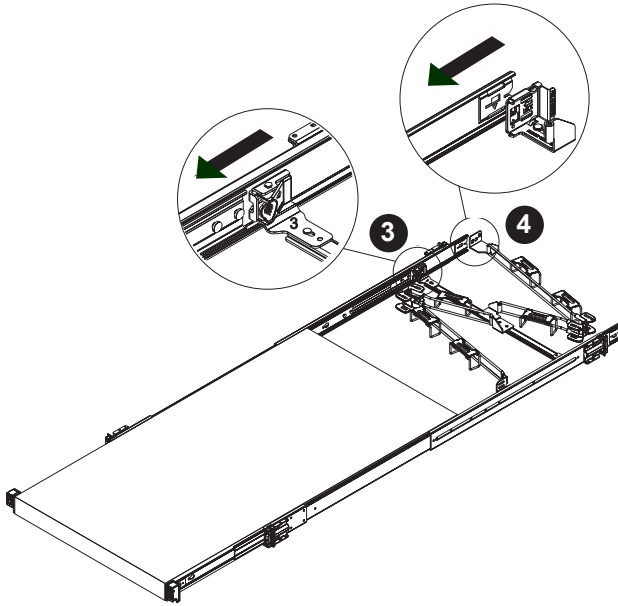

Figure 2-10. Installing the Connectors 3 and 4

3. Slide CMA connector #3 forward onto the two posts on the rear of the left middle rail. It snaps into place.
4. For CMA connector #4, align the metal tabs with the slots on the rear of the left outer rail and push it forward. It snaps into place.

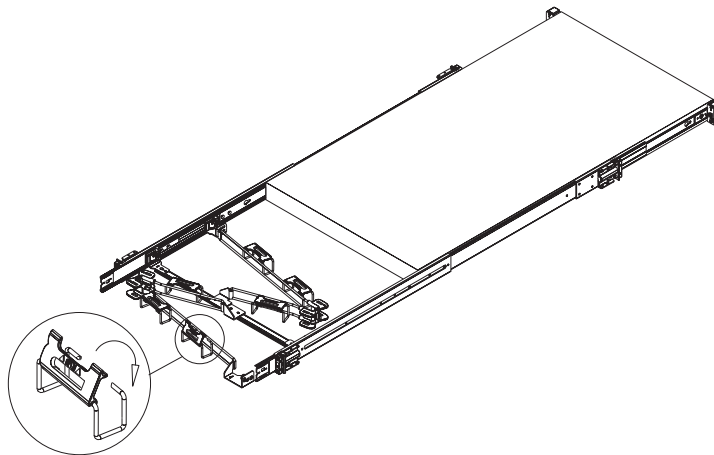

Figure 2-11. Routing the Cables

5. Open the six red plastic caps and route the cables into the wire carrier.
6. Use the six Velcro straps to secure the cables to the CMA. Use a strap on either side of each joint and one on each connector.
7. Slide the chassis forward and backward in the rack to confirm that the cable management arm is operating smoothly.

If at some time you must remove the cable management arm, follow the below procedure.

Removing the Cable Management Arm

1. Remove cables from the CMA, releasing the Velcro straps and the red plastic caps.
2. For CMA connector #4, pull the metal release tab toward the center of the rack and slide the connector toward the rear to release it.
3. For CMA connectors #3, #2, and #1, depress the front edge of the yellow plastic rocker lock, and slide the connector toward the rear to release it.

Chapter 3

Maintenance and Component Installation

This chapter provides instructions on installing and replacing main system components. To prevent compatibility issues, only use components that match the specifications and/or part numbers given.

Installation or replacement of most components require that power first be removed from the system. Please follow the procedures given in each section.

3.1 Removing Power

Use the following procedure to ensure that power has been removed from the system. This step is necessary when removing or installing non hot-swap components or when replacing a non-redundant power supply.

1. Use the operating system to power down the system.
2. After the system has completely shut-down, disconnect the AC power cord(s) from the power strip or outlet. (If your system has more than one power supply, remove the AC power cords from all power supply modules.)
3. Disconnect the power cord(s) from the power supply module(s).

3.2 Accessing the System

Removing the Top Covers

Mid-chassis Cover

The mid-chassis cover can be removed to access the mid-chassis drives or fans while the server continues to operate.

Removing the Mid-chassis Cover

Remove the two screws securing each side of the cover, push in the release buttons, then lift the cover.

Warning: Except for short periods of time, do not operate the server without the cover in place. The chassis cover must be in place to allow for proper airflow and to prevent overheating.

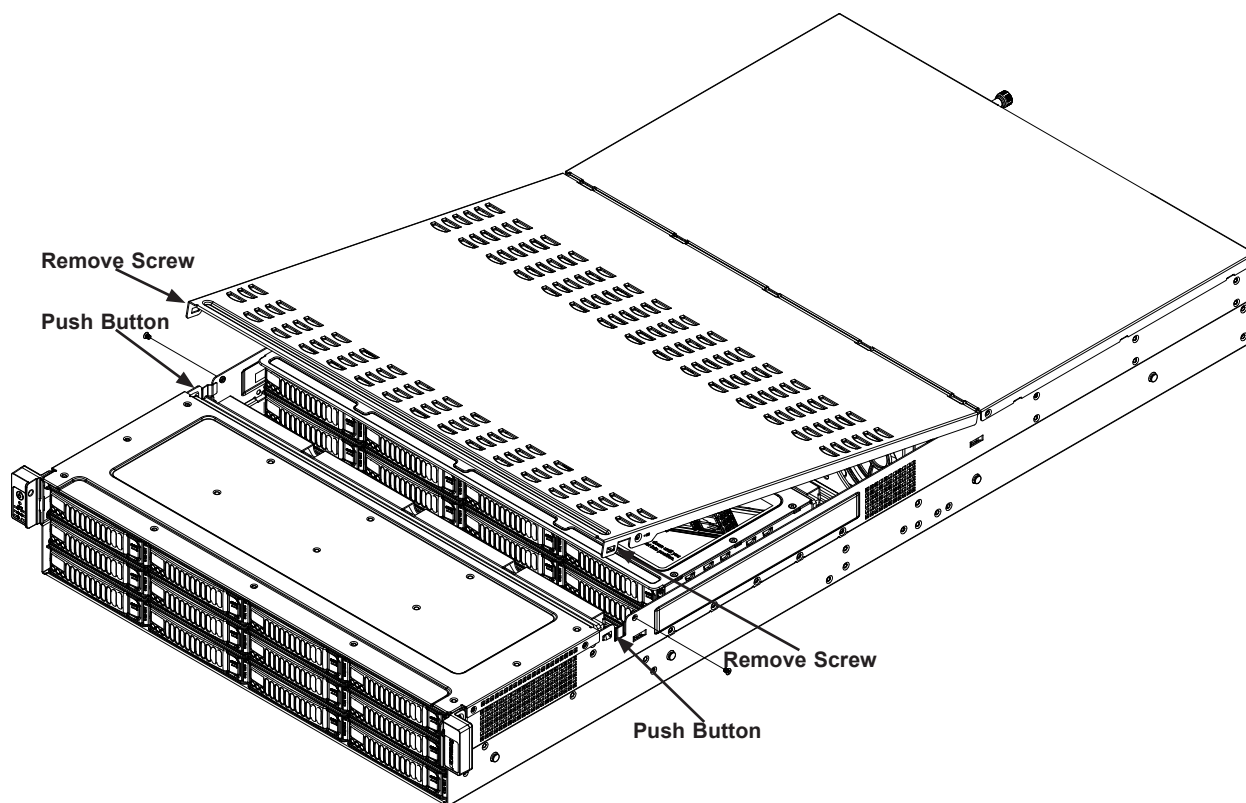

Figure 3-1. Removing the Mid-chassis Cover

Rear Cover

Removing the Rear Cover

Remove the two screws on the side of the chassis and the thumbscrew at the rear of the chassis, then slide the cover to the rear and off.

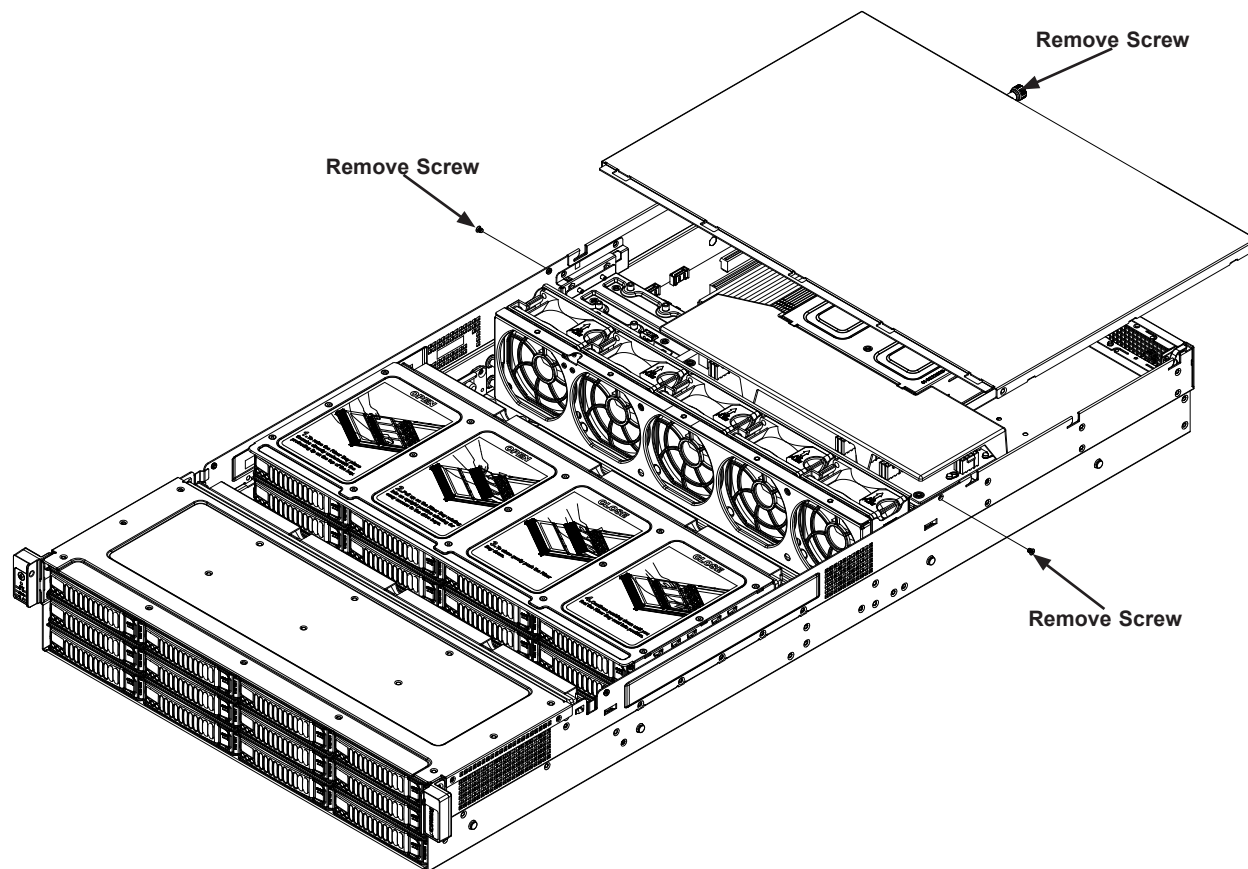

Figure 3-2. Removing the Rear Cover

3.3 Motherboard Components

Processor and Heatsink Installation

The processor (CPU) and heatsink should be assembled together first to form the processor heatsink module (PHM), and then install the PHM into the CPU socket.

Caution: Use ESD protection. Do not touch the underside of the CPU. Improper installation or socket misalignment can cause serious damage to the CPU or socket which may require manufacturer repairs.

Notes:

- All power should be off, as described in Section 3.1, before installing the processors.
- When handling the processor package, avoid placing direct pressure on the label area of the CPU or socket.
- Check that the plastic socket dust cover is in place and none of the socket pins are bent—otherwise, contact your retailer.
- Refer to the Supermicro website for updates on CPU support.
- Graphics in this manual are for illustration. Your components may look slightly different.

The Intel® Xeon® 81xx/61xx/51xx/41xx/31xx and 82xx/62xx/52xx/42xx/32xx series Series Processors

Note: The Intel® Xeon® 81xx/61xx/51xx/41xx/31xx and 82xx/62xx/52xx/42xx/32xx series processors contain two models - the F model processors and the Non-F model processors. This motherboard supports the Non-F model processors only.

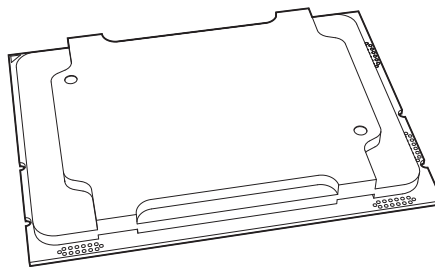

Intel® Processor (Non-F Model)

Note: All graphics, drawings, and pictures shown in this manual are for illustration only. The components that came with your machine may or may not look exactly the same as those shown in this manual.

Overview of the Processor Socket Assembly

The processor socket assembly contains 1) the Intel® Xeon® 81xx/61xx/51xx/41xx/31xx and 82xx/62xx/52xx/42xx/32xx series processor, 2) the narrow processor clip, 3) the dust cover, and 4) the CPU socket.

1. The Intel® Xeon® 81xx/61xx/51xx/41xx/31xx and 82xx/62xx/52xx/42xx/32xx series Processor

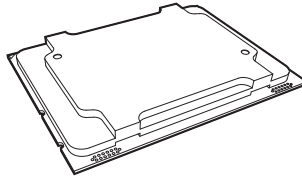

(The Intel® Xeon® 81xx/61xx/51xx/41xx/31xx and 82xx/62xx/52xx/42xx/32xx series Processor)

2. Narrow processor clip (the plastic processor package carrier used for the CPU)

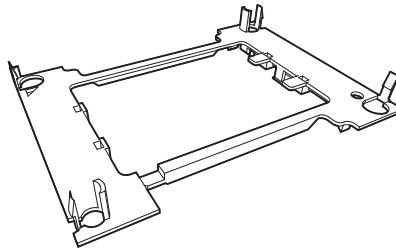

(for the non-F Model)

3. Dust Cover

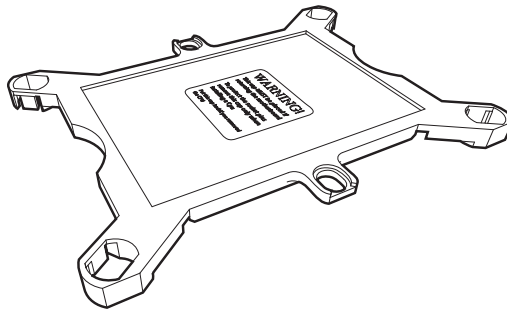

4. CPU Socket

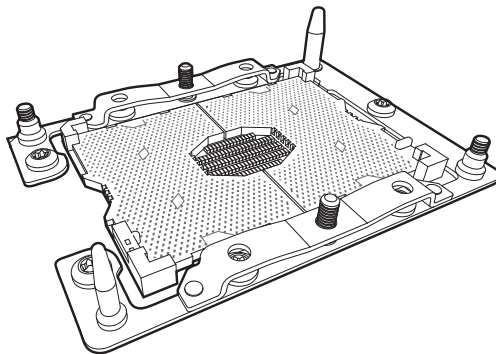

Note: Be sure to cover the CPU socket with the dust cover when the CPU is not installed.

Overview of the Processor Heatsink Module (PHM)

The Processor Heatsink Module (PHM) contains 1) a heatsink, 2) a narrow processor clip, and 3) the Intel® Xeon® 81xx/61xx/51xx/41xx/31xx and 82xx/62xx/52xx/42xx/32xx series processor.

1. Heatsink

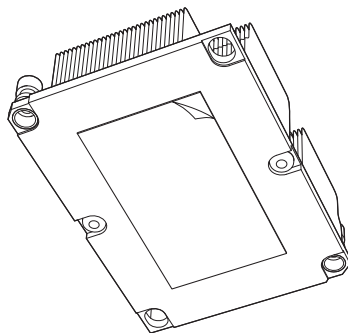

2. Narrow processor clip

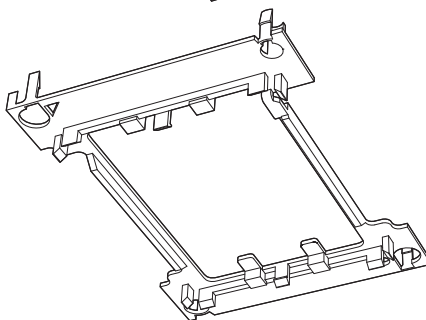

3. Intel® Processor

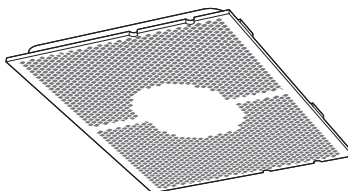

Processor Heatsink Module (PHM)

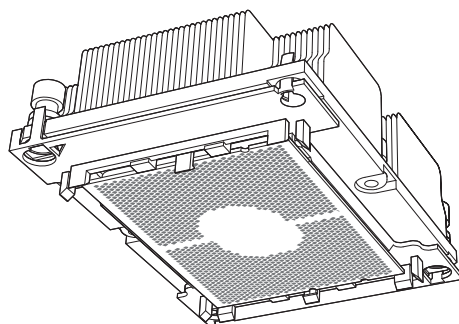

(Bottom View for the non-F Model)

Assembling the Processor Package

Attach the processor to the thin processor clip to create the processor package.

1. On the top corner of the CPU, locate pin 1 (A), marked by a triangle. Also, locate notch B and notch C (and notch D for F models) on the CPU as shown below.
2. On the top of the processor clip, locate the corner marked by a hollow triangle as the position for pin 1. Also locate notch B and notch C (and D for F models) on the processor clip.
3. Align pin 1 of the CPU with its proper position on the processor clip and carefully insert the CPU into the processor clip. Slide notch B of the CPU into tab B of the processor clip, and slide notch C of the CPU into tab C of the processor clip (and D for F models) until the processor clip tabs snap onto the CPU.
4. Examine all corners to ensure that the CPU is properly seated and secure on the processor clip.

The processor package assembly is created.

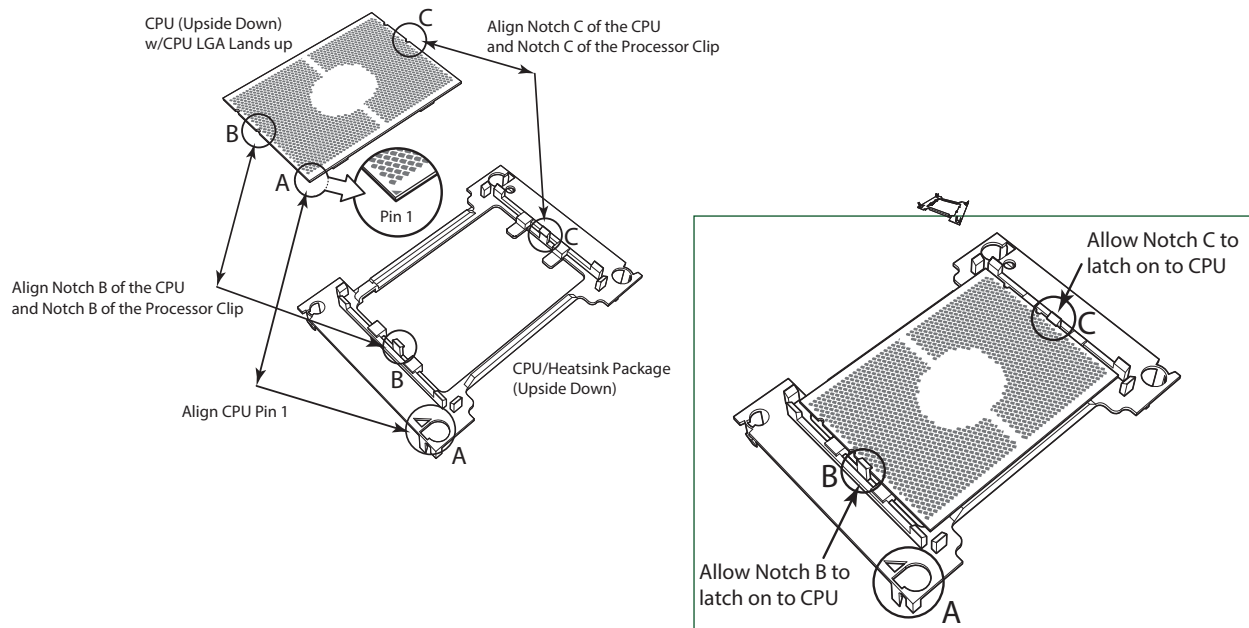

Processor Package Assembly for the non-F Model Processors

Installing the Processor Heatsink Module (PHM)

1. Locate the triangle (pin 1) on the CPU socket. Also locate the pin 1 corner of the PHM that is closest to "1" on the heatsink label. To confirm, look at the underside of the PHM and note the hollow triangle in the processor clip and printed triangle on the CPU located next to a screw at the corner.
2. Align the pin 1 corner of the PHM over the pin 1 corner on the CPU socket.
3. Align the two holes at diagonal corners of the PHM onto the two guide posts on the socket bracket and carefully lower the PHM onto the socket.
4. Use a T30 Torx-bit screwdriver to install four screws into the mounting holes on the socket to securely attach the PHM onto the motherboard in the sequence of 1, 2, 3, and 4, as marked on the heatsink label. Gradually tighten each to assure even pressure.

Note: Use only 12 foot-pounds of torque when tightening the screws to avoid damaging the processor or the socket.

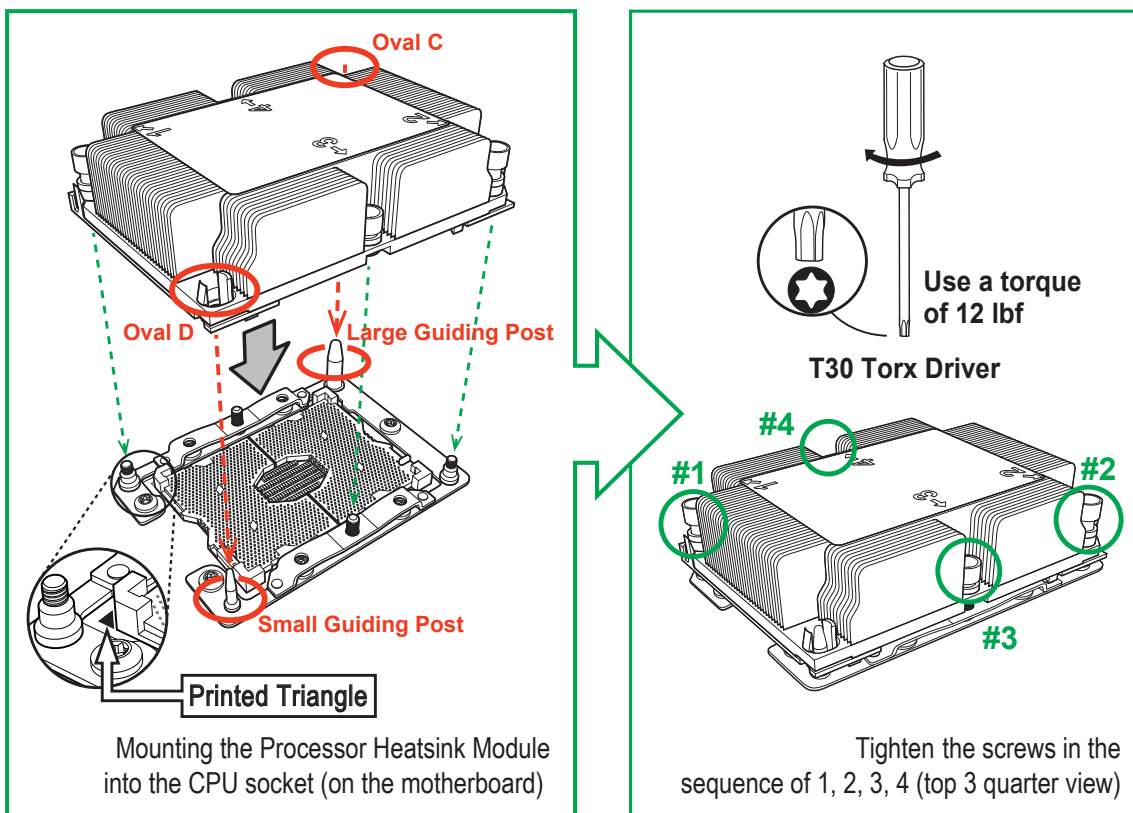

Installing the Processor Heatsink Module

Removing the Processor Heatsink Module from the Motherboard

Before removing the processor heatsink module (PHM), power down as described in Section 3.1.

1. Using a T30 Torx-bit screwdriver, loosen and remove the screws on the PHM from the socket, starting with the screw marked #4, in the sequence of 4, 3, 2, 1.
2. Pull up the PHM while releasing the small snap tabs on two corners of the socket.

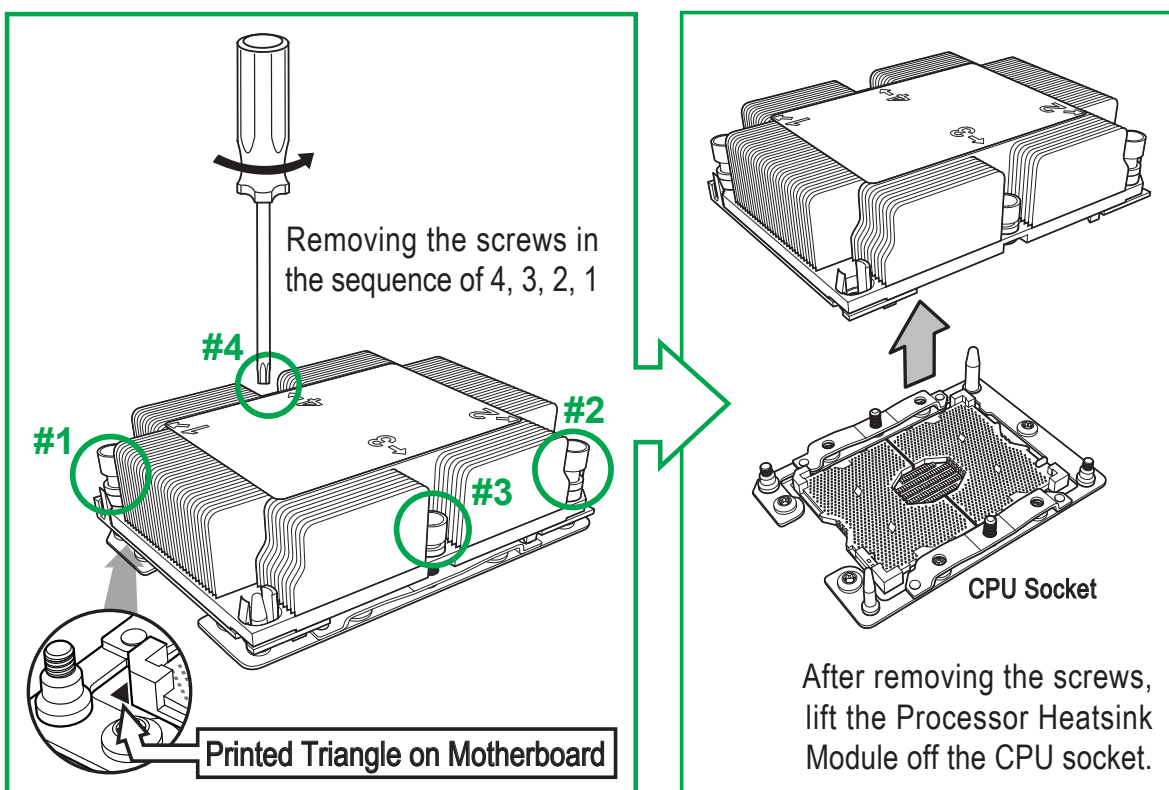

Removing the Processor Heatsink Module

Memory Support and Installation

Note: Check the Supermicro website for recommended memory modules.

Important: Exercise extreme care when installing or removing DIMM modules to prevent any damage.

ESD Precautions

Electrostatic Discharge (ESD) can damage electronic components including memory modules. To avoid damaging your DIMM modules, it is important to handle it very carefully. The following measures are generally sufficient to protect your equipment from ESD.

Precautions

- Use a grounded wrist strap designed to prevent static discharge.
- Handle the memory module by its edges only.
- Put the memory modules into the antistatic bags when not in use.
- Check the Supermicro website for recommended memory modules

Introduction to Intel® Optane DC Persistent Memory

Intel® 82xx/62xx/52xx/4215 supports new DCPMM (Optane™ DC Persistent Memory Modules) technology. DCPMM offers data persistence with higher capacity at lower latencies than the existing memory modules and provides hyper-speed storage capability for high performance computing platforms with flexible configuration options.

Memory Support

The integrated memory controller embedded in the processor supports up to 6 TB of 3DS Load Reduced DIMM (3DS LRDIMM), 3DS Registered NVDIMM and DIMM (3DS RDIMM) DDR4 (288-pin) ECC of up to 2933/2666 MHz modules in 24 slots. Populating the DIMM slots in a 2DPC (two DIMMs per channel) configuration with pairs of memory modules of the same type, speed and size will result in interleaved memory, which improves performance.

Note: 2933 MHz memory is supported by the 82xx/62xx series processors only.

DIMM Installation

1. Follow the instructions given in the memory population guidelines listed in the previous sections to install memory modules on your motherboard. For the system to work properly, please use memory modules of the same type and speed on the motherboard. (See the Note below.)
2. Push the release tabs outwards on both ends of the DIMM slot to unlock it.
3. Align the key of the DIMM module with the receptive point on the memory slot.
4. Align the notches on both ends of the module against the receptive points on the ends of the slot.
5. Use two thumbs together to press the DIMM module straight down into the slot until the module snaps into place.
6. Press the release tabs to the lock positions to secure the DIMM module into the slot.

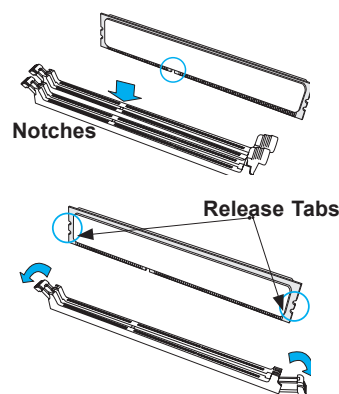
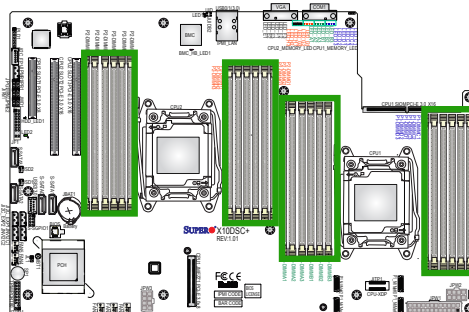

Insert the DIMM module into the memory slot.

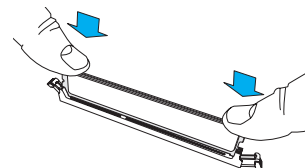

DIMM Module Removal

Press the release tabs on both ends of the DIMM socket to release the DIMM module from the socket as shown in the drawing on the right.

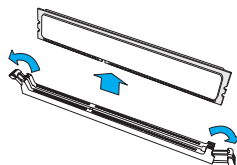

Warning! 1. To avoid damage to the DIMM module or the DIMM socket, do not use excessive force when pressing the release tabs on the ends of the DIMM socket. **2.** Handle DIMM modules with care. Carefully follow all the instructions given in Section 1 of this user guide to avoid ESD-related damage to your components or system. **3.** All graphics, including the layout drawing above, are for reference only. Your system components may or may not look the same as shown in this user guide.

DDR4 Memory Support for 81xx/61xx/51xx/41xx/31xx Processors						
Type	Ranks Per DIMM and Data Width	DIMM Capacity (GB)		Speed (MT/s)		
				One Slot per Channel	Two Slots per Channel	
		DRAM Density		One DIMM per Channel	One DIMM per Channel	Two DIMMs per Channel
		4 Gb	8 Gb	1.2 Volts	1.2 Volts	1.2 Volts
RDIMM	SRx4	4 GB	8 GB	2666	2666	2666
	SRx8	8 GB	16 GB			
	DRx8	8 GB	16 GB			
	DRx4	16 GB	32 GB			
RDIMM 3Ds	QRX4	N/A	2H-64GB			
	8RX4	N/A	4H-128GB			
LRDIMM	QRx4	32 GB	64 GB			
LRDIMM 3Ds	QRx4	N/A	2H-64GB			
	8Rx4	N/A	4H-128 GB			

DDR4 Memory Support for 82xx/62xx/52xx/42xx/32xx Processors							
Type	Ranks Per DIMM and Data Width	DIMM Capacity (GB)			Speed (MT/s)		
					One Slot per Channel	Two Slots per Channel	
		DRAM Density			One DIMM per Channel	One DIMM per Channel	Two DIMMs per Channel
		4 Gb	8 Gb	16 Gb	1.2 Volts	1.2 Volts	1.2 Volts
RDIMM	SRx4	4 GB	8 GB	16 GB	2933	2933	2933
	SRx8	8 GB	16 GB	32 GB			
	DRx8	8 GB	16 GB	32 GB			
	DRx4	16 GB	32 GB	64 GB			
RDIMM 3Ds	QRX4	N/A	2H-64GB	2H-128GB			
	8RX4	N/A	4H-128GB	4H-256GB			
LRDIMM	QRx4	32 GB	64 GB	128 GB			
LRDIMM 3Ds	QRx4	N/A	2H-64GB	2H-64GB			
	8Rx4	N/A	4H-128 GB	4H-256 GB			

Memory Installation Sequence

Memory modules for the X11 UP/DP/MP motherboards are populated using the "Fill First" method. The blue memory slot of each channel is considered the "first DIMM module" of the channel, and the black slot, the second module of the channel. When installing memory modules, be sure to populate the blue memory slots first and then populate the black slots. To maximize memory capacity and performance, please populate all DIMM slots on the motherboard, including all blue slots and black slots.

General Memory Population Requirements

1. Be sure to use the memory modules of the same type and speed on the motherboard. Mixing of memory modules of different types and speeds is not allowed.
2. Using unbalanced memory topology such as populating two DIMMs in one channel while populating one DIMM in another channel on the same motherboard will result in reduced memory performance.
3. Populating memory slots with a pair of DIMM modules of the same type and size will result in interleaved memory, which will improve memory performance.

DIMM Population Guidelines for Optimal Performance

For optimal memory performance, follow the instructions listed in the tables below when populating memory modules.

Key Parameters for DIMM Configuration

Key Parameters for DIMM Configurations	
Parameters	Possible Values
Number of Channels	1, 2, 3, 4, 5, or 6
Number of DIMMs per Channel	1DPC (1 DIMM Per Channel) or 2DPC (2 DIMMs Per Channel)
DIMM Type	RDIMM (w/ECC), 3DS RDIMM, LRDIMM, 3DS LRDIMM
DIMM Construction	non-3DS RDIMM Raw Cards: A/B (2Rx4), C (1Rx4), D (1Rx8), E (2Rx8) 3DS RDIMM Raw Cards: A/B (4Rx4) non-3DS LRDIMM Raw Cards: D/E (4Rx4) 3DS LRDIMM Raw Cards: A/B (8Rx4)

DIMM Mixing Guidelines

General DIMM Mixing Guidelines
<ul style="list-style-type: none"> • All DIMMs must be all DDR4 DIMMs. • x4 and x8 DIMMs can be mixed in the same channel. • Mixing of LRDIMMs and RDIMMs is not allowed in the same channel, across different channels, and across different sockets. • Mixing of non-3DS and 3DS LRDIMM is not allowed in the same channel, across different channels, and across different sockets.

Mixing of DIMM Types within a Channel			
DIMM Types	RDIMM	LRDIMM	3DS LRDIMM
RDIMM	Allowed	Not Allowed	Not Allowed
LRDIMM	Not Allowed	Allowed	Not Allowed
3DS LRDIMM	Not Allowed	Not Allowed	Allowed

Note: Unbalanced memory configuration decreases memory performance and is not recommended for Supermicro motherboards.

Memory Population Table for the X11DP Motherboard w/24 DIMM Slots Onboard	
CPUs/DIMMs	Memory Population Sequence
1 CPU & 1 DIMM	CPU1: P1-DIMMA1
1 CPU & 2 DIMMs	CPU1: P1-DIMMA1/P1-DIMMD1
1 CPU & 3 DIMMs	CPU1: P1-DIMMC1/P1-DIMMB1/P1-DIMMA1
1 CPU & 4 DIMMs	CPU1: P1-DIMMB1/P1-DIMMA1/P1-DIMMD1/P1-DIMME1
1 CPU & 5 DIMMs*	CPU1: P1-DIMMC1/P1-DIMMB1/P1-DIMMA1/P1-DIMMD1/P1-DIMME1
1 CPU & 6 DIMM	CPU1: P1-DIMMC1/P1-DIMMB1/P1-DIMMA1/P1-DIMMD1/P1-DIMME1/P1-DIMMF1
1 CPU & 7 DIMMs*	CPU1: P1-DIMMB1/P1-DIMMB2/P1-DIMMA1/P1-DIMMA2/P1-DIMMD1/P1-DIMME1/P1-DIMMF1
1 CPU & 8 DIMMs	CPU1: P1-DIMMB1/P1-DIMMB2/P1-DIMMA1/P1-DIMMA2/P1-DIMMD2/P1-DIMMD1/P1-DIMME2/P1-DIMME1
1 CPU & 9 DIMMs*	CPU1: P1-DIMMC1/P1-DIMMC2/P1-DIMMB1/P1-DIMMB2/P1-DIMMA1/P1-DIMMA2/P1-DIMMD1/P1-DIMME1/P1-DIMMF1
1 CPU & 10 DIMMs*	CPU1: P1-DIMMC1/P1-DIMMB1/P1-DIMMB2/P1-DIMMA1/P1-DIMMA2/P1-DIMMD2/P1-DIMMD1/P1-DIMME2/P1-DIMME1/P1-DIMMF1
1 CPU & 11 DIMMs*	CPU1: P1-DIMMC1/P1-DIMMC2/P1-DIMMB1/P1-DIMMB2/P1-DIMMA1/P1-DIMMA2/P1-DIMMD2/P1-DIMMD1/P1-DIMME2/P1-DIMME1/P1-DIMMF1
1 CPU & 12 DIMMs	CPU1: P1-DIMMC1/P1-DIMMC2/P1-DIMMB1/P1-DIMMB2/P1-DIMMA1/P1-DIMMA2/P1-DIMMD2/P1-DIMMD1/P1-DIMME2/P1-DIMME1/P1-DIMMF2/P1-DIMMF1
2 CPUs & 2 DIMMs	CPU1: P1-DIMMA1 CPU2: P2-DIMMA1
2 CPUs & 4 DIMMs	CPU1: P1-DIMMA1/P1-DIMMD1 CPU2: P2-DIMMA1/P2-DIMMD1
2 CPUs & 6 DIMMs	CPU1: P1-DIMMC1/P1-DIMMB1/P1-DIMMA1 CPU2: P2-DIMMC1/P2-DIMMB1/P2-DIMMA1
2 CPUs & 8 DIMMs	CPU1: P1-DIMMB1/P1-DIMMA1/P1-DIMMD1/P1-DIMME1 CPU2: P2-DIMMB1/P2-DIMMA1/P2-DIMMD1/P2-DIMME1
2 CPUs & 10 DIMMs	CPU1: P1-DIMMC1/P1-DIMMB1/P1-DIMMA1/P1-DIMMD1/P1-DIMME1/P1-DIMMF1 CPU2: P2-DIMMB1/P2-DIMMA1/P2-DIMMD1/P2-DIMME1
2 CPUs & 12 DIMMs	CPU1: P1-DIMMC1/P1-DIMMB1/P1-DIMMA1/P1-DIMMD1/P1-DIMME1/P1-DIMMF1 CPU2: P2-DIMMC1/P2-DIMMB1/P2-DIMMA1/P2-DIMMD1/P2-DIMME1/P2-DIMMF1
2 CPUs & 14 DIMMs	CPU1: P1-DIMMB1/P1-DIMMB2/P1-DIMMA1/P1-DIMMA2/P1-DIMMD2/P1-DIMMD1/P1-DIMME2/P1-DIMME1 CPU2: P2-DIMMC1/P2-DIMMB1/P2-DIMMA1/P2-DIMMD1/P2-DIMME1/P2-DIMMF1
2 CPUs & 16 DIMMs	CPU1: P1-DIMMB1/P1-DIMMB2/P1-DIMMA1/P1-DIMMA2/P1-DIMMD2/P1-DIMMD1/P1-DIMME2/P1-DIMME1 CPU2: P2-DIMMB1/P2-DIMMB2/P2-DIMMA1/P2-DIMMA2/P2-DIMMD2/P2-DIMMD1/P2-DIMME2/P2-DIMME1
2 CPUs & 18 DIMMs	CPU1: P1-DIMMC1/P1-DIMMC2/P1-DIMMB1/P1-DIMMB2/P1-DIMMA1/P1-DIMMA2/P1-DIMMD2/P1-DIMMD1/P1-DIMME2/P1-DIMME1/P1-DIMMF2/P1-DIMMF1 CPU2: P2-DIMMC1/P2-DIMMB1/P2-DIMMA1/P2-DIMMD1/P2-DIMME1/P2-DIMMF1
2 CPUs & 20 DIMMs	CPU1: P1-DIMMC1/P1-DIMMC2/P1-DIMMB1/P1-DIMMB2/P1-DIMMA1/P1-DIMMA2/P1-DIMMD2/P1-DIMMD1/P1-DIMME2/P1-DIMME1/P1-DIMMF2/P1-DIMMF1 CPU2: P2-DIMMB1/P2-DIMMB2/P2-DIMMA1/P2-DIMMA2/P2-DIMMD2/P2-DIMMD1/P2-DIMME2/P2-DIMME1
2 CPUs & 22 DIMMs*	CPU1: P1-DIMMC1/P1-DIMMC2/P1-DIMMB1/P1-DIMMB2/P1-DIMMA1/P1-DIMMA2/P1-DIMMD2/P1-DIMMD1/P1-DIMME2/P1-DIMME1/P1-DIMMF1 CPU2: P2-DIMMC1/P2-DIMMC2/P2-DIMMB1/P2-DIMMB2/P2-DIMMA1/P2-DIMMA2/P2-DIMMD2/P2-DIMMD1/P2-DIMME2/P2-DIMME1/P2-DIMMF1
2 CPUs & 24 DIMMs	CPU1: P1-DIMMC1/P1-DIMMC2/P1-DIMMB1/P1-DIMMB2/P1-DIMMA1/P1-DIMMA2/P1-DIMMD2/P1-DIMMD1/P1-DIMME2/P1-DIMME1/P1-DIMMF2/P1-DIMMF1 CPU2: P2-DIMMC1/P2-DIMMC2/P2-DIMMB1/P2-DIMMB2/P2-DIMMA1/P2-DIMMA2/P2-DIMMD2/P2-DIMMD1/P2-DIMME2/P2-DIMME1/P2-DIMMF2/P2-DIMMF1

*Unbalanced, not recommended.

Note: Please refer to the drawing on the next page for the locations of DIMM modules.

Symmetric Population within 1 CPU Socket													
Modes	P1-DIMMF1	P1-DIMMF2	P1-DIMME1	P1-DIMME2	P1-DIMMD1	P1-DIMMD2	P1-DIMMA2	P1-DIMMA1	P1-DIMMB2	P1-DIMMB1	P1-DIMMC2	P1-DIMMC1	Channel Config.
AD	DRAM1	DCPMM	DRAM1	DCPMM	DRAM1	DCPMM	DCPMM	DRAM1	DCPMM	DRAM1	DCPMM	DRAM1	2-2-2
MM	DRAM1	DCPMM	DRAM1	DCPMM	DRAM1	DCPMM	DCPMM	DRAM1	DCPMM	DRAM1	DCPMM	DRAM1	2-2-2
AD + MM	DRAM3	DCPMM	DRAM3	DCPMM	DRAM3	DCPMM	DCPMM	DRAM3	DCPMM	DRAM3	DCPMM	DRAM3	2-2-2
AD	DRAM1	-	DRAM1	-	DRAM1	DCPMM	DCPMM	DRAM1	-	DRAM1	-	DRAM1	2-1-1
MM	DRAM2	-	DRAM2	-	DRAM2	DCPMM	DCPMM	DRAM2	-	DRAM2	-	DRAM2	2-1-1
AD + MM	DRAM3	-	DRAM3	-	DRAM3	DCPMM	DCPMM	DRAM3	-	DRAM3	-	DRAM3	2-1-1
AD	DRAM1	-	DRAM1	DCPMM	DRAM1	DCPMM	DCPMM	DRAM1	DCPMM	DRAM1	-	DRAM1	2-2-1
MM	DRAM1	-	DRAM1	DCPMM	DRAM1	DCPMM	DCPMM	DRAM1	DCPMM	DRAM1	-	DRAM1	2-2-1
AD + MM	DRAM3	-	DRAM3	DCPMM	DRAM3	DCPMM	DCPMM	DRAM3	DCPMM	DRAM3	-	DRAM3	2-2-1
AD	DCPMM	-	DRAM1	-	DRAM1	-	-	DRAM1	-	DRAM1	-	DCPMM	1-1-1
MM	DCPMM	-	DRAM1	-	DRAM1	-	-	DRAM1	-	DRAM1	-	DCPMM	1-1-1
AD + MM	DCPMM	-	DRAM3	-	DRAM3	-	-	DRAM3	-	DRAM3	-	DCPMM	1-1-1
AD	DCPMM	-	DRAM1	DRAM1	DRAM1	DRAM1	DRAM1	DRAM1	DRAM1	DRAM1	-	DCPMM	2-2-1

Asymmetric Population within 1 CPU Socket													
Modes	P1-DIMMF1	P1-DIMMF2	P1-DIMME1	P1-DIMME2	P1-DIMMD1	P1-DIMMD2	P1-DIMMA2	P1-DIMMA1	P1-DIMMB2	P1-DIMMB1	P1-DIMMC2	P1-DIMMC1	Channel Config.
AD	DRAM1	-	DRAM1	-	DRAM1	-	DCPMM	DRAM1	-	DRAM1	-	DRAM1	2/1-1-1
AD*	DRAM1	-	DRAM1	-	DRAM1	-	DCPMM	DRAM1	-	DRAM1	-	DRAM1	2/1-1-1

Legend (for the two tables above)						
DDR4 Type					Capacity	
DRAM1	RDIMM	3DS RDIMM	LRDIMM	3DS LRDIMM	Any Capacity	
DRAM2	RDIMM	-	-	-	Refer to Validation Matrix (DDR4 DIMMs validated with DCPMM) below.	
DRAM3	RDIMM	3DS RDIMM	LRDIMM	-		

Note: DDR4 single rank x8 is not available for DCPMM Memory Mode or App-Direct Mode.

Legend (-for the two tables above)	
Capacity	
DCPMM	Any Capacity (Uniformly for all channels for a given configuration)

- * 2nd socket has no DCPMM DIMM
- For MM, general NM/FM ratio is between 1:4 and 1:16. Excessive capacity for FM can be used for AD. (NM = Near Memory; FM = Far Memory)
- For each individual population, rearrangements between channels are allowed as long as the resulting population is compliant with the PDG rules for the 82xx/62xx/52xx/42xx platform.
- For each individual population, please use the same DDR4 DIMM in all slots.
- For each individual population, sockets are normally symmetric with exceptions for 1 DCPMM per socket and 1 DCPMM per node case. Currently, DCPMM modules operate at 2666 MHz.
- No mixing of DCPMM and NVMDIMMs within the same platform is allowed.
- This DCPMM population guide targets a balanced DCPMM-to-DRAM-cache ratio in MM and MM + AD modes.

Validation Matrix (DDR4 DIMMs Validated w/DCPMM)			
DIMM Type	Ranks Per DIMM & Data Width (Stack)	DIMM Capacity (GB)	
		DRAM Density	
		4Gb	8Gb
RDIMM	1Rx4	8GB	16GB
	2Rx8	8GB	16GB
	2Rx4	16GB	32GB
LRDIMM	4Rx4	N/A	64GB
LRDIMM 3DS	8Rx4 (4H)	N/A	128GB

Mezzanine Card Installation (Optional)

For SAS 3.0 support, be sure to follow the instructions below to install the mezzanine card on the CPU JMEZZ1/2-PCI-E 3.0 located on the motherboard.

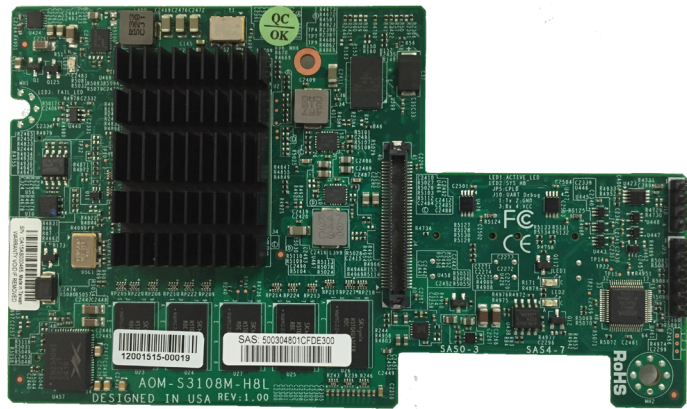
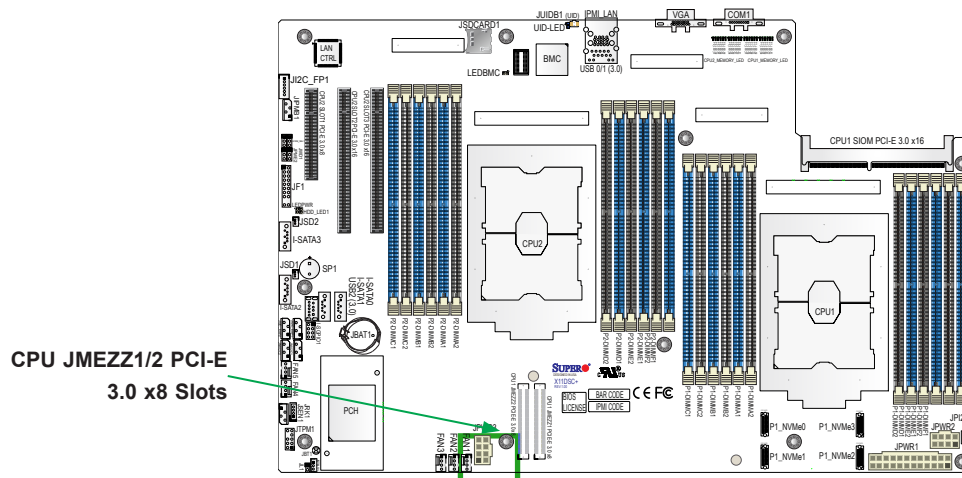
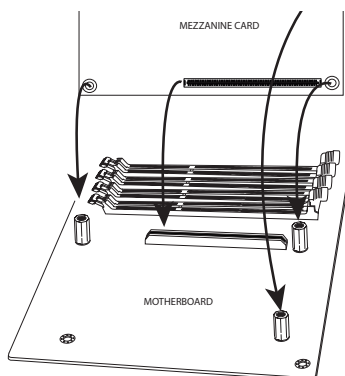

Image of the Mezzanine Card

1. After installing the motherboard in the chassis, align the mezzanine card(s) with the AOM PCI-E 3.0 slot(s) on the motherboard.



2. With both hands, press the mezzanine card down into the slot.



3. With the mezzanine card securely placed in the slot, insert Pan Head #6 screws into the three standoff holes and tighten them with a Phillips screwdriver.

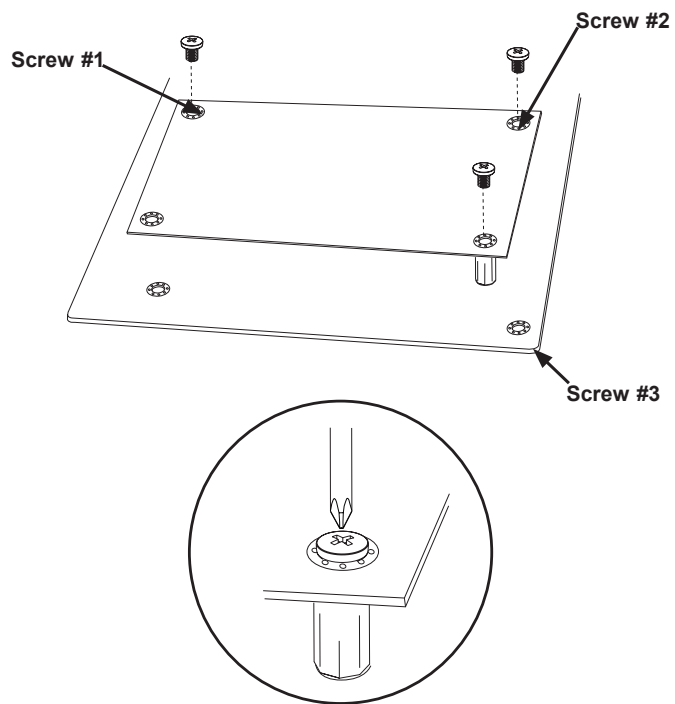

Motherboard Battery

The motherboard uses non-volatile memory to retain system information when system power is removed. This memory is powered by a lithium battery residing on the motherboard.

Replacing the Battery

Begin by removing power from the system as described in section 3.1.

1. Push aside the small clamp that covers the edge of the battery. When the battery is released, lift it out of the holder.
2. To insert a new battery, slide one edge under the lip of the holder with the positive (+) side facing up. Then push the other side down until the clamp snaps over it.

Note: Handle used batteries carefully. Do not damage the battery in any way; a damaged battery may release hazardous materials into the environment. Do not discard a used battery in the garbage or a public landfill. Please comply with the regulations set up by your local hazardous waste management agency to dispose of your used battery properly.

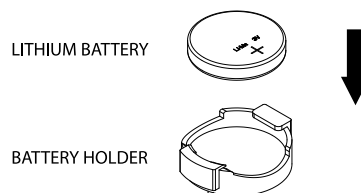

Figure 3-3. Installing the Onboard Battery

Warning: There is a danger of explosion if the onboard battery is installed upside down (which reverses its polarities). This battery must be replaced only with the same or an equivalent type recommended by the manufacturer (CR2032).

3.4 Chassis Components

Removing Power from the System

Before performing some setup or maintenance tasks, use the following procedure to ensure that power has been removed from the system.

1. Use the operating system to power down the node, following the on-screen prompts.
2. After the system has completely shut-down, carefully grasp the head of the power cord and gently pull it out of the back of the power supply. If your system has dual power supplies, remove the cords from both power supplies.
3. Disconnect the cords from the power strip or wall outlet.

Storage Drives

The SC826 chassis supports twenty-four 3.5" SAS3 hard disk drives. They can be removed without powering down the system if your operating system supports RAID.

There are also two hot-swap hard drive bays in the rear.

Note: Enterprise level hard disk drives are recommended for use in Supermicro servers. For information on recommended drives, visit the Supermicro website.

Drive Carriers

The drives are mounted in drive carriers to simplify their installation and removal from the chassis. These carriers also help promote proper airflow through the drive bays. Each drive carrier has two LED indicators. These are described in Chapter 4.

Removing Drive Carriers from the Chassis

1. To access mid-chassis drives, open the mid-chassis cover and lift the drive rack.
2. Slide the release button toward the side of the drive carrier, which extends the drive carrier handle.
3. Use the drive carrier handle to pull the drive out of the chassis.

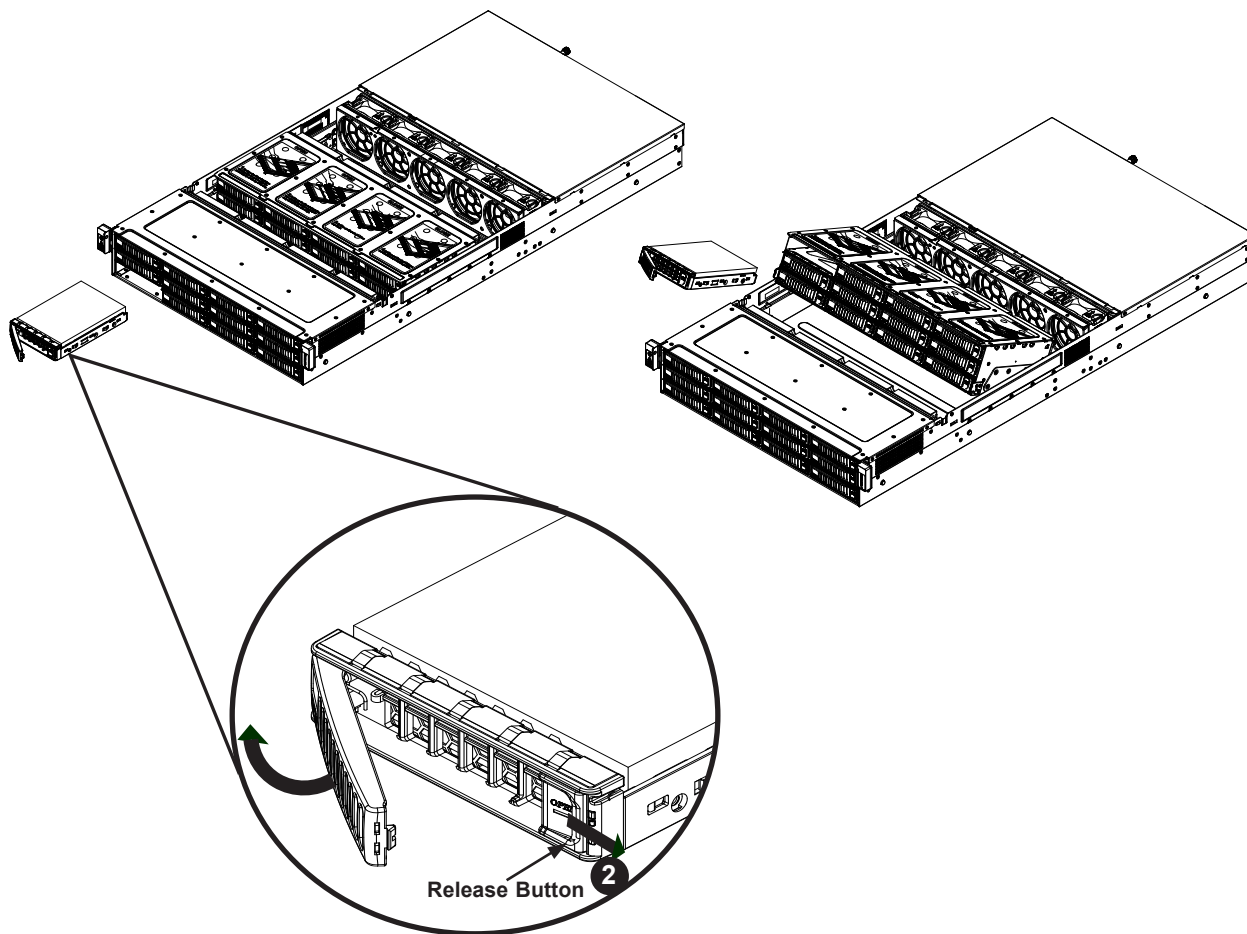

Figure 3-4. Removing a Drive Carrier

Installing a Hard Disk Drive

1. Remove the screws securing the dummy drive to the carrier.
2. Remove the dummy drive from the carrier.

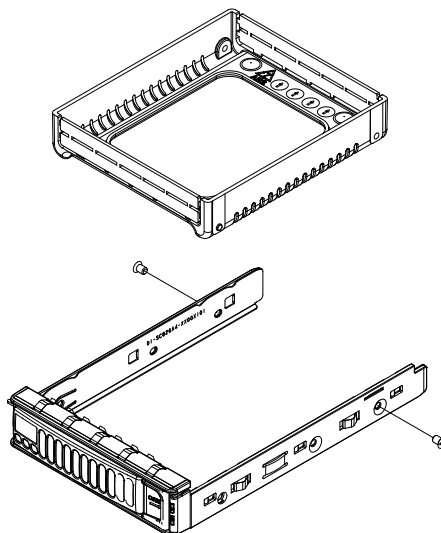

Figure 3-5. Removing a Dummy Drive from the Drive Carrier

3. Insert the drive into the carrier with the printed circuit board side facing downward and so that the mounting holes in the drive align with those in the carrier.
4. Secure the drive to the carrier with the four screws included with the drive.
5. Insert the drive and carrier into its bay, keeping the carrier oriented so that the release button is on the right. When the carrier reaches the rear of the bay, the release handle will retract.
6. Using the thumb, push the drive carrier handle until it clicks into the locked position.

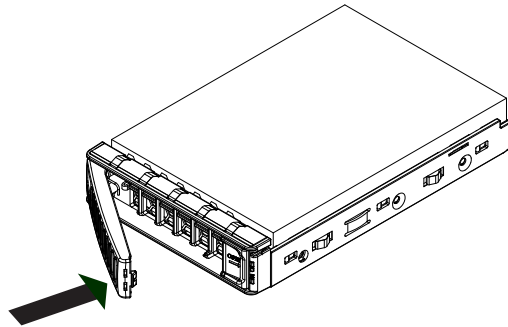

Figure 3-6. Locking the Drive Carrier into Place

Caution: Except for short periods of time, such as swapping hard drives, do not operate the server with the hard drive bays empty.

Note: Enterprise level hard disk drives are recommended for use in Supermicro chassis and servers. For information on recommended HDDs, visit the Supermicro website at <http://www.supermicro.com/products/nfo/files/storage/SBB-HDDCompList.pdf>

Installing Rear Hard Drives

The two drives in the rear of the chassis are installed in the same way as the main storage drives.

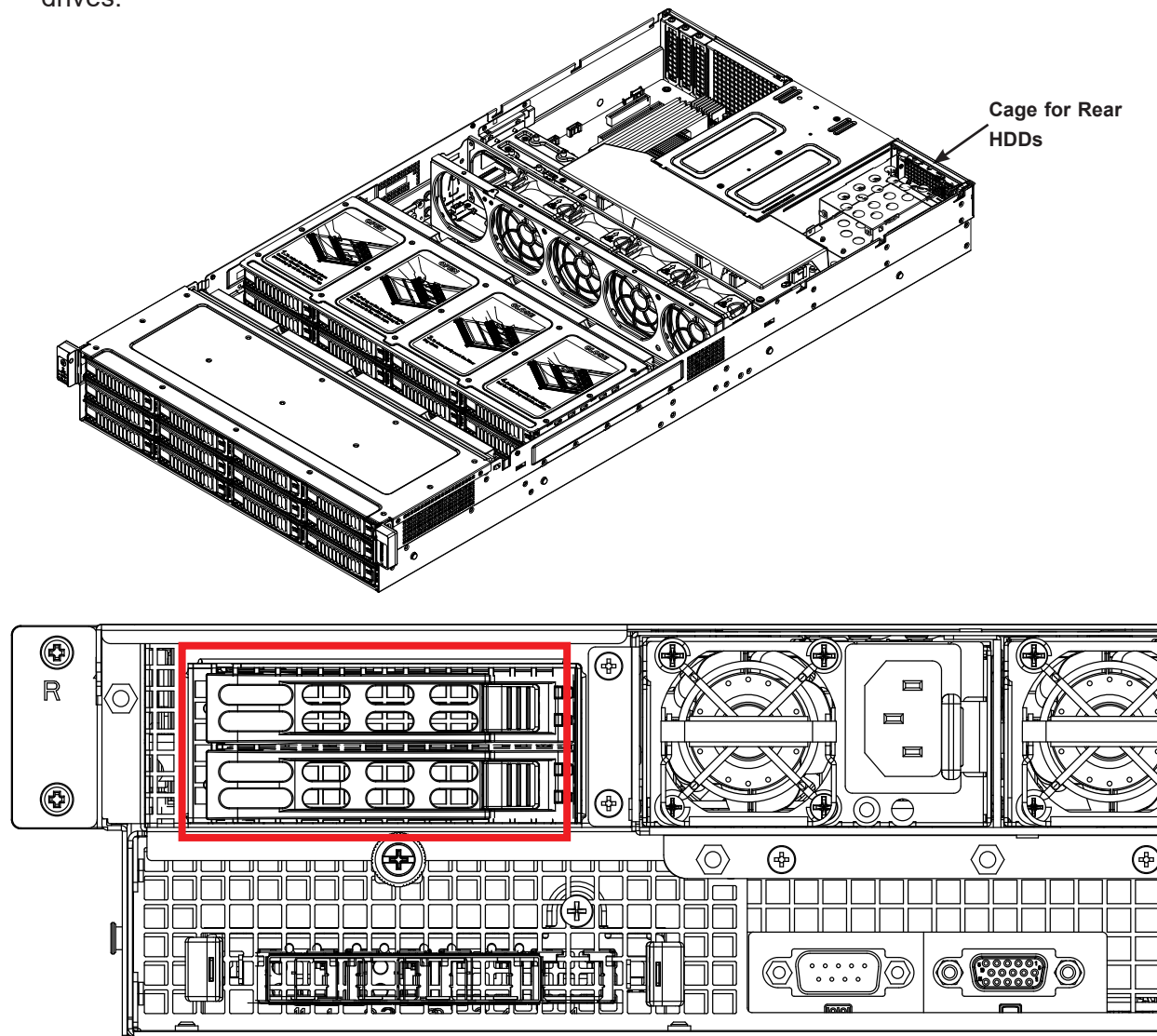

Figure 3-7. Rear HDDs

Installing the Expansion Cards

The system provides three PCI slots for low-profile, half-length expansion cards.

Installing an Expansion Cards

1. Power down the system and remove both covers as described in earlier in this section.
2. In the rear of the chassis, remove the screw securing the PCI slot shield in the PCI slot that you wish to use.
3. Slide the expansion card bracket into the open PCI slot while plugging the expansion card into the motherboard.
4. Secure the expansion card bracket into the PCI slot using the screw previously set aside.
5. Replace the top covers and power up the system.

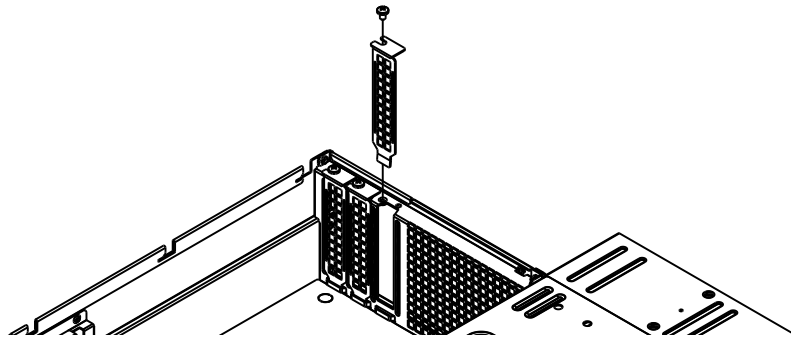

Figure 3-8. Removing the PCI Slot Shield

Installing a SIOM Card

The SIOM card provides options for network connection. It is inserted into a SIOM slot on the motherboard. This installation is usually performed by a system integrator or manufacturer.

Installing a SIOM Card

1. Power down the system as described earlier in this section.

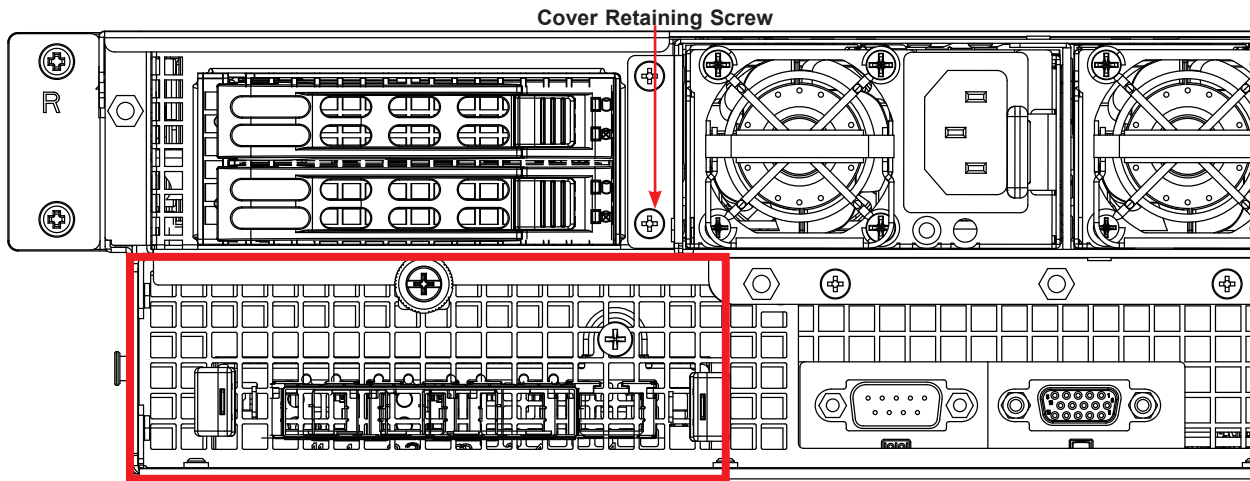

Figure 3-9. SIOM Card Position on Chassis Rear

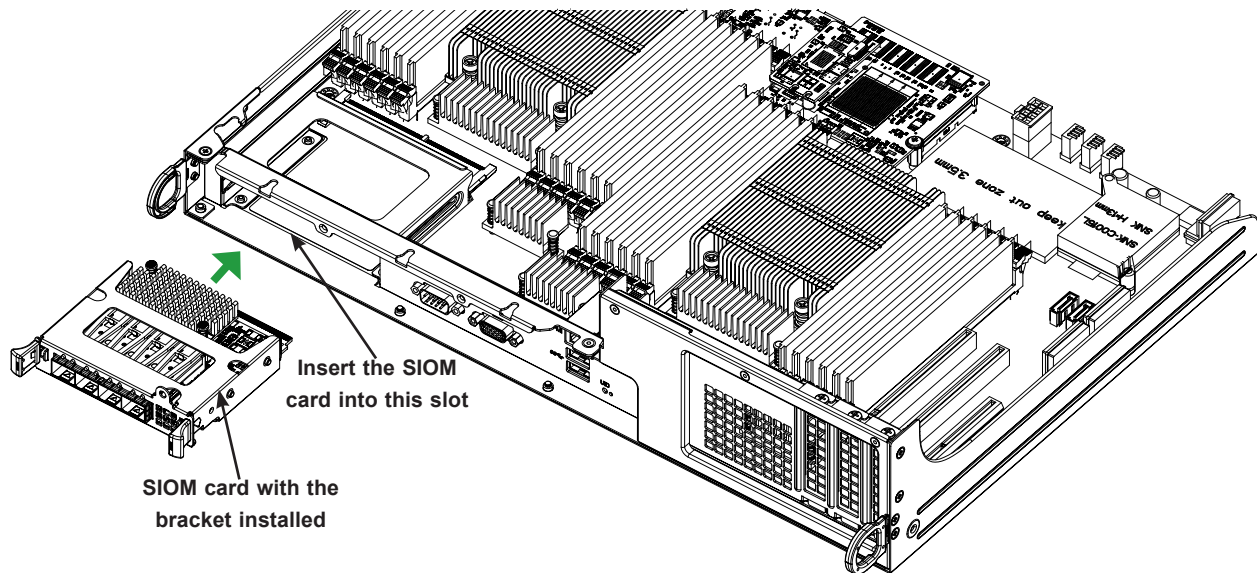

Figure 3-10. Inserting SIOM Card

2. Remove the small section of the chassis rear to allow access to the motherboard SIOM slot. Unscrew the single retaining screw to remove the cover.
3. Position the card with its cover bracket in front of the SIOM slot and gently push in both sides of the card until it slides into the slot.
4. Secure the SIOM card cover bracket to the chassis with the screw.

Installing Front Optional NVMe Drives with Cable

Front mounted NVMe drives can be installed in the chassis with an optional kit. The NVMe kit set comes with:

- 4x CBL-SAST-0929 cables
- 4x MCP-220-00140-0B

Removing the server from the rack is required for this installation.

Installing the Optional Front NVMe Drives

1. Follow the steps for shutting down power and removing the mid-chassis cover from the system from Sections 3.1 and 3.2.
2. After removing the rear cover, remove the black plastic cable management shield by pulling on the two black knobs on each side shown below.

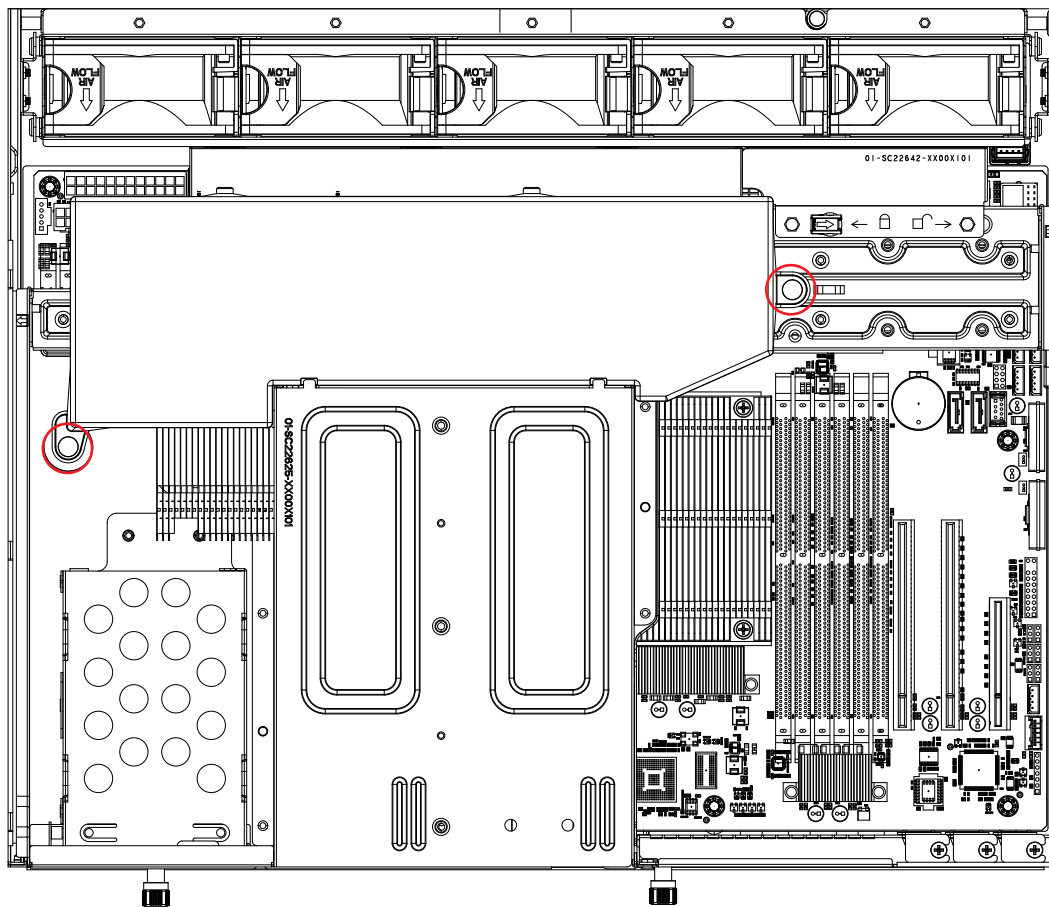

Figure 3-11. Knobs Securing the Cable Management Shield

3. You will see the power distribution board with a metal platform supporting it as shown below. Remove the smaller metal piece securing it and remove this metal platform.

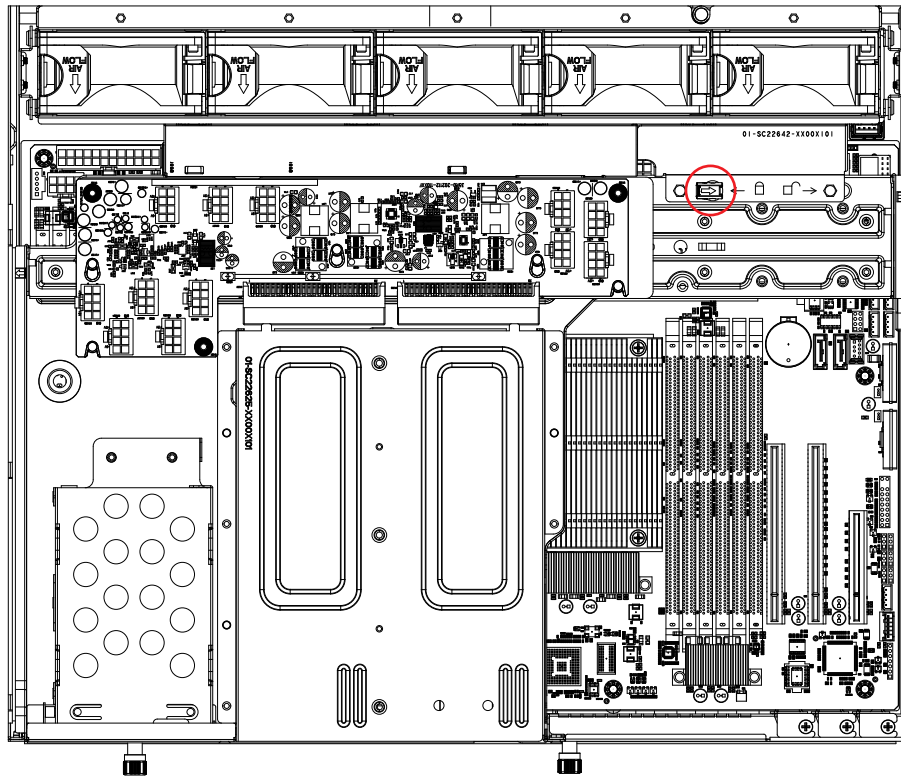

Figure 3-12. Removing the Metal Platform Supporting the Power Distribution Board

4. Unplug the power cable (location shown below) from the motherboard. Be extremely careful while un-installing this cable when reaching underneath to the motherboard.

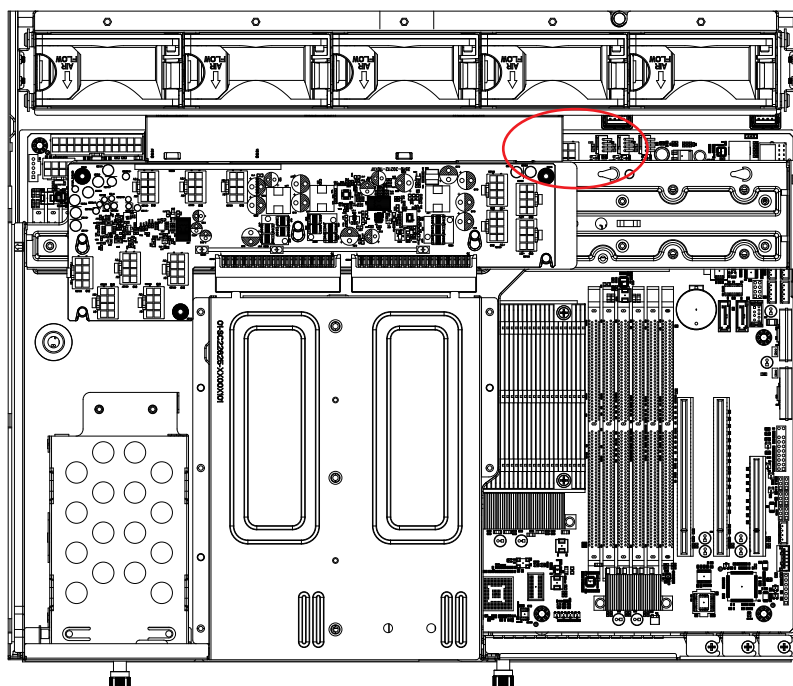

Figure 3-13. Unplugging the Power Cable

5. Disconnect the power supplies, then unscrew the two knobs shown below and carefully flip the metal platform up and off.

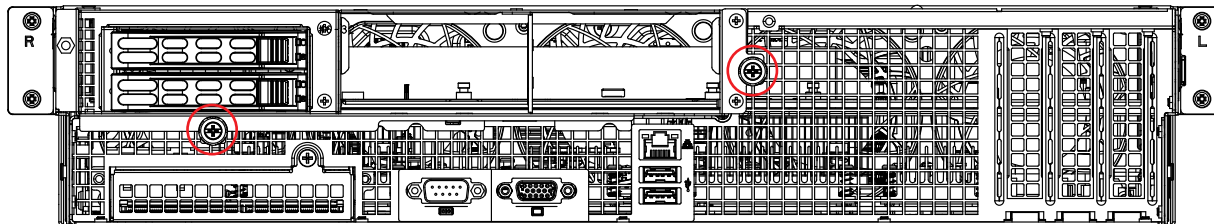

Figure 3-14. Removing the Knobs Securing the Metal Platform

6. Locate the four NVMe ports as shown in the motherboard below.

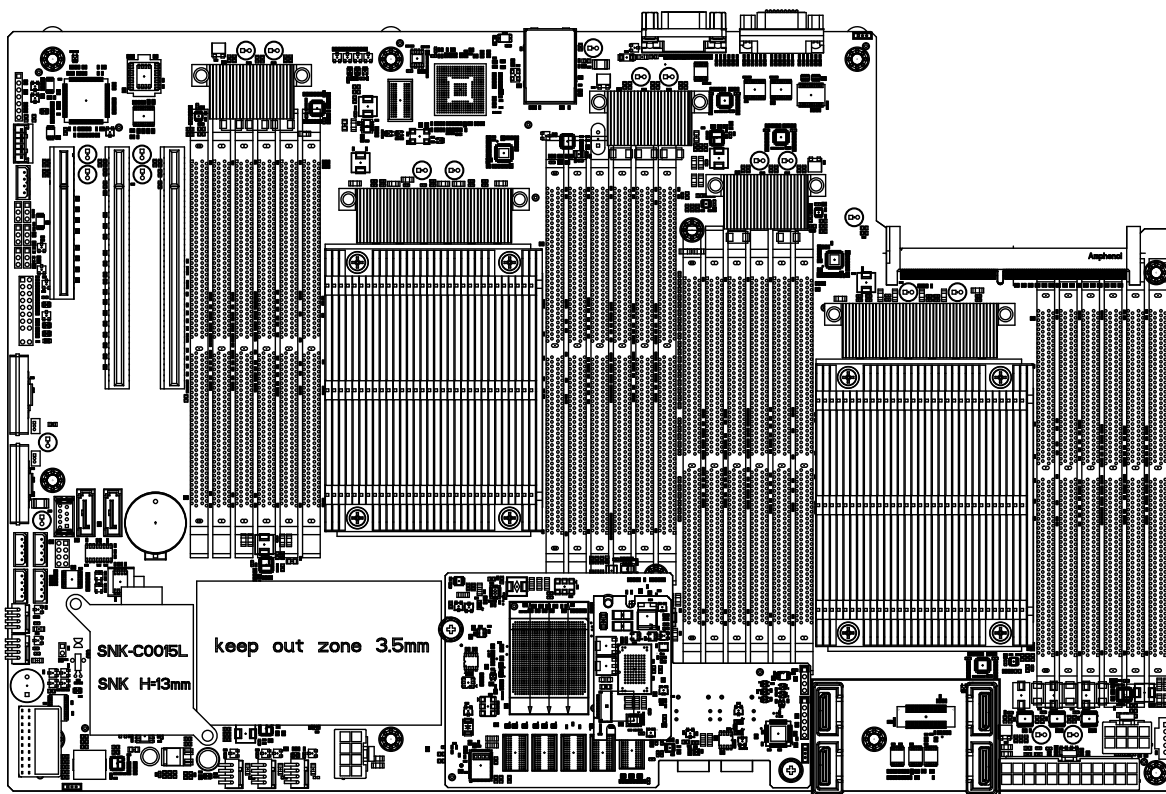

Figure 3-15. Locating the NVMe Ports on the Motherboard

7. Connect the four CBL-SAST-0929 cables from the motherboard's P1_NVMe0 - P1_NVMe3 ports to the second backplane's JSM4 – JSM7 ports respectively as shown below. Please notice that the arrangement of ports on the backplane is not in sequence due to design limitations..

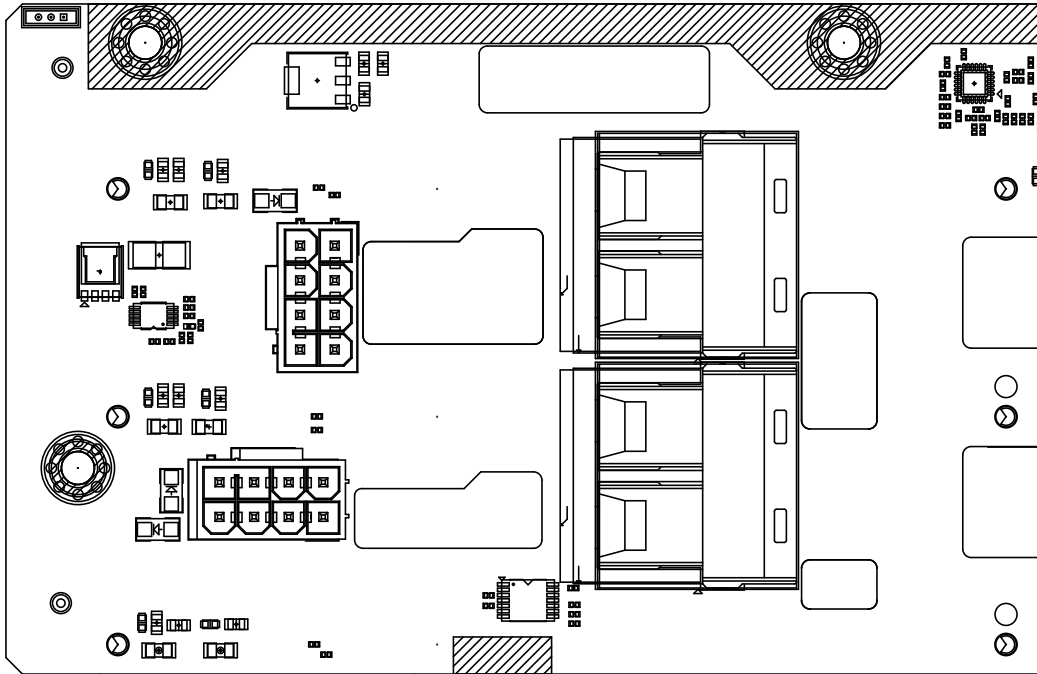

Figure 3-16. NVMe Ports

8. The four NVMe drives have to be installed in the last four slots of the second backplane, namely slots 20-23. In addition, it is recommended that you always install the NVMe drives in an ascending matter, for instance install drive slot 20 first.
9. Please follow installation instruction from section “Installing a Hard Disk Drive” for drive tray installation.

System Fans

Five 8-cm heavy-duty fans provide cooling for the system. They can be replaced without powering down the system.

Replacing a System Fan

1. If necessary, open the chassis while the power is running to determine which fan requires changing. (Never run the server for an extended period of time with the chassis open.)
2. Open the mid-chassis cover as described earlier in this section.
3. Press the fan release tab to lift the failed fan from the chassis and pull it completely out of the chassis.
4. Place the new fan into the vacant space in the housing while making sure the arrows on the top of the fan (indicating air direction) point in the same direction as the arrows on the other fans.
5. The fan will automatically begin running at the correct speed.

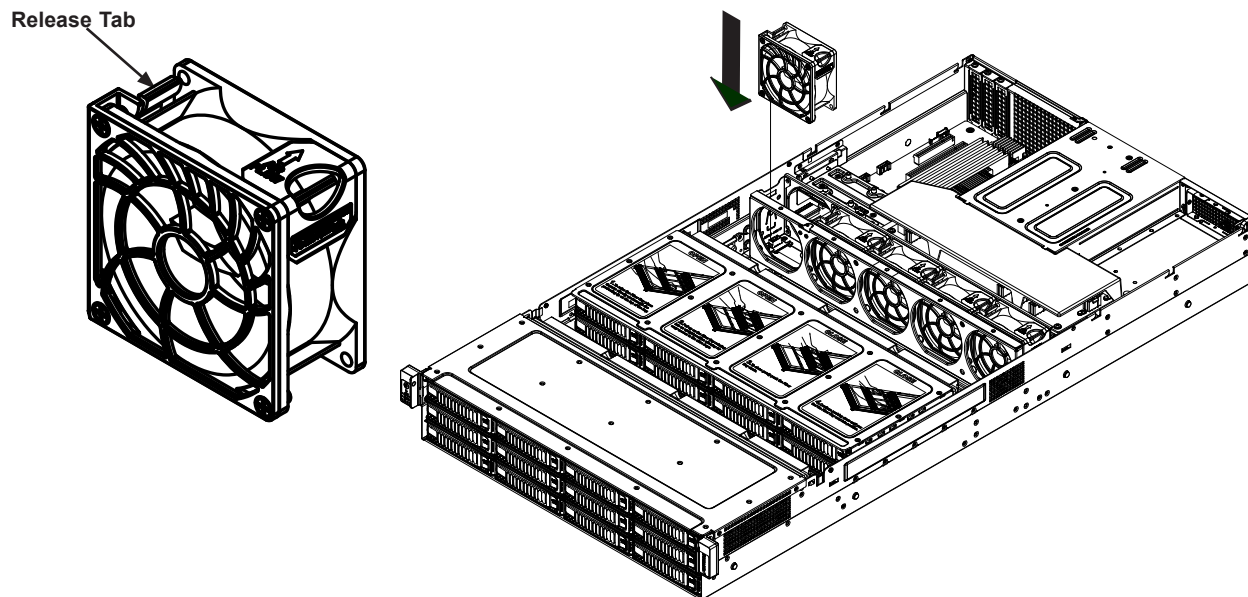

Figure 3-17. Placing a System Fan

Installing the Air Shrouds

Air shrouds concentrate airflow to maximize fan efficiency. They do not require screws for installation.

Installing the Air Shroud

1. Power down the system and remove the covers as described earlier in this section.
2. Place the large mylar air shroud in the chassis. It fits just behind the fans and under the power supply housing as shown below.

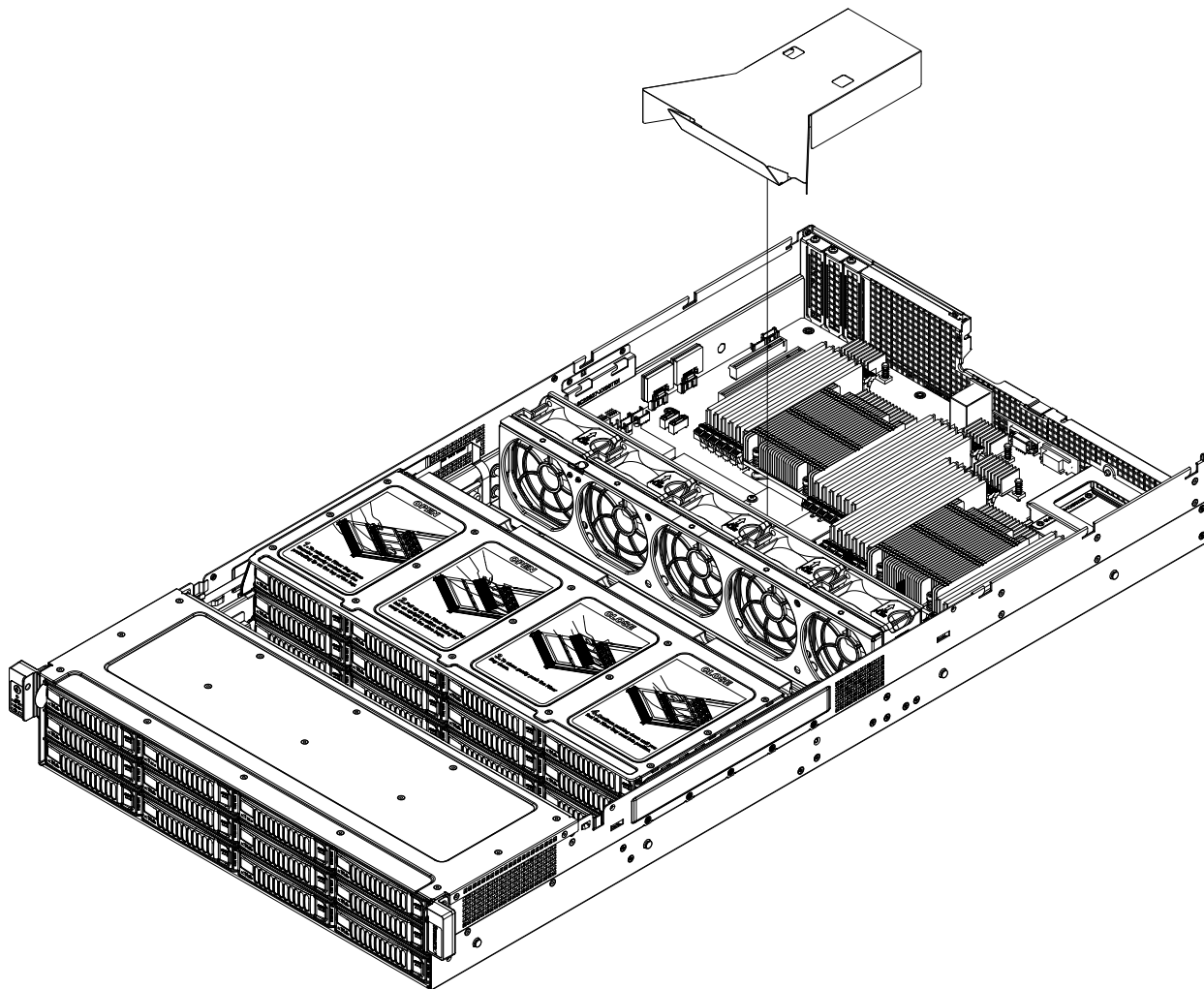

Figure 3-18. Mylar Air Shroud Installation

3. Place the smaller air shrouds. (Figure 3-13) Align the mounting holes in the air shroud with those in the chassis and secure them with the three screws provided with the air shroud.

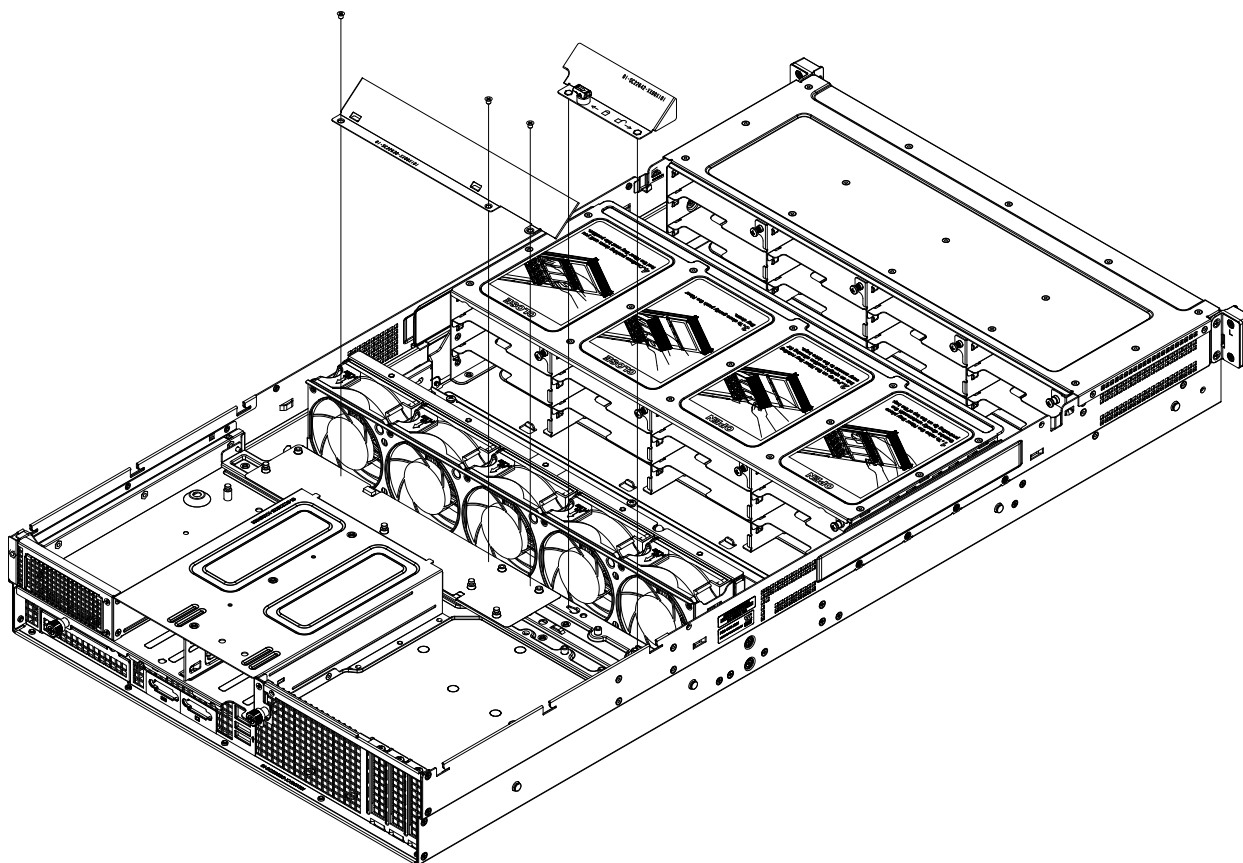

Figure 3-19. Air Shroud Installation

4. Replace both chassis covers and power up the system.

Power Supply

The chassis features redundant 1600 Watt power supplies. The power modules can be changed without powering down the system. New units can be ordered directly from Supermicro or authorized distributors.

These power supplies are auto-switching capable. This feature enables them to automatically sense the input voltage and operate at a 100-120v or 180-240v. An amber light will be illuminated on the power supply when the power is off. An illuminated green light indicates that the power supply is operating.

Changing the Power Supply:

1. Unplug the AC cord from the module to be replaced.
2. Push the release tab on the back of the power supply as illustrated.
3. Pull the power supply out using the handle provided.

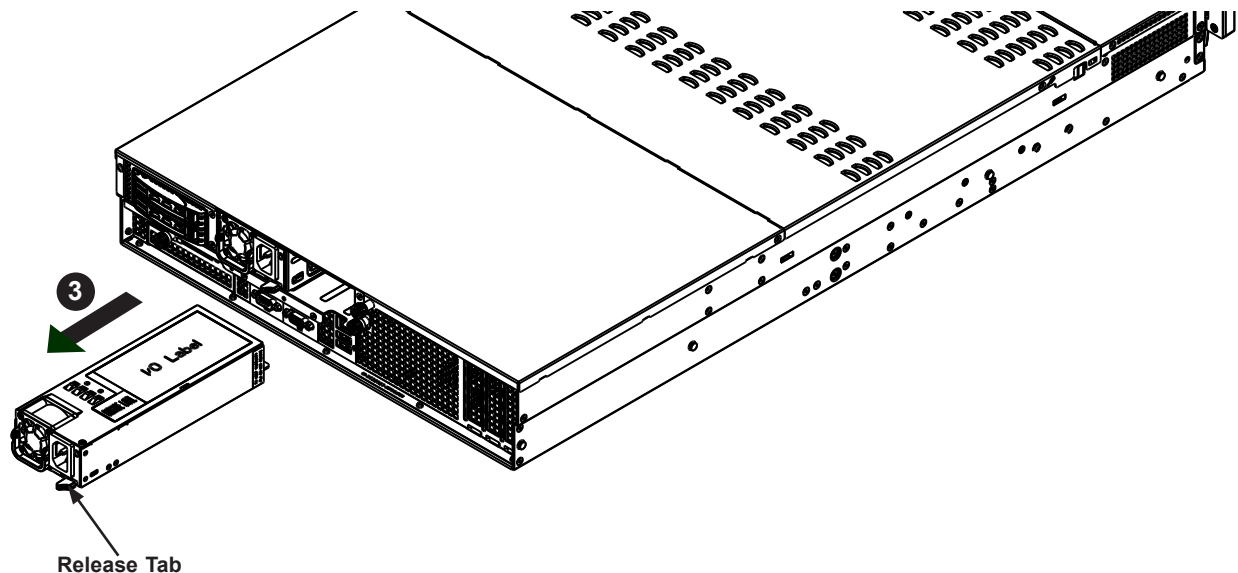

Figure 3-20. Power Supply Release Tab

4. Replace the failed power module with the same model.
5. Push the new power supply module into the power bay until it clicks.
6. Plug the AC power cord back into the module.

Chapter 4

Motherboard Connections

This section describes the connections on the motherboard and provides pinout definitions. Note that depending on how the system is configured, not all connections are required. The LEDs on the motherboard are also described here. A serverboard layout indicating component locations may be found in Chapter 1.

Please review the Safety Precautions in Chapter 3 before installing or removing components.

4.1 Power Connections

ATX and CPU Power Connectors

JPWR1 is the 24-pin ATX main power supply connector. This primary power supply connector meets the ATX SSI EPS 24-pin specification. You must also connect the 8-pin (JPWR2/JPWR3) CPU power connectors to your power supply.

ATX Power 24-pin Connector Pin Definitions			
Pin#	Definition	Pin#	Definition
13	+3.3V	1	+3.3V
14	NC	2	+3.3V
15	Ground	3	Ground
16	PS_ON	4	+5V
17	Ground	5	Ground
18	Ground	6	+5V
19	Ground	7	Ground
20	Res (NC)	8	PWR_OK
21	+5V	9	5VSB
22	+5V	10	+12V
23	+5V	11	+12V
24	Ground	12	+3.3V

12V 8-pin CPU Power Connectors

JPWR2 and JPWR3 are the 8-pin 12V DC power input for the CPU. Refer to the table below for pin definitions.

12V 8-pin Power Pin Definitions	
Pin#	Definition
1 - 4	Ground
5 - 8	+12V

4.2 Ports

Rear I/O Ports

See Figure 4-1 below for the locations and descriptions of the various I/O ports on the rear of the motherboard.

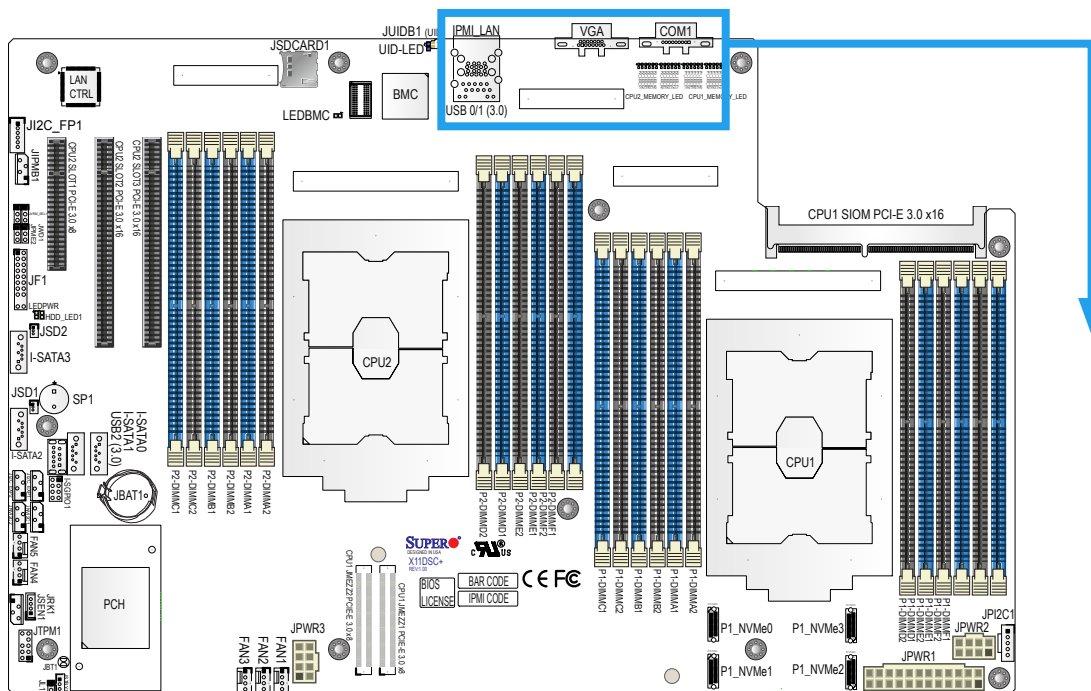

Figure 4-1. Back panel I/O Port Locations and Definitions

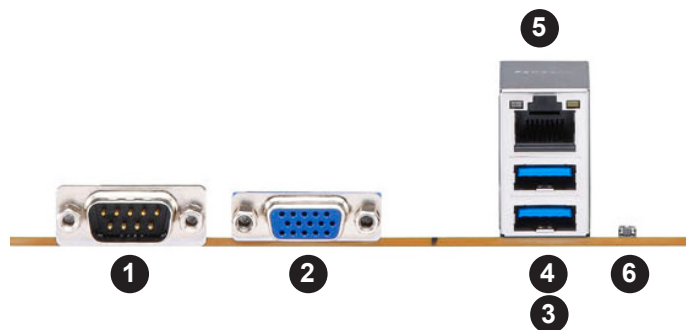

Figure 4-2. Back Panel I/O Port Locations and Definitions

Back Panel I/O Ports			
No.	Description	No.	Description
1.	COM1	4.	USB 1 (USB 3.0)
2.	VGA	5.	IPMI LAN
3.	USB 0 (USB 3.0)	6.	Unit Identifier Switch (UID)

Universal Serial Bus (USB) Ports

There are two USB 3.0 ports (USB0/1) on the I/O back panel. USB2 is a Type A USB 3.0 header on the motherboard to provide front access USB connection. The onboard headers can be used to provide front side USB access with a cable (not included).

Back Panel USB 0/1 (3.0) Pin Definitions			
Pin#	Definition	Pin#	Definition
A1	VBUS	B1	Power
A2	D-	B2	USB_N
A3	D+	B3	USB_P
A4	GND	B4	GND
A5	Stda_SSRX-	B5	USB3_RN
A6	Stda_SSRX+	B6	USB3_RP
A7	GND	B7	GND
A8	Stda_SSTX-	B8	USB3_TN
A9	Stda_SSTX+	B9	USB3_TP

Type A USB 2 (3.0) Pin Definitions			
Pin#	Definition	Pin#	Definition
1	VBUS	5	SSRX-
2	USB_N	6	SSRX+
3	USB_P	7	GND
4	Ground	8	SSTX-
		9	SSTX+

Unit Identifier Switch/UID LED Indicator

A Unit Identifier (UID) switch and a rear UID LED (UID-LED) are located on the I/O back panel. A front UID switch is located on pins 7 & 8 of the front panel control (JF1). When you press the front or the rear UID switch, both front and rear UID LEDs will be turned on. Press the UID switch again to turn off the LED indicators. The UID indicators provide easy identification of a system that may be in need of service. (**Note:** UID can also be triggered via IPMI on the motherboard. For more information, please refer to the IPMI User's Guide posted on our website at <http://www.supermicro.com>.)

UID Switch Pin Definitions	
Pin#	Definition
1	Ground
2	Ground
3	Button In
4	Button In

UID LED Pin Definitions	
Color	Status
Blue: On	Unit Identified

VGA Port

The onboard VGA port is located next to IPMI LAN port on the I/O back panel. Use this connection for VGA display.

Serial Port

There is one COM port (COM1) on the I/O back panel. The COM port provides serial communication support.

4.3 Headers

Onboard Fan Header

Five 4-pin fan headers (FAN1~5) are located on the motherboard to provide CPU/system cooling. These fan headers support both 3-pin fans and 4-pin fans; however, onboard fan speed control is available only when all 4-pin fans are used in the motherboard. Fan speed control is supported by a thermal management setting in the BMC (Baseboard Management Controller). See the table below for pin definitions.

Fan Header Pin Definitions	
Pin#	Definition
1	Ground (Black)
2	+12V (Red)
3	Tachometer
4	PWM Control

NVMe Connectors

Use the NVMe connectors (P1_NVMe0/P1_NVMe1/P1_NVMe2/P1_NVMe3) to attach high-speed PCI-E storage devices (supported by CPU1).

I-SATA 3.0 and S-SATA 3.0 Ports

The X11DSC+ has eight I-SATA 3.0 ports (I-SATA0-3, I-SATA4-7) and six S-SATA ports (S-SATA0-3, S-SATA4, S-SATA5) on the motherboard. The I-SATA ports are supported by the Intel PCH C621 chipset, and the S-SATA ports are supported by Intel SCU. S-SATA4/S-SATA5 can be used with Supermicro SuperDOMs which are yellow SATA DOM connectors with power pins built in, and do not require external power cables.

SATA 3.0 Port Pin Definitions	
Pin#	Signal
1	Ground
2	SATA_TXP
3	SATA_TXN
4	Ground
5	SATA_RXN
6	SATA_RXP
7	Ground

SATA Power Connectors

The SATA power connectors at JSD1 and JSD2 provide 5V power to onboard SATA devices. Refer to the table below for pin definitions.

SATA Power Pin Definitions	
Pin#	Definition
1	5V
2	Ground
3	Ground

TPM Header

The JTPM1 header is used to connect a Trusted Platform Module (TPM)/Port 80, which is available from a third-party vendor. A TPM/Port 80 connector is a security device that supports encryption and authentication in hard drives. It allows the motherboard to deny access if the TPM associated with the hard drive is not installed in the system. See the table below for pin definitions.

Trusted Platform Module/Port 80 Header Pin Definitions			
Pin#	Definition	Pin#	Definition
1	P3V3	2	SPI_TPM_CS_N
3	PCIE_RESET_N#	4	SPI_PCH_MISO
5	SPI_PCH_CLK#	6	Ground
7	SPI_PCH_MOSI	8	N/A
9	JTPM1_P3V3A	10	IRQ_TPM_SPIN_N

Internal Speaker/Buzzer

The Internal Speaker/Buzzer (SP1) is used to provide audible indications for various beep codes. See the table below for pin definitions.

Internal Buzzer Pin Definitions		
Pin#	Definition	
1	Pos (+)	Beep In
2	Neg (-)	Alarm Speaker

RAID Key Header

A RAID Key header is located at JRK1 on the motherboard. The RAID key is used to support NVMe SSD.

Intel® RAID Key Pin Definitions	
Pin#	Definition
1	Ground
2	3.3V Standby
3	Ground
4	PCH RAID Key

SGPIO Header

The I-SGPIO1 (Serial General Purpose Input/Output) header is used to communicate with the enclosure management chip on the backplane.

SGPIO Header Pin Definitions			
Pin#	Definition	Pin#	Definition
1	NC	2	NC
3	Ground	4	DATA Out
5	Load	6	Ground
7	Clock	8	NC

NC = No Connection

Standby Power

The Standby Power header is located at JSTBY1 on the motherboard. You must have a card with a Standby Power connector and a cable to use this feature. Refer to the table below for pin definitions.

Standby Power Pin Definitions	
Pin#	Definition
1	+5V Standby
2	Ground
3	No Connection

Power SMBus (I2C) Header

The Power System Management Bus (I2C) header at JPI2C1 monitors the power supply input/output voltages, fans, temperatures, and status. Refer to the table below for pin definitions.

Power SMBus Header Pin Definitions	
Pin#	Definition
1	Clock
2	Data
3	PMBUS_Alert
4	Ground
5	+3.3V

Chassis Intrusion

A Chassis Intrusion header is located at JL1 on the motherboard. Attach the appropriate cable from the chassis to inform you of a chassis intrusion when the chassis is opened. Refer to the table below for pin definitions.

Chassis Intrusion Pin Definitions	
Pin#	Definition
1	Intrusion Input
2	Ground

4-pin BMC External I2C Header

A System Management Bus header for IPMI 2.0 is located at JIPMB1. Connect the appropriate cable here to use the IPMB I2C connection on your system. Refer to the table below for pin definitions.

External I2C Header Pin Definitions	
Pin#	Definition
1	Data
2	Ground
3	Clock
4	No Connection

NVMe SMBus Headers

NVMe SMBus (I2C) headers (JNVI2C1/2), used for PCI-E SMBus clock and data connections, provide hot-plug support via a dedicated SMBus interface. This feature is only available for a Supermicro complete system with an SMCI-proprietary NVMe add-on card and cable installed. See the table below for pin definitions.

NVMe SMBus Header Pin Definitions	
Pin#	Definition
1	Data
2	Ground
3	Clock
4	VCCIO

SMB (I2C) for LCD Connector

The connector used for System Management Bus (I2C) for LCD devices is located at JI2C_FP1. Connect a cable here to provide health monitoring and management for LCD devices.

SMB (I2C) for SAS3 Backplanes Connectors

JI2C_EXP1/2 connectors are used for System Management Bus (I2C) for the devices installed on the SAS3 backplanes. Connect appropriate cables to these connectors for SAS3 health monitoring and system management.

Disk-On-Module Power Connector

The Disk-On-Module (DOM) power connectors at JSD1 and JSD2 provide 5V power to a solid-state DOM storage devices connected to one of the SATA ports. See the table below for pin definitions.

DOM Power Pin Definitions	
Pin#	Definition
1	5V
2	Ground
3	Ground

Inlet Sensor Header

This header (JSEN1) allows BMC to monitor thermal inlet temperature. A special module is required. Please contact Supermicro at www.supermicro.com to purchase the module for this header. Refer to the table below for pin definitions.

Inlet Sensor Header Pin Definitions	
Pin#	Definition
1	SMBDAT
2	Ground
3	SMBCLK
4	3.3V STBY

4.4 Front Control Panel

JF1 contains header pins for various buttons and indicators that are normally located on a control panel at the front of the chassis. These connectors are designed specifically for use with Supermicro chassis. See the figure below for the descriptions of the front control panel buttons and LED indicators.

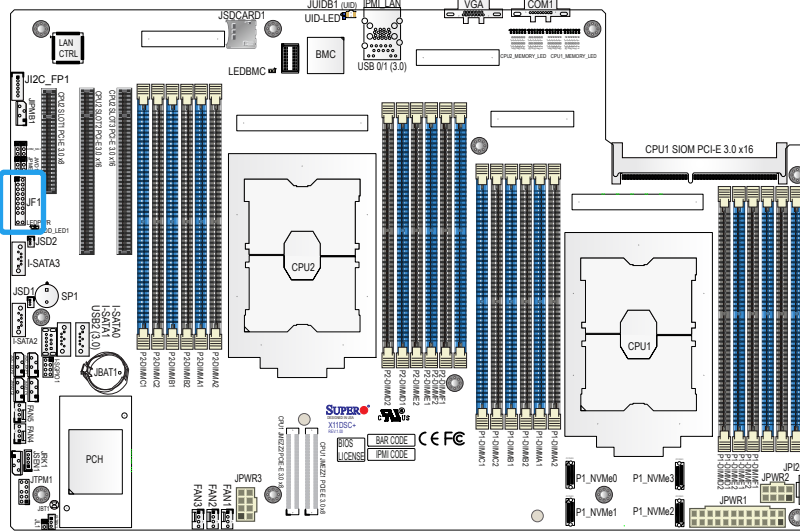

Figure 4-3. JF1 Header Pins

	1	2	
PWR } Power Button	○	○	Ground
Reset } Reset Button	○	○	Ground
3.3V	○	○	Power Fail LED
UID LED	○	○	OH/Fan Fail LED
3.3V Stby	○	○	NIC2 Active LED
3.3V Stby	○	○	NIC1 Active LED
3.3V Stby	○	○	HDD LED
3.3V Stby	○	○	PWR LED
X	○	○	X
NMI	○	○	Ground
	19	20	

Power Button

The Power Button connection is located on pins 1 and 2 of JF1. Momentarily contacting both pins will power on/off the system. This button can also be configured to function as a suspend button (with a setting in the BIOS - see Chapter 4). To turn off the power when the system is in suspend mode, press the button for 4 seconds or longer. Refer to the table below for pin definitions.

Power Button Pin Definitions (JF1)	
Pins	Definition
1	Signal
2	Ground

Reset Button

The Reset Button connection is located on pins 3 and 4 of JF1. Attach it to a hardware reset switch on the computer case to reset the system. Refer to the table below for pin definitions.

Reset Button Pin Definitions (JF1)	
Pins	Definition
3	Reset
4	Ground

Power Fail LED

The Power Fail LED connection is located on pins 5 and 6 of JF1. Refer to the table below for pin definitions.

Power Fail LED Pin Definitions (JF1)	
Pins	Definition
5	3.3V
6	PWR Supply Fail

OH/Fan Fail/PWR Fail/UID LED

Connect an LED cable to pins 7 and 8 of the Front Control Panel (JF1) to use UID/Overheat/Fan Fail/Power Fail LED connections. The LED on pin 8 provides warnings of overheat, power failure or fan failure. Refer to the tables below for details.

Informational LED-UID/OH/PWR Fail/Fan Fail LED Pin Definitions (Pin 7 & Pin 8 of JF1)	
Status	Description
Solid red	An overheat condition has occurred. (This may be caused by cable congestion).
Blinking red (1Hz)	Fan failure: check for an inoperative fan.
Blinking red (0.25Hz)	Power failure: check for a non-operational power supply
Solid blue	Local UID is activated. Use this function to locate a unit in a rack mount environment that might be in need of service.
Blinking blue (300 msec)	Remote UID is on. Use this function to identify a unit from a remote location that might be in need of service.

NIC1/NIC2 (LAN1/LAN2)

The NIC (Network Interface Controller) LED connection for LAN port 1 is located on pins 11 and 12 of JF1, and LAN port 2 is on pins 9 and 10. Attach the NIC LED cables here to display network activity. Refer to the table below for pin definitions.

LAN1/LAN2 LED Pin Definitions (JF1)	
Pins	Definition
9	NIC 2 Activity LED
10	3.3V Stby
11	NIC 1 Activity LED
12	3.3V Stby

HDD LED

The HDD LED connection is located on pins 13 and 14 of JF1. Attach a cable to pin 14 to show hard drive activity status. Refer to the table below for pin definitions.

HDD LED Pin Definitions (JF1)	
Pins	Definition
13	3.3V Stdbby
14	HDD Active

Power LED

The Power LED connection is located on pins 15 and 16 of JF1. Refer to the table below for pin definitions.

Power LED Pin Definitions (JF1)	
Pins	Definition
15	3.3V
16	PWR LED

NMI Button

The non-maskable interrupt (NMI) button header is located on pins 19 and 20 of JF1. Refer to the table below for pin definitions.

NMI Button Pin Definitions (JF1)	
Pins	Definition
19	Control
20	Ground

4.5 Jumpers

Explanation of Jumpers

To modify the operation of the motherboard, jumpers are used to choose between optional settings. Jumpers create shorts between two pins to change the function associated with it. Pin 1 is identified with a square solder pad on the printed circuit board. See the motherboard layout page for jumper locations.

Note: On a two-pin jumper, "Closed" means the jumper is on both pins and "Open" indicates the jumper is either on only one pin or has been completely removed.

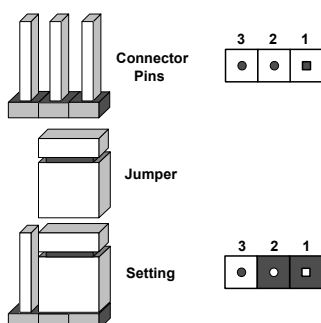

CMOS Clear

JBT1 is used to clear CMOS, which will also clear any passwords. Instead of pins, this jumper consists of contact pads to prevent accidentally clearing the contents of CMOS.

To Clear CMOS

1. First power down the system and unplug the power cord(s).
2. Remove the cover of the chassis to access the motherboard.
3. Remove the onboard battery from the motherboard.
4. Short the CMOS pads with a metal object such as a small screwdriver for at least four seconds.
5. Remove the screwdriver (or shorting device).
6. Replace the cover, reconnect the power cord(s) and power on the system.

Notes: Clearing CMOS will also clear all passwords.

Do not use the PW_ON connector to clear CMOS.



Watch Dog

JWD1 controls the Watch Dog function. Watch Dog is a monitor that can reboot the system when a software application hangs. Jumping pins 1-2 will cause Watch Dog to reset the system if an application hangs. Jumping pins 2-3 will generate a non-maskable interrupt signal for the application that hangs. Watch Dog must also be enabled in BIOS. The default setting is Reset.

Note: When Watch Dog is enabled, the user needs to write their own application software to disable it.

Watch Dog Jumper Settings	
Jumper Setting	Definition
Pins 1-2	Reset
Pins 2-3	NMI
Open	Disabled

Manufacturing Mode Select

Close JPME2 to bypass SPI flash security and force the system to use the Manufacturing Mode, which will allow you to flash the system firmware from a host server to modify system settings. See the table below for jumper settings.

Manufacturing Mode Select Jumper Settings	
Jumper Setting	Definition
Pins 1-2	Normal (Default)
Pins 2-3	Manufacturing Mode

I2C Bus for VRM

Jumpers JVRM_SEL1 allows the BMC or the PCH to access CPU and memory VRM controllers. See the table below for jumper settings.

VRM Jumper Settings	
Jumper Setting	Definition
Pins 1-2	BMC (Normal)
Pins 2-3	PCH

4.6 LED Indicators

Dedicated IPMI LAN LEDs

A dedicated IPMI LAN is located on the I/O Backplane of the motherboard. The amber LED on the right indicates activity, while the green LED on the left indicates the speed of the connection. See the tables below for more information.

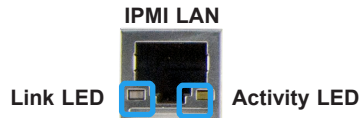

IPMI LAN Connection LED	
LED Color	Definition
Off	No Connection, 10 Mbps or 100 Mbps
Green	10 Gbps
Amber	1 Gbps

IPMI LAN Activity LED		
LED	Color/State	Definition
Link (left)	Green: Solid	100 Mbps
Activity (Right)	Amber: Blinking	Active

BMC Heartbeat LED

LEDBMC is the BMC heartbeat LED. When the LED is blinking green, BMC is functioning normally. See the table below for the LED status.

BMC Heartbeat LED Indicator	
LED Color	Definition
Green: Blinking	BMC Normal

Onboard Power LED

The Onboard Power LED is located at LEDPWR on the motherboard. When this LED is on, the system is on. Be sure to turn off the system and unplug the power cord before removing or installing components. Refer to the table below for more information.

Onboard Power LED Indicator	
LED Color	Definition
Off	System Off (power cable not connected)
Green	System On

Unit ID LED

A rear UID LED indicator (UID-LED) is located near the UID switch on the I/O back panel. This UID indicator provides easy identification of a system unit that may need service.

UID LED LED Indicator	
LED Color	Definition
Blue: On	Unit Identified

HDD LED

An HDD LED indicator, located at HDD_LED1 on the motherboard, indicates the status of onboard hard drive disks including SATA devices. When HDD_LED1 is blinking, all onboard HDDs are functioning normally. See the table below for more information.

HDD LED LED Indicator	
LED Color	Definition
Green: Blinking	HDDs: Normal

Onboard Memory_Fault LED Indicators

The memory-fault LED indicators are located at P1_LED_A1 - P2_LED_F2 on the motherboard. Each memory LED indicates the status of the DIMM module installed on the memory slot that carries the same name. For example, if P1_LED_A1 is on, it indicates that an error has occurred to the DIMM module installed on the P1-DIMMA1 memory slot. See the tables below for more information.

Memory-Fault LED Indicators & Corresponding Memory Modules	
LED Indicator	Corresponding DIMM Module
P1_LED_A1 / P1_LED_A2	P1-DIMMA1 / P1-DIMMA2
P1_LED_B1 / P1_LED_B2	P1-DIMMB1 / P1-DIMMB2
P1_LED_C1 / P1_LED_C2	P1-DIMMC1 / P1-DIMMC2
P1_LED_D1 / P1_LED_D2	P1-DIMMD1 / P1-DIMMD2
P1_LED_E1 / P1_LED_E2	P1-DIMME1 / P1-DIMME2
P1_LED_F1 / P1_LED_F2	P1-DIMMF1 / P1-DIMMF2
P2_LED_A1 / P2_LED_A2	P2-DIMMA1 / P2-DIMMA2
P2_LED_B1 / P2_LED_B2	P2-DIMMB1 / P2-DIMMB2
P2_LED_C1 / P2_LED_C2	P2-DIMMC1 / P2-DIMMC2
P2_LED_D1 / P2_LED_D2	P2-DIMMD1 / P2-DIMMD2
P2_LED_E1 / P2_LED_E2	P2-DIMME1 / P2-DIMME2
P2_LED_F1 / P2_LED_F2	P2-DIMMF1 / P2-DIMMF2

Memory-Fault LED LED Indicator	
LED Color	Definition
LED On: Red	Corresponding DIMM Module: Bad

Chapter 5

Software

After the hardware has been installed, you can install the Operating System (OS), configure RAID settings and install the drivers.

5.1 Microsoft Windows OS Installation

If you will be using RAID, you must configure RAID settings before installing the Windows OS and the RAID driver. Refer to the RAID Configuration User Guides posted on our website at www.supermicro.com/support/manuals.

Installing the OS

1. Create a method to access the MS Windows installation ISO file. That might be a DVD, perhaps using an external USB/SATA DVD drive, or a USB flash drive, or the IPMI KVM console.
2. Retrieve the proper RST/RSTe driver. Go to the Supermicro web page for your motherboard and click on "Download the Latest Drivers and Utilities", select the proper driver, and copy it to a USB flash drive.
3. Boot from a bootable device with Windows OS installation. You can see a bootable device list by pressing **F11** during the system startup.

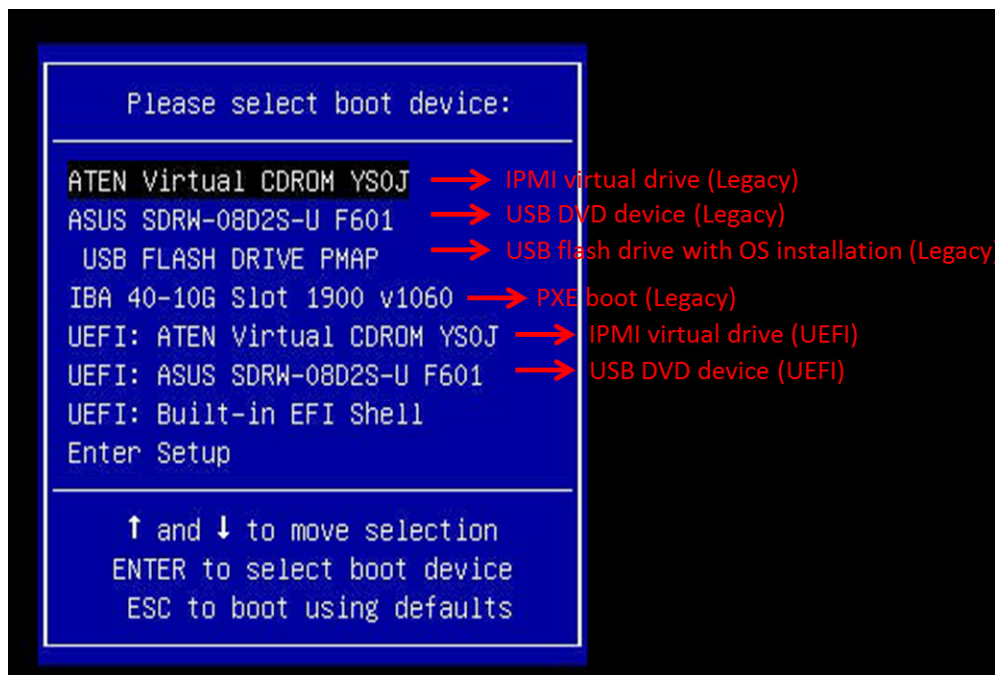

Figure 5-1. Select Boot Device

4. During Windows Setup, continue to the dialog where you select the drives on which to install Windows. If the disk you want to use is not listed, click on “Load driver” link at the bottom left corner.

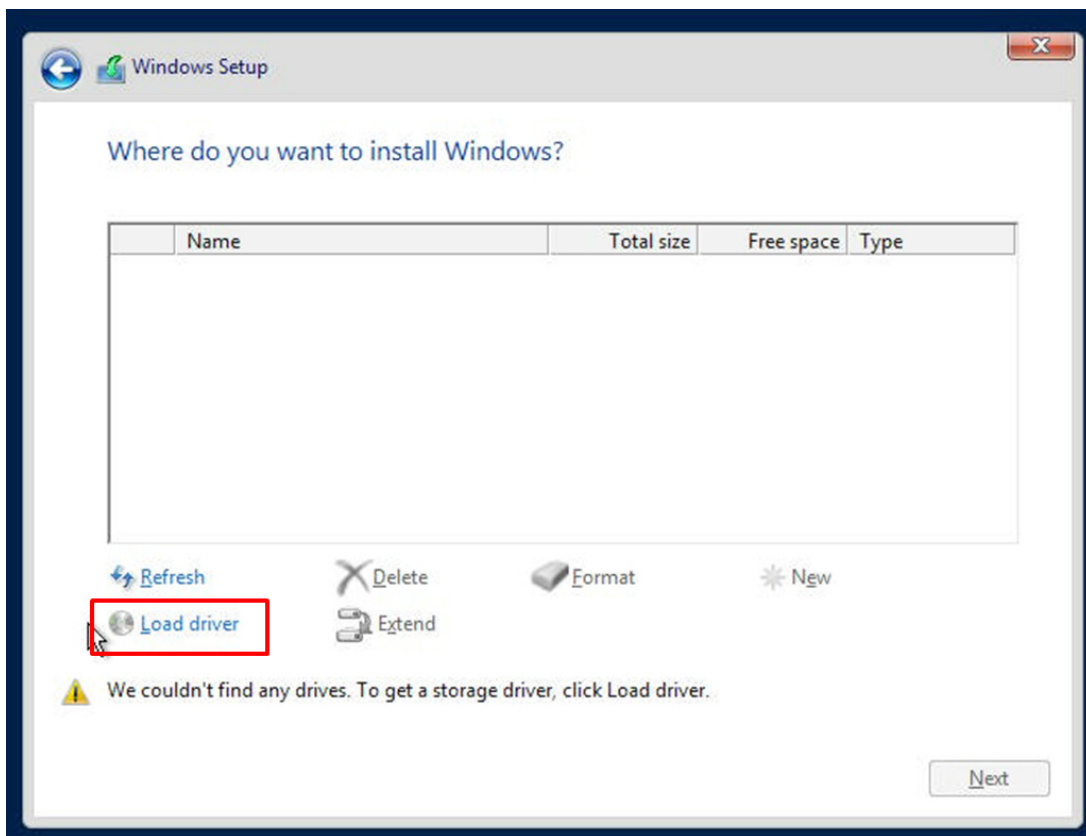

Figure 5-2. Load Driver Link

To load the driver, browse the USB flash drive for the proper driver files.

- For RAID, choose the SATA/sSATA RAID driver indicated then choose the storage drive on which you want to install it.
 - For non-RAID, choose the SATA/sSATA AHCI driver indicated then choose the storage drive on which you want to install it.
5. Once all devices are specified, continue with the installation.
 6. After the Windows OS installation has completed, the system will automatically reboot multiple times.

5.2 Driver Installation

The Supermicro website contains drivers and utilities for your system at <https://www.supermicro.com/wftp/driver>. Some of these must be installed, such as the chipset driver.

After accessing the website, go into the CDR_Images (in the parent directory of the above link) and locate the ISO file for your motherboard. Download this file to to a USB flash drive or a DVD. (You may also use a utility to extract the ISO file if preferred.)

Another option is to go to the Supermicro website at <http://www.supermicro.com/products/>. Find the product page for your motherboard, and "Download the Latest Drivers and Utilities".

Insert the flash drive or disk and the screenshot shown below should appear.

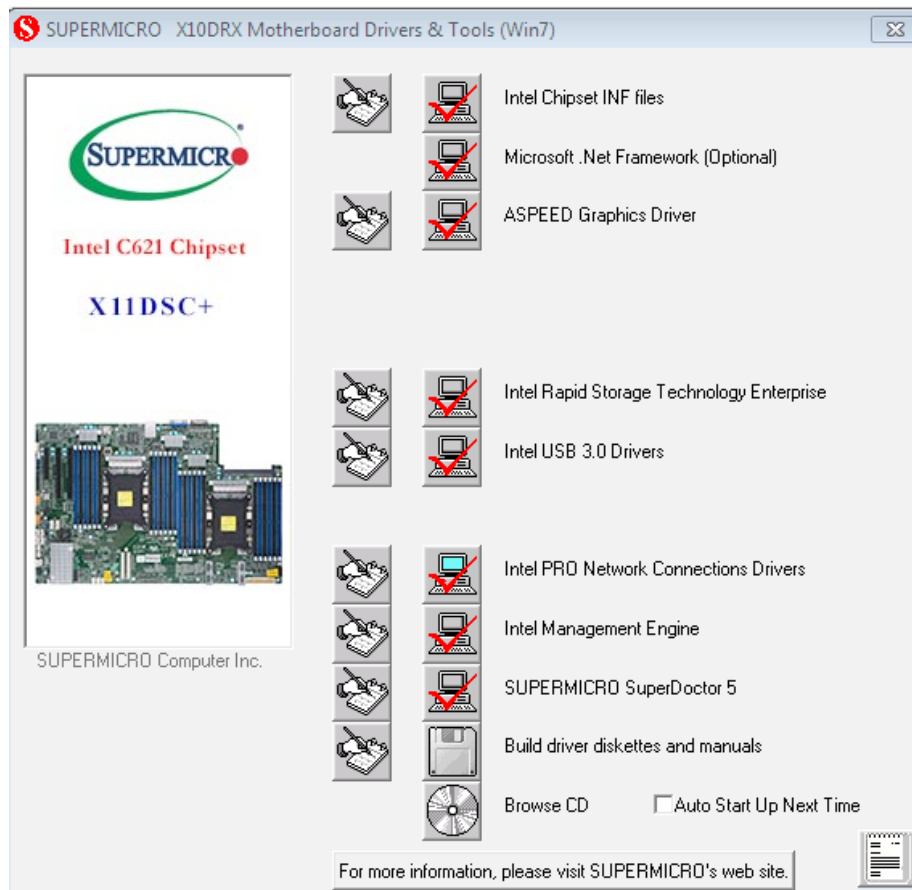

Figure 5-3. Driver & Tool Installation Screen

Note: Click the icons showing a hand writing on paper to view the readme files for each item. Click the computer icons to the right of these items to install each item (from top to the bottom) one at a time. **After installing each item, you must re-boot the system before moving on to the next item on the list.** The bottom icon with a CD on it allows you to view the entire contents.

5.3 SuperDoctor® 5

The Supermicro SuperDoctor 5 is a program that functions in a command-line or web-based interface for Windows and Linux operating systems. The program monitors such system health information as CPU temperature, system voltages, system power consumption, fan speed, and provides alerts via email or Simple Network Management Protocol (SNMP).

SuperDoctor 5 comes in local and remote management versions and can be used with Nagios to maximize your system monitoring needs. With SuperDoctor 5 Management Server (SSM Server), you can remotely control power on/off and reset chassis intrusion for multiple systems with SuperDoctor 5 or IPMI. SuperDoctor 5 Management Server monitors HTTP, FTP, and SMTP services to optimize the efficiency of your operation.

Note: The default User Name and Password for SuperDoctor 5 is ADMIN / ADMIN.

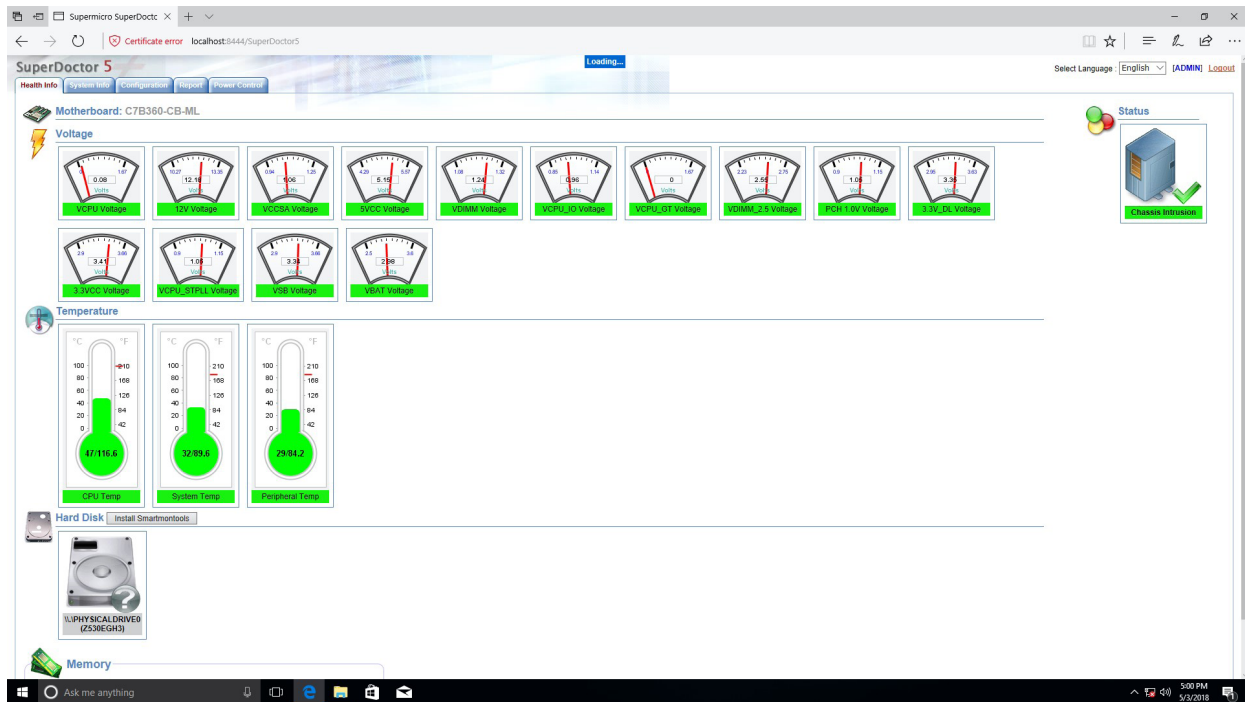

Figure 5-4. SuperDoctor 5 Interface Display Screen (Health Information)

5.4 IPMI

The X11DSC+ supports the Intelligent Platform Management Interface (IPMI). IPMI is used to provide remote access, monitoring and management. There are several BIOS settings that are related to IPMI.

Supermicro ships standard products with a unique password for the BMC ADMIN user. This password can be found on a label on the motherboard. For general documentation and information on IPMI, please visit our website at: <http://www.supermicro.com/products/nfo/IPMI.cfm>.

Chapter 6

UEFI BIOS

6.1 Introduction

This chapter describes the AMIBIOS™ Setup utility for the X11DSC+ motherboard(s). The BIOS is stored on a chip and can be easily upgraded using a flash program.

Note: Due to periodic changes to the BIOS, some settings may have been added or deleted and might not yet be recorded in this manual. Please refer to the Manual Download area of our website for any changes to BIOS that may not be reflected in this manual.

Starting the Setup Utility

To enter the BIOS Setup Utility, hit the <Delete> key while the system is booting-up. (In most cases, the <Delete> key is used to invoke the BIOS setup screen. There are a few cases when other keys are used, such as <F1>, <F2>, etc.) Each main BIOS menu option is described in this manual.

The Main BIOS screen has two main frames. The left frame displays all the options that can be configured. "Grayed-out" options cannot be configured. The right frame displays the key legend. Above the key legend is an area reserved for a text message. When an option is selected in the left frame, it is highlighted in white. Often a text message will accompany it. (Note that BIOS has default text messages built in. We retain the option to include, omit, or change any of these text messages.) Settings printed in **Bold** are the default values.

A " ►" indicates a submenu. Highlighting such an item and pressing the <Enter> key will open the list of settings within that submenu.

The BIOS setup utility uses a key-based navigation system called hot keys. Most of these hot keys (<F1>, <F10>, <Enter>, <ESC>, <Arrow> keys, etc.) can be used at any time during the setup navigation process.

6.2 Main Menu

When you first enter the AMI BIOS setup utility, you will enter the Main setup screen. You can always return to the Main setup screen by selecting the Main tab on the top of the screen. The Main BIOS setup screen is shown below. The following Main menu items will be displayed:

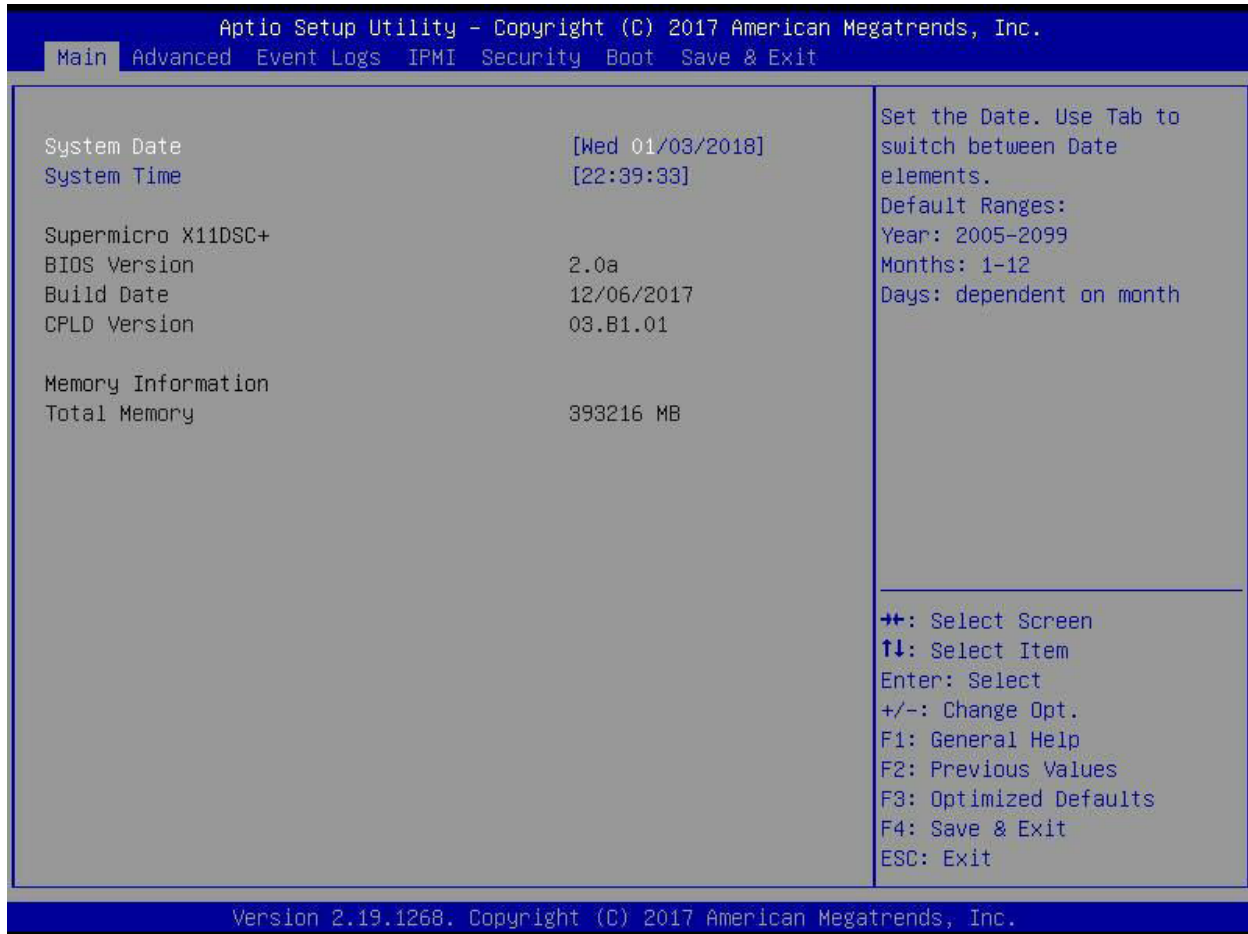

System Date/System Time

Use this item to change the system date and time. Highlight System Date or System Time using the arrow keys. Enter new values using the keyboard. Press the <Tab> key or the arrow keys to move between fields. The date must be entered in Day MM/DD/YYYY format. The time is entered in HH:MM:SS format.

Note: The time is in the 24-hour format. For example, 5:30 P.M. appears as 17:30:00. The date's default value is 01/01/2014 after RTC reset.

Supermicro X11DSC+

BIOS Version

This item displays the version of the BIOS ROM used in the system.

Build Date

This item displays the date when the version of the BIOS ROM used in the system was built.

CPLD Version

This item displays the version of the CPLD (Complex-Programmable Logical Device) used in the system.

Memory Information**Total Memory**

This item displays the total size of memory available in the system.

Memory Speed

This item displays the default speed of the memory modules installed in the system.

6.3 Advanced Settings Menu

Use the arrow keys to select the Advanced submenu and press <Enter> to access the submenu items:

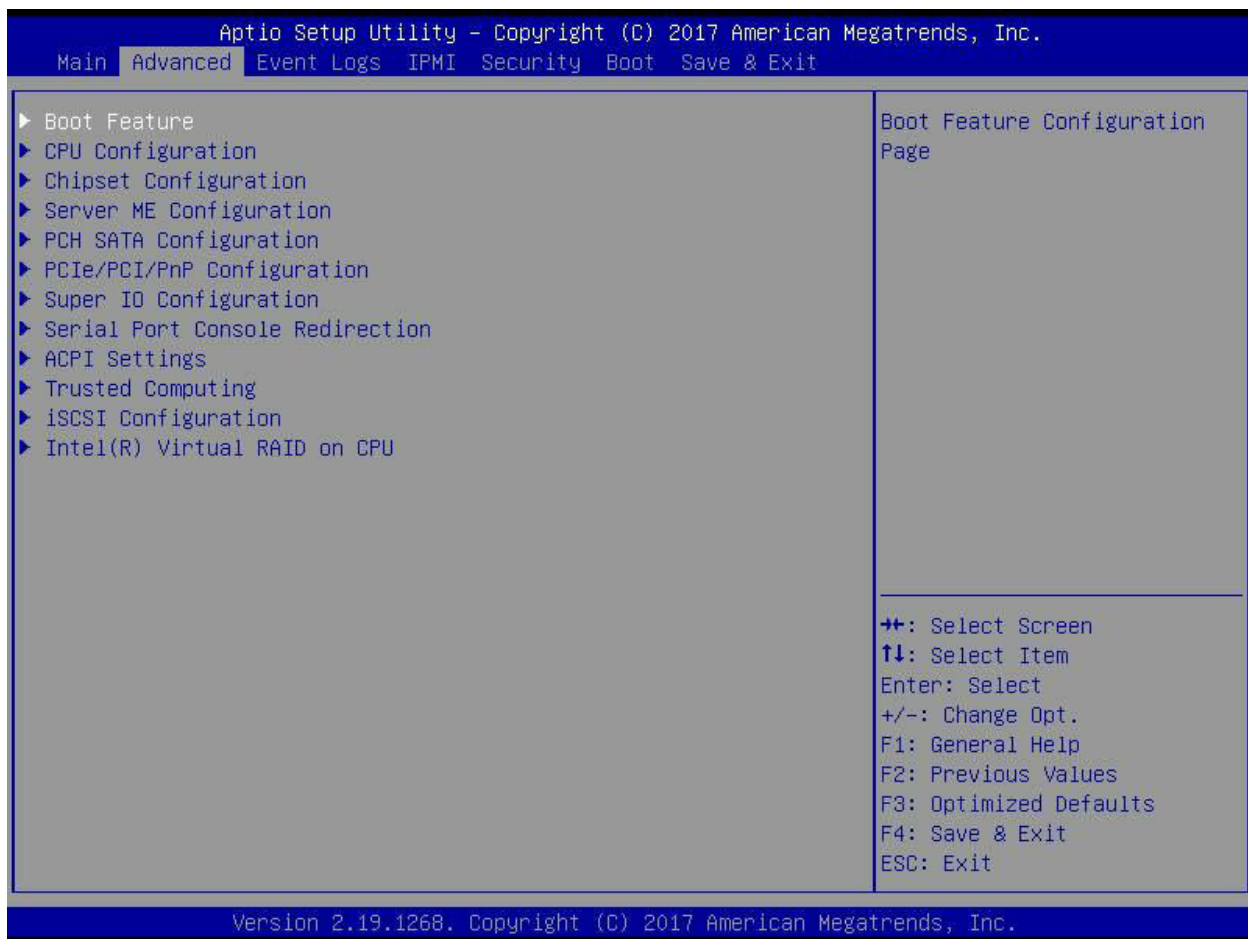

Warning: Take Caution when changing the Advanced settings. An incorrect value, an incorrect DRAM frequency, or an incorrect BIOS timing setting may cause the system to malfunction. When this occurs, restore the setting to the manufacture default setting.

► Boot Feature

Quiet Boot

Use this feature to select the screen between displaying POST messages or the OEM logo at bootup. Select Disabled to display the POST messages. Select Enabled to display the OEM logo instead of the normal POST messages. The options are Disabled and **Enabled**.

Note: POST message is always displayed regardless of the item setting.

Option ROM Messages

Use this feature to set the display mode for the Option ROM. Select Keep Current to display the current AddOn ROM setting. Select Force BIOS to use the Option ROM display set by the system BIOS. The options are **Force BIOS** and Keep Current.

Bootup NumLock State

Use this feature to set the Power-on state for the <Numlock> key. The options are **On** and Off.

Wait For "F1" If Error

Use this feature to force the system to wait until the 'F1' key is pressed if an error occurs. The options are **Disabled** and Enabled.

INT19 Trap Response

Interrupt 19 is the software interrupt that handles the boot disk function. When this item is set to Immediate, the ROM BIOS of the host adaptors will "capture" Interrupt 19 at bootup immediately and allow the drives that are attached to these host adaptors to function as bootable disks. If this item is set to Postponed, the ROM BIOS of the host adaptors will not capture Interrupt 19 immediately and allow the drives attached to these adaptors to function as bootable devices at bootup. The options are **Immediate** and Postponed.

Re-try Boot

If this item is enabled, the BIOS will automatically reboot the system from a specified boot device after its initial boot failure. The options are **Disabled**, Legacy Boot, and EFI Boot.

Install Windows 7 USB support

Enable this feature to use the USB keyboard and mouse during the Windows 7 installation, since the native XHCI driver support is unavailable. Use a SATA optical drive as a USB drive. USB CD/DVD drives are not supported. Disable this feature after the XHCI driver has been installed in Windows. The options are **Disabled** and Enabled.

Port 61h Bit-4 Emulation

Select Enabled to support the emulation of Port 61h bit-4 toggling in SMM (System Management Mode). The options are **Disabled** and Enabled.

Power Configuration

Watch Dog Function

If enabled, the Watch Dog Timer will allow the system to reset or generate NMI based on jumper settings when it is expired for more than 5 minutes. The options are **Disabled** and **Enabled**.

Restore on AC Power Loss

Use this feature to set the power state after a power outage. Select Stay-Off for the system power to remain off after a power loss. Select Power-On for the system power to be turned on after a power loss. Select Last State to allow the system to resume its last power state before a power loss. The options are Stay Off, Power On, and **Last State**.

Power Button Function

This feature controls how the system shuts down when the power button is pressed. Select 4 Seconds Override for the user to power off the system after pressing and holding the power button for 4 seconds or longer. Select Instant Off to instantly power off the system as soon as the user presses the power button. The options are **Instant Off** and 4 Seconds Override.

Throttle on Power Fail

Throttling improves reliability and reduces power consumption in the processor via automatic voltage control during processor idle states. Select Enabled to decrease the system power by throttling CPU frequency when one power supply is failed. The options are **Disabled** and **Enabled**.

► CPU Configuration

Warning: Setting the wrong values in the following sections may cause the system to malfunction.

Processor Configuration

The following CPU information will be displayed:

- Processor BSP Revision
- Processor Socket
- Processor ID
- Processor Frequency
- Processor Max Ration

- Processor Min Ration
- Microcode Revision
- L1 Cache RAM
- L2 Cache RAM
- L3 Cache RAM
- Processor 0 Version
- Processor 1 Version

Hyper-Threading [All] (Available when supported by the CPU)

Select Enabled to support Intel® Hyper-threading Technology to enhance CPU performance. The options are Disable and **Enable**.

Cores Enabled

This feature allows the user to determine the number of CPU cores to be enabled. Enter "0" to enable all cores. The default setting is 0, which enables all CPU cores in the system.

Execute Disable Bit (Available if supported by the OS & the CPU)

Select Enable to enable the Execute-Disable Bit which will allow the processor to designate areas in the system memory where an application code can execute and where it cannot, thus preventing a worm or a virus from flooding illegal codes to overwhelm the processor or damage the system during an attack. (Please refer to Intel's website for more information.) The options are Disable and **Enable**.

Intel Virtualization Technology (Available when supported by the CPU)

Select Enable to use Intel® Virtualization Technology so that I/O device assignments will be reported directly to the VMM (Virtual Memory Management) through the DMAR ACPI Tables. This feature offers fully-protected I/O resource-sharing across the Intel® platforms, providing the user with greater reliability, security and availability in networking and data-sharing. The options are Disable and **Enable**.

Note: If a change is made to this setting, you will need to reboot the system for the change to take effect. Refer to Intel's website for detailed information.

PPIN Control

Select Unlock/Enable to use the Protected-Processor Inventory Number (PPIN) in the system. The options are Unlock/Disable and **Unlock/Enable**.

Hardware Prefetcher (Available when supported by the CPU)

If this item is set to Enable, the hardware prefetcher will prefetch streams of data and instructions from the main memory to the L2 cache to improve CPU performance. The options are **Enable** and Disable.

Adjacent Cache Prefetch (Available when supported by the CPU)

The CPU prefetches the cache line for 64 bytes if this feature is set to Disable. The CPU prefetches both cache lines for 128 bytes as comprised if this feature is set to **Enable**. The options are **Enable** and Disable.

DCU Streamer Prefetcher (Available when supported by the CPU)

Select Enabled to enable Intel® CPU Advanced Encryption Standard (AES) Instructions for CPU to enhance data integrity. The options are **Enable** and Disable.

DCU IP Prefetcher (Available when supported by the CPU)

If this feature is set to Enable, the DCU (Data Cache Unit) IP prefetcher will prefetch IP addresses in advance to improve network connectivity and system performance. The options are **Enable** and Disable.

LLC Prefetch

Select Enable to support the LLC prefetch on all threads. The options are **Disable** and Enable.

Extended APIC

Select Enable to use the extended APIC (Advanced Programmable Interrupt Control) support to enhance power management. The options are **Disable** and Enable.

AES-NI

Select Enable to use the Intel® Advanced Encryption Standard (AES) New Instructions (NI) to ensure data security. The options are Disable and **Enable**.

► Advanced Power Management Configuration

Power Technology

Use this item to enable power management features. The options are Disable, **Energy Efficient**, and Custom. Select Energy Efficient to support power-saving mode. Select Custom to customize system power settings. Select Disable to disable power-saving settings.

Power Performance Tuning (Available when Power Technology is set to Custom)

This feature allows the user to set whether the operating system or the BIOS controls the Energy Performance BIAS (EPB). The options are **OS Controls EPB** and BIOS Controls EPB.

ENERGY_PERF_BIAS_CFG Mode (Available when Power Performance Tuning is set to BIOS Controls EPB)

The Energy Performance BIAS (EPB) feature allows the user to configure CPU power and performance settings. Select Maximum Performance to set the highest performance. Select Performance to optimize performance over energy efficiency. Select Balanced Performance to prioritize performance optimization while conserving energy. Select Balanced Power to prioritize energy conservation while maintaining good performance. Select Power to optimize energy efficiency over performance. The options are Maximum Performance, Performance, **Balanced Performance**, Balanced Power, and Power.

► CPU P State Control (Available when Power Technology is set to Custom)**SpeedStep (Pstates)**

EIST (Enhanced Intel® SpeedStep™ Technology) allows the system to automatically adjust processor voltage and core frequency to reduce power consumption and heat dissipation. The options are Disable and **Enable**.

EIST PSD Function

This feature allows the user to change the P-State (Power-Performance State) coordination type. P-State is also known as "SpeedStep" for Intel® processors. Select HW_ALL to change the P-State coordination type for all hardware components only. Select SW_ALL to change the P-State coordination type for all software installed in the system. Select SW_ANY to change the P-State coordination type for a particular software program specified by the user in the system. The options are **HW_ALL**, SW_ALL, and SW_ANY.

Turbo Mode (Available when Intel® EIST Technology is enabled)

Select Enable to use the Turbo Mode to boost system performance. The options are Disable and **Enable**.

► Hardware PM State Control (Available when Power Technology is set to Custom)**Hardware P-States**

This feature enables the hardware P-States support. The options are **Disable**, Native Mode, Out of Band Mode, and Native Mode with No Legacy Support.

► **CPU C State Control (Available when Power Technology is set to Custom)**

Autonomous Core C-State

Use this feature to enable the autonomous core C-State control. The options are **Disable** and **Enable**.

CPU C6 report

Select **Enable** to allow the BIOS to report the CPU C6 State (ACPI C3) to the operating system. During the CPU C6 State, the power to all cache is turned off. The options are **Disable**, **Enable**, and **Auto**.

Enhanced Halt State (C1E)

Select **Enable** to use Enhanced Halt-State technology, which will significantly reduce the CPU's power consumption by reducing the CPU's clock cycle and voltage during a Halt-state. The options are **Disable** and **Enable**.

► **Package C State Control (Available when Power Technology is set to Custom)**

Package C State

This feature allows the user to set the limit on the C-State package register. The options are **C0/C1 state**, **C2 state**, **C6 (non Retention) state**, **C6 (Retention) state**, **No Limit**, and **Auto**.

► **CPU T State Control (Available when Power Technology is set to Custom)**

Software Controlled T-States

This feature enables the software controlled T-States support. The options are **Disable** and **Enable**.

► Chipset Configuration

Warning: Setting the wrong values in the following features may cause the system to malfunction.

► North Bridge

This feature allows the user to configure the settings for the Intel® North Bridge.

► UPI Configuration

UPI Configuration

This section displays the following UPI General Configuration information:

- Number of CPU
- Number of Active UPI Link
- Current UPI Link Speed
- Current UPI Link Frequency
- UPI Global MMIO Low Base/Limit
- UPI Global MMIO High Base/Limit
- UPI Pci-e Configuration Base/Size

Degrade Precedence

Select **Topology Precedence** to degrade features if system options are in conflict. Select **Feature Precedence** to degrade topology if system options are in conflict. The options are **Topology Precedence** and **Feature Precedence**.

Link L0p Enable

Select **Enable** for the QPI to enter the L0p state for power saving. The options are **Disable**, **Enable**, and **Auto**.

Link L1 Enable

Select Enable for the QPI to enter the L1 state for power saving. The options are Disable, Enable, and **Auto**.

IO Directory Cache (IODC)

Use this feature to enable the IO Directory Cache (IODC) support. The options are Disable, Auto, Enable for Remote InvItom Hybrid Push, InvItom AllocFlow, Enable for Remote InvItom Hybrid AllocNonAlloc, and Enable for Remote InvItom and Remote WViLF.

SNC

Sub NUMA Clustering (SNC) is a feature that breaks up the Last Level Cache (LLC) into clusters based on address range. Each cluster is connected to a subset of the memory controller. Enabling SNC improves average latency and reduces memory access congestion to achieve higher performance. Select Auto for 1-cluster or 2-clusters depending on IMC interleave. Select Enable for Full SNC (2-clusters and 1-way IMC interleave). The options are Disable, Enable, and Auto.

XPT Prefetch

XPT Prefetch is a feature that speculatively makes a copy to the memory controller of a read request being sent to the LLC. If the read request maps to the local memory address and the recent memory reads are likely to miss the LLC, a speculative read is sent to the local memory controller. The options are **Disable** and Enable.

KTI Prefetch

KTI Prefetch is a feature that enables memory read to start early on a DDR bus, where the KTI Rx path will directly create a Memory Speculative Read command to the memory controller. The options are Disable and **Enable**.

Local/Remote Threshold

This feature allows the user to set the threshold for the Interrupt Request (IRQ) signal, which handles hardware interruptions. The options are Disable, **Auto**, Low, Medium, and High.

Stale AtoS

This feature optimizes A to S directory. When all snoop responses found in directory A are found to be Rspl, then all data is moved to directory S and is returned in S-state. The options are **Disable**, Enable, and Auto.

LLC Dead Line Alloc

Select Enable to optimally fill dead lines in LLC. Select Disable to never fill dead lines in LLC. The options are Disable, **Enable**, and Auto.

Isoc Mode

Select Enable to enable Isochronous support to meet QoS (Quality of Service) requirements. This feature is especially important for Virtualization Technology. The options are Disable, Enable, and **Auto**.

► Memory Configuration**Integrated Memory Controller (iMC)****Enforce POR**

Select Enable to enforce POR restrictions on DDR4 frequency and voltage programming. The options are **POR** and Disable.

Memory Frequency

Use this feature to set the maximum memory frequency for onboard memory modules. The options are **Auto**, 1866, 2000, 2133, 2400, and 2666.

Data Scrambling for NVMDIMM

Select Enable to enable data scrambling to enhance system performance and data integrity. The options are **Auto**, Disable, and Enable.

Data Scrambling for DDR4

Use this feature to enable data scrambling for DDR4. The options are **Auto**, Disable, and Enable.

tCCD_L Relaxation

Select Auto to get TCDD settings from SPD (Serial Presence Detect) and implement into memory RC code to improve system reliability. Select Disable for TCCD to follow Intel® POR. The options are Disable and **Auto**.

Memory tRWSR Relaxation

Select Enable to use the same tRWSR DDR timing setting among all memory channels, in which case, the worst case value among all channels will be used. Select Disable to

use different values for the tRWSR DDR timing settings for different channels as trained. The options are Disable and **Enable**.

2X Refresh Options

Use this item to select the 2X refresh mode. The options are **Auto** and Enable.

Page Policy

This feature allows the user to determine the desired page mode for IMC. When Auto is selected, the memory controller will close or open pages based on the current operation. Closed policy closes that page after reading or writing. Adaptive is similar to open page policy, but can be dynamically modified. The options are **Auto**, Closed, and Adaptive..

IMC Interleaving

This feature allows the user to configure Integrated Memory Controller (IMC) Interleaving settings. The options are **Auto**, 1-way Interleave, and 2-way Interleave.

►Memory Topology

The item displays the information of onboard memory modules as detected by the BIOS.

►Memory RAS (Reliability_Availability_Serviceability) Configuration

Memory RAS Configuration Setup

Use this submenu to configure the following Memory RAS settings.

Static Virtual Lockstep Mode

Select Enable to support the static virtual lockstep mode. The options are **Disable** and Enable.

Mirror Mode

Use this item to select the mirror mode. The options are **Disable**, Mirror Mode 1LM, and Mirror Mode 2LM. If this item is set to Mirror Mode 1LM or Mirror Mode 2LM, the available memory capacity will be reduced by 50 percent.

UEFI ARM Mirror

Select Enable to support the UEFI-based address range mirroring with setup option. The options are **Disable** and Enable.

Memory Rank Sparing

Select Enable to enable memory-sparing support for memory ranks to improve memory performance. The options are **Disable** and Enable.

**If the item above "Memory Rank Sparing" is set to Enable, the following item, "Multi Rank Sparing", will be available:*

Multi Rank Sparing

Use this feature to set the multiple rank sparing number. The default setting and the maximum is two ranks per channel. The options are One Rank and **Two Rank**.

Correctable Error Threshold

Use this item to enter the threshold value for correctable memory errors. The default setting is **10**.

Run Sure

Use this item to enable the Intel® Run Sure Technology. The options are **Disable** and Enable.

Patrol Scrub

Patrol Scrubbing is a process that allows the CPU to correct correctable memory errors detected on a memory module and send the correction to the requestor (the original source). When this item is set to Enable, read-and-write will be performed every 16K cycles per cache line if there is no delay caused by internal processing. The options are Disable and **Enable**.

Patrol Scrub Interval

This feature allows you to decide how many hours the system should wait before the next complete patrol scrub is performed. Use the keyboard to enter a value from 0-24. The Default setting is **24**.

► IIO Configuration

IIO Configuration

EV DFX Features

When this feature is set to Enable, the EV_DFX Lock Bits that are located on a processor will always remain clear during electric tuning. The options are **Disable** and Enable.

► CPU1 Configuration

IOU0 (IIO PCIe Br1)

This item configures the PCI-E port Bifurcation setting for a PCI-E port specified by the user. The options are x4x4x4x4, x4x4x8, x8x4x4, **x8x8**, x16, and Auto.

IOU1 (IIO PCIe Br2)

This item configures the PCI-E port Bifurcation setting for a PCI-E port specified by the user. The options are x4x4x4x4, x4x4x8, x8x4x4, x8x8, x16, and **Auto**.

IOU2 (IIO PCIe Br3)

This item configures the PCI-E port Bifurcation setting for a PCI-E port specified by the user. The options are x4x4x4x4, x4x4x8, x8x4x4, x8x8, x16, and **Auto**.

► P1_NVMe0

Link Speed

Use this feature to select the link speed for the PCIe port. The options are **Auto**, Gen 1 (2.5 GT/s), Gen 2 (5 GT/s), and Gen 3 (8 GT/s).

PCI-E Port Link Status

PCI-E Port Link Max

PCI-E Port Link Speed

PCI-E Port Clocking

The options are Distinct and **Common**. If this item is set to Distinct, this component and the component at the opposite end of the Link are operating with separate reference clock sources. If this item is set to Common, this component and the component at the opposite end of the Link are operating with a common clock source.

PCI-E Port Max Payload Size

Select Auto for the system BIOS to automatically set the maximum payload value for a PCI-E device to enhance system performance. The options are 128B, 256B, and **Auto**.

►P1_NVMe2**Link Speed**

Use this feature to select the link speed for the PCIe port. The options are **Auto**, Gen 1 (2.5 GT/s), Gen 2 (5 GT/s), and Gen 3 (8 GT/s).

PCI-E Port Link Status**PCI-E Port Link Max****PCI-E Port Link Speed****PCI-E Port Clocking**

The options are Distinct and **Common**. If this item is set to Distinct, this component and the component at the opposite end of the Link are operating with separate reference clock sources. If this item is set to Common, this component and the component at the opposite end of the Link are operating with a common clock source.

PCI-E Port Max Payload Size

Select Auto for the system BIOS to automatically set the maximum payload value for a PCI-E device to enhance system performance. The options are 128B, 256B, and **Auto**.

►CPU1 JMEZZ1 PCI-E 3.0 x8**Link Speed**

Use this feature to select the link speed for the PCIe port. The options are **Auto**, Gen 1 (2.5 GT/s), Gen 2 (5 GT/s), and Gen 3 (8 GT/s).

PCI-E Port Link Status**PCI-E Port Link Max****PCI-E Port Link Speed****PCI-E Port Clocking**

The options are Distinct and **Common**. If this item is set to Distinct, this component and the component at the opposite end of the Link are operating with separate reference clock sources. If this item is set to Common, this component and the component at the opposite end of the Link are operating with a common clock source.

PCI-E Port Max Payload Size

Select Auto for the system BIOS to automatically set the maximum payload value for a PCI-E device to enhance system performance. The options are 128B, 256B, and **Auto**.

► CPU2 Configuration

IOU0 (IIO PCIe Br1)

This item configures the PCI-E port Bifuraction setting for a PCI-E port specified by the user. The options are x4x4x4x4, x4x4x8, x8x4x4, x8x8, x16, and **Auto**.

IOU1 (IIO PCIe Br2)

This item configures the PCI-E port Bifuraction setting for a PCI-E port specified by the user. The options are x4x4x4x4, x4x4x8, x8x4x4, x8x8, x16, and **Auto**.

IOU2 (IIO PCIe Br3)

This item configures the PCI-E port Bifuraction setting for a PCI-E port specified by the user. The options are x4x4x4x4, x4x4x8, x8x4x4, **x8x8**, x16, and Auto.

► CPU2 SLOT1 PCI-E 3.0 x8

Link Speed

Use this feature to select the link speed for the PCIe port. The options are **Auto**, Gen 1 (2.5 GT/s), Gen 2 (5 GT/s), and Gen 3 (8 GT/s).

PCI-E Port Link Status

PCI-E Port Link Max

PCI-E Port Link Speed

PCI-E Port Clocking

The options are Distinct and **Common**. If this item is set to Distinct, this component and the component at the opposite end of the Link are operating with separate reference clock sources. If this item is set to Common, this component and the component at the opposite end of the Link are operating with a common clock source.

PCI-E Port Max Payload Size

Select Auto for the system BIOS to automatically set the maximum payload value for a PCI-E device to enhance system performance. The options are 128B, 256B, and **Auto**.

► CPU2 SLOT3 PCI-E 3.0 x16**Link Speed**

Use this feature to select the link speed for the PCIe port. The options are **Auto**, Gen 1 (2.5 GT/s), Gen 2 (5 GT/s), and Gen 3 (8 GT/s).

PCI-E Port Link Status**PCI-E Port Link Max****PCI-E Port Link Speed****PCI-E Port Clocking**

The options are Distinct and **Common**. If this item is set to Distinct, this component and the component at the opposite end of the Link are operating with separate reference clock sources. If this item is set to Common, this component and the component at the opposite end of the Link are operating with a common clock source.

PCI-E Port Max Payload Size

Select Auto for the system BIOS to automatically set the maximum payload value for a PCI-E device to enhance system performance. The options are 128B, 256B, and **Auto**.

► CPU2 SLOT2 PCI-E 3.0 x16**Link Speed**

Use this feature to select the link speed for the PCIe port. The options are **Auto**, Gen 1 (2.5 GT/s), Gen 2 (5 GT/s), and Gen 3 (8 GT/s).

PCI-E Port Link Status

PCI-E Port Link Max

PCI-E Port Link Speed

PCI-E Port Clocking

The options are Distinct and **Common**. If this item is set to Distinct, this component and the component at the opposite end of the Link are operating with separate reference clock sources. If this item is set to Common, this component and the component at the opposite end of the Link are operating with a common clock source.

PCI-E Port Max Payload Size

Select Auto for the system BIOS to automatically set the maximum payload value for a PCI-E device to enhance system performance. The options are 128B, 256B, and **Auto**.

► CPU2 PcieBr3D02F0 - Port 3C

Link Speed

Use this feature to select the link speed for the PCIe port. The options are **Auto**, Gen 1 (2.5 GT/s), Gen 2 (5 GT/s), and Gen 3 (8 GT/s).

PCI-E Port Link Status

PCI-E Port Link Max

PCI-E Port Link Speed

PCI-E Port Clocking

The options are Distinct and **Common**. If this item is set to Distinct, this component and the component at the opposite end of the Link are operating with separate reference clock sources. If this item is set to Common, this component and the component at the opposite end of the Link are operating with a common clock source.

PCI-E Port Max Payload Size

Select Auto for the system BIOS to automatically set the maximum payload value for a PCI-E device to enhance system performance. The options are 128B, 256B, and **Auto**.

► IOAT (Intel® IO Acceleration) Configuration

Disable TPH

Select Yes to deactivate TLP Processing Hint support. The options are **No** and Yes.

Prioritize TPH

Use this feature to enable the prioritize TPH support. The options are Enable and **Disable**.

Relaxed Ordering

Select Enable to enable Relaxed Ordering support which will allow certain transactions to violate the strict-ordering rules of PCI bus for a transaction to be completed prior to other transactions that have already been enqueued. The options are **Disable** and Enable.

► Intel® VT for Directed I/O (VT-d)

Intel® VT for Directed I/O (VT-d)

Select Enable to use Intel® Virtualization Technology support for Direct I/O VT-d support by reporting the I/O device assignments to the VMM (Virtual Machine Monitor) through the DMAR ACPI Tables. This feature offers fully-protected I/O resource sharing across Intel® platforms, providing greater reliability, security and availability in networking and data-sharing. The options are **Enable** and Disable.

**If the item above is set to Enable, the following items will be available:*

Interrupt Remapping

Select Enable for Interrupt Remapping support to enhance system performance. The options are **Enable** and Disable.

PassThrough DMA

Select Enable to use the Non-Isoch VT_D engine pass through DMA support. The options are **Enable** and Disable.

ATS

Select Enable to use the Non-Isoch VT_D engine ATS support. The options are **Enable** and Disable.

Posted Interrupt

Use this feature to enable VT_D posted interrupt. The options are **Enable** and Disable.

Coherency Support (Non-Iscoch)

Select Enable for the Non-Iscoch VT-d engine to pass through DMA (Direct Memory Access) to enhance system performance. The options are **Enable** and Disable.

► Intel® VMD technology

The Intel® Volume Management Device (VMD) is a host bridge to a secondary PCIe domain to provide more bus resources.

► Intel® VMD for Volume Management Device on CPU1

VMD Config for PStack0

Intel® VMD for Volume Management Device

Select Enable to use the Intel® Volume Management Device Technology for this stack. The options are **Disable** and Enable.

**If the item above "Intel® VMD for Volume Management Device" is set to Enable, the following items will be displayed:*

P1_NVMe0 VMD (Available when the device is detected by the system)

Select Enable to use the Intel® Volume Management Device Technology for this device. The options are **Disable** and Enable.

P1_NVMe1 VMD (Available when the device is detected by the system)

Select Enable to use the Intel® Volume Management Device Technology for this device. The options are **Disable** and Enable.

P1_NVMe2 VMD (Available when the device is detected by the system)

Select Enable to use the Intel® Volume Management Device Technology for this device. The options are **Disable** and Enable.

P1_NVMe3 VMD (Available when the device is detected by the system)

Select Enable to use the Intel® Volume Management Device Technology for this device. The options are **Disable** and Enable.

Hot Plug Capable (Available when the device is detected by the system)

Use this feature to enable the hot plug support for PCIe root ports 1A~1D. The options are **Disable** and **Enable**.

► Intel® VMD for Volume Management Device on CPU2**VMD Config for PStack0****Intel® VMD for Volume Management Device**

Select **Enable** to use the Intel® Volume Management Device Technology for this stack. The options are **Disable** and **Enable**.

If the item above "Intel® VMD for Volume Management Device" is set to **Enable, the following items will be displayed:*

CPU2 SLOT1 PCI-E 3.0 x8 VMD (Available when the device is detected by the system)

Select **Enable** to use the Intel® Volume Management Device Technology for this device. The options are **Disable** and **Enable**.

Hot Plug Capable (Available when the device is detected by the system)

Use this feature to enable the hot plug support for PCIe root ports 1A~1D. The options are **Disable** and **Enable**.

VMD Config for PStack1**Intel® VMD for Volume Management Device**

Select **Enable** to use the Intel® Volume Management Device Technology for this stack. The options are **Disable** and **Enable**.

If the item above "Intel® VMD for Volume Management Device" is set to **Enable, the following items will be displayed:*

CPU2 SLOT3 PCI-E 3.0 x16 VMD (Available when the device is detected by the system)

Select **Enable** to use the Intel® Volume Management Device Technology for this device. The options are **Disable** and **Enable**.

Hot Plug Capable (Available when the device is detected by the system)

Use this feature to enable the hot plug support for PCIe root ports 2A~2D. The options are **Disable** and **Enable**.

VMD Config for PStack2

Intel® VMD for Volume Management Device

Select Enable to use the Intel® Volume Management Device Technology for this stack. The options are **Disable** and Enable.

**If the item above "Intel® VMD for Volume Management Device" is set to Enable, the following items will be displayed:*

CPU2 SLOT2 PCI-E 3.0 x16 VMD (Available when the device is detected by the system)

Select Enable to use the Intel® Volume Management Device Technology for this device. The options are **Disable** and Enable.

Hot Plug Capable (Available when the device is detected by the system)

Use this feature to enable the hot plug support for PCIe root ports 3A~3D. The options are **Disable** and Enable.

IIO-PCI-E Express Global Options

PCI-E Completion Timeout Disable

Use this feature for PCI-E Completion Timeout support for electric tuning. The options are Yes, **No**, and Per-Port.

► South Bridge

The following South Bridge information will be displayed:

- USB Module Version
- USB Devices

Legacy USB Support

Select Enabled to support onboard legacy USB devices. Select Auto to disable legacy support if there are no legacy USB devices present. Select Disable to have all USB devices available for EFI applications only. The options are **Enabled**, Disabled, and Auto.

XHCI Hand-off

This is a work-around solution for operating systems that do not support XHCI (Extensible Host Controller Interface) hand-off. The XHCI ownership change should be claimed by the XHCI driver. The options are Enabled and **Disabled**.

Port 60/64 Emulation

Select Enabled for I/O port 60h/64h emulation support, which will provide complete legacy USB keyboard support for the operating systems that do not support legacy USB devices. The options are Disabled and **Enabled**.

PCIe PLL SSC

Use this feature to enable PCI-E Phase-locked Loop (PLL) Spread Spectrum Clocking (SSC). The options are **Disable** and Enable.

► Server ME Configuration

This feature displays the following system ME configuration settings.

- Operational Firmware Version
- Backup Firmware Version
- Recovery Firmware Version
- ME Firmware Status #1
- ME Firmware Status #2
 - Current State
 - Error Code

► PCH SATA Configuration**SATA Controller**

This item enables or disables the onboard SATA controller supported by the Intel® PCH chip. The options are Disable and **Enable**.

Configure SATA as

Select AHCI to configure a SATA drive specified by the user as an AHCI drive. Select RAID to configure a SATA drive specified by the user as a RAID drive. The options are **AHCI** and RAID.

SATA HDD Unlock

Select Enable to unlock the HDD password. The options are Disable and **Enable**.

Aggressive Link Power Management

When this item is set to Enable, the SATA AHCI controller manages the power usage of the SATA link. The controller will put the link to a low power state when the I/O is inactive for an extended period of time, and the power state will return to normal when the I/O becomes active. The options are **Disable** and Enable.

**If the item above "Configure SATA as" is set to AHCI, the following items will be displayed:*

SATA Port 0~ Port 3

This item displays the information detected on the installed SATA drive on the particular SATA port.

- Model number of drive and capacity
- Software Preserve Support

Hot Plug (SATA Port 0~ Port 3)

Select Enabled to enable a SATA port specified by the user. The options are Disable and **Enable**.

Spin Up Device (SATA Port 0~ Port 3)

On an edge detect from 0 to 1, set this item to allow the PCH to initialize the device. The options are **Disable** and Enable.

SATA Device Type (SATA Port 0~ Port 3)

Use this item to specify if the SATA port specified by the user should be connected to a Solid State drive or a Hard Disk Drive. The options are **Hard Disk Drive** and Solid State Drive.

**If the item above "Configure SATA as" is set to RAID, the following items will be displayed:*

SATA HDD Unlock

Select Enable to unlock the HDD password. The options are Disable and **Enable**.

SATA RSTe Boot Info

Select Enable to provide the full int13h support for SATA controller attached devices. The options are Disable and **Enable**.

Aggressive Link Power Management

When this item is set to Enable, the SATA Raid controller manages the power usage of the SATA link. The controller will put the link to a low power state when the I/O is inactive for an extended period of time, and the power state will return to normal when the I/O becomes active. The options are **Disable** and Enable.

SATA RAID Option ROM/UEFI Driver

Select EFI to load the EFI driver for system boot. Select Legacy to load a legacy driver for system boot. The options are Disable, EFI, and **Legacy**.

SATA Port 0~ Port 3

This item displays the information detected on the installed SATA drive on the particular SATA port.

- Model number of drive and capacity
- Software Preserve Support

Hot Plug (SATA Port 0~ Port 3)

Select Enabled to enable a SATA port specified by the user. The options are Disable and **Enable**.

Spin Up Device (SATA Port 0~ Port 3)

On an edge detect from 0 to 1, set this item to allow the PCH to initialize the device. The options are **Disable** and Enable.

SATA Device Type (SATA Port 0~ Port 3)

Use this item to specify if the SATA port specified by the user should be connected to a Solid State drive or a Hard Disk Drive. The options are **Hard Disk Drive** and Solid State Drive.

► PCIe/PCI/PnP Configuration

The following information will be displayed:

- PCI Bus Driver Version

PCI Devices Common Settings:

Above 4G Decoding (Available if the system supports 64-bit PCI decoding)

Select Enabled to decode a PCI device that supports 64-bit in the space above 4G Address. The options are Disabled and **Enabled**.

SR-IOV Support

Use this feature to enable or disable Single Root IO Virtualization support. The options are **Disabled** and Enabled.

MMIO High Base

Use this item to select the base memory size according to memory-address mapping for the IO hub. The base memory size must be between 4032G to 4078G. The options are **56T**, 40T, 24T, 16T, 4T, and 1T.

MMIO High Granularity Size

Use this item to select the high memory size according to memory-address mapping for the IO hub. The options are 1G, 4G, 16G, 64G, **256G**, and 1024G.

Maximum Read Request

Select Auto to allow the system BIOS to automatically set the maximum read request size for a PCI-E device to enhance system performance. The options are **Auto**, 128 Bytes, 256 Bytes, 512 Bytes, 1024 Bytes, 2048 Bytes, and 4096 Bytes.

MMCFG Base

Use this feature to select the default value for the PCI MMIO (Memory-Mapped IO) base address. The options are 1G, 1.5G, 1.75G, **2G**, 2.25G, and 3G.

NVMe Firmware Source

Use this item to select the NVMe firmware to support booting. The options are **Vendor Defined Firmware** and AMI Native Support. The default option, **Vendor Defined Firmware**, is pre-installed on the drive and may resolve errata or enable innovative functions for the drive. The other option, AMI Native Support, is offered by the BIOS with a generic method.

VGA Priority

Use this item to select the graphics device to be used as the primary video display for system boot. The options are **Onboard** and Offboard.

CPU2 SLOT1 PCI-E 3.0 x8 OPROM, CPU2 SLOT2 PCI-E 3.0 x16 OPROM, CPU2 SLOT3 PCI-E 3.0 x16 OPROM, CPU1 JMEZZ1 PCI-E 3.0 x8 OPROM

Select Disabled to deactivate the selected slot, Legacy to activate the slot in legacy mode, and EFI to activate the slot in EFI mode. The options are Disabled, **Legacy**, and EFI.

Bus Master Enable

This item allows PCI bus driver enable/disable the bus master bit. The options are Enabled and **Disabled**.

Onboard LAN1 Option ROM

Use this item to select the type of device to be installed in LAN port1 used for system boot. The options are Disabled, **Legacy**, and EFI.

Onboard LAN2 Option ROM

Use this item to select the type of device to be installed in LAN port2 used for system boot. The options are **Disabled**, Legacy, and EFI.

Onboard NVMe1 Option ROM, Onboard NVMe2 Option ROM, Onboard NVMe3 Option ROM, Onboard NVMe4 Option ROM

Select Disabled to deactivate the selected slot, Legacy to activate the slot in legacy mode, and EFI to activate the slot in EFI mode. The options are Disabled, Legacy, and **EFI**.

Onboard Video Option ROM

Select Legacy to boot the system using a legacy video device installed on the motherboard. The options are Disabled, **Legacy**, and EFI.

► Network Stack Configuration

Network Stack

Select Enabled to enable UEFI (Unified Extensible Firmware Interface) for network stack support. The options are Disabled and **Enabled**.

**If the item above "Network Stack" is set to Enabled, the following items will be displayed:*

Ipv4 PXE Support

Select Enabled to enable Ipv4 PXE boot support. The options are Disabled and **Enabled**.

Ipv4 HTTP Support

Select Enabled to enable Ipv4 HTTP boot support. The options are **Disabled** and Enabled.

Ipv6 PXE Support

Select Enabled to enable Ipv6 PXE boot support. The options are Disabled and **Enabled**.

Ipv6 HTTP Support

Select Enabled to enable Ipv6 HTTP boot support. The options are **Disabled** and Enabled.

PXE boot wait time

Use this option to specify the wait time to press the ESC key to abort the PXE boot. Press "+" or "-" on your keyboard to change the value. The default setting is **0**.

Media detect count

Use this option to specify the number of times media will be checked. Press "+" or "-" on your keyboard to change the value. The default setting is **1**.

► Super IO Configuration

Super IO Configuration

The following Super IO information will be displayed:

- Super IO Chip AST2500

► Serial Port 1 Configuration

Serial Port 1 Configuration

This submenu allows the user the configure settings of Serial Port 1.

Serial Port 1

Select Enabled to enable the selected onboard serial port. The options are Disabled and **Enabled**.

Device Settings

This item displays the status of a serial port specified by the user.

Change Settings

This feature specifies the base I/O port address and the Interrupt Request address of a serial port specified by the user. Select Auto to allow the BIOS to automatically assign the base I/O and IRQ address. The options are **Auto**, (IO=3F8h; IRQ=4;), (IO=3F8h; IRQ=3, 4, 5, 6, 7, 9, 10, 11, 12;), (IO=2F8h; IRQ=3, 4, 5, 6, 7, 9, 10, 11, 12;), (IO=3E8h; IRQ=3, 4, 5, 6, 7, 9, 10, 11, 12;), and (IO=2E8h; IRQ=3, 4, 5, 6, 7, 9, 10, 11, 12;).

► Serial Port Console Redirection

COM1

Console Redirection

Select Enabled to enable console redirection support for a serial port specified by the user. The options are **Disabled** and Enabled.

**If the item above is set to Enabled, the following items will become available for user's configuration:*

► Console Redirection Settings

This feature allows the user to specify how the host computer will exchange data with the client computer, which is the remote computer used by the user.

COM1

Console Redirection Settings

Terminal Type

This feature allows the user to select the target terminal emulation type for Console Redirection. Select VT100 to use the ASCII Character set. Select VT100+ to add color and function key support. Select ANSI to use the Extended ASCII Character Set. Select VT-UTF8 to use UTF8 encoding to map Unicode characters into one or more bytes. The options are VT100, **VT100+**, VT-UTF8, and ANSI.

Bits Per second

Use this feature to set the transmission speed for a serial port used in Console Redirection. Make sure that the same speed is used in the host computer and the client computer. A lower transmission speed may be required for long and busy lines. The options are 9600, 19200, 38400, 57600, and **115200** (bits per second).

Data Bits

Use this feature to set the data transmission size for Console Redirection. The options are 7 and **8**.

Parity

A parity bit can be sent along with regular data bits to detect data transmission errors. Select Even if the parity bit is set to 0, and the number of 1's in data bits is even. Select Odd if the parity bit is set to 0, and the number of 1's in data bits is odd. Select None if you do not want to send a parity bit with your data bits in transmission. Select Mark to add a mark as a parity bit to be sent along with the data bits. Select Space to add a Space as a parity bit to be sent with your data bits. The options are **None**, Even, Odd, Mark, and Space.

Stop Bits

A stop bit indicates the end of a serial data packet. Select 1 Stop Bit for standard serial data communication. Select 2 Stop Bits if slower devices are used. The options are **1** and **2**.

Flow Control

Use this feature to set the flow control for Console Redirection to prevent data loss caused by buffer overflow. Send a "Stop" signal to stop sending data when the receiving buffer is full. Send a "Start" signal to start sending data when the receiving buffer is empty. The options are **None** and Hardware RTS/CTS.

VT-UTF8 Combo Key Support

Select Enabled to enable VT-UTF8 Combination Key support for ANSI/VT100 terminals. The options are Disabled and **Enabled**.

Recorder Mode

Select Enabled to capture the data displayed on a terminal and send it as text messages to a remote server. The options are **Disabled** and Enabled.

Resolution 100x31

Select Enabled for extended-terminal resolution support. The options are Disabled and **Enabled**.

Legacy OS Redirection Resolution

Use this feature to select the number of rows and columns used in Console Redirection for legacy OS support. The options are **80x24** and 80x25.

Putty KeyPad

This feature selects the settings for the function keys and the key pad used for Putty, which is a terminal emulator designed for the Windows OS. The options are **VT100**, LINUX, XTERMR6, SC0, ESCN, and VT400.

Redirection After BIOS POST

Use this feature to enable or disable legacy console redirection after BIOS POST. When this feature is set to BootLoader, legacy console redirection is disabled before booting the OS. When this feature is set to Always Enable, legacy console redirection remains enabled when booting the OS. The options are **Always Enable** and BootLoader.

SOL

Console Redirection

Select Enabled to enable console redirection support for a serial port specified by the user. The options are Disabled and **Enabled**.

****If the item above is set to Enabled, the following items will become available for user's configuration:***

► Console Redirection Settings

This feature allows the user to specify how the host computer will exchange data with the client computer, which is the remote computer used by the user.

SOL

Console Redirection Settings

Terminal Type

This feature allows the user to select the target terminal emulation type for Console Redirection. Select VT100 to use the ASCII Character set. Select VT100+ to add color and function key support. Select ANSI to use the Extended ASCII Character Set. Select VT-UTF8 to use UTF8 encoding to map Unicode characters into one or more bytes. The options are VT100, **VT100+**, VT-UTF8, and ANSI.

Bits Per second

Use this feature to set the transmission speed for a serial port used in Console Redirection. Make sure that the same speed is used in the host computer and the client computer. A lower transmission speed may be required for long and busy lines. The options are 9600, 19200, 38400, 57600, and **115200** (bits per second).

Data Bits

Use this feature to set the data transmission size for Console Redirection. The options are 7 and **8**.

Parity

A parity bit can be sent along with regular data bits to detect data transmission errors. Select Even if the parity bit is set to 0, and the number of 1's in data bits is even. Select Odd if the parity bit is set to 0, and the number of 1's in data bits is odd. Select None if you do not want to send a parity bit with your data bits in transmission. Select Mark to add a mark as a parity bit to be sent along with the data bits. Select Space to add a Space as a parity bit to be sent with your data bits. The options are **None**, Even, Odd, Mark, and Space.

Stop Bits

A stop bit indicates the end of a serial data packet. Select 1 Stop Bit for standard serial data communication. Select 2 Stop Bits if slower devices are used. The options are **1** and 2.

Flow Control

Use this feature to set the flow control for Console Redirection to prevent data loss caused by buffer overflow. Send a "Stop" signal to stop sending data when the receiving buffer is full. Send a "Start" signal to start sending data when the receiving buffer is empty. The options are **None** and Hardware RTS/CTS.

VT-UTF8 Combo Key Support

Select Enabled to enable VT-UTF8 Combination Key support for ANSI/VT100 terminals. The options are Disabled and **Enabled**.

Recorder Mode

Select Enabled to capture the data displayed on a terminal and send it as text messages to a remote server. The options are **Disabled** and Enabled.

Resolution 100x31

Select Enabled for extended-terminal resolution support. The options are Disabled and **Enabled**.

Legacy OS Redirection Resolution

Use this feature to select the number of rows and columns used in Console Redirection for legacy OS support. The options are **80x24** and 80x25.

Putty KeyPad

This feature selects the settings for the function keys and the key pad used for Putty, which is a terminal emulator designed for the Windows OS. The options are **VT100**, LINUX, XTERMR6, SC0, ESCN, and VT400.

Redirection After BIOS POST

Use this feature to enable or disable legacy console redirection after BIOS POST. When this feature is set to BootLoader, legacy console redirection is disabled before booting the OS. When this feature is set to Always Enable, legacy console redirection remains enabled when booting the OS. The options are **Always Enable** and BootLoader.

Legacy Console Redirection**Legacy Serial Redirection Port**

Use the feature to select the COM port to display redirection of Legacy OS and Legacy OPRM messages. The options are **COM1** and SOL.

Serial Port for Out-of-Band Management/Windows Emergency Management Services (EMS)

The submenu allows the user to configure Console Redirection settings to support Out-of-Band Serial Port management.

Console Redirection

Select Enabled to use a COM port selected by the user for EMS Console Redirection. The options are **Disabled** and Enabled.

**If the item above is set to Enabled, the following items will become available for user's configuration:*

► Console Redirection Settings

This feature allows the user to specify how the host computer will exchange data with the client computer, which is the remote computer used by the user.

Out-of-Band Management Port

The feature selects a serial port in a client server to be used by the Windows Emergency Management Services (EMS) to communicate with a remote host server. The options are **COM1** and SOL.

Terminal Type

Use this feature to select the target terminal emulation type for Console Redirection. Select VT100 to use the ASCII character set. Select VT100+ to add color and function key support. Select ANSI to use the extended ASCII character set. Select VT-UTF8 to use UTF8 encoding to map Unicode characters into one or more bytes. The options are VT100, VT100+, **VT-UTF8**, and ANSI.

Bits Per second

This item sets the transmission speed for a serial port used in Console Redirection. Make sure that the same speed is used in both host computer and the client computer. A lower transmission speed may be required for long and busy lines. The options are 9600, 19200, 57600, and **115200** (bits per second).

Flow Control

Use this item to set the flow control for Console Redirection to prevent data loss caused by buffer overflow. Send a "Stop" signal to stop data-sending when the receiving buffer is full. Send a "Start" signal to start data-sending when the receiving buffer is empty. The options are **None**, Hardware RTS/CTS, and Software Xon/Xoff.

The settings below are displayed:

Data Bits, Parity, Stop Bits

►ACPI Settings

NUMA (Available when the OS supports this feature)

Select Enabled to enable Non-Uniform Memory Access support to enhance system performance. The options are Disabled and **Enabled**.

WHEA Support

Select Enabled to support the Windows Hardware Error Architecture (WHEA) platform and provide a common infrastructure for the system to handle hardware errors within the Windows OS environment to reduce system crashes and to enhance system recovery and health monitoring. The options are Disabled and **Enabled**.

High Precision Event Timer

Select Enabled to activate the High Precision Event Timer (HPET) that produces periodic interrupts at a much higher frequency than a Real-time Clock (RTC) does in synchronizing multimedia streams, providing smooth playback and reducing the dependency on other timestamp calculation devices, such as an x86 RDTSC Instruction embedded in the CPU. The High Performance Event Timer is used to replace the 8254 Programmable Interval Timer. The options are Disabled and **Enabled**.

►Trusted Computing (Available when a TPM device is installed and detected by the BIOS)

Security Device Support

If a Trusted Platform Module (TPM) device is connected to the TPM header (JTPM1) on the motherboard and this feature is set to Enable, onboard security devices will be available for the TPM support to enhance data integrity and network security. Please reboot the system for a change on this setting to take effect. The options are Disable and **Enable**.

****If the item above is set to Enable, the following items will become available for user's configuration:***

The following Platform Configuration Register information will be displayed:

- **Active PCR banks**
- **Available PCR banks**

SHA256 PCR Bank

Use this item to disable or enable the SHA256 Platform Configuration Register (PCR) bank for the installed TPM device. The options are Disabled and **Enabled**.

Pending operation

Use this item to schedule a TPM-related operation to be performed by a security device for system data integrity. Your system will reboot to carry out a pending TPM operation. The options are **None** and TPM Clear.

Platform Hierarchy

Use this item to disable or enable platform hierarchy for platform protection. The options are Disabled and **Enabled**.

Storage Hierarchy

Use this item to disable or enable storage hierarchy for cryptographic protection. The options are Disabled and **Enabled**.

Endorsement Hierarchy

Use this item to disable or enable endorsement hierarchy for privacy control. The options are Disabled and **Enabled**.

PH Randomization

Use this feature to disable or enable Platform Hierarchy Randomization. The options are **Disabled** and Enabled.

SMC BIOS -Based TPM Provision Support

Use this feature to enable TPM Provision Support. Enabling this feature will lock your TPM. Once locked, the NV indexes will not be able to be deleted. The options are **Disabled** and Enabled.

TXT Support

Intel® TXT (Trusted Execution Technology) helps protect against software-based attacks and ensures protection, confidentiality, and integrity of data stored or created on the system. Use this feature to enable or disable TXT Support. The options are **Disabled** and Enabled.

► iSCSI Configuration (refer to Appendix G for more information)

iSCSI Initiator Name

This feature allows the user to enter the unique name of the iSCSI Initiator in IQN format. Once the name of the iSCSI Initiator is entered into the system, configure the proper settings for the following items.

► Add an Attempt

► Delete Attempts

► Change Attempt order

► Intel® Virtual RAID on CPU (refer to Appendix E for more information)

This submenu displays the information of the Intel® VMD controllers as detected by the BIOS.

6.4 Event Logs

Use this feature to configure Event Log settings.

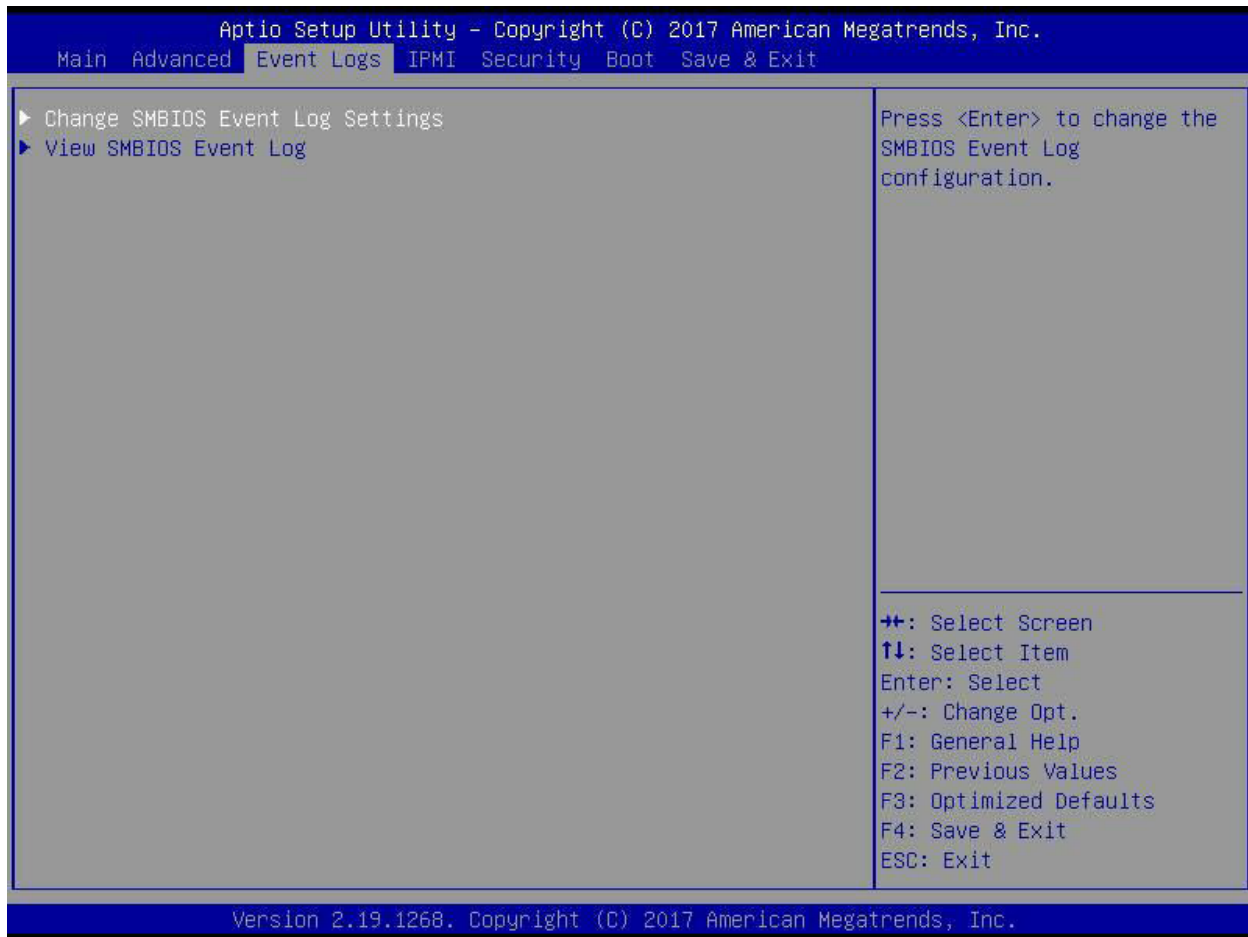

▶ Change SMBIOS Event Log Settings

Enabling/Disabling Options

SMBIOS Event Log

Change this item to enable or disable all features of the SMBIOS (System Management BIOS) Event Logging during system boot. The options are Disabled and **Enabled**.

Erasing Settings

Erase Event Log

If No is selected, data stored in the event log will not be erased. Select Yes, Next Reset, data in the event log will be erased upon next system reboot. Select Yes, Every Reset, data in the event log will be erased upon every system reboot. The options are **No**, (Yes, Next reset), and (Yes, Every reset).

When Log is Full

Select Erase Immediately for all messages to be automatically erased from the event log when the event log memory is full. The options are **Do Nothing** and Erase Immediately.

SMBIOS Event Log Standard Settings

Log System Boot Event

This option toggles the System Boot Event logging to enabled or disabled. The options are Enabled and **Disabled**.

MECI

The Multiple Event Count Increment (MECI) counter counts the number of occurrences that a duplicate event must happen before the MECI counter is incremented. This is a numeric value. The default value is **1**.

METW

The Multiple Event Time Window (METW) defines number of minutes must pass between duplicate log events before MECI is incremented. This is in minutes, from 0 to 99. The default value is **60**.

Note: After making changes on a setting, be sure to reboot the system for the changes to take effect.

►View SMBIOS Event Log

This section displays the contents of the SMBIOS Event Log.

6.5 IPMI

Use this feature to configure Intelligent Platform Management Interface (IPMI) settings.



When you select this submenu and press the <Enter> key, the following information will display:

- IPMI Firmware Revision: This feature indicates the IPMI firmware revision used in your system.
- Status of BMC: This feature indicates the status of the BMC (Baseboard Management Controller) installed in your system.

▶ System Event Log

Enabling/Disabling Options

SEL Components

Select Enabled for all system event logging at bootup. The options are **Enabled** and Disabled.

Erasing Settings

Erase SEL

Select Yes, On next reset to erase all system event logs upon next system reboot. Select Yes, On every reset to erase all system event logs upon each system reboot. Select No to keep all system event logs after each system reboot. The options are **No**, Yes, On next reset, and Yes, On every reset.

When SEL is Full

This feature allows the user to determine what the BIOS should do when the system event log is full. Select Erase Immediately to erase all events in the log when the system event log is full. The options are **Do Nothing** and Erase Immediately.

Custom EFI Logging Options

Log EFI Status Codes

Select EFI (Extensible Firmware Interface) Status Codes to log EFI status codes. Select Error Codes to log EFI error codes. Select Progress Code to log the EFI progress code. Select both to log both EFI error codes and progress codes. The options are Disabled, Both, **Error code** and Progress code.

Note: After making changes on a setting, be sure to reboot the system for the changes to take effect.

► BMC Network Configuration

The following items will be displayed:

- IPMI LAN Selection: This feature displays the IPMI LAN setting. The default setting is **Failover**.
- IPMI Network Link Status: This item displays the IPMI Network Link status. The default setting is **Dedicated LAN**.
- Current Configuration Address Source: This feature displays the source of the current IPMI LAN address. The default setting is **DHCP (Dynamic Host Configuration Protocol)**.
- Station IP Address: This feature displays the Station IP address for this computer. This should be in decimal and in dotted quad form (i.e., 192.168.10.253).
- Subnet Mask: This feature displays the sub-network that this computer belongs to. The value of each three-digit number separated by dots should not exceed 255.
- Station MAC Address: This feature displays the Station MAC address for this computer. Mac addresses are 6 two-digit hexadecimal numbers.

- **Gateway IP Address:** This feature displays the Gateway IP address for this computer. This should be in decimal and in dotted quad form (i.e., 192.168.10.253).
- **VLAN:** Select Enabled to enable IPMI VLAN support. The options are **Enabled** and Disabled.

Update IPMI LAN Configuration

Select Yes for the BIOS to implement all IP/MAC address changes at the next system boot. The default setting is **Yes**.

IPMI LAN Selection

Use this feature to configure the IPMI LAN mode setting. The options are Dedicated, Shared, and **Failover**.

VLAN Support

Select Enabled for IPMI VLAN support. The options are **Disabled** and Enabled.

Configuration Address Source

Use this feature to select the IP address source for this computer. If Static is selected, you will need to know the IP address of this computer and enter it to the system manually in the field. If DHCP is selected, AMI BIOS will search for a DHCP (Dynamic Host Configuration Protocol) server attached to the network and request the next available IP address for this computer. The options are **DHCP** and Static.

6.6 Security Settings

This menu allows the user to configure the following security settings for the system.

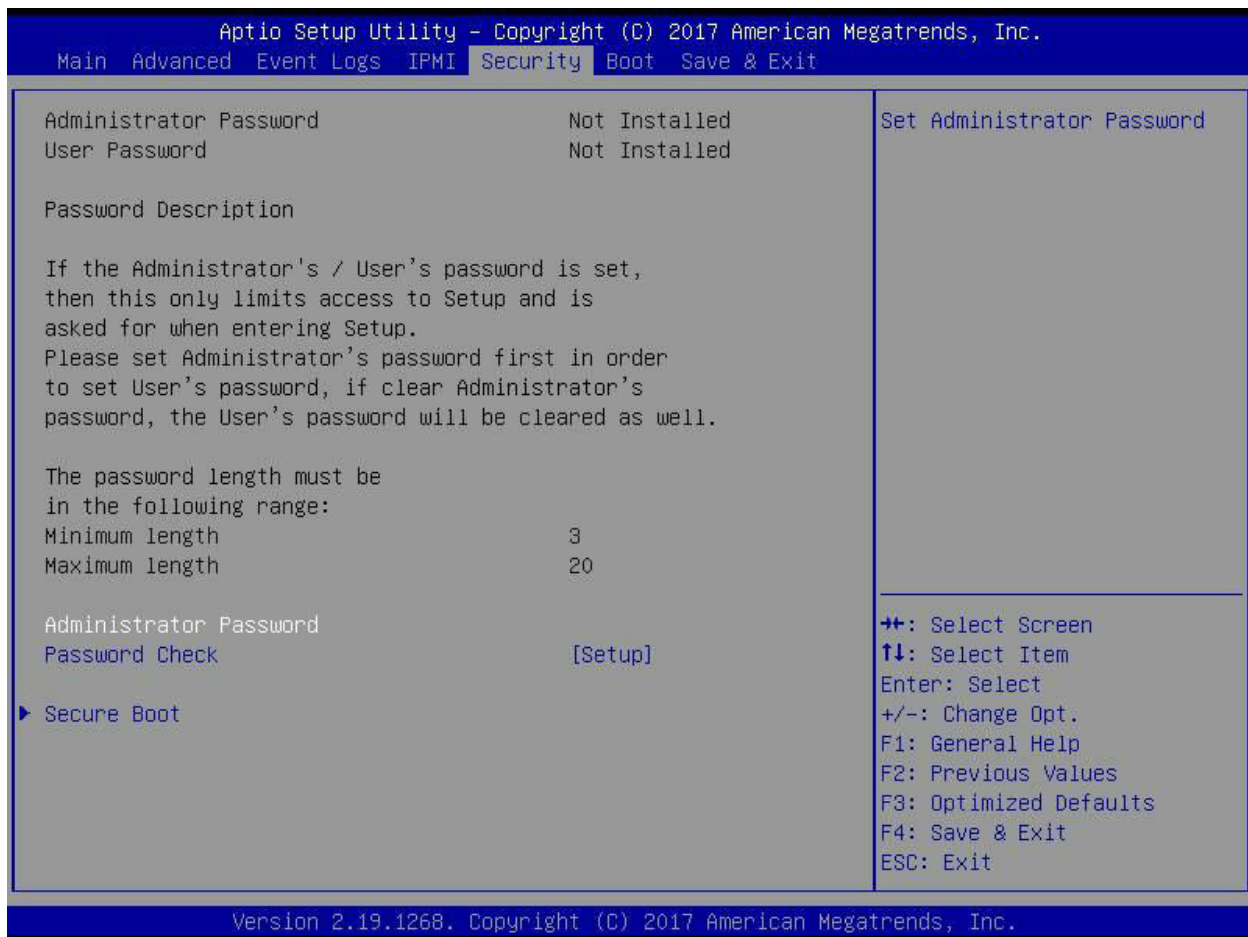

Administrator Password

Press Enter to set the user password which is required to enter the BIOS setup utility. The length of the password should be from 3 characters to 20 characters long.

Password Check

Select Setup for the system to check for a password at Setup. Select Always for the system to check for a password at bootup or upon entering the BIOS Setup utility. The options are **Setup** and **Always**.

► Secure Boot (refer to Appendix F for more information)

This section displays the contents of the following secure boot features:

- System Mode
- Secure Boot
- Vendor Keys

Secure Boot

This feature is available when the platform key (PK) is pre-registered where the platform operates in the user mode and compatibility support module (CSM) support is disabled in the BIOS Setup utility. Select Enabled for secure boot flow control. The options are **Disabled** and Enabled.

Secure Boot Mode

This feature allows selection of the secure boot mode. The options are Standard and **Custom**. Select Standard to load manufacturer's default secure variables. Selecting Custom allows users to change the image execution policy and to manage secure boot keys.

CSM Support

Select Enabled to support the legacy Compatibility Support Module (CSM), which provides compatibility support for traditional legacy BIOS for system boot. The options are Disabled and **Enabled**.

► Key Management

This submenu allows the user to configure the following Key Management settings.

Provision Factory Defaults

This feature allows provisioning the default secure boot keys set by the manufacturer when system is in the setup mode. The options are **Disabled** and Enabled.

► Enroll all Factory Default Keys

Select Yes to install all default secure keys set by the manufacturer. The options are **Yes** and No.

► Enroll Efi Image

This feature allows the image to run in the secure boot mode and the enroll of SHA256 hash of the binary into the Authorized Signature Database (DB).

► Save all Secure Boot variables

This feature allows the user to decide if all secure boot variables should be saved.

Secure Boot variable: Size/ Key#/ Key Source

▶ Platform Key (PK)

The Platform Key (PK), which is pre-installed in firmware during manufacturing, provides full control of the secure boot key hierarchy. The options are **Save to File**, Set New, and Erase.

▶ Key Exchange Keys (KEK)

The Key Exchange Key (KEK), which is held by the operating system vendor, can be updated by the holder of the PK and be used by secure boot to protect access to signatures databases. The options are **Save to File**, Set New, Append, and Erase.

▶ Authorized Signatures

Authorized Signature Database (DB) contains authorized signing certificates and digital signatures. The options are **Save to File**, Set New, Append, and Erase.

▶ Forbidden Signatures

Forbidden Signature Database (DBX), which is the inverse of DB, contains forbidden certificates and digital signatures. The options are **Save to File**, Set New, Append, and Erase

▶ Authorized TimeStamps

Authorized Timestamp Database (DBT) is used to issue and check signed time stamp certificates. The options are Save to File, Set New, Append, and Erase

▶ OsRecovery Signatures

OsRecovery Signatures Database (DBR) contains secure boot authorized recovery variables. The options are **Save to File**, Set New, Append, and Erase

6.7 Boot Settings

Use this feature to configure Boot Settings:

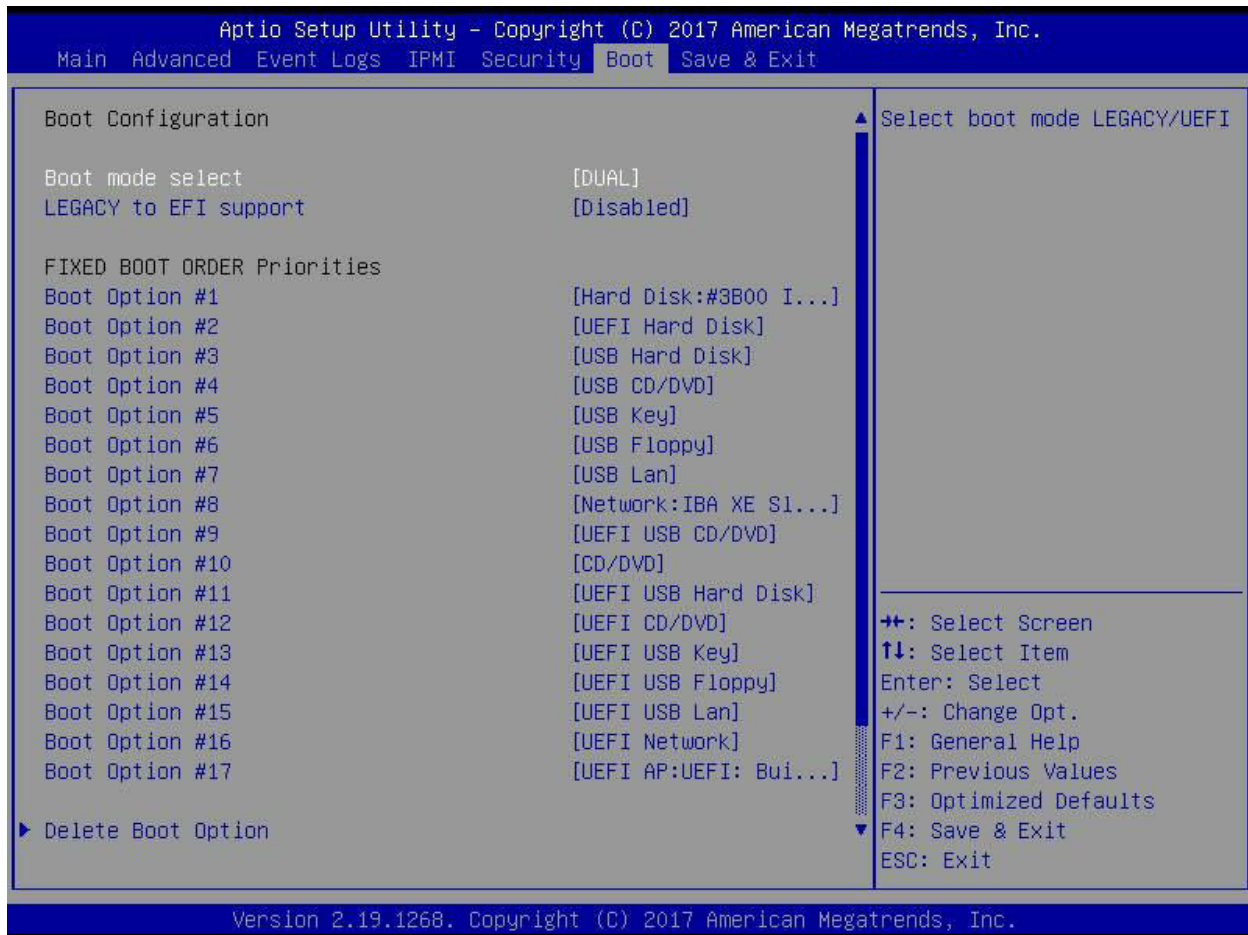

Use this feature to configure Boot Settings:

Boot mode select

Use this item to select the type of device that the system is going to boot from. The options are LEGACY, UEFI, and **DUAL**. The default setting is **DUAL**.

LEGACY to EFI support

Use this item to enable the EFI boot support. The options are **Disabled** and Enabled.

FIXED BOOT ORDER Priorities

This option prioritizes the order of bootable devices that the system to boot from. Press <Enter> on each entry from top to bottom to select devices.

****If the item above, "Boot mode select", is set to Legacy/UEFI/Dual, the following items will be displayed:***

- Legacy/UEFI/Dual Boot Order #1
- Legacy/UEFI/Dual Boot Order #2

- Legacy/UEFI/Dual Boot Order #3
- Legacy/UEFI/Dual Boot Order #4
- Legacy/UEFI/Dual Boot Order #5
- Legacy/UEFI/Dual Boot Order #6
- Legacy/UEFI/Dual Boot Order #7
- Legacy/UEFI/Dual Boot Order #8
- UEFI/Dual Boot Order #9
- Dual Boot Order #10
- Dual Boot Order #11
- Dual Boot Order #12
- Dual Boot Order #13
- Dual Boot Order #14
- Dual Boot Order #15
- Dual Boot Order #16
- Dual Boot Order #17

►Delete Boot Option

Use this feature to remove a pre-defined boot device from which the system will boot during startup. The options are **Select one to Delete**, UEFI: Built-in EFI Shell, and CentOS.

►UEFI Application Boot Priorities

This feature allows the user to specify which UEFI devices are boot devices.

Boot Option #1

The options are **UEFI: Built-in EFI Shell** and Disabled.

►Hard Disk Drive BBS Priorities

This feature allows the user to specify the boot device priority from the available hard disk drives.

Boot Option #1

The options are **(the available hard disk drive)** and Disabled.

► Network Drive BBS Priorities

This feature allows the user to specify which available network drives are boot devices.

Boot Option #1

The options are **IBA XE Slot 0100 v2398** and Disabled.

► UEFI Application Boot Priorities

- Boot Option #1

6.8 Save & Exit

Select the Save & Exit tab from the BIOS setup screen to configure the settings below.

```

Aptio Setup Utility - Copyright (C) 2017 American Megatrends, Inc.
Main  Advanced  Event Logs  IPMI  Security  Boot  Save & Exit

Save Options
Discard Changes and Exit
Save Changes and Reset
Save Changes
Discard Changes

Default Options
Restore Optimized Defaults
Save as User Defaults
Restore User Defaults

Boot Override
#3B00 ID0B LUN0 ATA      HGST HMS5C4040
IBA XE Slot 5E00 v2366
UEFI: Built-in EFI Shell

Exit system setup without
saving any changes.

+*: Select Screen
↑↓: Select Item
Enter: Select
+/-: Change Opt.
F1: General Help
F2: Previous Values
F3: Optimized Defaults
F4: Save & Exit
ESC: Exit

Version 2.19.1268. Copyright (C) 2017 American Megatrends, Inc.

```

Save Options

Discard Changes and Exit

Select this option to quit the BIOS Setup without making any permanent changes to the system configuration, and reboot the computer. Select Discard Changes and Exit from the Exit menu and press <Enter>.

Save Changes and Reset

After completing the system configuration changes, select this option to save the changes you have made. This will reset (reboot) the system.

Save Changes

When you have completed the system configuration changes, select this option to save all changes made. This will not reset (reboot) the system.

Discard Changes

Select this option and press <Enter> to discard all the changes and return to the AMI BIOS utility Program.

Listed on this section are other boot options for the system (i.e., Built-in EFI shell). Select an option and press <Enter>. Your system will boot to the selected boot option.

Default Options

Restore Optimized Defaults

To set this feature, select Restore Optimized Defaults from the Save & Exit menu and press <Enter>. These are factory settings designed for maximum system stability, but not for maximum performance.

Save As User Defaults

To set this feature, select Save as User Defaults from the Exit menu and press <Enter>. This enables the user to save any changes to the BIOS setup for future use.

Restore User Defaults

To set this feature, select Restore User Defaults from the Exit menu and press <Enter>. Use this feature to retrieve user-defined settings that were saved previously.

Boot Override

Listed on this section are other boot options for the system (i.e., Built-in EFI shell). Select an option and press <Enter>. Your system will boot to the selected boot option.

Appendix A

BIOS Error Codes

A.1 BIOS Error Beep (POST) Codes

During the POST (Power-On Self-Test) routines, which are performed each time the system is powered on, errors may occur.

Non-fatal errors are those which, in most cases, allow the system to continue the boot-up process. The error messages normally appear on the screen.

Fatal errors are those which will not allow the system to continue the boot-up procedure. If a fatal error occurs, you should consult with your system manufacturer for possible repairs.

These fatal errors are usually communicated through a series of audible beeps. The numbers on the fatal error list (on the following page) correspond to the number of beeps for the corresponding error.

BIOS Beep (POST) Codes		
Beep Code	Error Message	Description
1 beep	Refresh	Circuits have been reset (Ready to power up)
5 short, 1 long	Memory error	No memory detected in system
5 long, 2 short	Display memory read/write error	Video adapter missing or with faulty memory
1 long continuous	System OH	System overheat condition

A.2 Additional BIOS POST Codes

The AMI BIOS supplies additional checkpoint codes, which are documented online at <http://www.supermicro.com/support/manuals/> ("AMI BIOS POST Codes User's Guide").

When BIOS performs the Power On Self Test, it writes checkpoint codes to I/O port 0080h. If the computer cannot complete the boot process, a diagnostic card can be attached to the computer to read I/O port 0080h (Supermicro p/n AOC-LPC80-20).

For information on AMI updates, please refer to <http://www.ami.com/products/>.

Appendix B

Standardized Warning Statements for AC Systems

B.1 About Standardized Warning Statements

The following statements are industry standard warnings, provided to warn the user of situations which have the potential for bodily injury. Should you have questions or experience difficulty, contact Supermicro's Technical Support department for assistance. Only certified technicians should attempt to install or configure components.

Read this appendix in its entirety before installing or configuring components in the Supermicro chassis.

These warnings may also be found on our website at http://www.supermicro.com/about/policies/safety_information.cfm.

Warning Definition



Warning! This warning symbol means danger. You are in a situation that could cause bodily injury. Before you work on any equipment, be aware of the hazards involved with electrical circuitry and be familiar with standard practices for preventing accidents.

警告の定義

この警告サインは危険を意味します。

人身事故につながる可能性がありますので、いずれの機器でも動作させる前に、電気回路に含まれる危険性に注意して、標準的な事故防止策に精通して下さい。

此警告符号代表危險。

您正处于可能受到严重伤害的工作环境中。在您使用设备开始工作之前，必须充分意识到触电的危险，并熟练掌握防止事故发生的标准工作程序。请根据每项警告结尾的声明号码找到此设备的安全性警告说明的翻译文本。

此警告符號代表危險。

您正處於可能身體可能會受損傷的工作環境中。在您使用任何設備之前，請注意觸電的危險，並且要熟悉預防事故發生的標準工作程序。請依照每一注意事項後的號碼找到相關的翻譯說明內容。

Warnung

WICHTIGE SICHERHEITSHINWEISE

Dieses Warnsymbol bedeutet Gefahr. Sie befinden sich in einer Situation, die zu Verletzungen führen kann. Machen Sie sich vor der Arbeit mit Geräten mit den Gefahren elektrischer Schaltungen und den üblichen Verfahren zur Vorbeugung vor Unfällen vertraut. Suchen Sie mit der am Ende jeder Warnung angegebenen Anweisungsnummer nach der jeweiligen Übersetzung in den übersetzten Sicherheitshinweisen, die zusammen mit diesem Gerät ausgeliefert wurden.

BEWAHREN SIE DIESE HINWEISE GUT AUF.

INSTRUCCIONES IMPORTANTES DE SEGURIDAD

Este símbolo de aviso indica peligro. Existe riesgo para su integridad física. Antes de manipular cualquier equipo, considere los riesgos de la corriente eléctrica y familiarícese con los procedimientos estándar de prevención de accidentes. Al final de cada advertencia encontrará el número que le ayudará a encontrar el texto traducido en el apartado de traducciones que acompaña a este dispositivo.

GUARDE ESTAS INSTRUCCIONES.

IMPORTANTES INFORMATIONS DE SÉCURITÉ

Ce symbole d'avertissement indique un danger. Vous vous trouvez dans une situation pouvant entraîner des blessures ou des dommages corporels. Avant de travailler sur un équipement, soyez conscient des dangers liés aux circuits électriques et familiarisez-vous avec les procédures couramment utilisées pour éviter les accidents. Pour prendre connaissance des traductions des avertissements figurant dans les consignes de sécurité traduites qui accompagnent cet appareil, référez-vous au numéro de l'instruction situé à la fin de chaque avertissement.

CONSERVEZ CES INFORMATIONS.

תקנון הזהרות אזהרה

הזהרות הבאות הן אזהרות על פי תקני התעשייה, על מנת להזהיר את המשתמש מפני חבלה פיזית אפשרית. במידה ויש שאלות או היתקלות בבעיה כלשהי, יש ליצור קשר עם מחלקת תמיכה טכנית של סופרמיקרו. טכנאים מוסמכים בלבד רשאים להתקין או להגדיר את הרכיבים. יש לקרוא את הנספח במלואו לפני התקנת או הגדרת הרכיבים במארזי סופרמיקרו.

اَكْ ف حالة وُكِي اَي تتسبب ف اصابة جسدهُ هذا الزهز عُ خطر! تحذُرُ .
قبل اَي تعول على اَي هعدات، كي على علن بالوخاطز ال اُجوة عي الذوائر
الكهزبائِة
وكي على دراةُ بالووارسات النقااِة لو عُ وقع اَي حادث
استخدم رقن الب اِى الو صُص ف هاةُ كل تحذُرُ للعشر تزجوتها

안전을 위한 주의사항

경고!

이 경고 기호는 위험이 있음을 알려 줍니다. 작업자의 신체에 부상을 야기 할 수 있는 상태에 있게 됩니다. 모든 장비에 대한 작업을 수행하기 전에 전기회로와 관련된 위험요소들을 확인하시고 사전에 사고를 방지할 수 있도록 표준 작업절차를 준수해 주시기 바랍니다.

해당 번역문을 찾기 위해 각 경고의 마지막 부분에 제공된 경고문 번호를 참조하십시오

BELANGRIJKE VEILIGHEIDSINSTRUCTIES

Dit waarschuwings symbool betekent gevaar. U verkeert in een situatie die lichamelijk letsel kan veroorzaken. Voordat u aan enige apparatuur gaat werken, dient u zich bewust te zijn van de bij een elektrische installatie betrokken risico's en dient u op de hoogte te zijn van de standaard procedures om ongelukken te voorkomen. Gebruik de nummers aan het eind van elke waarschuwing om deze te herleiden naar de desbetreffende locatie.

BEWAAR DEZE INSTRUCTIES

Installation Instructions



Warning! Read the installation instructions before connecting the system to the power source.

設置手順書

システムを電源に接続する前に、設置手順書をお読み下さい。

警告

将此系统连接电源前,请先阅读安装说明。

警告

將系統與電源連接前，請先閱讀安裝說明。

Warnung

Vor dem Anschließen des Systems an die Stromquelle die Installationsanweisungen lesen.

¡Advertencia!

Lea las instrucciones de instalación antes de conectar el sistema a la red de alimentación.

Attention

Avant de brancher le système sur la source d'alimentation, consulter les directives d'installation.

יש לקרוא את הוראות התקנה לפני חיבור המערכת למקור מתח.

اقرأ إرشادات التركيب قبل توصيل النظام إلى مصدر للطاقة

시스템을 전원에 연결하기 전에 설치 안내를 읽어주십시오.

Waarschuwing

Raadpleeg de installatie-instructies voordat u het systeem op de voedingsbron aansluit.

Circuit Breaker

Warning! This product relies on the building's installation for short-circuit (overcurrent) protection. Ensure that the protective device is rated not greater than: 250 V, 20 A.

サーキット・ブレーカー

この製品は、短絡(過電流)保護装置がある建物での設置を前提としています。

保護装置の定格が250 V、20 Aを超えないことを確認下さい。

警告

此产品的短路(过载电流)保护由建筑物的供电系统提供,确保短路保护设备的额定电流不大于250V,20A。

警告

此產品的短路(過載電流)保護由建築物的供電系統提供,確保短路保護設備的額定電流不大於250V,20A。

Warnung

Dieses Produkt ist darauf angewiesen, dass im Gebäude ein Kurzschluss- bzw. Überstromschutz installiert ist. Stellen Sie sicher, dass der Nennwert der Schutzvorrichtung nicht mehr als: 250 V, 20 A beträgt.

¡Advertencia!

Este equipo utiliza el sistema de protección contra cortocircuitos (o sobrecorrientes) del edificio. Asegúrese de que el dispositivo de protección no sea superior a: 250 V, 20 A.

Attention

Pour ce qui est de la protection contre les courts-circuits (surtension), ce produit dépend de l'installation électrique du local. Vérifiez que le courant nominal du dispositif de protection n'est pas supérieur à :250 V, 20 A.

מוצר זה מסתמך על הגנה המותקנת במבנים למניעת קצר חשמלי. יש לוודא כי המכשיר המגן מפני הקצר החשמלי הוא לא יותר מ-250VDC, 20A

هذا المنتج يعتمد على معدات الحماية مه الدوائر القصيرة التي تم تثبيتها في المبنى
تأكد من أن تقييم الجهاز الوقائي ليس أكثر من : 20A, 250V

경고!

이 제품은 전원의 단락(과전류)방지에 대해서 전적으로 건물의 관련 설비에 의존합니다. 보호장치의 정격이 반드시 250V(볼트), 20A(암페어)를 초과하지 않도록 해야 합니다.

Waarschuwing

Dit product is afhankelijk van de kortsluitbeveiliging (overspanning) van uw elektrische installatie. Controleer of het beveiligde apparaat niet groter gedimensioneerd is dan 250V, 20A.

Power Disconnection Warning



Warning! The system must be disconnected from all sources of power and the power cord removed from the power supply module(s) before accessing the chassis interior to install or remove system components.

電源切斷の警告

システムコンポーネントの取り付けまたは取り外しのために、シャーシ内部にアクセスするには、システムの電源はすべてのソースから切斷され、電源コードは電源モジュールから取り外す必要があります。

警告

在你打开机箱并安装或移除内部器件前,必须将系统完全断电,并移除电源线。

警告

在您打開機殼安裝或移除內部元件前，必須將系統完全斷電，並移除電源線。

Warnung

Das System muss von allen Quellen der Energie und vom Netzanschlusskabel getrennt sein, das von den Spg.Versorgungsteilmodulen entfernt wird, bevor es auf den Chassisinnenraum zurückgreift, um Systemsbestandteile anzubringen oder zu entfernen.

¡Advertencia!

El sistema debe ser disconnected de todas las fuentes de energía y del cable eléctrico quitado de los módulos de fuente de alimentación antes de tener acceso el interior del chasis para instalar o para quitar componentes de sistema.

Attention

Le système doit être débranché de toutes les sources de puissance ainsi que de son cordon d'alimentation secteur avant d'accéder à l'intérieur du chasis pour installer ou enlever des composants de système.

אזהרה מפני ניתוק חשמלי

אזהרה!

יש לנתק את המערכת מכל מקורות החשמל ויש להסיר את כבל החשמלי מהספק לפני גישה לחלק הפנימי של המארז לצורך התקנת או הסרת רכיבים.

يجب فصل انظاؤ من جميع مصادر انطاقت وإزانت سهك انكهرباء من وحدة امداد
انطاقت قيم
انصل إلى امناطق انداخهيت نههيكم نتشيج أو إزانت مكناث الجهاز

경고!

시스템에 부품들을 장착하거나 제거하기 위해서는 새시 내부에 접근하기 전에 반드시 전원 공급장치로부터 연결되어있는 모든 전원과 전기코드를 분리해주어야 합니다.

Waarschuwing

Voordat u toegang neemt tot het binnenwerk van de behuizing voor het installeren of verwijderen van systeem onderdelen, dient u alle spanningsbronnen en alle stroomkabels aangesloten op de voeding(en) van de behuizing te verwijderen

Equipment Installation



Warning! Only trained and qualified personnel should be allowed to install, replace, or service this equipment.

機器の設置

トレーニングを受け認定された人だけがこの装置の設置、交換、またはサービスを許可されてい
ます。

警告

只有经过培训且具有资格的人员才能进行此设备的安装、更换和维修。

警告

只有經過受訓且具資格人員才可安裝、更換與維修此設備。

Warnung

Das Installieren, Ersetzen oder Bedienen dieser Ausrüstung sollte nur geschultem, qualifiziertem Personal gestattet werden.

¡Advertencia!

Solamente el personal calificado debe instalar, reemplazar o utilizar este equipo.

Attention

Il est vivement recommandé de confier l'installation, le remplacement et la maintenance de ces équipements à des personnels qualifiés et expérimentés.

אזהרה!

צוות מוסמך בלבד רשאי להתקין, להחליף את הציוד או לתת שירות עבור הציוד.

والمدربيه لتزكيب واستبدال أو خدمة هذا الجهاز يجب أن يسمح فقط للمظفيه المؤهليه

경고!

훈련을 받고 공인된 기술자만이 이 장비의 설치, 교체 또는 서비스를 수행할 수 있습니다.

Waarschuwing

Deze apparatuur mag alleen worden geïnstalleerd, vervangen of hersteld door geschoold en gekwalificeerd personeel.

Restricted Area

Warning! This unit is intended for installation in restricted access areas. A restricted access area can be accessed only through the use of a special tool, lock and key, or other means of security. (This warning does not apply to workstations).

アクセス制限区域

このユニットは、アクセス制限区域に設置されることを想定しています。

アクセス制限区域は、特別なツール、鍵と錠前、その他のセキュリティの手段を用いてのみ出入りが可能です。

警告

此部件应安装在限制进出的场所，限制进出的场所指只能通过使用特殊工具、锁和钥匙或其它安全手段进出的场所。

警告

此装置僅限安裝於進出管制區域，進出管制區域係指僅能以特殊工具、鎖頭及鑰匙或其他安全方式才能進入的區域。

Warnung

Diese Einheit ist zur Installation in Bereichen mit beschränktem Zutritt vorgesehen. Der Zutritt zu derartigen Bereichen ist nur mit einem Spezialwerkzeug, Schloss und Schlüssel oder einer sonstigen Sicherheitsvorkehrung möglich.

¡Advertencia!

Esta unidad ha sido diseñada para instalación en áreas de acceso restringido. Sólo puede obtenerse acceso a una de estas áreas mediante la utilización de una herramienta especial, cerradura con llave u otro medio de seguridad.

Attention

Cet appareil doit être installé dans des zones d'accès réservés. L'accès à une zone d'accès réservé n'est possible qu'en utilisant un outil spécial, un mécanisme de verrouillage et une clé, ou tout autre moyen de sécurité.

אזור עם גישה מוגבלת

אזהרה!

יש להתקין את היחידה באזורים שיש בהם הגבלת גישה. הגישה ניתנת בעזרת 'כלי אבטחה בלבד' (מפתח, מנעול וכד.).

تخصيص هذه انحدة نترك بُها ف مناطق محظورة تم .
ممكن اننصل إن منطقت محظورة فقط من خلال استخذاو أداة خاصت
أو أ وس هُت أخري نلالأمما ققم ومفتاح

경고!

이 장치는 접근이 제한된 구역에 설치하도록 되어있습니다. 특수도구, 잠금 장치 및 키, 또는 기타 보안 수단을 통해서만 접근 제한 구역에 들어갈 수 있습니다.

Waarschuwing

Dit apparaat is bedoeld voor installatie in gebieden met een beperkte toegang. Toegang tot dergelijke gebieden kunnen alleen verkregen worden door gebruik te maken van speciaal gereedschap, slot en sleutel of andere veiligheidsmaatregelen.

Battery Handling



Warning! There is the danger of explosion if the battery is replaced incorrectly. Replace the battery only with the same or equivalent type recommended by the manufacturer. Dispose of used batteries according to the manufacturer's instructions

電池の取り扱い

電池交換が正しく行われなかった場合、破裂の危険性があります。交換する電池はメーカーが推奨する型、または同等のものを使用下さい。使用済電池は製造元の指示に従って処分して下さい。

警告

電池更換不當會有爆炸危險。請只使用同類電池或制造商推薦的功能相當的電池更換原有電池。請按製造商的說明處理廢舊電池。

警告

電池更換不當會有爆炸危險。請使用製造商建議之相同或功能相當的電池更換原有電池。請按照製造商的說明指示處理廢棄舊電池。

Warnung

Bei Einsetzen einer falschen Batterie besteht Explosionsgefahr. Ersetzen Sie die Batterie nur durch den gleichen oder vom Hersteller empfohlenen Batterietyp. Entsorgen Sie die benutzten Batterien nach den Anweisungen des Herstellers.

Attention

Danger d'explosion si la pile n'est pas remplacée correctement. Ne la remplacer que par une pile de type semblable ou équivalent, recommandée par le fabricant. Jeter les piles usagées conformément aux instructions du fabricant.

¡Advertencia!

Existe peligro de explosión si la batería se reemplaza de manera incorrecta. Reemplazar la batería exclusivamente con el mismo tipo o el equivalente recomendado por el fabricante. Desechar las baterías gastadas según las instrucciones del fabricante.

אזהרה!

קיימת סכנת פיצוץ של הסוללה במידה והוחלפה בדרך לא תקינה. יש להחליף את הסוללה בסוג התואם מחברת יצרן מומלצת. סילוק הסוללות המשומשות יש לבצע לפי הוראות היצרן.

هناك خطر من انفجار في حالة اسبدال البطارية بطريقة غير صحيحة فعلى
اسبدال البطارية
فقط بنفس النوع أو ما يعادلها مما أوصت به الشركة المصنعة
جخلص من البطاريات المسحومة وفقا لعمليات الشركة الصانعة

경고!

배터리가 올바르게 교체되지 않으면 폭발의 위험이 있습니다. 기존 배터리와 동일하거나 제조사에서 권장하는 동등한 종류의 배터리로만 교체해야 합니다. 제조사의 안내에 따라 사용된 배터리를 처리하여 주십시오.

Waarschuwing

Er is ontplofingsgevaar indien de batterij verkeerd vervangen wordt. Vervang de batterij slechts met hetzelfde of een equivalent type die door de fabrikant aanbevolen wordt. Gebruikte batterijen dienen overeenkomstig fabrieksvoorschriften afgevoerd te worden.

Redundant Power Supplies



Warning! This unit might have more than one power supply connection. All connections must be removed to de-energize the unit.

冗長電源装置

このユニットは複数の電源装置が接続されている場合があります。

ユニットの電源を切るためには、すべての接続を取り外さなければなりません。

警告

此部件连接的电源可能不止一个，必须将所有电源断开才能停止给该部件供电。

警告

此装置连接的电源可能不只一个，必须切断所有电源才能停止对该装置的供电。

Warnung

Dieses Gerät kann mehr als eine Stromzufuhr haben. Um sicherzustellen, dass der Einheit kein Strom zugeführt wird, müssen alle Verbindungen entfernt werden.

¡Advertencia!

Puede que esta unidad tenga más de una conexión para fuentes de alimentación. Para cortar por completo el suministro de energía, deben desconectarse todas las conexiones.

Attention

Cette unité peut avoir plus d'une connexion d'alimentation. Pour supprimer toute tension et tout courant électrique de l'unité, toutes les connexions d'alimentation doivent être débranchées.

אם קיים יותר מספק אחד

אזהרה!

ליחידה יש יותר מחיבור אחד של ספק. יש להסיר את כל החיבורים על מנת לרוקן את היחידה.

قد يكون لهذا الجهاز عدة اتصالات بوحدات امداد الطاقة .

يجب إزالة كافة الاتصالات لعسل الوحدة عن الكهرباء

경고!

이 장치에는 한 개 이상의 전원 공급 단자가 연결되어 있을 수 있습니다. 이 장치에 전원을 차단하기 위해서는 모든 연결 단자를 제거해야만 합니다.

Waarschuwing

Deze eenheid kan meer dan één stroomtoevoeraansluiting bevatten. Alle aansluitingen dienen verwijderd te worden om het apparaat stroomloos te maken.

Backplane Voltage



Warning! Hazardous voltage or energy is present on the backplane when the system is operating. Use caution when servicing.

バックプレーンの電圧

システムの稼働中は危険な電圧または電力が、バックプレーン上にかかっています。

修理する際には注意ください。

警告

当システム正在进行時、背板上有很危险的电压或能量、进行维修时务必小心。

警告

當系統正在進行時、背板上危險的電壓或能量、進行維修時務必小心。

Warnung

Wenn das System in Betrieb ist, treten auf der Rückwandplatine gefährliche Spannungen oder Energien auf. Vorsicht bei der Wartung.

¡Advertencia!

Cuando el sistema está en funcionamiento, el voltaje del plano trasero es peligroso. Tenga cuidado cuando lo revise.

Attention

Lorsque le système est en fonctionnement, des tensions électriques circulent sur le fond de panier. Prendre des précautions lors de la maintenance.

מתח בפנל האחורי

אזהרה!

קיימת סכנת מתח בפנל האחורי בזמן תפעול המערכת. יש להיזהר במהלך העבודה.

هناك خطر من التيار الكهربائي أو الطاقة المتجددة على اللوحة
عندما يكون النظام يعمل كه حذرا عند خدمة هذا الجهاز

경고!

시스템이 동작 중일 때 후면판 (Backplane)에는 위험한 전압이나 에너지가 발생 합니다.
서비스 작업 시 주의하십시오.

Waarschuwing

Een gevaarlijke spanning of energie is aanwezig op de backplane wanneer het systeem in gebruik is. Voorzichtigheid is geboden tijdens het onderhoud.

Comply with Local and National Electrical Codes



Warning! Installation of the equipment must comply with local and national electrical codes.

地方および国の電気規格に準拠

機器の取り付けはその地方および国の電気規格に準拠する必要があります。

警告

设备安装必须符合本地与本国电气法规。

警告

設備安裝必須符合本地與本國電氣法規。

Warnung

Die Installation der Geräte muss den Sicherheitsstandards entsprechen.

¡Advertencia!

La instalación del equipo debe cumplir con las normas de electricidad locales y nacionales.

Attention

L'équipement doit être installé conformément aux normes électriques nationales et locales.

תיאום חוקי החשמל הארצי

אזהרה!

התקנת הציוד חייבת להיות תואמת לחוקי החשמל המקומיים והארציים.

تركيب المعدات الكهربائية يجب أن يمتثل للقوايه المحلية والبطية المتعلقة
بالكهرباء

경고!

현 지역 및 국가의 전기 규정에 따라 장비를 설치해야 합니다.

Waarschuwing

Bij installatie van de apparatuur moet worden voldaan aan de lokale en nationale elektriciteitsvoorschriften.

Product Disposal



Warning! Ultimate disposal of this product should be handled according to all national laws and regulations.

製品の廃棄

この製品を廃棄処分する場合、国の関係する全ての法律・条例に従い処理する必要があります。

警告

本产品的废弃处理应根据所有国家的法律和规章进行。

警告

本產品的廢棄處理應根據所有國家的法律和規章進行。

Warnung

Die Entsorgung dieses Produkts sollte gemäß allen Bestimmungen und Gesetzen des Landes erfolgen.

¡Advertencia!

Al deshacerse por completo de este producto debe seguir todas las leyes y reglamentos nacionales.

Attention

La mise au rebut ou le recyclage de ce produit sont généralement soumis à des lois et/ou directives de respect de l'environnement. Renseignez-vous auprès de l'organisme compétent.

סילוק המוצר

אזהרה!

סילוק סופי של מוצר זה חייב להיות בהתאם להנחיות וחוקי המדינה.

التخلص النهائي من هذا المنتج ينبغي التعامل معه وفقا لجميع القوانين واللوائح الوطنية عند

경고!

이 제품은 해당 국가의 관련 법규 및 규정에 따라 폐기되어야 합니다.

Waarschuwing

De uiteindelijke verwijdering van dit product dient te geschieden in overeenstemming met alle nationale wetten en reglementen.

Hot Swap Fan Warning



Warning! Hazardous moving parts. Keep away from moving fan blades. The fans might still be turning when you remove the fan assembly from the chassis. Keep fingers, screwdrivers, and other objects away from the openings in the fan assembly's housing.

ファン・ホットスワップの警告

警告!回転部品に注意。運転中は回転部(羽根)に触れないでください。シャーシから冷却ファン装置を取り外した際、ファンがまだ回転している可能性があります。ファンの開口部に、指、ドライバー、およびその他のものを近づけないで下さい。

警告!

警告! 危險的可移動性零件。請務必與轉動的風扇葉片保持距離。當您從機架移除風扇裝置，風扇可能仍在轉動。小心不要將手指、螺絲起子和其他物品太靠近風扇

警告

危險的可移動性零件。請務必與轉動的風扇葉片保持距離。當您從機架移除風扇裝置，風扇可能仍在轉動。小心不要將手指、螺絲起子和其他物品太靠近風扇。

Warnung

Gefährlich Bewegende Teile. Von den bewegenden Lüfterblätter fern halten. Die Lüfter drehen sich u. U. noch, wenn die Lüfterbaugruppe aus dem Chassis genommen wird. Halten Sie Finger, Schraubendreher und andere Gegenstände von den Öffnungen des Lüftergehäuses entfernt.

¡Advertencia!

Riesgo de piezas móviles. Mantener alejado de las aspas del ventilador. Los ventiladores podran dar vuelta cuando usted quite el montaje del ventilador del chasis. Mantenga los dedos, los destornilladores y todos los objetos lejos de las aberturas del ventilador

Attention

Pieces mobiles dangereuses. Se tenir a l'écart des lames du ventilateur Il est possible que les ventilateurs soient toujours en rotation lorsque vous retirerez le bloc ventilateur du châssis. Prenez garde à ce que doigts, tournevis et autres objets soient éloignés du logement du bloc ventilateur.

אזהרה!

חלקים נעים מסוכנים. התרחק מלהבי המאוורר בפעולה כאשר מסירים את חלקי המאוורר מהמארז, יתכן והמאווררים עדיין עובדים. יש להרחיק למרחק בטוח את האצבעות וכלי עבודה שונים מהפתחים בתוך המאוורר

تحذير! أجزاء متحركة خطيرة. ابتعد عن شفرات المروحة المتحركة. من الممكن أن المراوح لا تزال تدور عند إزالة كتلة المروحة من الهيكل يجب إبقاء الأصابع ومفكات البراغي وغيرها من الأشياء بعيدا عن الفتحات في كتلة المروحة

경고!

움직이는 위험한 부품. 회전하는 송풍 날개에 접근하지 마세요. 새시로부터 팬 조립품을 제거할 때 팬은 여전히 회전하고 있을 수 있습니다. 팬 조립품 외관의 열려있는 부분들로부터 손가락 및 스크류드라이버, 다른 물체들이 가까이 하지 않도록 배치해 주십시오.

Waarschuwing

Gevaarlijk bewegende onderdelen. Houd voldoende afstand tot de bewegende ventilatorbladen. Het is mogelijk dat de ventilator nog draait tijdens het verwijderen van het ventilatorsamenstel uit het chassis. Houd uw vingers, schroevendraaiers en eventuele andere voorwerpen uit de buurt van de openingen in de ventilatorbehuizing.

Power Cable and AC Adapter



Warning! When installing the product, use the provided or designated connection cables, power cables and AC adaptors. Using any other cables and adaptors could cause a malfunction or a fire. Electrical Appliance and Material Safety Law prohibits the use of UL or CSA -certified cables (that have UL/CSA shown on the code) for any other electrical devices than products designated by Supermicro only.

電源コードとACアダプター

製品を設置する場合、提供または指定および購入された接続ケーブル、電源コードとACアダプターを、該当する地域の条例や安全基準に適合するコードサイズやプラグと共に使用下さい。他のケーブルやアダプタを使用すると故障や火災の原因になることがあります。

電気用品安全法は、ULまたはCSA認定のケーブル(UL/CSEマークがコードに表記)を Supermicro が指定する製品以外に使用することを禁止しています。

警告

安装此产品时,请使用本身提供的或指定的或采购的连接线,电源线和电源适配器。包含遵照当地法规和安全要求的合规的电源线尺寸和插头。使用其它线材或适配器可能会引起故障或火灾。除了Supermicro所指定的产品,电气用品和材料安全法律规定禁止使用未经UL或CSA认证的线材。(线材上会显示UL/CSA符号)。

警告

安裝此產品時,請使用本身提供的或指定的或採購的連接線,電源線和電源適配器。包含遵照當地法規和安全要求的合規的電源線尺寸和插頭。使用其它線材或適配器可能會引起故障或火災。除了Supermicro所指定的產品,電氣用品和材料安全法律規定禁止使用未經UL或CSA認證的線材。(線材上會顯示UL/CSA符號)。

Warnung

Nutzen Sie beim Installieren des Produkts ausschließlich die von uns zur Verfügung gestellten Verbindungskabeln, Stromkabeln und/oder Adapter, die Ihre örtlichen Sicherheitsstandards einhalten. Der Gebrauch von anderen Kabeln und Adapter können Fehlfunktionen oder Feuer verursachen. Die Richtlinien untersagen das Nutzen von UL oder CAS zertifizierten Kabeln (mit UL/CSA gekennzeichnet), an Geräten oder Produkten die nicht mit Supermicro gekennzeichnet sind.

¡Advertencia!

Cuando instale el producto, utilice la conexión provista o designada o procure cables, Cables de alimentación y adaptadores de CA que cumplan con los códigos locales y los requisitos de seguridad, incluyendo el tamaño adecuado del cable y el enchufe. El uso de otros cables y adaptadores podría causar un mal funcionamiento o un incendio. La Ley de Seguridad de Aparatos Eléctricos y de Materiales prohíbe El uso de cables certificados por UL o CSA (que tienen el certificado UL / CSA en el código) para cualquier otros dispositivos eléctricos que los productos designados únicamente por Supermicro.

Attention

Lors de l'installation du produit, utilisez les cables de connection fournis ou désigné ou achetez des cables, cables de puissance et adaptateurs respectant les normes locales et les conditions de securite y compris les tailles de cables et les prises electriques appropries. L'utilisation d'autres cables et adaptateurs peut provoquer un dysfonctionnement ou un incendie. Appareils électroménagers et la Loi sur la Sécurité Matériel interdit l'utilisation de câbles certifiés- UL ou CSA (qui ont UL ou CSA indiqué sur le code) pour tous les autres appareils électriques sauf les produits désignés par Supermicro seulement.

AC כבלים חשמליים ומתאמי

אזהרה!

אשר נרכשו או הותאמו לצורך ההתקנה, ואשר הותאמו לדרישות AC כאשר מתקינים את המוצר, יש להשתמש בכבלים, ספקים ומתאמים הבטיחות המקומיות, כולל מידה נכונה של הכבל והתקע. שימוש בכל כבל או מתאם מסוג אחר, עלול לגרום לתקלה או קצר חשמלי. בהתאם כאשר מופיע עליהם קוד) UL-CSA או ב UL - לחוקי השימוש במכשירי החשמל וחוקי הבטיחות, קיים איסור להשתמש בכבלים המוסמכים ב Supermicro עבור כל מוצר חשמלי אחר, אלא רק במוצר אשר הותאם ע"י (UL/CSA) של

עند تركيب المنتج، قم باستخدام التوصيلات المتوفرة أو المحددة أو قم بشراء الكابلات الكهربائية ومحوّلات التيار المتردد مع الالتزام بقوانين ومتطلبات السلامة المحلية بما في ذلك حجم الموصل والقابس السليم. استخدام أي كابلات ومحوّلات أخرى قد يتسبب في عطل أو حريق. يحظر قانون السلامة للأجهزة الكهربائية والمعدات استخدام الكابلات المعتمدة Supermicro مع أي معدات أخرى غير المنتجات المعينة والمحددة من قبل (UL/CSA) والتي تحمل علامة CSA أو UL من قبل

전원 케이블 및 AC 어댑터

경고! 제품을 설치할 때 현지 코드 및 적절한 굵기의 코드와 플러그를 포함한 안전 요구 사항을 준수하여 제공되거나 지정된 연결 혹은 구매 케이블, 전원 케이블 및 AC 어댑터를 사용하십시오.

다른 케이블이나 어댑터를 사용하면 오작동이나 화재가 발생할 수 있습니다. 전기 용품 안전법은 UL 또는 CSA 인증 케이블 (코드에 UL / CSA가 표시된 케이블)을 Supermicro가 지정한 제품 이외의 전기 장치에 사용하는 것을 금지합니다.

Stroomkabel en AC-Adapter

Waarschuwing! Bij het aansluiten van het Product uitsluitend gebruik maken van de geleverde Kabels of een andere geschikte aan te schaffen Aansluitmethode, deze moet altijd voldoen aan de lokale voorschriften en veiligheidsnormen, inclusief de juiste kabeldikte en stekker. Het gebruik van niet geschikte Kabels en/of Adapters kan een storing of brand veroorzaken. Wetgeving voor Elektrische apparatuur en Materiaalveiligheid verbied het gebruik van UL of CSA -gecertificeerde Kabels (met UL/CSA in de code) voor elke andere toepassing dan de door Supermicro hiervoor beoogde Producten.

Appendix C

System Specifications

Processors

Supports dual Intel® Xeon® 81xx/61xx/51xx/41xx/31xx and 82xx/62xx/52xx/42xx/32xx series (Socket P) processors which offer three Intel® UltraPath Interconnects (UPI) of up to 10.4 GT/s.

Note: Please refer to the motherboard specifications pages on our website for updates to supported processors.

Chipset

Intel PCH C621 chipset

BIOS

128 Mb AMI® Flash ROM

Memory

Supports up to 6 TB of NVDIMM, 3DS Load Reduced DIMM (3DS LRDIMM), and 3DS Registered DIMM (3DS RDIMM) DDR4 (288-pin) ECC of up to 2933/2666 MHz modules in 24 slots.

SATA Controller

On-chip (Intel PCH C621) controller

Drive Bays

24 3.5" mid-chassis and two rear mounted hot-swap drive bays to house SAS3/SATA4/NVMe drives

PCI Expansion Slots

Supports the following expansion slots:

- One PCI-E 3.0 x16 SIOM networking slot supported by CPU1
- One PCI-E 3.0 x8+x8 SAS3 AOM slot for mezzanine card supported by CPU1
- One PCI-E 3.0 x8 slot supported by CPU2 (CPU2 Slot1)
- Two PCI-E 3.0 x16 slots supported by CPU2 (CPU2 Slot2/CPU2 Slot3)

Motherboard

X11DSC+

Chassis

SC826SE1C4-R1K62; 2U Rackmount, (WxHxD) 17.2 x 3.5 x 30.7-in (437 x 89 x 780-mm)

System Cooling

Up to five 8-cm PWM fans

Power Supply

Model: PWS-1K62A-1R

AC Input Voltages: 90-127/200-264 VAC

Rated Input Current: 13-9A (100-127V)/10-8A (200-240V)

Rated Input Frequency: 47-63 Hz

Rated Output Power: 1600 Watt

Rated Output Voltages: 100-127V: +12V (83.3A), +12Vsb (2.1A); 200-240V: +12V (133A), +12Vsb (2.1A)

Operating Environment

Operating Temperature: 10° to 35° C (50° to 95° F)

Non-operating Temperature: -40° to 60° C (-40° to 140° F)

Operating Relative Humidity: 8% to 90% (non-condensing)

Non-operating Relative Humidity: 5% to 95% (non-condensing)

Regulatory Compliance

Electromagnetic Emissions: FCC Class A, EN 55032 Class A, EN 61000-3-2/3-3, CISPR 32 Class A

Electromagnetic Immunity: EN 55024/CISPR 24, (EN 61000-4-2, EN 61000-4-3, EN 61000-4-4, EN 61000-4-5, EN 61000-4-6, EN 61000-4-8, EN 61000-4-11), CNS14336-1, CNS13438, GB4943.1-2011, GB9254-2008(Class A) and GB17625.1-2012

Safety: CSA/EN/IEC/UL 60950-1 Compliant, UL or CSA Listed (USA and Canada), CE Marking (Europe)

Other: VCCI-CISPR 32 and AS/NZS CISPR 32

Environmental: Directive 2011/65/EU and Delegated Directive (EU) 2015/863 and Directive 2012/19/EU

Perchlorate Warning

California Best Management Practices Regulations for Perchlorate Materials: This Perchlorate warning applies only to products containing CR (Manganese Dioxide) Lithium coin cells. "Perchlorate Material-special handling may apply. See www.dtsc.ca.gov/hazardouswaste/perchlorate"

Appendix D

UEFI BIOS Recovery

Warning: Do not upgrade the BIOS unless your system has a BIOS-related issue. Flashing the wrong BIOS can cause irreparable damage to the system. In no event shall Supermicro be liable for direct, indirect, special, incidental, or consequential damages arising from a BIOS update. If you need to update the BIOS, do not shut down or reset the system while the BIOS is updating to avoid possible boot failure.

D.1 Overview

The Unified Extensible Firmware Interface (UEFI) provides a software-based interface between the operating system and the platform firmware in the pre-boot environment. The UEFI specification supports an architecture-independent mechanism that will allow the UEFI OS loader stored in an add-on card to boot the system. The UEFI offers clean, hands-off management to a computer during system boot.

D.2 Recovering the UEFI BIOS Image

A UEFI BIOS flash chip consists of a recovery BIOS block and a main BIOS block (a main BIOS image). The recovery block contains critical BIOS codes, including memory detection and recovery codes for the user to flash a healthy BIOS image if the original main BIOS image is corrupted. When the system power is turned on, the recovery block codes execute first. Once this process is complete, the main BIOS code will continue with system initialization and the remaining POST (Power-On Self-Test) routines.

Note 1: Follow the BIOS recovery instructions below for BIOS recovery when the main BIOS block crashes.

Note 2: When the BIOS recovery block crashes, you will need to follow the procedures to make a Returned Merchandise Authorization (RMA) request. (For a RMA request, please see section 3.5 for more information). Also, you may use the Supermicro Update Manager (SUM) Out-of-Band (OOB) (https://www.supermicro.com.tw/products/nfo/SMS_SUM.cfm) to reflash the BIOS.

D.3 Recovering the Main BIOS Block with a USB Device

This feature allows the user to recover the main BIOS image using a USB-attached device without additional utilities used. A USB flash device such as a USB Flash Drive, or a USB CD/DVD ROM/RW device can be used for this purpose. However, a USB Hard Disk drive cannot be used for BIOS recovery at this time.

The file system supported by the recovery block is FAT (including FAT12, FAT16, and FAT32) which is installed on a bootable or non-bootable USB-attached device. However, the BIOS

might need several minutes to locate the SUPER.ROM file if the media size becomes too large due to the huge volumes of folders and files stored in the device.

To perform UEFI BIOS recovery using a USB-attached device, follow the instructions below.

1. Using a different machine, copy the "Super.ROM" binary image file into the Root "\" directory of a USB device or a writable CD/DVD.

Note: If you cannot locate the "Super.ROM" file in your drive disk, visit our website at www.supermicro.com to download the BIOS package. Extract the BIOS binary image into a USB flash device and rename it "Super.ROM" for the BIOS recovery use.

2. Insert the USB device that contains the new BIOS image ("Super.ROM") into your USB drive and reset the system when the following screen appears.
3. After locating the healthy BIOS binary image, the system will enter the BIOS Recovery menu as shown below.



Note: At this point, you may decide if you want to start the BIOS recovery. If you decide to proceed with BIOS recovery, follow the procedures below.

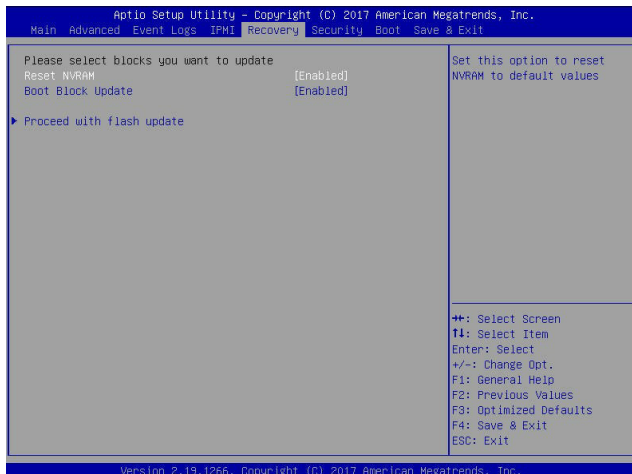

4. When the screen as shown above displays, use the arrow keys to select the item "Proceed with flash update" and press the <Enter> key. You will see the BIOS recovery progress as shown in the screen below.

Note: Do not interrupt the BIOS flashing process until it has completed.

5. After the BIOS recovery process is complete, press any key to reboot the system.
6. Using a different system, extract the BIOS package into a USB flash drive.

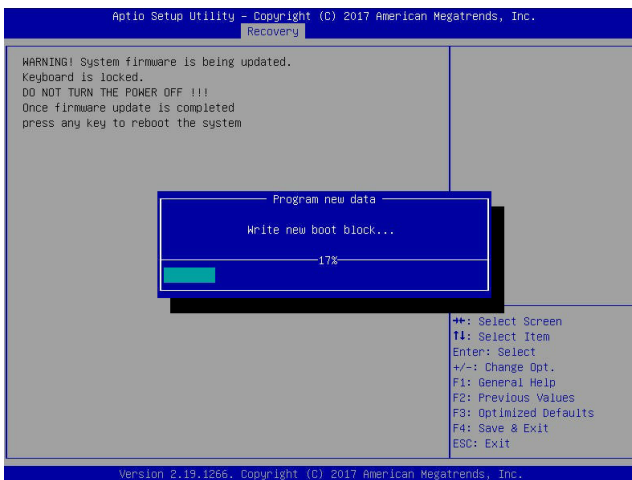

- Press continuously during system boot to enter the BIOS Setup utility. From the top of the tool bar, select Boot to enter the submenu. From the submenu list, select Boot

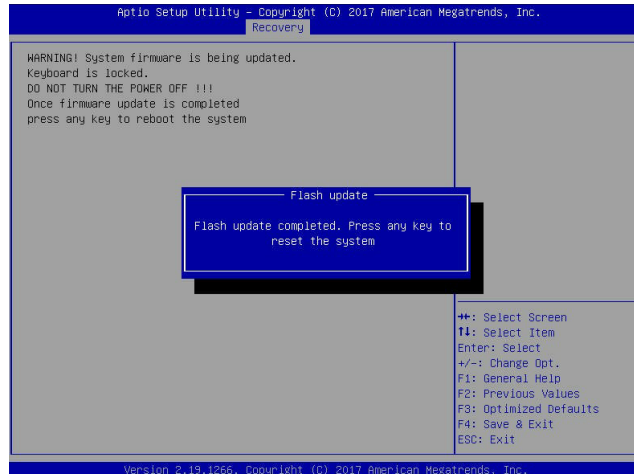

Option #1 as shown below. Then, set Boot Option #1 to [UEFI AP:UEFI: Built-in EFI Shell]. Press <F4> to save the settings and exit the BIOS Setup utility.

- When the UEFI Shell prompt appears, type `fs#` to change the device directory path. Go to the directory that contains the BIOS package you extracted earlier from Step 6. Enter `flash.nsh BIOSname.###` at the prompt to start the BIOS update process.

Note: Do not interrupt this process until the BIOS flashing is complete.

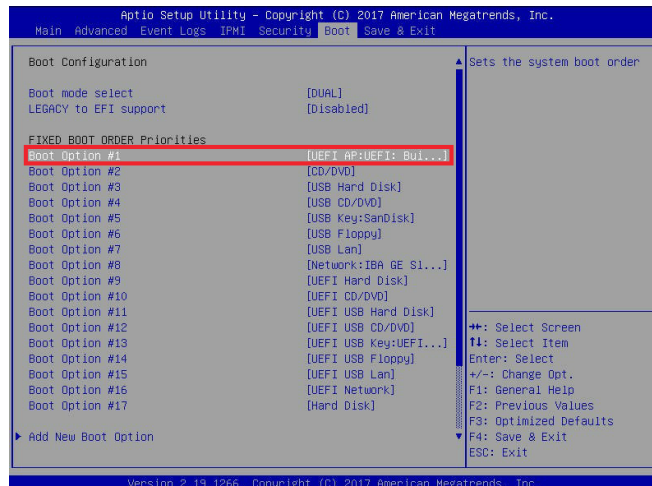

9. The screen above indicates that the BIOS update process is complete. When you see the screen above, unplug the AC power cable from the power supply, clear CMOS, and plug the AC power cable in the power supply again to power on the system.

```

UEFI Interactive Shell v2.1
EDK II
UEFI v2.50 (American Megatrends, 0x0005000C)
Mapping table
FS0: Alias(s):HD09081:BLK1:
      PciRoot(0x0)/Pci(0x14,0x0)/USB(0x11,0x0)/HD(1,MBR,0x3791072,0x800,0x1
      049592)
BLK0: Alias(s):
      PciRoot(0x0)/Pci(0x14,0x0)/USB(0x11,0x0)
Press F8C to 4 seconds to skip startup.nsh or any other key to continue.
Shell> f80c
FS0:\> cd #FUD05
FS0:\#FUD05\> cd SHJPM2_03162017
FS0:\#FUD05\SHJPM2_03162017> flash.nsh X11DU7_314_

```

10. Press continuously to enter the BIOS Setup utility.

```

Done.
[ Access CMOS Port Ex ]
<Read>
Index 0x51: 0x10

Done.
*****
* Program BIOS and ME (Including FDT) regions...
*
*****
| AMI Firmware Update Utility v5.09.01.1317 |
| Copyright (C)2017 American Megatrends Inc. All Rights Reserved. |
*****
CPUID = 90652

Reading flash ..... done
- ME Data Size checking - ok
- FFS checks/sums ..... ok
- Check RomLayout ..... Ok.
Erasing Boot Block ..... done
Updating Boot Block ..... done
Verifying Boot Block ..... done
Erasing Main Block ..... 0x0132000 (0%)

```

11. Press <F3> to load the default settings.
12. After loading the default settings, press <F4> to save the settings and exit the BIOS Setup utility.

```

Verifying NCB Block ..... done
- Update success for FDR
- Update success for IE. -
- Successful update Recovery Loader to OPRX!!
- Successful Update MFSB!!-
- Successful Update FTFR!!-
- Successful Update MFS, IVB1 and IVB2!!
- Successful update FLOS and UTOX!!
- ME Entire Image update success !!
WARNING : System must power-off to have the changes take effect!
Moving F50:\#FUD05\SHJPM2_03162017\Fdtx64.efi -> F50:\#FUD05\SHJPM2_03162017\F
dt.smc
- [ok]
Moving F50:\#FUD05\SHJPM2_03162017\Fuef1x64.efi -> F50:\#FUD05\SHJPM2_0316201
7\Fuef1.smc
- [ok]
*****
* Please ignore this 'Shell: Cannot read from file - Device Error'
* warning message due to it does not impact flashing process.
*
*****
Deleting 'f50:\startup.nsh'
Delete successful.
FS0:\>

```