



**Hewlett Packard
Enterprise**

HPE Synergy 660 Gen10 Compute Module User Guide

Abstract

This document is for the person who installs, administers, and troubleshoots server blades. Hewlett Packard Enterprise assumes you are qualified in the servicing of computer equipment and trained in recognizing hazards in products with hazardous energy levels.

Part Number: 876828-006
Published: June 2019
Edition: 6

Notices

The information contained herein is subject to change without notice. The only warranties for Hewlett Packard Enterprise products and services are set forth in the express warranty statements accompanying such products and services. Nothing herein should be construed as constituting an additional warranty. Hewlett Packard Enterprise shall not be liable for technical or editorial errors or omissions contained herein.

Confidential computer software. Valid license from Hewlett Packard Enterprise required for possession, use, or copying. Consistent with FAR 12.211 and 12.212, Commercial Computer Software, Computer Software Documentation, and Technical Data for Commercial Items are licensed to the U.S. Government under vendor's standard commercial license.

Links to third-party websites take you outside the Hewlett Packard Enterprise website. Hewlett Packard Enterprise has no control over and is not responsible for information outside the Hewlett Packard Enterprise website.

Acknowledgments

Intel[®], Itanium[®], Pentium[®], Xeon[®], Intel Inside[®], and the Intel Inside logo are trademarks of Intel Corporation in the U.S. and other countries.

Microsoft[®] and Windows[®] are either registered trademarks or trademarks of Microsoft Corporation in the United States and/or other countries.

Adobe[®] and Acrobat[®] are trademarks of Adobe Systems Incorporated.

Java[®] and Oracle[®] are registered trademarks of Oracle and/or its affiliates.

UNIX[®] is a registered trademark of The Open Group.

Contents

Component identification.....	6
Front panel LEDs and buttons.....	6
Front panel components.....	7
Serial label pull tab information.....	8
Drive numbering.....	8
Hot-plug drive LED definitions.....	9
NVMe SSD LED definitions.....	10
SFF flash adapter components and LED definitions.....	12
System board components.....	13
System maintenance switch.....	14
Processor, heatsink, and socket components.....	15
Mezzanine connector definitions.....	15
DIMM slot locations.....	16
DIMM label identification.....	17
NVDIMM identification.....	19
NVDIMM LED identification.....	20
HPE Persistent Memory module label identification.....	21
Component and LED identification for HPE Synergy hardware.....	22
Operations.....	23
Powering up the compute module	23
Powering down the compute module	23
Removing the compute module	23
Removing the access panel.....	24
Installing the access panel.....	25
Removing and replacing a drive blank.....	25
Removing the DIMM baffle.....	25
Installing the DIMM baffles.....	26
Removing the front panel/drive cage assembly.....	27
Installing the front panel/drive cage assembly.....	28
Setup.....	29
Installation overview.....	29
Installing the compute module	29
Installing the compute module options.....	30
Completing the configuration.....	31
Hardware options installation.....	32
Introduction.....	32
Installing the drive option.....	32
Installing the SFF flash adapter option.....	34
Installing the M.2 SSD flash drive.....	35
Installing the controller option.....	35
HPE Smart Storage Battery.....	36
HPE Smart Storage Hybrid Capacitor.....	36
Minimum firmware versions.....	37

Installing the energy pack option.....	37
Installing the mezzanine card options.....	39
Memory options.....	40
DIMM and NVDIMM population information.....	40
DIMM-processor compatibility.....	40
HPE SmartMemory speed information.....	40
Installing a DIMM.....	41
HPE 16GB NVDIMM option.....	41
HPE Persistent Memory option.....	45
Installing the processor heatsink option.....	50
HPE Trusted Platform Module 2.0 Gen10 option.....	52
Overview.....	52
HPE Trusted Platform Module 2.0 Guidelines.....	53
Installing and enabling the HPE TPM 2.0 Gen10 Kit.....	54
Cabling.....	59
Cabling resources.....	59
Energy pack option cabling.....	59
Standard drive backplane cabling.....	59
P416ie-m Smart Array Controller cabling.....	60
Removing and replacing the system battery.....	61
Electrostatic discharge.....	63
Preventing electrostatic discharge.....	63
Grounding methods to prevent electrostatic discharge.....	63
Specifications.....	64
Environmental specifications	64
Physical specifications.....	64
Documentation and troubleshooting resources for HPE Synergy.....	65
HPE Synergy documentation.....	65
HPE Synergy Configuration and Compatibility Guide.....	65
HPE Synergy Frame Link Module User Guide.....	65
HPE OneView User Guide and Help for HPE Synergy.....	65
HPE OneView Global Dashboard User Guide and Help.....	65
HPE Synergy Image Streamer User Guide.....	65
HPE Synergy Image Streamer GitHub.....	66
HPE Synergy Software Overview Guide.....	66
HPE OneView for Synergy Firmware and Driver Update Guide.....	66
HPE OneView Support Matrix for HPE Synergy.....	66
HPE Synergy Image Streamer Support Matrix.....	66
HPE Synergy Firmware Comparison Tool	66
HPE Synergy Upgrade Paths.....	66
HPE Synergy Glossary.....	67
HPE Synergy troubleshooting resources.....	67
Troubleshooting within HPE OneView.....	67
HPE Synergy Troubleshooting Guide.....	67
Error Message Guide for HPE ProLiant Gen10 servers and HPE Synergy.....	67
HPE OneView Help and HPE OneView API Reference.....	67

HPE Synergy QuickSpecs.....	67
HPE Synergy document overview (documentation map).....	68
Websites.....	70
Support and other resources.....	71
Accessing Hewlett Packard Enterprise Support.....	71
Accessing updates.....	71
Customer self repair.....	72
Remote support.....	72
Warranty information.....	72
Regulatory information.....	72
Documentation feedback.....	73

Component identification

Front panel LEDs and buttons

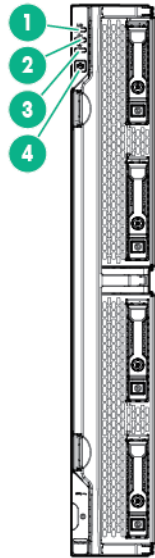

Item	Description	Status
1	UID LED	Solid blue = Activated Flashing blue (1 Hz/cycle per sec) = Remote management or firmware upgrade in progress Off = Deactivated
2	Health status LED	Solid green = Normal Flashing green (1 Hz/cycle per sec) = iLO is rebooting Flashing amber = System degraded Flashing red (1 Hz/cycle per sec) = System critical

Table Continued

Item	Description	Status
3	Mezzanine NIC status LED	<p>Solid green= Link on any Mezzanine NIC</p> <p>Flashing green= Activity on any Mezzanine NIC</p> <p>Off = No link or activity on any Mezzanine NIC</p>
4	Power On/Standby button and system power LED	<p>Solid green = System on</p> <p>Flashing green (1 Hz/cycle per sec) = Performing power on sequence</p> <p>Solid amber = System in standby</p> <p>Off = No power present¹</p>

¹ If all other LEDs are off, then no power is present to the compute module. (For example, facility power is not present, power cord is not attached, no power supplies are installed, power supply failure has occurred, or the compute module is not properly seated.) If the health LED is flashing green while the system power LED is off, the **Power On/Standby** button service is initializing or that an iLO reboot is in progress.

Front panel components

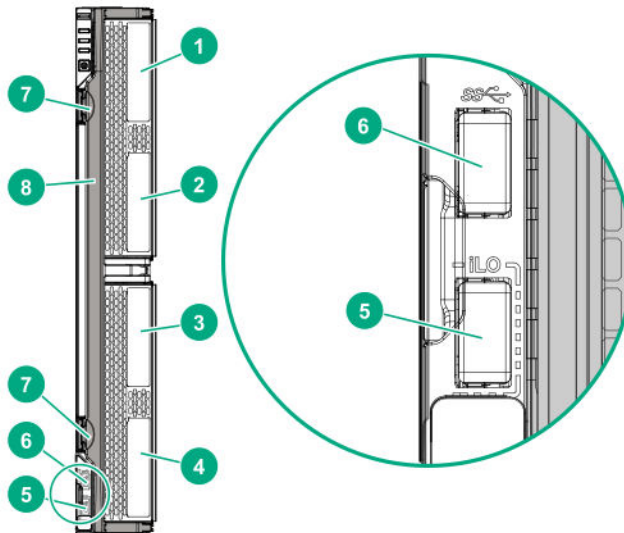

Item	Description
1	Drive Box 1, Drive bay 1 ¹
2	Drive Box 1, Drive bay 2 ¹
3	Drive Box 2, Drive bay 1 ¹
4	Drive Box 2, Drive bay 2 ¹

Table Continued

Item	Description
5	iLO Service Port (169.254.1.2) (located behind the Serial label pull tab)
6	External USB (located behind the Serial label pull tab)
7	Compute module handle release latch
8	Compute module handle

¹ If uFF drives (the SFF Flash Storage Adapter) are installed in the drive bays, the drive bay numbering is different. For more information, see [Drive numbering](#).

Serial label pull tab information

The serial label pull tab is located on the front panel of the compute module. To locate the serial label pull tab, see [Front panel components](#). The serial label pull tab provides the following information:

- Product serial number
- HPE iLO information
- QR code that points to mobile-friendly documentation

Drive numbering

Depending on the configuration, the drive bay numbering on this compute module will vary. Supported configurations on this compute module are shown in the following table.

Compute module model	Configuration	Drive support
SAS model	Standard backplane with embedded controller or supported controller option	Four SFF hot-plug SAS drive bays with support for up to 4 SFF HDDs or SSDs
SATA model	Chipset SATA with embedded controller or supported controller option	Four SFF hot-plug SATA drive bays with support for the following: <ul style="list-style-type: none"> • Up to 4 SFF SATA HDDs or SSDs • Up to 8 uFF SATA HDDs (with the SFF flash adapter for each 2 uFF drives)

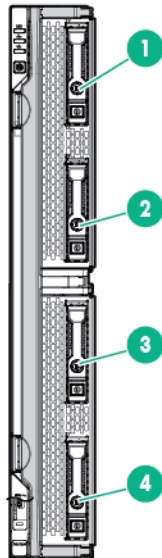

Item	SAS configuration	SATA configuration*	Expansion storage configuration
1	1	Drive box 1, drive bay 1 and 101	Drive box 1, drive bay 1
2	2	Drive box 1, drive bay 2 and 102	Drive box 1, drive bay 2
3	1	Drive box 2, drive bay 1 and 101	Drive box 2, drive bay 1
4	2	Drive box 2, drive bay 2 and 102	Drive box 2, drive bay 2

The driveless model is not shown, as it does not have drive bays and does support for any drives.

*SATA drives are supported only with the HPE Synergy 480 Gen9 Compute Module backplane.

Hot-plug drive LED definitions

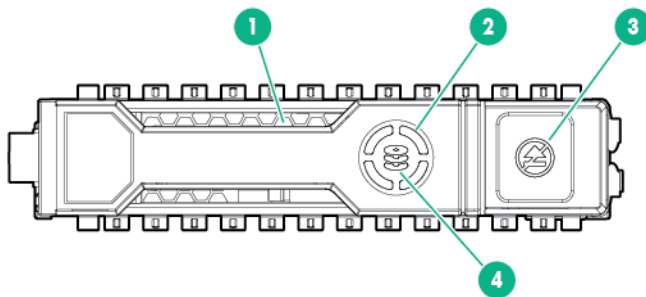

Item	LED	Status	Definition
1	Locate	Solid blue	The drive is being identified by a host application.
		Flashing blue	The drive carrier firmware is being updated or requires an update.

Table Continued

Item	LED	Status	Definition
2	Activity ring	Rotating green	Drive activity
		Off	No drive activity
3	Do not remove	Solid white	Do not remove the drive. Removing the drive causes one or more of the logical drives to fail.
		Off	Removing the drive does not cause a logical drive to fail.
4	Drive status	Solid green	The drive is a member of one or more logical drives.
		Flashing green	The drive is doing one of the following: <ul style="list-style-type: none"> • Rebuilding • Performing a RAID migration • Performing a strip size migration • Performing a capacity expansion • Performing a logical drive extension • Erasing • Spare part activation
		Flashing amber/green	The drive is a member of one or more logical drives and predicts the drive will fail.
		Flashing amber	The drive is not configured and predicts the drive will fail.
		Solid amber	The drive has failed.
		Off	The drive is not configured by a RAID controller or a spare drive.

NVMe SSD LED definitions

The NVMe SSD is a PCIe bus device. A device attached to a PCIe bus cannot be removed without allowing the device and bus to complete and cease the signal/traffic flow.

⚠ CAUTION: Do not remove an NVMe SSD from the drive bay while the Do not remove LED is flashing. The Do not remove LED flashes to indicate that the device is still in use. Removing the NVMe SSD before the device has completed and ceased signal/traffic flow can cause loss of data.

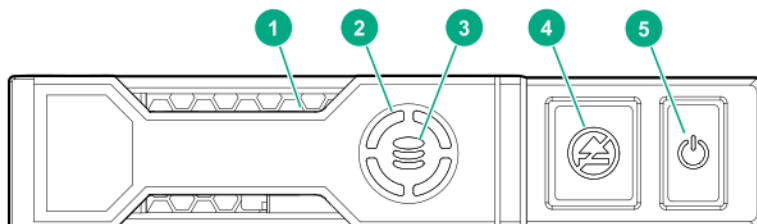

Item	LED	Status	Definition
1	Locate	Solid blue	The drive is being identified by a host application.
		Flashing blue	The drive carrier firmware is being updated or requires an update.
2	Activity ring	Rotating green	Drive activity
		Off	No drive activity
3	Drive status	Solid green	The drive is a member of one or more logical drives.
		Flashing green	The drive is doing one of the following: <ul style="list-style-type: none"> • Rebuilding • Performing a RAID migration • Performing a stripe size migration • Performing a capacity expansion • Performing a logical drive extension • Erasing
		Flashing amber/green	The drive is a member of one or more logical drives and predicts the drive will fail.
		Flashing amber	The drive is not configured and predicts the drive will fail.
		Solid amber	The drive has failed.
		Off	The drive is not configured by a RAID controller.
4	Do not remove	Solid white	Do not remove the drive. The drive must be ejected from the PCIe bus prior to removal.
		Flashing white	The drive ejection request is pending.
		Off	The drive has been ejected.
5	Power	Solid green	Do not remove the drive. The drive must be ejected from the PCIe bus prior to removal.
		Flashing green	The drive ejection request is pending.
		Off	The drive has been ejected.

SFF flash adapter components and LED definitions

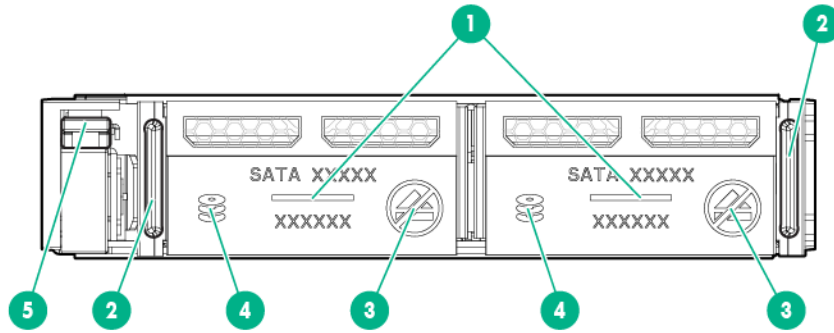

Item	Component	Description
1	Locate	<ul style="list-style-type: none"> Off—Normal Solid blue—The drive is being identified by a host application. Flashing blue—The drive firmware is being updated or requires an update.
2	uFF drive ejection latch	Removes the uFF drive when released.
3	Do not remove LED	<ul style="list-style-type: none"> Off—OK to remove the drive. Removing the drive does not cause a logical drive to fail. Solid white—Do not remove the drive. Removing the drive causes one or more of the logical drives to fail.
4	Drive status LED	<ul style="list-style-type: none"> Off—The drive is not configured by a RAID controller or a spare drive. Solid green—The drive is a member of one or more logical drives. Flashing green (4 Hz)—The drive is operating normally and has activity. Flashing green (1 Hz)—The drive is rebuilding, erasing, or performing a RAID migration, stripe size migration, capacity expansion, logical drive extension, or spare activation. Flashing amber/green (1 Hz)—The drive is a member of one or more logical drives that predicts the drive will fail. Solid amber—The drive has failed. Flashing amber (1 Hz)—The drive is not configured and predicts the drive will fail.
5	Adapter ejection release latch and handle	Removes the SFF flash adapter when released.

System board components

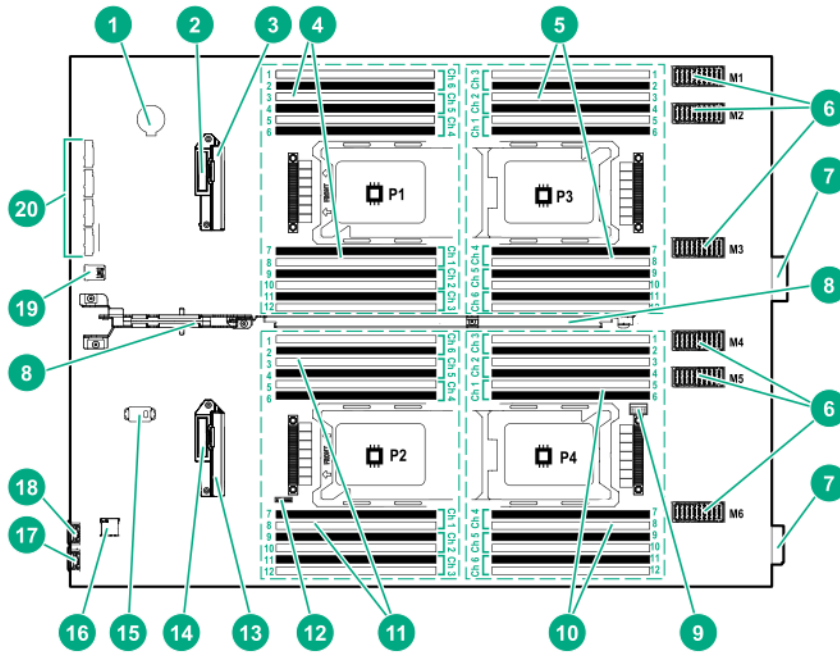

Item	Description
1	System battery
2	SATA interconnect 1
3	Drive backplane connector 1
4	P1 DIMM slots (12 each)
5	P3 DIMM slots (12 each)
6	Mezzanine connectors
7	Management/power connector (2)
8	Handle
9	Energy pack option connector
10	P4 DIMM slots (12 each)
11	P2 DIMM slots (12 each)
12	System maintenance switch
13	Drive backplane connector 2
14	SATA interconnect 2
15	TPM connector
16	MicroSD connector
17	iLO Service Port (169.254.1.2) (located behind the Serial label pull tab)

Table Continued

Item	Description
18	External USB (located behind the Serial label pull tab)
19	Internal USB 3.0 connector
20	M.2 connectors

System maintenance switch

Position	Default	Function
S1 ¹	Off	Off = HPE iLO security is enabled. On = HPE iLO security is disabled.
S2	Off	Off = System configuration can be changed. On = System configuration is locked.
S3	Off	Reserved
S4	Off	Reserved
S5 ¹	Off	Off = Power-on password is enabled. On = Power-on password is disabled.
S6 ^{1, 2}	Off	Off = No function On = Restore default manufacturing settings
S7	Off	Off = Set default boot mode to UEFI. On = Set default boot mode to legacy.
S8	—	Reserved
S9	—	Reserved
S10	—	Reserved
S11	—	Reserved
S12	—	Reserved

¹ You can access the redundant ROM by setting S1, S5, and S6 to On.

² When the system maintenance switch position 6 is set to the On position, the system is prepared to restore all configuration settings to their manufacturing defaults.

When the system maintenance switch position 6 is set to the On position and Secure Boot is enabled, some configurations cannot be restored. For more information, see Secure Boot configuration.

! **IMPORTANT:** Before using the S7 switch to change to Legacy BIOS Boot Mode, be sure the HPE Dynamic Smart Array B140i Controller is disabled. Do not use the B140i controller when the compute module is in Legacy BIOS Boot Mode.

Processor, heatsink, and socket components

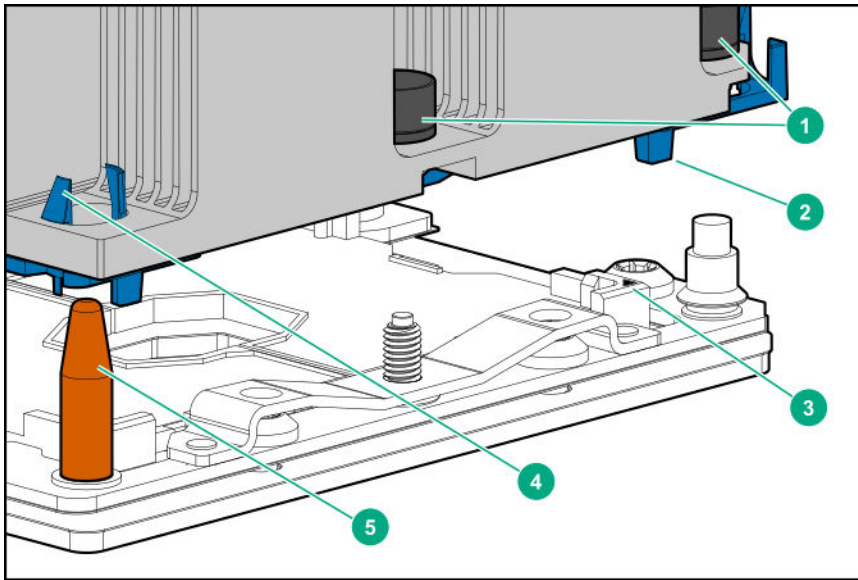

Item	Description
1	Heatsink nuts
2	Processor carrier
3	Pin 1 indicator ¹
4	Heatsink latch
5	Alignment post

¹ Symbol also on the processor and frame.

Mezzanine connector definitions

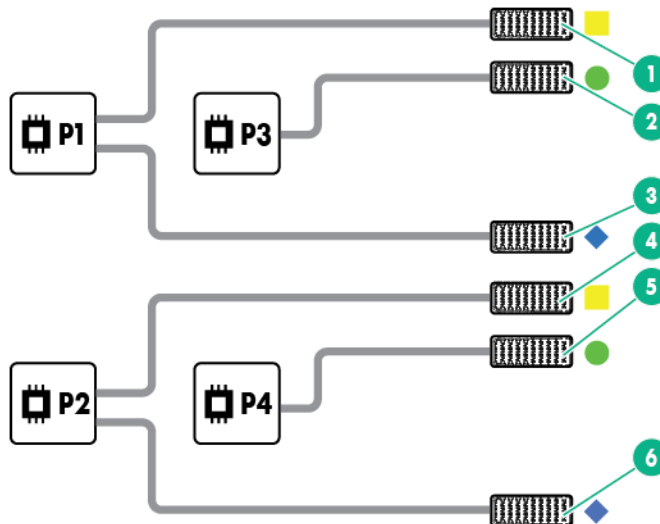

Item	Connector identification	Supported card types	Fabric	Supported ICM bays
1	Mezzanine connector 1 (M1)	Type C and Type D	1	ICM 1 and 4
2	Mezzanine connector 2 (M2) ¹	Type C and Type D	2	ICM 2 and 5
3	Mezzanine connector 3 (M3)	Type C only	3	ICM 3 and 6
4	Mezzanine connector 4 (M4)	Type C and Type D	1	ICM 1 and 4
5	Mezzanine connector 5 (M5) ²	Type C and Type D	2	ICM 2 and 5
6	Mezzanine connector 6 (M6)	Type C	3	ICM 3 and 6

¹ When installing a mezzanine option on mezzanine connector 2, processor 3 must be installed.

² When installing a mezzanine option on mezzanine connector 5, processor 4 must be installed.

DIMM slot locations

DIMM slots are numbered sequentially (1 through 12) for each processor. The supported AMP modes use the alpha assignments for population order, and the slot numbers designate the DIMM slot ID for spare replacement.

The colored slots indicate the slot order within each channel:

- White — First slot of a channel
- Black — Second slot of a channel

The arrow points to the front of the compute module.

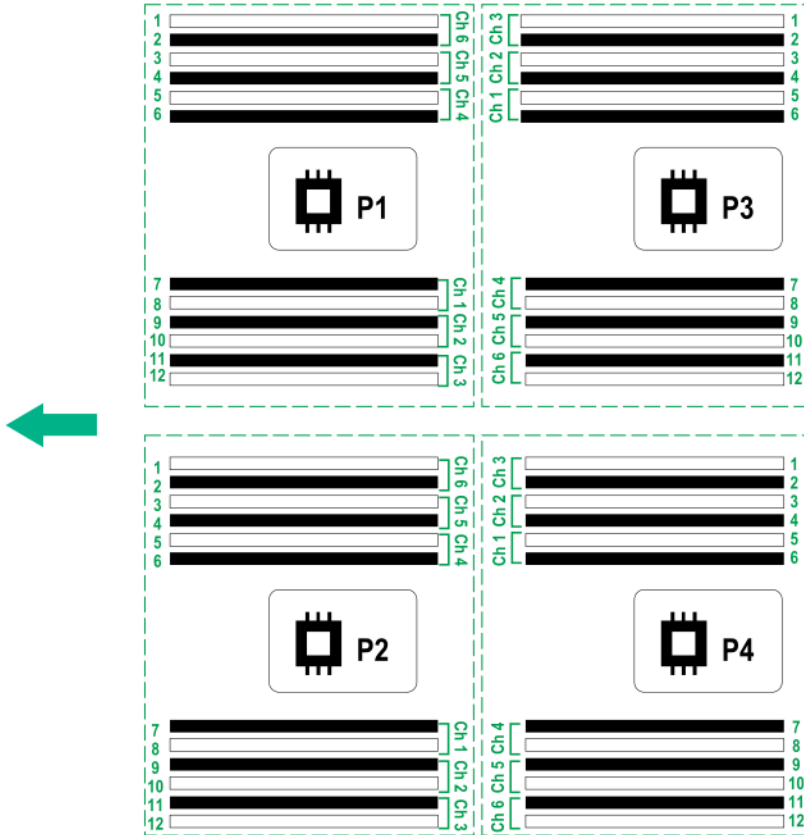

DIMM label identification

To determine DIMM characteristics, see the label attached to the DIMM. The information in this section helps you to use the label to locate specific information about the DIMM.

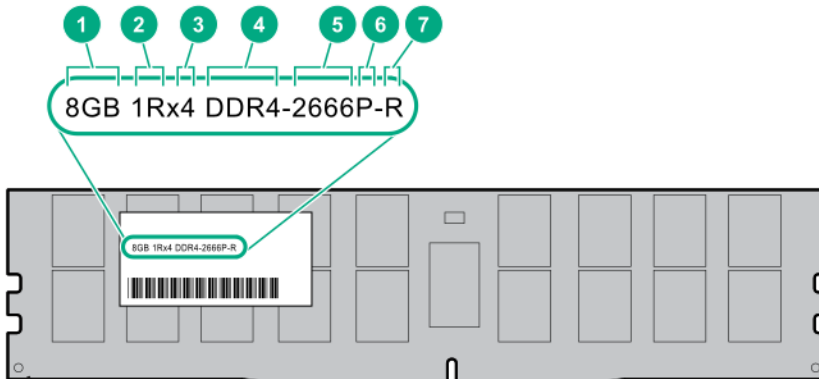

Item	Description	Example
1	Capacity	8 GB 16 GB 32 GB 64 GB 128 GB
2	Rank	1R = Single rank 2R = Dual rank 4R = Quad rank 8R = Octal rank
3	Data width on DRAM	x4 = 4-bit x8 = 8-bit x16 = 16-bit
4	Memory generation	PC4 = DDR4
5	Maximum memory speed	2133 MT/s 2400 MT/s 2666 MT/s 2933 MT/s
6	CAS latency	P = CAS 15-15-15 T = CAS 17-17-17 U = CAS 20-18-18 V = CAS 19-19-19 (for RDIMM, LRDIMM) V = CAS 22-19-19 (for 3DS TSV LRDIMM) Y = CAS 21-21-21 (for RDIMM, LRDIMM) Y = CAS 24-21-21 (for 3DS TSV LRDIMM)
7	DIMM type	R = RDIMM (registered) L = LRDIMM (load reduced) E = Unbuffered ECC (UDIMM)

For more information about product features, specifications, options, configurations, and compatibility, see the HPE DDR4 SmartMemory QuickSpecs on the Hewlett Packard Enterprise website (<http://www.hpe.com/support/DDR4SmartMemoryQS>).

NVDIMM identification

NVDIMM boards are blue instead of green. This change to the color makes it easier to distinguish NVDIMMs from DIMMs.

To determine NVDIMM characteristics, see the full product description as shown in the following example:

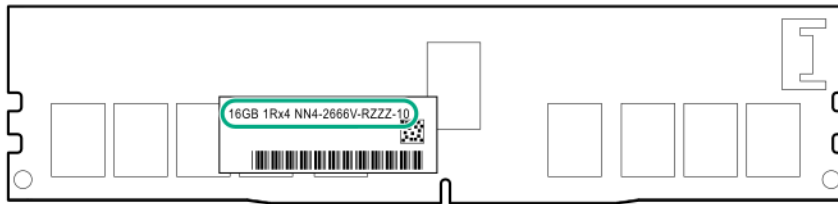
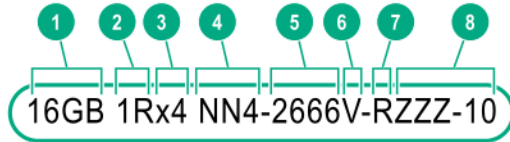

Item	Description	Definition
1	Capacity	16 GiB
2	Rank	1R (Single rank)
3	Data width per DRAM chip	x4 (4 bit)
4	Memory type	NN4=DDR4 NVDIMM-N
5	Maximum memory speed	2667 MT/s
6	Speed grade	V (latency 19-19-19)
7	DIMM type	RDIMM (registered)
8	Other	—

For more information about NVDIMMs, see the product QuickSpecs on the Hewlett Packard Enterprise website (<http://www.hpe.com/info/qs>).

NVDIMM 2D Data Matrix barcode

The 2D Data Matrix barcode is on the right side of the NVDIMM label and can be scanned by a cell phone or other device.

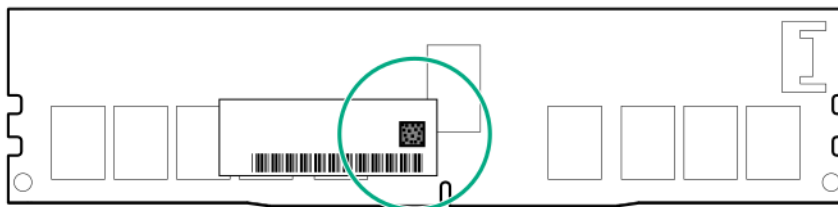

When scanned, the following information from the label can be copied to your cell phone or device:

- (P) is the module part number.
- (L) is the technical details shown on the label.
- (S) is the module serial number.

Example: (P)HMN82GR7AFR4N-VK (L)16GB 1Rx4 NN4-2666V-RZZZ-10(S)80AD-01-1742-11AED5C2

NVDIMM LED identification

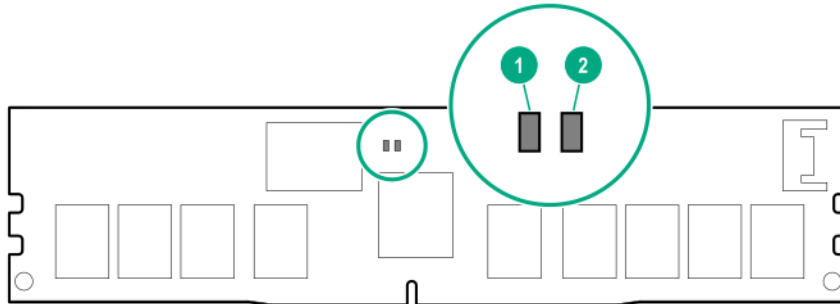

Item	LED description	LED color
1	Power LED	Green
2	Function LED	Blue

NVDIMM-N LED combinations

State	Definition	NVDIMM-N Power LED (green)	NVDIMM-N Function LED (blue)
0	AC power is on (12V rail) but the NVM controller is not working or not ready.	On	Off
1	AC power is on (12V rail) and the NVM controller is ready.	On	On
2	AC power is off or the battery is off (12V rail off).	Off	Off
3	AC power is on (12V rail) or the battery is on (12V rail) and the NVDIMM-N is active (backup and restore).	On	Flashing

NVDIMM Function LED patterns

For the purpose of this table, the NVDIMM-N LED operates as follows:

- Solid indicates that the LED remains in the on state.
- Flashing indicates that the LED is on for 2 seconds and off for 1 second.
- Fast-flashing indicates that the LED is on for 300 ms and off for 300 ms.

State	Definition	NVDIMM-N Function LED
0	The restore operation is in progress.	Flashing
1	The restore operation is successful.	Solid or On
2	Erase is in progress.	Flashing
3	The erase operation is successful.	Solid or On
4	The NVDIMM-N is armed, and the NVDIMM-N is in normal operation.	Solid or On
5	The save operation is in progress.	Flashing
6	The NVDIMM-N finished saving and battery is still turned on (12 V still powered).	Solid or On
7	The NVDIMM-N has an internal error or a firmware update is in progress. For more information about an NVDIMM-N internal error, see the IML.	Fast-flashing

HPE Persistent Memory module label identification

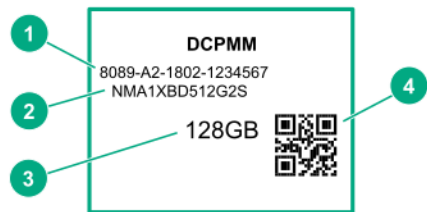

Item	Description	Example
1	Unique ID number	8089-A2-1802-1234567
2	Model number	NMA1XBD512G2S
3	Capacity	128 GB 256 GB 512 GB
4	QR code	Includes part number and serial number

For more information about product features, specifications, options, configurations, and compatibility, see the product QuickSpecs on the Hewlett Packard Enterprise website (<http://www.hpe.com/support/persistentmemoryQS>).

Component and LED identification for HPE Synergy hardware

For more information about component and LED identification for HPE Synergy components, see the product-specific maintenance and service guide or the *HPE Synergy 12000 Frame Setup and Installation Guide* in the [Hewlett Packard Enterprise Information Library](#).

Operations

Powering up the compute module

To power up the compute module, press the Power On/Standby button after the power button LED has turned amber.

Powering down the compute module

Before powering down the compute module for any upgrade or maintenance procedures, perform a backup of the system and all data. Then, shut down, as appropriate, applications and operating systems. A successful shutdown is indicated by the system power LED displaying amber.

❗ **IMPORTANT:** Always attempt a graceful shutdown before forcing a nongraceful shutdown. Application data can be lost when performing a nongraceful shutdown of applications and the OS.

Before proceeding, verify the following:

- The compute module is in standby mode by observing that the system power LED is amber.
- The UID LED is not flashing blue.

NOTE:

- When the compute module is in standby mode, auxiliary power is still being provided to the system.
 - If the UID LED is flashing blue, a remote session is in progress.
-

To power down the compute module, use one of the following methods:

- To perform a graceful shutdown of applications and the OS when powering down the compute module to standby mode, do one of the following:
 - Press and release the **Power On/Standby** button.
 - Select the Momentary press power off selection in HPE OneView.
 - Select the Momentary press virtual power button selection in HPE iLO.
- If a graceful shutdown fails to power down the compute module to standby mode when an application or OS stops responding, force a nongraceful shutdown of applications and the OS. Do one of the following:
 - Press and hold the **Power On/Standby** button for more than four seconds.
 - Select the Press and hold power off selection in HPE OneView.
 - Select the Press and hold virtual power button selection in HPE iLO.

Removing the compute module

Procedure

1. Identify the proper compute module.
2. **Power down the compute module.**

3. Remove the compute module.

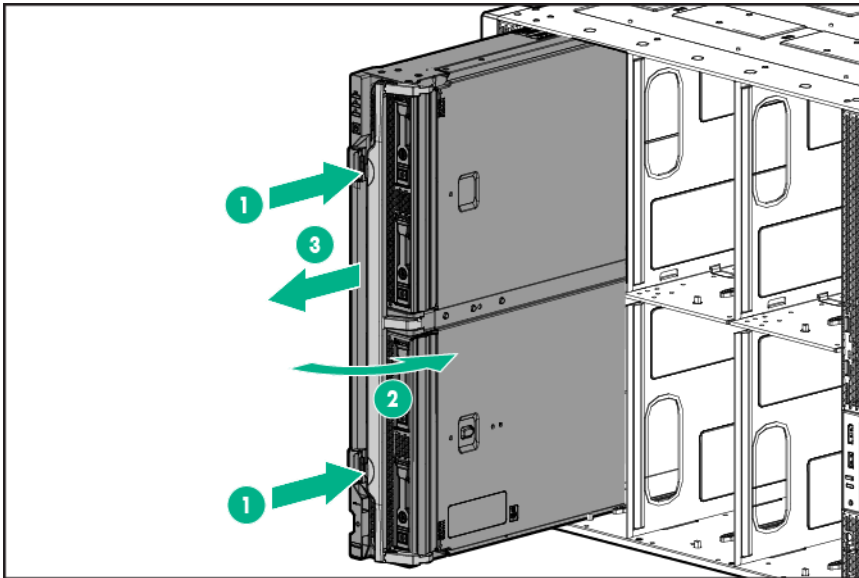

4. Place the compute module on a flat, level work surface.

⚠ WARNING: To reduce the risk of personal injury from hot surfaces, allow the drives and the internal system components to cool before touching them.

⚠ CAUTION: To prevent damage to electrical components, properly ground the compute module before beginning any installation procedure. Improper grounding can cause ESD.

Removing the access panel

Procedure

1. **Power down the compute module.**
2. **Remove the compute module.**
3. Place the compute module on a flat, level work surface.
4. Press the access panel release button.
5. Slide the access panel towards the rear of the compute module, and then lift the panel to remove it.

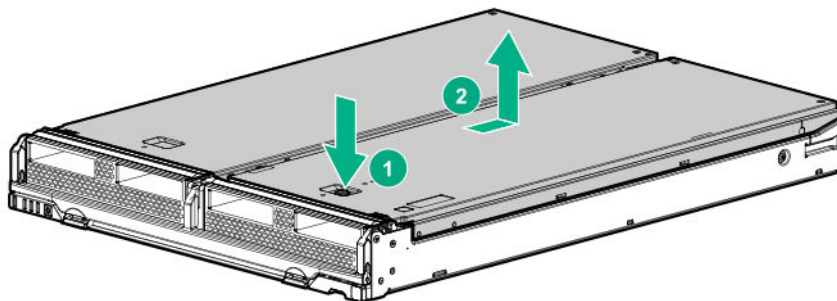

Installing the access panel

Procedure

1. Place the access panel on top of the compute module.
2. Slide the access panel forward until it clicks into place.

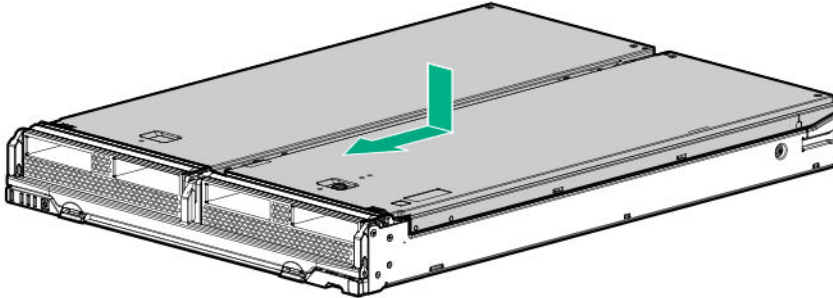

Removing and replacing a drive blank

Procedure

1. Press the drive release button.
2. Remove the drive.

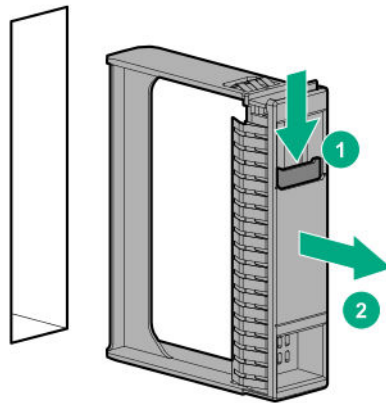

⚠ CAUTION: To prevent improper cooling and thermal damage, do not operate the compute module unless all bays are populated with either a component or a blank.

To replace the component, reverse the removal procedure.

Removing the DIMM baffle

Procedure

1. Power down the compute module.
2. Remove the compute module.

3. Place the compute module on a flat, level work surface.

4. **Remove the access panel.**

❗ **IMPORTANT:** When removing the right DIMM baffle, leave the energy pack option installed on the baffle.

5. Remove one or more DIMM baffles.

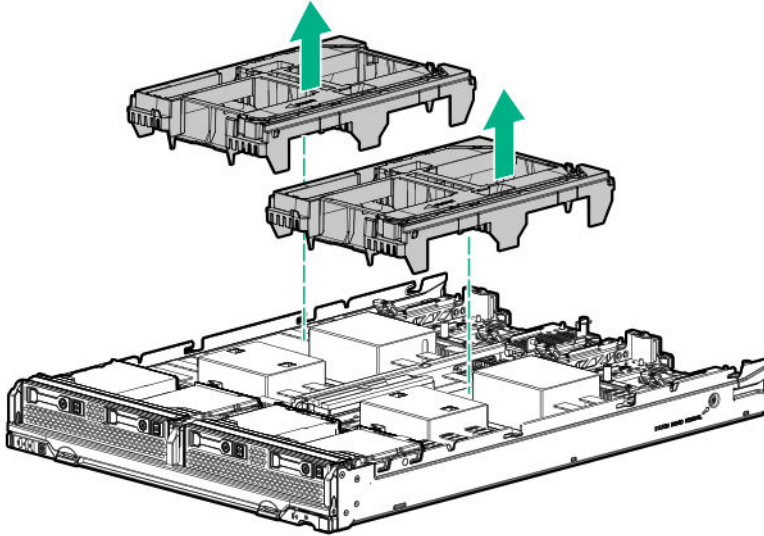

Installing the DIMM baffles

Procedure

1. Install the DIMM baffles.

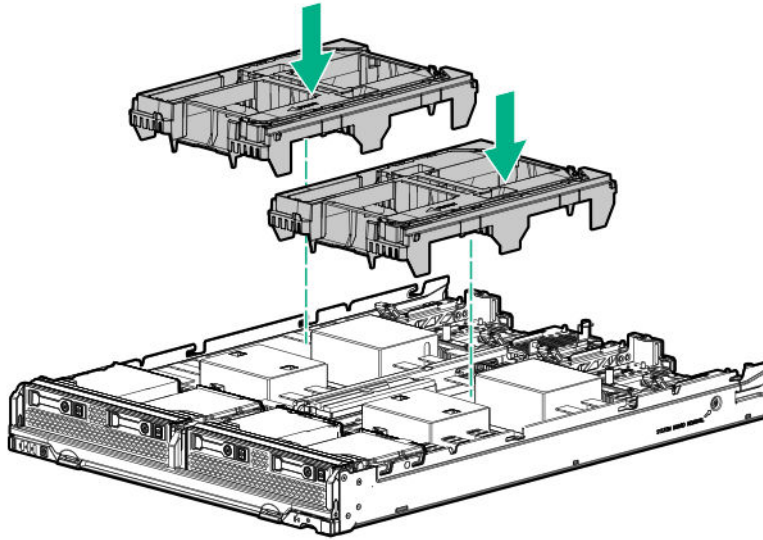

2. Install the access panel.
3. Install the compute module.

Removing the front panel/drive cage assembly

Procedure

1. Power down the compute module.
2. Remove the compute module.
3. Place the compute module on a flat, level work surface.
4. Remove the access panel.
5. Remove all drives.
6. Remove all drive blanks.
7. Remove the front panel/drive cage assembly.

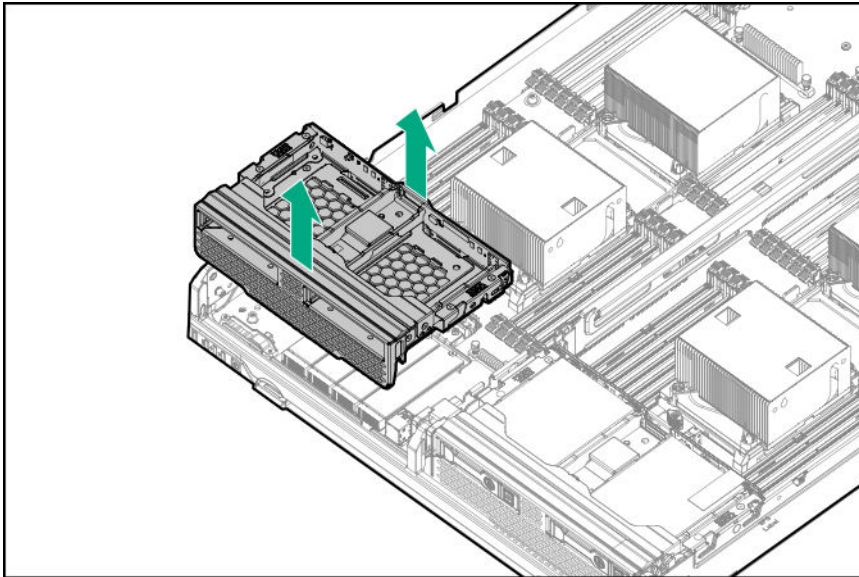

Installing the front panel/drive cage assembly

Procedure

1. Install the front panel/drive cage assembly.

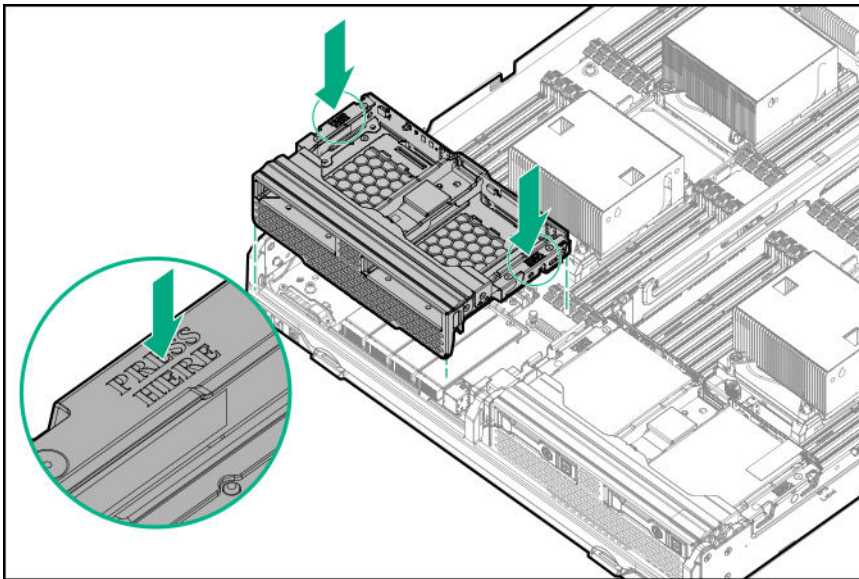

2. Install all drives.
3. Install drive blanks in unpopulated drive bays.
4. Install the access panel.
5. Install the compute module.

Setup

Installation overview

This section provides instructions for installing an HPE Synergy 660 Gen10 Compute Module in a compute module for the first time.

Installation of a compute module requires the following steps:

Procedure

1. Installing supported hardware options for the compute module.
2. Installing the compute module.
3. Completing compute module configuration.

Installing the compute module

Procedure

1. Verify that the device bay is configured for a full-height compute module. For more information, see the setup and installation guide for the compute module on the [Hewlett Packard Enterprise website](#).
2. Remove the compute module end cap.

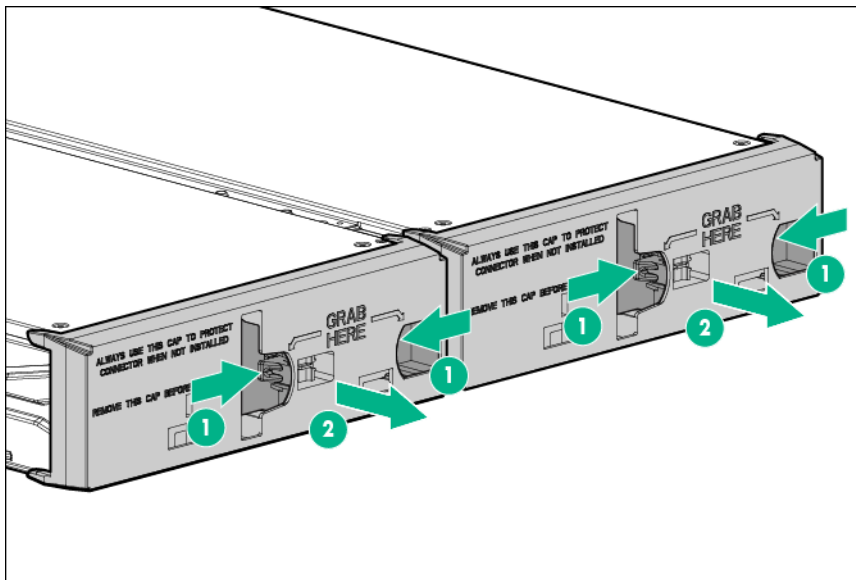

3. Prepare the compute module for installation by opening the compute module handle.

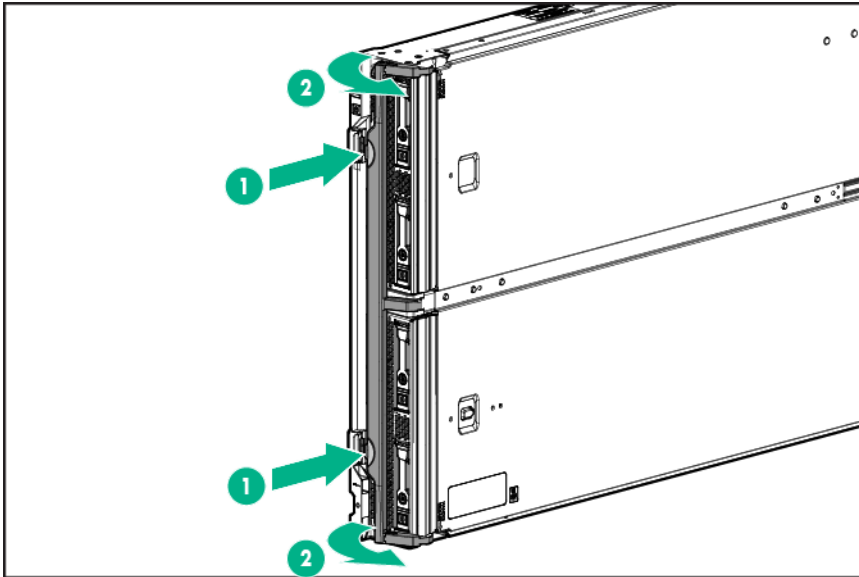

4. Install the compute module. Press the compute module handle near each release button to completely close the handle.

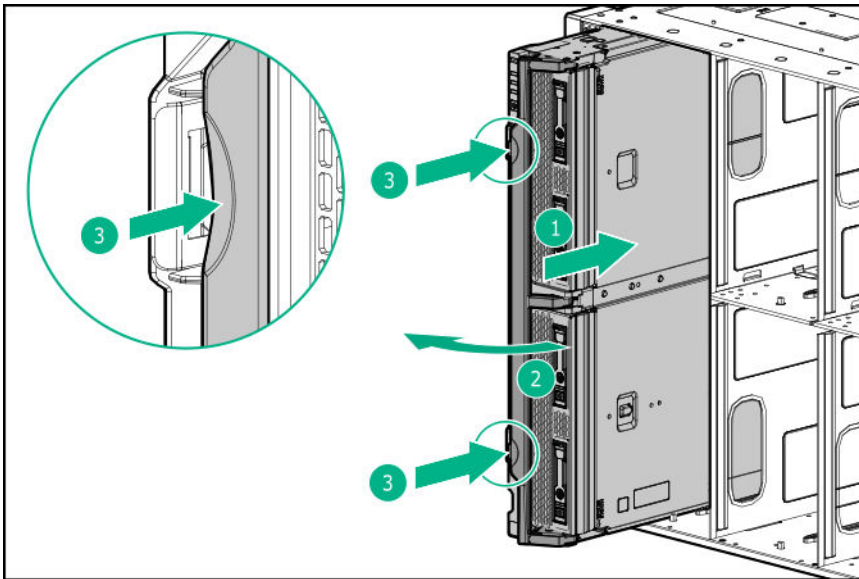

5. Review the compute module front panel LEDs to determine the compute module status. For more information on the compute module LEDs, see "[Component identification](#)."

Installing the compute module options

Before installing and initializing the compute module, install any compute module options, such as an additional processor, drive, or a mezzanine card.

Mezzanine options are classified as Type C and Type D mezzanine cards. The type of mezzanine card determines where the card can be installed in the compute module. Some mezzanine cards require that an interconnect module is installed in the associated ICM bay in the rear of the frame. Be sure to review the mezzanine card mapping information in the *HPE Synergy Configuration and Compatibility Guide* on the Hewlett Packard Enterprise website (<http://www.hpe.com/info/synergy-docs>).

For a list of supported options, see the product QuickSpecs on the Hewlett Packard Enterprise website (<http://www.hpe.com/info/qs>).

For compute module options installation information, see [Hardware options installation](#).

Completing the configuration

When a compute module is added to an existing configuration, HPE OneView automatically detects the new hardware. HPE OneView is hosted on the HPE Synergy Composer appliance installed in the HPE Synergy 12000 Frame. You can use HPE OneView to comprehensively manage an HPE Synergy system throughout the hardware life cycle.

To configure the compute module for the first time, log in to HPE OneView from the frame using your assigned user name and password. For more information, see the *HPE Synergy 12000 Frame Setup and Installation Guide* on the Hewlett Packard Enterprise website (<http://www.hpe.com/info/synergy-docs>). For more information about HPE OneView, see the *HPE OneView User Guide* on the Hewlett Packard Enterprise website (<http://www.hpe.com/info/synergy-docs>).

Hardware options installation

Introduction

If more than one option is being installed, read the installation instructions for all the hardware options and identify similar steps to streamline the installation process.

⚠ WARNING: To reduce the risk of personal injury from hot surfaces, allow the drives and the internal system components to cool before touching them.

⚠ CAUTION: To prevent damage to electrical components, properly ground the compute module before beginning any installation procedure. Improper grounding can cause electrostatic discharge.

Installing the drive option

The compute module supports up to two SFF SAS, NVMe, solid state, or SATA (supported only with the HPE Synergy 660 Gen10 compute module backplane) drives.

⚠ CAUTION: To prevent improper cooling and thermal damage, do not operate the compute module or the frame unless all drive and device bays are populated with either a component or a blank.

Procedure

1. Remove the drive blank.
2. Prepare the drive:
 - SAS, SATA, or solid state

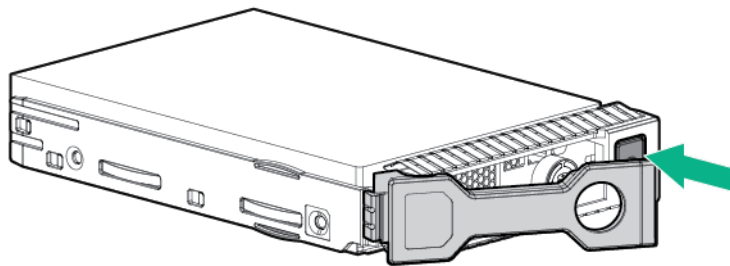

- NVMe—Press **Do Not Remove** to open the release handle.

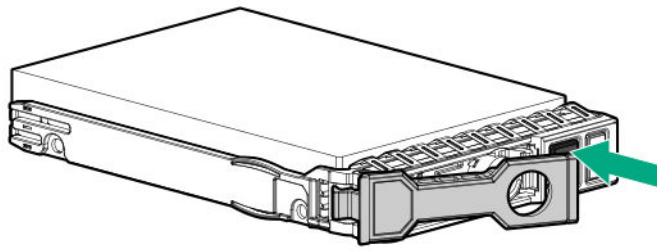

3. Install the drive:

- SAS, SATA, or solid state

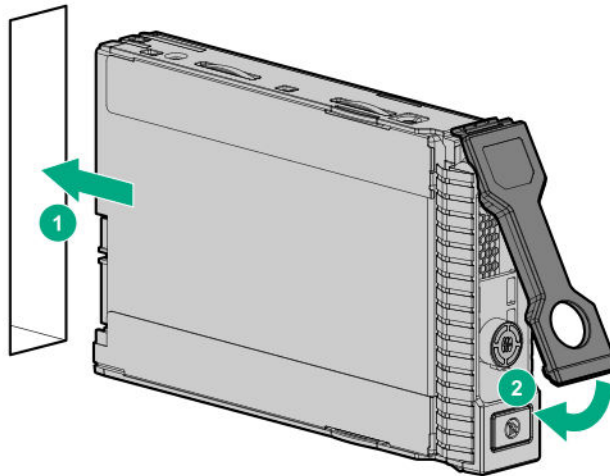

- NVMe

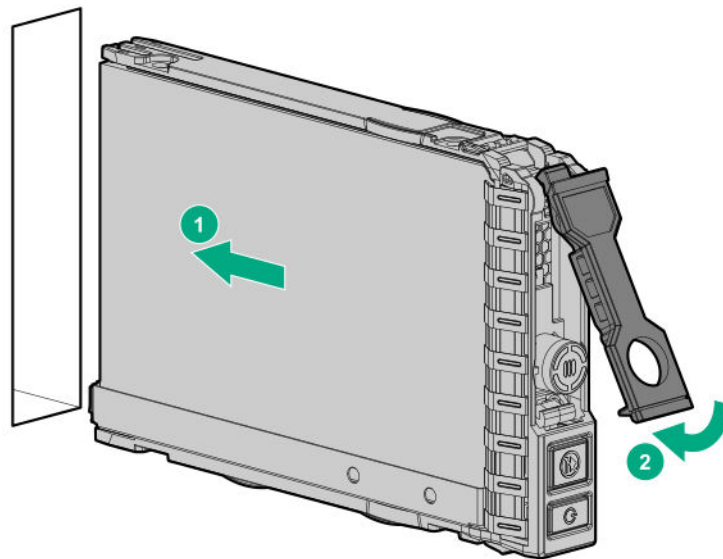

4. Determine the status of the drive from the drive LED definitions.

Installing the SFF flash adapter option

CAUTION: To prevent improper cooling and thermal damage, do not operate the compute module or the enclosure unless all drive and device bays are populated with either a component or a blank.

Prerequisites

The SFF flash adapter option is supported when any of the following components are installed:

- HPE Dynamic Smart Array S100i Controller
- HPE Smart Array E208i-c/P204i-c/P416ie-m Controller
- HPE Synergy 3830C 16G FC HBA
- HPE Synergy 3530C 16G FC HBA

Procedure

1. Remove the drive blank.
2. Install the uFF drives in the SFF flash adapter.

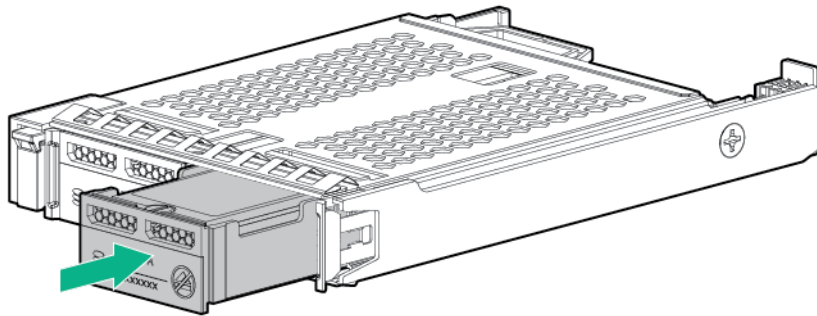

3. Install the SFF flash adapter by pushing firmly near the left-side adapter ejection handle until the latching spring engages in the drive bay.

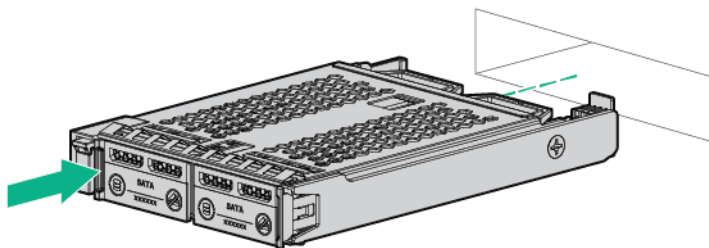

Installing the M.2 SSD flash drive

Procedure

1. **Power down the compute module.**
2. **Remove the compute module.**
3. Lay the compute module on a flat and level surface.
4. **Remove the access panel.**
5. Remove the front panel/drive cage assembly.
6. Locate the SSD slot, and install SSD flash drive to the appropriate slot.

! **IMPORTANT:** You must install the SSD flash drive to the connector at an angle first, and then lower it down onto the mounting standoffs to ensure proper installation.

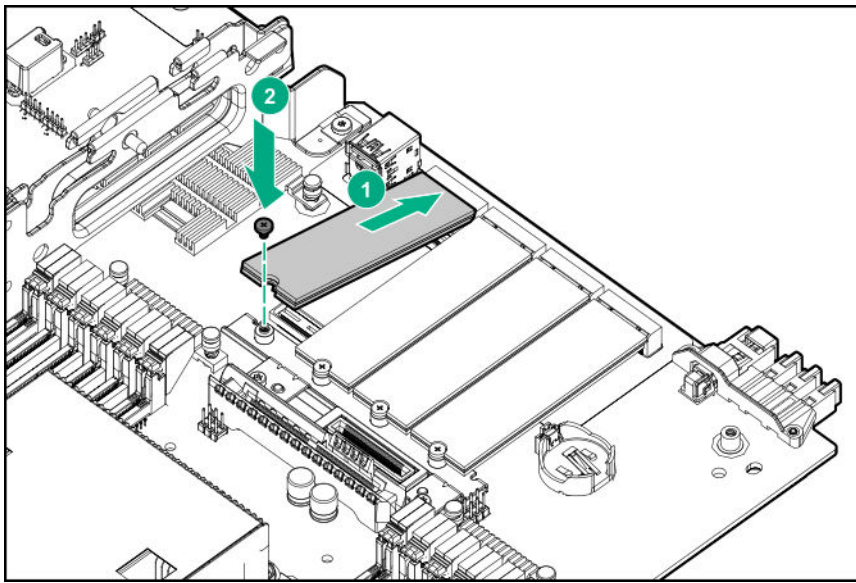

7. Secure the SSD flash drive to the board standoff.
8. Repeat the SSD flash drive installation on the second SSD flash drive, as applicable.

Installing the controller option

For more information about supported options, see the product QuickSpecs on the **Hewlett Packard Enterprise website**.

⚠ CAUTION: Hewlett Packard Enterprise recommends performing a complete backup of all compute module data before performing a controller or adapter installation or removal.

⚠ CAUTION: In systems that use external data storage, be sure that the compute module is the first unit to be powered down and the last to be powered back up. Taking this precaution ensures that the system does not erroneously mark the drives as failed when the compute module is powered up.

To install the component:

Procedure

1. **Power down the compute module.**
2. **Remove the compute module.**
3. **Remove the access panel.**
4. **Remove the front panel/drive cage assembly.**
5. Install the controller.

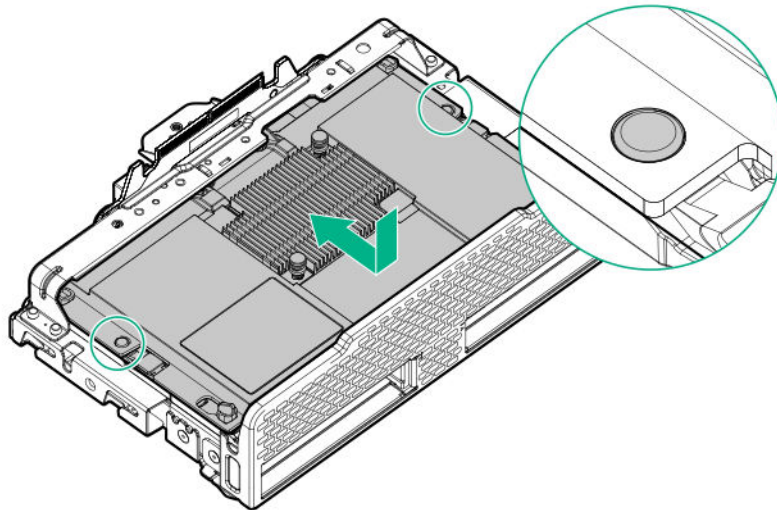

6. **Install the front panel/drive cage assembly.**
7. **Install the access panel.**
8. Install the compute module.
9. **Power up the compute module.**

HPE Smart Storage Battery

The HPE Smart Storage Battery supports the following devices:

- HPE Smart Array SR controllers
- HPE Smart Array MR controllers

A single 96W battery can support up to 24 devices.

After the battery is installed, it might take up to two hours to charge. Controller features requiring backup power are not re-enabled until the battery is capable of supporting the backup power.

This server supports the 96W HPE Smart Storage Battery with the 260mm cable.

HPE Smart Storage Hybrid Capacitor

The HPE Smart Storage Hybrid Capacitor supports the following devices:

- HPE Smart Array SR controllers
- HPE Smart Array MR controllers

The capacitor pack can support up to three devices.

This server supports the HPE Smart Storage Hybrid Capacitor with the 260mm cable.

Before installing the HPE Smart Storage Hybrid Capacitor, verify that the system BIOS meets the minimum firmware requirements to support the capacitor pack.

❗ **IMPORTANT:** If the system BIOS or controller firmware is older than the minimum recommended firmware versions, the capacitor pack will only support one device.

The capacitor pack is fully charged after the system boots.

Minimum firmware versions

Product	Minimum firmware version
HPE Synergy 660 Gen10 Compute Module system ROM	2.00
HPE Smart Array SR controllers	1.90
HPE Smart Array MR controllers	24.23.0-0041

Installing the energy pack option

Hewlett Packard Enterprise now offers two options as a centralized backup power source for backing up write cache content on Smart Array controllers in case of an unplanned server power loss.

- **HPE Smart Storage Battery**
- **HPE Smart Storage Hybrid Capacitor**

❗ **IMPORTANT:** The HPE Smart Storage Hybrid Capacitor is only supported on Gen10 and later servers that support the 96W HPE Smart Storage Battery.

Only one energy pack is required per server, as it can support multiple devices.

To install the component:

Procedure

1. **Power down the compute module.**
2. **Remove the compute module.**
3. Place the compute module on a flat, level work surface.
4. **Remove the access panel.**
5. **Remove the DIMM baffle.**
6. Install the energy pack.

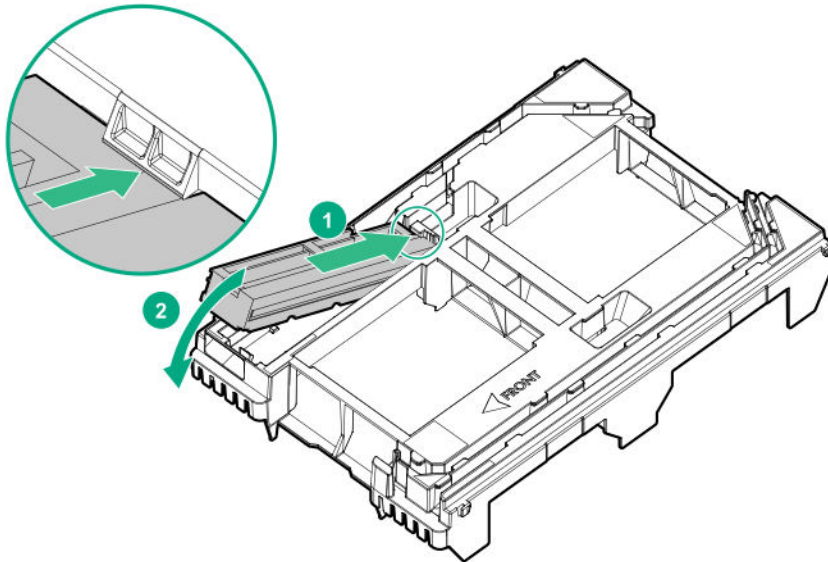

7. Install the DIMM baffle.
8. Connect the energy pack to the system board. To locate the energy pack connector, see "[System board components](#)."

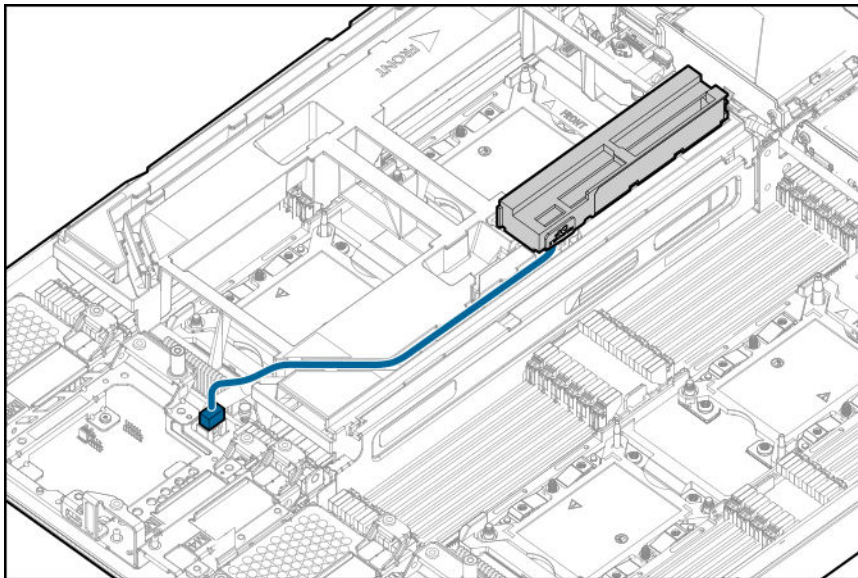

ⓘ **IMPORTANT:** To enable SmartCache or CacheCade in a P-class type-p Smart Array controller, you must:

- Connect the controller backup power cable to the controller backup power connector on the system or riser board.
- Connect the energy pack cable to the connector on the system board.

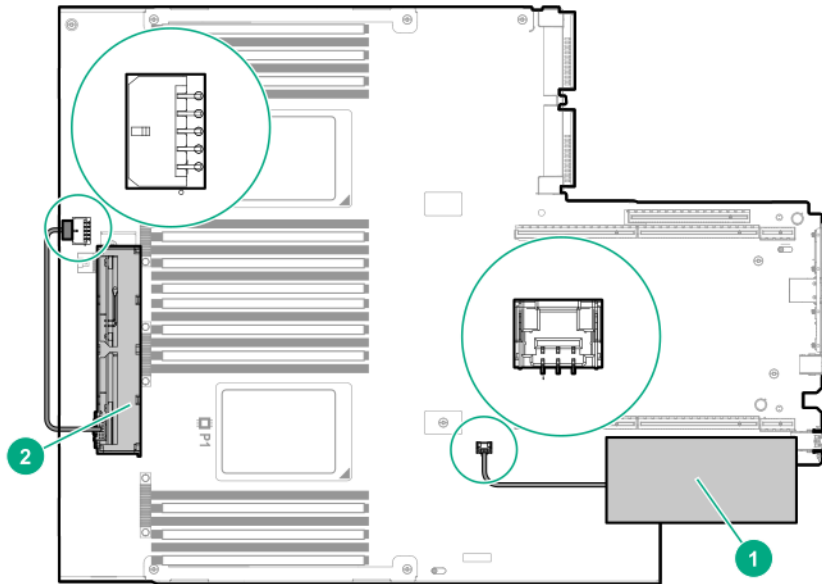

Item	Description ¹
1	Type-p Smart Array controller connected to the controller backup power connector
2	Energy pack connected to the energy pack connector

¹ Your server might appear different.

9. **Install the access panel.**
10. **Install the compute module.**
11. **Power up the compute module.**

Installing the mezzanine card options

- !** **IMPORTANT:** For more information about the association between the mezzanine bay and the interconnect bays, see the *HPE Synergy 12000 Frame Setup and Installation Guide* in the **Hewlett Packard Enterprise Information Library**. Where you install the mezzanine card determines where you need to install the interconnect modules.

To install the component:

Procedure

1. **Power down the compute module.**
2. **Remove the compute module.**
3. Place the compute module on a flat, level work surface.
4. **Remove the access panel.**
5. Locate the appropriate mezzanine connector. To locate the connector, see the "**System board components.**"
6. Remove the mezzanine connector cover, if installed.

7. Install the mezzanine card. Press firmly on the **PRESS HERE** label above the mezzanine connector to seat the card.
8. If you are installing an HPE Smart Array Controller with an NVMe-enabled backplane and SAS hard drives, you must connect a cable between the mezzanine card and the NVMe-enabled backplane.

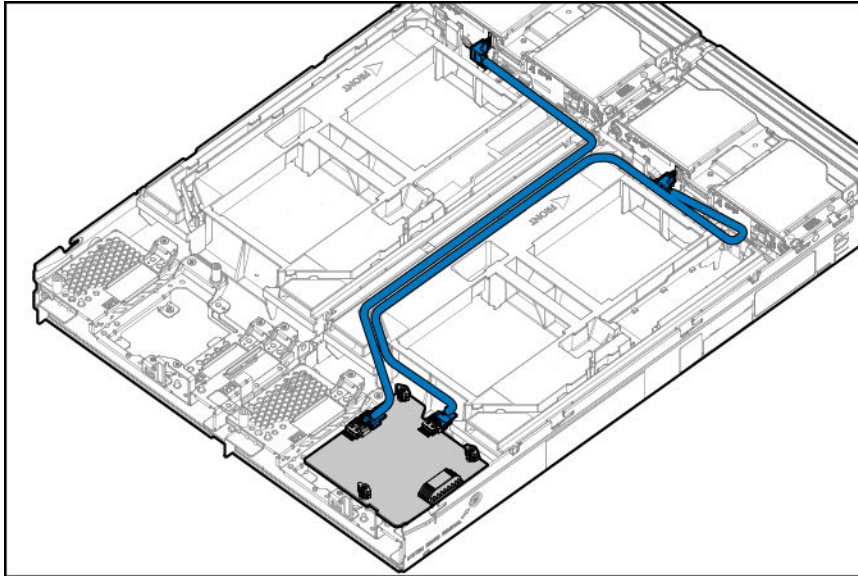

9. **Install the access panel.**
10. **Install the compute module.**
11. **Power up the compute module.**

Memory options

- ⓘ **IMPORTANT:** This compute module does not support mixing LRDIMMs and RDIMMs. Attempting to mix any combination of these DIMMs can cause the server to halt during BIOS initialization. All memory installed in the compute module must be of the same type.

DIMM and NVDIMM population information

For specific DIMM and NVDIMM population information, see the DIMM population guidelines on the Hewlett Packard Enterprise website (<http://www.hpe.com/docs/memory-population-rules>).

DIMM-processor compatibility

The installed processor determines the type of DIMM that is supported in the compute module:

- First-generation Intel Xeon Scalable processors support DDR4-2666 DIMMs.
- Second-generation Intel Xeon Scalable processors support DDR4-2933 DIMMs.

Mixing DIMM types is not supported. Install only the supported DDR4-2666 or DDR4-2933 DIMMs in the compute module.

HPE SmartMemory speed information

For more information about memory speed information, see the Hewlett Packard Enterprise website (<https://www.hpe.com/docs/memory-speed-table>).

Installing a DIMM

The server supports up to 24 DIMMs.

Prerequisites

Before installing this option, be sure you have the following:

The components included with the hardware option kit

For more information on specific options, see the compute module QuickSpecs on the [Hewlett Packard Enterprise website](#).

Procedure

1. **Power down the compute module.**
2. **Remove the compute module.**
3. Place the compute module on a flat, level work surface.
4. **Remove the access panel.**
5. Open the DIMM slot latches.
6. Install the DIMM .

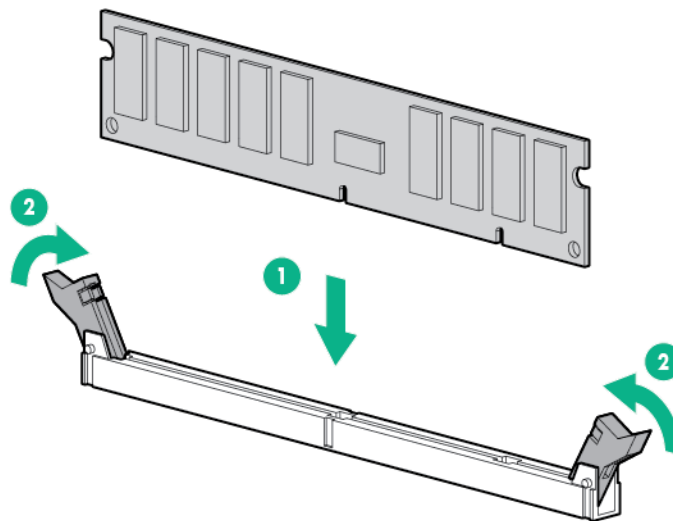

7. **Install the access panel.**
8. Install the compute module in the rack.
9. **Install the compute module.**
10. **Power up the compute module.**

Use the BIOS/Platform Configuration (RBSU) in the UEFI System Utilities to configure the memory mode.

HPE 16GB NVDIMM option

HPE NVDIMMs are flash-backed NVDIMMs used as fast storage and are designed to eliminate smaller storage bottlenecks. The HPE 16GB NVDIMM for HPE ProLiant Gen10 servers is ideal for smaller database storage bottlenecks, write caching tiers, and any workload constrained by storage bottlenecks.

The HPE 16GB NVDIMM is supported on select HPE ProLiant Gen10 servers with first generation Intel Xeon Scalable processors. The compute module can support up to 12 NVDIMMs in 2 socket servers (up to 192GB) and up to 24 NVDIMMs in 4 socket servers (up to 384GB). The HPE Smart Storage Battery provides backup power to the memory slots allowing data to be moved from the DRAM portion of the NVDIMM to the Flash portion for persistence during a power down event.

For more information on HPE NVDIMMs, see the Hewlett Packard Enterprise website (<http://www.hpe.com/info/persistentmemory>).

NVDIMM-processor compatibility

HPE 16GB NVDIMMs are only supported in servers with first generation Intel Xeon Scalable processors installed.

Server requirements for NVDIMM support

Before installing an HPE 16GB NVDIMM in a compute module, make sure that the following components and software are available:

- A supported HPE server using Intel Xeon Scalable Processors: For more information, see the NVDIMM QuickSpecs on the Hewlett Packard Enterprise website (<http://www.hpe.com/info/qs>).
- An HPE Smart Storage Battery
- A minimum of one regular DIMM: The system cannot have only NVDIMM-Ns installed.
- A supported operating system with persistent memory/NVDIMM drivers. For the latest software information, see the Hewlett Packard Enterprise website (<http://persistentmemory.hpe.com>).
- For minimum firmware versions, see the HPE 16GB NVDIMM User Guide on the Hewlett Packard Enterprise website (<http://www.hpe.com/info/nvdimm-docs>).

To determine NVDIMM support for your compute module, see the compute module QuickSpecs on the Hewlett Packard Enterprise website (<http://www.hpe.com/info/qs>).

Installing an NVDIMM

-
- △ **CAUTION:** To avoid damage to the hard drives, memory, and other system components, the air baffle, drive blanks, and access panel must be installed when the server is powered up.
-
- △ **CAUTION:** To avoid damage to the hard drives, memory, and other system components, be sure to install the correct DIMM baffles for your server model.
-
- △ **CAUTION:** DIMMs are keyed for proper alignment. Align notches in the DIMM with the corresponding notches in the DIMM slot before inserting the DIMM. Do not force the DIMM into the slot. When installed properly, not all DIMMs will face in the same direction.
-
- △ **CAUTION:** Electrostatic discharge can damage electronic components. Be sure you are properly grounded before beginning this procedure.
-

-
- ⚠ CAUTION:** Failure to properly handle DIMMs can damage the DIMM components and the system board connector. For more information, see the DIMM handling guidelines in the troubleshooting guide for your product on the Hewlett Packard Enterprise website:
- HPE ProLiant Gen10 (<http://www.hpe.com/info/gen10-troubleshooting>)
 - HPE Synergy (<http://www.hpe.com/info/synergy-troubleshooting>)
-

- ⚠ CAUTION:** Unlike traditional storage devices, NVDIMMs are fully integrated in with the ProLiant compute module. Data loss can occur when system components, such as the processor or HPE Smart Storage Battery, fails. HPE Smart Storage battery is a critical component required to perform the backup functionality of NVDIMMs. It is important to act when HPE Smart Storage Battery related failures occur. Always follow best practices for ensuring data protection.
-

Prerequisites

Before installing an NVDIMM, be sure the compute module meets the **Server requirements for NVDIMM support** on page 42.

Procedure

1. **Power down the compute module.**
2. **Remove the compute module.**
3. Place the compute module on a flat, level work surface.
4. **Remove the access panel.**
5. Locate any NVDIMMs already installed in the compute module.
6. Verify that all LEDs on any installed NVDIMMs are off.
7. Install the NVDIMM.

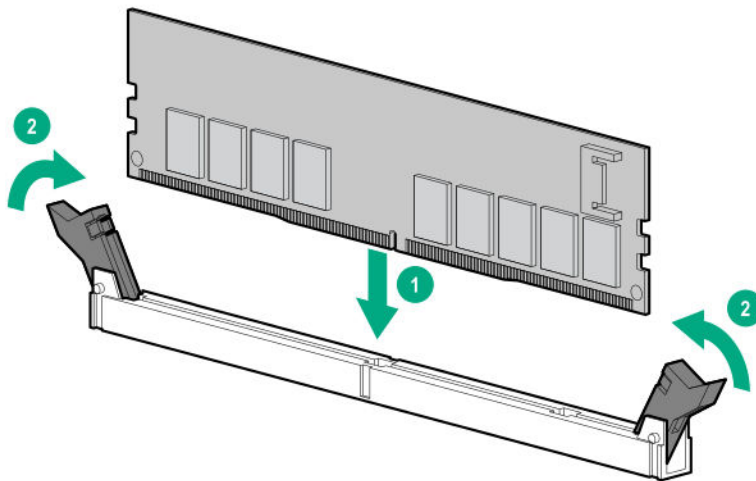

8. **Install and connect the energy pack option,** if it is not already installed.
9. Install any components removed to access the DIMM slots and the energy pack option.
10. **Install the access panel.**
11. **Install the compute module.**

12. Power up the compute module.

13. If required, sanitize the NVDIMM-Ns. For more information, see **NVDIMM sanitization** on page 44.

Configuring the compute module for NVDIMMs

After installing NVDIMMs, configure the compute module for NVDIMMs. For information on configuring settings for NVDIMMs, see the *HPE 16GB NVDIMM User Guide* on the Hewlett Packard Enterprise website (<http://www.hpe.com/info/nvdimm-docs>).

The compute module can be configured for NVDIMMs using either of the following:

- UEFI System Utilities—Use System Utilities through the Remote Console to configure the compute module for NVDIMM memory options by pressing the **F9** key during POST. For more information about UEFI System Utilities, see the Hewlett Packard Enterprise website (<http://www.hpe.com/info/uefi/docs>).
- iLO RESTful API for HPE iLO 5—For more information about configuring the system for NVDIMMs, see <https://hewlettpackard.github.io/ilo-rest-api-docs/ilo5/>.

NVDIMM sanitization

Media sanitization is defined by NIST SP800-88 Guidelines for Media Sanitization (Rev 1, Dec 2014) as "a general term referring to the actions taken to render data written on media unrecoverable by both ordinary and extraordinary means."

The specification defines the following levels:

- Clear: Overwrite user-addressable storage space using standard write commands; might not sanitize data in areas not currently user-addressable (such as bad blocks and overprovisioned areas)
- Purge: Overwrite or erase all storage space that might have been used to store data using dedicated device sanitize commands, such that data retrieval is "infeasible using state-of-the-art laboratory techniques"
- Destroy: Ensure that data retrieval is "infeasible using state-of-the-art laboratory techniques" and render the media unable to store data (such as disintegrate, pulverize, melt, incinerate, or shred)

The NVDIMM-N Sanitize options are intended to meet the Purge level.

For more information on sanitization for NVDIMMs, see the following sections in the *HPE 16GB NVDIMM User Guide* on the Hewlett Packard Enterprise website (<http://www.hpe.com/info/nvdimm-docs>):

- NVDIMM sanitization policies
- NVDIMM sanitization guidelines
- Setting the NVDIMM-N Sanitize/Erase on the Next Reboot Policy

NIST SP800-88 *Guidelines for Media Sanitization* (Rev 1, Dec 2014) is available for download from the NIST website (<http://nvlpubs.nist.gov/nistpubs/SpecialPublications/NIST.SP.800-88r1.pdf>).

NVDIMM relocation guidelines

Requirements for relocating NVDIMMs or a set of NVDIMMs when the data must be preserved

- The destination compute module hardware must match the original compute module hardware configuration.
- All System Utilities settings in the destination compute module must match the original System Utilities settings in the original compute module.
- If NVDIMM-Ns are used with NVDIMM Interleaving ON mode in the original compute module, do the following:
 - Install the NVDIMMs in the same DIMM slots in the destination compute module.
 - Install the entire NVDIMM set (all the NVDIMM-Ns on the processor) on the destination compute module.

This guideline would apply when replacing a system board due to system failure.

If any of the requirements cannot be met during NVDIMM relocation, do the following:

- Manually back up the NVDIMM-N data before relocating NVDIMM-Ns to another compute module.
- Relocate the NVDIMM-Ns to another compute module.
- Sanitize all NVDIMM-Ns on the new compute module before using them.

Requirements for relocating NVDIMMs or a set of NVDIMMs when the data does not have to be preserved

If data on the NVDIMM-N or set of NVDIMM-Ns does not have to be preserved, then

- Move the NVDIMM-Ns to the new location and sanitize all NVDIMM-Ns after installing them to the new location. For more information, see [NVDIMM sanitization](#) on page 44.
- Observe all DIMM and NVDIMM population guidelines. For more information, see [DIMM and NVDIMM population information](#) on page 40.
- Observe the process for removing an NVDIMM.
- Observe the process for installing an NVDIMM.
- Review and configure the system settings for NVDIMMs. For more information, see [Configuring the compute module for NVDIMMs](#) on page 44.

HPE Persistent Memory option

HPE Persistent Memory, which offers the flexibility to deploy as dense memory or fast storage and features Intel Optane DC Persistent Memory, enables per-socket memory capacity of up to 3.0 TB. HPE Persistent Memory, together with traditional volatile DRAM DIMMs, provide fast, high-capacity, cost-effective memory and storage to transform big data workloads and analytics by enabling data to be stored, moved, and processed quickly.

HPE Persistent Memory modules use the standard DIMM form factor and are installed alongside DIMMs in a compute module memory slot. HPE Persistent Memory modules are designed for use only with second-generation Intel Xeon Scalable processors, and are available in the following capacities:

- 128 GB
- 256 GB
- 512 GB

HPE Persistent Memory module-processor compatibility

HPE Persistent Memory modules are supported only in compute modules with second-generation Intel Xeon Scalable processors installed.

HPE Persistent Memory population information

For specific population and configuration information, see the memory population guidelines on the Hewlett Packard Enterprise website (<http://www.hpe.com/docs/memory-population-rules>).

System requirements for HPE Persistent Memory module support

! **IMPORTANT:** Hewlett Packard Enterprise recommends that you implement best practice configurations for high availability (HA) such as clustered configurations.

Before installing HPE Persistent Memory modules, make sure that the following components and software are available:

- A supported HPE ProLiant Gen10 server or Synergy compute module using second-generation Intel Xeon Scalable processors. For more information, see the product QuickSpecs on the Hewlett Packard Enterprise website (<http://www.hpe.com/support/persistentmemoryQS>).
- HPE DDR4 Standard Memory RDIMMs or LRDIMMs (the number will vary based on your chosen configuration).
- Supported firmware and drives:
 - System ROM version 2.10 or later
 - Server Platform Services (SPS) Firmware version 04.01.04.296
 - HPE iLO 5 Firmware version 1.43
 - HPE Innovation Engine Firmware version 2.1.x or later

Download the required firmware and drivers from the Hewlett Packard Enterprise website (<http://www.hpe.com/info/persistentmemory>).
- A supported operating system:
 - Windows Server 2012 R2 with persistent memory drivers from Hewlett Packard Enterprise
 - Windows Server 2016 with persistent memory drivers from Hewlett Packard Enterprise
 - Windows Server 2019
 - Red Hat Enterprise Linux 7.6
 - Red Hat Enterprise Linux 8.0
 - SUSE Linux Enterprise Server 12 SP4
 - SUSE Linux Enterprise Server 15 with SUSE-SU-2019:0224-1 kernel update

- SUSE Linux Enterprise Server 15 SP1
- VMware vSphere 6.7 U1
- Hardware and licensing requirements for optional encryption of the HPE Persistent Memory modules:
 - HPE TPM 2.0 (local key encryption)
 - HPE iLO Advanced Pack license (remote key encryption)
 - Key management server (remote key encryption)

For more information, see the *HPE Persistent Memory User Guide* on the Hewlett Packard Enterprise website (<http://www.hpe.com/info/persistentmemory-docs>).

Installing HPE Persistent Memory modules

-  **IMPORTANT:** Hewlett Packard Enterprise recommends that you implement best practice configurations for high availability (HA) such as clustered configurations.

Prerequisites

Before you perform this procedure, make sure that you have the following items available:

- The components included with the hardware option kit
- A T-10 Torx screwdriver might be needed to unlock the access panel.

Procedure

1. Observe the following alerts:

 **CAUTION:** DIMMs are keyed for proper alignment. Align notches in the DIMM with the corresponding notches in the DIMM slot before inserting the DIMM. Do not force the DIMM into the slot. When installed properly, not all DIMMs will face in the same direction.

 **CAUTION:** Electrostatic discharge can damage electronic components. Be sure you are properly grounded before beginning this procedure.

 **CAUTION:** Failure to properly handle DIMMs can damage the DIMM components and the system board connector. For more information, see the DIMM handling guidelines in the troubleshooting guide for your product on the Hewlett Packard Enterprise website:

- HPE ProLiant Gen10 (<http://www.hpe.com/info/gen10-troubleshooting>)
- HPE Synergy (<http://www.hpe.com/info/synergy-troubleshooting>)

2. **Power down the compute module.**

- a. Shut down the OS as directed by the OS documentation.
- b. To place the compute module in standby mode, press the Power On/Standby button. When the compute module enters standby power mode, the system power LED changes to amber.
- c. Disconnect the power cords (rack and tower servers).

3. **Remove the compute module.**

4. Place the compute module on a flat, level work surface.
5. **Remove the access panel.**
6. Remove all components necessary to access the DIMM slots.
7. Install the HPE Persistent Memory module.

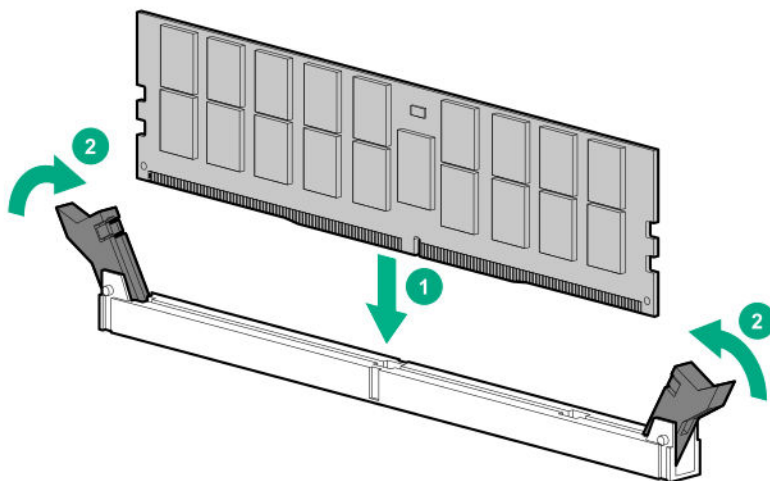

8. Install any components removed to access the DIMM slots.
9. **Install the access panel.**
10. Slide or install the compute module into the frame.
11. If removed, reconnect all power cables.
12. **Power up the compute module.**
13. **Configure the server for HPE Persistent Memory.**

More information

[HPE Persistent Memory population information](#) on page 46

[Configuring the compute module for HPE Persistent Memory](#) on page 48

Configuring the compute module for HPE Persistent Memory

After installing HPE Persistent Memory modules, configure the compute module for HPE Persistent Memory.

! **IMPORTANT:** Always follow recommendations from your software application provider for high-availability best practices to ensure maximum uptime and data protection.

A number of configuration tools are available, including:

- UEFI System Utilities—Access System Utilities through the Remote Console to configure the compute module by pressing the **F9** key during POST.
- iLO RESTful API—Use the iLO RESTful API through tools such as the RESTful Interface Tool (ilorest) or other third-party tools.
- HPE Persistent Memory Management Utility—The HPE Persistent Memory Management Utility is a desktop application used to configure the compute module for HPE Persistent Memory, as well as evaluate and monitor the compute module memory configuration layout.

For more information, see the *HPE Persistent Memory User Guide* on the Hewlett Packard Enterprise website (<http://www.hpe.com/info/persistentmemory-docs>).

HPE Persistent Memory module relocation guidelines

Observe the relocation guidelines when doing the following:

- When relocating HPE Persistent Memory modules to another DIMM slot on the compute module.
- When relocating HPE Persistent Memory modules to another compute module.
- When reinstalling HPE Persistent Memory modules after replacing the compute module system board.

! **IMPORTANT:** When data must be preserved, Hewlett Packard Enterprise strongly recommends that you perform a manual backup of all user data on the HPE Persistent Memory modules before performing relocation procedures.

Requirements for relocating HPE Persistent Memory modules or a set of HPE Persistent Memory modules when the data must be preserved

- The destination compute module hardware must match the original compute module hardware configuration.
- All System Utilities settings in the destination compute module must match the original System Utilities settings in the original compute module.
- If HPE Persistent Memory modules are used with **Persistent Memory Interleaving** set to Enabled in the original compute module, do the following:
 - Install the HPE Persistent Memory modules in the same DIMM slots in the destination compute module.
 - Install the entire interleaved set (all the DIMMs and HPE Persistent Memory modules on the processor) on the destination compute module.

If any of the requirements cannot be met during relocation, do the following:

- Manually back up the persistent memory data before relocating HPE Persistent Memory modules to another compute module.
- Relocate the HPE Persistent Memory modules to another compute module.
- Sanitize all HPE Persistent Memory modules on the new compute module before using them.

Requirements for relocating encrypted HPE Persistent Memory modules or a set of HPE Persistent Memory modules when the data must be preserved

- If HPE Persistent Memory modules are encrypted with local key management, either manually retrieve the HPE Persistent Memory module passwords from the compute module (user-generated passwords only) or export a password file to a USB key.

Hewlett Packard Enterprise recommends exporting the password file to a USB key.

- Follow the requirements for relocating HPE Persistent Memory modules or a set of HPE Persistent Memory modules when the data must be preserved.
- Do one of the following:

- If HPE Persistent Memory modules are encrypted with local key management, either manually enter the HPE Persistent Memory module passwords in the System Utilities or import the password file from the USB key.
- If HPE Persistent Memory modules are encrypted with remote key management, enroll the HPE iLO in the key management server to provide access to the data on the HPE Persistent Memory modules.

For more information, see the *HPE Persistent Memory User Guide* on the Hewlett Packard Enterprise website (<http://www.hpe.com/info/persistentmemory-docs>).

Requirements for relocating HPE Persistent Memory modules or a set of HPE Persistent Memory modules when the data does not have to be preserved

- Move the HPE Persistent Memory modules to the new location and sanitize all HPE Persistent Memory modules after installing them to the new location.
- Observe the DIMM and HPE Persistent Memory module population guidelines.
- Observe the process for removing an HPE Persistent Memory module.
- Observe the process for installing an HPE Persistent Memory module.
- Review and configure the system settings for HPE Persistent Memory.

For more information, see the *HPE Persistent Memory User Guide* on the Hewlett Packard Enterprise website (<http://www.hpe.com/info/persistentmemory-docs>).

Migrating an HPE Persistent Memory module

Installing the processor heatsink option

The server supports installation of 1–4 processors.

-
-  **IMPORTANT:** Existing HPE ProLiant and HPE Synergy Gen10 server products containing first-generation Intel Xeon Scalable processors may not be upgraded to second-generation Intel Xeon Scalable processors at this time. For more information, see the product QuickSpecs on the Hewlett Packard Enterprise website (<http://www.hpe.com/info/qs>).
-

Prerequisites

To complete this procedure, you need a T-30 Torx screwdriver.

Procedure

1. Observe the following cautions and warnings:

 **WARNING:** To reduce the risk of personal injury from hot surfaces, allow the drives and the internal system components to cool before touching them.

 **CAUTION:** To prevent possible compute module malfunction and damage to the equipment, multiprocessor configurations must contain processors with the same part number.

 **CAUTION:** The heatsink thermal interface media is not reusable and must be replaced if the heatsink is removed from the processor after it has been installed.

⚠ CAUTION: To prevent possible compute module overheating, always populate processor socket 2 with a processor and a heatsink or a processor socket cover and a heatsink blank.

⚠ CAUTION: To prevent damage to electrical components, properly ground the compute module before beginning any installation procedure. Improper grounding can cause ESD.

ⓘ IMPORTANT: Processor socket 1 must be populated at all times or the compute module does not function.

2. Update the system ROM.

Locate and download the latest ROM version from the Hewlett Packard Enterprise website (<http://www.hpe.com/support>). Follow the instructions on the website to update the system ROM.

3. **Power down the compute module.**
4. **Remove the compute module.**
5. **Remove the access panel.**
6. **Remove all DIMM baffles.**
7. Remove the heatsink blank. Retain the heatsink blank for future use.

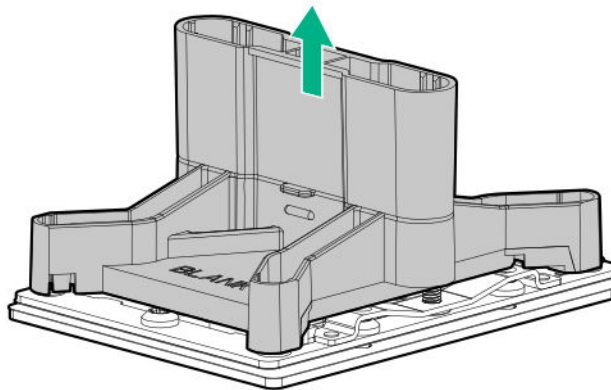

8. Align the processor heatsink assembly with the alignment pins and gently lower it down until it sits evenly on the socket.

The heatsink alignment pins are keyed. The processor will only install one way.

A standard heatsink is shown. Your heatsink might look different.

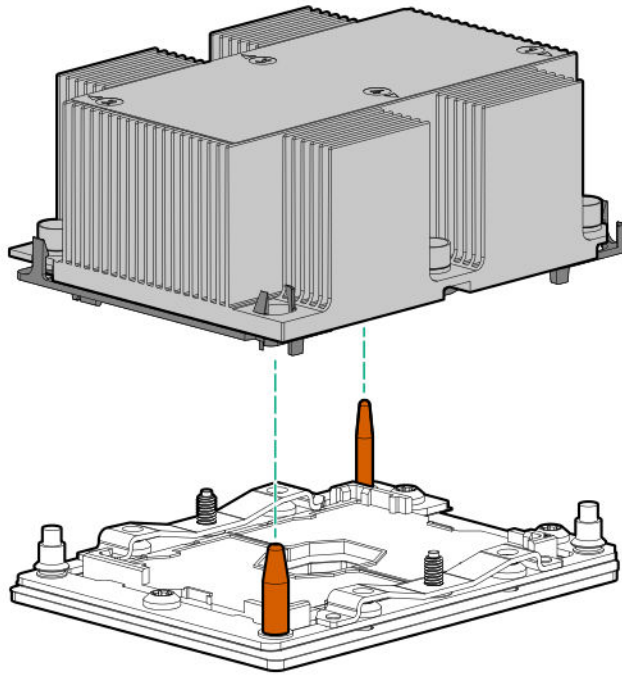

9. Secure the heatsink using a T-30 screwdriver.

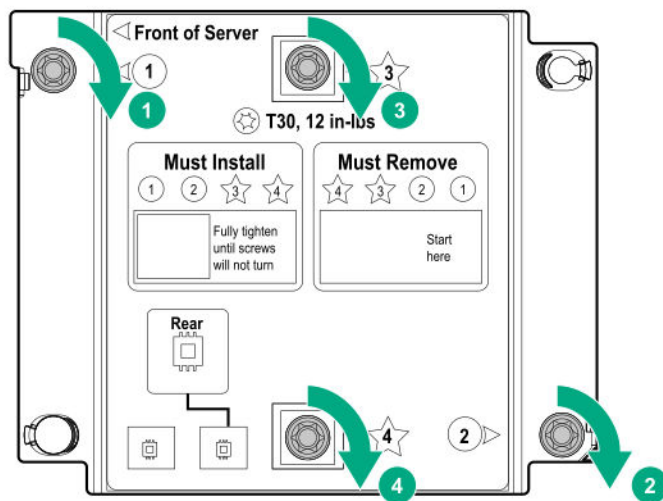

10. Install all DIMM baffles.
11. Install the access panel.
12. Installing supported hardware options for the compute module.

HPE Trusted Platform Module 2.0 Gen10 option

Overview

Use these instructions to install and enable an HPE TPM 2.0 Gen10 Kit in a supported compute module. This option is not supported on Gen9 and earlier compute modules.

This procedure includes three sections:

1. Installing the Trusted Platform Module board.
2. Enabling the Trusted Platform Module.
3. Retaining the recovery key/password.

HPE TPM 2.0 installation is supported with specific operating system support such as Microsoft® Windows Server® 2012 R2 and later. For more information about operating system support, see the product QuickSpecs on the Hewlett Packard Enterprise website (<http://www.hpe.com/info/qs>). For more information about Microsoft® Windows® BitLocker Drive Encryption feature, see the Microsoft website (<http://www.microsoft.com>).

⚠ CAUTION: If the TPM is removed from the original compute module and powered up on a different compute module, data stored in the TPM including keys will be erased.

ⓘ IMPORTANT: In UEFI Boot Mode, the HPE TPM 2.0 Gen10 Kit can be configured to operate as TPM 2.0 (default) or TPM 1.2 on a supported compute module. In Legacy Boot Mode, the configuration can be changed between TPM 1.2 and TPM 2.0, but only TPM 1.2 operation is supported.

HPE Trusted Platform Module 2.0 Guidelines

⚠ CAUTION: Always observe the guidelines in this document. Failure to follow these guidelines can cause hardware damage or halt data access.

Hewlett Packard Enterprise SPECIAL REMINDER: Before enabling TPM functionality on this system, you must ensure that your intended use of TPM complies with relevant local laws, regulations and policies, and approvals or licenses must be obtained if applicable.

For any compliance issues arising from your operation/usage of TPM which violates the above mentioned requirement, you shall bear all the liabilities wholly and solely. Hewlett Packard Enterprise will not be responsible for any related liabilities.

慧与特别提醒：在您启用系统中的TPM功能前，请务必确认您对TPM的使用遵守当地相关法律、法规及政策，并已事先获得所需的一切批准及许可（如适用），因您未获得相应的操作/使用许可而导致的违规问题，皆由您自行承担全部责任，与慧与无涉。

When installing or replacing a TPM, observe the following guidelines:

- Do not remove an installed TPM. Once installed, the TPM becomes a permanent part of the system board.
- When installing or replacing hardware, Hewlett Packard Enterprise service providers cannot enable the TPM or the encryption technology. For security reasons, only the customer can enable these features.
- When returning a system board for service replacement, do not remove the TPM from the system board. When requested, Hewlett Packard Enterprise Service provides a TPM with the spare system board.
- Any attempt to remove the cover of an installed TPM from the system board can damage the TPM cover, the TPM, and the system board.
- If the TPM is removed from the original server and powered up on a different server, data stored in the TPM including keys will be erased.

- When using BitLocker, always retain the recovery key/password. The recovery key/password is required to complete Recovery Mode after BitLocker detects a possible compromise of system integrity.
- Hewlett Packard Enterprise is not liable for blocked data access caused by improper TPM use. For operating instructions, see the TPM documentation or the encryption technology feature documentation provided by the operating system.

Installing and enabling the HPE TPM 2.0 Gen10 Kit

Installing the Trusted Platform Module board

Preparing the compute module for installation

Procedure

1. Observe the following warnings:



WARNING: The front panel Power On/Standby button does not shut off system power. Portions of the power supply and some internal circuitry remain active until AC power is removed.

To reduce the risk of personal injury, electric shock, or damage to the equipment, remove power from the compute module:

For rack and tower servers, remove the power cord.

For server blades and compute modules, remove the server blade or compute module from the enclosure.



WARNING: To reduce the risk of personal injury from hot surfaces, allow the drives and the internal system components to cool before touching them.

2. Update the system ROM.

Locate and download the latest ROM version from the **Hewlett Packard Enterprise Support Center website**. Follow the instructions on the website to update the system ROM.

3. Update the system ROM.

Locate and download the latest ROM version from the Hewlett Packard Enterprise Support Center website (**<http://www.hpe.com/support/hpesc>**). To update the system ROM, follow the instructions on the website.

4. Power down the compute module.

- a. Shut down the OS as directed by the OS documentation.
- b. To place the compute module in standby mode, press the Power On/Standby button. When the compute module enters standby power mode, the system power LED changes to amber.
- c. Disconnect the power cords (rack and tower servers).

5. Do one of the following:

- Remove the compute module from the rack, if necessary.
 - Remove the compute module or compute module blade from the compute module.
6. Place the compute module on a flat, level work surface.
 7. Remove the access panel.
 8. Remove any options or cables that may prevent access to the TPM connector.
 9. Proceed to **Installing the TPM board and cover** on page 55.

Installing the TPM board and cover

Procedure

1. Observe the following alerts:

⚠ CAUTION: If the TPM is removed from the original compute module and powered up on a different compute module, data stored in the TPM including keys will be erased.

⚠ CAUTION: The TPM is keyed to install only in the orientation shown. Any attempt to install the TPM in a different orientation might result in damage to the TPM or system board.

2. Align the TPM board with the key on the connector, and then install the TPM board. To seat the board, press the TPM board firmly into the connector. To locate the TPM connector on the system board, see the compute module label on the access panel.

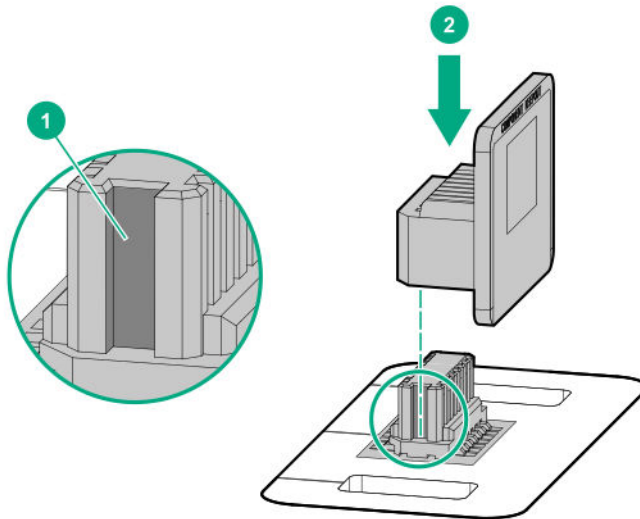

3. Install the TPM cover:
 - a. Line up the tabs on the cover with the openings on either side of the TPM connector.
 - b. To snap the cover into place, firmly press straight down on the middle of the cover.

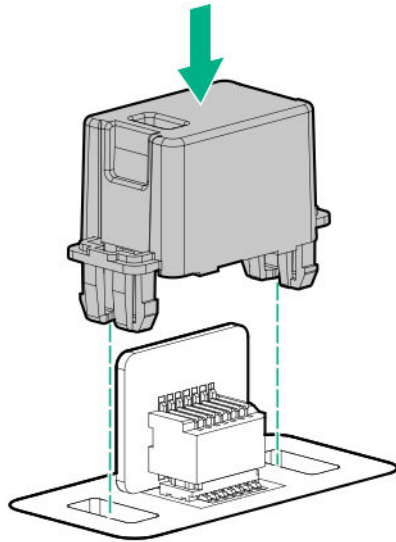

4. Proceed to **Preparing the compute module for operation** on page 56.

Preparing the compute module for operation

Procedure

1. Install any options or cables previously removed to access the TPM connector.
2. Install the access panel.
3. Do one of the following:
 - a. Install the compute module in the rack, if necessary.
 - b. Install the compute module in the enclosure.
4. Power up the compute module.
 - a. Connect the power cords (rack and tower compute modules).
 - b. Press the Power On/Standby button.

Enabling the Trusted Platform Module

When enabling the Trusted Platform module, observe the following guidelines:

- By default, the Trusted Platform Module is enabled as TPM 2.0 when the compute module is powered on after installing it.
- In UEFI Boot Mode, the Trusted Platform Module can be configured to operate as TPM 2.0 or TPM 1.2.
- In Legacy Boot Mode, the Trusted Platform Module configuration can be changed between TPM 1.2 and TPM 2.0, but only TPM 1.2 operation is supported.

Enabling the Trusted Platform Module as TPM 2.0

Procedure

1. During the compute module startup sequence, press the **F9** key to access **System Utilities**.
2. From the System Utilities screen, select **System Configuration > BIOS/Platform Configuration (RBSU) > Server Security > Trusted Platform Module options**.
3. Verify the following:
 - "Current TPM Type" is set to **TPM 2.0**.
 - "Current TPM State" is set to **Present and Enabled**.
 - "TPM Visibility" is set to **Visible**.
4. If changes were made in the previous step, press the **F10** key to save your selection.
5. If F10 was pressed in the previous step, do one of the following:
 - If in graphical mode, click **Yes**.
 - If in text mode, press the **Y** key.
6. Press the **ESC** key to exit System Utilities.
7. If changes were made and saved, the compute module prompts for reboot request. Press the **Enter** key to confirm reboot.

If the following actions were performed, the compute module reboots a second time without user input. During this reboot, the TPM setting becomes effective.

 - Changing from TPM 1.2 and TPM 2.0
 - Changing TPM bus from FIFO to CRB
 - Enabling or disabling TPM
 - Clearing the TPM
8. Enable TPM functionality in the OS, such as Microsoft Windows BitLocker or measured boot.

For more information, see the [Microsoft website](#).

Enabling the Trusted Platform Module as TPM 1.2

Procedure

1. During the compute module startup sequence, press the **F9** key to access **System Utilities**.
2. From the System Utilities screen select **System Configuration > BIOS/Platform Configuration (RBSU) > Server Security > Trusted Platform Module options**.
3. Change the "TPM Mode Switch Operation" to **TPM 1.2**.
4. Verify "TPM Visibility" is **Visible**.
5. Press the **F10** key to save your selection.
6. When prompted to save the change in System Utilities, do one of the following:

- If in graphical mode, click **Yes**.
- If in text mode, press the **Y** key.

7. Press the **ESC** key to exit System Utilities.

The compute module reboots a second time without user input. During this reboot, the TPM setting becomes effective.

8. Enable TPM functionality in the OS, such as Microsoft Windows BitLocker or measured boot.

For more information, see the [Microsoft website](#).

Retaining the recovery key/password

The recovery key/password is generated during BitLocker setup, and can be saved and printed after BitLocker is enabled. When using BitLocker, always retain the recovery key/password. The recovery key/password is required to enter Recovery Mode after BitLocker detects a possible compromise of system integrity.

To help ensure maximum security, observe the following guidelines when retaining the recovery key/password:

- Always store the recovery key/password in multiple locations.
- Always store copies of the recovery key/password away from the compute module.
- Do not save the recovery key/password on the encrypted hard drive.

Cabling

Cabling resources

Cabling configurations and requirements vary depending on the product and installed options. For more information about product features, specifications, options, configurations, and compatibility, see the product QuickSpecs on the Hewlett Packard Enterprise website (<http://www.hpe.com/info/qs>).

Energy pack option cabling

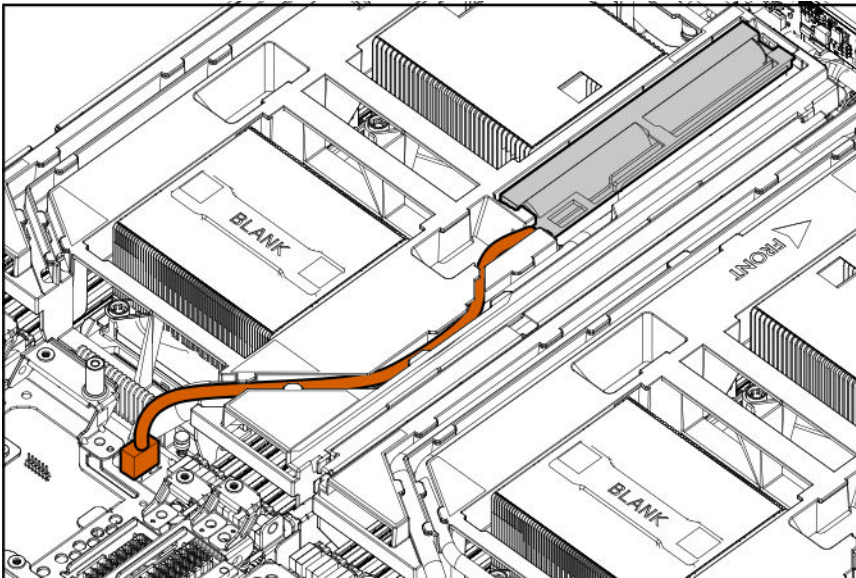

Standard drive backplane cabling

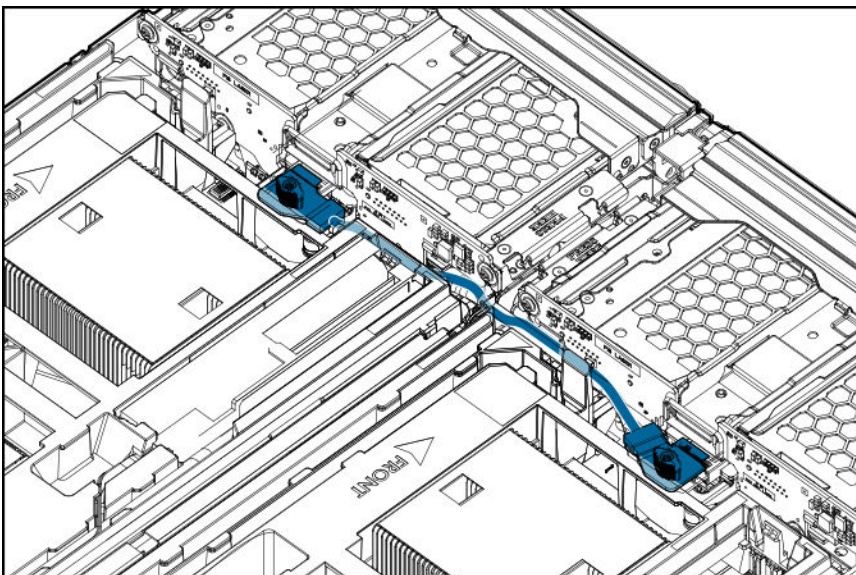

P416ie-m Smart Array Controller cabling

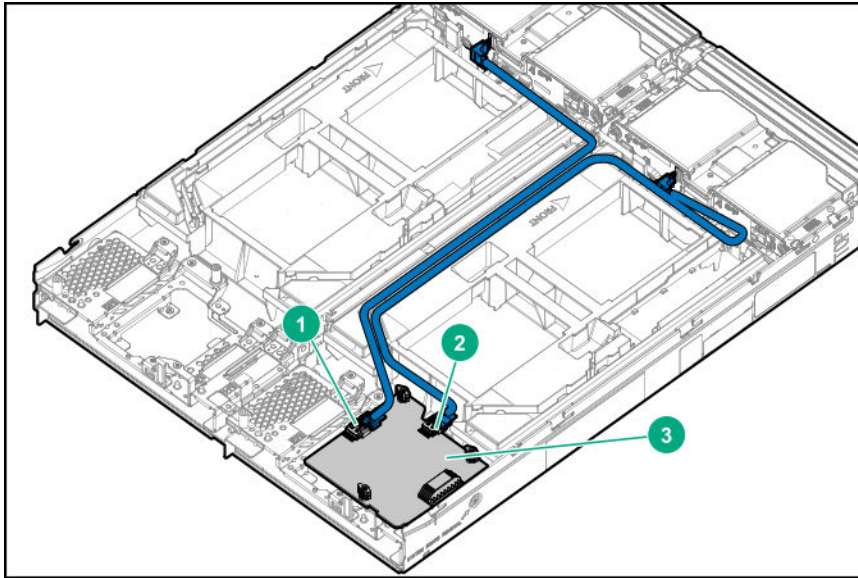

Item	Description
1	Port3i - SAS/SATA cable connector
2	Port4i - SAS/SATA cable connector
3	Mezzanine option card

Removing and replacing the system battery

If the compute module no longer automatically displays the correct date and time, then replace the battery that provides power to the real-time clock. Under normal use, battery life is 5 to 10 years.

⚠ WARNING: The computer contains an internal lithium manganese dioxide, a vanadium pentoxide, or an alkaline battery pack. A risk of fire and burns exists if the battery pack is not properly handled. To reduce the risk of personal injury:

- Do not attempt to recharge the battery.
- Do not expose the battery to temperatures higher than 60°C (140°F).
- Do not disassemble, crush, puncture, short external contacts, or dispose of in fire or water.
- Replace only with the spare designated for this product.

To remove the component:

Procedure

1. **Power down the compute module .**
2. **Remove the compute module .**
3. Place the compute module on a flat, level work surface.
on a flat, level work surface. Place the
4. **Remove the access panel.**
5. **Remove front panel/drive cage assembly.**
6. **Locate the battery on the system board.**
7. Remove the battery.

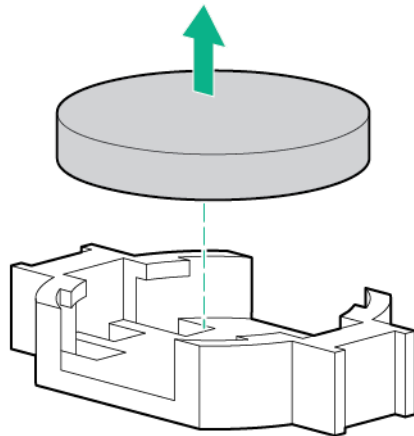

ⓘ IMPORTANT: Replacing the system board battery resets the system ROM to its default configuration. After replacing the battery, use BIOS/Platform Configuration (RBSU) in the UEFI System Utilities to reconfigure the system.

To replace the component, reverse the removal procedure.

For more information about battery replacement or proper disposal, contact an authorized reseller or an authorized service provider.

Electrostatic discharge

Preventing electrostatic discharge

To prevent damaging the system, be aware of the precautions you must follow when setting up the system or handling parts. A discharge of static electricity from a finger or other conductor may damage system boards or other static-sensitive devices. This type of damage may reduce the life expectancy of the device.

Procedure

- Avoid hand contact by transporting and storing products in static-safe containers.
- Keep electrostatic-sensitive parts in their containers until they arrive at static-free workstations.
- Place parts on a grounded surface before removing them from their containers.
- Avoid touching pins, leads, or circuitry.
- Always be properly grounded when touching a static-sensitive component or assembly.

Grounding methods to prevent electrostatic discharge

Several methods are used for grounding. Use one or more of the following methods when handling or installing electrostatic-sensitive parts:

- Use a wrist strap connected by a ground cord to a grounded workstation or computer chassis. Wrist straps are flexible straps with a minimum of 1 megohm \pm 10 percent resistance in the ground cords. To provide proper ground, wear the strap snug against the skin.
- Use heel straps, toe straps, or boot straps at standing workstations. Wear the straps on both feet when standing on conductive floors or dissipating floor mats.
- Use conductive field service tools.
- Use a portable field service kit with a folding static-dissipating work mat.

If you do not have any of the suggested equipment for proper grounding, have an authorized reseller install the part.

For more information on static electricity or assistance with product installation, contact the **Hewlett Packard Enterprise Support Center**.

Specifications

Environmental specifications

Specification	Value
Temperature range¹	—
Operating	10°C to 35°C (50°F to 95°F)
Nonoperating	-30°C to 60°C (-22°F to 140°F)
Relative humidity (noncondensing)²	—
Operating	10% to 90% @ 28°C (82.4°F)
Nonoperating	5% to 95% @ 38.7°C (101.7°F)
Altitude³	—
Operating	3,050 m (10,000 ft)
Nonoperating	9,144 m (30,000 ft)

¹ The following temperature conditions and limitations apply:

- All temperature ratings shown are for sea level.
- An altitude derating of 1°C per 304.8 m (1.8°F per 1,000 ft) up to 3,048 m (10,000 ft) applies.
- No direct sunlight is allowed.
- The maximum permissible rate of change is 10°C/hr (18°F/hr).
- The type and number of options installed might reduce the upper temperature and humidity limits.
- Operating with a fan fault or above 30°C (86°F) might reduce system performance.

² Storage maximum humidity of 95% is based on a maximum temperature of 45°C (113°F).

³ Maximum storage altitude corresponds to a minimum pressure of 70 kPa (10.1 psia).

Physical specifications

Specification	Value
Height	430.30 mm (16.94 in)
Depth	606.6 mm (23.88 in)
Width	63.50 mm (2.50 in)
Weight (maximum)	17.41 kg (38.38 lb)
Weight (minimum)	13.75 kg (30.31 lb)

Documentation and troubleshooting resources for HPE Synergy

HPE Synergy documentation

The Hewlett Packard Enterprise Information Library (www.hpe.com/info/synergy-docs) is a task-based repository. It includes installation instructions, user guides, maintenance and service guides, best practices, and links to additional resources. Use this website to obtain the latest documentation, including:

- Learning about HPE Synergy technology
- Installing and cabling HPE Synergy
- Updating the HPE Synergy components
- Using and managing HPE Synergy
- Troubleshooting HPE Synergy

HPE Synergy Configuration and Compatibility Guide

The *HPE Synergy Configuration and Compatibility Guide* is in the Hewlett Packard Enterprise Information Library (www.hpe.com/info/synergy-docs). It provides an overview of HPE Synergy management and fabric architecture, detailed hardware component identification and configuration, and cabling examples.

HPE Synergy Frame Link Module User Guide

The *HPE Synergy Frame Link Module User Guide* is in the Hewlett Packard Enterprise Information Library (www.hpe.com/info/synergy-docs). It outlines frame link module management, configuration, and security.

HPE OneView User Guide and Help for HPE Synergy

The *HPE OneView User Guide and Help for HPE Synergy* is in the Hewlett Packard Enterprise Information Library (www.hpe.com/info/synergy-docs). It describes resource features, planning tasks, configuration quick start tasks, navigational tools for the graphical user interface, and more support and reference information for HPE OneView.

HPE OneView Global Dashboard User Guide and Help

The HPE OneView Global Dashboard provides a unified view of health, alerting, and key resources managed by HPE OneView across multiple platforms and data center sites. The *HPE OneView Global Dashboard User Guide* is in the Hewlett Packard Enterprise Information Library (www.hpe.com/info/synergy-docs). It provides instructions for installing, configuring, navigating, and troubleshooting the HPE OneView Global Dashboard.

HPE Synergy Image Streamer User Guide

The *HPE Synergy Image Streamer User Guide* is in the Hewlett Packard Enterprise Information Library (www.hpe.com/info/synergy-docs). It describes the OS deployment process using Image Streamer, features of Image Streamer, and purpose and life cycle of Image Streamer artifacts. It also includes authentication, authorization, and troubleshooting information for Image Streamer.

HPE Synergy Image Streamer GitHub

The HPE Synergy Image Streamer GitHub repository (github.com/HewlettPackard) contains sample artifacts and documentation on how to use the sample artifacts. It also contains technical white papers explaining deployment steps that can be performed using Image Streamer.

HPE Synergy Software Overview Guide

The *HPE Synergy Software Overview Guide* is in the Hewlett Packard Enterprise Information Library (www.hpe.com/info/synergy-docs). It provides detailed references and overviews of the various software and configuration utilities to support HPE Synergy. The guide is task-based and covers the documentation and resources for all supported software and configuration utilities available for:

- HPE Synergy setup and configuration
- OS deployment
- Firmware updates
- Troubleshooting
- Remote support

HPE OneView for Synergy Firmware and Driver Update Guide

The *HPE OneView for Synergy Firmware and Driver Update Guide* is in the Hewlett Packard Enterprise Information Library (www.hpe.com/info/synergy-docs). It provides information on how to update the firmware and recommended best practices to update firmware and drivers through HPE Synergy Composer, which is powered by HPE OneView.

HPE OneView Support Matrix for HPE Synergy

The *HPE OneView Support Matrix for HPE Synergy* is in the Hewlett Packard Enterprise Information Library (www.hpe.com/info/synergy-docs). It maintains the latest software and firmware requirements, supported hardware, and configuration maximums for HPE OneView.

HPE Synergy Image Streamer Support Matrix

The *HPE Synergy Image Streamer Support Matrix* is in the Hewlett Packard Enterprise Information Library (www.hpe.com/info/synergy-docs). It maintains the latest software and firmware requirements, supported hardware, and configuration maximums for HPE Synergy Image Streamer.

HPE Synergy Firmware Comparison Tool

The HPE Synergy Firmware Comparison Tool is on the Hewlett Packard Enterprise website (<http://www.hpe.com/info/synergy-fw-comparison-tool>). HPE Synergy Software Releases are made up of a management combination and an HPE Synergy Custom SPP. This tool provides a list of Management Combinations and lets you compare HPE Synergy SPPs supported by the selected management combination.

HPE Synergy Upgrade Paths

The HPE Synergy Upgrade Paths is a table on the Hewlett Packard Enterprise website (<http://www.hpe.com/info/synergy-fw-upgrade-table>). The table provides information on HPE Synergy Composer and HPE Synergy Image Streamer upgrade paths and management combinations.

HPE Synergy Glossary

The *HPE Synergy Glossary*, in the Hewlett Packard Enterprise Information Library (www.hpe.com/info/synergy-docs), defines common terminology associated with HPE Synergy.

HPE Synergy troubleshooting resources

HPE Synergy troubleshooting resources are available within HPE OneView and in the Hewlett Packard Enterprise Information Library (www.hpe.com/info/synergy-docs).

Troubleshooting within HPE OneView

HPE OneView graphical user interface includes alert notifications and options for troubleshooting within HPE OneView. The UI provides multiple views of HPE Synergy components, including colored icons to indicate resource status and potential problem resolution in messages.

You can also use the Enclosure view and Map view to quickly see the status of all discovered HPE Synergy hardware.

HPE Synergy Troubleshooting Guide

The *HPE Synergy Troubleshooting Guide* is in the Hewlett Packard Enterprise Information Library (www.hpe.com/info/synergy-docs). It provides information for resolving common problems and courses of action for fault isolation and identification, issue resolution, and maintenance for both HPE Synergy hardware and software components.

Error Message Guide for HPE ProLiant Gen10 servers and HPE Synergy

The *Error Message Guide for HPE ProLiant Gen10 servers and HPE Synergy* is in the Hewlett Packard Enterprise Information Library (www.hpe.com/info/synergy-docs). It provides information for resolving common problems associated with specific error messages received for both HPE Synergy hardware and software components.

HPE OneView Help and HPE OneView API Reference

The *HPE OneView Help* and the *HPE OneView API Reference* are readily accessible, embedded online help available within the HPE OneView user interface. These help files include “Learn more” links to common issues, as well as procedures and examples to troubleshoot issues within HPE Synergy.

The help files are also available in the Hewlett Packard Enterprise Information Library (www.hpe.com/info/synergy-docs).

HPE Synergy QuickSpecs

HPE Synergy has system specifications as well as individual product and component specifications. For complete specification information, see the HPE Synergy and individual HPE Synergy product QuickSpecs on the Hewlett Packard Enterprise website (www.hpe.com/info/qs).

HPE Synergy document overview (documentation map)

www.hpe.com/info/synergy-docs

Planning

- *HPE Synergy 12000 Frame Site Planning Guide*
- *HPE Synergy Configuration and Compatibility Guide*
- *HPE OneView Support Matrix for HPE Synergy*
- *HPE Synergy Image Streamer Support Matrix*
- *Setup Overview for HPE Synergy*
- *HPE Synergy Software Overview Guide*

Installing hardware

- *HPE Synergy Start Here Poster* (included with frame)
- *HPE Synergy 12000 Frame Setup and Installation Guide*
- *Rack Rails Installation Instructions for the HPE Synergy 12000 Frame* (included with frame)
- *HPE Synergy 12000 Frame Rack Template* (included with frame)
- Hood labels
- User guides
- *HPE Synergy Cabling Interactive Guide*
- *HPE OneView Help for HPE Synergy — Hardware setup*

Configuring for managing and monitoring

- *HPE OneView Help for HPE Synergy*
- *HPE OneView User Guide for HPE Synergy*
- *HPE OneView API Reference for HPE Synergy*
- User Guides
- HPE Synergy Firmware Comparison Tool
- HPE Synergy Upgrade Paths (website)

Managing

- *HPE OneView User Guide for HPE Synergy*
- *HPE Synergy Image Streamer Help*
- *HPE Synergy Image Streamer User Guide*
- *HPE Synergy Image Streamer API Reference*
- *HPE Synergy Image Streamer deployment workflow*
- *HPE Synergy Frame Link Module User Guide*

Monitoring

- *HPE OneView User Guide for HPE Synergy*
- *HPE OneView Global Dashboard User Guide*

Maintaining

- Product maintenance and service guides
- *HPE OneView for Synergy Firmware and Driver Update Guide*
- *HPE OneView Help for HPE Synergy*
- *HPE OneView User Guide for HPE Synergy*
- *HPE Synergy Appliances Maintenance and Service Guide*

Troubleshooting

- HPE OneView alert details
- *HPE Synergy Troubleshooting Guide*
- *Error Message Guide for HPE ProLiant Gen10 servers and HPE Synergy*
- *Integrated Management Log Messages and Troubleshooting Guide for HPE ProLiant Gen10 and HPE Synergy*
- *HPE OneView API Reference for HPE Synergy*
- *HPE Synergy Image Streamer API Reference*

Websites

General websites

Hewlett Packard Enterprise Information Library

www.hpe.com/info/EIL

Single Point of Connectivity Knowledge (SPOCK) Storage compatibility matrix

www.hpe.com/storage/spock

Storage white papers and analyst reports

www.hpe.com/storage/whitepapers

For additional websites, see [Support and other resources](#).

Support and other resources

Accessing Hewlett Packard Enterprise Support

- For live assistance, go to the Contact Hewlett Packard Enterprise Worldwide website:
<http://www.hpe.com/info/assistance>
- To access documentation and support services, go to the Hewlett Packard Enterprise Support Center website:
<http://www.hpe.com/support/hpesc>

Information to collect

- Technical support registration number (if applicable)
- Product name, model or version, and serial number
- Operating system name and version
- Firmware version
- Error messages
- Product-specific reports and logs
- Add-on products or components
- Third-party products or components

Accessing updates

- Some software products provide a mechanism for accessing software updates through the product interface. Review your product documentation to identify the recommended software update method.
- To download product updates:
Hewlett Packard Enterprise Support Center
www.hpe.com/support/hpesc
Hewlett Packard Enterprise Support Center: Software downloads
www.hpe.com/support/downloads
Software Depot
www.hpe.com/support/softwaredepot
- To subscribe to eNewsletters and alerts:
www.hpe.com/support/e-updates
- To view and update your entitlements, and to link your contracts and warranties with your profile, go to the Hewlett Packard Enterprise Support Center **More Information on Access to Support Materials** page:
www.hpe.com/support/AccessToSupportMaterials

 **IMPORTANT:** Access to some updates might require product entitlement when accessed through the Hewlett Packard Enterprise Support Center. You must have an HPE Passport set up with relevant entitlements.

Customer self repair

Hewlett Packard Enterprise customer self repair (CSR) programs allow you to repair your product. If a CSR part needs to be replaced, it will be shipped directly to you so that you can install it at your convenience. Some parts do not qualify for CSR. Your Hewlett Packard Enterprise authorized service provider will determine whether a repair can be accomplished by CSR.

For more information about CSR, contact your local service provider or go to the CSR website:

<http://www.hpe.com/support/selfrepair>

Remote support

Remote support is available with supported devices as part of your warranty or contractual support agreement. It provides intelligent event diagnosis, and automatic, secure submission of hardware event notifications to Hewlett Packard Enterprise, which will initiate a fast and accurate resolution based on your product's service level. Hewlett Packard Enterprise strongly recommends that you register your device for remote support.

If your product includes additional remote support details, use search to locate that information.

Remote support and Proactive Care information

HPE Get Connected

www.hpe.com/services/getconnected

HPE Proactive Care services

www.hpe.com/services/proactivecare

HPE Proactive Care service: Supported products list

www.hpe.com/services/proactivecaresupportedproducts

HPE Proactive Care advanced service: Supported products list

www.hpe.com/services/proactivecareadvancedsupportedproducts

Proactive Care customer information

Proactive Care central

www.hpe.com/services/proactivecarecentral

Proactive Care service activation

www.hpe.com/services/proactivecarecentralgetstarted

Warranty information

To view the warranty information for your product, see the links provided below:

HPE ProLiant and IA-32 Servers and Options

www.hpe.com/support/ProLiantServers-Warranties

HPE Enterprise and Cloudline Servers

www.hpe.com/support/EnterpriseServers-Warranties

HPE Storage Products

www.hpe.com/support/Storage-Warranties

HPE Networking Products

www.hpe.com/support/Networking-Warranties

Regulatory information

To view the regulatory information for your product, view the *Safety and Compliance Information for Server, Storage, Power, Networking, and Rack Products*, available at the Hewlett Packard Enterprise Support Center:

www.hpe.com/support/Safety-Compliance-EnterpriseProducts

Additional regulatory information

Hewlett Packard Enterprise is committed to providing our customers with information about the chemical substances in our products as needed to comply with legal requirements such as REACH (Regulation EC No 1907/2006 of the European Parliament and the Council). A chemical information report for this product can be found at:

www.hpe.com/info/reach

For Hewlett Packard Enterprise product environmental and safety information and compliance data, including RoHS and REACH, see:

www.hpe.com/info/ecodata

For Hewlett Packard Enterprise environmental information, including company programs, product recycling, and energy efficiency, see:

www.hpe.com/info/environment

Documentation feedback

Hewlett Packard Enterprise is committed to providing documentation that meets your needs. To help us improve the documentation, send any errors, suggestions, or comments to Documentation Feedback (docsfeedback@hpe.com). When submitting your feedback, include the document title, part number, edition, and publication date located on the front cover of the document. For online help content, include the product name, product version, help edition, and publication date located on the legal notices page.