

## QSFP-SFP10G-CVR-AO

MSA and TAA Compliant 10GBase-Converter QSFP+ Transceiver (QSFP+ to SFP+ Converter)

### Features

- Compliant to industry standards
- QSFP MSA SFF-8436
- SFP+ MSA SFF-8431
- Low insertion loss
- Matched impedance
- Secure latching mechanism
- Built-in EEPROM for product identification
- RoHS-6 compliant

### Applications

- Low EMI radiation Switches, servers and routers
- Telecommunication and wireless infrastructure
- Test and measurement equipment
- Networked storage systems
- Data Center networks

### Product Description

This MSA compliant QSFP+ to SFP+ converter provides conversion from QSFP+ to SFP+ form factors. It is built to MSA standards and is uniquely serialized and data-traffic and application tested to ensure that it will integrate into your network seamlessly. It is built to meet or exceed the specifications of MSA Compliant, as well as to comply with MSA (Multi-Source Agreement) standards to ensure seamless network integration. This converter is Trade Agreements Act (TAA) compliant. We stand behind the quality of our products and proudly offer a limited lifetime warranty.

AddOn's QSFP+ to SFP+ converters are RoHS compliant and lead-free.

TAA refers to the Trade Agreements Act (19 U.S.C. & 2501-2581), which is intended to foster fair and open international trade. TAA requires that the U.S. Government may acquire only "U.S. – made or designated country end products."



### Regulatory Compliance

- ESD to the Electrical PINs: compatible with MIL-STD-883E Method 3015.4
- ESD to the LC Receptacle: compatible with IEC 61000-4-3
- EMI/EMC compatible with FCC Part 15 Subpart B Rules, EN55022:2010
- Laser Eye Safety compatible with FDA 21CFR, EN60950-1& EN (IEC) 60825-1,2
- RoHS compliant with EU RoHS 2.0 directive 2015/863/EU

### Recommended Operating Conditions

Parameter	Symbol	Min	Max	Unit
Operating Case Temperature	Topc	-20	85	degC
Storage Temperature	Tst	-40	85	degC
Relative Humidity (non-condensation)	RS		85	%
Supply Voltage	VCC3	3.15	3.45	V
Power consumption	Pout		0.3	W
Characteristic Impedance	Im	90	110	Ohm

### QSFP Host board Connector Pinout

#### MSA compliant Connector

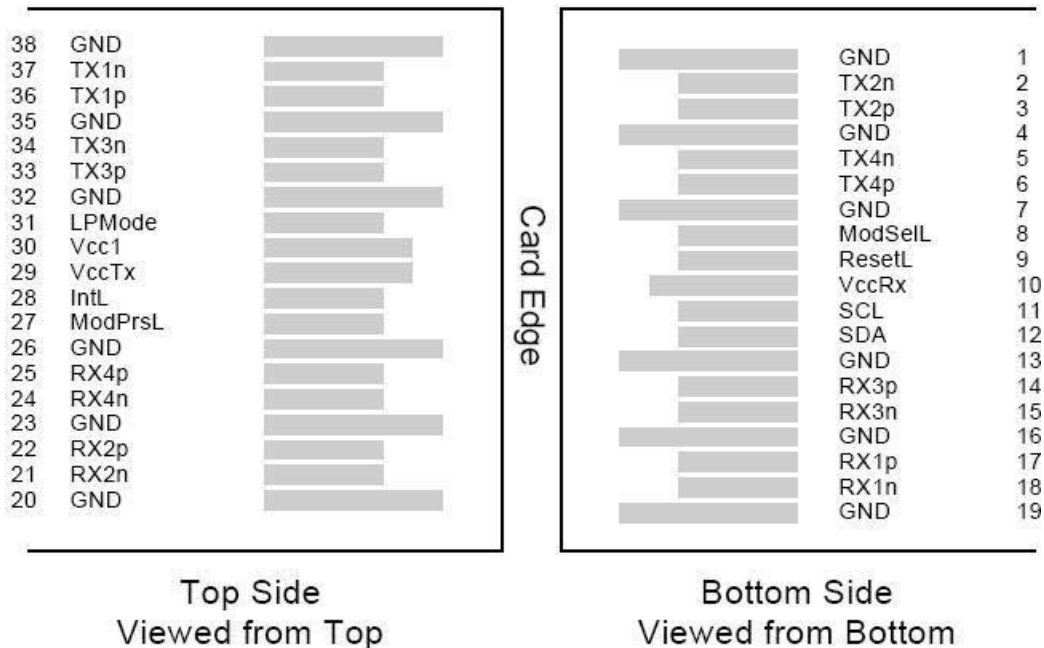

## Pin Definitions

Pin	Logic	Symbol	Name/Description	Note
1		GND	Ground	1
2	CML-I	Tx2n	Transmitter Inverted Data Input	
3	CML-I	Tx2p	Transmitter Non-Inverted Data output	
4		GND	Ground	1
5	CML-I	Tx4n	Transmitter Inverted Data Input	
6	CML-I	Tx4p	Transmitter Non-Inverted Data output	
7		GND	Ground	1
8	LVTLL-I	ModSelL	Module Select	
9	LVTLL-I	ResetL	Module Reset	
10		VccRx	+ 3.3V Power Supply Receiver	2
11	LVC MOS-I/O	SCL	2-Wire Serial Interface Clock	
12	LVC MOS-I/O	SDA	2-Wire Serial Interface Data	
13		GND	Ground	
14	CML-O	Rx3p	Receiver Non-Inverted Data Output	
15	CML-O	Rx3n	Receiver Inverted Data Output	
16		GND	Ground	1
17	CML-O	Rx1p	Receiver Non-Inverted Data Output	
18	CML-O	Rx1n	Receiver Inverted Data Output	
19		GND	Ground	1
20		GND	Ground	1
21	CML-O	Rx2n	Receiver Inverted Data Output	
22	CML-O	Rx2p	Receiver Non-Inverted Data Output	
23		GND	Ground	1
24	CML-O	Rx4n	Receiver Inverted Data Output	1
25	CML-O	Rx4p	Receiver Non-Inverted Data Output	
26		GND	Ground	1
27	LVTTL-O	ModPrsL	Module Present	
28	LVTTL-O	IntL	Interrupt	
29		VccTx	+3.3 V Power Supply transmitter	2
30		Vcc1	+3.3 V Power Supply	2
31	LVTTL-I	LPMODE	Low Power Mode	
32		GND	Ground	1
33	CML-I	Tx3p	Transmitter Non-Inverted Data Input	
34	CML-I	Tx3n	Transmitter Inverted Data Output	

35		GND	Ground	1
36	CML-I	Tx1p	Transmitter Non-Inverted Data Input	
37	CML-I	Tx1n	Transmitter Inverted Data Output	
38		GND	Ground	1

**Note:**

1. GND is the symbol for signal and supply (power) common for QSFP modules. All are common within the QSFP module and all module voltages are referenced to this potential otherwise noted. Connect these directly to the host board signal common ground plane
2. cc Rx, Vcc1 and Vcc Tx are the receiver and transmitter power suppliers and shall be applied concurrently. Recommended host board power supply filtering is shown below. Vcc Rx, Vcc1 and Vcc Tx may be internally connected within the QSFP transceiver module in any combination.

**SFP+ Host board Connector Pinout for SFP+ MSA compliant Connector**

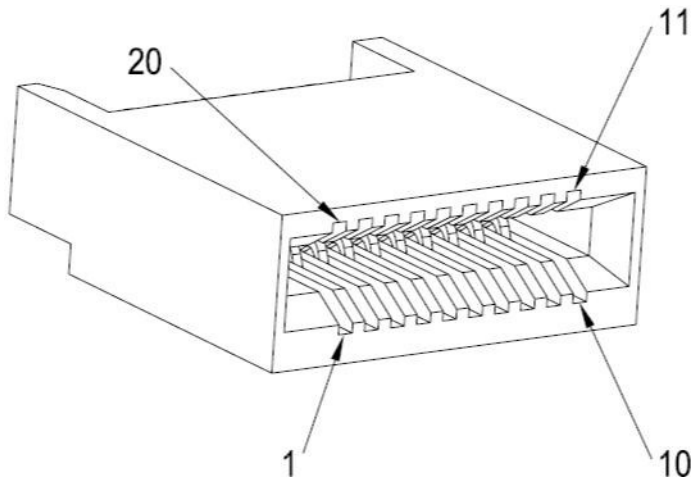

## Pin Definitions

Pin	Logic	Symbol	Name/Description	Note
1		VeeT	Module Transmitter Ground	1
2	LVTTL-O	Tx_Fault	Transmitter Fault	2
3	LVTTL-I	Tx_Disable	Transmitter Disable	3
4	LVTTL-I/O	SDA	MOD-DEF2 2-wire serial interface data line	4
5	LVTTL-I/O	SCL	MOD-DEF1 2-wire serial interface clock line	4
6		Mod_Abs	Module Absent	5
7	LVTTL-I	RS0	Rate Select Zero	
8	LVTTL-O	Rx_LOS	Module Receiver Loss of Signal	2
9	LVTTL-I	RS1	Rate Select One	
10		VeeR	Module Receiver Ground	1
11		VeeR	Module Receiver Ground	1
12	CML-O	RD-	Receiver Inverted Data Output	
13	CML-O	RD+	Receiver Non-Inverted Data Output	
14		VeeR	Module Receiver Ground	1
15		VccR	Module Receiver 3.3V Supply	
16		VccT	Module Transmitter 3.3V Supply	
17		VeeT	Module Transmitter Ground	1
18	CML-I	TD+	Transmitter Non-Inverted Data Input	
19	CML-I	TD-	Transmitter Inverted Data Input	
20		VeeT	Module Transmitter Ground	1

### Notes:

1. The module signal grounds, VeeR and VeeT, shall be isolated from the module case.
2. This is an open collector/drain output and shall be pulled up with 4.7-10k to Vcc\_Host on the host board. Pull ups can be connected to multiple power supplies, however the host board design shall ensure that no module has voltage exceeding module VccT/R + 0.5 V.
3. This is an open collector/drain input and shall be pulled up with 4.7-10k to VccT in the module.
4. See 2-wire electrical specifications.
5. This shall be pulled up with 4.7-10k to Vcc\_Host on the host board.

## Mechanical Dimensions

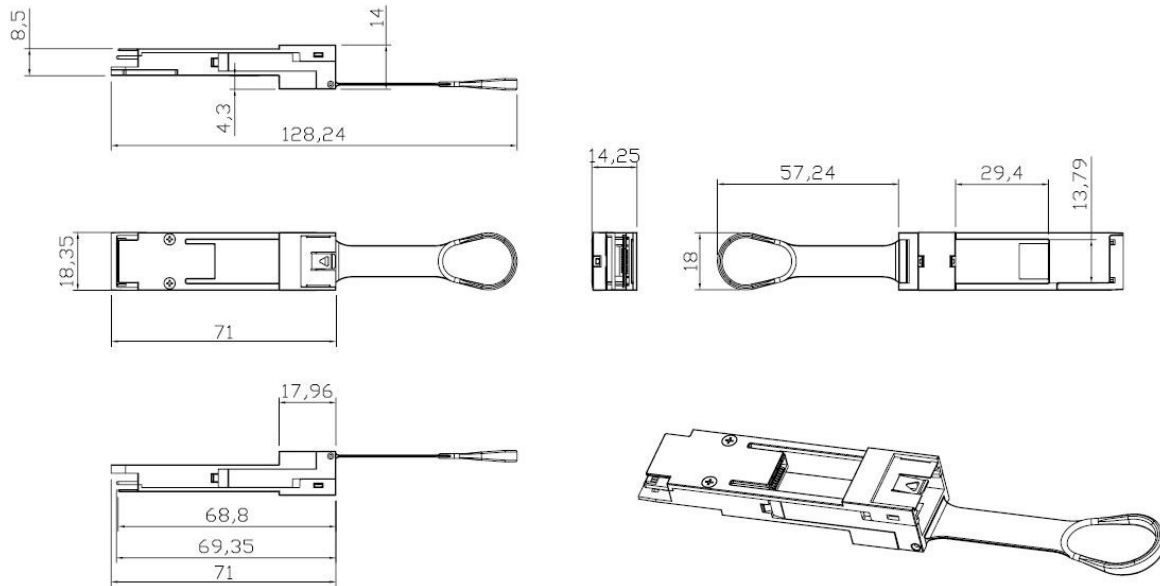

## Physical Specifications

Parameter	Specification
Maximum dimensions (H x W x D)	13.5 x 18.4 x 78 mm
Weight	Typically, less than 100g