

USER GUIDE • GUIDE DE L'UTILISATEUR



Pro Gaming Mouse Bungee

REGISTER NOW



ENREGISTRER

This product comes with a 1 year limited warranty.

Register this product within 30 days of sale to activate a complimentary 2 year warranty extension and receive free advanced technical support. Learn more and register now.

Ce produit est livré avec une garantie limitée de 1 an.

Enregistrez ce produit dans les 30 jours de vente pour activer une extension de garantie de 2 ans gratuite et recevoir un support technique de qualité gratuit. Pour en savoir plus et vous inscrire.

ENHANCEgaming.com/warranty



ENHANCE® VOLTAIC™ MOUSE



ENHANCE® PATHOGEN™ KEYBOARD





ENHANCE® SCORIA™ HEADSET

See more exciting products at:
Voir plus de produits passionnants sur:
Para los productos mas fasinantes visitenos:
Weitere interessante Produkte an:
Scopri altri fantastici prodotti su:
查看更多精彩的产品:

AccessoryPower.com/promo



Need help with this product?

Besoin d'assistance sur ce produit?

¿Necesita ayuda con este producto?

Benötigen Sie Hilfe bei diesem Produkt?

Hai bisogno di aiuto per questo prodotto?

购买的产品，是否需要提供协助？

[ENHANCEgaming.com/support](https://enhancegaming.com/support)

Package contents

L'emballage contient

Contenidos del paquete

Packungsinhalt

Contenuto della confezione

包装内容

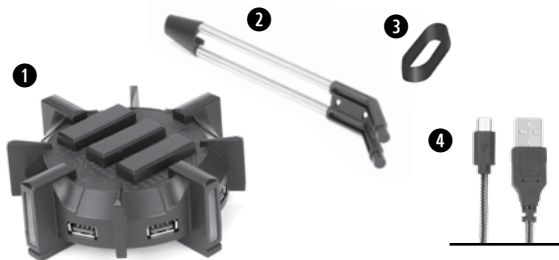

EN

- 1 USB hub base
- 2 Bungee attachment
- 3 Secure loop
- 4 Micro USB cable

FR

- 1 Base de hub USB
- 2 Attache de tendeur
- 3 Boucle de sécurité
- 4 Câble micro USB

ES

- 1 Base hub USB
- 2 Conexión para el elevador
- 3 Nudo de seguridad
- 4 Cable micro USB

DE

- 1 Standfläche mit USB-Hub
- 2 Elastikband-Befestigung
- 3 Sicherheitsschleife
- 4 Mikro-USB-Kabel

IT

- 1 Base hub USB
- 2 Attacco bungee
- 3 Anello chiusura di sicurezza
- 4 Micro cavo USB

ZH

- 1 USB集线器基座
- 2 固线器附件
- 3 固定匝
- 4 小型USB电缆

Product diagram
Schéma du produit
Diagrama de product
Producttabbildung
Schema del prodotto
产品图

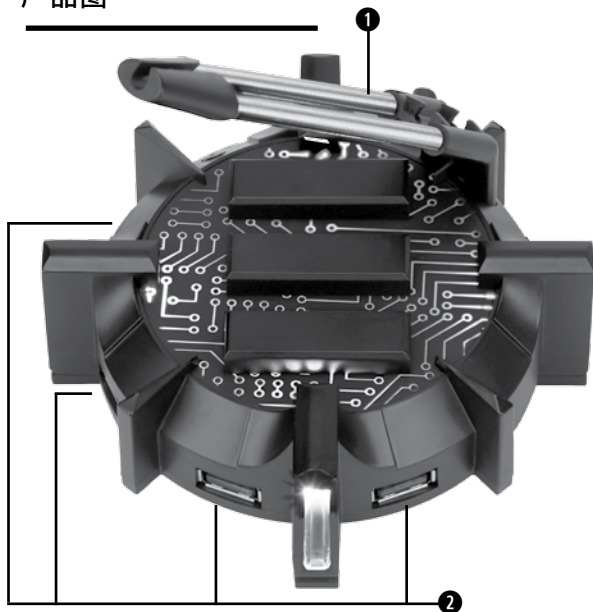

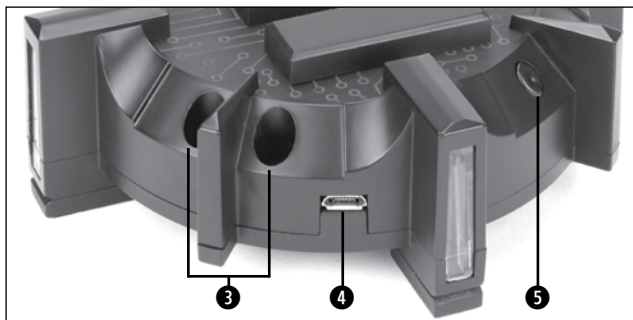
EN

- 1 Cable arm
- 2 4 x USB 2.0 ports
- 3 Attachment slots
- 4 USB cable input
- 5 LED power button

FR

- 1 Bras de câble
- 2 Quatre ports USB 2.0
- 3 Fentes de fixation
- 4 Entrée du câble USB
- 5 Bouton d'alimentation de la DEL

ES

- 1 Brazo para cable
- 2 Cuatro puertos USB 2.0
- 3 Ranuras de conexión
- 4 Entrada de cable USB
- 5 Botón de encendido LED

DE

- 1 Kabelarm
- 2 4x USB-2.0-Anschlüsse
- 3 Steckplätze
- 4 USB-Kabeleingang
- 5 LED-Betriebsleuchte

IT

- 1 Braccio per inserimento cavo
- 2 4 porte USB 2.0
- 3 Spazi per attacchi
- 4 Cavo USB input
- 5 Pulsante accensione luci LED

ZH

- 1 电缆臂
- 2 4个USB 2.0端口
- 3 附件插槽
- 4 USB电缆输入
- 5 LED电源按钮

Operating instructions

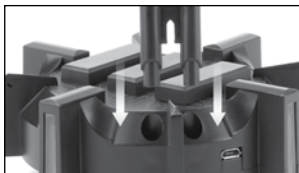

Insert the cable arm into the attachment slots.



Thread the mouse cord through secure loop (optional) and into the groove of the cable arm.



Connect to PC using the Micro USB cable. The drivers will install automatically.



Adjust your mouse cord until movement is unrestricted.



Press the LED power button to turn ON lighting or cycle through the 6 different colors and rainbow mode. Press and hold the LED power button for 3 seconds to turn off lighting.

Mode d'emploi

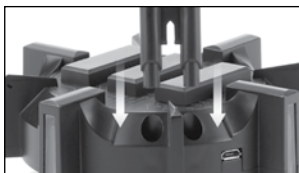

Insérez le bras de câble dans les fentes de fixation.



Passez le câble de la souris dans la boucle de fixation (optionnelle) et dans la rainure du bras de câble.



Connectez à l'ordinateur en utilisant le câble micro USB. Les pilotes seront installés automatiquement.



Ajustez votre câble de souris jusqu'à ce que le mouvement soit libre.



Appuyez sur le bouton d'alimentation de la DEL pour allumer l'éclairage ou parcourez les six différentes couleurs et le mode arc-en-ciel. Appuyez longuement sur le bouton d'alimentation de la DEL pendant trois secondes pour éteindre l'éclairage.

Instrucciones de Operación

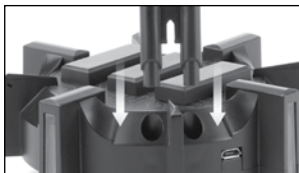

Inserte el brazo para cable en las ranuras de conexión.



Pase el cable del ratón por el nudo de seguridad (opcional) y dentro del canal del brazo para cable.



Conectélo al ordenador mediante el cable micro USB. Los controladores se instalarán automáticamente.



Ajuste el cable del ratón hasta que se pueda mover con total libertad.



Pulse el botón de encendido LED para encender la luz o desplácese por los 6 diferentes colores y el modo multicolor. Mantenga pulsado el botón de encendido LED durante tres segundos para apagar la luz.

Bedienungsanleitung

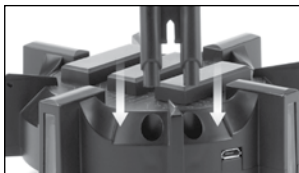

Bringen Sie den Kabelarm an den Steckplätzen an.



Führen Sie das Mauskabel durch die Sicherheitsschleife (optional) und in die Rille des Kabelarms.



Verbinden Sie über das Mikro-USB-Kabel mit dem PC. Die Treiber werden automatisch installiert.



Passen Sie Ihr Mausekabel so an, dass Bewegungen uneingeschränkt sind.



Drücken Sie die LED-Funktionstaste, um die Beleuchtung EINzuschalten, oder gehen Sie reihum durch die 6 verschiedenen Farben und den Regenbogen-Modus. Drücken und halten Sie die LED-Funktionstaste 3 Sekunden lang, um die Beleuchtung auszuschalten.

Istruzioni operative

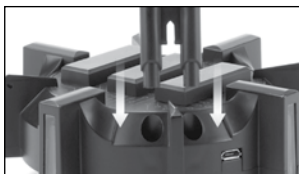

Inserisci il braccio all'interno degli spazi per l'attacco.



Assicura il cavo del mouse attraverso l'anello di sicurezza (opzionale) e dentro la scanalatura del braccio.



Connettiti al PC usando il micro cavo USB. I driver si installeranno automaticamente.



Aggiusta il cavo del mouse fino a che il movimento sarà senza restrizioni.



Schiaccia il pulsante accensione luci LED per accendere le luci o alterna tra i 6 colori differenti e la modalità arcobaleno. Schiaccia e tieni premuto il pulsante accensione LED per 3 secondi per spegnere le luci.

操作指令

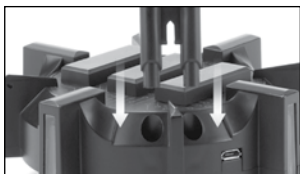

将电缆臂插入附件插槽中。



将鼠标线穿过固定匝（可选），并置入电缆臂的槽中。



通过小型USB电缆连接到电脑，驱动程序会自动安装。



调整鼠标线，直到移动不受限制。



按下LED电源按钮打开照明，或切换6种不同颜色和彩虹模式。按住LED电源按钮3秒钟以关闭照明。

Product specifications

Spécifications du produit

Especificaciones del producto

Produktspezifikationen

Specifiche del prodotto

产品规格

Power input: 5V = 0.5A

USB ports: 4 x USB 2.0

USB power output: 5V = 0.5A (MAX)

Data transfer speed: 480Mbps

Power and data cable length: 47.25 inches

Dimensions (with cable arm): 5.25 x 4.62 x 4.62 inches

Weight: 7.05 ounces

Alimentation électrique: 5V = 0,5A

Ports USB: 4 x USB 2,0

Puissance de sortie USB: 5V = 0,5A (MAX)

Vitesse de transfert des données: 480 Mbps

Longueur du câble d'alimentation et de données: 120 cm

Dimensions (avec le bras porteur): 13,33 x 11,73 x 11,73 cm

Poids: 199,86 g





Pro Gaming Mouse Bungee

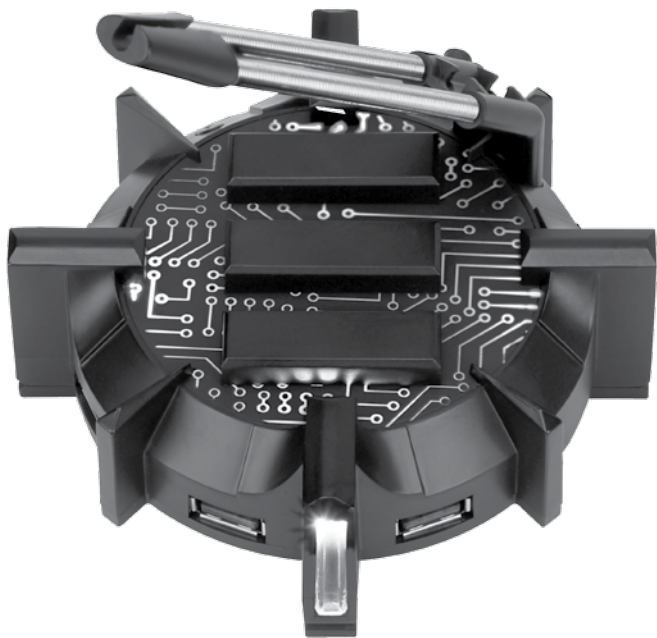

WARRANTY GARANTIE GARANTÍA



GARANTIE GARANZIA 保固

This product comes with a 1 year limited warranty, the acceptance of which is a condition of sale. Register this product within 30 days of sale to activate a complimentary 2 year warranty extension and receive free advanced technical support. For warranty program details, registration, and support visit ENHANCEgaming.com/warranty.

Ce produit est livré avec une garantie limitée de 1 an, la condition étant l'achat du produit. Enregistrer ce produit dans les 30 jours de vente pour activer l'extension de garantie de 2 ans gratuite et recevoir un support technique de qualité gratuit. Pour les détails du programme de garantie, l'enregistrement, et l'assistance visiter ENHANCEgaming.com/warranty.

Este producto viene con una garantía limitada de 1 año, la aceptación de que es una condición de la venta. Registrar este producto dentro de los 30 días de la venta para activar una extensión de cortesía 2 años de garantía y recibir soporte técnico avanzado libre. Para los detalles del programa de garantía, el registro, y una visita de apoyo ENHANCEgaming.com/warranty.

Dieses Produkt kommt mit einer 1-Jahres-Garantie, deren Annahme ist eine Bedingung des Verkaufs. Registrieren Sie dieses Produkt innerhalb von 30 Tagen den Verkauf an ein kostenloses 2 Jahre Garantie-Erweiterung zu aktivieren und erhalten kostenlose erweiterte technische Unterstützung. Für Garantie-Programm Details, Registrierung und Support Besuch ENHANCEgaming.com/warranty.

Questo prodotto viene fornito con una garanzia limitata di 1 anno, la cui accettazione è una condizione di vendita. Registra questo prodotto entro 30 giorni di vendita per attivare tutte le mattine una estensione di garanzia di 2 anni e di ricevere supporto tecnico avanzato gratuito. Per i dettagli del programma di garanzia, la registrazione e supporto visitare ENHANCEgaming.com/warranty.

本产品带有1年有限保修的销售承诺。在购买后30天内注册本产品将获赠2年延长保修及得到免费高级技术支持。关于保修流程的细节、注册和支持，请访问ENHANCEgaming.com/warranty。

© 2017 AP Global, Inc. All rights reserved. Accessory Power, the Accessory Power logo, ENHANCE, the ENHANCE logo and other Accessory Power marks and logos are either registered trademarks or trademarks of AP Global, Inc. in the United States and/or other countries. All other trademarks are the property of their respective owners.

Manufactured in China. Designed in California.

© 2017 AP Global, Inc. Tous droits réservés. Accessory Power, le logo Accessory Power, ENHANCE le logo ENHANCE et les autres marques et logos d'Accessory Power sont soit des marques déposées soit des marques de AP Global, Inc. aux États-Unis et/ou dans d'autres pays. Toutes les autres marques sont la propriété de leurs propriétaires respectifs.

Fabriqué en Chine. Conçu en Californie.



ENHANCEgaming.com



[Facebook.com/ENHANCEgaming](https://www.facebook.com/ENHANCEgaming)



ENHANCE

Pro Gaming Mouse Bungee

MODEL NUMBER: ENPCGHB100BKEW

ENHANCEgaming.com/recycle

