

# MUIP-2213

13.3" LCD User Interface

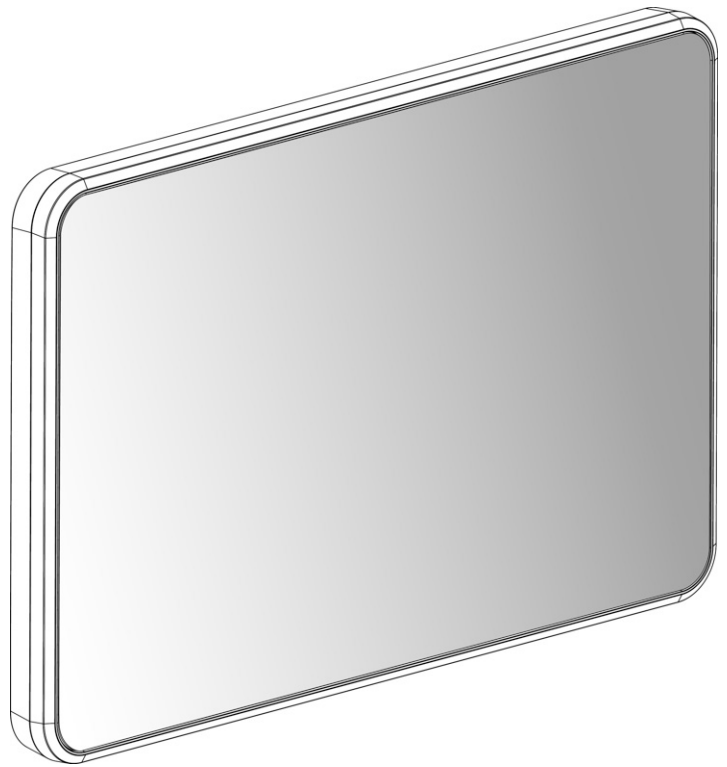

User Guide

**Barco NV**  
Beneluxpark 21, 8500 Kortrijk, Belgium  
[www.barco.com](http://www.barco.com)

**Manufacturer: Barco NV**  
President Kennedypark 35, 8500 Kortrijk, Belgium

## Copyright notice

This document is copyrighted. All rights are reserved. Neither this document, nor any part of it, may be reproduced or copied in any form or by any means - graphical, electronic, or mechanical including photocopying, taping or information storage and retrieval systems - without written permission of Barco.

© 2025 Barco NV all rights reserved.

## Disclaimer notice

Although every attempt has been made to achieve technical accuracy in this document, we assume no responsibility for errors that may be found. Our goal is to provide you with the most accurate and usable documentation possible; if you discover errors, please let us know.

Barco software products are the property of Barco. They are distributed under copyright by Barco NV or Barco Inc., for use only under the specific terms of a software license agreement between Barco NV or Barco Inc. and the licensee. No other use, duplication, or disclosure of a Barco software product, in any form, is authorized.

The specifications of Barco products are subject to change without notice.

## Trademarks

All trademarks and registered trademarks are property of their respective owners.

USB Type-C® and USB-C® are a registered trademarks of USB Implementers Forum.

## Technical assistance

For any technical assistance, please visit [www.barco.com/support](http://www.barco.com/support).

## Patent protection

Please refer to [www.barco.com/about-barco/legal/patents](http://www.barco.com/about-barco/legal/patents).

## Product Security Incident Response

As a global technology leader, Barco is committed to deliver secure solutions and services to our customers, while protecting Barco's intellectual property.

When product security concerns are received, the product security incident response process will be triggered immediately. To address specific security concerns or to report security issues with Barco products, please inform us via contact details mentioned on <https://www.barco.com/psirt>.

To protect our customers, Barco does not publicly disclose or confirm security vulnerabilities until Barco has conducted an analysis of the product and issued fixes and/or mitigations.



# Table of contents

<b>1</b>	<b>Welcome!</b>	<b>7</b>
1.1	What's in the box	8
1.2	Product overview	8
<b>2</b>	<b>Installation</b>	<b>11</b>
2.1	Cable connections	12
2.2	Cable routing	13
2.3	Desktop support installation (optional)	15
<b>3</b>	<b>Maintenance</b>	<b>17</b>
3.1	Scheduled maintenance	18
3.2	Cleaning	18
<b>4</b>	<b>Important information</b>	<b>19</b>
4.1	Safety information	20
4.2	Cybersecurity	24
4.3	Environmental information	24
4.4	Biological hazard and returns – Decommissioning	26
4.5	Regulatory information	27
4.6	EMC notice	28
4.7	Explanation of symbols	31
4.8	Technical specifications	34



# Welcome!

# 1

## Warnings, cautions, notes and tips

There are four levels of precautionary or advisory statements that may be used in this user guide. In descending order of importance, they are:



**WARNING:** Describes hazards or dangers that might result in personal injury or death.



**CAUTION:** Describes hazards that could damage the product.



Gives additional information about the described subject.



Gives extra advice about the described subject.

## 1.1 What's in the box

### Overview

- MUIP-2213 13.3" LCD User Interface
- Power supply 19V 65W AC-DC external unit (depending on type)
- Power cord provided according to final country destination; not provided for the configuration without power supply.
- 1x printed User Guide (English)



Keep your original packaging. It is designed for this display and is the ideal protection during transport and storage.

## 1.2 Product overview

### Front

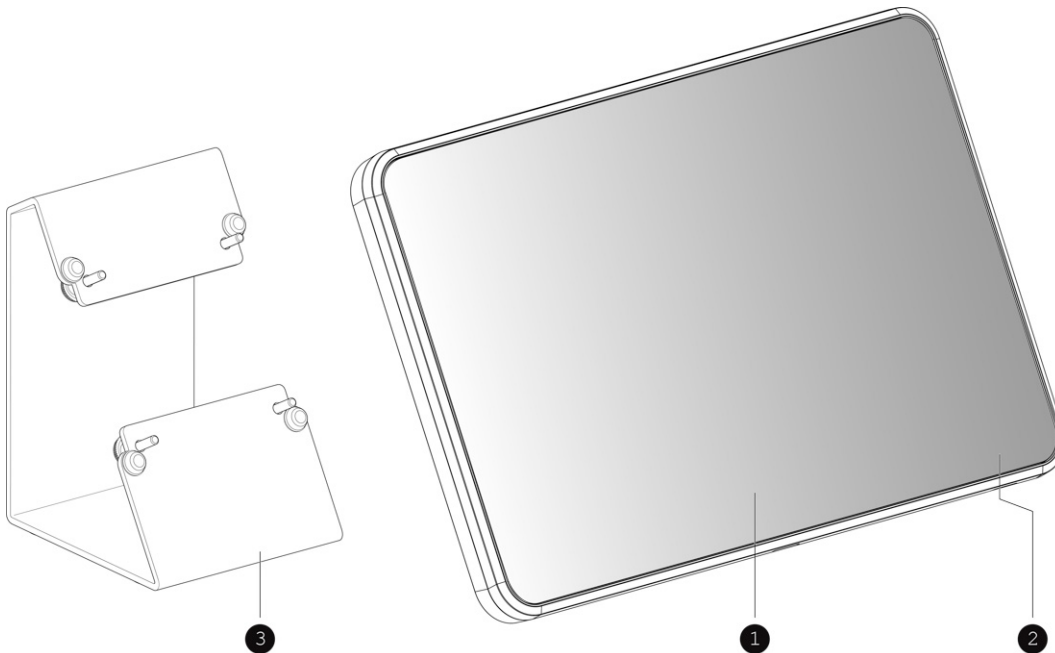

Image 1-1

1. MUIP-2213
2. Power Button:  
Push short to turn the equipment ON/OFF.
3. Desktop support (optional)

## Back

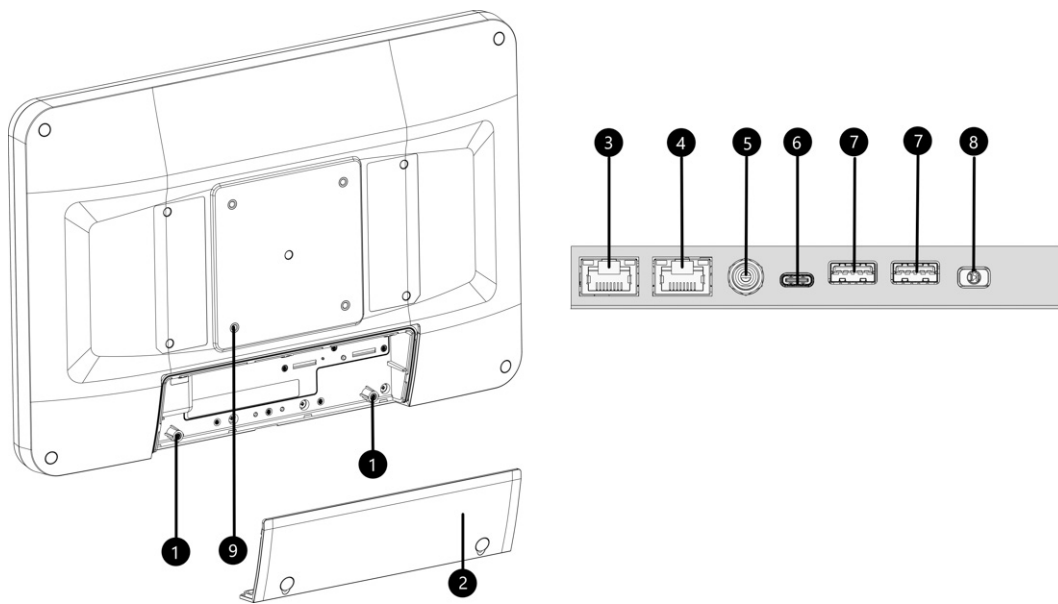

Image 1-2

1. Rear cover fixation screw holes (2x)
2. Cable cover (standard open / optional closed version)
3. Gigabit Ethernet connector (LAN1)
4. Gigabit Ethernet connector (LAN2)
5. Power jack input connector (range 12-24Vdc, nominal 19Vdc)
6. Type C connector (support DP charge, support type C dongle transfer to HDMI out)
7. USB 3.1 port Type A connector (2x)
8. (3-in-1) Audio earphone jack (1x)
9. VESA 75 mm mounting screw holes (4x)

Welcome!

# Installation

# 2



**WARNING:** Read all the important safety information before installing and operating your LCD User Interface. Please refer to the dedicated chapter in this user guide.



**WARNING:** Sufficient expertise is required to install this equipment. All devices and complete setup must be tested before taking into operation.



**CAUTION:** When the display is assembled in the medical system, take care of the fixation of all cables, to avoid unwanted detachment.



**CAUTION:** The equipment is not intended to be sterilized.

## 2.1 Cable connections

### Opening and closing the rear cover

1. Remove the two rubber caps which cover the fixation screws.
2. Remove the two fixation screws and remove the rear cover from the MUIP-2213.

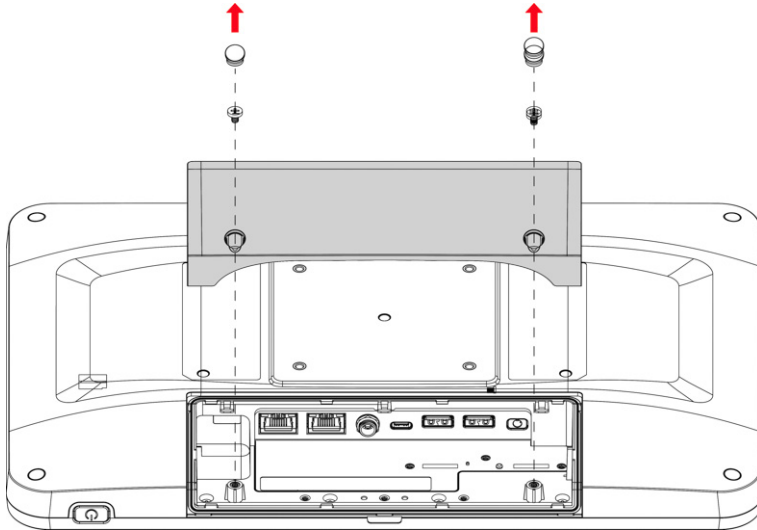

Image 2-1

3. To properly close the rear cover, first route the cables as described in [“Cable routing”](#), page 13. Install the rear cover and follow the above steps in reverse order.

### Power and LAN connection

The MUIP-2213 Computing Touch-Screen Module working as an intelligent User-Interface is usually connected to the system via Ethernet LAN connection and / or USB interface connection.

1. Connect the power connector to the power jack input.

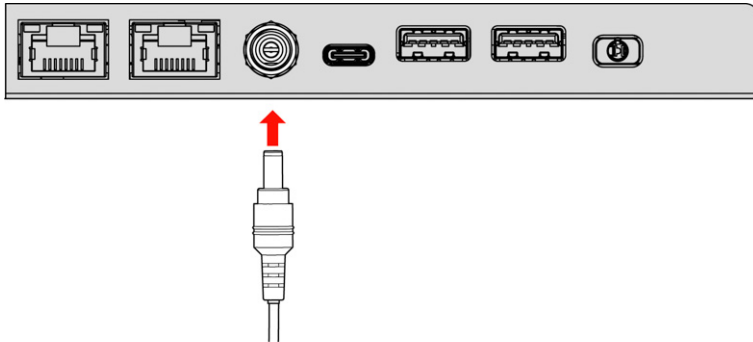

Image 2-2

2. Connect the LAN connector to the LAN input.

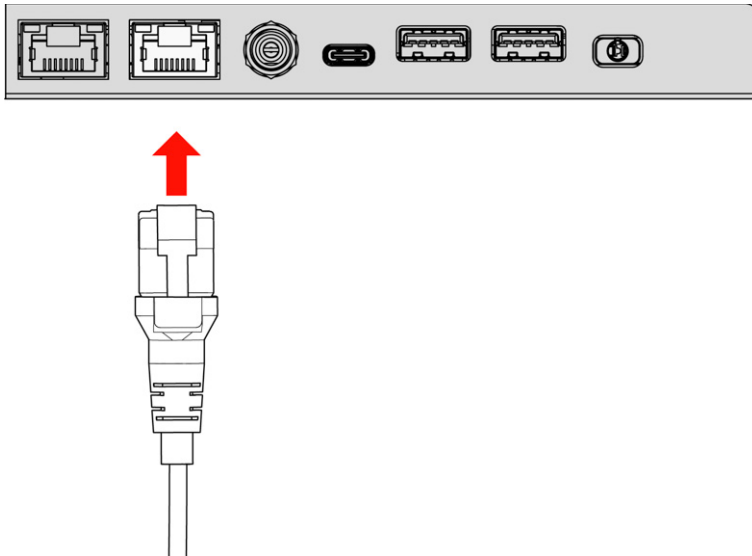

Image 2-3

### Other cable connections example (open rear cover version only)

1. Connect the USB 3.1 connector to the USB 3.1 input.

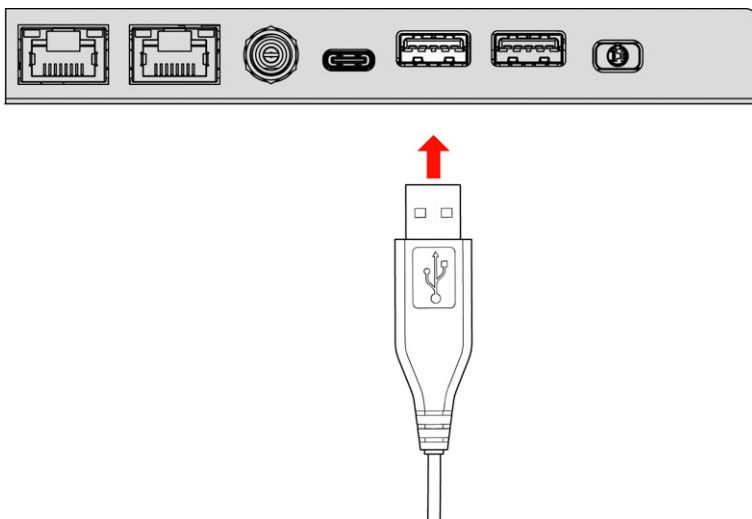

Image 2-4

## 2.2 Cable routing

### Open rear cover version

The cables can be routed in two different ways:

1. Route the cables straight downwards (as shown below).

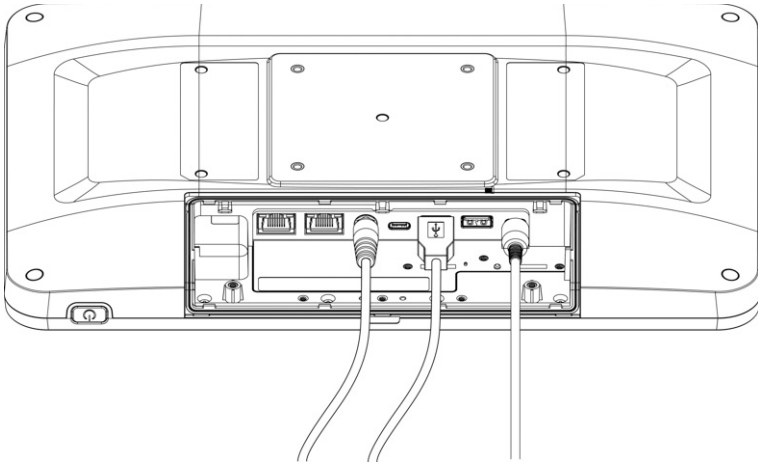

Image 2-5

2. Route the cables behind the pin (as shown below).

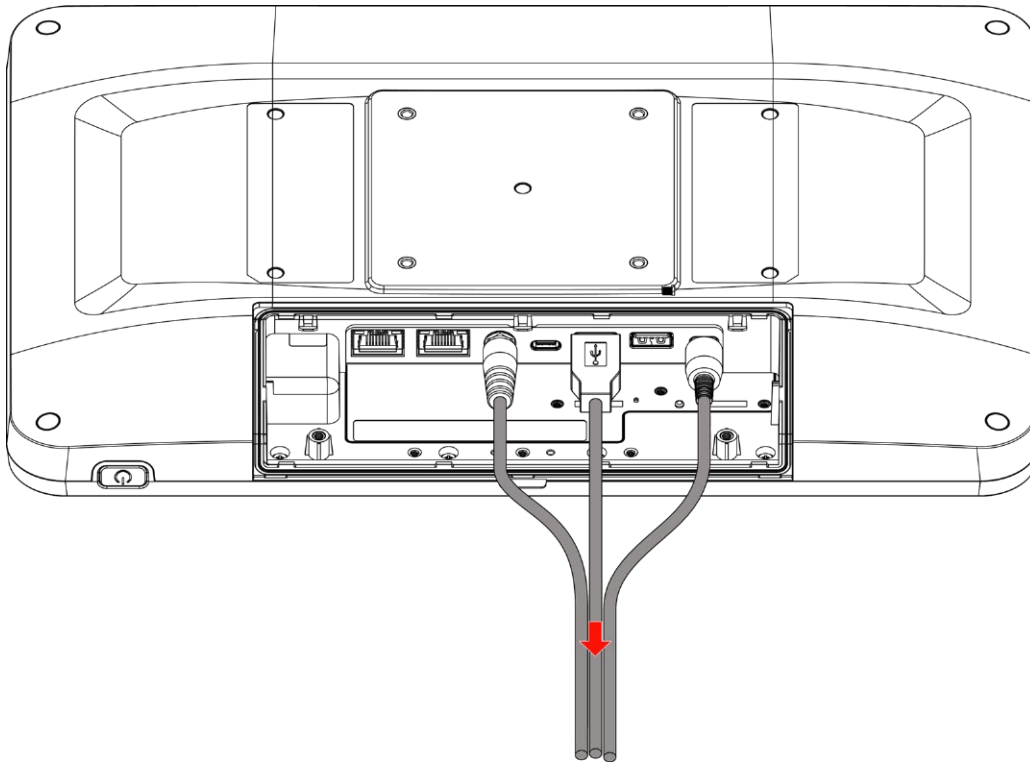

Image 2-6



This routing can only be performed if maximum 3 cables are installed.

### Closed cable cover option

1. The closed cable cover (2) provided hereby, allows routing of all connecting cables through its square hole, instead of routing them straight downwards.

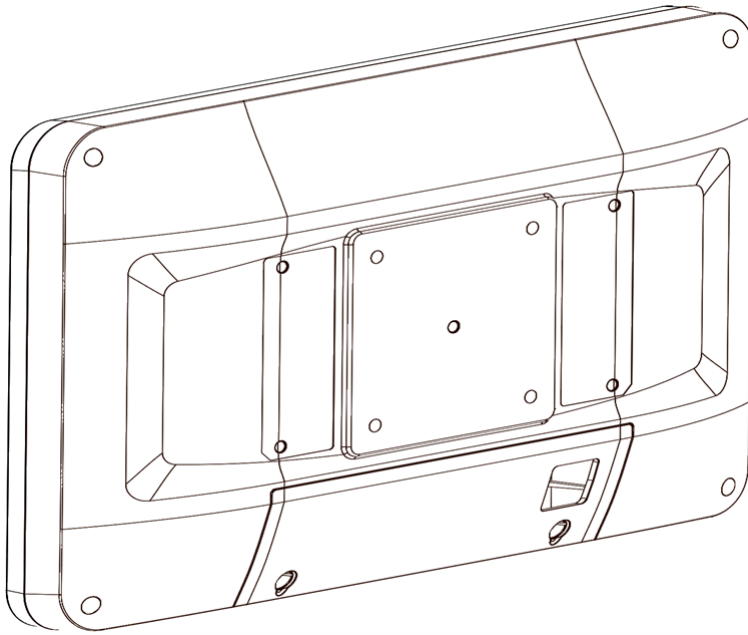

Image 2-7

## 2.3 Desktop support installation (optional)

### Orientation

A desktop support may be included in the MUIP-2213 package. This support can be installed in two different orientations, allowing to achieve a different angle of the display.

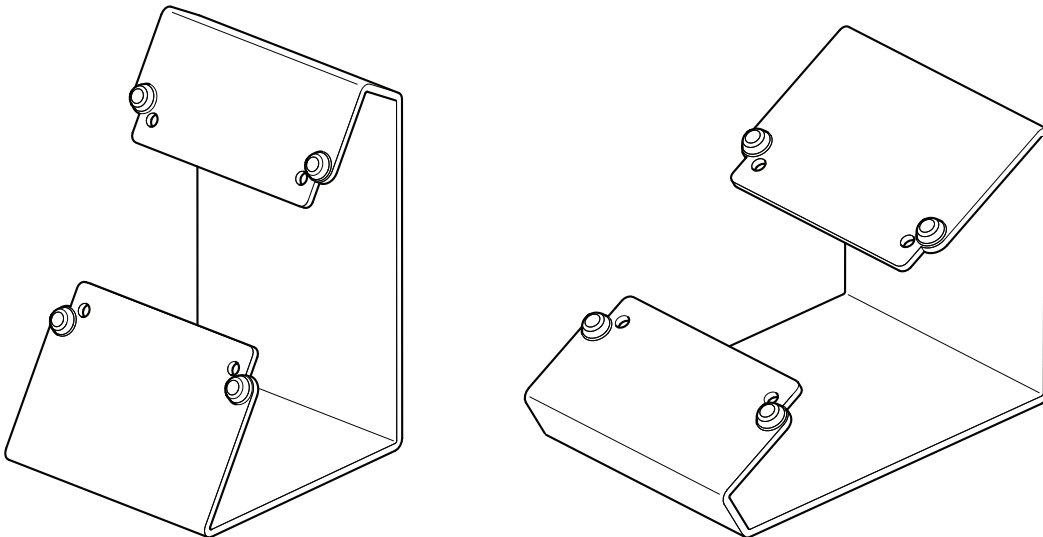

Image 2-8

### Installation

1. Place the desktop support in the desired orientation.
2. Install the MUIP-2213 on the desktop support in landscape orientation.
3. Install and tighten the four VESA 75 mm mounting screws.

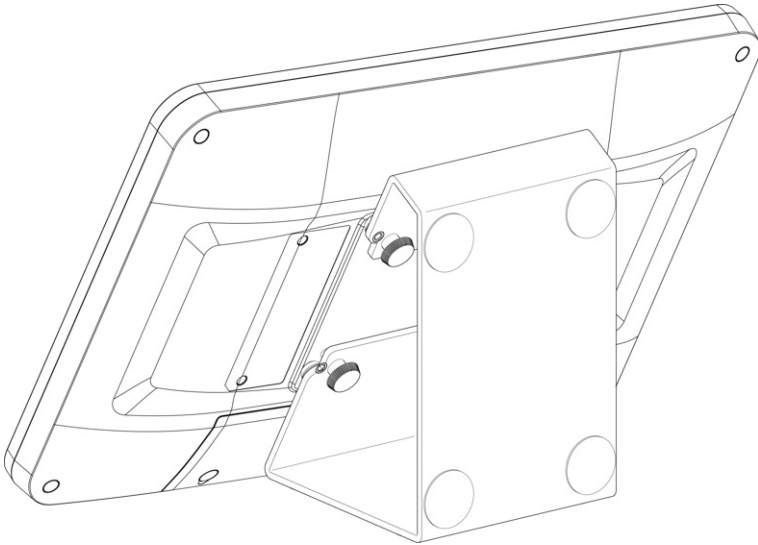

Image 2-9

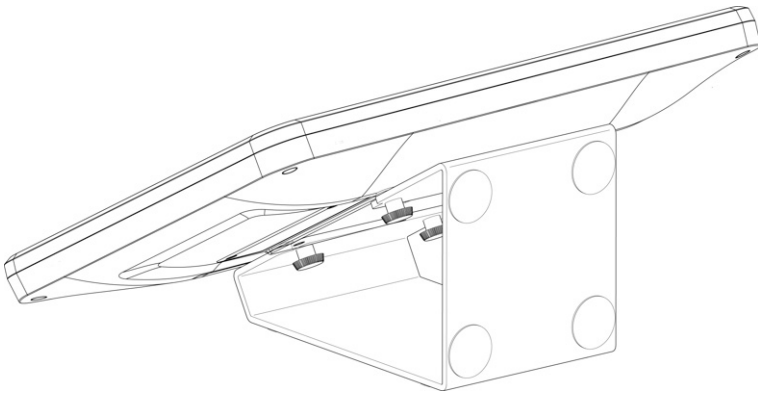

Image 2-10

# Maintenance

# 3

## 3.1 Scheduled maintenance

### About

The MUIP-2213 does not require any scheduled maintenance or calibration activities. In case of inconsistencies, please contact Barco Healthcare.

## 3.2 Cleaning



**WARNING:** Unplug the power cable from the mains power input before cleaning the display.



**CAUTION:** Take care not to damage or scratch the front glass or LCD. Be careful with rings or other jewelry and do not apply excessive pressure on the front glass or LCD.



**CAUTION:** Do not apply or spray liquid directly to the display as excess liquid may cause damage to internal electronics. Instead, apply the liquid to a cleaning cloth.

### To clean the display

Clean the display using a sponge, cleaning cloth or soft tissue, lightly moistened with a recognized cleaning product for medical equipment. Read and follow all label instructions on the cleaning product. In case of doubt about a certain cleaning product, use plain water.

#### Possible cleaning solutions:

- Isopropyl alcohol 90%
- Flux
- Ethanol 70%
- Chlorine 250 ppm in 1-liter distilled water
- Würth, TFT-Reiniger
- Soap with lukewarm water
- 1.6% ammonia
- Sodium hypochlorite 10%
- Peroxide hypochlorite 10%
- Tanet interior

#### Do not use following products:

- Alcohol/solvents at higher concentration > 70%
- Strong alkalis lye, strong solvents
- Acid
- Detergents with fluoride
- Detergents with ammonia at higher concentration > 1.6%
- Detergents with abrasives
- Steel wool
- Sponge with abrasives
- Steel blades
- Cloth with steel thread

**Important  
information**

**4**

## 4.1 Safety information

### General recommendations

Read the safety and operating instructions before operating the device.

Retain safety and operating instructions for future reference.

Adhere to all warnings on the device and in the operating instructions manual.

Follow all instructions for operation and use.

### Electrical shock or fire hazard

To prevent electric shock or fire hazard, do not remove cover.

No serviceable parts inside. Refer servicing to qualified personnel.

Do not expose this apparatus to rain or moisture.

### Modifications to the unit

Do not modify this equipment without authorization of the manufacturer.

### Preventive maintenance

Periodic maintenance inspections are essential to keep the LCD User Interface in optimum condition and ensure safe operation.

With the LCD User Interface disconnected from the mains, perform the following periodic check:

- Check the integrity of the power cord and inspect its routing, so that it is not under the risk of being punched or cut.

General recommendations:

- Keep the LCD User Interface clean to prolong its operational lifetime.
- LCD panel performance may deteriorate in the long term.
- Periodically check that it is correctly operating.
- Periodically check the tightness of the VESA mount screws. If not sufficiently tight, the LCD User Interface may detach from the arm, which may result in injury or equipment damage.

### Type of protection (electrical):

LCD User Interface provided with external power supply: Class II equipment.

LCD User Interface provided without external power supply: Class I or II, depending from the Class of the external power supply used.

### Degree of safety (flammable anesthetic mixture):

Equipment not suitable for use in the presence of a flammable anesthetic mixture with air or with oxygen or nitrous oxide.

The equipment is not operable if the air oxygen content is above 25%.

### Non-patient care equipment

- Equipment primarily for use in a health care facility, including the patient area.
- The equipment should not be used with life support equipment.
- The user should not touch the signal input ports (SIP) / signal output ports (SOP) and the patient at the same time. The rear cover must be kept closed and screwed.

### Child safety

Equipment not suitable for use in locations where children are likely to be present.

## Mission critical applications

We strongly recommend to immediately have a replacement display available in mission critical applications.



## Use of electrical surgical knives

Provide as much distance as possible between the electrosurgical generator and other electronic equipment (such as LCD User Interfaces). An activated electrosurgical generator may cause interference with this equipment and can disrupt the functionality of the display.

## Power connection (the configuration without power supply)

- Power requirements: The equipment must be powered using medical approved AC/DC power supply.
- The medical approved AC/DC power supply must be powered by the AC mains voltage.
- The equipment should be installed near an easily accessible wall socket.
- To disconnect the main power, unplug the AC adapter.
- The equipment is intended for continuous operation.
- The compliance of the equipment with the Medical Safety and EMC requirements has been evaluated with the provided medical grade power supply. If a different power supply is used, further investigation for Safety and EMC requirements have to be performed at system level.
- Do not use the supplied AC adapter for powering other devices.
- Do not move the equipment while the power cord and connection cables are connected. Otherwise, damage to the equipment, power cord and connection cables, fire or an electric shock may result.

## Power connection – Equipment with external 19V VDC power supply

- Power requirements: The equipment must only be powered using the delivered medical approved 12-24 VDC (  ) SELV power supply.
- The medical approved DC (  ) power supply must be powered by the AC mains voltage.
- The power supply is specified as a part of the equipment.
- To avoid the risk of electric shock, this equipment must only be connected to a supply mains with protective earth.
- The equipment should be installed near an easily accessible outlet.
- The equipment is intended for continuous operation.
- The compliance of this LCD User Interface with Medical Safety and EMC requirements has been evaluated using the external (optional) medical power supply model 'TR60M19'. If a different power supply will be used, further investigation for safety and EMC requirements have to be performed at system level.

## Transient over-voltage

To fully disengage the power from the device, please disconnect the power cord from the AC inlet.

## Connections

Any external connection with other peripherals must follow the requirements of clause 16 of IEC60601-1 3rd. Ed. for the medical electrical systems.

To maintain compliance with EMC Regulation, use only shielded interface cables for the connection to peripheral devices.

## Power cords:

- Please use the power cord provided with this equipment. If a power cord is not supplied with this equipment, please contact your supplier. For all other cases, please use a power cord that matches the AC voltage of the power outlet and has been approved by and complies with the safety standard of your particular country.
- Do not overload wall sockets and extension cords as this may result in fire or electric shock.
- Mains lead protection: Power cords should be routed so that they are not likely to be walked upon or pinched by items placed upon or against them, paying particular attention to cords at plugs and receptacles.
- The power supply cord should be replaced by the designated operator only, at all times.

## Liquids and moisture

Never expose the equipment to liquids or moisture.

Never use the equipment near water - e.g. near a bathtub, washbasin, swimming pool, kitchen sink, laundry tub or in a wet basement.

To check the IP rate, please refer to the product label or the specifications table.

The power supply is IPx0 (when provided).

## Moisture condensation

Do not use the equipment under rapidly changing temperature and humidity conditions or avoid direct contact with cold air from air-conditioning outlet.

Moisture may condense on the surface or inside of the equipment, or create a mist residue inside the protection plate. This is not a malfunction of the product itself, although it may cause damage to the equipment.

If condensation exists, leave the equipment unplugged until there is no condensation.

## Ventilation

When installing the device in a cupboard or another enclosed location, heed the necessary space between the set and the sides of the cupboard.

The LCD panel becomes warm during operation. This is not a malfunction. Allow adequate air circulation to reduce the temperature of the equipment.

## Installation

- Place the equipment on a flat, solid and stable surface that can support the weight of at least 3 units. If you use an unstable cart or stand, the equipment may fall, causing serious injury to a child or adult and/or serious damage to the equipment.
- Do not allow to climb or rest on the equipment.
- When the equipment is attached to an arm, do not use the equipment as a handle or grip in order to move the equipment. Please refer to the instruction manual of the arm for instructions on how to move the arm with the equipment.
- Provide full attention to safety during installation, periodic maintenance and examination of this equipment.
- Sufficient expertise is required for installing this equipment, especially to determine the strength of the wall, arm or ceiling suspension for withstanding the display's weight. Be sure to entrust the attachment of this equipment to the wall to a duly skilled technician and pay adequate attention to safety during the installation and usage.
- The manufacturer is not liable for any damage or injury caused by mishandling or improper installation.
- When the display is assembled in the medical system, take care of unwanted detachment.
- The equipment should be installed near an easily accessible place. Do not install or leave the unit in places subject to extreme temperatures, near a radiator, heating vent, or in places subject to mechanical vibration or shock. Subjecting the LCD display to extreme temperatures, could cause deformations of the casing or malfunctions.
- Avoid placing the unit near any equipment that generates a strong electro-magnetic field, such as surgical knives or other medical appliances.
- Avoid places subject to inordinate amounts of dust, dirt, or sand, for example near an open window or an outdoor exit.
- If setting up temporarily in an outdoor environment, be sure to take adequate precautions against airborne dust and dirt. Otherwise unrecoverable malfunctions could occur.

## Handling

Do not press on or scratch the front protection screen. Do not place a heavy object on the equipment.

If the equipment is used in a cold place, a residual image may appear in the screen. This is not a malfunction. The screen returns to normal as the temperature rises to a normal operating level.

If a still picture is displayed for a long time, a residual image may appear for a while. The residual image will eventually disappear.

## Transportation

Disconnect the cable from the equipment when transporting.

When you transport the equipment, hold it firmly in both hands. If you drop the equipment, you may be injured or the equipment may be damaged.

When you transport the equipment for repair or shipment, use the original cardboard box and packing materials.

## Batteries

- This device uses an RTC battery (Mod. CR-2032) and a Lithium Ion battery pack (Mod. RRC2130).
- RTC battery (Mod. CR-2032), normal voltage: 3V. Normal capacity: 220mAh.
- Lithium Ion battery pack (Mod. RRC2130), normal voltage: 7.2V. Normal capacity: 4.17Ah.
- Both batteries are not user-replaceable. Do not attempt to replace them, contact Barco authorized repair facilities
- Batteries used with this equipment have been tested for compatibility and should only be replaced with approved parts.
- The batteries are not designed to be charged by any other electrical source. Charging could generate gas and internal short-circuiting, leading to distortion, leakage, overheating, explosion, or fire.

## Connection of PEMS by network/data coupling to other equipment

- Connection of the PEMS to a network/data coupling that includes other equipment could result in previously unidentified risks to patients, operators or third parties.
- The responsible organization should identify, analyze, evaluate and control these risks.
- Subsequent changes to the network/data coupling could introduce new RISKS and require additional analysis.
- Changes to the NETWORK/DATA COUPLING include:
  - Changes in NETWORK/DATA COUPLING configuration;
  - Connection of additional items to the NETWORK/DATA COUPLING;
  - Disconnecting items from the NETWORK/DATA COUPLING;
  - Update of equipment connected to the NETWORK/DATA COUPLING;
  - Upgrade of equipment connected to the NETWORK/DATA COUPLING.

## Malfunctions

Disconnect the equipment's power cord from the AC inlet and refer servicing to qualified service technicians under the following conditions:

- If the power cord or plug is damaged or frayed.
- If liquid has been spilled into the equipment.
- If the equipment has been exposed to rain or water.
- If the equipment does not operate normally when the operating instructions are followed. Adjust only those controls that are covered by the operating instructions since improper adjustment of other controls may result in damage and will often require extensive work by a qualified technician to restore the product to normal operation.
- If the equipment has been dropped or the cabinet has been damaged.
- If the product exhibits a distinct change in performance, indicating a need for service.

## General warnings

- All devices and complete setup must be tested and validated before taking into operation.
- At end user application level, it is necessary to foresee a backup unit in case the equipment fails.
- The enclosure has to be checked upon collision damage; refer to qualified service personnel.
- The LCD User Interface is intended for indoor use.
- The LCD User Interface is not intended to be sterilized.
- The LCD User Interface has not applied parts, but the front side of the LCD panel and the plastic enclosure have been treated as applied part because considered accidentally touchable by the patient for a time  $\leq 1$  minute.
- Do not connect to the internet before you have installed an anti-virus software and Internet firewall to protect the Barco User Interface from viruses.

## National Scandinavian Deviations for CL. 1.7.2

Finland: "Laite on liitettävä suojamaadoituskoskettimilla varustettuun pistorasiaan"

Norway: "Apparatet må tilkoples jordet stikkontakt"

Sweden: "Apparaten skall anslutas till jordat uttag"



**CAUTION:** If the MUIP-2213 is integrated as component in a medical-equipment providing life-support, the user-integrator shall provide the necessary precautions to avoid possible damage, injury or harm to the patients. The MUIP-2213 has no essential performances and the provided Windows OS is not a class-A software.



**CAUTION:** The enclosure has to be checked upon collision damage, refer to qualified service personnel.

## 4.2 Cybersecurity

### Hospital IT security

To prevent unauthorized access to the device, the organization incorporating the MUIP-2213 in their IT network shall have the necessary state-of-the-art policies, processes, standards and other security measures in place to incorporate, support and protect the device into the IT network. This shall include the application of risk management (e.g. by following IEC 80001-1:2010 or equivalent standards).

To ensure optimal security of your device, we strongly recommend following these essential cybersecurity measures:

- Upon initial logon, change the password for the service account. This helps mitigate potential vulnerabilities and unauthorized access to your system.
- Enable the TPM feature (in the BIOS) of your device. TPM provides hardware-based security capabilities, such as cryptographic key generation and storage, that significantly enhance the protection of sensitive data.
- Activate the BitLocker encryption feature, which safeguards your data by encrypting the entire hard drive. BitLocker prevents unauthorized access to data in case of theft or unauthorized physical access to the device.
- Activate the Secure Boot or Device Guard feature, when feasible, to ensure that only trusted and verified software is loaded during the system boot process. This helps defend against malware and unauthorized software tampering.

Implementing these measures significantly reduces cybersecurity risks and enhances the overall security posture of your system. By adhering to these guidelines, you can better protect your data, maintain the integrity of your system, and mitigate potential threats.

## 4.3 Environmental information

### Disposal Information



Waste Electrical and Electronic Equipment (WEEE)

This symbol on the product indicates that, under the European Directive 2012/19/EU governing waste from electrical and electronic equipment, this product must not be disposed of with other municipal waste. Please dispose of your waste equipment by handing it over to a designated collection point for the recycling of waste electrical and electronic equipment. To prevent possible harm to the environment or human health from uncontrolled waste disposal, please separate these items from other types of waste and recycle them responsibly to promote the sustainable reuse of material resources.

For more information about recycling of this product, please contact your local city office or your municipal waste disposal service. For details, please visit the Barco website at: <https://www.barco.com/about/sustainability/waste-of-electronic-equipment-customers>

## Turkey RoHS compliance



Türkiye Cumhuriyeti: AEEE Yönetmeliğine Uygundur.  
[Republic of Turkey: In conformity with the WEEE Regulation]

## Recycling

Recycle batteries according to national and local regulations.

Contact your local representative for assistance.

The batteries must be disposed only in a discharged state at the collection center.

In case of not fully discharged batteries, provide for a risk against short circuits.

Short circuits can be prevented by isolating the terminals with tape.

## 中国大陆 RoHS

Chinese Mainland RoHS

根据中国大陆《电器电子产品有害物质限制使用管理办法》（也称为中国大陆RoHS），以下部分列出了Barco产品中可能包含的有毒和/或有害物质的名称和含量。中国大陆RoHS指令包含在中国信息产业部MCV标准：“电子信息产品中有毒物质的限量要求”中。

According to the “Management Methods for the Restriction of the Use of Hazardous Substances in Electrical and Electronic Products ” (Also called RoHS of Chinese Mainland), the table below lists the names and contents of toxic and/or hazardous substances that Barco’s product may contain. The RoHS of Chinese Mainland is included in the MCV standard of the Ministry of Information Industry of China, in the section “Limit Requirements of toxic substances in Electronic Information Products”.

零件项目(名称) Component name	有毒有害物质或元素 Hazardous substances and elements					
	铅 Pb	汞 Hg	镉 Cd	六价铬 Cr6+	多溴联苯 PBB	多溴二苯醚 PBDE
印制电路配件 Printed Circuit Assemblies	X	O	O	O	O	O
液晶面板 LCD panel	X	O	O	O	O	O
外接电(线)缆 External Cables	X	O	O	O	O	O
内部线路 Internal wiring	O	O	O	O	O	O
金属外壳 Metal enclosure	O	O	O	O	O	O
塑胶外壳 Plastic enclosure	O	O	O	O	O	O
散热片(器) Heatsinks	O	O	O	O	O	O
锂金属电池 Battery	O	O	O	O	O	O
电源供应器 Power Supply Unit	X	O	O	O	O	O
文件说明书 Paper Manuals	O	O	O	O	O	O

零件项目(名称) Component name	有毒有害物质或元素 Hazardous substances and elements					
	铅 Pb	汞 Hg	镉 Cd	六价铬 Cr6+	多溴联苯 PBB	多溴二苯醚 PBDE
光盘说明书 CD manual	○	○	○	○	○	○
本表格依据SJ/T 11364的规定编制 This table is prepared in accordance with the provisions of SJ/T 11364. ○: 表示该有毒有害物质在该部件所有均质材料中的含量均在 GB/T 26572 标准规定的限量要求以下。 ○: Indicates that this toxic or hazardous substance contained in all of the homogeneous materials for this part is below the limit requirement in GB/T 26572. X: 表示该有毒有害物质至少在该部件的某一均质材料中的含量超出 GB/T 26572 标准规定的限量要求。 X: Indicates that this toxic or hazardous substance contained in at least one of the homogeneous materials used for this part is above the limit requirement in GB/T 26572.						

在中国大陆销售的相应电子信息产品（EIP）都必须遵照中国大陆《电子电气产品有害物质限制使用标识要求》标准贴上环保使用期限（EFUP）标签。Barco产品所采用的EFUP标签（请参阅实例，徽标内部的编号用于指定产品）基于中国大陆的《电子信息产品环保使用期限通则》标准。

All Electronic Information Products (EIP) that are sold within Chinese Mainland must comply with the “Marking for the restriction of the use of hazardous substances in electrical and electronic product” of Chinese Mainland, marked with the Environmental Friendly Use Period (EFUP) logo. The number inside the EFUP logo that Barco uses (please refer to the photo) is based on the “General guidelines of environment-friendly use period of electronic information products” of Chinese Mainland.



## 中国RoHS自我声明符合性标志 / China RoHS – SDoC mark

本产品符合《电器电子产品有害物质限制使用管理办法》和《电器电子产品有害物质限制使用达标管理目录》的要求。

This product meets the requirements of the “Management Rule on the Use Restriction of Hazardous Substances in Electrical and Electronic Products” and the “Management Catalogue for the Use Restriction of Hazardous Substances in Electrical and Electronic Products”.



绿色自我声明符合性标志可参见电子档文件

The green SDoC mark is visible in the digital version of this document.

## RoHS

Directive 2011/65/EC on the restriction of certain hazardous substances in electrical and electronic equipment.

According to what declared by our components suppliers, this products is RoHS compliant.

## 4.4 Biological hazard and returns – Decommissioning

### Decommissioning

When a device becomes obsolete or unusable, or is no longer needed by the health care facility, it enters the final stage of its life cycle: decommissioning.

Decommissioning is the process of disposing a device, or removing a device from its originally intended use in the health care facility to an alternative use.

Every health care facility or institution shall have standard operating procedures in place to decommission a device according to the Occupational Safety and Health Administration (OSHA) regulations or/and the World Health Organization (WHO) Decommissioning Medical Devices Technical guideline.

The seller / manufacturer of the device has no legal obligation on the device sold in the event that the health care facility or institution decides to activate the decommissioning process.

## Overview

The structure and the specifications of this device as well as the materials used for manufacturing makes it easy to wipe and clean and therefore suitable to be used for various applications in hospitals and other medical environments, where procedures for frequent cleaning are specified.

However, normal use shall exclude biological contaminated environments, to prevent spreading of infections.

Therefore use of this device in such environments is at the exclusive risk of Customer. In case this device is used where potential biological contamination cannot be excluded.

Customer shall implement the decontamination process as defined in the latest edition of the ANSI/AAMI ST35 standard on each single failed Product that is returned for servicing, repair, reworking or failure investigation to Seller (or to the Authorized Service Provider). At least one adhesive yellow label shall be attached on the top site of the package of returned Product and accompanied by a declaration statement proving the Product has been successfully decontaminated.

Returned Products that are not provided with such external decontamination label, and/or whenever such declaration is missing, can be rejected by Seller (or by the Authorized Service Provider) and shipped back at Customer expenses.

## 4.5 Regulatory information

### Intended Purpose

MUIP-2213 is a LCD user interface for use in the hospital environment. It can be used for third party software applications that provide a user interface for medical systems. The equipment can be used in CathLab Examination Rooms & Control Rooms, Surgical Rooms and Hybrid Operating Rooms, both inside and outside the patient area. The equipment is not intended to be used for displaying medical images, nor for diagnostic purposes.

### Factory address

**BARCO S.R.L.**, Via Saul Banfi 1, 21047 Saronno, VA, Italy

### Manufacturing country

The manufacturing country of the product is indicated on the product label (“**Made in ...**”).

### Importers contact information

To find your local importer, contact one of Barco’s regional offices via the contact information provided on our website ([www.barco.com](http://www.barco.com)).

### FCC class B

This device complies with Part 15 of the FCC Rules. Operation is subject to the following two conditions: (1) this device may not cause harmful interference, and (2) this device must accept any interference received, including interference that may cause undesired operation.

This device has been tested and found to comply with the limits for a Class B digital device, pursuant to Part 15 of the FCC Rules. These limits are designed to provide reasonable protection against harmful interference in a residential installation. This device generates, uses and can radiate radio frequency energy and, if not installed and used in accordance with the instructions, may cause harmful interference to radio communications. However, there is no guarantee that interference will not occur in a particular installation. If this device does cause harmful interference to radio or television reception, which can be determined by

turning the device off and on, the user is encouraged to try to correct the interference by one or more of the following measures:

- Reorient or relocate the receiving antenna.
- Increase the separation between the device and receiver.
- Connect the device into an outlet on a circuit different from that to which the receiver is connected.
- Consult the dealer or an experienced radio/TV technician for help.

Changes or modifications not expressly approved by the party responsible for compliance could void the user's authority to operate the equipment.

**FCC responsible:** Barco Inc., 3059 Premiere Parkway Suite 400, 30097 Duluth GA, United States, Tel: +1 678 475 8000

### Canadian notice

CAN ICES-003 (B) / NMB-003(B)

### UKCA compliance

Authorised representative in the UK: Barco UK Ltd, Building 329, Doncastle Road, Bracknell RG12 8PE, Berkshire, United Kingdom

## 4.6 EMC notice

### General information

This device is suitable for use in healthcare facility environments.

With the installation of the device, use only the delivered external cables and power supply or a spare part provided by the legal manufacturer. Using another can result in a decrease of the immunity level of the device.



**WARNING:** Use of this equipment adjacent to or stacked with other equipment should be avoided because it could result in improper operation. If such use is necessary, this equipment and the other equipment should be observed to verify that they are operating normally.



**WARNING:** Use of accessories, transducers and cables other than those specified or provided by the manufacturer of this equipment could result in increased electromagnetic emissions or decreased electromagnetic immunity of this equipment and result in improper operation.



**WARNING:** Portable RF communications equipment (including peripherals such as antenna cables and external antennas) should be used no closer than 30 cm (12 inches) to any part of the MUIP-2213, including cables specified by the manufacturer. Otherwise, degradation of the performance of this equipment could result.

### Electromagnetic emissions

The MUIP-2213 is suitable for use in the electromagnetic environment specified below. The customer or the user of the MUIP-2213 should assure that it is used in such an environment.

Emissions test	Compliance	Electromagnetic environment – Guidance
RF emissions CISPR 11	Group 1	The MUIP-2213 uses RF energy only for its internal function. Therefore, its RF emissions are very low and are not likely to cause any interference in nearby electronic equipment.
RF emissions CISPR 11	Class B	The MUIP-2213 is suitable for use in all establishments, including domestic establishments and those

<b>Emissions test</b>	<b>Compliance</b>	<b>Electromagnetic environment – Guidance</b>
Harmonic emissions IEC 61000-3-2	Class D <sup>1</sup>	directly connected to the public low-voltage power supply network that supplies buildings used for domestic purposes.
Voltage fluctuations/ flicker emissions IEC 61000-3-3	Complies	

This MUIP-2213 complies with appropriate medical EMC standards on emissions to, and interference from surrounding equipment. Operation is subject to the following two conditions: (1) this device may not cause harmful interference, and (2) this device must accept any interference received, including interference that may cause undesired operation.

Interference can be determined by turning the equipment off and on.

If this equipment does cause harmful interference to, or suffer from harmful interference of, surrounding equipment, the user is encouraged to try to correct the interference by one or more of the following measures:

- Reorient or relocate the receiving antenna or equipment.
- Increase the separation between the equipment and receiver.
- Connect the equipment into an outlet on a circuit different from that to which the receiver is connected.
- Consult the dealer or an experienced technician for help.

## Electromagnetic immunity

The MUIP-2213 is tested to be used in the electromagnetic environment specified below. The customer or the user of the MUIP-2213 should assure that it is not used in an environment that exceeds the listed test levels and limits.

<b>Immunity test</b>	<b>IEC 60601 test levels</b>	<b>Compliance level</b>	<b>Electromagnetic environment – guidance</b>
Electrostatic discharge (ESD) IEC 61000-4-2	± 8 kV contact ± 2 kV, ± 4 kV, ± 8 kV, ± 15 kV air	± 8 kV contact ± 2 kV, ± 4 kV, ± 8 kV, ± 15 kV air	Floors should be wood, concrete or ceramic tile. If floors are covered with synthetic material, the relative humidity should be at least 30%
Electrical fast transient/ burst IEC 61000-4-4	± 2 kV for power supply lines ± 1 kV for input/ output lines 100 kHz repetition frequency	± 2 kV for power supply lines ± 1 kV for input/ output lines 100 kHz repetition frequency	Mains power quality should be that of a typical commercial or hospital environment
Surge IEC 61000-4-5	Line to line: ± 0.5 kV, ± 1 kV Line to ground: ± 0.5 kV, ± 1 kV, ± 2 kV	Line to line: ± 0.5 kV, ± 1 kV Line to ground: ± 0.5 kV, ± 1 kV, ± 2 kV	Mains power quality should be that of a typical commercial or hospital environment
Voltage dips, short interruptions and voltage variations on power supply input lines IEC 61000-4-11	0% residual voltage for 0.5 period at 0°, 45°, 90°, 135°, 180°, 225°, 270° and 315° 0% residual voltage for 1 period at 0° 70% residual voltage for 25 periods at 0° Voltage interruptions: 0% residual voltage for 250 periods at 0°	0% residual voltage for 0.5 period at 0°, 45°, 90°, 135°, 180°, 225°, 270° and 315° 0% residual voltage for 1 period at 0° 70% residual voltage for 25 periods at 0° Voltage interruptions: 0% residual voltage for 250 periods at 0°	Mains power quality should be that of a typical commercial or hospital environment. If the user of the MUIP-2213 requires continued operation during power mains interruptions, it is recommended that the MUIP-2213 be powered from an uninterruptible power supply or a battery

1. Active power for MUIP-2213 is less than 75 W

Immunity test	IEC 60601 test levels	Compliance level	Electromagnetic environment – guidance
Power frequency (50/60 Hz) magnetic field IEC 61000-4-8	30 A/m	30 A/m	Power frequency magnetic fields should be at levels characteristic of a typical location in a typical commercial or hospital environment
Conducted RF IEC 61000-4-6	3 Vrms (6 Vrms in ISM bands) 150 kHz to 80 MHz	3 Vrms (6 Vrms in ISM bands)	If there is a mark on the device as shown on the right  , interference may occur.
Radiated RF IEC 61000-4-3 IEC 61000-4-39	3 V/m 80 MHz to 2.7 GHz	3 V/m	
	8 A/m @ 30kHz (CW) 65 A/m @ 134.2 kHz (2.1 kHz Pulse modulation) 7.5 A/m @ 13.56 MHz (50 kHz Pulse modulation)	8 A/m @ 30kHz (CW) 65 A/m @ 134.2 kHz (2.1 kHz Pulse modulation) 7.5 A/m @ 13.56 MHz (50 kHz Pulse modulation)	-













### Immunity to RF wireless communications equipment













Test frequency (MHz)	Band (MHz)	Service	Modulation	Maximum power (W)	Distance (m)	Immunity test level (V/m)
385	380 – 390	TETRA 400	Pulse modulation 18 Hz	1.8	0.3	27
450	430 – 470	GMRS 460, FRS 460	FM ± 5 kHz deviation 1 kHz sine	2	0.3	28
710	704 – 787	LTE Band 13, 17	Pulse modulation 217 Hz	0.2	0.3	9
745						
780						
810	800 – 960	GSM 800/ 900, TETRA 800, iDEN 820, CDMA 850, LTE Band 5	Pulse modulation 18 Hz	2	0.3	28
870						
930						
1720	1700 – 1990	GSM 1800, CDMA 1900, GSM 1900, DECT, LTE Band 1/3/4/ 25, UMTS	Pulse modulation 217 Hz	2	0.3	28
1845						
1970						
2450	2400 – 2570	Bluetooth, WLAN, 802.11 b/g/n, RFID 2450, LTE Band 7	Pulse modulation 217 Hz	2	0.3	28
5240	5100 – 5800	WLAN 802.11 a/n	Pulse modulation 217 Hz	0.2	0.3	9
5500						
5785						

## 4.7 Explanation of symbols



### Symbols on the device

On the device or power supply, you may find the following symbols (nonrestrictive list):

	Indicates the device meets the requirements of the applicable EC directives/regulations.
	Indicates compliance with Part 15 of the FCC rules (Class A or Class B)
	Indicates the device is approved according to the UL Recognition regulations
	Indicates the device is approved according to the UL regulations for Canada and US
	Indicates the device is approved according to the UL Demko regulations
	Indicates the device is approved according to the CCC regulations
	Indicates the device is approved according to the VCCI regulations
	Indicates the device is approved according to the KC regulations
	Indicates the device is approved according to the BSMI regulations
	Indicates the device is approved according to the PSE regulations
	Indicates the device is approved according to the RCM regulations
	Indicates the device is approved according to the EAC regulations





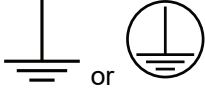

<p>IS 13252 (Part 1) IEC 60950-1</p>  <p>R-xxxxxxx www.bis.gov.in</p>	<p>Indicates the device is approved according to the BIS regulations</p>
 <p>INMETRO</p>	<p>Indicates the device is approved according to the INMETRO regulations.</p>
	<p>Indicates the device is approved according to the UKCA regulations.</p>
	<p>Indicates the USB connectors on the device</p>
	<p>Indicates the DisplayPort connectors on the device</p>
	<p>Indicates the entity importing the device into the locale.</p>
	<p>Indicates the temperature limitations<sup>2</sup> for the device to safely operate within specs.</p>
<p>SN</p>	<p>Indicates the device serial number</p>
<p>REF</p>	<p>Indicates the device part number or catalogue number</p>
	<p><b>Warning:</b> dangerous voltage</p>
	<p><b>Caution</b></p>
	<p>Please carefully read and follow the instructions and warnings on the label to ensure safe use.</p>
	<p>Consult the Instructions For Use</p>
 <p>eIFU indicator</p>	<p>Consult instruction for use on website address that is provided as eIFU indicator</p>
	<p>Indicates this device must not be thrown in the trash but must be recycled, according to the European WEEE (Waste Electrical and Electronic Equipment) directive</p>

2. Values for xx and yy can be found in the technical specifications paragraph.

	Indicates Direct Current (DC)
	Indicates Alternating Current (AC)
	Stand-by
	Protective earth (ground)

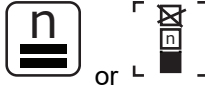
## Symbols on the box

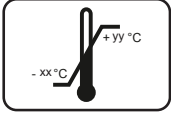
On the box of the device, you may find the following symbols (nonrestrictive list):

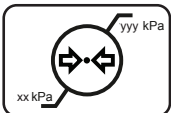
	Indicates a device that can be broken or damaged if not handled carefully when being stored.
	Indicates a device that needs to be protected from moisture when being stored.
	Indicates the storage direction of the box. The box must be transported, handled and stored in such a way that the arrows always point upwards.
	Indicates the maximum number of identical boxes which may be stacked on each other, where “n” is the limiting number.
	Indicates the weight of the box and that it should be carried with two persons.
	Indicates that the box should not be cut with a knife, a cutter or any other sharp object.
	Indicates the temperature limits <sup>3</sup> to which the device can be safely exposed when being stored.
	Indicates the range <sup>3</sup> of humidity to which the device can be safely exposed when being stored.
	Indicates the range <sup>3</sup> of atmospheric pressure to which the device can be safely exposed when being stored.

3. Values for xx and yy can be found in the technical specifications paragraph.

## 4.8 Technical specifications

Description	Configuration for MUIP-2213 STEW BNN1, MUIP-2213 STEW-BNN2, MUIP-2213 STEW-BNN3, MUIP-2213 STEW-BNN6
Processor (SoC)	Intel® Pentium® N6415, Quad core @1.2GHz, 1.5 MB L2 Cache
BIOS	INSYDE
Operating system	Microsoft Windows 10 IoT LTSC / 11 IoT LTSC
Networking	Built-in Gigabit Ethernet LAN interfaces (2 ports)
Memory	8 GB DDR4 3200MHz RAM (module)
Local storage	128 GB M.2, PCIE module
LCD panel characteristics	13.3" TFT LCD 1920 x 1080 pixels resolution
Audio system	1x (3-in-1) audio earphone jack
USB	2 x USB 3.1 type A port 1 x USB 3.1 type C port under the rear cable cover
Buttons and controls	Power button on bottom-right side
Input device	Touchscreen multi-touch (PCAP technology)
Power source input	19 Vdc
Internal battery for MUIP-2213 STEW BNN1	4170 mAh / 7.2 Vdc (not removable) avoids UI crash in case of mains power drop
Protection against electrical shocks	Class II
Power supply	External AC-DC power supply
Operating temperature (for safety)	10 °C to 35 °C
Operating temperature (for performance)	10 °C to 35 °C
Operating humidity	20% to 80% for performance 10% to 90% for safety (non-condensing)
Storage temperature	-20 °C to 50 °C
Storage humidity	10% to 90% (non-condensing)
Storage altitude	70 to 110 kPa
Operating altitude	3000 m (Max)
Ingress protection	IPX3
Durability	Rugged anti-shock design
Weight	1.86 kg (typical) without desktop support 2.21 kg (typical) with desktop support
Dimensions (W x H x D)	334 x 226 x 38 mm

<b>Certifications &amp; compliance</b>	China: CCC Europe: CE (ITE), DEMKO US and Canada: UL, FCC, ICES-003 Japan: VCCI Australia: RCM India: BIS
<b>Standards</b>	AAMI ES60601-1:2005, ES60601-1:2005/AMD1:2012, ES60601-1:2005/AMD2:2021 CAN/CSA-C22.2 NO. 60601- 1:14/A2:2022 IEC 60601-1:2005, AMD1:2012, AMD2:2020 EN 60601-1:2006/A1:2013/A12:2014/A2:2021 IEC 62368-1: 2018 EN IEC 62368-1:2020+A11:2020 GB 4943.1–2022 IS 13252 (Part 1):2010 + A1:2013 + A2:2015 <b>EMI specific:</b> IEC 60601-1-2: 2014 +A1:2020 EN 60601-1-2: 2015 +A1:2021 FCC part 15 Class B ICES-003 Level B GB 17625.1-2022; GB/T 9254.1-2021

<b>Description</b>	<b>Configuration for MUIP-2213 STNW-NNN1</b>
<b>Processor (SoC)</b>	Intel® Pentium® N6415, Quad core @1.2GHz, 1.5 MB L2 Cache
<b>BIOS</b>	INSYDE
<b>Operating system</b>	Microsoft Windows 10 IoT LTSC / 11 IoT LTSC
<b>Networking</b>	Built-in Gigabit Ethernet LAN interfaces (2 ports)
<b>Memory</b>	8 GB DDR4 3200MHz RAM (module)
<b>Local storage</b>	128 GB M.2, PCIE module
<b>LCD panel characteristics</b>	13.3" TFT LCD 1920 x 1080 pixels resolution
<b>Audio system</b>	1x (3-in-1) audio earphone jack
<b>USB</b>	2 x USB 3.1 type A port 1 x USB 3.1 type C port under the rear cable cover
<b>Buttons and controls</b>	Power button on bottom-right side, reset pin-hole under connector cover
<b>Input device</b>	Touchscreen multi-touch (PCAP technology)
<b>Output</b>	Support Type C dongle transfer HDMI out
<b>Power source input</b>	12-24 Vdc
<b>Protection against electrical shocks</b>	Class I or II, depending on the class of the external power supply
<b>Operating temperature (for performance)</b>	10 °C to 35°C
<b>Operating Temperature (for safety)</b>	10°C to 40°C
<b>Operating humidity</b>	20% to 80% for performance

	10% to 90% for safety (non-condensing)
<b>Storage temperature</b>	-20 °C to 60 °C
<b>Storage humidity</b>	10% to 90% (non-condensing)
<b>Storage altitude</b>	70 to 110 kPa
<b>Operating altitude</b>	3000 m (Max)
<b>Ingress protection</b>	IPX3 (IPX0 for the external power supply)
<b>Durability</b>	Rugged anti-shock design
<b>Weight</b>	1.68 kg (typical) without desktop support 2.03 kg (typical) with desktop support
<b>Dimensions (W x H x D)</b>	334 x 226 x 38 mm
<b>Certifications &amp; compliance</b>	China: CCC Europe: CE (ITE), DEMKO US and Canada: UL, FCC, ICES-003 Japan: VCCI Australia: RCM India: BIS
<b>Standards</b>	AAMI ES60601-1:2005, ES60601-1:2005/AMD1:2012, ES60601-1:2005/AMD2:2021 CAN/CSA-C22.2 NO. 60601- 1:14/A2:2022 IEC 60601-1:2005, AMD1:2012, AMD2:2020 EN 60601-1:2006/A1:2013/A12:2014/A2:2021 IEC 62368-1: 2018 EN IEC 62368-1:2020+A11:2020 GB 4943.1-2022 IS 13252 (Part 1):2010 + A1:2013 + A2:2015 <b>EMI specific:</b> IEC 60601-1-2: 2014 +A1:2020 EN 60601-1-2: 2015 +A1:2021 FCC part 15 Class B ICES-003 Level B GB 17625.1-2022; GB/T 9254.1-2021

### Identification label position

The product identification label is located at the back of the MUIP-2213 as illustrated below.

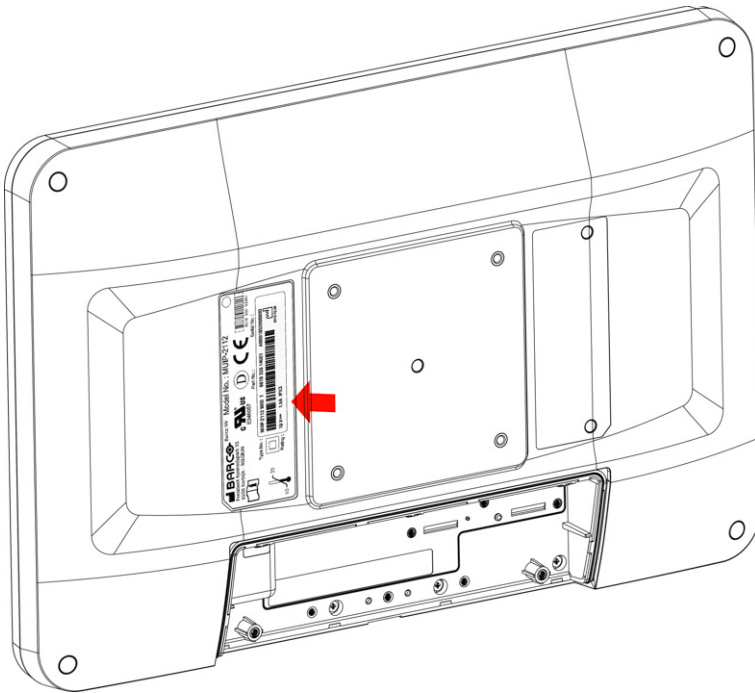

Image 4-1

Code number (12NC or K code) : (Model No.)

Serial number: 72yyww000000

- 72 = Original code (Italy)
- yy = Year
- ww = Week (01 to 52), manufacturing date
- 000000 = 6-digit progressive number





CE



R5916765 /02 | 2025-09-22

[www.barco.com](http://www.barco.com)