

MC2210511-PIR4-AO

Mellanox® MC2210511-PIR4 Compatible TAA 40GBase-IR4 QSFP+ Transceiver (SMF, 1310nm, 2km, MPO, DOM)

Features

- SFF-8436 Compliance
- MPO Connector
- Commercial Temperature 0 to 70 Celsius
- Single-mode Fiber
- Hot Pluggable
- Excellent ESD Protection
- Metal with Lower EMI
- RoHS Compliant and Lead Free



Applications

- 40GBase Ethernet
- Access and Enterprise

Product Description

This Mellanox® MC2210511-PIR4 compatible QSFP+ transceiver provides 40GBase-IR4 throughput up to 2km over single-mode fiber (SMF) using a wavelength of 1310nm via an MPO connector. It is guaranteed to be 100% compatible with the equivalent Mellanox® transceiver. This easy to install, hot swappable transceiver has been programmed, uniquely serialized and data-traffic and application tested to ensure that it will initialize and perform identically. Digital optical monitoring (DOM) support is also present to allow access to real-time operating parameters. This transceiver is Trade Agreements Act (TAA) compliant. We stand behind the quality of our products and proudly offer a limited lifetime warranty.

AddOn's transceivers are RoHS compliant and lead-free.

TAA refers to the Trade Agreements Act (19 U.S.C. & 2501-2581), which is intended to foster fair and open international trade. TAA requires that the U.S. Government may acquire only "U.S. – made or designated country end products."



Regulatory Compliance

- ESD to the Electrical PINs: compatible with MIL-STD-883E Method 3015.4
- ESD to the LC Receptacle: compatible with IEC 61000-4-3
- EMI/EMC compatible with FCC Part 15 Subpart B Rules, EN55022:2010
- Laser Eye Safety compatible with FDA 21CFR, EN60950-1& EN (IEC) 60825-1,2
- RoHS compliant with EU RoHS 2.0 directive 2015/863/EU

Absolute Maximum Ratings

| Parameter | Symbol | Min. | Typ. | Max. | Unit |
|---------------------------|--------|------|------|------|------|
| Supply Voltage | Vcc | 0 | | +3.6 | V |
| Storage Temperature | Tst | -40 | | +85 | °C |
| Humidity (non-condensing) | Rh | 5 | | 85 | % |

Recommended Operating Conditions

| Parameter | Symbol | Min. | Typ. | Max. | Unit |
|----------------------------|--------|-------|------|---------|------|
| Power Supply Voltage | Vcc | 3.13 | 3.3 | 3.47 | V |
| Operating Case Temperature | Tca | 0 | 25 | +70 | °C |
| Data Rate Per Channel | | | | 10.3125 | Gbps |
| Power Supply Voltage | Vcc | 3.135 | 3.3 | 3.465 | % |
| Power Supply Current | | | | 2.5 | W |

Electrical Characteristics

| Parameter | Symbol | Min. | Typ. | Max. | Unit | Notes |
|--|-----------------|-----------------|------|-----------------------|------------------|------------|
| Transmitter Differential Input Voltage | V _{IN} | 180 | | 800 | mV _{pp} | |
| Receiver Differential Output Voltage | V _O | 400 | 450 | 850 | mV _{pp} | 1 |
| Loss of Signal (LOS) | V _{CH} | 2 | | V _{CC} | V | 2 |
| | V _{OL} | V _{EE} | | V _{EE} + 0.8 | | |
| Transmitter Disable (TX-Disable) | V _{IH} | 2 | | V _{CC} | V | |
| | V _{IL} | V _{EE} | | V _{EE} + 0.8 | | |
| Rx Output Rise and Fall Time | Tr/Tf | 28 | | | Ps | 20% to 80% |

Notes:

1. SFF-8431, SFP+Module receiver output specifications at C'.

2. LOS is an open collector output. Should be pulled up with 4.7kΩ – 10kΩ on the host board. Normal operation is logic 0; loss of signal is logic 1.

Optical Characteristics

| Parameter | Symbol | Unit | Min. | Typ. | Max. | Notes |
|--|--|-------------------------------------|-------|------|-------|-------------------|
| Transmitter | | | | | | |
| Average Launch Power, each lane | Po | dBm | -8.2 | | +0.5 | |
| Center wavelength | λ_c | nm | 1260 | | 1355 | |
| Optical Spectral Width (RMS) | $\Delta\lambda$ | nm | | | 2.5 | |
| Extinction ratio | ER | Db | 3.0 | | | |
| Optical power OMA, each lane | POMA | dBm | -5.2 | | +1.5 | 1 |
| Average launch power of OFF transmitted, each lane | Poff | dBm | | | -30 | |
| RIN _{OMA} | RIN | dB/Hz | | | -128 | |
| Optical return loss tolerance | ORL _T | dB | 12 | | | 2 |
| Output eye | | Compliant with IEEE802.3ba eye mask | | | | |
| Receiver | | | | | | |
| Center Wavelength | λ_c | nm | 1260 | | 1355 | |
| Receiver Overload in OMA, each lane | RxOMA | dBm | +1.5 | | | |
| Receiver Overload in average power, each lane | Pmax | dBm | +0.5 | | | 3 |
| Average receive power, each lane | RxPx | dBm | -11.5 | | | 4 |
| Receiver Sensitivity in OMA, each lane | Sen _{OMA} | dBm | | | -9.5 | 5, for 1.0km type |
| Receiver Sensitivity in OMA, each lane | Sen _{OMA} | dBm | | | -10.5 | 5, for 1.5km type |
| Receiver Crossing | RCP | % | 45 | | 55 | |
| Receiver Eye Mask | SFF-8431, SFP+MODULE RECEIVER OUTPUT SPECIFICATIONS AT C'. | | | | | |
| Receiver Eye Mask Margin | REMM | % | 0 | | | |
| Receiver Reflectance | Rrx | dB | | | -12 | |
| LOS | Assert | LOSA | dBm | -30 | | |
| | De-assert | LOSD | dBm | | | -12 |
| LOS Hysteresis | LOSH | dB | 0.5 | | 6 | |

Notes:

1. Even if the TDP < 1 dB, the OMA (min) must exceed this value.
2. Transmitter reflectance is defined looking into the transmitter
3. The receiver shall be able to tolerate, without damage, continuous exposure to an optical input signal having a power level equal to the average receive power (max) plus at least 1 dB.

4. Average receive power (min) is informative and not the principal indicator of signal strength. A received power below this value cannot be compliant; however, a value above this does not ensure compliance.
5. PRBS 231 -1 at BER 10-12 , ER=3.0dB

Digital Diagnostic Memory Map

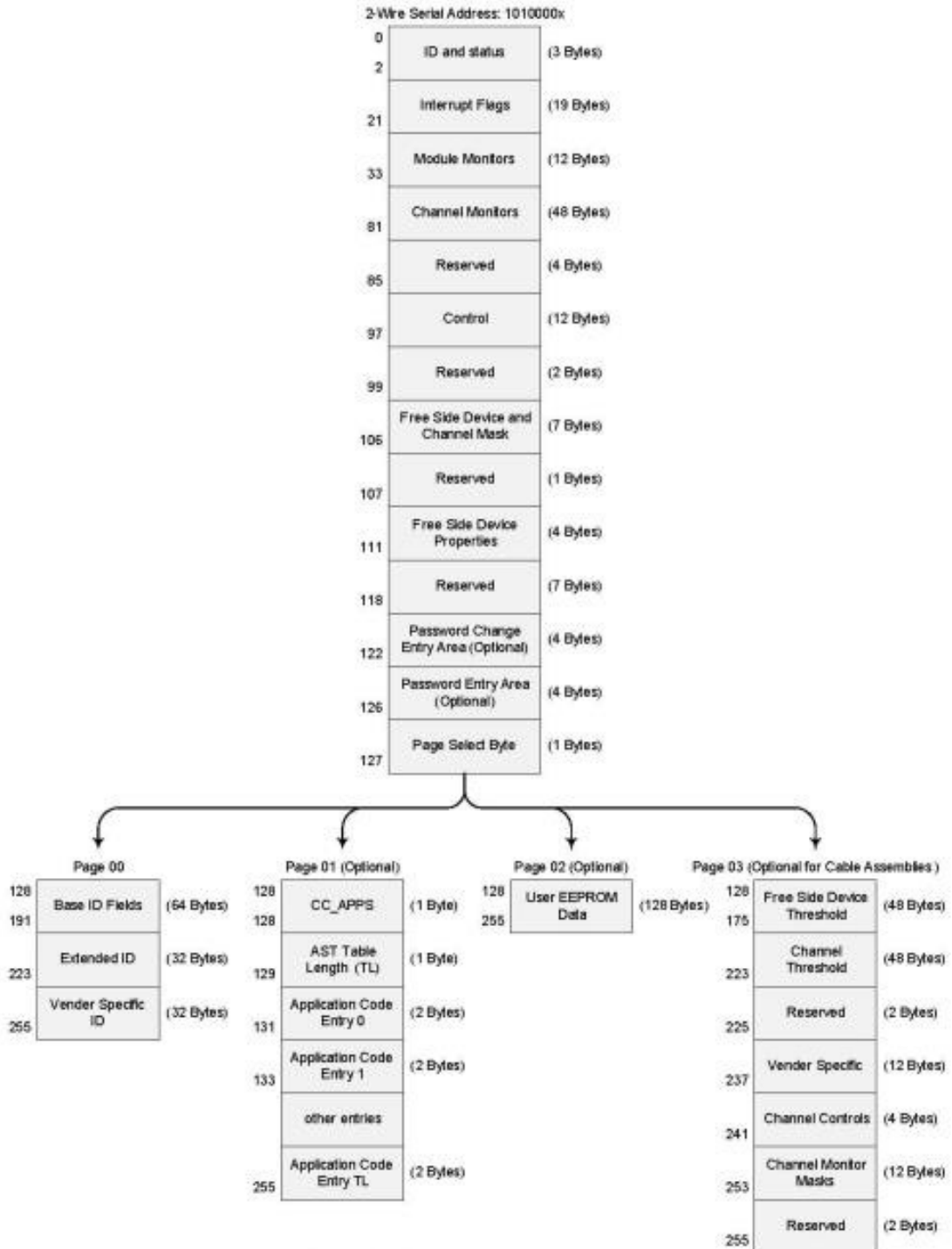

Pin Descriptions

| Pin | Logic | Symbol | Name/Descriptions | Ref. |
|-----|-------------|---------|--|------|
| 1 | | GND | Module Ground | 1 |
| 2 | CML-I | Tx2- | Transmitter inverted data input | |
| 3 | CML-I | Tx2+ | Transmitter non-inverted data input | |
| 4 | | GND | Module Ground | 1 |
| 5 | CML-I | Tx4- | Transmitter inverted data input | |
| 6 | CML-I | Tx4+ | Transmitter non-inverted data input | |
| 7 | | GND | Module Ground | 1 |
| 8 | LVTTTL-I | MODSEIL | Module Select | 2 |
| 9 | LVTTTL-I | ResetL | Module Reset | 2 |
| 10 | | VCCRx | +3.3v Receiver Power Supply | |
| 11 | LVC MOS-I | SCL | 2-wire Serial interface clock | 2 |
| 12 | LVC MOS-I/O | SDA | 2-wire Serial interface data | 2 |
| 13 | | GND | Module Ground | 1 |
| 14 | CML-O | RX3+ | Receiver non-inverted data output | |
| 15 | CML-O | RX3- | Receiver inverted data output | |
| 16 | | GND | Module Ground | 1 |
| 17 | CML-O | RX1+ | Receiver non-inverted data output | |
| 18 | CML-O | RX1- | Receiver inverted data output | |
| 19 | | GND | Module Ground | 1 |
| 20 | | GND | Module Ground | 1 |
| 21 | CML-O | RX2- | Receiver inverted data output | |
| 22 | CML-O | RX2+ | Receiver non-inverted data output | |
| 23 | | GND | Module Ground | 1 |
| 24 | CML-O | RX4- | Receiver inverted data output | |
| 25 | CML-O | RX4+ | Receiver non-inverted data output | |
| 26 | | GND | Module Ground | 1 |
| 27 | LVTTTL-O | ModPrsL | Module Present, internal pulled down to GND | |
| 28 | LVTTTL-O | IntL | Interrupt output should be pulled up on host board | 2 |
| 29 | | VCCTx | +3.3v Transmitter Power Supply | |
| 30 | | VCC1 | +3.3v Power Supply | |
| 31 | LVTTTL-I | LPMODE | Low Power Mode | 2 |
| 32 | | GND | Module Ground | 1 |
| 33 | CML-I | Tx3+ | Transmitter non-inverted data input | |
| 34 | CML-I | Tx3- | Transmitter inverted data input | |
| 35 | | GND | Module Ground | 1 |
| 36 | CML-I | Tx1+ | Transmitter non-inverted data input | |
| 37 | CML-I | Tx1- | Transmitter inverted data input | |
| 38 | | GND | Module Ground | 1 |

Notes:

1. GND is the symbol for signal and supply (power) common for QSFP+ modules. All are common within the QSFP+ module and all module voltages are referenced to this potential unless otherwise noted. Connect these directly to the host board signal common ground plane.
2. VccRx, Vcc1 and VccTx are the receiver and transmitter power suppliers and shall be applied concurrently. Recommended host board power supply filtering is shown in the figure below. Vcc Rx, Vcc1 and VccTx may be internally connected within the QSFP+ transceiver module in any combination. The connector pins are each rated for a maximum current of 500mA.

Electrical Pin-out Details

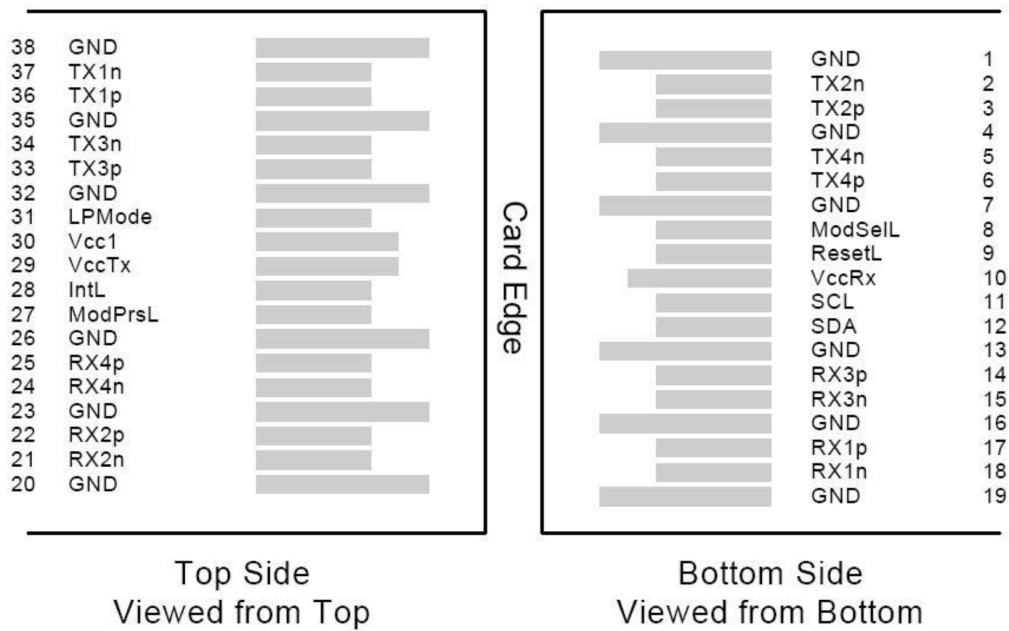

Recommended Power Supply Filter

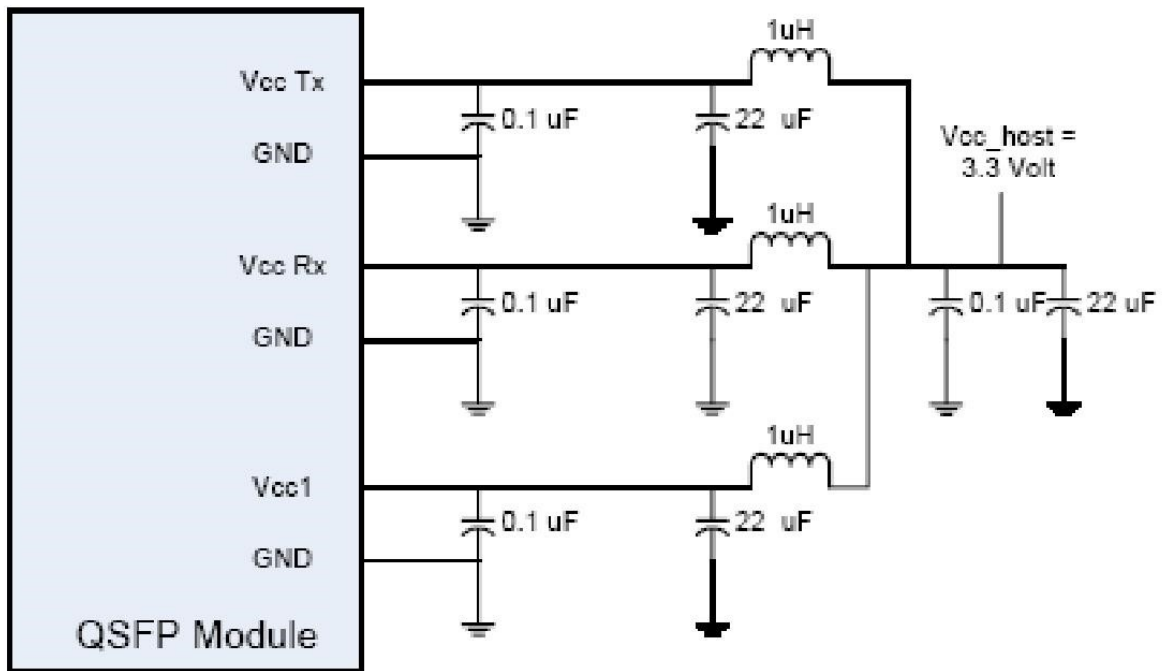

Typical Application Circuit

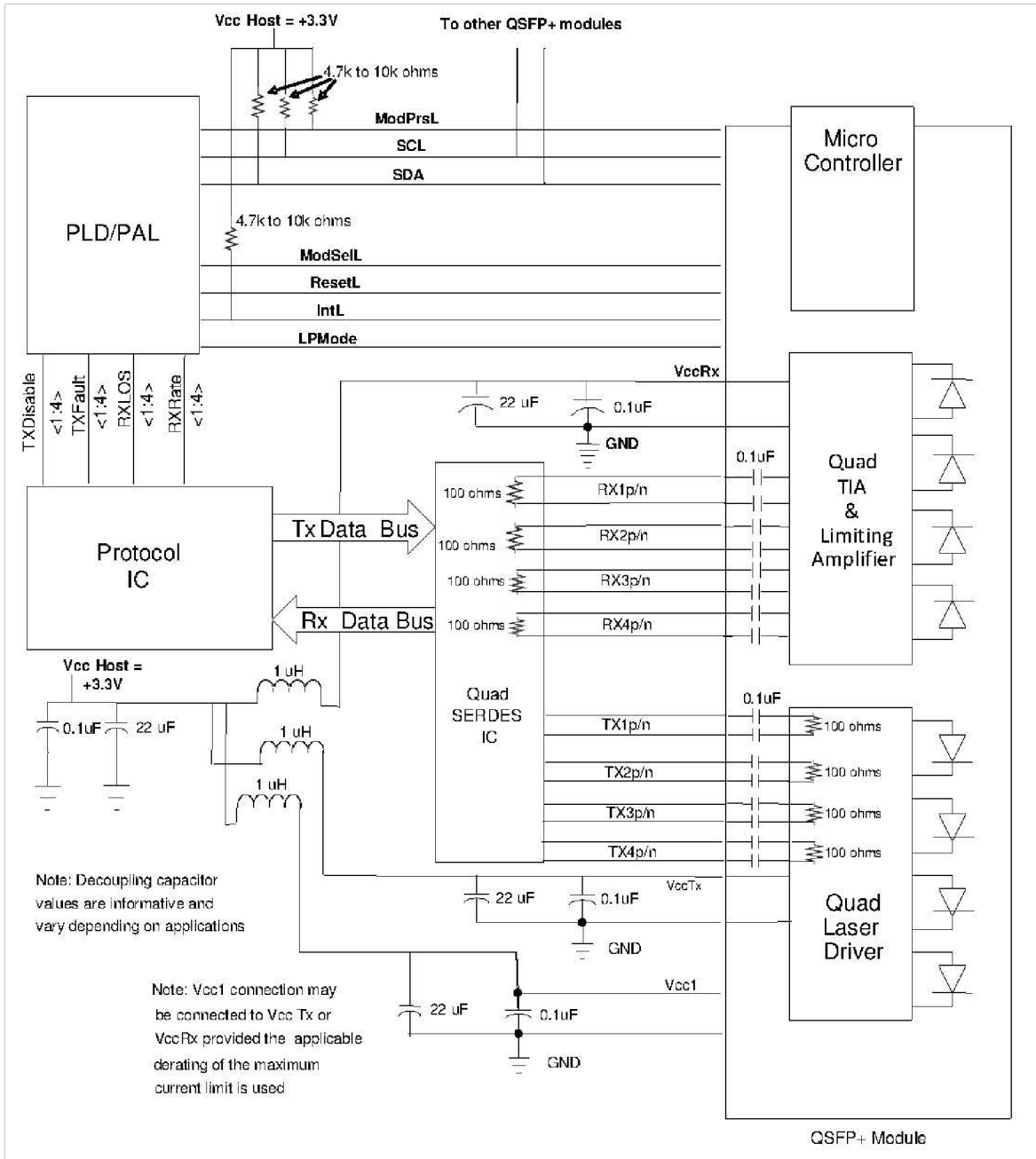

Mechanical Specifications

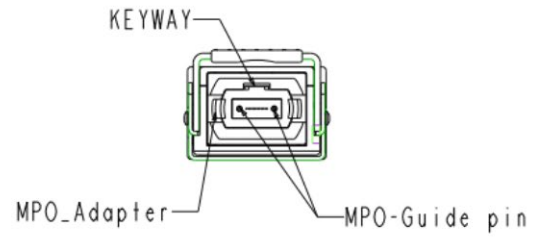
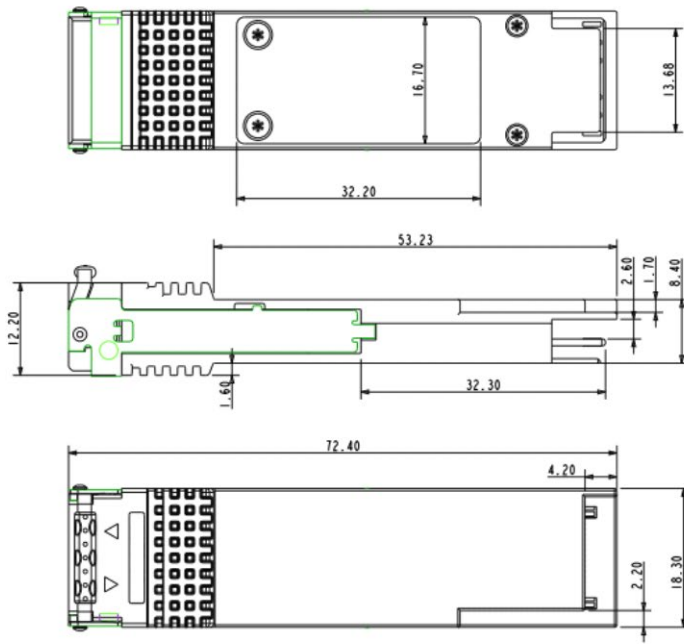

About AddOn Networks

In 1999, AddOn Networks entered the market with a single product. Our founders fulfilled a severe shortage for compatible, cost-effective optical transceivers that compete at the same performance levels as leading OEM manufacturers. Adhering to the idea of redefining service and product quality not previously had in the fiber optic networking industry, AddOn invested resources in solution design, production, fulfillment, and global support.

Combining one of the most extensive and stringent testing processes in the industry, an exceptional free tech support center, and a consistent roll-out of innovative technologies, AddOn has continually set industry standards of quality and reliability throughout its history.

Reliability is the cornerstone of any optical fiber network and is engrained in AddOn's DNA. It has played a key role in nurturing the long-term relationships developed over the years with customers. AddOn remains committed to exceeding industry standards with certifications from ranging from NEBS Level 3 to ISO 9001:2005 with every new development while maintaining the signature reliability of its products.

U.S. Headquarters

Email: sales@addonnetworks.com

Telephone: +1 877.292.1701

Fax: 949.266.9273

Europe Headquarters

Email: salesupportemea@addonnetworks.com

Telephone: +44 1285 842070