

## LI-2399(3299)-40D-xx

**LinkIT SFP+ 10Gbps BiDI 40km xx, LC, DDM, Single-mode,**

**TX/RX:1270/1330nm(TX/RX: 1330/1270nm)**

### **PRODUCT FEATURES**

- Support data rate up to 11.3Gb/s
- Hot-Pluggable SFP Footprint and Single LC Connector
- Up to 40km reach for G.652 SMF
- 1270nm DFB Transmitter and PIN receiver for LI-2399-40D-xx  
1330nm DFB Transmitter and PIN receiver for LI-3299-40D-xx
- Temperature Range: Commercial:0°C ~+70°C
- Compliant with SFP-8431
- Compliant with SFP-8432
- Compliant with SFP-8472
- Compliant with IEEE802.3ae

### **APPLICATIONS**

- 10G Ethernet
- OTU2/2e
- Other Optical Links

## Ordering information

Package	Product part NO.	Data Rate(Gbps)	Media	Transmission Distance (km)	Temperature Range (°C)		Wavelength (nm)	Power Dissipation (W)
						Commercial		
SFP+	LI-2399-40D-xx	10.3125	SMF	40	0~70	Commercial	1270 TX/1330 RX	<1.0
SFP+	LI-3299-40D-xx	10.3125	SMF	40	0~70	Commercial	1330 TX/1270 RX	<1.0

## I. Absolute Maximum Ratings

Parameter	Symbol	Min.	Max.	Unit
Storage Temperature	TS	-40	+85	°C
Maximum Supply Voltage	VCC	-0.5	3.6	V
Operating Relative Humidity	RH		95	%

## II. Recommended Operating Conditions

Parameter	Symbol	Min.	Typ.	Max.	Unit	Note
Case Operating Temperature	Top	0	-	70	°C	Commercial
Power Supply Voltage	VCC	3.13	3.3	3.47	V	
Data Rate	BR		10.3125	11.3	Gbps	
Transmission Distance	TD			40	km	
Coupled fiber	Single mode fiber					9/125um SMF

## III. Electrical Characteristics (TOP = Tc, Vcc = 3.135 to 3.465 Volts)

Parameter	Symbol	Min.	Typical	Max.	Unit	Note
Supply Voltage	Vcc	3.135		3.465	V	
Supply Current (Commercial)	Icc			300	mA	
Supply Current (Industrial)	Icc			450	mA	
Power Consumption (Commercial)	P			1.0	W	
Power Consumption (Industrial)	P			1.5	W	

Transmitter Section						
CML Inputs(Differential)	Vin	150		1200	mVpp	1
Input Impedance(Differential)	Zin	85	100	115	ohm	
TX_DIS Disable		2		Vcc+0.3	V	
TX_DIS Enable		0		0.8	V	
TX_FAULT Fault		2		Vcc+0.3	V	
TX_FAULT Normal		0		0.5	V	
Receiver Section						
CML Outputs (Differential)	Vout	350		700	mVpp	1
Output Impedance (Differential)	Zout	85	100	115	Ohm	
RX_LOS LOS		2		Vcc+0.3	V	2
RX_LOS Normal		0		0.8	V	2
MOD_DEF ( 0:2 ) VoH		2.5			V	With Serial ID
MOD_DEF ( 0:2 ) VoL		0		0.5	V	With Serial ID

Note:

1. CML logic, internally AC coupled.
2. Loss Of Signal is LVTTTL. Logic 0 indicates normal operation; logic 1 indicates no signal detected.

## IV. Optical Characteristics

Parameter	Symbol	Min.	Typ.	Max.	Unit	NOTE
Data Rate			10.3125	11.3	Gbps	
Transmitter						
Center Wavelength	$\lambda$	1260	1270	1280	nm	LXP-B2733-40D (I)
		1320	1330	1340	nm	LXP-B3327-40D (I)
Spectral Width (-20dB)	$\Delta\lambda$			1	nm	
Side Mode Suppression Ratio	SMSR	30			dB	
Average Output Power	Pout	0		5	dBm	1
Extinction Ratio	ER	3.5			dB	
Average Power of OFF Transmitter	Poff			-30	dBm	
Relative Intensity Noise	RIN			-128	dB/Hz	2
Receiver						
Wavelength Range	$\lambda_c$	1260	1270	1280	nm	LXP-B2733-40D (I)

		1320	1330	1340	nm	LXP-B3327-40D (1)
Receiver Sensitivity	Pmin			-15	dBm	3
Receiver Overload	Pmax	0.5			dBm	
LOS De-Assert	LOSD			-18	dBm	
LOS Assert	LOSA	-30			dBm	
LOS-Hysteresis	Phys	0.5		6	dB	

Notes:

1. Output is coupled into a 9/125um SMF.
2. 12dB reflection.
3. Measured with worst ER, BER less than 1E-12 and PRBS 2<sup>31</sup>-1 at 10.3125Gbps.

## V. Digital Diagnostic Functions

Parameter	Range	Unit	Accuracy	Calibration
Commercial Temperature	0 to +70	°C	±3°C	Internal / External
Industrial Temperature	-40 to +85	°C	±3°C	Internal / External
Voltage	3.0 to 3.6	V	±3%	Internal / External
Bias Current	10 to 100	mA	±10%	Internal / External
TX Power	0 to +5	dBm	±3dB	Internal / External
RX Power	-15 to +0.5	dBm	±3dB	Internal / External

Note:

The transceivers provide serial ID memory contents and diagnostic information about the present operating conditions by the 2-wire serial interface (SCL, SDA). The diagnostic information with internal calibration or external calibration all are implemented, including received power monitoring, transmitted power monitoring, bias current monitoring, supply voltage monitoring and temperature monitoring.

## VI. Timing Characteristics

Parameter	Symbol	Min.	Typical	Max.	Unit
TX_Disable Assert Time	t_off			100	us
TX_Disable Negate Time	t_on			2	ms
Time to Initialize Include Reset of TX_FAULT	t_int			300	ms
TX_FAULT from Fault to Assertion	t_fault			100	us
TX_Disable Time to Start Reset	t_reset	10			us
Receiver Loss of Signal Assert Time	T <sub>A,RX_LOS</sub>			100	us
Receiver Loss of Signal Deassert Time	T <sub>d,RX_LOS</sub>			100	us
Rate-Select Chage Time	t_ratesel			10	us
Serial ID Clock Time	t_serial-clock			100	kHz

## VII. SFP Module EEPROM Information and Management

The SFP modules implement the 2-wire serial communication protocol as defined in the SFP -8472. The serial ID information of the SFP modules and Digital Diagnostic Monitor parameters can be accessed through the I2C interface at address A0h and A2h.

The memory is mapped in Table 1.

Detailed ID information (A0h) is listed in Table 2.

And the DDM specification at address A2h.

For more details of the memory map and byte definitions, please refer to the SFF-8472, “Digital Diagnostic Monitoring Interface for Optical Transceivers”. The DDM parameters have been internally calibrated.

**Table 1-** Digital Diagnostic Memory Map (Specific Data Field Descriptions)

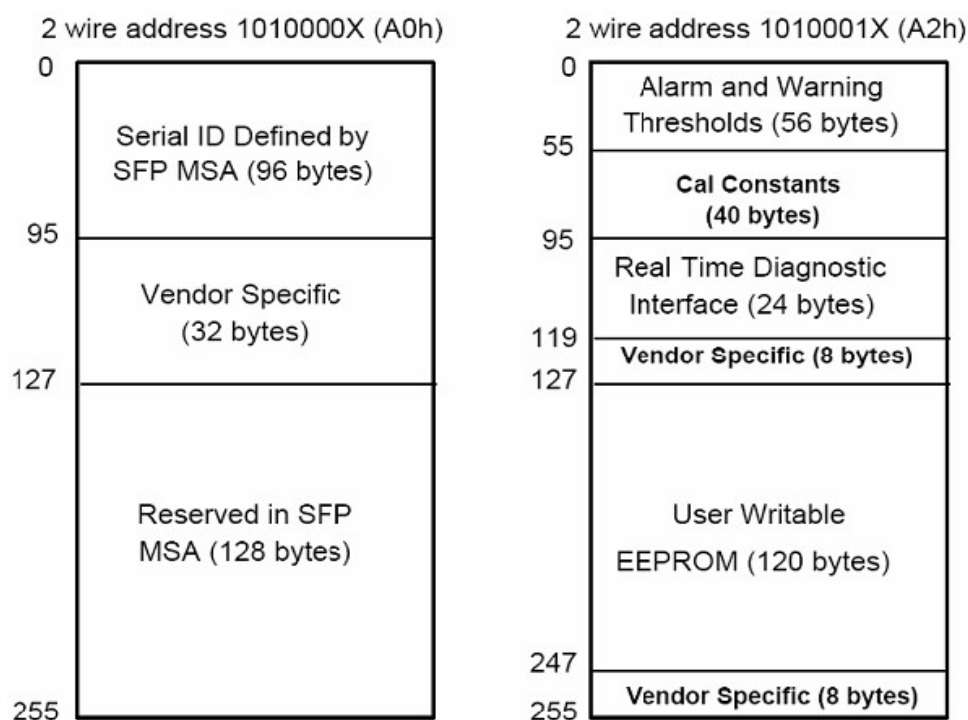

**Table 2 -** EEPROM Serial ID Memory Contents (A0h)

Data Address	Length (Byte)	Name of Length	Description and Contents
<b>Base ID Fields</b>			
0	1	Identifier	Type of Serial transceiver (03h=SFP)
1	1	Reserved	Extended identifier of type serial transceiver (04h)
2	1	Connector	Code of optical connector type (07=LC)
3-10	8	Transceiver	10G Base-ER
11	1	Encoding	64B/66B
12	1	BR, Nominal	Nominal baud rate, unit of 100Mbps
13-14	2	Reserved	(0000h)
15	1	Length(9um)	Link length supported for 9/125um fiber, units of 100m
16	1	Length(50um)	Link length supported for 50/125um fiber, units of 10m

17	1	Length(62.5um)	Link length supported for 62.5/125um fiber, units of 10m
18	1	Length(Copper)	Link length supported for copper, units of meters
19	1	Reserved	
20-35	16	Vendor Name	SFP vendor name: LIGHTREND
36	1	Reserved	
37-39	3	Vendor OUI	SFP transceiver vendor OUI ID
40-55	16	Vendor PN	Part Number: "LXP-BXXXX" (ASCII)
56-59	4	Vendor rev	Revision level for part number
60-62	3	Reserved	
63	1	CCID	Least significant byte of sum of data in address 0-62
<b>Extended ID Fields</b>			
64-65	2	Option	Indicates which optical SFP signals are implemented (001Ah = LOS, TX_FAULT, TX_DISABLE all supported)
66	1	BR, max	Upper bit rate margin, units of %
67	1	BR, min	Lower bit rate margin, units of %
68-83	16	Vendor SN	Serial number (ASCII)
84-91	8	Date code	LIGHTREND's Manufacturing date code
92-94	3	Reserved	
95	1	CCEX	Check code for the extended ID Fields (addresses 64 to 94)
<b>Vendor Specific ID Fields</b>			
96-127	32	Readable	LIGHTREND specific date, read only
128-255	128	Reserved	Reserved for SFF-8079

**Table 3 - Alarm and Warning Thresholds (A2h)**

Data Address	Length (Byte)	Name of Length	Description and Contents
<b>Base ID Fields</b>			
00-01	2	Temp High Alarm	MSB at low address
02-03	2	Temp Low Alarm	MSB at low address
04-05	2	Temp High Warning	MSB at low address
06-07	2	Temp Low Warning	MSB at low address
08-09	2	Voltage High Alarm	MSB at low address
10-11	2	Voltage Low Alarm	MSB at low address
12-13	2	Voltage High Warning	MSB at low address
14-15	2	Voltage Low Warning	MSB at low address
16-17	2	Bias High Alarm	MSB at low address
18-19	2	Bias Low Alarm	MSB at low address

20-21	2	Bias High Warning	MSB at low address
22-23	2	Bias Low Warning	MSB at low address
24-25	2	TX Power High Alarm	MSB at low address
26-27	2	TX Power Low Alarm	MSB at low address
28-29	2	TX Power High Warning	MSB at low address
30-31	2	TX Power Low Warning	MSB at low address
32-33	2	RX Power High Alarm	MSB at low address
34-35	2	RX Power Low Alarm	MSB at low address
36-37	2	RX Power High Warning	MSB at low address
38-39	2	RX Power Low Warning	MSB at low address
40-41	2	Optional Laser Temp High Alarm	MSB at low address
42-43	2	Optional Laser Temp Low Alarm	MSB at low address
44-45	2	Optional Laser Temp High Warning	MSB at low address
46-47	2	Optional Laser Temp Low Warning	MSB at low address
48-49	2	Optional TEC Current High Alarm	MSB at low address
50-51	2	Optional TEC Current Low Alarm	MSB at low address
52-53	2	Optional TEC Current High Warning	MSB at low address
54-55	3	Optional TEC Current Low Warning	MSB at low address
<b>Calibration Constants for External Calibration Option</b>			
56-91	36	Calibration Constants for External	Refer to the SFP 8472 Rev12.4

		Calibration Option	
92-94	3	Reserved	
95	1	Checksum	Byte 95 contains the low order 8 bits of the sum of bytes 0-94
<b>Real Time Diagnostic and Control Registers</b>			
96-110	15	A/D Values and Status Bits	Refer to the SFP 8472 Rev12.4
111	1	Reserved	Reserved (was assigned to SFF-8079).
<b>Alarm and Warning Flag Bits</b>			
112-117	6	Optional Alarm and Warning Flag Bits	Refer to the SFP 8472 Rev12.4
<b>Extended Module Control/Status Bytes</b>			
118-119	2	Extended Module Control/Status Bytes	Refer to the SFP 8472 Rev12.4
<b>Optional Page Select Byte</b>			
120-126	7	Vendor Specific	Vendor specific memory addresses
127	1	Optional Page Select	Defines the page number for subsequent reads and writes to locations A2h
<b>User Accessible EEPROM Locations</b>			
128-247	120	User EEPROM	User writable EEPROM
<b>Vendor Specific Control Function Locations</b>			
248-255	8	Vendor Specific	Vendor specific control functions

## VIII.Pin Diagram

Diagram of Host Board Connector Block Pin Numbers and Name

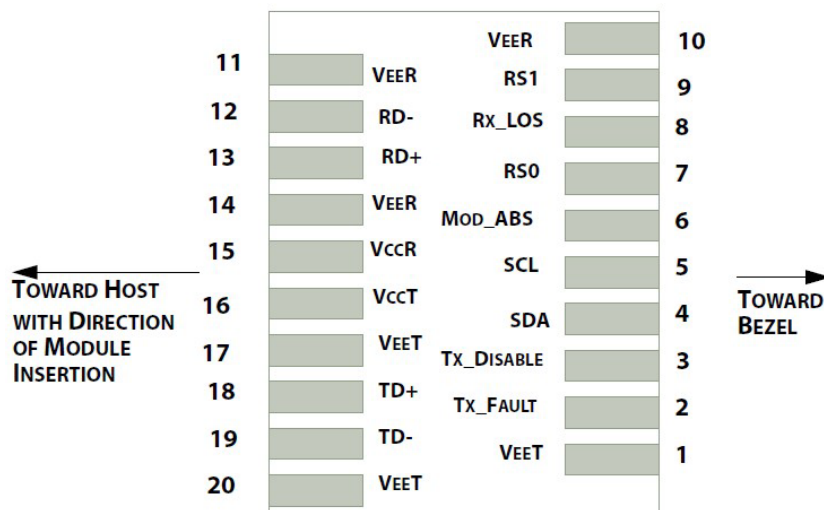



## IX. Pin Descriptions

PIN #	Name	Function	Notes
1	VeeT	Module transmitter ground	1
2	Tx Fault	Module transmitter fault	2
3	Tx Disable	Transmitter Disable; Turns off transmitter laser output	3
4	SDL	2 wire serial interface data input/output (SDA)	4
5	SCL	2 wire serial interface clock input (SCL)	4
6	MOD-ABS	Module Absent, connect to VeeR or VeeT in the module	4
7	RS0	Rate select0, optionally control SFP+ receiver. When high, input data rate >4.5Gb/s; when low, input data rate <=4.5Gb/s	5
8	LOS	Receiver Loss of Signal Indication	6
9	RS1	Rate select0, optionally control SFP+ transmitter. When high, input data rate >4.5Gb/s; when low, input data rate <=4.5Gb/s	1
10	VeeR	Module receiver ground	1
11	VeeR	Module receiver ground	1
12	RD-	Receiver inverted data out put	
13	RD+	Receiver non-inverted data out put	
14	VeeR	Module receiver ground	1
15	VccR	Module receiver 3.3V supply	
16	VccT	Module transmitter 3.3V supply	
17	VeeT	Module transmitter ground	1
18	TD+	Transmitter inverted data out put	
19	TD-	Transmitter non-inverted data out put	
20	VeeT	Module transmitter ground	1

Note:

1. Circuit ground is internally isolated from chassis ground
2. Tx FAULT is an open collector/drain output, which should be pulled up with a 4.7k – 10k Ohms resistor on the host board if intended for use. Pull up voltage should be between 2.0V to Vcc + 0.3V. A high output indicates a transmitter fault caused by either the TX bias current or the TX output power exceeding the preset alarm thresholds. A low output indicates normal operation. In the low state, the output is pulled to <0.8V.
3. Laser output disabled on Tx DIS >2.0V or open, enabled on Tx DIS <0.8V.
4. Should be pulled up with 4.7kΩ- 10kΩ host board to a voltage between 2.0V and 3.6V. MOD\_ABS pulls line low to indicate module is plugged in.
5. Internally pulled down per SFF-8431 Rev 4.1.
6. LOS is open collector output. It should be pulled up with 4.7kΩ – 10kΩ on host board to a voltage between 2.0V and 3.6V. Logic 0 indicates normal operation; logic 1 indicates loss of signal.

## X. Recommend Circuit Schematic

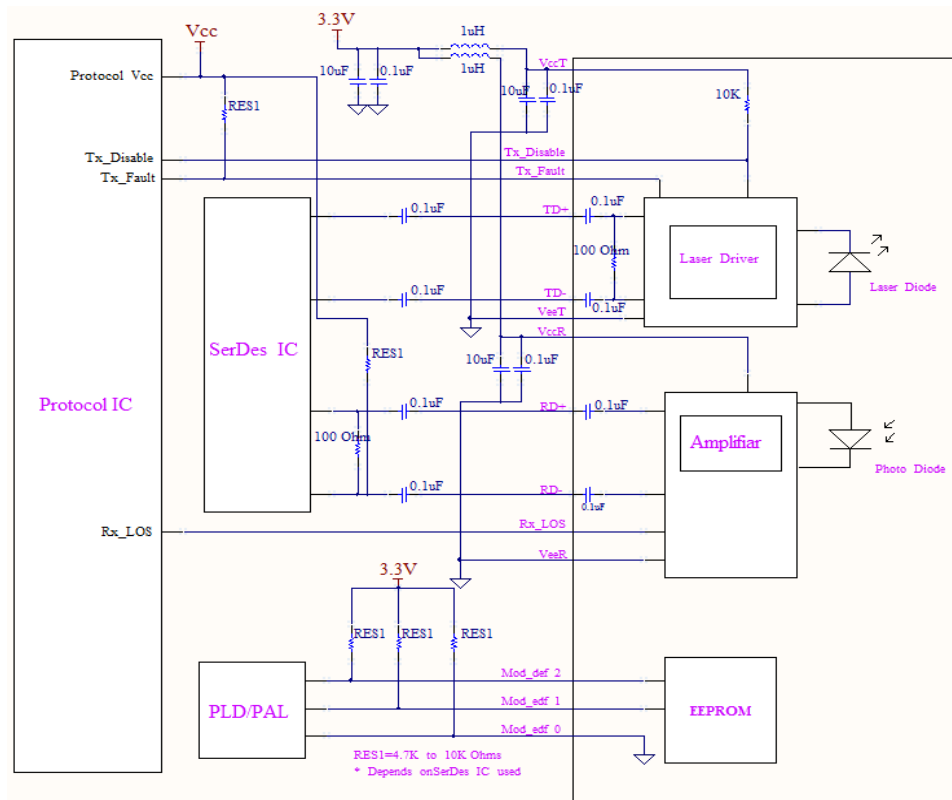

## XI. Mechanical Specifications(Unit: mm)

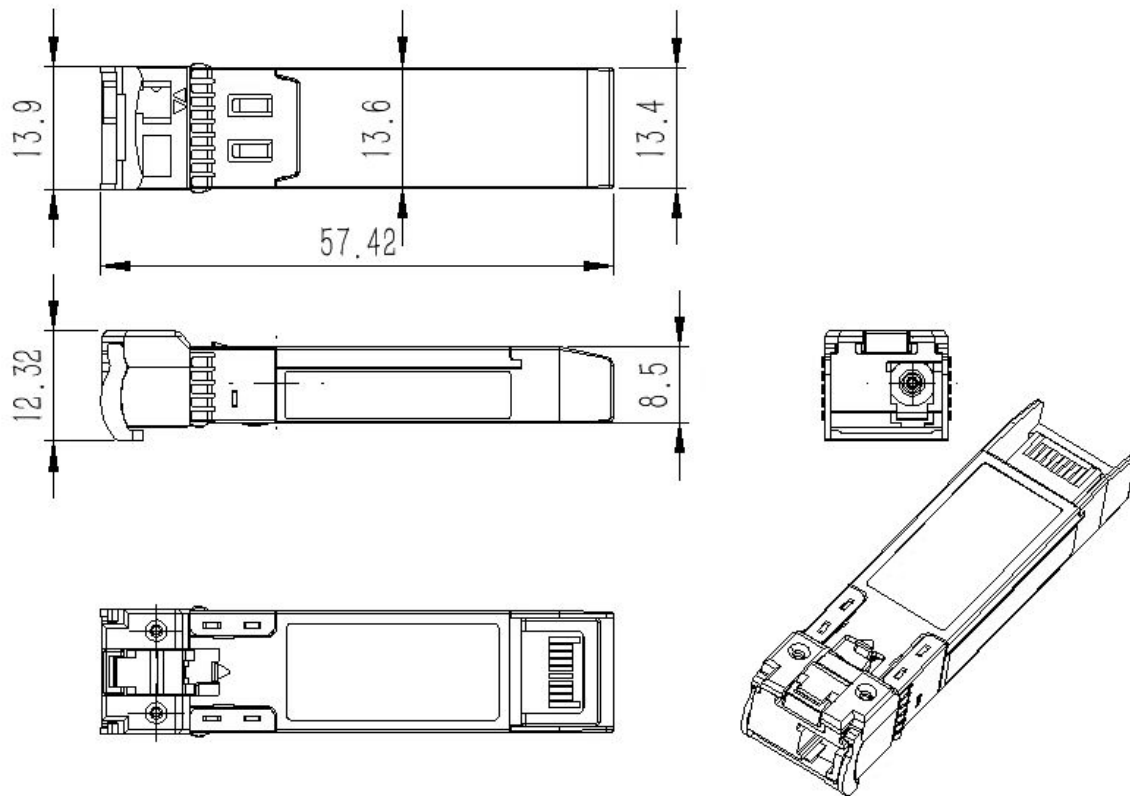

## XII. Regulatory Compliance

Feature	Reference	Performance
ROHS	BSTDG211221022106CR	Compatible with standards
EMC CE	BSTXD211221003604ER	Compatible with standards
FCC	BSTXD211221022117EC	Compatible with standards

## Revision History

Version No.	Date	Description
1.0	June 13, 2021	Preliminary datasheet

Imported and distributed by CBK Group AS

Gneisveien 30

2020 Skedsmokorset