

SUPERO®

SUPERSERVER

6017B-MTF

6017B-MTLF

6017B-MTRF

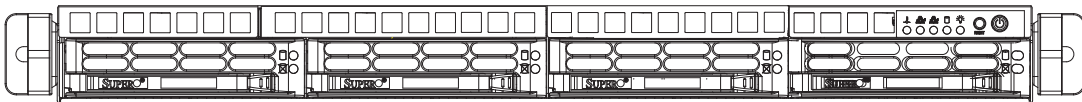

USER'S MANUAL

1.0

The information in this User's Manual has been carefully reviewed and is believed to be accurate. The vendor assumes no responsibility for any inaccuracies that may be contained in this document, makes no commitment to update or to keep current the information in this manual, or to notify any person or organization of the updates. **Please Note: For the most up-to-date version of this manual, please see our web site at www.supermicro.com.**

Super Micro Computer, Inc. ("Supermicro") reserves the right to make changes to the product described in this manual at any time and without notice. This product, including software and documentation, is the property of Supermicro and/or its licensors, and is supplied only under a license. Any use or reproduction of this product is not allowed, except as expressly permitted by the terms of said license.

IN NO EVENT WILL SUPERMICRO BE LIABLE FOR DIRECT, INDIRECT, SPECIAL, INCIDENTAL, SPECULATIVE OR CONSEQUENTIAL DAMAGES ARISING FROM THE USE OR INABILITY TO USE THIS PRODUCT OR DOCUMENTATION, EVEN IF ADVISED OF THE POSSIBILITY OF SUCH DAMAGES. IN PARTICULAR, SUPERMICRO SHALL NOT HAVE LIABILITY FOR ANY HARDWARE, SOFTWARE, OR DATA STORED OR USED WITH THE PRODUCT, INCLUDING THE COSTS OF REPAIRING, REPLACING, INTEGRATING, INSTALLING OR RECOVERING SUCH HARDWARE, SOFTWARE, OR DATA.

Any disputes arising between manufacturer and customer shall be governed by the laws of Santa Clara County in the State of California, USA. The State of California, County of Santa Clara shall be the exclusive venue for the resolution of any such disputes. Super Micro's total liability for all claims will not exceed the price paid for the hardware product.

FCC Statement: This equipment has been tested and found to comply with the limits for a Class A digital device pursuant to Part 15 of the FCC Rules. These limits are designed to provide reasonable protection against harmful interference when the equipment is operated in a commercial environment. This equipment generates, uses, and can radiate radio frequency energy and, if not installed and used in accordance with the manufacturer's instruction manual, may cause harmful interference with radio communications. Operation of this equipment in a residential area is likely to cause harmful interference, in which case you will be required to correct the interference at your own expense.

California Best Management Practices Regulations for Perchlorate Materials: This Perchlorate warning applies only to products containing CR (Manganese Dioxide) Lithium coin cells. "Perchlorate Material-special handling may apply. See www.dtsc.ca.gov/hazardouswaste/perchlorate"

WARNING: Handling of lead solder materials used in this product may expose you to lead, a chemical known to the State of California to cause birth defects and other reproductive harm.

Manual Revision 1.0
Release Date: August 7, 2012

Unless you request and receive written permission from Super Micro Computer, Inc., you may not copy any part of this document.

Information in this document is subject to change without notice. Other products and companies referred to herein are trademarks or registered trademarks of their respective companies or mark holders.

Copyright © 2012 by Super Micro Computer, Inc.
All rights reserved.
Printed in the United States of America

Preface

About This Manual

This manual is written for professional system integrators and PC technicians. It provides information for the installation and use of the SuperServer 6017B-MTF/6017B-MTLF/6017B-MTRF. Installation and maintenance should be performed by experienced technicians only.

The SuperServer 6017B-MTF/6017B-MTLF/6017B-MTRF is a high-end server based on the SC813MTQ-441CB/SC813MTQ-350CB/SC813MTQ-R400CB 1U rackmount chassis and the Super X9DBL-iF dual processor serverboard.

Manual Organization

Chapter 1: Introduction

The first chapter provides a checklist of the main components included with the server system and describes the main features of the X9DBL-iF serverboard and the SC813MTQ chassis.

Chapter 2: Server Installation

This chapter describes the steps necessary to install the SuperServer 6017B-MTF/6017B-MTLF/6017B-MTRF into a rack and check out the server configuration prior to powering up the system.

Chapter 3: System Interface

Refer here for details on the system interface, which includes the functions and information provided by the control panel on the chassis as well as other LEDs located throughout the system.

Chapter 4: System Safety

You should thoroughly familiarize yourself with this chapter for a general overview of safety precautions that should be followed when installing and servicing the SuperServer 6017B-MTF/6017B-MTLF/6017B-MTRF.

Chapter 5: Advanced Serverboard Setup

Chapter 5 provides detailed information on the X9DBL-iF serverboard, including the locations and functions of connections, headers and jumpers. Refer to this chapter when adding or removing processors or main memory and when reconfiguring the serverboard.

Chapter 6: Advanced Chassis Setup

Refer to Chapter 6 for detailed information on the SC813MTQ server chassis. You should follow the procedures given in this chapter when installing, removing or reconfiguring SATA or peripheral drives and when replacing system power supply modules and cooling fans.

Chapter 7: BIOS

The BIOS chapter includes an introduction to BIOS and provides detailed information on running the CMOS Setup Utility.

Appendix A: POST Error Beep Codes

Appendix B: System Specifications

Notes

Table of Contents

Chapter 1 Introduction

1-1	Overview	1-1
1-2	Serverboard Features	1-2
	Processors	1-2
	Memory	1-2
	SATA.....	1-2
	I/O Ports	1-2
1-3	Server Chassis Features	1-2
	System Power	1-2
	Hard Drives	1-3
	Control Panel	1-3
	Cooling System.....	1-3
1-4	Contacting Supermicro.....	1-5

Chapter 2 Server Installation

2-1	Overview	2-1
2-2	Unpacking the System	2-1
2-3	Preparing for Setup.....	2-1
	Choosing a Setup Location.....	2-1
	Rack Precautions	2-2
	Server Precautions.....	2-2
	Rack Mounting Considerations	2-3
	Ambient Operating Temperature	2-3
	Reduced Airflow	2-3
	Mechanical Loading	2-3
	Circuit Overloading.....	2-3
	Reliable Ground	2-3
2-4	Installing the System into a Rack	2-4
	Identifying the Sections of the Rack Rails	2-4
	Installing the Rear Inner Rails	2-4
	Installing the Rack Rails	2-5
	Installing the Server into the Rack.....	2-6
	Installing the Server into a Telco Rack.....	2-7

Chapter 3 System Interface

3-1	Overview	3-1
3-2	Control Panel Buttons	3-1
	Reset.....	3-1

	Power	3-1
3-3	Control Panel LEDs	3-2
	Information LED	3-2
	NIC1	3-2
	NIC2	3-2
	HDD.....	3-2
	Power	3-3
3-4	Hard Drive Carrier LEDs.....	3-3
Chapter 4 System Safety		
4-1	Electrical Safety Precautions	4-1
4-2	General Safety Precautions	4-2
4-3	ESD Precautions.....	4-3
4-4	Operating Precautions	4-4
Chapter 5 Advanced Serverboard Setup		
5-1	Handling the Serverboard	5-1
	Precautions	5-1
	Unpacking	5-1
5-2	Processor and Heatsink Installation.....	5-2
	Installing an LGA 1356 Processor	5-2
	Installing a CPU Heatsink	5-4
5-3	Connecting Cables.....	5-5
	Connecting Data Cables	5-5
	Connecting Power Cables	5-5
	Connecting the Control Panel.....	5-5
5-4	I/O Ports	5-6
5-5	Installing Memory	5-7
5-6	Adding PCI Cards	5-10
5-7	Serverboard Details	5-11
	X9DBL-iF Quick Reference.....	5-11
5-8	Connector Definitions	5-13
5-9	Jumper Settings	5-20
5-10	Onboard Indicators.....	5-22
5-11	SATA Ports	5-23
5-12	Installing Drivers.....	5-24
	SuperDoctor III	5-25
Chapter 6 Advanced Chassis Setup		
6-1	Static-Sensitive Devices.....	6-1
	Precautions	6-1

6-2	Control Panel	6-2
6-3	Accessing the Inside of the System.....	6-3
6-4	System Fans	6-4
6-5	Drive Bay Installation/Removal	6-4
	Removing the Front Bezel	6-4
	Accessing the Drive Bays	6-5
	Hard Drive Installation.....	6-5
	SATA Backplane.....	6-6
	DVD-ROM Drive Installation	6-7
6-6	Power Supply	6-8
	6017B-MTF/6017B-MTLF Power	6-8
	Power Supply Failure.....	6-8
	6017B-MTRF Power	6-9

Chapter 7 BIOS

7-1	Introduction.....	7-1
	Starting BIOS Setup Utility.....	7-1
	How To Change the Configuration Data	7-2
	Starting the Setup Utility	7-2
7-2	Main Setup	7-2
7-3	Advanced Setup Configurations.....	7-4
7-4	Event Logs	7-26
7-5	IPMI.....	7-28
7-6	Boot.....	7-30
7-7	Security	7-31
7-8	Save & Exit	7-32

Appendix A BIOS Error Beep Codes

Appendix B System Specifications

Chapter 1

Introduction

1-1 Overview

The SuperServer 6017B-MTF/6017B-MTLF/6017B-MTRF is a high-end server comprised of two main subsystems: the SC813MTQ-441CB/SC813MTQ-350CB/SC813MTQ-R400CB 1U server chassis and the X9DBL-iF dual processor serverboard. Please refer to our web site for information on operating systems that have been certified for use with the system (www.supermicro.com).

In addition to the serverboard and chassis, various hardware components have been included with the 6017B-MTF/6017B-MTLF/6017B-MTRF, as listed below:

- Four sets of 4-cm counter-rotating fans (FAN-0065L4)
- Two passive CPU heatsinks (SNK-P0037P and SNK-P0041)
- One air shroud for 1U system (MCP-310-19009-0N)
- One riser card for one PCI-E 3.0 x16 add-on card (RSC-RR1U-E16)
- SATA Accessories
 - One SATA backplane (BPN-SAS-815TQ)
 - Four 3.5" hard drive carriers (MCP-220-00075-0B)
 - One SATA cable (CBL-0186L)
 - One SGPIO cable (CBL-0157L)
- One CD containing drivers and utilities
- SuperServer 6017B-MTF/6017B-MTLF/6017B-MTRF User's Manual

Optional

- One rackmount kit (CSE-PT52L)

1-2 Serverboard Features

At the heart of the SuperServer 6017B-MTF/6017B-MTLF/6017B-MTRF lies the X9DBL-iF, a single processor serverboard based on Intel's C602 chipset. Below are the main features of the X9DBL-iF (see Figure 1-1 for a block diagram of the chipset).

Processors

The X9DBL-iF supports up to two Intel® Xeon® E5-2400 Series processors (up to 95W TDP) in LGA 1356 sockets. Please refer to the serverboard description pages on our web site for a complete listing of supported processors.

Memory

The X9DBL-iF has six DIMM sockets that can support up to 192 GB of ECC DDR3-1600/1333/1066/800 R/LRDIMMs (LRDIMM = Reduced Load DIMMs) or up to 48GB of ECC UDIMMs. Please refer to Chapter 5 for installing memory.

SATA

An on-chip SATA controller is integrated into the X9DBL-iF to provide two 6 Gb/sec SATA3 ports and four 3 Gb/sec SATA2 ports, which are RAID 0, 1, 5 and 10 supported.

I/O Ports

The color-coded I/O ports include one COM port, a VGA (monitor) port, two USB 2.0 ports, PS/2 mouse and keyboard ports and two gigabit Ethernet ports. A dedicated IPMI LAN port is also included.

1-3 Server Chassis Features

The following is a general outline of the main features of the SC813MTQ chassis.

System Power

When configured as a SuperServer 6017B-MTF, the SC813MTQ chassis includes a single 440W power supply. The 6017B-MTLF includes a single 350W power supply and the 6017B-MTRF includes a redundant 400W power supply.

Hard Drives

For the 6017B-MTF/6017B-MTLF/6017B-MTRF, the SC813MTQ chassis was designed to support four 3.5" SATA hard drives, which are hot-swappable units.

Control Panel

The SC813MTQ's control panel provides important system monitoring and control information. LEDs indicate power on, network activity, hard disk drive activity and system information. The control panel also includes a main power button and a system reset button. The front of the SC813MTQ also includes a COM port and two USB serial ports for easy access.

Cooling System

The SC813MTQ chassis has an innovative cooling design that features four 4-cm high-performance system cooling fans. Each of these fans plug into a chassis fan header on the serverboard. Fan speed may be determined by IPMI.

**Figure 1-1. Intel C602 Chipset:
System Block Diagram**

Note: This is a general block diagram. Please see Chapter 5 for details.

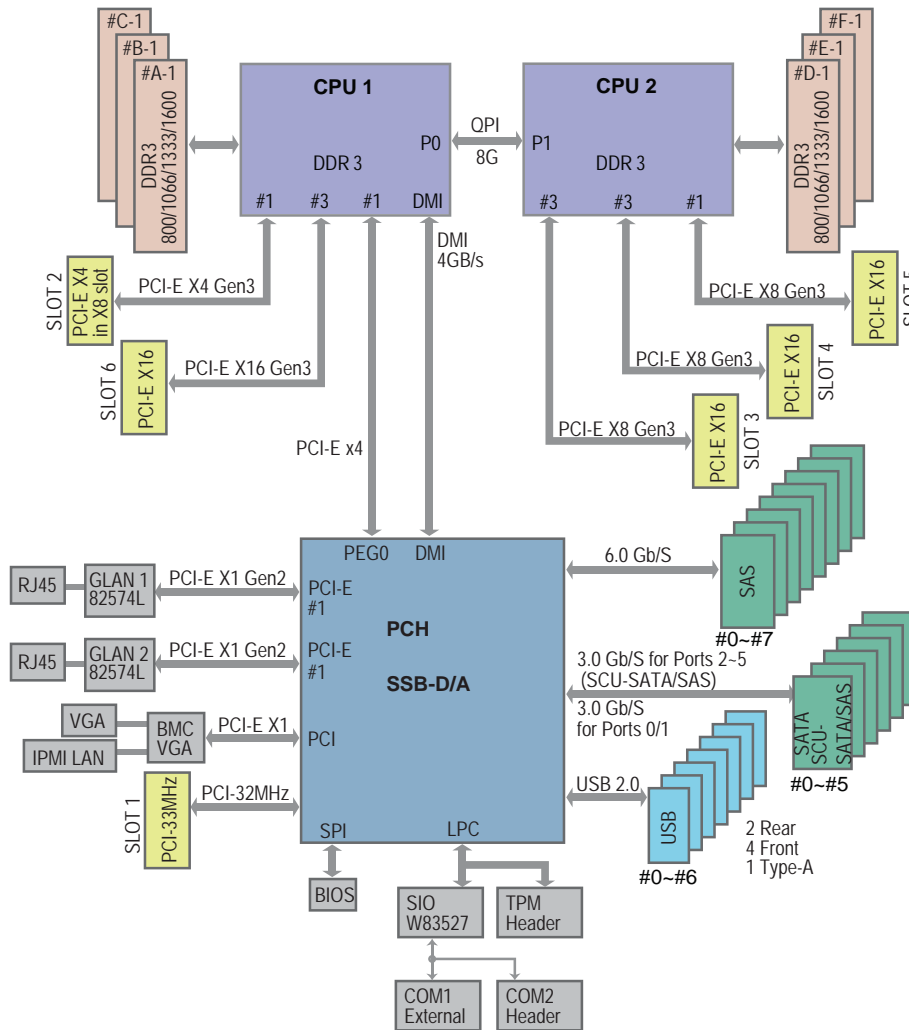

1-4 Contacting Supermicro

Headquarters

Address: Super Micro Computer, Inc.
980 Rock Ave.
San Jose, CA 95131 U.S.A.

Tel: +1 (408) 503-8000

Fax: +1 (408) 503-8008

Email: marketing@supermicro.com (General Information)
support@supermicro.com (Technical Support)

Web Site: www.supermicro.com

Europe

Address: Super Micro Computer B.V.
Het Sterrenbeeld 28, 5215 ML
's-Hertogenbosch, The Netherlands

Tel: +31 (0) 73-6400390

Fax: +31 (0) 73-6416525

Email: sales@supermicro.nl (General Information)
support@supermicro.nl (Technical Support)
rma@supermicro.nl (Customer Support)

Asia-Pacific

Address: Super Micro Computer, Inc.
4F, No. 232-1, Liancheng Rd.
Chung-Ho Dist., New Taipei City 235
Taiwan

Tel: +886-(2) 8226-3990

Fax: +886-(2) 8226-3991

Web Site: www.supermicro.com.tw

Technical Support:

Email: support@supermicro.com.tw

Tel: 886-2-8228-1366, ext.132 or 139

Notes

Chapter 2

Server Installation

2-1 Overview

This chapter provides a quick setup checklist to get your SuperServer 6017B-MTF/6017B-MTLF/6017B-MTRF up and running. Following the steps in the order given should enable you to have the system operational within a minimal amount of time. This quick setup assumes that your 6017B-MTF/6017B-MTLF/6017B-MTRF system has come to you with the processor and memory preinstalled. If your system is not already fully integrated with a motherboard, processor, system memory etc., please turn to the relevant chapter or section.

2-2 Unpacking the System

You should inspect the box the SuperServer 6017B-MTF/6017B-MTLF/6017B-MTRF was shipped in and note if it was damaged in any way. If the server itself shows damage, you should file a damage claim with the carrier who delivered it.

Decide on a suitable location for the rack unit that will hold the SuperServer 6017B-MTF/6017B-MTLF/6017B-MTRF. It should be situated in a clean, dust-free area that is well ventilated. Avoid areas where heat, electrical noise and electromagnetic fields are generated. You will also need it placed near a grounded power outlet. Read the Rack and Server Precautions in the next section.

2-3 Preparing for Setup

The box the SuperServer 6017B-MTF/6017B-MTLF/6017B-MTRF was shipped in should include two sets of rail assemblies, six rail mounting brackets and the mounting screws you will need to install the system into the rack. Follow the steps in the order given to complete the installation process in a minimal amount of time. Please read this section in its entirety before you begin the installation procedure outlined in the sections that follow.

Choosing a Setup Location

- Leave enough clearance in front of the rack to enable you to open the front door completely (~25 inches) and approximately 30 inches of clearance in the back of the rack to allow for sufficient airflow and ease in servicing. This product is for

installation only in a Restricted Access Location (dedicated equipment rooms, service closets and the like).

- This product is not suitable for use with visual display work place devices according to §2 of the the German Ordinance for Work with Visual Display Units.



Warnings and Precautions!



Rack Precautions

- Ensure that the leveling jacks on the bottom of the rack are fully extended to the floor with the full weight of the rack resting on them.
- In single rack installation, stabilizers should be attached to the rack. In multiple rack installations, the racks should be coupled together.
- Always make sure the rack is stable before extending a component from the rack.
- You should extend only one component at a time - extending two or more simultaneously may cause the rack to become unstable.

Server Precautions

- Review the electrical and general safety precautions in Chapter 4.
- Determine the placement of each component in the rack *before* you install the rails.
- Install the heaviest server components on the bottom of the rack first, and then work up.
- Use a regulating uninterruptible power supply (UPS) to protect the server from power surges, voltage spikes and to keep your system operating in case of a power failure.
- Allow the hot plug SATA drives and power supply modules to cool before touching them.
- Always keep the rack's front door and all panels and components on the servers closed when not servicing to maintain proper cooling.

Rack Mounting Considerations

Ambient Operating Temperature

If installed in a closed or multi-unit rack assembly, the ambient operating temperature of the rack environment may be greater than the ambient temperature of the room. Therefore, consideration should be given to installing the equipment in an environment compatible with the manufacturer's maximum rated ambient temperature (T_{mra}).

Reduced Airflow

Equipment should be mounted into a rack so that the amount of airflow required for safe operation is not compromised.

Mechanical Loading

Equipment should be mounted into a rack so that a hazardous condition does not arise due to uneven mechanical loading.

Circuit Overloading

Consideration should be given to the connection of the equipment to the power supply circuitry and the effect that any possible overloading of circuits might have on overcurrent protection and power supply wiring. Appropriate consideration of equipment nameplate ratings should be used when addressing this concern.

Reliable Ground

A reliable ground must be maintained at all times. To ensure this, the rack itself should be grounded. Particular attention should be given to power supply connections other than the direct connections to the branch circuit (i.e. the use of power strips, etc.).

2-4 Installing the System into a Rack

This section provides information on installing the SuperServer 6017B-MTF/6017B-MTLF/6017B-MTRF into a rack unit with the rack rails provided.

There are a variety of rack units on the market, which may mean the assembly procedure will differ slightly. You should also refer to the installation instructions that came with the rack unit you are using.

Identifying the Sections of the Rack Rails

You may have received rack rail hardware with the SuperServer 6017B-MTF/6017B-MTLF/6017B-MTRF. (Two front inner rails should already be attached to the chassis.) This hardware consists of two rear inner rails that secure to the chassis, one on each side just behind the preinstalled front inner rails. Note that these two rails are left/right specific.

Installing the Rear Inner Rails

First, locate the right rear inner rail (the rail that will be used on the right side of the chassis when you face the front of the chassis). Align the two square holes on the rail against the hooks on the right side of the chassis. Securely attach the rail to the chassis with M4 flat head screws. Repeat these steps to install the left rear inner rail to the left side of the chassis (see Figure 2-1). You will also need to attach the rail brackets when installing into a telco rack.

Locking Tabs: Both chassis rails have a locking tab, which serves two functions. The first is to lock the server into place when installed and pushed fully into the rack, which is its normal position. Secondly, these tabs also lock the server in place when fully extended from the rack. This prevents the server from coming completely out of the rack when you pull it out for servicing.

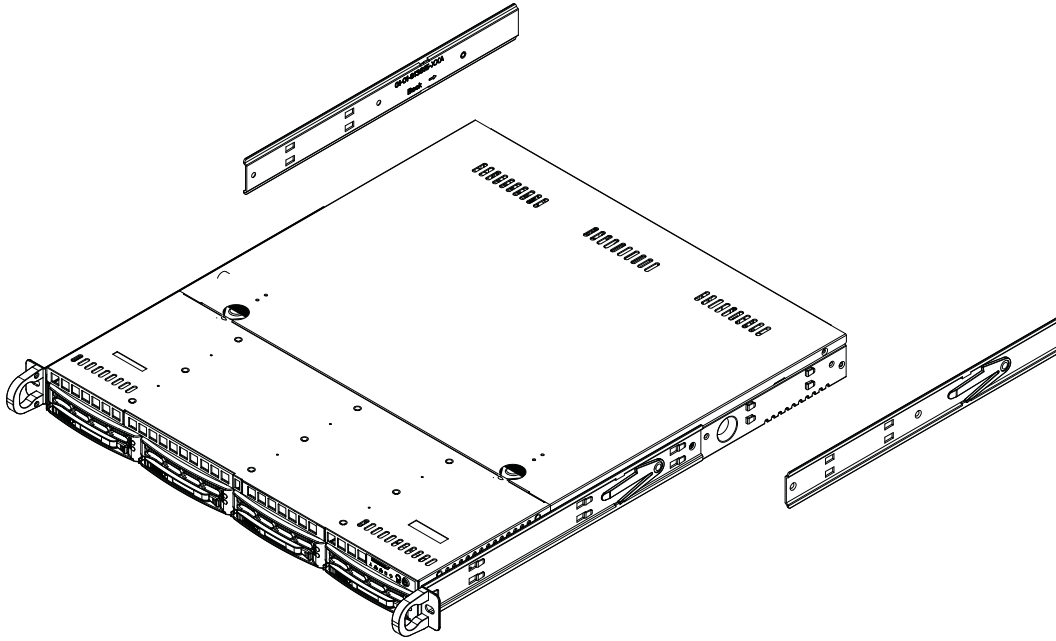
Figure 2-1. Installing Rear Inner Chassis Rails

Installing the Rack Rails

Determine where you want to place the SuperServer 6017B-MTF/6017B-MTLF/6017B-MTRF in the rack ([see Rack and Server Precautions in Section 2-3](#)). Position the chassis rail guides at the desired location in the rack, keeping the sliding rail guide facing the inside of the rack. Screw the assembly securely to the rack using the brackets provided. Attach the other assembly to the other side of the rack, making sure that both are at the exact same height and with the rail guides facing inward.

Installing the Server into the Rack

You should now have rails attached to both the chassis and the rack unit. The next step is to install the server into the rack. Do this by lining up the rear of the chassis rails with the front of the rack rails. Slide the chassis rails into the rack rails, keeping the pressure even on both sides (you may have to depress the locking tabs when inserting). See Figure 2-2.

When the server has been pushed completely into the rack, you should hear the locking tabs "click".

Note: images below are for illustrative purposes only. Always install servers to the bottom of the rack first.

**Figure 2-2. Installing the Server into a Rack
(with optional front bezel shown)**

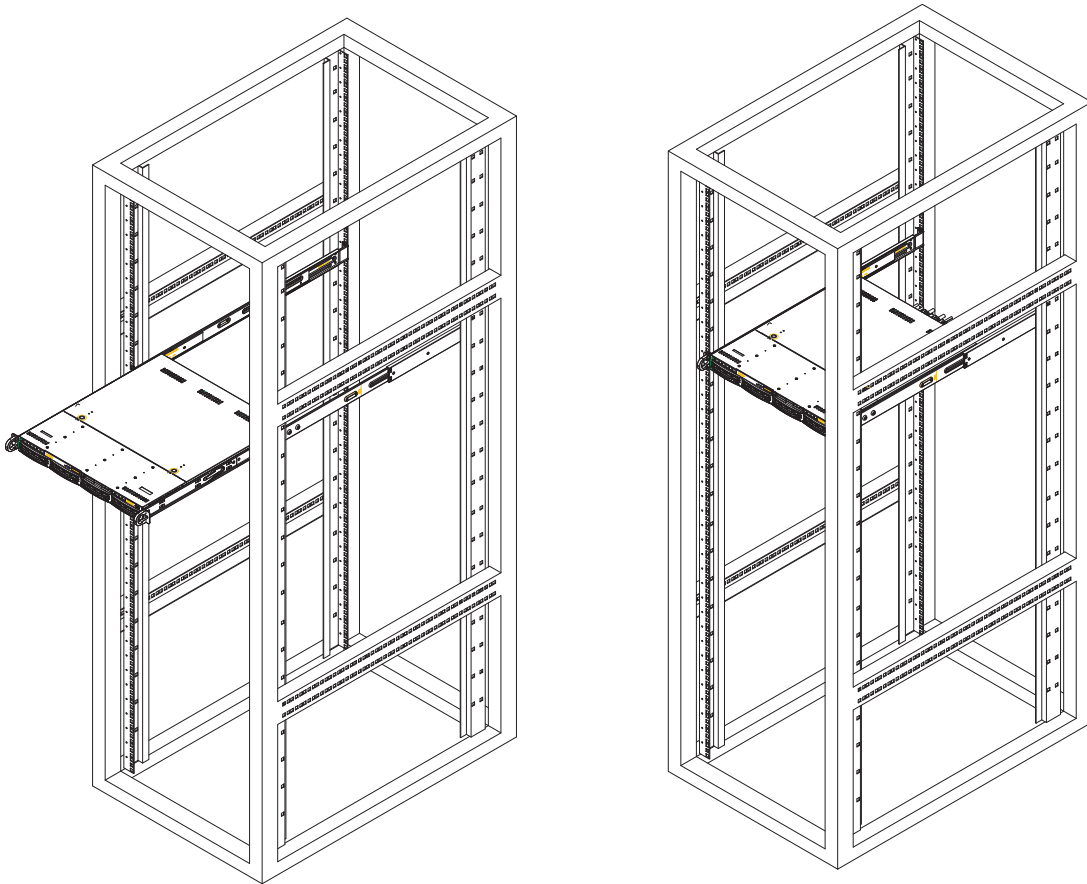

Installing the Server into a Telco Rack

To install the SuperServer 6017B-MTF/6017B-MTLF/6017B-MTRF into a Telco type rack, use two L-shaped brackets on either side of the chassis (four total). First, determine how far the server will extend out the front of the rack. Larger chassis should be positioned to balance the weight between front and back. If a bezel is included on your server, remove it. Then attach the two front brackets to each side of the chassis, then the two rear brackets positioned with just enough space to accommodate the width of the rack. Finish by sliding the chassis into the rack and tightening the brackets to the rack.

**Figure 2-3. Installing the Server into a Telco Rack
(with optional front bezel shown)**

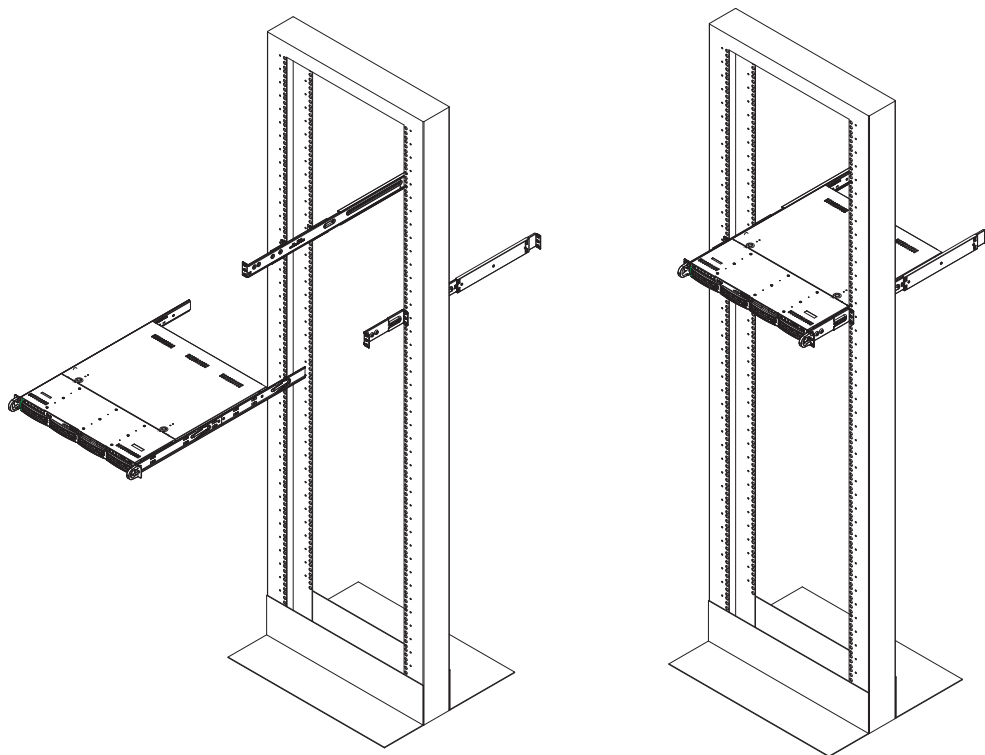

Notes

Chapter 3

System Interface

3-1 Overview

There are several LEDs on the control panel as well as others on the hard drive carriers to keep you constantly informed of the overall status of the system as well as the activity and health of specific components. There are also two buttons on the chassis control panel and an on/off switch on the power supply. This chapter explains the meanings of all LED indicators and the appropriate response you may need to take.

3-2 Control Panel Buttons

There are two push-buttons located on the front of the chassis: a reset button and a power on/off button.



Reset

The reset button reboots the system.



Power

This is the main power button, which is used to apply or turn off the main system power. Turning off system power with this button removes the main power but keeps standby power supplied to the system.

3-3 Control Panel LEDs

The control panel located on the front of the SC813MTQ chassis has five LEDs. These LEDs provide you with critical information related to different parts of the system. This section explains what each LED indicates when illuminated and any corrective action you may need to take.



Information LED

This LED will be solid blue when the UID function has been activated. When this LED flashes red, it indicates a fan failure. When red continuously it indicates an overheat condition, which may be caused by cables obstructing the airflow in the system or the ambient room temperature being too warm. Check the routing of the cables and make sure all fans are present and operating normally. You should also check to make sure that the chassis covers are installed. Finally, verify that the heatsinks are installed properly (see Chapter 5). This LED will remain flashing or on as long as the indicated condition exists.



NIC1

Indicates network activity on LAN1 when flashing.



NIC2

Indicates network activity on LAN2 when flashing.



HDD

Channel activity for all HDDs. This light indicates hard drive activity on the 6017B-MTF/6017B-MTLF/6017B-MTRF when flashing.



Power

Indicates power is being supplied to the system's power supply units. This LED should normally be illuminated when the system is operating.

3-4 Hard Drive Carrier LEDs

Each drive carrier has two LEDs.

- **Green:** When illuminated, the green LED on the drive carrier indicates drive activity. A connection to the backplane enables this LED to blink on and off when that particular drive is being accessed.
- **Red:** The red LED to indicate a drive failure. If one of the drives fails, you should be notified by your system management software. Please refer to Chapter 6 for instructions on replacing failed drives.

Notes

Chapter 4

System Safety

4-1 Electrical Safety Precautions



Basic electrical safety precautions should be followed to protect yourself from harm and the SuperServer 6017B-MTF/6017B-MTLF/6017B-MTRF from damage:

- Be aware of the locations of the power on/off switch on the chassis as well as the room's emergency power-off switch, disconnection switch or electrical outlet. If an electrical accident occurs, you can then quickly remove power from the system.
- Do not work alone when working with high voltage components.
- Power should always be disconnected from the system when removing or installing main system components, such as the serverboard, DVD drive and memory modules. When disconnecting power, you should first power down the system with the operating system first and then unplug the power cords of all the power supply units in the system.
- When working around exposed electrical circuits, another person who is familiar with the power-off controls should be nearby to switch off the power if necessary.
- Use only one hand when working with powered-on electrical equipment. This is to avoid making a complete circuit, which will cause electrical shock. Use extreme caution when using metal tools, which can easily damage any electrical components or circuit boards they come into contact with.
- Do not use mats designed to decrease static electrical discharge as protection from electrical shock. Instead, use rubber mats that have been specifically designed as electrical insulators.
- The power supply power cords must include a grounding plug and must be plugged into grounded electrical outlets.

- This product may be connected to an IT power system. In all cases, make sure that the unit is also reliably connected to Earth (ground).
- Serverboard Battery: **CAUTION** - There is a danger of explosion if the onboard battery is installed upside down, which will reverse its polarities (see Figure 4-1). This battery must be replaced only with the same or an equivalent type recommended by the manufacturer (CR2032). Dispose of used batteries according to the manufacturer's instructions.
- DVD-ROM Laser: **CAUTION** - this server may have come equipped with a DVD-ROM drive. To prevent direct exposure to the laser beam and hazardous radiation exposure, do not open the enclosure or use the unit in any unconventional way.
- Mainboard replaceable soldered-in fuses: Self-resetting PTC (Positive Temperature Coefficient) fuses on the mainboard must be replaced by trained service technicians only. The new fuse must be the same or equivalent as the one replaced. Contact technical support for details and support.

4-2 General Safety Precautions



Follow these rules to ensure general safety:

- Keep the area around the 6017B-MTF/6017B-MTLF/6017B-MTRF clean and free of clutter.
- The 6017B-MTF/6017B-MTLF/6017B-MTRF weighs approximately 38 lbs (~17.3 kg) when fully loaded. When lifting the system, two people at either end should lift slowly with their feet spread out to distribute the weight. Always keep your back straight and lift with your legs.
- Place the chassis top cover and any system components that have been removed away from the system or on a table so that they won't accidentally be stepped on.
- While working on the system, do not wear loose clothing such as neckties and unbuttoned shirt sleeves, which can come into contact with electrical circuits or be pulled into a cooling fan.

- Remove any jewelry or metal objects from your body, which are excellent metal conductors that can create short circuits and harm you if they come into contact with printed circuit boards or areas where power is present.
- After accessing the inside of the system, close the system back up and secure it to the rack unit with the retention screws after ensuring that all connections have been made.

4-3 ESD Precautions



Electrostatic Discharge (ESD) is generated by two objects with different electrical charges coming into contact with each other. An electrical discharge is created to neutralize this difference, which can damage electronic components and printed circuit boards. The following measures are generally sufficient to neutralize this difference before contact is made to protect your equipment from ESD:

- Use a grounded wrist strap designed to prevent static discharge.
- Keep all components and printed circuit boards (PCBs) in their antistatic bags until ready for use.
- Touch a grounded metal object before removing the board from the antistatic bag.
- Do not let components or PCBs come into contact with your clothing, which may retain a charge even if you are wearing a wrist strap.
- Handle a board by its edges only; do not touch its components, peripheral chips, memory modules or contacts.
- When handling chips or modules, avoid touching their pins.
- Put the serverboard and peripherals back into their antistatic bags when not in use.
- For grounding purposes, make sure your computer chassis provides excellent conductivity between the power supply, the case, the mounting fasteners and the serverboard.

4-4 Operating Precautions



Care must be taken to assure that the chassis cover is in place when the 6017B-MTF/6017B-MTLF/6017B-MTRF is operating to assure proper cooling. Out of warranty damage to the system can occur if this practice is not strictly followed.

Figure 4-1. Installing the Onboard Battery

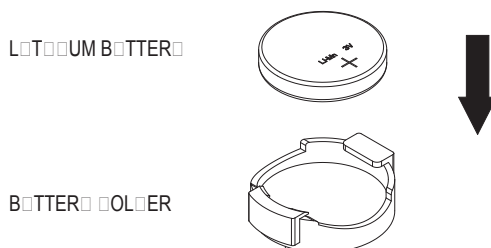

Please handle used batteries carefully. Do not damage the battery in any way; a damaged battery may release hazardous materials into the environment. Do not discard a used battery in the garbage or a public landfill. Please comply with the regulations set up by your local hazardous waste management agency to dispose of your used battery properly.

Chapter 5

Advanced Serverboard Setup

This chapter covers the steps required to install processors and heatsinks to the X9DBL-iF serverboard, connect the data and power cables and install add-on cards. All serverboard jumpers and connections are described and a layout and quick reference chart are included in this chapter. Remember to close the chassis completely when you have finished working on the serverboard to protect and cool the system sufficiently.

5-1 Handling the Serverboard

Static electrical discharge can damage electronic components. To prevent damage to printed circuit boards, it is important to handle them very carefully (see Chapter 4). Also note that the size and weight of the serverboard can cause it to bend if handled improperly, which may result in damage. To prevent the serverboard from bending, keep one hand under the center of the board to support it when handling. The following measures are generally sufficient to protect your equipment from static discharge.

Precautions

- Use a grounded wrist strap designed to prevent static discharge.
- Touch a grounded metal object before removing any board from its antistatic bag.
- Handle a board by its edges only; do not touch its components, peripheral chips, memory modules or gold contacts.
- When handling chips or modules, avoid touching their pins.
- Put the serverboard, add-on cards and peripherals back into their antistatic bags when not in use.

Unpacking

The serverboard is shipped in antistatic packaging to avoid static damage. When unpacking the board, make sure the person handling it is static protected.

5-2 Processor and Heatsink Installation



When handling the processor package, avoid placing direct pressure on the label area of the fan.

Notes:

- Always connect the power cord last and always remove it before adding, removing or changing any hardware components. Make sure that you install the processor into the CPU socket before you install the CPU heatsink.
- If you buy a CPU separately, make sure that you use an Intel-certified multi-directional heatsink only.
- Make sure to install the serverboard into the chassis before you install the CPU heatsinks.
- When receiving a serverboard without a processor pre-installed, make sure that the plastic CPU socket cap is in place and none of the socket pins are bent; otherwise, contact your retailer immediately.
- Refer to the Supermicro web site for updates on CPU support.

Installing an LGA 1356 Processor

1. Press the socket clip to release the load plate covering the CPU socket from its locked position.
2. Gently lift the socket clip to open the load plate.
3. Hold the plastic cap at its north and south center edges to remove it from the CPU socket.
4. After removing the plastic cap, hold the CPU at the north and south center edges with your thumb and index finger,.

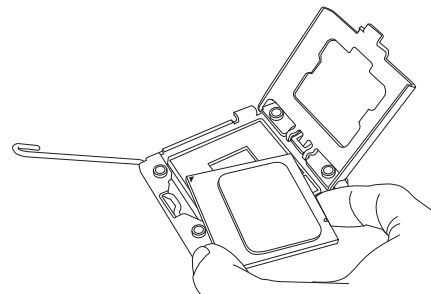
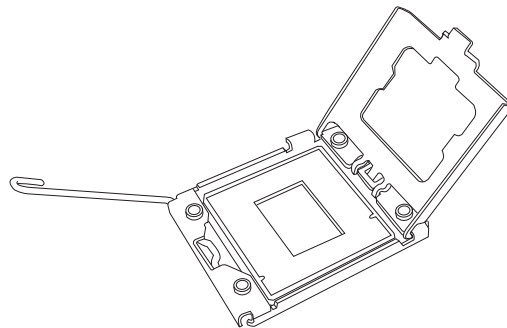

5. Align the CPU key, which is a semi-circle cutout, against the socket key, which is the notch below the gold color dot on the side of the socket.
6. Align pin 1 of the CPU against pin 1 of the CPU socket.
7. Once both CPU and the socket are aligned, carefully lower the CPU straight down into the socket. (To avoid damaging the CPU or the socket, do not rub the CPU against the surface of the socket or its pins.)
8. With the CPU inside the socket, inspect the four corners of the CPU to make sure that the CPU is properly installed.
9. Once the CPU is securely seated on the socket, lower the CPU load plate to the socket.
10. Use your thumb to gently push the socket clip down to the clip lock.

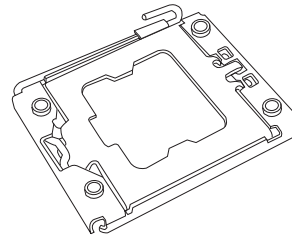
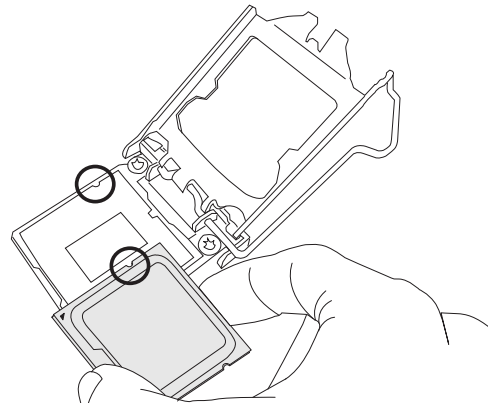

Warning: Please save the plastic cap. The serverboard must be shipped with the plastic cap properly installed to protect the CPU socket pins. Shipment without the plastic cap properly installed will cause damage to the socket pins.

Installing a CPU Heatsink

1. Remove power from the system and unplug the AC power cord from the power supply.
2. Do not apply any thermal grease to the heatsink or the CPU die; the required amount has already been applied.
3. Place the heatsink on top of the CPU so that the four mounting holes are aligned with those on the (preinstalled) heatsink retention mechanism.
4. Screw in two diagonal screws (i.e. the #1 and the #2 screws) until just snug. Do not fully tighten the screws or you may damage the CPU.)
5. Add the two remaining screws then finish the installation by fully tightening all four screws.

Figure 5-1. Installing/Removing the Heatsink

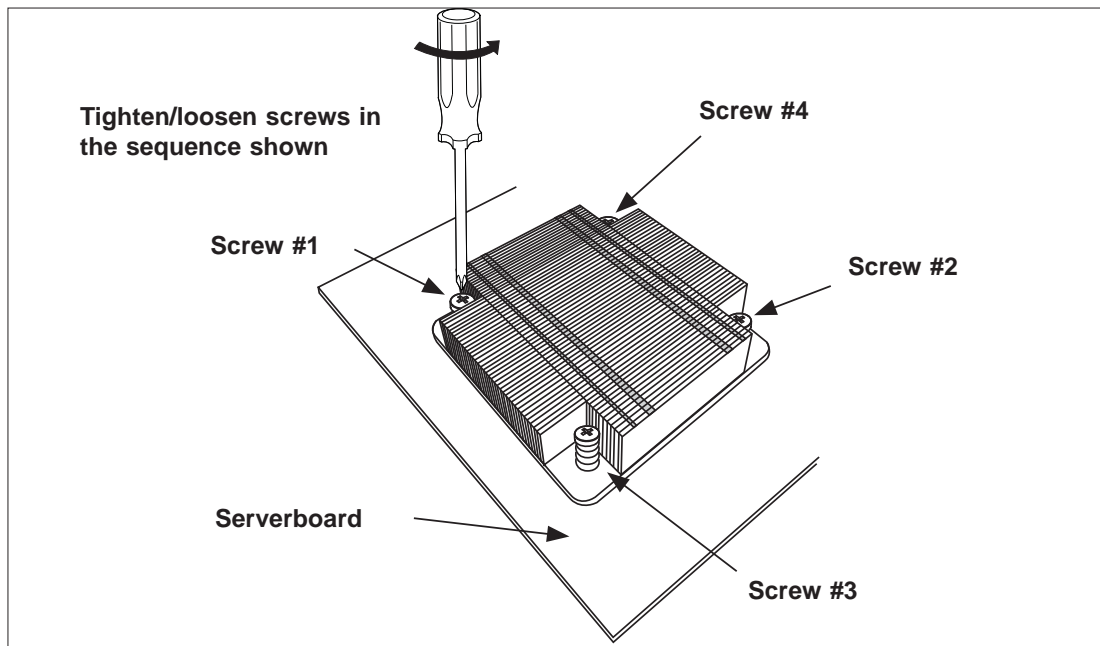

5-3 Connecting Cables

Now that the processors are installed, the next step is to connect the cables to the serverboard. These include the data (ribbon) cables for the peripherals and control panel and the power cables.

Connecting Data Cables

The cables used to transfer data from the peripheral devices have been carefully routed in preconfigured systems to prevent them from blocking the flow of cooling air that moves through the system from front to back. If you need to disconnect any of these cables, you should take care to reroute them as they were originally after reconnecting them (make sure the red wires connect to the pin 1 locations). If you are configuring the system, keep the airflow in mind when routing the cables.

The following data cables (with their serverboard connector locations noted) should be connected.

See the serverboard layout diagram in this chapter for connector locations.

- Control Panel cable (JF1, see next page)
- SATA cables (I-SATA0 ~ I-SATA3)
- SGPIO cable (T-SGPIO1 to SATA backplane)

Connecting Power Cables

The X9DBL-iF has a 24-pin primary power supply connector designated "JPW1" for connection to the ATX power supply. Connect the appropriate connector from the power supply to JPW1 to supply power to the serverboard. See the Connector Definitions section in this chapter for power connector pin definitions.

In addition, your power supply must be connected to the 8-pin Processor Power connectors at JPW2 and JPW3.

Connecting the Control Panel

JF1 contains header pins for various front control panel connectors. See Figure 5-2 for the pin locations of the various front control panel buttons and LED indicators. Please note that even and odd numbered pins are on opposite sides of each header.

All JF1 wires have been bundled into single keyed ribbon cable to simplify their connection. Connect one end of this cable to JF1 and the other end to the Control Panel printed circuit board, located just behind the system status LEDs in the chassis.

See the Connector Definitions section in this chapter for details and pin descriptions of JF1.

Figure 5-2. Front Control Panel Header Pins (JF1)

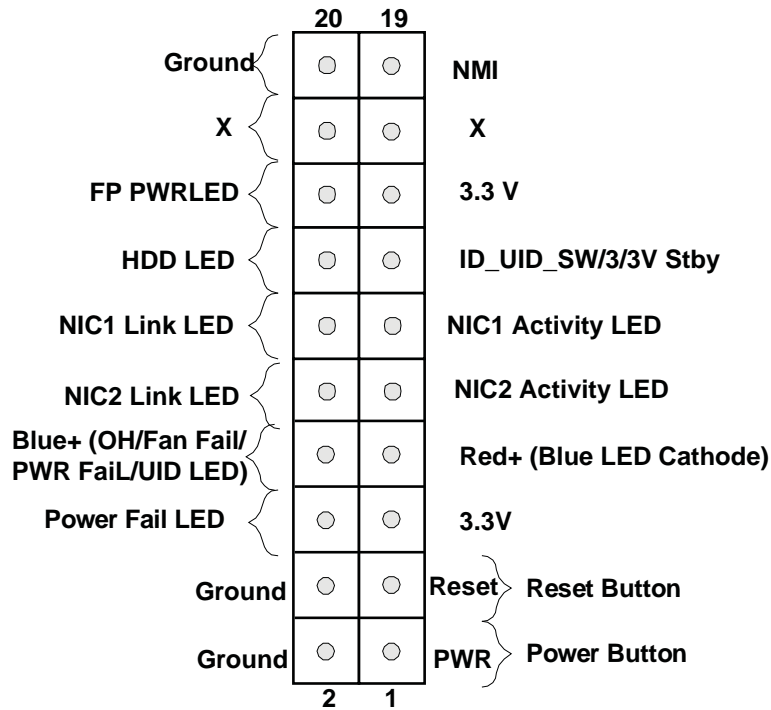

5-4 I/O Ports

The I/O ports are color coded in conformance with the PC 99 specification. See Figure 5-3 below for the colors and locations of the various I/O ports.

Figure 5-3. Rear Panel I/O Ports

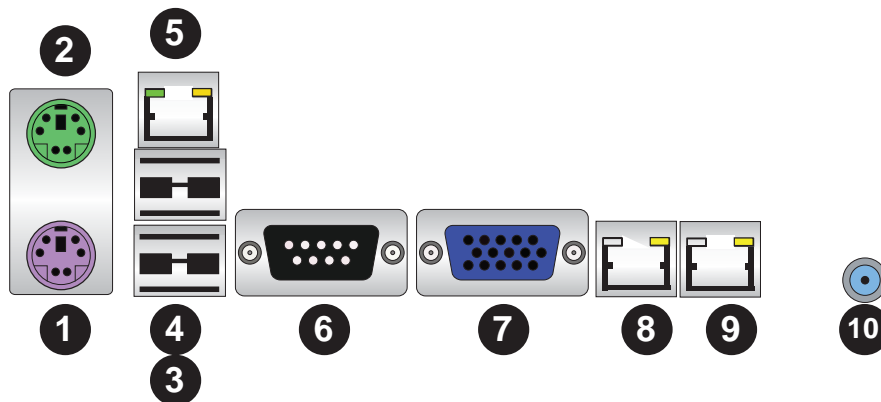

I/O Ports	
1. Keyboard (Purple)	6. COM1
2. PS/2 Mouse (Green)	7. VGA
3. USB Port 0	8. LAN1
4. USB Port 1	9. LAN2
5. IPMI LAN	10. UID Switch

5-5 Installing Memory

Note: Check the Supermicro web site for recommended memory modules.

CAUTION

Exercise extreme care when installing or removing DIMM modules to prevent any possible damage.

Installing DIMMs

Insert the desired number of DIMMs into the memory slots, starting with slot P1-DIMM#1A.

1. Push the release tabs outwards on both ends of the DIMM slot to unlock it.
2. Align the key on the DIMM module with the receptive point on the slot.
3. Use two thumbs together to press both ends of the module straight down into the slot until the module snaps into place.
4. Press the release tabs to the lock positions to secure the DIMM module into the slot. See Figure 5-4.

Memory Support

The X9DBL-iF supports up to 192 GB of ECC DDR3-1600/1333/1066/800 RDIMMs/LRDIMMs (RDIMM = Registered DIMMs, LRDIMM = Reduced Load DIMMs) or up to 48GB of ECC UDIMMs (Unregistered DIMMs).

Figure 5-4. Installing DIMM into Slot

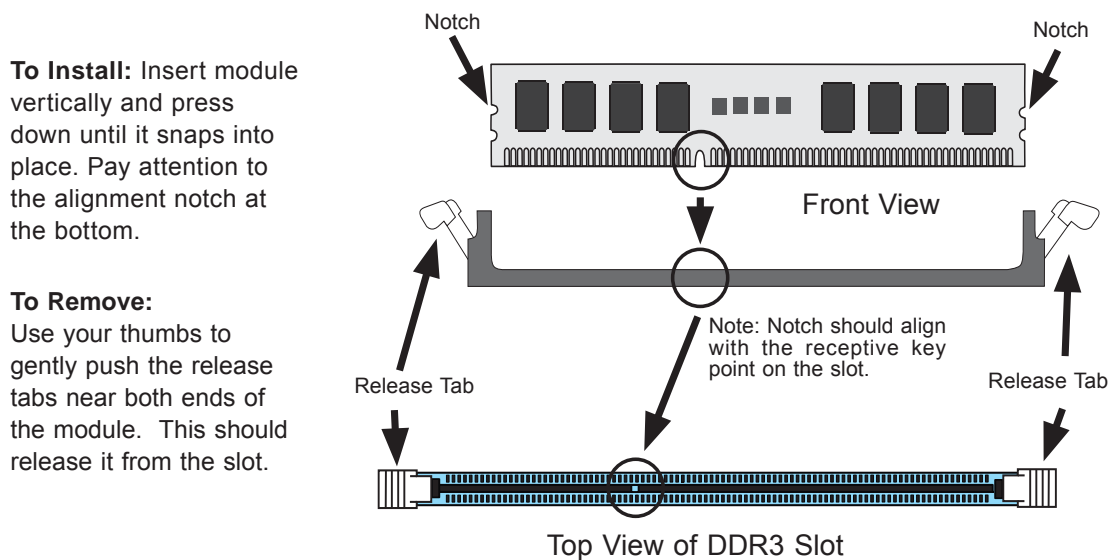

Processor & Memory Module Population Configuration

For memory to work properly, follow the tables below for memory installation.

Processors and their Corresponding Memory Modules			
CPU#	Corresponding DIMM Modules		
CPU 1	P1-DIMM1A	P1-DIMM1B	P1-DIMM1C
CPU2	P2-DIMM1D	P2-DIMM1E	P2-DIMM1F

Processor and Memory Module Population	
Number of CPUs+DIMMs	CPU and Memory Population Configuration Table (For memory to work proper, please install according to the charts below)
1 CPU & 1 DIMMs	CPU1 P1-DIMM1A
1 CPU & 2 DIMMs	CPU1 P1-DIMM1A, P1-DIMM1B
1 CPU & 3 DIMMs	CPU1 P1-DIMM1A, P1-DIMM1B, P1-DIMM1C
2 CPUs & 2 DIMMs	CPU1 + CPU2 P1-DIMM1A, P2-DIMM1D
2 CPUs & 3 DIMMs	CPU1 + CPU2 P1-DIMM1A, P2-DIMM1D, P1-DIMM1B
2 CPUs & 4 DIMMs	CPU1 + CPU2 P1-DIMM1A, P2-DIMM1D, P1-DIMM1B, P2-DIMM1E
2 CPUs & 5 DIMMs	CPU1 + CPU2 P1-DIMM1A, P2-DIMM1D, P1-DIMM1B, P2-DIMM1E, P1-DIMM1C
2 CPUs & 6 DIMMs	CPU1 + CPU2 P1-DIMM1A, P2-DIMM1D, P1-DIMM1B, P2-DIMM1E, P1-DIMM1C, P2-DIMM1F

Populating UDIMM ECC-Non ECC Memory Modules

Intel E5-2400 Series Processor UDIMM Memory Support					
Ranks Per DIMM & Data Width	Memory Capacity Per DIMM (See the Note below)			1 Slot per Channel	
				1DPC	
	1.35V	1.5V			
SRx8 Non-ECC	1GB	2GB	4GB	NA	1066, 1333
DRx8 Non-ECC	2GB	4GB	8GB	NA	1066, 1333
SRx16 Non-ECC	512MB	1GB	2GB	NA	1066, 1333
SRx8 ECC	1GB	2GB	4GB	1066,1333	1066, 1333
DRx8 ECC	2GB	4GB	8GB	1066, 1333	1066, 1333

Note: For detailed information on memory support and updates, please refer to the SMC Recommended Memory List posted on our website at <http://www.supermicro.com/support/resources/mem.cfm>.

Populating RDIMM ECC Memory Modules

Intel E5-2400 Series Processor RDIMM Memory Support					
Ranks Per DIMM & Data Width	Memory Capacity Per DIMM (See the Note Below)			1 Slot Per Channel	
				1DPC	
				1.35V	1.5V
SRx8	1GB	2GB	4GB	1066, 1333	1066, 1333, 1600
DRx8	2GB	4GB	8GB	1066, 1333	1066, 1333, 1600
SRx4	2GB	4GB	8GB	1066, 1333	1066, 1333, 1600
DRx4	4GB	8GB	16GB	1066, 1333	1066, 1333, 1600
QRx4	8GB	16GB	32GB	800	800
QRx8	4GB	8GB	16GB	800	800

Note: For detailed information on memory support and updates, please refer to the SMC Recommended Memory List posted on our website at <http://www.supermicro.com/support/resources/mem.cfm>.

Populating LRDIMM ECC Memory Modules

Intel E5-2400 Series Processor LRDIMM Memory Support				
Ranks Per DIMM & Data Width	Memory Capacity Per DIMM (See the Note Below)		1 Slot Per Channel	
			1DPC	
			1.35V	1.5V
QRx4 (DDP)	16GB	32GB	1066	1066, 1333
QRx8 (P)	8GB	16GB	1066	1066, 1333

Note: For detailed information on memory support and updates, please refer to the SMC Recommended Memory List posted on our website at <http://www.supermicro.com/support/resources/mem.cfm>.

Other Important Notes and Restrictions

- For the memory modules to work properly, please install DIMM modules of the same type, same speed and same operating frequency on the serverboard. Mixing of RDIMMs, UDIMMs or LRDIMMs is not allowed. Do not install both ECC and Non-ECC memory modules on the same serverboard.
- Using DDR3 DIMMs with different operating frequencies is not allowed. All channels in a system will run at the lowest common frequency.

5-6 Adding PCI Cards

PCI Expansion Slots

One riser card is used to support a PCI expansion (add-on) card in the system. The SC813MTQ chassis can accommodate one standard size (full height full length) PCI expansion card. When viewed from the chassis front, the card installs to the left rear of the system.

PCI Card Installation

Before installing a PCI add-on card, make sure it is supported by the riser card. Begin by releasing the locking tab that corresponds to the slot you wish to populate. Insert the expansion card into the riser card by pushing down with your thumbs evenly on both sides of the card.

PCI Slot/Card Configurations

Riser Card

RSC-RR1U-E16 (pre-installed)

Expansion card supported

1x PCI-E 3.0/2.0 x16 card

5-7 Serverboard Details

Figure 5-5. SUPER X9DBL-iF Layout

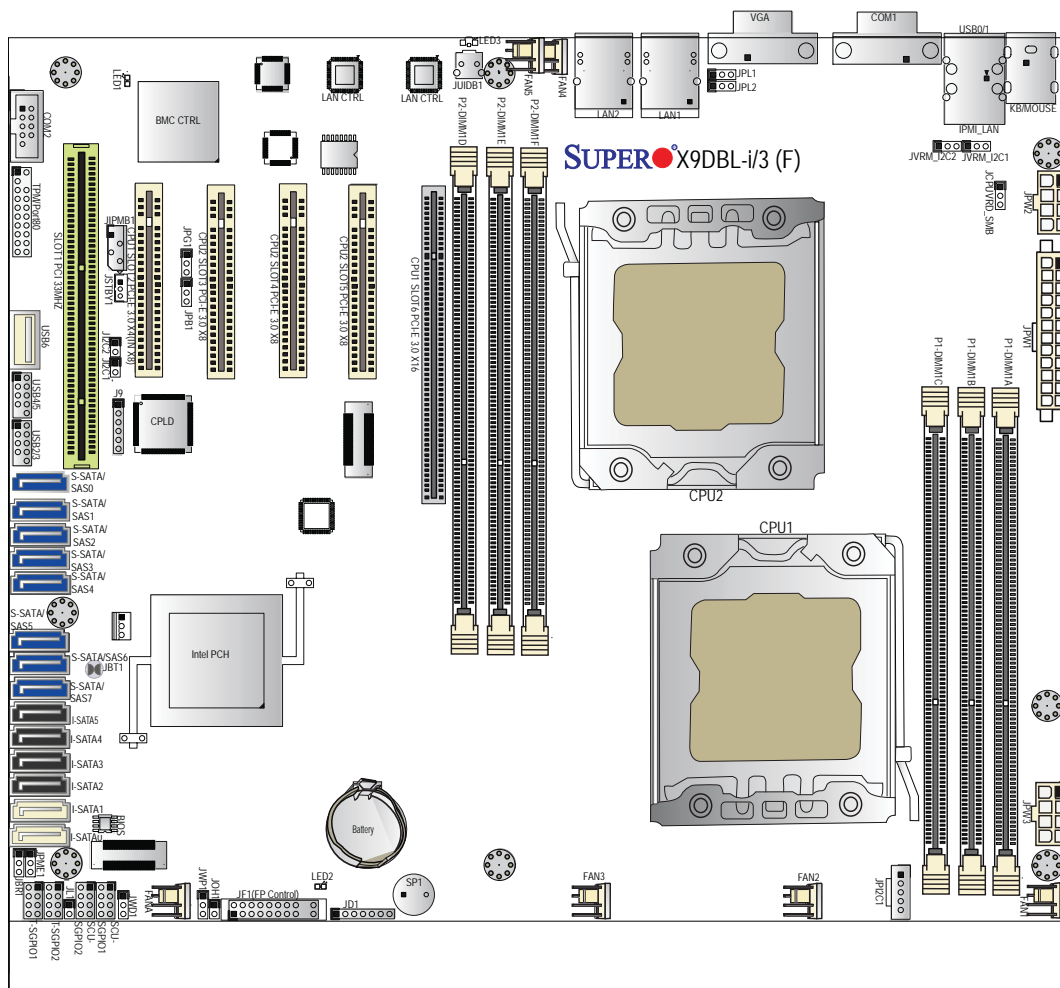

X9DBL-iF Quick Reference

Jumper	Description	Default Setting
JBT1	Clear CMOS	See Section 5-9
JI ² C1/JI ² C2	SMB to PCI-E Slots	Pins Open (Normal)
JPB1	BMC Enable	Pins 1-2 (Enabled)
JPG1	VGA Enable	Pins 1-2 (Enabled)
JPL1/JPL2	LAN1/LAN2 Enable	Pins 1-2 (Enabled)
JVRM_I ² C1/JVRM_I ² C2	I ² C Bus to CPU1/CPU2 VRMs	Pins 1-2 (Enabled)
JWD1	Watch Dog	Pins 1-2 (Reset)
LED	Description	State: Status
LED1	BMC Heartbeat LED	Blinking Green: Normal
LED2	Standby PWR LED	Green: Standby Power On
LED3	UID LED	Solid/Blinking Blue: Unit ID (Windows/Linux)

Connector	Description
COM1/COM2	Backplane COM Port1/Front Accessible COM2 Header
FAN1~5, FANA	CPU/System Fan Headers
I-SATA 0~5	Intel PCH SATA Ports 0~5 (I-SATA 0/1 are SATA 3.0 ports)
JD1	Power LED/Speaker (PWR LED Pins 1~3, Speaker: Pins 4~7)
JF1	Control Panel Header
JIPMB1	4-pin External BMC I ² C Header (for an IPMI Card)
JL1	Chassis Intrusion
JOH1	Overheat/Fan Fail LED
JPI ² C1	Power Supply SMBbus I ² C Header
JPW1	ATX 24-Pin Power Connector
JPW2~JPW3	12V 8-Pin Power Connectors
JSTBY1	Standby Power Header
JTPM1	TPM (Trusted Platform Module)/Port 80
LAN1/2	Gb Ethernet Ports 1/2
(IPMI) LAN	Dedicated IPMI LAN Port
Slot1	PCI 133 MHz Slot
(CPU2) Slot3/4/5	PCI-Exp. 3.0 x8 Slots
(CPU 1) Slot2	PCI-Exp. 3.0 x4 in x8 Slot
(CPU 1) Slot6	PCI-Exp. 3.0 x4 in x16 Slot
SCU-SGPIO 1	Serial Link General Purpose I/O Connector 1 for SCU-SATA/SAS 0~3 (from SCU)
T-SGPIO 1	Serial Link General Purpose I/O Connector 1 for I-SATA 0~5
T-SGPIO 2	Serial Link General Purpose I/O Connector 1 for I-SATA 4/5
TPM/Port 80	TPM (Trusted Platform Module)/Port 80 Connection (JTPM)
USB 0/1	Back Panel USB 0/1 Ports
USB 2/3, 4/5	Front Panel Accessible USB 2/3, 4/5 Connections
USB 6	Front Panel Type A USB 6 Port
UID Switch	UID (Unit Identifier) Switch

Notes

PCI slots are enabled with installed processors. If only a single CPU is installed, some PCI slots will not be enabled. See table above to determine which PCI slots are controlled by which CPU.

The X9DBL-iF shares the same layout with the X9DBL-3F but without SAS ports and components.

5-8 Connector Definitions

Power Connectors

The 24-pin main power connector (JPW1) is used to provide power to the serverboard. The 8-pin CPU PWR connectors (JPW2/JPW3) are also required for the processor. These power connectors meet the SSI EPS 12V specification. See the tables on the right for pin definitions.

ATX Power 24-pin Connector Pin Definitions (JPW1)			
Pin#	Definition	Pin #	Definition
13	+3.3V	1	+3.3V
14	-12V	2	+3.3V
15	COM	3	COM
16	PS_ON	4	+5V
17	COM	5	COM
18	COM	6	+5V
19	COM	7	COM
20	Res (NC)	8	PWR_OK
21	+5V	9	5VSB
22	+5V	10	+12V
23	+5V	11	+12V
24	COM	12	+3.3V

Processor Power Pin Definitions (JPW2/JPW3)	
Pins	Definition
1 through 4	Ground
5 through 8	+12V

NMI Button

The non-maskable interrupt button header is located on pins 19 and 20 of JF1. Refer to the table on the right for pin definitions.

NMI Button Pin Definitions (JF1)	
Pin#	Definition
19	Control
20	Ground

Power LED

The Power LED connection is located on pins 15 and 16 of JF1. Refer to the table on the right for pin definitions.

Power LED Pin Definitions (JF1)	
Pin#	Definition
15	+5V
16	Ground

HDD LED

The HDD LED connections are located on pins 13 and 14 of JF1. Attach a cable here to indicate HDD activity. See the table on the right for pin definitions.

HDD LED Pin Definitions (JF1)	
Pin#	Definition
13	+5V
14	HD Active

NIC1/NIC2 (LAN1/LAN2)

The NIC (Network Interface Controller) LED connection for LAN port 1 is located on pins 11 and 12 of JF1, and the LED connection for LAN Port 2 is on Pins 9 and 10. NIC1 LED and NIC2 LED are 2-pin NIC LED headers. Attach NIC LED cables to NIC1 LED and NIC2 LED to display network activities for LAN 1 and LAN2. Refer to the table on the right for pin definitions.

LAN1/LAN2 LED Pin Definitions (JF1)	
Pin#	Definition
9/11	Vcc
10/12	Ground

Overheat (OH)/Fan Fail/Front UID LED

Connect an LED cable to the Front UID and OH/Fan Fail connections on pins 7 and 8 of JF1. The red LED on pin 7 provides warnings of overheat, fan failure or power failure. The blue LED on pin 8 works as the front panel UID LED indicator. The red LED takes precedence over the blue LED by default. Refer to the table on the right for pin definitions.

OH/Fan Fail/ PWR Fail/Blue_UID LED Pin Definitions (JF1)	
Pin#	Definition
7	Red_LED-Cathode/OH/Fan Fail/Power Fail5.5V.SB
8	Blue_UID LED

OH/Fan Fail Indicator Status	
State	Definition
Off	Normal
On	Overheat
Flashing	Fan Fail

Reset Button

The Reset Button connection is located on pins 3 and 4 of JF1. Attach it to a the hardware Reset Button on the computer case. Refer to the table on the right for pin definitions.

Reset Button Pin Definitions (JF1)	
Pin#	Definition
3	Reset
4	Ground

Power Fail LED

The Power Fail LED connection is located on pins 5 and 6 of JF1. Refer to the table on the right for pin definitions.

PWR Fail LED Pin Definitions (JF1)	
Pin#	Definition
5	Vcc
6	Ground

Power Button

The Power Button connection is located on pins 1 and 2 of JF1. Momentarily contacting both pins will power on/off the system. This button can also be configured to function as a suspend button (see BIOS Setup). To turn off the power in the suspend mode, press the button for at least 4 seconds. Refer to the table on the right for pin definitions.

Power Button Pin Definitions (JF1)	
Pin#	Definition
1	Signal
2	+3V Standby

Universal Serial Bus (USB)

Two Universal Serial Bus ports (USB 0/1) are located on the I/O backpanel and an additional four USB ports on two headers, USB2/3, 4/5, provide front chassis access. USB 6 is a Type A USB connector. (USB cables are not included). See the tables on the right for pin definitions.

Back Panel USB0/1 Pin Definitions			
Pin#	Definition	Pin#	Definition
1	+5V	5	+5V
2	USB_PN1	6	USB_PN0
3	USB_PP1	7	USB_PP0
4	Ground	8	Ground

Front Accessible USB2/3, 4/5, 6 Pin Definitions			
USB 2/4/11/12		USB 3/5/13	
Pin #	Definition	Pin #	Definition
1	+5V	6	+5V
2	PO-	7	PO-
3	PO+	8	PO+
4	Ground	9	Ground
5	No Connection	10	Key

Serial Ports

The COM1 port is located on the I/O backpanel. COM2 is a header located on the the serverboard. See the table on the right for pin definitions.

Serial Port Pin Definitions (COM1/COM2)			
Pin #	Definition	Pin #	Definition
1	CDC	6	DSR
2	RXD	7	RTS
3	TXD	8	CTS
4	DTR	9	RI
5	Ground	10	NC

Fan Headers

The X9DBL-iF has six fan headers (Fan1 ~ Fan5 and FanA). These are all 4-pin fan headers, however pins 1-3 are backward compatible with traditional 3-pin fans. Fan speed is controlled via IPMI based on the system temperature. Refer to the table on the right for pin definitions.

Note: Please use all 3-pin fans or all 4-pin fans. Do not mix 3-pin fans and 4-pin fans on the same board.

Fan Header Pin Definitions	
Pin#	Definition
1	Ground (Black)
2	+12V (Red)
3	Tachometer
4	PWM_Control

Chassis Intrusion

A Chassis Intrusion header is located at JL1 on the serverboard. Attach the appropriate cable from the chassis to inform you of a chassis intrusion when the chassis is opened.

Chassis Intrusion Pin Definitions	
Pin#	Definition
1	Intrusion Input
2	Ground

ATX PS/2 Keyboard and PS/2 Mouse Ports

The ATX PS/2 keyboard and the PS/2 mouse ports are located on the I/O back-plane. See the table on the right for pin definitions.

PS/2 Keyboard and Mouse Ports Pin Definitions	
Pin#	Definition
1	Data
2	NC
3	Ground
4	+5 VCC
5	Clock
6	NC

Speaker (JD1)

On the JD1 header, Pins 6~7 are used for the internal speaker. Close Pins 6~7 with a jumper or cap to use the onboard speaker. If you wish to use an external speaker, attach the external speaker's cable to Pins 1~4. See the table on the right for pin definitions.

Speaker Connector Pin Definitions	
Pin Setting	Definition
Pins 6~7	Internal Speaker
Pins 1~3	PWR LED
Pins 4~7	External Speaker

Trusted Platform Module Header

This header is used to connect a Trusted Platform Module (TPM), available separately from a third-party vendor. A TPM is a security device that allows encryption and authentication of hard drives, disallowing access if the TPM associated with it is not installed in the system. See the table on the right for pin definitions.

Trusted Platform Module Header Pin Definitions			
Pin #	Definition	Pin #	Definition
1	LCLK	2	GND
3	LFRAME	4	No Pin
5	LRESET	6	VCC5
7	LAD3	8	LAD2
9	VCC3	10	LAD1
11	LAD0	12	GND
13	RSV0	14	RSV1
15	SB3V	16	SERIRQ
17	GND	18	CLKRUN
19	LPCPD	20	RSV2

IPMB

A System Management Bus header for IPMI 2.0 is located at JIPMB1. Connect the appropriate cable here to use the IPMB I²C connection on your system.

IPMB Header Pin Definitions	
Pin#	Definition
1	Data
2	Ground
3	Clock
4	No Connection

Power Supply I²C Connector

The Power Supply (I²C) connector is located at JPI²C1 on the serverboard. This connector monitors the status of the power supply, fan and system temperature. See the table on the right for pin definitions.

PWR Supply I ² C Pin Definitions	
Pin#	Definition
1	Clock
2	Data
3	PWR Fail
4	Ground
5	3.3V

Wake-On-LAN

The Wake-On-LAN header is located at JSTBY1 on the serverboard. See the table on the right for pin definitions. (You must also have a LAN card with a Wake-On-LAN connector and cable to use this feature.)

Wake-On-LAN Pin Definitions (JWOL)	
Pin#	Definition
1	+5V Standby
2	Ground
3	Wake-up

T-SGPIO 1/2 Headers

Two T-SGPIO (Serial-Link General Purpose Input/Output) headers are located next to the I-SATA ports on the serverboard. These headers are used to communicate with the enclosure management chip in the system. T-SGPIO 1 is for SATA 0~5 ports and T-SGPIO 2 is for SATA 4/5 ports . An additional SCU-SGPIO header is provided for the SCU SATA ports. See the table on the right for pin definitions.

Serial_Link-SGPIO Pin Definitions			
Pin#	Definition	Pin	Definition
1	NC	2	NC
3	Ground	4	DATA Out
5	Load	6	Ground
7	Clock	8	NC

Ethernet Ports

Two Gigabit Ethernet ports (LAN1/2) are located on the I/O backplane on the serverboard to provide internet connections. In addition, an IPMI_Dedicated LAN, located above USB 0/1 ports on the backplane, provides KVM support for IPMI 2.0. All these ports accept RJ45 type cables.

Note: Please refer to the LED Indicator Section for LAN LED information.

LAN Ports Pin Definition			
Pin#	Definition		
1	P2V5SB	10	SGND
2	TD0+	11	Act LED
3	TD0-	12	P3V3SB
4	TD1+	13	Link 100 LED (Yellow, +3V3SB)
5	TD1-	14	Link 1000 LED (Yellow, +3V3SB)
6	TD2+	15	Ground
7	TD2-	16	Ground
8	TD3+	17	Ground
9	TD3-	18	Ground

(NC: No Connection)

Unit ID Switch (UID SW)

The rear UID switch, the rear UID LED and front UID LED on JF1 are designed to work together. When the user pushes the rear UID switch, the blue backpanel UID LED and front UID LED will turn on. Push the rear UID switch again to turn off UID LED and the front UID LED. This provides easy identification of a system unit that may be in need of service.

Note: UID can also be triggered via IPMI on the serverboard. For more information on IPMI, please refer to the IPMI User's Guide posted on our website.

UID Switch	
Pin#	Definition
1	Ground
2	Ground
3	Button In
4	Ground

UID LED (LE2) Status		
Color/State	OS	Status
Blue: On	Windows OS	Unit Identified
Blue: Blinking	Linux OS	Unit Identified

Overheat/Fan Fail LED (JOH1)

The JOH1 header is used to connect an LED to provide warnings of chassis over-heat. This LED will also blink to indicate a fan failure. Refer to the table on right for pin definitions.

Overheat LED Pin Definitions	
Pin#	Definition
1	P3V3
2	OH Active

OH/Fan Fail LED Pin Definitions	
State	Message
Solid	Overheat
Blinking	Fan Fail

Internal Buzzer (SP1)

The Internal Buzzer (SP1) can be used to provide audible indications for various beep codes. See the table on the right for pin definitions.

Internal Buzzer Pin Definition		
Pin#	Definitions	
Pin 1	Pos. (+)	Beep In
Pin 2	Neg. (-)	Alarm Speaker

5-9 Jumper Settings

Explanation of Jumpers

To modify the operation of the serverboard, jumpers can be used to choose between optional settings. Jumpers create shorts between two pins to change the function of the connector. Pin 1 is identified with a square solder pad on the printed circuit board. See the diagram at right for an example of jumping pins 1 and 2. Refer to the serverboard layout page for jumper locations.

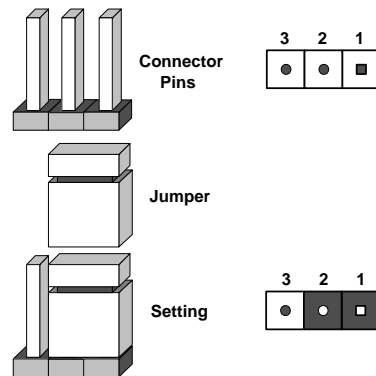

Note: On two-pin jumpers, "Closed" means the jumper is on and "Open" means the jumper is off the pins.

CMOS Clear

JBT1 is used to clear CMOS and will also clear any passwords. Instead of pins, this jumper consists of contact pads to prevent accidentally clearing the contents of CMOS.

To Clear CMOS

1. First power down the system and unplug the power cord(s).
2. With the power disconnected, short the CMOS pads with a metal object such as a small screwdriver.
3. Remove the screwdriver (or shorting device).
4. Reconnect the power cord(s) and power on the system.

Note: Do not use the PW ON connector to clear CMOS.

VGA Enable/Disable

JPG1 allows you to enable or disable the VGA port. The default position is on pins 1 and 2 to enable VGA. See the table on the right for jumper settings.

VGA Enable/Disable Jumper Settings	
Setting	Definition
Pins 1-2	Enabled
Pins 2-3	Disabled

I²C Bus to CPU1/CPU2 VRMs

Use Jumpers JVRM_I²C1/JVRM_I²C2 to connect the System Management Bus (I²C) to the CPU1/CPU2 VRMs. The default setting for the is on pins 1-2 to enable the connection. See the tables on the right for jumper settings.

I ² C to VRMs (for X9DBL-3F/iF) Jumper Settings	
Jumper Setting	Definition
Pins 1-2	Enabled (Default)

I ² C to VRMs (for X9DBL-3/i) Jumper Settings	
Jumper Setting	Definition
Pins 2-3	Enabled (Default)

LAN Port Enable/Disable

Use JPL1/JPL2 to enable or disable LAN Ports 1 and 2 on the serverboard. See the table on the right for jumper settings. The default setting is enabled.

LAN Port En/Disable Jumper Settings	
Setting	Definition
1-2	Enabled
2-3	Disabled

BMC Enable/Disable

JPB1 is used to enable or disable the BMC (Baseboard Management Control) chip to provide IPMI 2.0/KVM support. The default position is on pins 1 and 2 to Enable BMC. See the table on the right for jumper settings.

BMC IPMI Enable/Disable Jumper Settings	
Setting	Definition
Pins 1-2	Enabled
Pins 2-3	Disabled

Watch Dog Enable

Watch Dog is a system monitor that can reboot the system when a software application hangs. Close pins 1-2 of JWD1 to reset the system if an application hangs. Close pins 2-3 to generate a non-maskable interrupt signal for the application that hangs. See the table on the right for jumper settings. Watch Dog must also be enabled in the BIOS.

Watch Dog Jumper Settings	
Setting	Definition
Pins 1-2	Reset (default)
Pins 2-3	NMI
Open	Disabled

5-10 Onboard Indicators

LAN1/LAN2 LEDs

The Ethernet ports (located beside the VGA port) have two LEDs. On each Gigabit LAN port, one LED indicates activity when blinking while the other LED may be green, amber or off to indicate the speed of the connection. See the table on the right for the functions associated with the connection speed LED.

LAN LED Connection Speed Indication	
LED State	Definition
Off	No connection or 10 Mb/s
Green	100 Mbps
Amber	1 Gbps

IPMI Dedicated LAN LEDs

In addition to the Gigabit Ethernet ports, an IPMI Dedicated LAN is also located above the Backplane USB ports 0/1 on the X9DBL-iF. The amber LED on the right indicates activity, while the green LED on the left indicates the speed of the connection. See the tables at right for more information.

IPMI LAN Link LED & Activity LEDs		
	Color/State	Definition
Link (Left)	Green: Solid	100 Mbps
Activity (Right)	Amber: Blinking	Active

Rear Unit ID LED (UID LED)

The rear Unit ID LED is located at the rear of the serverboard. This LED is used in conjunction with the rear UID switch to provide easy identification of a system that might be in need of service.

UID LED Status		
Color/State	OS	Status
Blue: On	Windows OS	Unit Identified
Blue: Blinking	Linux OS	Unit Identified

BMC Heartbeat LED

A BMC Heartbeat LED is located at LED1 on the serverboard. When LED1 is blinking, BMC functions normally. See the table at right for more information.

BMC Heartbeat LED Status	
Color/State	Definition
Green: Blinking	BMC: Normal

Onboard Power LED

An Onboard Power LED is located at LED2 on the serverboard. When this LED is on, the system is on. Be sure to turn off the system and unplug the power cord before removing or installing components. See the tables at right for more information.

Onboard PWR LED Indicator LED Settings	
LED Color	Status
Off	System Off (PWR cable not connected)
Green	System On
Green: Flashing Quickly	ACPI S1 State
Green: Flashing Slowly	ACPI S3 (STR) State

5-11 SATA Ports

SATA Ports

Six Serial ATA (SATA) ports (I-SATA 0~5) are included on the serverboard. See the table on the right for pin definitions for the onboard SATA ports.

SATA Port Pin Definitions	
Pin #	Definition
1	Ground
2	TXP
3	TXN
4	Ground
5	RXN
6	RXP
7	Ground

5-12 Installing Drivers

After all the hardware and operating system have been installed, you need to install certain drivers. The necessary drivers are all included on the Supermicro CD that came packaged with your serverboard. After inserting this CD into your CD-ROM drive, the display shown in Figure 5-4 should appear. (If this display does not appear, click on the My Computer icon and then on the icon representing your CD-ROM drive. Finally, double click on the S "Setup" icon.)

Figure 5-6. Driver Installation Display Screen

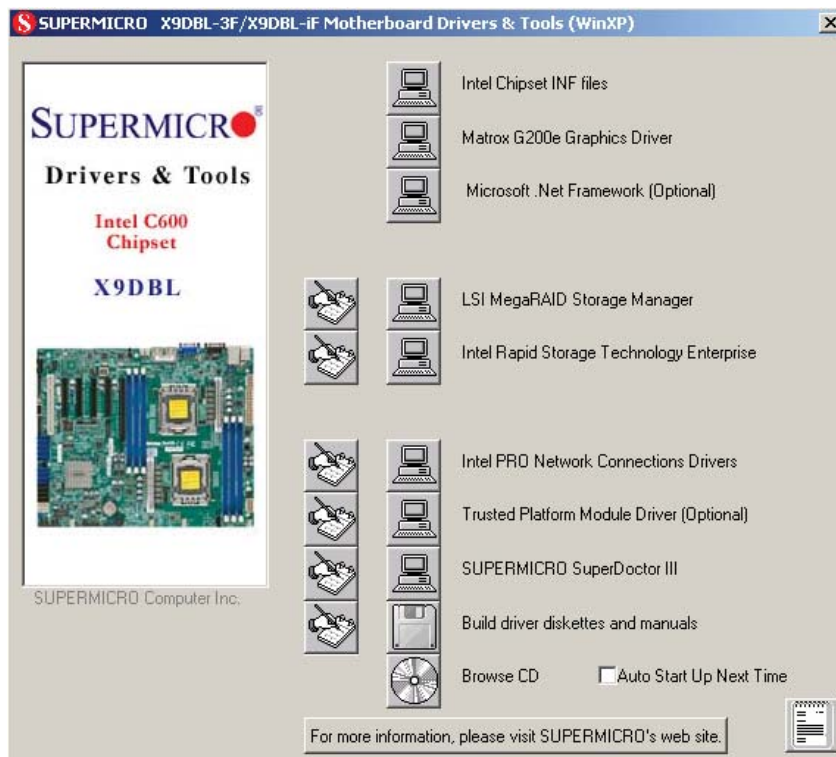

Click the icons showing a hand writing on paper to view the readme files for each item. Click the tabs to the right of these *in order from top to bottom* to install each item one at a time. **After installing each item, you must reboot the system before moving on to the next item on the list.** You should install everything here except for the SUPER Doctor utility, which is optional. The bottom icon with a CD on it allows you to view the entire contents of the CD.

SuperDoctor III

The SuperDoctor® III program is a Web base management tool that supports remote management capability. It includes Remote and Local Management tools. The local management is called SD III Client. The SuperDoctor III program included on the CD-ROM that came with your serverboard allows you to monitor the environment and operations of your system. SuperDoctor III displays crucial system information such as CPU temperature, system voltages and fan status. See the Figure below for a display of the SuperDoctor III interface.

Note: The default User Name and Password for SuperDoctor III is ADMIN / ADMIN.

Note: When SuperDoctor is first installed, it adopts the temperature threshold settings that have been set in BIOS. Any subsequent changes to these thresholds must be made within SuperDoctor, as the SuperDoctor settings override the BIOS settings. To set the BIOS temperature threshold settings again, you would first need to uninstall SuperDoctor.

SuperDoctor III Interface Display Screen (Health Information)

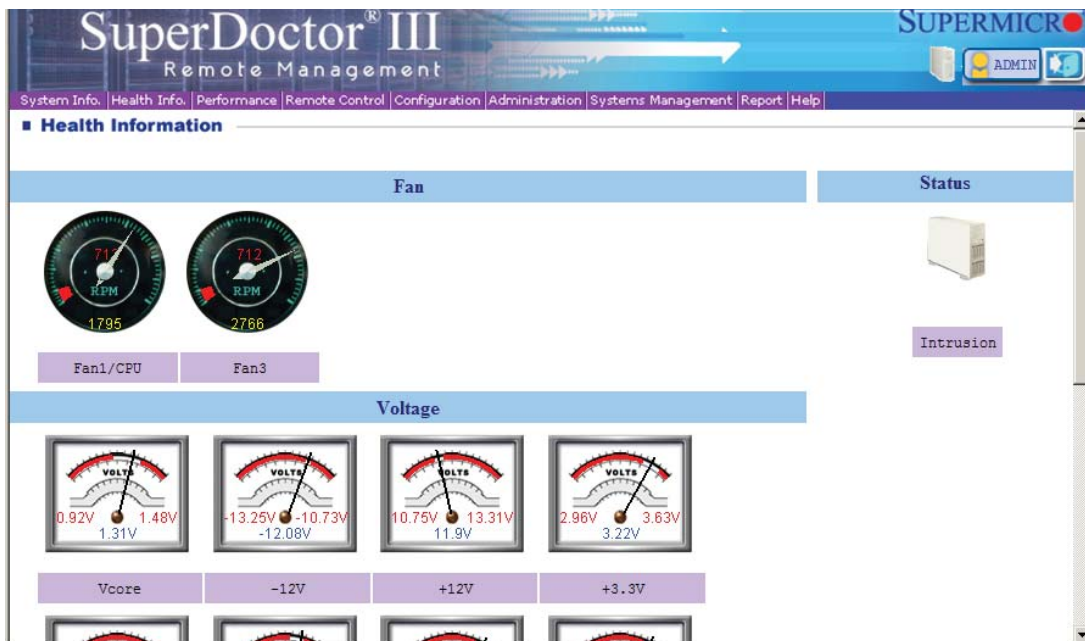

SuperDoctor III Interface Display Screen (Remote Control)

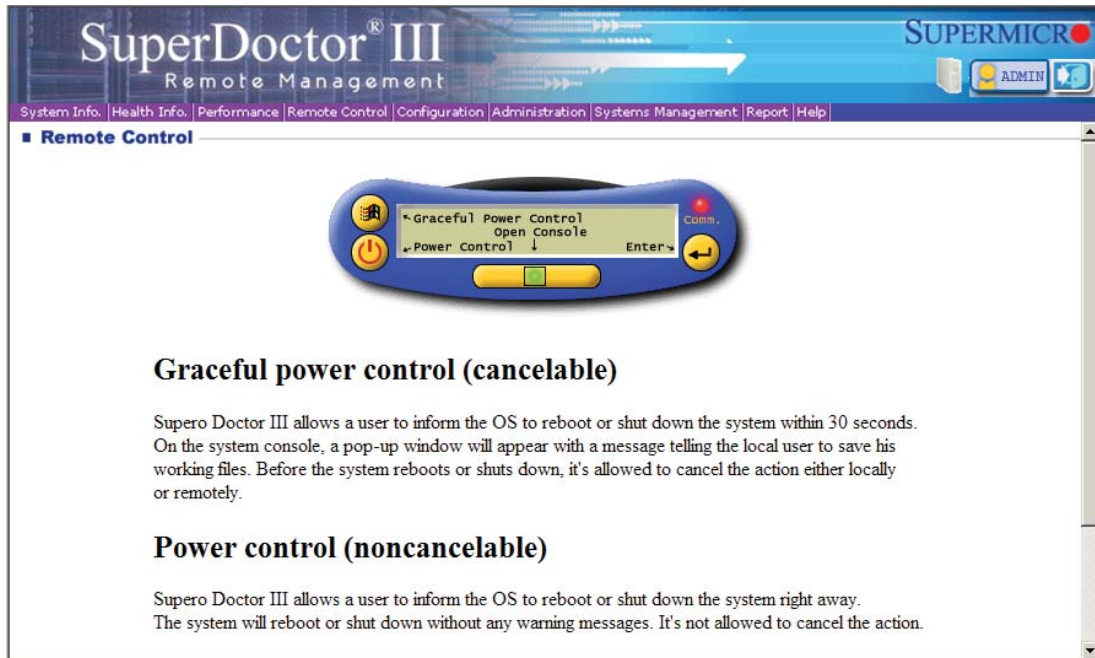

Note: The SuperDoctor III program and User's Manual can be downloaded from the Supermicro web site at <http://www.supermicro.com/products/accessories/software/SuperDoctorIII.cfm>.

For Linux, we recommend using SuperDoctor II.

Chapter 6

Advanced Chassis Setup

This chapter covers the steps required to install components and perform maintenance on the SC813MTQ chassis. For component installation, follow the steps in the order given to eliminate the most common problems encountered. If some steps are unnecessary, skip ahead to the step that follows.

Tools Required: The only tool you will need to install components and perform maintenance is a Phillips screwdriver.

6-1 Static-Sensitive Devices

Electrostatic Discharge (ESD) can damage electronic components. To prevent damage to any printed circuit boards (PCBs), it is important to handle them very carefully. The following measures are generally sufficient to protect your equipment from ESD discharge.

Precautions

- Use a grounded wrist strap designed to prevent static discharge.
- Touch a grounded metal object before removing any board from its antistatic bag.
- Handle a board by its edges only; do not touch its components, peripheral chips, memory modules or gold contacts.
- When handling chips or modules, avoid touching their pins.
- Put the serverboard, add-on cards and peripherals back into their antistatic bags when not in use.
- For grounding purposes, make sure your computer chassis provides excellent conductivity between the power supply, the case, the mounting fasteners and the serverboard.

Figure 6-1. Chassis Front View

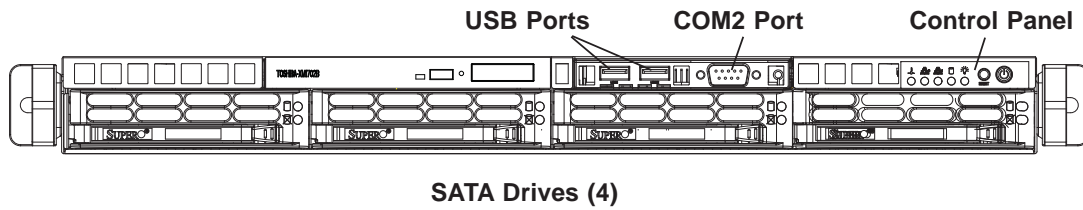

Note: above image shows server with optional front USB and COM ports.

Figure 6-2. Chassis Rear View

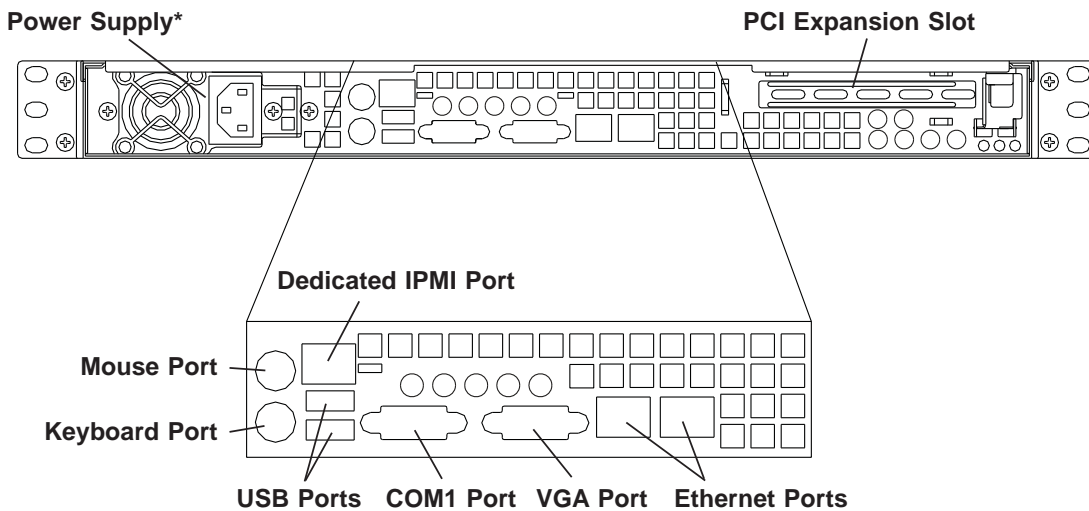

*The 6017B-MTRF includes two power supplies for redundancy.

6-2 Control Panel

The control panel (located on the front of the chassis) must be connected to the JF1 connector on the serverboard to provide you with system control buttons and status indicators. These wires have been bundled together in a ribbon cable to simplify the connection.

The LEDs inform you of system status. See Chapter 3 for details on the LEDs and the control panel buttons. Details on JF1 can be found in Chapter 5.

6-3 Accessing the Inside of the System

You will need to access the inside of the system to perform maintenance such as replacing fans and add-on cards.

1. Grasp the two handles on either side and pull the unit straight out until it locks (you will hear a "click").
2. Depress the two buttons on the top of the chassis to release the top cover. Push the cover away from you until it stops.
3. Lift the top cover from the chassis to gain full access to the inside of the server. See Figure 6-3.

Figure 6-3. Accessing the Inside of the System

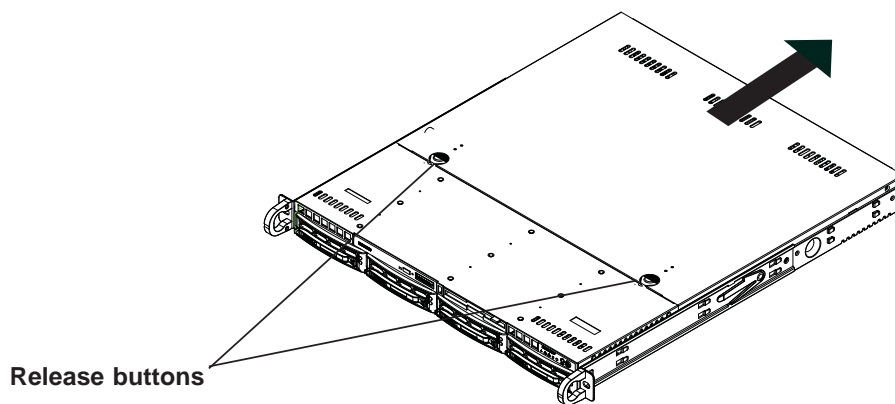

6-4 System Fans

Four 4-cm high-performance fans provide the cooling for the SuperServer 6017B-MTF/6017B-MTLF/6017B-MTRF. The chassis includes air seals under the fans and at the chassis cross section, which separates the drive bay area from the serverboard area of the chassis to promote better airflow. It is highly important that the air seal is properly installed and making a good seal in order for the cooling air to circulate properly through the chassis.

The fans can adjust their speed according to the heat level sensed in the system, which results in more efficient and quieter fan operation. Fan speed is controlled by a setting in BIOS.

System Fan Failure

If a fan fails, you will need to have it replaced with the same type. Contact your vendor or Supermicro for information on replacement fans.

6-5 Drive Bay Installation/Removal

Removing the Front Bezel

If your system has a front bezel (optional) attached to the chassis, you must first remove it to gain access to the drive bays. To remove the bezel, first unlock the front of the chassis then press the release knob (see Figure 6-4). Carefully remove the bezel with both hands. A filter located within the bezel can be removed for replacement/cleaning. It is recommended that you keep a maintenance log of filter cleaning/replacement, since its condition will affect the airflow throughout the whole system.

Figure 6-4. Removing the Front Bezel

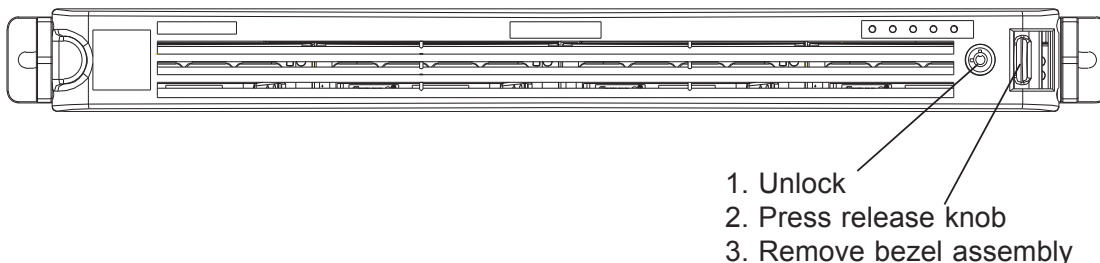

Accessing the Drive Bays

SATA Drives: Because of their hotswap capability, you do not need to access the inside of the chassis or power down the system to install or replace SATA drives. Proceed to the next step for instructions. **Note:** The operating system you use must have RAID support to enable the hot-swap capability of the drives.

DVD-ROM Drive: For installing/removing a DVD-ROM drive, you will need to gain access to the inside of the server by removing the top cover of the chassis. Proceed to the "DVD-ROM Drive Installation" section in this chapter for instructions. Note that only a "slim" DVD-ROM drive will fit into the 6017B-MTF/6017B-MTLF/6017B-MTRF.

Note: A DVD drive does not come standard with the system.



Use caution when working around the SATA backplane. Do not touch the backplane with any metal objects and make sure no ribbon cables touch the backplane. Also, regardless of how many drives are installed, all four drive carriers must remain in the chassis to maintain proper airflow.



Enterprise level hard disk drives are recommended for use in Supermicro chassis and servers. For information on recommended HDDs, visit the Supermicro Web site at <http://www.supermicro.com/products/nfo/files/storage/SAS-1-CompList-110909.pdf>

Hard Drive Installation

Mounting a Drive in a Drive Carrier

The hard drives are mounted in drive carriers to simplify their installation and removal from the chassis. These carriers also help promote proper airflow for the system. For this reason, even empty carriers without drives installed must remain in the chassis.

1. Install a new drive into the carrier with the printed circuit board side facing down so that the mounting holes align with those in the carrier.
2. Secure the drive to the carrier with six screws, as shown in Figure 6-5.

Installing/Removing Hard Drives

1. To remove a carrier, push the release button located beside the drive LEDs.
2. Swing the colored handle fully out and use it to pull the unit straight out (see Figure 6-6).

Note: There is no onboard RAID support for hard drives.

Figure 6-5. Mounting a Drive in a Carrier

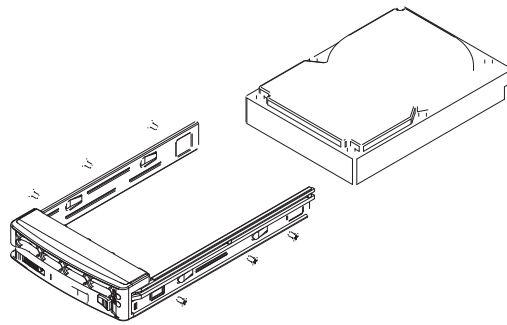

SATA Backplane

The SATA drives plug into a backplane that provides power, drive ID and bus termination. A RAID controller can be used with the backplane to provide data security for the drives. The backplane is already preconfigured, so there are no jumpers or switches present on it.

Figure 6-6. Removing a Drive from the Server

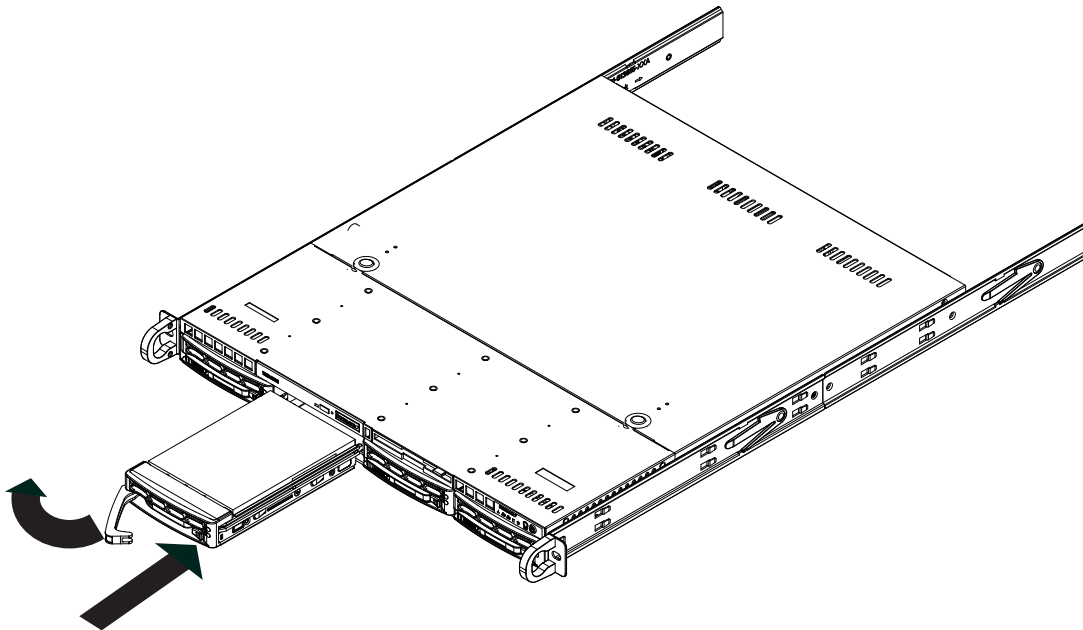

DVD-ROM Drive Installation

The top cover of the chassis must be opened to gain full access to the DVD-ROM drive bay. The 6017B-MTF/6017B-MTLF/6017B-MTRF accommodates only slim DVD-ROM drives. Side mounting brackets are needed to mount a slim DVD-ROM drive into the 6017B-MTF/6017B-MTLF/6017B-MTRF server. You must power down the system before installing or removing a DVD-ROM drive. Note that the DVD drive is optional; it does not come already installed in the system but may be installed by the user.

Removing the Chassis Cover

1. Grasp the two handles on either side and pull the unit straight out until it locks (you will hear a "click").
2. Depress the two buttons on the top of the chassis to release the top cover and at the same time, push the cover away from you until it stops. You can then lift the top cover from the chassis to gain full access to the inside of the server.

Removing/Installing a Drive

1. With the chassis cover removed, unplug the power and data cables from the drive.
2. Locate the locking tab at the rear of the drive. It will be on the left side of the drive when viewed from the front of the chassis.
3. Pull the tab away from the drive and push the drive unit out the front of the chassis.
4. Add a new drive by following this procedure in reverse order. You may hear a faint *click* of the locking tab when the drive is fully inserted.
5. Remember to reconnect the data and power cables to the drive before replacing the chassis cover and restoring power to the system.

6-6 Power Supply

6017B-MTF/6017B-MTLF Power

The 6017B-MTF has a single 440 watt power supply and the 6017B-MTLF has a single 350 watt power supply. This power supply has the capability of operating at 100 - 240 input volts. Depress the main power button on the front of the chassis and then unplug the AC power cord to completely remove power from the system before removing the power supply.

Power Supply Failure

If the power supply unit fails, the system will shut down and you will need to replace the power supply unit. Replacement units can be ordered directly from Supermicro (see contact information in Chapter 1).

Replacing the Power Supply

To replace a power supply, you must first remove the top chassis cover. Follow the procedure in Section 6-3.

1. First power down the system and unplug the AC power cord from the power supply.
2. To remove the failed power unit, remove the two screws on the back of the power supply, which secure it to the chassis. You can then lift the unit straight out of the chassis.
3. Replace the failed unit with another unit of the same wattage. You must replace it with the exact same power supply (same model number).
4. Carefully insert the new unit into position into the chassis and secure it with the two screws at the rear of the unit.
5. Before reconnecting the power cord, make sure the power switch on the power module is in the off position. Then reconnect the power cord, replace the top chassis cover and push the unit back into the rack.
6. Finish by turning the power switch on the power module on, then power up the server with the power button on the front control panel.

6017B-MTRF Power

The 6017B-MTRF has a 400 watt redundant power supply consisting of two power modules. Each power supply module has an auto-switching capability, which enables it to automatically sense and operate at a 100V - 240V input voltage.

If either of the two power supply modules fail, the other module will take the full load and allow the system to continue operation without interruption. The PWR Fail LED will illuminate and remain on until the failed unit has been replaced. Replacement units can be ordered directly from Supermicro.

The power supply units have a hot-swap capability, meaning you can replace the failed unit without powering down the system.

Removing the Power Supply

1. First unplug the AC power cord from the failed power supply module.
2. To remove the failed power unit, push the release tab on the rear of the power module then pull it straight out of the chassis.
3. Replace the failed unit with another unit of the same wattage. You must replace it with the exact same power supply (same model number).
4. Carefully insert the new unit into position into the empty bay until firmly seated.
5. Reconnect the power cord.

Notes

Chapter 7

BIOS

7-1 Introduction

This chapter describes the AMI BIOS Setup utility for the X9DBL-i/3/iF/3F. It also provides the instructions on how to navigate the AMI BIOS Setup utility screens. The AMI ROM BIOS is stored in a Flash EEPROM and can be easily updated.

Starting BIOS Setup Utility

To enter the AMI BIOS Setup utility screens, press the key while the system is booting up.

 **Note:** In most cases, the key is used to invoke the AMI BIOS setup screen. There are a few cases when other keys are used, such as <F3>, <F4>, etc.

Each main BIOS menu option is described in this manual. The Main BIOS setup menu screen has two main frames. The left frame displays all the options that can be configured. Grayed-out options cannot be configured. Options in blue can be configured by the user. The right frame displays the key legend. Above the key legend is an area reserved for informational text. When an option is selected in the left frame, it is highlighted in white. Often, informational text about the option will display on the right.

 **Note:** The AMI BIOS has default informational messages built in. The manufacturer retains the option to include, omit, or change any of these informational messages.

The AMI BIOS Setup utility uses a key-based navigation system called "hot keys." Most of the AMI BIOS setup utility "hot keys" can be used at any time during setup navigation. These keys include <F3>, <F4>, <Enter>, <ESC>, arrow keys, etc.

 **Note 1:** In this section, options printed in **Bold** are default settings.

Note 2: <F3> is used to load optimal default settings. <F4> is used to save the settings and exit the setup utility.

How To Change the Configuration Data

The configuration data that determines the system parameters may be changed by entering the AMI BIOS Setup utility. This Setup utility can be accessed by pressing <Delete> at the appropriate time during system boot.

 **Note:** For AMI UEFI BIOS Recovery, please refer to the UEFI BIOS Recovery User Guide posted @<http://www.supermicro.com/support/manuals/>.

Starting the Setup Utility

Normally, the only visible Power-On Self-Test (POST) routine is the memory test. As the memory is being tested, press the <Delete> key to enter the main menu of the AMI BIOS Setup utility. From the main menu, you can access the other setup screens. An AMI BIOS identification string is displayed at the left bottom corner of the screen below the copyright message.

 **Warning!** Do not upgrade the BIOS unless your system has a BIOS-related issue. Flashing the wrong BIOS can cause irreparable damage to the system. In no event shall the manufacturer be liable for direct, indirect, special, incidental, or consequential damage arising from a BIOS update. If you have to update the BIOS, do not shut down or reset the system while the BIOS is being updated to avoid possible boot failure.

7-2 Main Setup

When you first enter the AMI BIOS Setup utility, you will enter the Main setup screen. You can always return to the Main setup screen by selecting the Main tab on the top of the screen. The Main BIOS Setup screen is shown below.



The AMI BIOS main menu displays the following information:

System Date/System Time

Use this option to change the system time and date. Highlight *System Time* or *System Date* using the arrow keys. Enter new values through the keyboard and press <Enter>. Press the <Tab> key to move between fields. The date must be entered in Day MM/DD/YY format. The time is entered in HH:MM:SS format. (**Note:** The time is in the 24-hour format. For example, 5:30 P.M. appears as 17:30:00.).

Supermicro X9DBL-3F/X9DBL-iF**Version**

This item displays the SMC version of the BIOS ROM used in this system.

Build Date

This item displays the date that the BIOS ROM was built.

Memory Information**Total Memory**

This displays the amount of memory that is available in the system.

7-3 Advanced Setup Configurations

Use the arrow keys to select Advanced Setup and press <Enter> to access the following submenu items.



► Boot Features

Quiet Boot

This feature allows the user to select bootup screen display between POST messages and the OEM logo. Select Disabled to display the POST messages. Select Enabled to display the OEM logo instead of the normal POST messages. The options are **Enabled** and Disabled.

AddOn ROM Display Mode

Use this item to set the display mode for the Option ROM. Select Keep Current to use the current AddOn ROM Display setting. Select Force BIOS to use the Option ROM display mode set by the system BIOS. The options are **Force BIOS** and Keep Current.

Bootup Num-Lock

Use this feature to set the Power-on state for the Numlock key. The options are Off and **On**.

Wait For 'F1' If Error

Select Enabled to force the system to wait until the 'F1' key is pressed if an error occurs. The options are Disabled and **Enabled**.

Interrupt 19 Capture

Interrupt 19 is the software interrupt that handles the boot disk function. When this item is set to Enabled, the ROM BIOS of the host adaptors will "capture" Interrupt 19 at bootup and allow the drives that are attached to these host adaptors to function as bootable disks. If this item is set to Disabled, the ROM BIOS of the host adaptors will not capture Interrupt 19, and the drives attached to these adaptors will not function as bootable devices. The options are **Enabled** and Disabled.

Re-try Boot

If this item is enabled, the BIOS will automatically attempt to boot from a specified boot device again after its initial failure to boot. The default setting is **Disabled**.

Power Configuration

Watch Dog Function

If enabled, the Watch Dog timer will allow the system to automatically reboot when a non-recoverable error occurs that lasts for more than five minutes. The options are Enabled and **Disabled**.

Power Button Function

If this feature is set to Instant Off, the system will power off immediately as soon as the user presses the power button. If this feature is set to 4 Seconds Override, the system will power off when the user presses the power button for 4 seconds or longer. The options are **Instant Off** and 4 Seconds Override.

Restore on AC Power Loss

Use this feature to set the power state after a power outage. Select Stay Off for the system power to remain off after a power loss. Select Power On for the system power to be turned on after a power loss. Select Last State to allow the system to resume its last state before a power loss. The options are Power On, Stay Off, and **Last State**.

CPU Configuration

This submenu displays the information of the CPU as detected by the BIOS. It also allows the user to configure CPU settings.

► **Socket 1 CPU Information/Socket 2 CPU Information**

This submenu displays the following information regarding the CPUs installed in Socket 1/ Socket 2.

- Type of CPU
- CPU Signature
- Microcode Patch
- CPU Stepping
- Maximum CPU Speed
- Minimum CPU Speed
- Processor Cores
- Intel HT (Hyper-Threading) Technology
- Intel VT-x Technology
- Intel SMX Technology
- L1 Data Cache
- L1 Code Cache
- L2 Cache
- L3 Cache

CPU Speed

This item displays the speed of the CPU installed in Socket 1/Socket 2.

64-bit

This item indicates if the CPU installed in Socket 1 or Socket 2 supports 64-bit technology.

Clock Spread Spectrum

Select Enable to enable Clock Spectrum support, which will allow the BIOS to monitor and attempt to reduce the level of Electromagnetic Interference caused by the components whenever needed. The options are **Disabled** and Enabled.

RTID (Record Types IDs)

This feature displays the total number of Record Type IDs for local and remote pools. The options are **Optimal** and Alternate.

Hyper-threading

Select Enabled to support Intel Hyper-threading Technology to enhance CPU performance. The options are **Enabled** and Disabled.

Active Processor Cores

Set to Enabled to use a processor's second core and above. (Please refer to Intel's website for more information.) The options are **All**, 1, and 2.

Limit CPUID Maximum

This feature allows the user to set the maximum CPU ID value. Enable this function to boot the legacy operating systems that cannot support processors with extended CPUID functions. The options are Enabled and **Disabled** (for the Windows OS).

Execute-Disable Bit (Available if supported by the OS & the CPU)

Select Enabled to enable the Execute Disable Bit which will allow the processor to designate areas in the system memory where an application code can execute and where it cannot, thus preventing a worm or a virus from flooding illegal codes to overwhelm the processor or damage the system during an attack. The default is **Enabled**. (Refer to Intel and Microsoft Web sites for more information.)

Intel® AES-NI

Select Enable to use the Intel Advanced Encryption Standard (AES) New Instructions (NI) to ensure data security. The options are **Enabled** and Disabled.

MLC Streamer Prefetcher (Available when supported by the CPU)

If set to Enabled, the MLC (mid-level cache) streamer prefetcher will prefetch streams of data and instructions from the main memory to the L2 cache to improve CPU performance. The options are Disabled and **Enabled**.

MLC Spatial Prefetcher (Available when supported by the CPU)

If this feature is set to Disabled, The CPU prefetches the cache line for 64 bytes. If this feature is set to Enabled the CPU fetches both cache lines for 128 bytes as comprised. The options are Disabled and **Enabled**.

DCU Streamer Prefetcher (Available when supported by the CPU)

Select Enabled to support Data Cache Unit (DCU) prefetch of L1 data to speed up data accessing and processing in the DCU to enhance CPU performance. The options are Disabled and **Enabled**.

DCU IP Prefetcher

Select Enabled for DCU (Data Cache Unit) IP Prefetcher support, which will prefetch IP addresses to improve network connectivity and system performance. The options are **Enabled** and Disabled.

Intel® Virtualization Technology (Available when supported by the CPU)

Select Enabled to support Intel Virtualization Technology, which will allow one platform to run multiple operating systems and applications in independent partitions, creating multiple "virtual" systems in one physical computer. The options are **Enabled** and Disabled.

 **Note:** If there is any change to this setting, you will need to power off and restart the system for the change to take effect. Please refer to Intel's website for detailed information.)

► CPU Power Management Configuration

This submenu allows the user to configure the following CPU Power Management settings.

Power Technology

Select Energy Efficiency to support power-saving mode. Select Custom to customize system power settings. Select Disabled to disable power-saving settings. The options are Disabled, **Energy Efficient**, and Custom. If the option is set to Custom, the following items will display:

EIST (Available when Power Technology is set to Custom)

EIST (Enhanced Intel SpeedStep Technology) allows the system to automatically adjust processor voltage and core frequency to reduce power consumption and heat dissipation. The options are Disabled (GV3 Disabled), and **Enabled (GV3 Enabled)**. (**Note:** GV3 is Intel Speedstep support used on older platforms. Please refer to Intel's website for detailed information.)

C1E Support (Available when Power Technology is set to Custom)

Select Enabled to enable Enhanced C1 Power State to boost system performance. The options are **Enabled** and Disabled.

CPU C3 Report (Available when Power Technology is set to Custom)

Select Enabled to allow the BIOS to report the CPU C3 State (ACPI C2) to the operating system. During the CPU C3 State, the CPU clock generator is turned off. The options are Enabled and **Disabled**.

CPU C6 Report (Available when Power Technology is set to Custom)

Select Enabled to allow the BIOS to report the CPU C6 State (ACPI C3) to the operating system. During the CPU C6 State, the power to all cache is turned off. The options are **Enabled** and Disabled.

CPU C7 Report (Available when Power Technology is set to Custom)

Select Enabled to allow the BIOS to report the CPU C7 State (ACPI C3) to the operating system. CPU C7 State is a processor-specific low C-State. The options are **Enabled** and Disabled.

Package C-State limit (Available when Power Technology is set to Custom)

This feature allows the user to set the limit on the C-State package register. The options are C0, C2, **C6**, and No Limit.

Energy Performance Bias

Use this feature to select an appropriate fan setting to achieve maximum system performance (with maximum cooling) or maximum energy efficiency with maximum power saving). The fan speeds are controlled by the firmware management via IPMI 2.0. The options are Performance, **Balanced Performance**, Balanced Energy, and Energy Efficient.

Factory Long Duration Power Limit

This item displays the power limit (in watts) set by the manufacturer during which long duration power is maintained.

Long Duration Power Limit

This item displays the power limit (in watts) set by the user during which long duration power is maintained. The default setting is **0**.

Factory Long Duration Maintained

This item displays the period of time (in seconds) set by the manufacturer during which long duration power is maintained.

Long Duration Maintained

This item displays the period of time (in seconds) during which long duration power is maintained. The default setting is **0**.

Recommended Short Duration Power Limit

This item displays the short duration power settings (in watts) recommended by the manufacturer.

Short Duration Power Limit

During Turbo Mode, the system may exceed the processors default power setting and exceed the Short Duration Power limit. By increasing this value, the processor can provide better performance for short duration. This figure shows the period of time in during which short duration power (in watts) is maintained. The default setting is **0**.

► Chipset Configuration

► North Bridge

This feature allows the user to configure the settings for the Intel North Bridge.

► Integrated IO Configuration

Intel® VT-d

Select Enabled to enable Intel Virtualization Technology support for Direct I/O VT-d by reporting the I/O device assignments to the VMM (Virtual Machine Monitor) through the DMAR ACPI Tables. This feature offers fully-protected I/O resource sharing across Intel platforms, providing greater reliability, security and availability in networking and data-sharing. The options are **Enabled** and Disabled.

Intel® I/OAT

Select Enabled to enable Intel I/OAT (I/O Acceleration Technology), which significantly reduces CPU overhead by leveraging CPU architectural improvements and freeing the system resource for other tasks. The options are Disabled and **Enabled**.

DCA Support

When set to Enabled, this feature uses Intel's DCA (Direct Cache Access) Technology to improve data transfer efficiency. The options are **Enabled** and Disabled.

IIO 1 PCIe Port Bifurcation Control

This submenu configures the following IO PCIe Port Bifurcation Control settings for IIO 1 PCIe ports to determine how the available PCI-Express lanes to be distributed between the PCI-Exp. Root Ports.

Port 1B Link Speed

Select GEN1 to enable PCI-Exp Generation 1 support for Port 1B. Select GEN2 to enable PCI-Exp Generation 2 support for Port 1B. Select GEN3 to enable PCI-Exp Generation 3 support for Port 1B. The options are GEN1, GEN2, and **GEN3**.

Port 3A Link Speed

Select GEN1 to enable PCI-Exp Generation 1 support for Port 3A. Select GEN2 to enable PCI-Exp Generation 2 support for Port 3A. Select GEN3 to enable PCI-Exp Generation 3 support for Port 3A. The options are GEN1, GEN2, and **GEN3**.

IIO 1 PCIe Port Data Direct I/O Control

This feature configures the following IO PCIe port data direct I/O control settings for IIO 1 PCIe ports. Intel's Data Direct I/O control allows direct data transfer between the host processor cache and the Ethernet controllers/adaptors. This direct communication greatly reduces trips to the main memory, which increases performance while also lowering power consumption.

Port 0A

This feature allows the user to enable Data Direct I/O control for the port specified. The options are Enabled and **Disabled**.

Port 1A, Port 1B, Port 2A, Port 2B, Port 3A

This feature allows the user to enable Data Direct I/O control for the ports specified. The options are **Enabled** and Disabled.

Port 3C Link Speed

Select GEN1 to enable PCI-Exp Generation 1 support for Port 3C. Select GEN2 to enable PCI-Exp Generation 2 support for Port 3C. Select GEN3 to enable PCI-Exp Generation 3 support for Port 3C. The options are GEN1, GEN2, and **GEN3**.

IIO 2 PCIe Port Bifurcation Control

This submenu configures the following IO PCIe Port Bifurcation Control settings for IIO 2 PCIe ports to determine how the available PCI-Express lanes to be distributed between the PCI-Exp. Root Ports.

Port 1A Link Speed

Select GEN1 to enable PCI-Exp Generation 1 support for Port 1A. Select GEN2 to enable PCI-Exp Generation 2 support for Port 1A. Select GEN3 to enable PCI-Exp Generation 3 support for Port 1A. The options are GEN1, GEN2, and **GEN3**.

Port 3A Link Speed

Select GEN1 to enable PCI-Exp Generation 1 support for Port 3A. Select GEN2 to enable PCI-Exp Generation 2 support for Port 3A. Select GEN3 to enable PCI-Exp Generation 3 support for Port 3A. The options are GEN1, GEN2, and **GEN3**.

Port 3C Link Speed

Select GEN1 to enable PCI-Exp Generation 1 support for Port 3C. Select GEN2 to enable PCI-Exp Generation 2 support for Port 3C. Select GEN3 to enable PCI-Exp Generation 3 support for Port 3C. The options are GEN1, GEN2, and **GEN3**.

IIO 2 PCIe Port Data Direct I/O Control

This feature configures the following IO PCIe port data direct I/O control settings for IIO 2 PCIe ports. Intel's Data Direct I/O control allows direct data transfer between the host processor cache and the Ethernet controllers/adaptors. This direct communication greatly reduces trips to the main memory, which increases performance while also lowering power consumption.

Port 0A

This feature allows the user to enable Data Direct I/O control for the port specified. The options are Enabled and **Disabled**.

Port 1A, Port 1B, Port 2A, Port 2B, Port 3A

This feature allows the user to enable Data Direct I/O control for the ports specified. The options are **Enabled** and Disabled.

►QPI Configuration**Current QPI Link Speed**

This item displays the current status of the QPI Link.

Current QPI Link Frequency

This item displays the frequency of the QPI Link.

Isoc

Select Enabled to enable Isochronous support to meet QoS (Quality of Service) requirements. This feature is especially important for virtualization technology. The options are Enabled and **Disabled**.

QPI (Quick Path Interconnect) Link Speed Mode

Use this feature to select data transfer speed for QPI Link connections. The options are **Fast** and Slow.

QPI Link Frequency Select

Use this feature to select the desired QPI frequency. The options are **Auto**, 6.4 GT/s, 7.2 GT/s, and 8.0 GT/s.

► DIMM Configuration

This section displays the following DIMM information.

Current Memory Mode

This item displays the current memory mode.

Current Memory Speed

This item displays the current memory speed.

Mirroring

This item displays if memory mirroring is supported by the motherboard. Memory mirroring creates a duplicate copy of the data stored in the memory to enhance data security.

Sparing

This item displays if memory sparing is supported by the motherboard. Memory sparing enhances system performance.

► DIMM Information**CPU Socket 1 DIMM Information/ CPU Socket 2 DIMM Information**

The status of the memory modules detected by the BIOS will be displayed as detected by the BIOS.

Memory Mode

When Independent is selected, all DIMMs are available to the operating system. When Mirroring is selected, the motherboard maintains two identical copies of all data in memory for data backup. When Lockstep is selected, the motherboard uses two areas of memory to run the same set of operations in parallel. The options are **Independent**, Mirroring, and Lockstep.

DRAM RAPL Mode

RAPL (Running Average Power Limit) provides mechanisms to enforce power consumption limits on supported processors. The options are DRAM RAPL MODE0 , **DRAM RAPL MODE1**, and Disabled.

DDR Speed

Use this feature to force a DDR3 memory module to run at a frequency other than what is specified by the manufacturer. The options are **Auto**, Force DDR3-800, Force DDR3-1066, Force DDR3-1333, Force DDR3-1600 and Force SPD.

Channel Interleaving

This feature selects from the different channel interleaving methods. The options are **Auto**, 1 Way, 2 Way, 3, Way, and 4 Way.

Rank Interleaving

This feature allows the user to select a rank memory interleaving method. The options are **Auto**, 1 Way, 2 Way, 4, Way, and 8 Way.

Patrol Scrub

Patrol Scrubbing is a process that allows the CPU to correct correctable memory errors detected on a memory module and send the correction to the requestor (the original source). When this item is set to Enabled, the IO hub will read and write back one cache line every 16K cycles, if there is no delay caused by internal processing. By using this method, roughly 64 GB of memory behind the IO hub will be scrubbed every day. The options are **Enabled** and Disabled.

Demand Scrub

Demand Scrubbing is a process that allows the CPU to correct correctable memory errors found on a memory module. When the CPU or I/O issues a demand-read command, and the read data from memory turns out to be a correctable error, the error is corrected and sent to the requestor (the original source). Memory is updated as well. Select Enabled to use Demand Scrubbing for ECC memory correction. The options are Enabled and **Disabled**.

Data Scrambling

Select Enabled to enable data scrambling to ensure data security and integrity. The options are Disabled and **Enabled**.

Device Tagging

Select Enabled to support device tagging. The options are **Disabled** and Enabled.

Thermal Throttling

Throttling improves reliability and reduces power consumption in the processor via automatic voltage control during processor idle states. The options are Disabled and **CLTT** (Closed Loop Thermal Throttling).

► South Bridge Configuration

This feature allows the user to configure the settings for the Intel PCH chip.

PCH Information

This feature displays the following PCH information.

Name: This item displays the name of the PCH chip.

Stepping: This item displays the PCH stepping.

USB Devices: This item displays the USB devices detected by the BIOS.

All USB Devices

This feature enables all USB ports/devices. The options are Disabled and **Enabled**. (If set to Enabled, EHCI Controller 1 and Controller 2 will appear.)

EHCI Controller 1/EHCI Controller 2 (Available when All USB Devices is set to Enabled)

Select Enabled to enable EHCI (Enhanced Host Controller Interface) Controller 1 or Controller 2. The options are Disabled and **Enabled**.

Legacy USB Support (Available when USB Functions is not Disabled)

Select Enabled to support legacy USB devices. Select Auto to disable legacy support if USB devices are not present. Select Disabled to have USB devices available for EFI (Extensive Firmware Interface) applications only. The settings are Disabled, **Enabled** and Auto.

Port 60/64 Emulation

Select Enabled to enable I/O port 60h/64h emulation support for the legacy USB keyboard so that it can be fully supported by the operating systems that does not recognize a USB device. The options are Disabled and **Enabled**.

EHCI Hand-Off

This item is for operating systems that do not support Enhanced Host Controller Interface (EHCI) hand-off. When enabled, EHCI ownership change will be claimed by the EHCI driver. The options are **Disabled** and Enabled.

► SATA Configuration

When this submenu is selected, the AMI BIOS automatically detects the presence of IDE or SATA devices and displays the following items.

SATA Port0~SATA Port5: The AMI BIOS displays the status of each SATA port as detected by the BIOS.

SATA Mode

Use this feature to configure SATA mode for a selected SATA port. The options are Disabled, IDE Mode, **AHCI Mode** and RAID Mode. The following are displayed depending on your selection:

IDE Mode

The following items are displayed when IDE Mode is selected:

Serial-ATA (SATA) Controller 0~1

Use this feature to activate or deactivate the SATA controller, and set the compatibility mode. The options are Disabled, Enhanced, and Compatible. The default for SATA Controller 0 is **Compatible**. The default of SATA Controller 1 is **Enhanced**.

AHCI Mode

The following items are displayed when the AHCI Mode is selected.

Aggressive Link Power Management

When Enabled, the SATA AHCI controller manages the power usage of the SATA link. The controller will put the link in a low power mode during extended periods of I/O inactivity, and will return the link to an active state when I/O activity resumes. The options are **Enabled** and Disabled.

Port 0~5 Hot Plug

Select Enabled to enable hot-plug support for a particular port, which will allow the user to change a hardware component or device without shutting down the system. The options are **Enabled** and Disabled.

Staggered Spin Up

Select Enabled to enable Staggered Spin-up support to prevent excessive power consumption caused by multiple HDDs spinning-up simultaneously. The options are Enabled and **Disabled**.

RAID Mode

The following items are displayed when RAID Mode is selected:

Port 0~5 Hot Plug

Select Enabled to enable hot-plug support for the particular port. The options are **Enabled** and Disabled.

► SCU (Storage Control Unit) Configuration

Storage Controller Unit

Select Enabled to enable PCH SCU storage devices. The options are Disabled and **Enabled**.

OnChip SCU Option ROM

Select Enabled to support the onboard SCU Option ROM to boot up the system via a storage device. The options are Disabled and **Enabled**.

SCU Port 0~SCU Port 7: The AMI BIOS will automatically detect the onboard SCU devices and display the status of each SCU device as detected.



Note: X9DBL-iF boards only support SATA drives. X9DBL-3F boards support both SATA and SAS drives.

► PCIe/PCI/PnP Configuration

PCI ROM Priority

Use this feature to select the Option ROM to boot the system when there are multiple Option ROMs available in the system. The options are EFI Compatible ROM and **Legacy ROM**.

PCI Latency Timer

Use this feature to set the latency Timer of each PCI device installed on a PCI bus. Select 64 to set the PCI latency to 64 PCI clock cycles. The options are 32, **64**, 96, 128, 160, 192, 224 and 248.

Above 4G Decoding (Available if the system supports 64-bit PCI decoding)

Select Enabled to decode a PCI device that supports 64-bit in the space above 4G Address. The options are Enabled and **Disabled**.

PERR# Generation

Select Enabled to allow a PCI device to generate a PERR number for a PCI Bus Signal Error Event. The options are Enabled and **Disabled**.

SERR# Generation

Select Enabled to allow a PCI device to generate an SERR number for a PCI Bus Signal Error Event. The options are Enabled and **Disabled**.

Maximum Payload

Select Auto to allow the system BIOS to automatically set the maximum payload value for a PCI-E device to enhance system performance. The options are **Auto**, 128 Bytes and 256 Bytes.

Maximum Read Request

Select Auto to allow the system BIOS to automatically set the maximum Read Request size for a PCI-E device to enhance system performance. The options are **Auto**, 128 Bytes, 256 Bytes, 512 Bytes, 1024 Bytes, 2048 Bytes, and 4096 Bytes.

ASPM Support

This feature allows the user to set the Active State Power Management (ASPM) level for a PCI-E device. Select Force L0s to force all PCI-E links to operate at L0s state. Select Auto to allow the system BIOS to automatically set the ASPM level for the system. Select Disabled to disable ASPM support. The options are **Disabled**, Force L0s, and Auto.



Warning: Enabling ASPM support may cause some PCI-E devices to fail!

PCI Slot 1 OPROM, CPU1 Slot 2 PCI-E 3.0 x4 OPROM, CPU2 Slot 3 PCI-E 3.0 x8 OPROM, CPU2 Slot 4 PCI-E 3.0 x8 OPROM, CPU2 Slot 5 PCI-E 3.0 x8 OPROM, CPU1 Slot 6 PCI-E 3.0 x16 OPROM

Select Enabled to enable Option ROM support to boot the computer using a device installed on the slots specified above. The options are **Enabled** and Disabled.

Onboard LAN Option ROM Select

Select iSCSI to use the iSCSI Option ROM to boot the computer using a network device. Select PXE (Preboot Execution Environment) to use an PXE Option ROM to boot the computer using a network device. The options are iSCSI and **PXE**.

Load Onboard LAN1 Option ROM/Load Onboard LAN2 Option ROM

Select Enabled to enable the onboard LAN1 Option ROM~LAN2 Option ROM. This is to boot the computer using a network device. The default setting for LAN1 Option ROM is **Enabled**, and the default setting for LAN2 Option ROM is **Disabled**.

Load Onboard SAS Option ROM

Select Enabled to use the SAS Option ROM to boot the computer using a SAS device. The options are **Enabled** and Disabled.

VGA Priority

This feature allows the user to select the graphics adapter to be used as the primary boot device. The options are **Onboard**, and Offboard.

► Super IO Configuration

Super IO Chip: This item displays the Super IO chip used in the motherboard.

► Serial Port 1 Configuration

Serial Port

Select Enabled to enable a serial port specified by the user. The options are **Enabled** and Disabled.

Device Settings

This item displays the settings of Serial Port 1.

Change Settings

This option specifies the base I/O port address and the Interrupt Request address of Serial Port 1. Select Disabled to prevent the serial port from accessing any system resources. When this option is set to Disabled, the serial port becomes unavailable. The options are **Auto**, IO=3F8h; IRQ=4; IO=3F8h; IRQ=3, 4, 5, 6, 7, 9, 10, 11, 12; IO=2F8h; IRQ=3, 4, 5, 6, 7, 9, 10, 11, 12; IO=3E8h; IRQ=3, 4, 5, 6, 7, 9, 10, 11, 12; and IO=2E8h; IRQ=3, 4, 5, 6, 7, 9, 10, 11, 12;

Device Mode

Use this feature to select the desired mode for a serial port specified. The options are **Normal** and High Speed.

► Serial Port 2 Configuration

Serial Port

Select Enabled to enable a serial port specified by the user. The options are **Enabled** and Disabled.

Device Settings

This item displays the settings of Serial Port 2.

Change Settings

This option specifies the base I/O port address and the Interrupt Request address of Serial Port 1. Select Disabled to prevent the serial port from accessing any system resources. When this option is set to Disabled, the serial port becomes unavailable. The options are **Auto**, IO=3F8h; IRQ=4; IO=3F8h; IRQ=3, 4, 5, 6, 7, 9, 10, 11, 12; IO=2F8h; IRQ=3, 4, 5, 6, 7, 9, 10, 11, 12; IO=3E8h; IRQ=3, 4, 5, 6, 7, 9, 10, 11, 12; and IO=2E8h; IRQ=3, 4, 5, 6, 7, 9, 10, 11, 12;

Device Mode

Use this feature to select the desired mode for a serial port specified. The options are **Normal** and High Speed.

Serial Port 2 Attribute

Use this feature to select the attribute for serial port 2. The options are **SOL** (Serial Over LAN), and COM.

► Serial Port Console Redirection

COM 1/COM 2

These two submenus allow the user to configure the following Console Redirection settings for a COM Port specified by the user.

Console Redirection

Select Enabled to use a COM Port selected by the user for Console Redirection. The options are Enabled and Disabled. The default setting for COM1 is **Disabled**, and for COM2 is **Enabled**.

► Console Redirection Settings

This feature allows the user to specify how the host computer will exchange data with the client computer, which is the remote computer used by the user.

Terminal Type

This feature allows the user to select the target terminal emulation type for Console Redirection. Select VT100 to use the ASCII Character set. Select VT100+ to add color and function key support. Select ANSI to use the Extended ASCII Character Set. Select VT-UTF8 to use UTF8 encoding to map Unicode characters into one or more bytes. The options are ANSI, VT100, **VT100+**, and VT-UTF8.

Bits Per second

Use this feature to set the transmission speed for a serial port used in Console Redirection. Make sure that the same speed is used in the host computer and the client computer. A lower transmission speed may be required for long and busy lines. The options are 9600, 19200, 38400, 57600 and **115200** (bits per second).

Data Bits

Use this feature to set the data transmission size for Console Redirection. The options are 7 Bits and **8 Bits**.

Parity

A parity bit can be sent along with regular data bits to detect data transmission errors. Select Even if the parity bit is set to 0, and the number of 1's in data bits is even. Select Odd if the parity bit is set to 0, and the number of 1's in data bits is odd. Select None if you do not want to send a parity bit with your data bits in transmission. Select Mark to add a mark as a parity bit to be sent along with the data bits. Select Space to add a Space as a parity bit to be sent with your data bits. The options are **None**, Even, Odd, Mark and Space.

Stop Bits

A stop bit indicates the end of a serial data packet. Select 1 Stop Bit for standard serial data communication. Select 2 Stop Bits if slower devices are used. The options are 1 and 2.

Flow Control

This feature allows the user to set the flow control for Console Redirection to prevent data loss caused by buffer overflow. Send a "Stop" signal to stop sending data when the receiving buffer is full. Send a "Start" signal to start sending data when the receiving buffer is empty. The options are **None** and Hardware RTS/CTS.

VT-UTF8 Combo Key Support

Select Enabled to enable VT-UTF8 Combination Key support for ANSI/VT100 terminals. The options are **Enabled** and Disabled.

Recorder Mode

Select Enabled to capture the data displayed on a terminal and send it as text messages to a remote server. The options are **Disabled** and Enabled.

Resolution 100x31

Select Enabled for extended-terminal resolution support. The options are Disabled and **Enabled**.

Legacy OS Redirection Resolution

Use this feature to select the number of rows and columns used in Console Redirection for legacy OS support. The options are 80x24 and **80x25**.

Putty KeyPad

This feature selects Function Keys and KeyPad settings for Putty, which is a terminal emulator designed for the Windows OS. The options are **VT100**, LINUX, XTERMR6, SC0, ESCN, and VT400.

Serial Port for Out-of-Band Management/Windows Emergency Management Services (EMS)

The submenu allows the user to configure Console Redirection settings to support Out-of-Band Serial Port management.

Console Redirection (for EMS)

Select Enabled to use a COM Port selected by the user for Console Redirection. The options are Enabled and **Disabled**.

►Console Redirection Settings (for EMS)

This feature allows the user to specify how the host computer will exchange data with the client computer, which is the remote computer used by the user.

Out-of-Band Management Port

The feature selects a serial port used by the Microsoft Windows Emergency Management Services (EMS) to communicate with a remote server. The options are **COM1** and COM2.

Terminal Type

This feature allows the user to select the target terminal emulation type for Console Redirection. Select VT100 to use the ASCII character set. Select VT100+ to add color and function key support. Select ANSI to use the extended ASCII character set. Select VT-UTF8 to use UTF8 encoding to map Unicode characters into one or more bytes. The options are ANSI, VT100, **VT100+**, and VT-UTF8.

Bits Per Second

This item sets the transmission speed for a serial port used in Console Redirection. Make sure that the same speed is used in the host computer and the client computer. A lower transmission speed may be required for long and busy lines. The options are 9600, 19200, 57600, and **115200** (bits per second).

Flow Control

This feature allows the user to set the flow control for Console Redirection to prevent data loss caused by buffer overflow. Send a "Stop" signal to stop sending data when the receiving buffer is full. Send a "Start" signal to start sending data when the receiving buffer is empty. The options are **None**, Hardware RTS/CTS, and Software Xon/Xoff.

Data Bits, Parity, Stop Bits

The status of these features is displayed.

►ACPI Settings

Use this feature to configure Advanced Configuration and Power Interface (ACPI) power management settings for your system.

ACPI Sleep State

Use this feature to select the ACPI State when the system is in sleep mode. Select S1 (CPU Stop Clock) to erase all CPU caches and stop executing instructions. Power to the CPU(s) and RAM is maintained, but RAM is refreshed. Select Suspend Disabled to use power-reduced mode. Power will only be supplied to limited components (such as RAMs) to maintain the most critical functions of the system. The options are **S1 (CPU Stop Clock)**, and Suspend Disabled.

NUMA (NON-Uniform Memory Access)

This feature enables the Non-Uniform Memory Access ACPI support. The options are **Enabled** and Disabled.

High Precision Event Timer

Select Enabled to activate the High Precision Event Timer (HPET) that produces periodic interrupts at a much higher frequency than a Real-time Clock (RTC) does in synchronizing multimedia streams, providing smooth playback, reducing the dependency on other timestamp calculation devices, such as an x86 RDTSC Instruction embedded in the CPU. The High Performance Event Timer is used to replace the 8254 Programmable Interval Timer. The options are **Enabled** and Disabled.

► Trusted Computing (Available when a TPM device is detected by the BIOS)

Configuration

TPM Support

Select Enabled on this item and enable the TPM jumper on the motherboard to enable TPM support to improve data integrity and network security. The options are **Enabled** and Disabled.

TPM State

Select Enabled to enable TPM security settings to improve data integrity and network security. The options are Disabled and **Enabled**.

Pending Operation

Use this item to schedule an operation for the security device. The options are **None**, Enable Take Ownership, Disable Take Ownership, and TPM Clear.

 **Note:** During restart, the computer will reboot in order to execute the pending operation and change the state of the security device.

Current Status Information: This item displays the information regarding the current TPM status.

TPM Enable Status

This item displays the status of TPM Support to indicate if TPM is currently enabled or disabled.

TPM Active Status

This item displays the status of TPM Support to indicate if TPM is currently active or deactivated.

TPM Owner Status

This item displays the status of TPM Ownership.

► Intel TXT (LT-SX) Configuration

Intel TXT (LT-SX) Hardware Support

This feature indicates if the following hardware components support the Intel Trusted Execution Technology.

CPU: TXT (Trusted Execution Technology) Feature

Chipset: TXT (Trusted Execution Technology) Feature

Intel TXT (LT-SX) Configuration

This feature displays the following TXT configuration setting.

TXT (LT-SX) Support: This item indicates if the Intel TXT support is enabled or disabled. The default setting is **Disabled**.

Intel TXT (LT-SX) Dependencies

This feature displays the features that need to be enabled for the Intel Trusted Execution Technology to work properly in the system.

VT-d Support: Intel Virtualization Technology with Direct I/O support

VT Support: Intel Virtualization Technology support

TPM Support: Trusted Platform support

TPM State: Trusted Platform state

► ME Subsystem

This feature displays the following ME Subsystem Configuration settings.

- **ME BIOS Interface Version**
- **ME Version**

7-4 Event Logs

Use this feature to configure Event Log settings.

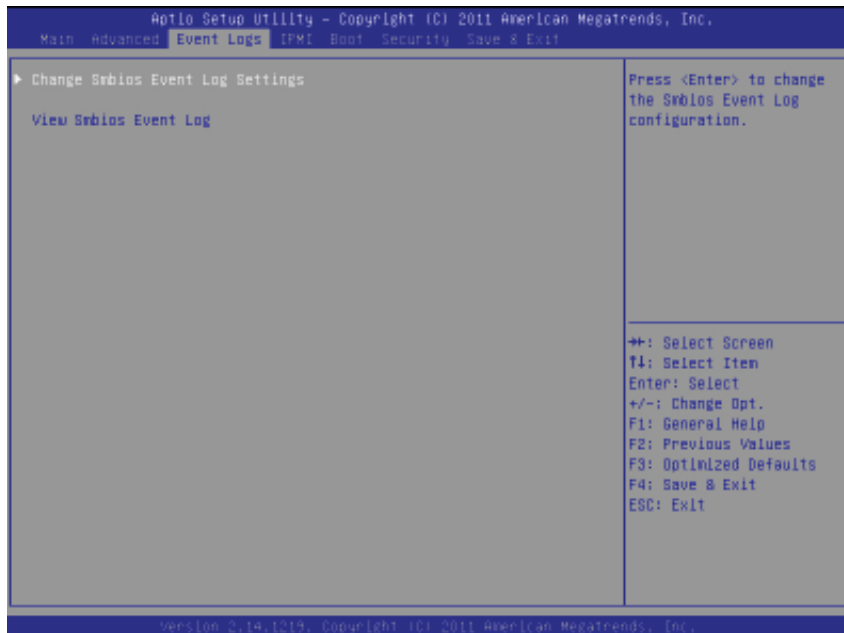

► Change SMBIOS Event Log Settings

This feature allows the user to configure SMBIOS Event settings.

Enabling/Disabling Options

SMBIOS Event Log

Select Enabled to enable SMBIOS (System Management BIOS) Event Logging during system boot. The options are **Enabled** and Disabled.

Runtime Error Logging Support

Select Enabled to support Runtime Error Logging. The options are **Enabled** and Disabled.

Memory Correctable Error Threshold

This feature allows the user to enter the threshold value for correctable memory errors. The default setting is **10**.

PCI Error Logging Support

Select Enabled to support error event logging for PCI slots. The options are Enabled and **Disabled**.

Erasing Settings

Erase Event Log

Select Enabled to erase the SMBIOS (System Management BIOS) Event Log, which is completed before an event logging is initialized upon system reboot. The options are **No**, Yes, next reset, and Yes, every reset.

When Log is Full

Select Erase Immediately to immediately erase SMBIOS error event logs that exceed the limit when the SMBIOS event log is full. Select Do Nothing for the system to do nothing when the SMBIOS event log is full. The options are **Do Nothing** and Erase Immediately.

SMBIOS Event Log Standard Settings

Log System Boot Event

Select Enabled to log system boot events. The options are **Disabled** and Enabled.

MECI (Multiple Event Count Increment)

Enter the increment value for the multiple event counter. Enter a number from 1 to 255. The default setting is **1**.

METW (Multiple Event Count Time Window)

This item allows the user to decide how long (in minutes) should the multiple event counter wait before generating a new event log. Enter a number from 0 to 99. The default setting is **60**.

View SMBIOS Event Log

This item allows the user to view the event in the SMBIOS event log. Select this item and press <Enter> to view the status of an event in the log.

Date/Time/Error Code/Severity

7-5 IPMI

Use this feature to configure Intelligent Platform Management Interface (IPMI) settings.

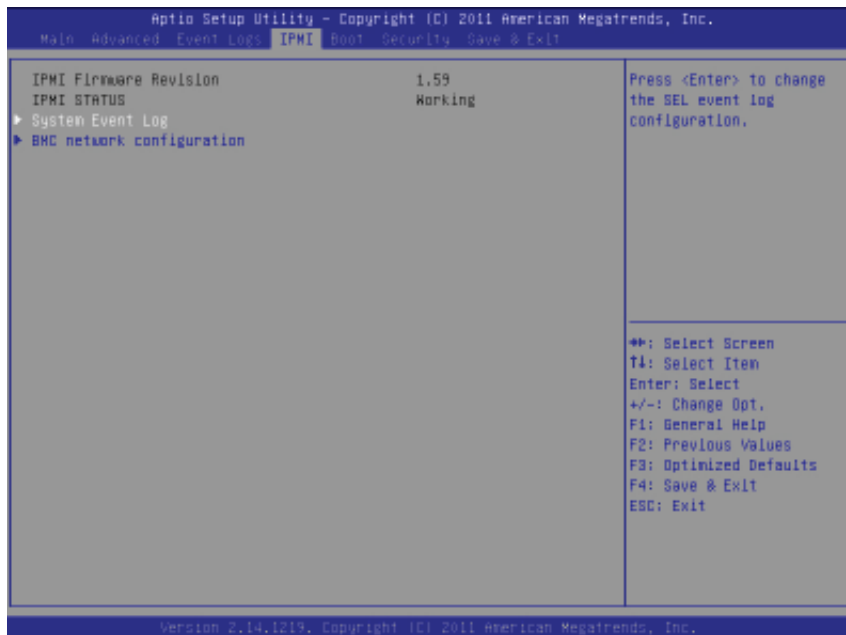

IPMI Firmware Revision

This item indicates the IPMI firmware revision used in your system.

IPMI Status

This item indicates the status of the IPMI firmware installed in your system.

▶ System Event Log

Enabling/Disabling Options

SEL Components

Select Enabled for all system event logging at bootup. The options are **Enabled** and Disabled.

Erasing Settings

Erase SEL

Select Yes, On next reset to erase all system event logs upon next system reboot.
 Select Yes, On every reset to erase all system event logs upon each system reboot.
 Select No to keep all system event logs after each system reboot. The options are **No**, Yes, On next reset, and Yes, On every reset.

When SEL is Full

This feature allows the user to decide what the BIOS should do when the system event log is full. Select Erase Immediately to erase all events in the log when the system event log is full. The options are **Do Nothing** and Erase Immediately.

Custom EFI Logging Options

Log EFI Status Codes

Select Enabled to log EFI (Extensible Firmware Interface) Status Codes, Error Codes or Progress Codes. The options are **Enabled** and Disabled.



Note: After making changes on a setting, be sure to reboot the system for the changes to take effect.

►BMC Network Configuration

LAN Channel 1: This feature allows the user to configure the settings for LAN1 Port.

Update IPMI LAN Configuration

This feature allows the BIOS to implement any IP/MAC address changes at the next system boot. If the option is set to Yes, any changes made to the settings below will take effect when the system is rebooted. The options are **No** and Yes.

Configuration Address Source

This feature allows the user to select the source of the IP address for this computer. If Static is selected, you will need to know the IP address of this computer and enter it to the system manually in the field. If DHCP is selected, the BIOS will search for a DHCP (Dynamic Host Configuration Protocol) server in the network that is attached to and request the next available IP address for this computer. The options are **DHCP** and Static. The following items are assigned IP addresses automatically if DHCP is selected, or can be configured manually if Static is selected.

Station IP Address

This item displays the Station IP address for this computer. This should be in decimal and in dotted quad form (i.e., 192.168.10.253).

Subnet Mask

This item displays the sub-network that this computer belongs to. The value of each three-digit number separated by dots should not exceed 255.

Station MAC Address

This item displays the Station MAC address for this computer. Mac addresses are 6 two-digit hexadecimal numbers.

Gateway IP Address

This item displays the Gateway IP address for this computer. This should be in decimal and in dotted quad form (i.e., 192.168.10.253).

7-6 Boot

This submenu allows the user to configure the following boot settings for the system.



Boot Option Priorities

Boot Option #1/ Boot Option #2/ Boot Option #3, etc.

Use this feature to specify the sequence of boot device priority.

Network Devices, Hard Disk Drives

This option sets the order of the legacy network and hard disk devices detected by the motherboard.

Add New Boot Option

This feature allows the user to add a new EFI boot option to the boot order.

►Delete Boot Option

Use this feature to select a boot device to delete from the boot priority list.

Delete Boot Option

Select the desired boot device to delete.

7-7 Security

This menu allows the user to configure the following security settings for the system.

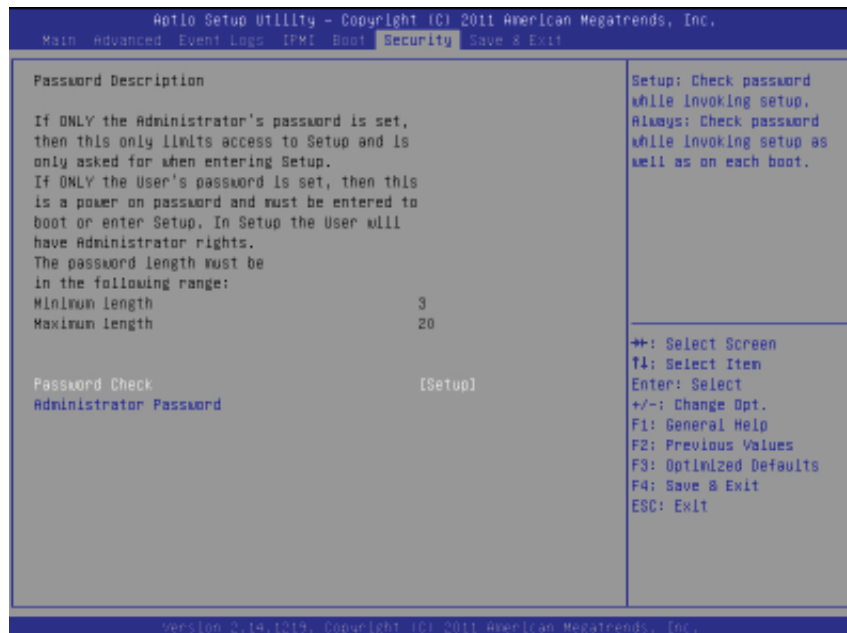

Administrator Password

Use this feature to set the Administrator Password which is required to enter the BIOS setup utility. The length of the password should be from 3 characters to 20 characters long.

User Password

Use this feature to set a User Password which is required to log into the system and to enter the BIOS setup utility. The length of the password should be from 3 characters to 20 characters long.

7-8 Save & Exit

This submenu allows the user to configure the Save and Exit settings for the system.

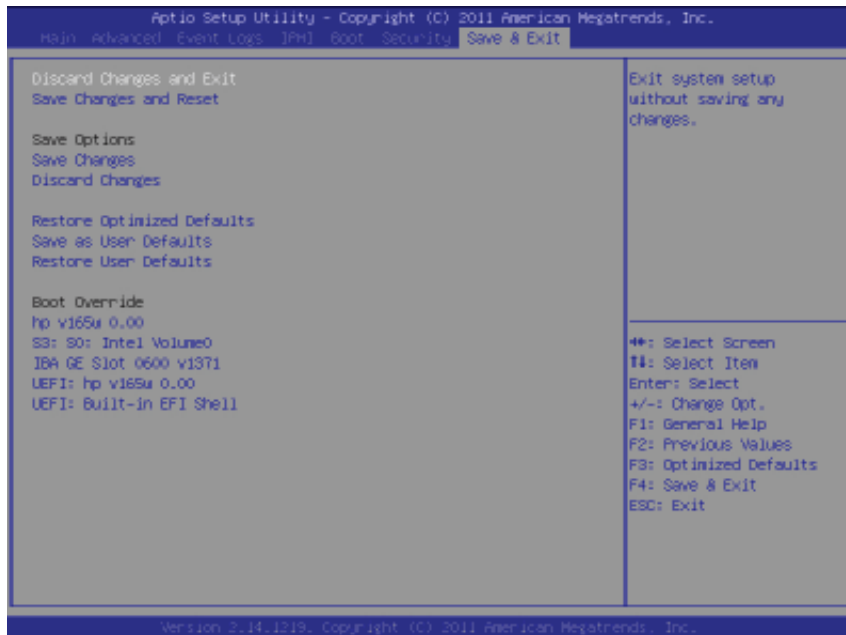

Discard Changes and Exit

Select this option to quit the BIOS Setup without making any permanent changes to the system configuration, and reboot the computer. Select Discard Changes and Exit, and press <Enter>. When the dialog box appears, asking you if you want to exit the BIOS setup without saving, select **Yes** to quit BIOS without saving the changes, or select No to quit the BIOS and save changes.

Save Changes and Reset

When you have completed the system configuration changes, select this option to save the changes and reboot the computer so that the new system configuration settings can take effect. Select Save Changes and Exit, and press <Enter>. When the dialog box appears, asking you if you want to exit the BIOS setup without saving, select **Yes** to quit BIOS without saving the changes, or select No to quit the BIOS and save changes.

Save Options

Save Changes

Select this option and press <Enter> to save all changes you've done so far and return to the AMI BIOS utility Program. When the dialog box appears, asking you if you want to save configuration, select **Yes** to save the changes, or select No to return to the BIOS without making changes.

Discard Changes

Select this feature and press <Enter> to discard all the changes and return to the BIOS setup. When the dialog box appears, asking you if you want to load previous values, select **Yes** to load the values previous saved, or select No to keep the changes you've made so far.

Restore Optimized Defaults

Select this feature and press <Enter> to load the optimized default settings that help optimize system performance. When the dialog box appears, asking you if you want to load optimized defaults, select **Yes** to load the optimized default settings, or select No to abandon optimized defaults.

Save as User Defaults

Select this feature and press <Enter> to save the current settings as the user's defaults. When the dialog box appears, asking you if you want to save values as user's defaults, select **Yes** to save the current values as user's default settings, or select No to keep the defaults previously saved as the user's defaults.

Restore User Defaults

Select this feature and press <Enter> to load the user's defaults previously saved in the system. When the dialog box appears, asking you if you want to restore user's defaults, click **Yes** to restore the user's defaults previously saved in the system, or click No to abandon the user's defaults that were previously saved.

Boot Override

This feature allows the user to override the Boot Option Priorities setting in the Boot menu, and instead immediately boot the system with one of the listed devices. This is a one-time override.

Notes

Appendix A

BIOS Error Beep Codes

During the POST (Power-On Self-Test) routines, which are performed at each system boot, errors may occur.

Non-fatal errors are those which, in most cases, allow the system to continue to boot. The error messages normally appear on the screen.

Fatal errors will not allow the system to continue with bootup procedure. If a fatal error occurs, you should consult with your system manufacturer for possible repairs.

These fatal errors are usually communicated through a series of audible beeps. The numbers on the fatal error list correspond to the number of beeps for the corresponding error.

BIOS Error Beep Codes		
Beep Code/LED	Error Message	Description
1 beep	Refresh	Ready to boot
5 short beeps + 1 long beep	Memory error	No memory detected in the system
5 beeps	No Con-In or No Con-Out devices	Con-In: USB or PS/2 keyboard, PCI or Serial Console Redirection, IPMI KVM or SOL Con-Out: Video Controller, PCI or Serial Console Redirection, IPMI SOL
X9 IPMI Error Code		
1 Continuous Beep	System OH	System Overheat

Notes

Appendix B

System Specifications

Processors

Dual Intel® Xeon® E5-2400 Series processors (up to 95W TDP) in an LGA 1356 socket

Note: Please refer to our web site for a complete listing of supported processors.

Chipset

Intel C602

BIOS

64 Mb SPI AMI® Flash

Memory Capacity

Six DIMM sockets that can support up to 192 GB of ECC DDR3-1600/1333/1066/800 R/LRDIMMs (LRDIMM = Reduced Load DIMMs) or up to 48GB of ECC UDIMMs

See the memory section in Chapter 5 for details.

SATA

Intel on-chip controller for two 6 Gb/sec SATA3 ports and four 3 Gb/sec SATA2 ports and , which are RAID 0, 1, 5 and 10 supported (RAID 5 not supported with Linux OS, Windows only)

SATA Drive Bays

Four hot-swap drive bays to house four SATA hard drives

Expansion Slots

Riser card for one PCI-E 3.0/2.0 x16 add-on card

Serverboard

X9DBL-iF

Dimensions: 12 x 10 in (305 x 254 mm)

Chassis

SC813MTQ Form Factor: 1U rackmount

Dimensions: (WxHxD) 17.2 x 1.7 x 19.85 in. (437 x 43 x 504 mm)

Weight

Gross Weight: 36 lbs. (16.4 kg.)

System Cooling

Four 4-cm high performance fans

System Input Requirements

AC Input Voltage: 100-240V AC auto-range

Rated Input Frequency: 50 to 60 Hz

Rated Input Current

6017B-MTF: 5.5-4A (100-140V) to 3.5-2.5A (180-240V)

6017B-MTLF: 4.2-1.8A (100-240V)

6017B-MTRF: 6-3A (100-240V)

Power Supply

6017B-MTF:

Rated Output Power: 440W (Part# PWS-441P-1H)

Rated Output Voltages: +3.3V (15A), +5V (18A), +12V (38.8 at 100-140VAC, 39.1 at 180-240VAC), +5Vsb (3A)

6017B-MTLF:

Rated Output Power: 350W (Part# PWS-351-1H)

Rated Output Voltages: +3.3V (15A), +5V (18A), +12V (29A), -12V (.5A), +5Vsb (3A)

6017B-MTRF (Redundant Power)

Rated Output Power: 440W (Part# PWS-406P-1R)

Rated Output Voltages: +3.3V (25A), +5V (25A), -12V (.6A), +5Vsb (3A)

Operating Environment

Operating Temperature: 10° to 35° C (50° to 95° F)

Non-operating Temperature: -40° to 60° C (-40° to 140° F)

Operating Relative Humidity: 8% to 90% (non-condensing)

Non-operating Relative Humidity: 5 to 95% (non-condensing)

Regulatory Compliance

Electromagnetic Emissions:

FCC Class A, EN 55022 Class A, EN 61000-3-2/-3-3, CISPR 22 Class A

Electromagnetic Immunity:

EN 55024/CISPR 24, (EN 61000-4-2, EN 61000-4-3, EN 61000-4-4,
EN 61000-4-5, EN 61000-4-6, EN 61000-4-8, EN 61000-4-11)

Safety:

EN 60950/IEC 60950-Compliant, UL Listed (USA), CUL Listed (Canada), TUV Certified (Germany), CE Marking (Europe)

California Best Management Practices Regulations for Perchlorate Materials:

This Perchlorate warning applies only to products containing CR (Manganese Dioxide) Lithium coin cells. "Perchlorate Material-special handling may apply. See www.dtsc.ca.gov/hazardouswaste/perchlorate"

Disclaimer (continued from front)

The products sold by Supermicro are not intended for and will not be used in life support systems, medical equipment, nuclear facilities or systems, aircraft, aircraft devices, aircraft/emergency communication devices or other critical systems whose failure to perform be reasonably expected to result in significant injury or loss of life or catastrophic property damage. Accordingly, Supermicro disclaims any and all liability, and should buyer use or sell such products for use in such ultra-hazardous applications, it does so entirely at its own risk. Furthermore, buyer agrees to fully indemnify, defend and hold Supermicro harmless for and against any and all claims, demands, actions, litigation, and proceedings of any kind arising out of or related to such ultra-hazardous use or sale.

Notes