

FTLC9555FEPM-AO

Finisar® FTLC9555FEPM Compatible TAA 100GbE/OTU-4/128G FC Multi-Rate SR4 QSFP28 Transceiver (MMF, 850nm, 100m, MPO, DOM)

Features

- Supports 103.1Gbps and 112.2Gbps Aggregate Bit Rates
- Up to 70m Transmission on MMF OM3, and 100m Transmission on MMF OM4
- Single 3.3V Power Supply and Power Dissipation < 3.5W
- Class 1 FDA and IEC60825-1 Laser Safety Compliant
- I2C Interface with Integrated Digital Diagnostic Monitoring
- Hot-Pluggable QSFP28 Footprint
- RoHS6 Compliant
- Operating Temperature: 0C to +70C



Applications

- 100GBase Ethernet
- Access and Enterprise

Product Description

This Finisar® FTLC9555FEPM compatible QSFP28 transceiver provides 100GBase/OTU4-SR4 throughput up to 100m over OM4 multi-mode fiber (MMF) using a wavelength of 850nm via an MPO connector. It is guaranteed to be 100% compatible with the equivalent Finisar® transceiver. This easy to install, hot swappable transceiver has been programmed, uniquely serialized and data-traffic and application tested to ensure that it will initialize and perform identically. Digital optical monitoring (DOM) support is also present to allow access to real-time operating parameters. This transceiver is Trade Agreements Act (TAA) compliant. We stand behind the quality of our products and proudly offer a limited lifetime warranty.

AddOn's transceivers are RoHS compliant and lead-free.

TAA refers to the Trade Agreements Act (19 U.S.C. & 2501-2581), which is intended to foster fair and open international trade. TAA requires that the U.S. Government may acquire only "U.S. – made or designated country end products."



Regulatory Compliance

Product Certificate	Certificate Number	Applicable Standard
TUV	R50135086	EN 60950-1:2006+A11+A1+A12+A2
		EN 60825-1:2014
		EN 60825-2:2004+A1+A2
UL	E317337	UL 60950-1
		CSA C22.2 No. 60950-1-07
EMC CE	AE 50384190 0001	EN 55032:2012
		EN 55032:2015
		EN 55024:2010
		EN 55024:2010+A1
FCC	WTF14F0514417E	47 CFR PART 15 OCT., 2013
FDA	/	CDRH 1040.10
ROHS	/	2011/65/EU

Absolute Maximum Ratings

Parameter	Symbol	Min.	Typ.	Max.	Unit
Supply Voltage	V _{cc}	-0.5		3.6	V
Storage Temperature	T _s	-40		+85	°C
Case Operating Temperature	T _c	0		70	°C
Operating Relative Humidity	RH	5		85	%

Notes:

1. Exceeding any one of these values may destroy the device immediately.

Electrical Characteristics

Parameter	Symbol	Min.	Typ.	Max.	Unit	Notes
Power Supply Voltage	V _{cc}	3.135	3.3	3.465	V	
Power Consumption	P			3.5	W	
Transmitter						
Input Amplitude (Differential)	V _{in}	150		1050	mVpp	AC coupled inputs
Input Impedance (Differential)	Z _{in}	85	100	115	ohms	R _{in} > 100 kohms @ DC
Receiver						
Output Amplitude (Differential)	V _{out}	200		1100	mVpp	AC coupled outputs
Output Impedance (Differential)	Z _{out}	85	100	115	ohms	
Output Rise/Fall Time	t _r /t _f		12		ps	20%~80%

Optical Characteristics 100GBASE-SR4 Ethernet Operation

Parameter	Symbol	Min.	Typ.	Max.	Unit	Notes	
Transmitter							
Signaling Speed per Lane	BRAVE		25.78		Gbps		
Center Wavelength	λ_C	840	850	860	nm		
Average Launch Power, Each Lane	$P_{out}/lane$	-8.4		2.4	dBm	1	
Optical modulation amplitude	P_{oma}			3	dBm		
Extinction Ratio	ER	3			dB		
Transmitter eye mask definition {X1, X2, X3, Y1, Y2, Y3}		IEEE 802.3bm 100Gbase-SR4					2
Receiver							
Signaling Speed per Lane	BRAVE	25.78		28.05	Gbps		
Center Wavelength	λ_C	840	850	860	nm		
Average Receive Power per Lane	R_{pow}	-10.3		2.4	dBm		
Stressed Receive Sensitivity in OMA per Lane	P_{min}			-5.2	dBm	3	
Receive Sensitivity in OMA per Lane	P_{min}			-8	dBm	3	
LOS Assert	LOSA	-20			dBm		
LOS De-Assert	LOSD			-12	dBm		
LOS Hysteresis		0.5			dB		

Notes:

1. Output is coupled into a 50/125 μ m multi-mode fiber.
2. Filtered, measured with a PRBS $2^{31}-1$ test pattern @25.78Gbps.
3. Receive sensitivity measured at BER less than $5E-5$, with a $2^{31}-1$ PRBS @25.78Gbps.

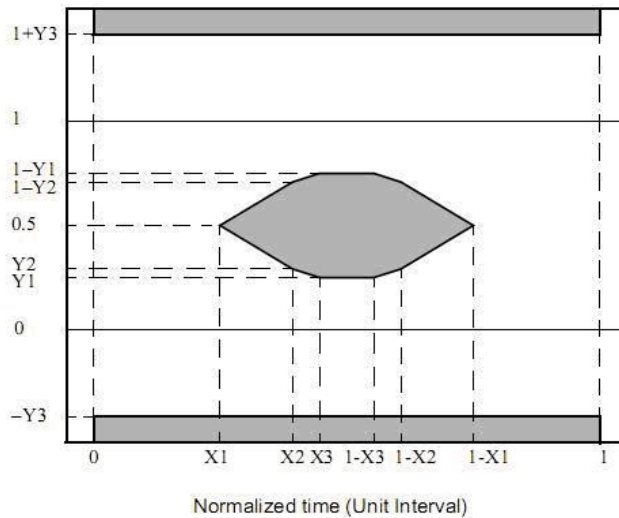

Optical Characteristics OTU4 and 128G Fiber Channel Operation

Parameter	Symbol	Min.	Typ.	Max.	Unit	Notes	
Transmitter							
Signaling Speed per Lane	BRAVE	27.95		28.05	Gbps	1	
Center Wavelength	λ_C	840	850	860	nm		
Average Launch Power, Each Lane	Pout/lane	-2.5		2.4	dBm	2	
Optical modulation amplitude	Poma			3	dBm		
Extinction Ratio	ER	3			dB		
Transmitter eye mask definition {X1, X2, X3, Y1, Y2, Y3}		FC-PI-6					3
Receiver							
Signaling Speed per Lane	BRAVE	27.95		28.05	Gbps		
Center Wavelength	λ_C	840	850	860	nm		
Average Receive Power per Lane	Rpow	-10.2		2.4	dBm		
Receive Sensitivity in OMA per Lane	Pmin			-6	dBm	4	
LOS Assert	LOSA	-20			dBm		
LOS De-Assert	LOSD			-12	dBm		
LOS Hysteresis		0.5			dB		

Notes:

1. This module will work at 103.1Gbps (25.78Gbpsx4) in default. To work at 112.2Gbps (28.05Gbpsx4), Page 00 bytes 87-88 (Rx and Tx Rate Select) need to be written with 0xFF to enable rate select (refer to SFF-8636), which will lose to default when powered off.

Page 00 Byte 87	Page 00 Byte 88	Data Rate
0xAA	0xAA	103.1Gbps (Default)
0xFF	0xFF	112.2Gbps

2. Output is coupled into a 50/125 μ m multi-mode fiber.
3. Filtered, measured with a PRBS $2^{31}-1$ test pattern @28.05Gbps.
4. Receive sensitivity measured at BER less than $1E-6$, with a $2^{31}-1$ PRBS @28.05Gbps.

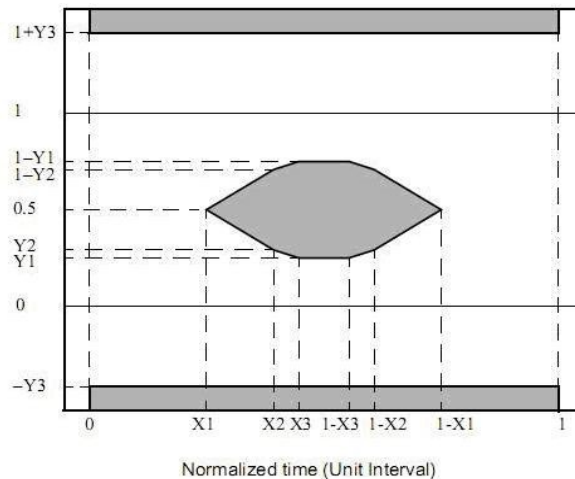

Pin Descriptions

Pin	Logic	Symbol	Name/Descriptions	Ref.
1		GND	Ground	1
2	CML-I	Tx2n	Transmitter Inverted Data Input	
3	CML-I	Tx2p	Transmitter Non-Inverted Data Input	
4		GND	Ground	1
5	CML-I	Tx4n	Transmitter Inverted Data Input	
6	CML-I	Tx4p	Transmitter Non-Inverted Data Input	
7		GND	Ground	1
8	LVTTL-I	ModSelL	Module Select	
9	LVTTL-I	ResetL	Module Reset	
10		VccRx	+3.3V Power Supply Receiver	2
11	LVC MOS- I/O	SCL	2-wire serial interface clock	
12	LVC MOS- I/O	SDA	2-wire serial interface data	
13		GND	Ground	1
14	CML-O	Rx3p	Receiver Non-Inverted Data Output	
15	CML-O	Rx3n	Receiver Inverted Data Output	
16		GND	Ground	1
17	CML-O	Rx1p	Receiver Non-Inverted Data Output	
18	CML-O	Rx1n	Receiver Inverted Data Output	
19		GND	Ground	1
20		GND	Ground	1
21	CML-O	Rx2n	Receiver Inverted Data Output	
22	CML-O	Rx2p	Receiver Non-Inverted Data Output	
23		GND	Ground	1
24	CML-O	Rx4n	Receiver Inverted Data Output	
25	CML-O	Rx4p	Receiver Non-Inverted Data Output	
26		GND	Ground	1
27	LVTTL-O	ModPrsL	Module Present	
28	LVTTL-O	IntL	Interrupt	
29		VccTx	+3.3V Power supply transmitter	2
30		Vcc1	+3.3V Power supply	2
31	LVTTL-I	LPMODE	Low Power Mode	
32		GND	Ground	1
33	CML-I	Tx3p	Transmitter Non-Inverted Data Input	
34	CML-I	Tx3n	Transmitter Inverted Data Input	
35		GND	Ground	1
36	CML-I	Tx1p	Transmitter Non-Inverted Data Input	
37	CML-I	Tx1n	Transmitter Inverted Data Input	
38		GND	Ground	1

Notes:

1. GND is the symbol for signal and supply (power) common for the QSFP28 module. All are common within the QSFP28 module and all module voltages are referenced to this potential unless otherwise noted. Connect these directly to the host board signal-common ground plane.
2. Vcc Rx, Vcc1 and Vcc Tx are the receiver and transmitter power supplies and shall be applied concurrently. Vcc Rx, Vcc1 and Vcc Tx may be internally connected within the QSFP28 Module in any combination. The connector pins are each rated for a maximum current of 500mA.

Electrical Pin-out Details

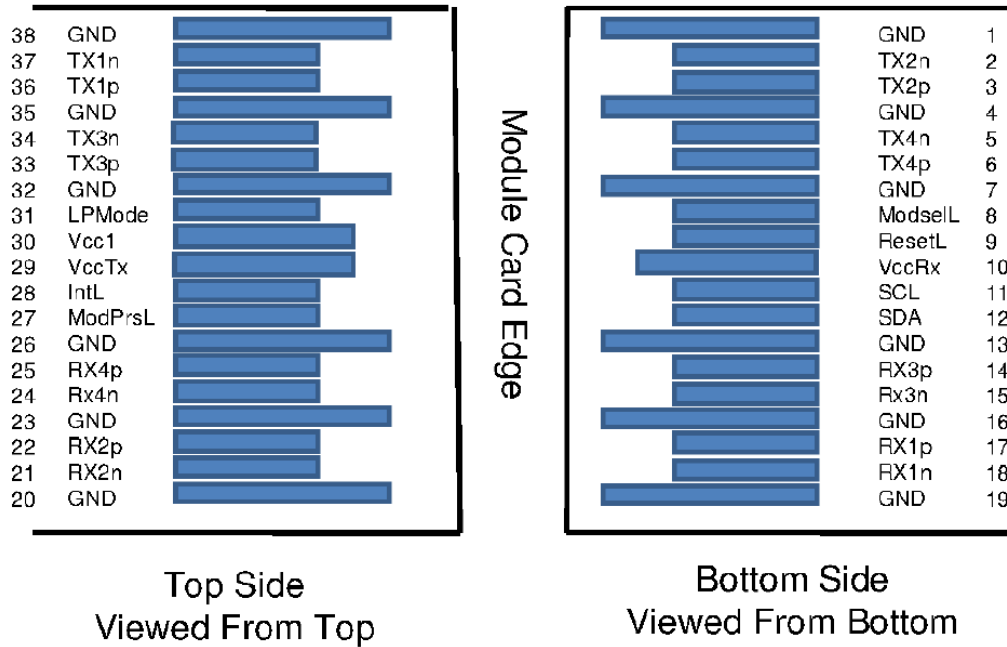

Mechanical Specifications

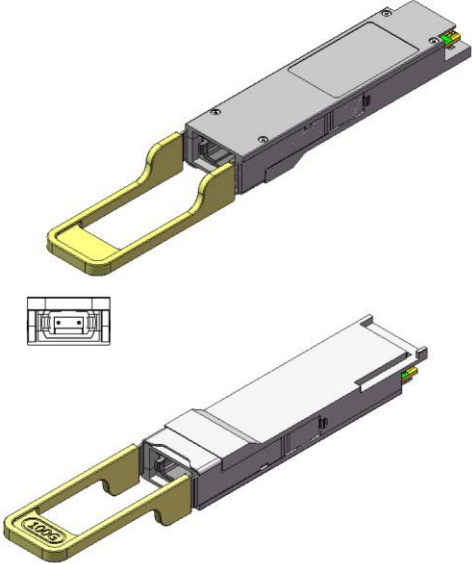
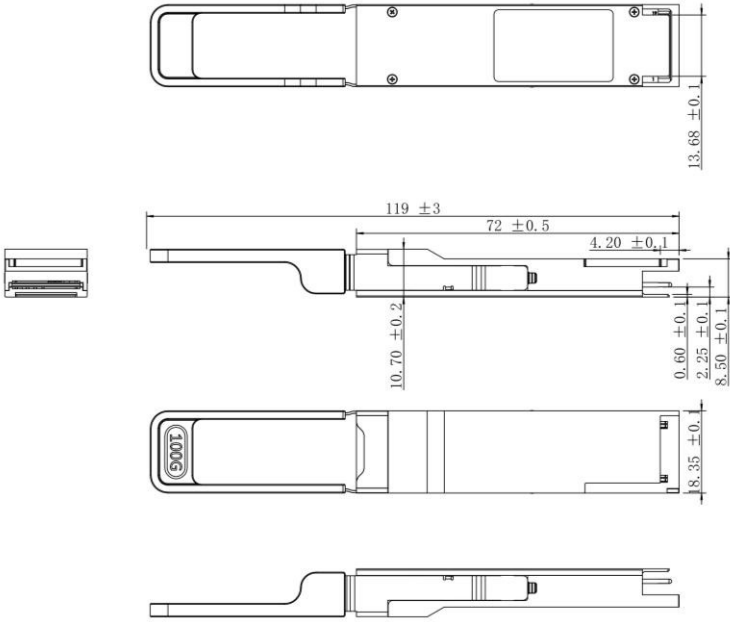

Unit:mm

About AddOn Networks

In 1999, AddOn Networks entered the market with a single product. Our founders fulfilled a severe shortage for compatible, cost-effective optical transceivers that compete at the same performance levels as leading OEM manufacturers. Adhering to the idea of redefining service and product quality not previously had in the fiber optic networking industry, AddOn invested resources in solution design, production, fulfillment, and global support.

Combining one of the most extensive and stringent testing processes in the industry, an exceptional free tech support center, and a consistent roll-out of innovative technologies, AddOn has continually set industry standards of quality and reliability throughout its history.

Reliability is the cornerstone of any optical fiber network and is engrained in AddOn's DNA. It has played a key role in nurturing the long-term relationships developed over the years with customers. AddOn remains committed to exceeding industry standards with certifications from ranging from NEBS Level 3 to ISO 9001:2005 with every new development while maintaining the signature reliability of its products.

U.S. Headquarters

Email: sales@addonnetworks.com

Telephone: +1 877.292.1701

Fax: 949.266.9273

Europe Headquarters

Email: salesupportemea@addonnetworks.com

Telephone: +44 1285 842070