

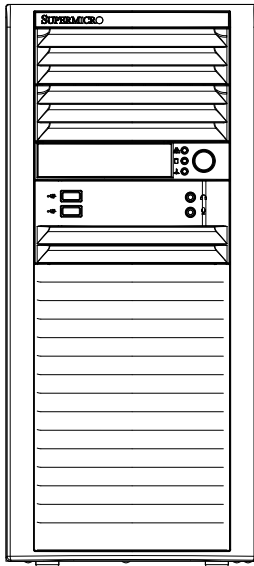

SuperWorkstation

5038A-I



USER'S MANUAL

1.0

The information in this User's Manual has been carefully reviewed and is believed to be accurate. The vendor assumes no responsibility for any inaccuracies that may be contained in this document, makes no commitment to update or to keep current the information in this manual, or to notify any person or organization of the updates. **Please Note: For the most up-to-date version of this manual, please see our web site at www.supermicro.com.**

Super Micro Computer, Inc. ("Supermicro") reserves the right to make changes to the product described in this manual at any time and without notice. This product, including software and documentation, is the property of Supermicro and/or its licensors, and is supplied only under a license. Any use or reproduction of this product is not allowed, except as expressly permitted by the terms of said license.

IN NO EVENT WILL SUPERMICRO BE LIABLE FOR DIRECT, INDIRECT, SPECIAL, INCIDENTAL, SPECULATIVE OR CONSEQUENTIAL DAMAGES ARISING FROM THE USE OR INABILITY TO USE THIS PRODUCT OR DOCUMENTATION, EVEN IF ADVISED OF THE POSSIBILITY OF SUCH DAMAGES. IN PARTICULAR, SUPERMICRO SHALL NOT HAVE LIABILITY FOR ANY HARDWARE, SOFTWARE, OR DATA STORED OR USED WITH THE PRODUCT, INCLUDING THE COSTS OF REPAIRING, REPLACING, INTEGRATING, INSTALLING OR RECOVERING SUCH HARDWARE, SOFTWARE, OR DATA.

Any disputes arising between manufacturer and customer shall be governed by the laws of Santa Clara County in the State of California, USA. The State of California, County of Santa Clara shall be the exclusive venue for the resolution of any such disputes. Super Micro's total liability for all claims will not exceed the price paid for the hardware product.

FCC Statement: This equipment has been tested and found to comply with the limits for a Class A digital device pursuant to Part 15 of the FCC Rules. These limits are designed to provide reasonable protection against harmful interference when the equipment is operated in a commercial environment. This equipment generates, uses, and can radiate radio frequency energy and, if not installed and used in accordance with the manufacturer's instruction manual, may cause harmful interference with radio communications. Operation of this equipment in a residential area is likely to cause harmful interference, in which case you will be required to correct the interference at your own expense.

California Best Management Practices Regulations for Perchlorate Materials: This Perchlorate warning applies only to products containing CR (Manganese Dioxide) Lithium coin cells. "Perchlorate Material-special handling may apply. See www.dtsc.ca.gov/hazardouswaste/perchlorate"

WARNING: Handling of lead solder materials used in this product may expose you to lead, a chemical known to the State of California to cause birth defects and other reproductive harm.

Manual Revision 1.0
Release Date: March 26, 2015

Unless you request and receive written permission from Super Micro Computer, Inc., you may not copy any part of this document.

Information in this document is subject to change without notice. Other products and companies referred to herein are trademarks or registered trademarks of their respective companies or mark holders.

Copyright © 2015 by Super Micro Computer, Inc.
All rights reserved.
Printed in the United States of America

Preface

About This Manual

This manual is written for professional system integrators and PC technicians. It provides information for the installation and use of the SuperWorkstation 5038A-I. Installation and maintenance should be performed by experienced technicians only.

The SuperWorkstation 5038A-I is a high-end system based on the SC732D3-903B mid-tower chassis and the X10SRA motherboard.

Manual Organization

Chapter 1: Introduction

The first chapter provides a list of the main components included with the system and describes the main features of the X10SRA motherboard and the SC732D3-903B chassis.

Chapter 2: Server Installation

This chapter describes the steps necessary to set up the SuperWorkstation 5038A-I and to check out the server configuration prior to powering-up the system. If your system was ordered without processor and memory components, this chapter will refer you to the appropriate sections of the manual for their installation.

Chapter 3: System Interface

Refer here for details on the system interface, which includes the functions and information provided by the control panel on the chassis as well as other LEDs located throughout the system.

Chapter 4: Warning Statements

You should thoroughly familiarize yourself with this chapter for a general overview of safety precautions that should be followed when installing and servicing the SuperWorkstation 5038A-I.

Chapter 5: Advanced Motherboard Setup

Chapter 5 provides detailed information on the X10SRA motherboard, including the locations and functions of connections, headers and jumpers. Refer to this chapter when adding or removing processors or main memory and when reconfiguring the motherboard.

Chapter 6: Advanced Chassis Setup

Refer to Chapter 6 for detailed information on the SC732D3-903B chassis. You should follow the procedures given in this chapter when installing, removing or reconfiguring SATA or peripheral drives and when replacing system power supply units and cooling fans.

Chapter 7: BIOS

The BIOS chapter includes an introduction to BIOS and provides detailed information on running the CMOS Setup Utility.

Appendix A: BIOS Error Beep Codes

Appendix B: Dual Boot Block

Appendix C: System Specifications

Notes

Table of Contents

Chapter 1 Introduction

1-1	Overview	1-1
1-2	Motherboard Features.....	1-2
	Processors	1-2
	Memory	1-2
	SATA	1-2
	PCI Expansion Slots	1-2
	Onboard Controllers/Ports	1-2
1-3	Chassis Features	1-3
	System Power.....	1-3
	SATA Support.....	1-3
	Front Control Panel.....	1-3
	Cooling System.....	1-3
1-4	Contacting Supermicro.....	1-5

Chapter 2 Installation

2-1	Overview	2-1
2-2	Unpacking the System.....	2-1

Chapter 3 System Interface

3-1	Overview	3-1
3-2	Control Panel Buttons	3-1
	Power	3-1
3-3	Control Panel LEDs	3-1
	NIC	3-1
	HDD.....	3-2
	Information LED	3-2

Chapter 4 Standardized Warning Statements for AC Systems

4-1	About Standardized Warning Statements	4-1
	Warning Definition	4-1
	Installation Instructions.....	4-4
	Circuit Breaker	4-5
	Power Disconnection Warning.....	4-6
	Equipment Installation.....	4-8
	Restricted Area.....	4-9
	Battery Handling.....	4-10
	Redundant Power Supplies	4-12

Backplane Voltage	4-13
Comply with Local and National Electrical Codes	4-14
Product Disposal	4-15
Hot Swap Fan Warning	4-16
Power Cable and AC Adapter	4-18
Chapter 5 Advanced Motherboard Setup	
5-1 Handling the Motherboard	5-1
Cautions	5-1
5-2 Connecting Cables	5-2
Connecting Data Cables	5-2
Connecting Power Cables	5-2
Connecting the Control Panel	5-2
5-3 Rear I/O Ports	5-3
5-4 Processor and Heatsink Installation	5-4
Installing an LGA 2011 Processor	5-4
Installing a CPU Heatsink	5-7
Removing the Heatsink	5-8
5-5 Installing Memory Modules	5-9
Memory Population Guidelines	5-10
5-6 Adding PCI Add-On Cards	5-11
5-7 Motherboard Details	5-12
X10SRA Quick Reference	5-12
5-8 Connector Definitions	5-14
5-9 Jumper Settings	5-20
5-10 Onboard Indicators	5-23
5-11 SATA Ports	5-24
5-12 Installing Software	5-25
SuperDoctor® 5	5-26
5-13 Onboard Battery	5-27
Chapter 6 Advanced Chassis Setup	
6-1 Static-Sensitive Devices	6-1
Cautions	6-1
6-2 Removing the Power Cord	6-2
6-3 Front Control Panel	6-4
6-4 Removing the Chassis Side Covers	6-5
6-5 System Fans	6-6
Fan Failure	6-6
Replacing Optional Chassis Cooling Fans	6-6
6-6 Drive Installation	6-8

6-7	Removing and Installing Optional 2.5" Hard Drives	6-11
6-8	Power Supply	6-13

Chapter 7 BIOS

7-1	Introduction.....	7-1
	Starting BIOS GUI Setup Utility	7-1
	How To Change the Configuration Data	7-2
	How to Start the Setup Utility	7-2
7-2	Setup Home	7-3
7-3	System Information	7-6
7-4	Processor (CPU).....	7-10
7-5	Chipset	7-15
7-6	Memory	7-19
7-7	Hardware Monitor.....	7-21
7-8	I/O.....	7-24
4-9	Booting	7-35
7-10	Management	7-44
7-11	IPMI	7-50
4-12	Network Stack.....	7-53
4-13	Event Logs.....	7-56

Appendix A BIOS Error Beep Codes

Appendix B Dual Boot Block

Appendix C System Specifications

Chapter 1

Introduction

1-1 Overview

The 5038A-I is a high-end workstation comprised of two main subsystems: the SC732D3-903B mid-tower/3U chassis and the X10SRA Intel® Xeon® processor motherboard. Please refer to our website for information on operating systems that have been certified for use with the SuperWorkstation 5038A-I.

In addition to the motherboard and chassis, various hardware components have been included with the 5038A-I, as listed below:

- One 12 cm exhaust fan (FAN-0124L4)
- SATA Accessories
Four 3.5" SATA drive bays in a 90° rotating hard drive cage
- Optional:
Four 2.5" HDD/SSD drives
SATA cable (CBL-179L)
Active CPU heatsinks (SNK-P0050AP4)
SATA power adapter (CBL-0082L)
Black 5.25" LCD tray, supports 1x 3.5" HDD (MCP-220-00095-0B)
HDD/SDD drive cage (MCP-220-73201-0N) supporting four 2.5" HDDs.
One 12-cm "Whisper Quiet" system cooling fan

Note: For your system to work properly, please follow the links below to download all necessary drivers/utilities and the user's manual for your server.

- Supermicro product manuals: <http://www.supermicro.com/support/manuals/>
- Product drivers and utilities: <ftp://ftp.supermicro.com>
- Product safety info: http://super-dev/about/policies/safety_information.cfm
- If you have any questions, please contact our support team at: support@supermicro.com

1-2 Motherboard Features

At the heart of the SuperWorkstation 5038A-I lies the X10SRA, a single processor motherboard based on the Intel® C612 Express chipset. Below are the main features of the X10SRA. (See Figure 1-1 for a block diagram of the chipset).

Processors

The X10SRA supports a single Intel Xeon E5-2600/1600 v3 family or Intel Core™ i7 Series processor in an LGA2011-3 socket. Please refer to the motherboard description pages on our website for a complete listing of supported processors (www.supermicro.com).

Memory

The X10SRA features up to 512GB of ECC LRDIMM, 256GB of ECC RDIMM, or 64GB of ECC/non-ECC UDIMM DDR4-2133/1866/1600/1333 memory in eight DIMM slots. See Chapter 5 for details.

SATA

A SATA controller is integrated into the chipset to provide a ten-port SATA 3.0 sub-system. The 5038A-I (X10SRA) supports ten SATA 3.0 ports.

PCI Expansion Slots

The X10SRA features four PCI-Express 3.0 x16 expansion slots.

Onboard Controllers/Ports

The rear I/O panel includes six USB 3.0 ports, one PS/2 mouse/keyboard port, a VGA port, two RJ45 Gb Ethernet LAN ports and 7.1 HD audio jacks.

1-3 Chassis Features

The 5038A-I is a mid-tower chassis with Whisper Quiet operation. The following is a general outline of the main features of the SC743D3-903B chassis.

System Power

The 5038A-I features a single 900W Gold Level multi-outlet power supply with PMBus, ideal for use in a workstation environment.

SATA Support

The SC732D3-903B chassis was designed to support four 3.5" SATA hard drives and four optional 2.5" hard drives.

Front Control Panel

The control panel on the 5038A-I provides you with system monitoring and control. LEDs indicate system power, HDD activity, network activity, overheat conditions and power supply failure. A main power button is also included.

Note: The power supply fail LED indicates the power supply fan has failed.

Cooling System

The SC732D3-903B chassis has an innovative "Whisper Quiet" cooling design that provides sufficient cooling at very low noise level for a workplace environment. The chassis includes one 12-cm exhaust fan located at the rear of the chassis and one 12-cm optional system cooling fan in the middle of the chassis.

The power supply has one internal fan for redundancy; if this fan fails, the power supply must be replaced. See details in Chapter 6.

**Figure 1-1. Intel C612 Express Chipset:
System Block Diagram**

Note: This is a general block diagram. Please see Chapter 5 for details.

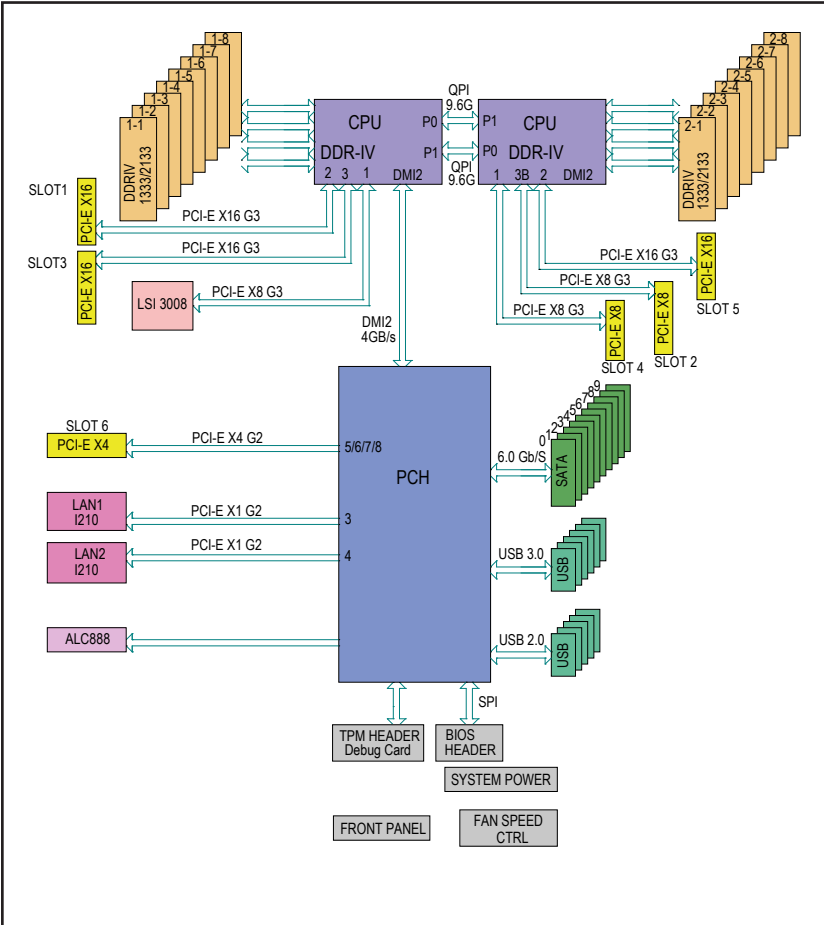

1-4 Contacting Supermicro

Headquarters

Address: Super Micro Computer, Inc.
980 Rock Ave.
San Jose, CA 95131 U.S.A.

Tel: +1 (408) 503-8000

Fax: +1 (408) 503-8008

Email: marketing@supermicro.com (General Information)
support@supermicro.com (Technical Support)

Website: www.supermicro.com

Europe

Address: Super Micro Computer B.V.
Het Sterrenbeeld 28, 5215 ML
's-Hertogenbosch, The Netherlands

Tel: +31 (0) 73-6400390

Fax: +31 (0) 73-6416525

Email: sales@supermicro.nl (General Information)
support@supermicro.nl (Technical Support)
rma@supermicro.nl (Customer Support)

Website: www.supermicro.nl

Asia-Pacific

Address: Super Micro Computer, Inc.
3F, No. 150, Jian 1st Rd.
Zhonghe Dist., New Taipei City 235
Taiwan (R.O.C)

Tel: +886-(2) 8226-3990

Fax: +886-(2) 8226-3992

Email: support@supermicro.com.tw

Website: www.supermicro.com.tw

Notes

Chapter 2

Installation

2-1 Overview

This chapter provides a quick setup checklist to get your SuperWorkstation 5038A-I up and running. Following these steps in the order given should enable you to have the system operational within a minimum amount of time.

If your system is not already fully integrated with a motherboard, processor, system memory etc., please turn to the chapter or section noted in each step for details on installing specific components. Please read the Server Precautions in the next section before using the system for the first time.

2-2 Unpacking the System

You should inspect the box the system was shipped in and note if it was damaged in any way. If the system itself shows damage you should file a damage claim with the carrier who delivered it.

Decide on a suitable location for the SuperWorkstation. It should be situated in a clean, dust-free area that is well ventilated. Avoid areas where heat, electrical noise and electromagnetic fields are generated. You will also need it placed near a grounded power outlet.

Notes

Chapter 3

System Interface

3-1 Overview

The control panel on the 5038A-I has several LEDs and a power button. These LEDs keep you constantly informed of the overall status of the system and the activity and health of specific components.

3-2 Control Panel Buttons

There is single power on/off push-button located on the front of the chassis.

Power



This is the main power button, which is used to apply or turn off the main system power. Turning off system power with this button removes the main power but keeps standby power supplied to the system.

3-3 Control Panel LEDs

The control panel located on the front of the SC732D3-903B chassis has three LEDs that provide you with critical information related to different parts of the system. This section explains what each LED indicates when illuminated and any corrective action you may need to take.



NIC

Indicates network activity on GLAN when flashing.



HDD

Indicates IDE channel activity on the SATA drive and/or DVD-ROM drive when flashing.



Information LED

Alerts operator of several states, as noted in the table below.

Information LED	
Status	Description
Continuously on and red	An overheat condition has occurred. (This may be caused by cable congestion.)
Blinking red (1Hz)	Fan failure, check for an inoperative fan.
Blinking red (0.25Hz)	Power failure, check for a non-operational power supply.
Solid blue	Local UID has been activated. Use this function to locate the server in a rack mount environment.
Blinking blue	Remote UID is on. Use this function to identify the server from a remote location.

Chapter 4

Standardized Warning Statements for AC Systems

4-1 About Standardized Warning Statements

The following statements are industry standard warnings, provided to warn the user of situations which have the potential for bodily injury. Should you have questions or experience difficulty, contact Supermicro's Technical Support department for assistance. Only certified technicians should attempt to install or configure components.

Read this appendix in its entirety before installing or configuring components in the Supermicro chassis.

These warnings may also be found on our web site at http://www.supermicro.com/about/policies/safety_information.cfm.

Warning Definition



Warning!

This warning symbol means danger. You are in a situation that could cause bodily injury. Before you work on any equipment, be aware of the hazards involved with electrical circuitry and be familiar with standard practices for preventing accidents.

警告の定義

この警告サインは危険を意味します。

人身事故につながる可能性がありますので、いずれの機器でも動作させる前に、電気回路に含まれる危険性に注意して、標準的な事故防止策に精通して下さい。

此警告符号代表危險。

您正处于可能受到严重伤害的工作环境中。在您使用设备开始工作之前，必须充分意识到触电的危险，并熟练掌握防止事故发生的标准工作程序。请根据每项警告结尾的声明号码找到此设备的安全性警告说明的翻译文本。

此警告符號代表危險。

您正處於可能身體可能會受損傷的工作環境中。在您使用任何設備之前，請注意觸電的危險，並且要熟悉預防事故發生的標準工作程序。請依照每一注意事項後的號碼找到相關的翻譯說明內容。

Warnung

WICHTIGE SICHERHEITSHINWEISE

Dieses Warnsymbol bedeutet Gefahr. Sie befinden sich in einer Situation, die zu Verletzungen führen kann. Machen Sie sich vor der Arbeit mit Geräten mit den Gefahren elektrischer Schaltungen und den üblichen Verfahren zur Vorbeugung vor Unfällen vertraut. Suchen Sie mit der am Ende jeder Warnung angegebenen Anweisungsnummer nach der jeweiligen Übersetzung in den übersetzten Sicherheitshinweisen, die zusammen mit diesem Gerät ausgeliefert wurden.

BEWAHREN SIE DIESE HINWEISE GUT AUF.

INSTRUCCIONES IMPORTANTES DE SEGURIDAD

Este símbolo de aviso indica peligro. Existe riesgo para su integridad física. Antes de manipular cualquier equipo, considere los riesgos de la corriente eléctrica y familiarícese con los procedimientos estándar de prevención de accidentes. Al final de cada advertencia encontrará el número que le ayudará a encontrar el texto traducido en el apartado de traducciones que acompaña a este dispositivo.

GUARDE ESTAS INSTRUCCIONES.

IMPORTANTES INFORMATIONS DE SÉCURITÉ

Ce symbole d'avertissement indique un danger. Vous vous trouvez dans une situation pouvant entraîner des blessures ou des dommages corporels. Avant de travailler sur un équipement, soyez conscient des dangers liés aux circuits électriques et familiarisez-vous avec les procédures couramment utilisées pour éviter les accidents. Pour prendre connaissance des traductions des avertissements figurant dans les consignes de sécurité traduites qui accompagnent cet appareil, référez-vous au numéro de l'instruction situé à la fin de chaque avertissement.

CONSERVEZ CES INFORMATIONS.

תקנת הצהרות אזהרה

הצהרות הבאות הן אזהרות על פי תקני התעשייה, על מנת להזהיר את המשתמש מפני חבלה פיזית אפשרית. במידה ויש שאלות או היתקלות בבעיה כלשהי, יש ליצור קשר עם מחלקת תמיכה טכנית של סופרמיקרו. טכנאים מוסמכים בלבד רשאים להתקין או להגדיר את הרכיבים.

יש לקרוא את הנספח במלוואו לפני התקנת או הגדרת הרכיבים במארוזי סופרמיקרו.

تحذير! هذا الرمز يعني خطر انك في حالة يمكن أن تتسبب في اصابة جسدية .
قبل أن تعمل على أي معدات، كن على علم بالمخاطر الناجمة عن الدوائر
الكهربائية
وكن على دراية بالممارسات الوقائية لمنع وقوع أي حوادث
استخدم رقم البيان المنصوص في نهاية كل تحذير للعثور ترجمتها

안전을 위한 주의사항

경고!

이 경고 기호는 위험이 있음을 알려 줍니다. 작업자의 신체에 부상을 야기 할 수 있는 상태에 있게 됩니다. 모든 장비에 대한 작업을 수행하기 전에 전기회로와 관련된 위험요소들을 확인하시고 사전에 사고를 방지할 수 있도록 표준 작업질차를 준수해 주시기 바랍니다.

해당 번역문을 찾기 위해 각 경고의 마지막 부분에 제공된 경고문 번호를 참조하십시오

BELANGRIJKE VEILIGHEIDSINSTRUCTIES

Dit waarschuwings symbool betekent gevaar. U verkeert in een situatie die lichamelijk letsel kan veroorzaken. Voordat u aan enige apparatuur gaat werken, dient u zich bewust te zijn van de bij een elektrische installatie betrokken risico's en dient u op de hoogte te zijn van de standaard procedures om ongelukken te voorkomen. Gebruik de nummers aan het eind van elke waarschuwing om deze te herleiden naar de desbetreffende locatie.

BEWAAR DEZE INSTRUCTIES

Installation Instructions



Warning!

Read the installation instructions before connecting the system to the power source.

設置手順書

システムを電源に接続する前に、設置手順書をお読み下さい。

警告

将此系统连接电源前，请先阅读安装说明。

警告

將系統與電源連接前，請先閱讀安裝說明。

Warnung

Vor dem Anschließen des Systems an die Stromquelle die Installationsanweisungen lesen.

¡Advertencia!

Lea las instrucciones de instalación antes de conectar el sistema a la red de alimentación.

Attention

Avant de brancher le système sur la source d'alimentation, consulter les directives d'installation.

יש לקרוא את הוראות התקנה לפני חיבור המערכת למקור מתח.

اقرأ إرشادات التركيب قبل توصيل النظام إلى مصدر للطاقة

시스템을 전원에 연결하기 전에 설치 안내를 읽어주시시오.

Waarschuwing

Raadpleeg de installatie-instructies voordat u het systeem op de voedingsbron aansluit.

Circuit Breaker



Warning!

This product relies on the building's installation for short-circuit (overcurrent) protection. Ensure that the protective device is rated not greater than: 250 V, 20 A.

サーキット・ブレーカー

この製品は、短絡(過電流)保護装置がある建物での設置を前提としています。

保護装置の定格が250 V、20 Aを超えないことを確認下さい。

警告

此产品的短路(过载电流)保护由建筑物的供电系统提供,确保短路保护设备的额定电流不大于250V,20A。

警告

此产品的短路(过载电流)保护由建筑物的供电系统提供,确保短路保护设备的额定电流不大于250V,20A。

Warnung

Dieses Produkt ist darauf angewiesen, dass im Gebäude ein Kurzschluss- bzw. Überstromschutz installiert ist. Stellen Sie sicher, dass der Nennwert der Schutzvorrichtung nicht mehr als: 250 V, 20 A beträgt.

¡Advertencia!

Este equipo utiliza el sistema de protección contra cortocircuitos (o sobrecorrientes) del edificio. Asegúrese de que el dispositivo de protección no sea superior a: 250 V, 20 A.

Attention

Pour ce qui est de la protection contre les courts-circuits (surtension), ce produit dépend de l'installation électrique du local. Vérifiez que le courant nominal du dispositif de protection n'est pas supérieur à :250 V, 20 A.

מוצר זה מסתמך על הגנה המותקנת במבנים למניעת קצר חשמלי. יש לוודא
המכשיר המגן מפני הקצר החשמלי הוא לא יותר מ-60VDC, 20A

هذا المنتج يعتمد على معدات الحماية من الدوائر القصيرة التي تم تثبيتها في
المبنى

تأكد من أن تقييم الجهاز الوقائي ليس أكثر من: 20A, 250VDC

경고!

이 제품은 전원의 단락(과전류)방지에 대해서 전적으로 건물의 관련 설비에 의존합니다. 보호장치의 정격이 반드시 250V(볼트), 20A(암페어)를 초과하지 않도록 해야 합니다.

Waarschuwing

Dit product is afhankelijk van de kortsluitbeveiliging (overspanning) van uw elektrische installatie. Controleer of het beveiligde apparaat niet groter gedimensioneerd is dan 220V, 20A.

Power Disconnection Warning



Warning!

The system must be disconnected from all sources of power and the power cord removed from the power supply module(s) before accessing the chassis interior to install or remove system components.

電源切斷の警告

システムコンポーネントの取り付けまたは取り外しのために、シャーシ内部にアクセスするには、

システムの電源はすべてのソースから切斷され、電源コードは電源モジュールから取り外す必要があります。

警告

在你打开机箱并安装或移除内部器件前，必须将系统完全断电，并移除电源线。

警告

在您打開機殼安裝或移除內部元件前，必須將系統完全斷電，並移除電源線。

Warnung

Das System muss von allen Quellen der Energie und vom Netzanschlusskabel getrennt sein, das von den Spg.Versorgungsteilmodulen entfernt wird, bevor es auf den Chassisinnenraum zurückgreift, um Systemsbestandteile anzubringen oder zu entfernen.

¡Advertencia!

El sistema debe ser disconnected de todas las fuentes de energía y del cable eléctrico quitado de los módulos de fuente de alimentación antes de tener acceso el interior del chasis para instalar o para quitar componentes de sistema.

Attention

Le système doit être débranché de toutes les sources de puissance ainsi que de son cordon d'alimentation secteur avant d'accéder à l'intérieur du châssis pour installer ou enlever des composants de système.

אזהרה !

יש לנתק את המערכת מכל מקורות החשמל ויש להסיר את כבל החשמלי מהספק לפני גישה לחלק הפנימי של המארז לצורך התקנת או הסרת רכיבים.

يجب فصل النظام من جميع مصادر الطاقة وإزالة سلك الكهرباء من وحدة امداد الطاقة قبل الوصول إلى المناطق الداخلية للهيكल لتثبيت أو إزالة مكونات الجهاز

경고!

시스템에 부품들을 장착하거나 제거하기 위해서는 새시 내부에 접근하기 전에 반드시 전원 공급장치로부터 연결되어있는 모든 전원과 전기코드를 분리해주어야 합니다.

Waarschuwing

Voordat u toegang neemt tot het binnenwerk van de behuizing voor het installeren of verwijderen van systeem onderdelen, dient u alle spanningsbronnen en alle stroomkabels aangesloten op de voeding(en) van de behuizing te verwijderen

Equipment Installation



Warning!

Only trained and qualified personnel should be allowed to install, replace, or service this equipment.

機器の設置

トレーニングを受け認定された人だけがこの装置の設置、交換、またはサービスを許可されています。

警告

只有经过培训且具有资格的人员才能进行此设备的安装、更换和维修。

警告

只有經過受訓且具資格人員才可安裝、更換與維修此設備。

Warnung

Das Installieren, Ersetzen oder Bedienen dieser Ausrüstung sollte nur geschultem, qualifiziertem Personal gestattet werden.

¡Advertencia!

Solamente el personal calificado debe instalar, reemplazar o utilizar este equipo.

Attention

Il est vivement recommandé de confier l'installation, le remplacement et la maintenance de ces équipements à des personnels qualifiés et expérimentés.

אזהרה!

צוות מוסמך בלבד רשאי להתקין, להחליף את הציוד או לתת שירות עבור הציוד.

يجب أن يسمح فقط للموظفين المؤهلين والمدربين لتثبيت واستبدال أو خدمة هذا الجهاز

경고!

훈련을 받고 공인된 기술자만이 이 장비의 설치, 교체 또는 서비스를 수행할 수 있습니다.

Waarschuwing

Deze apparatuur mag alleen worden geïnstalleerd, vervangen of hersteld door geschoold en gekwalificeerd personeel.

Restricted Area



Warning!

This unit is intended for installation in restricted access areas. A restricted access area can be accessed only through the use of a special tool, lock and key, or other means of security. (This warning does not apply to workstations).

アクセス制限区域

このユニットは、アクセス制限区域に設置されることを想定しています。

アクセス制限区域は、特別なツール、鍵と錠前、その他のセキュリティの手段を用いてのみ出入りが可能です。

警告

此部件应安装在限制进出的场所，限制进出的场所指只能通过使用特殊工具、锁和钥匙或其它安全手段进出的场所。

警告

此裝置僅限安裝於進出管制區域，進出管制區域係指僅能以特殊工具、鎖頭及鑰匙或其他安全方式才能進入的區域。

Warnung

Diese Einheit ist zur Installation in Bereichen mit beschränktem Zutritt vorgesehen. Der Zutritt zu derartigen Bereichen ist nur mit einem Spezialwerkzeug, Schloss und Schlüssel oder einer sonstigen Sicherheitsvorkehrung möglich.

¡Advertencia!

Esta unidad ha sido diseñada para instalación en áreas de acceso restringido. Sólo puede obtenerse acceso a una de estas áreas mediante la utilización de una herramienta especial, cerradura con llave u otro medio de seguridad.

Attention

Cet appareil doit être installée dans des zones d'accès réservés. L'accès à une zone d'accès réservé n'est possible qu'en utilisant un outil spécial, un mécanisme de verrouillage et une clé, ou tout autre moyen de sécurité.

אזור עם גישה מוגבלת

אזהרה!

יש להתקין את היחידה באזורים שיש בהם הגבלת גישה. הגישה ניתנת בעזרת כלי אבטחה בלבד (מפתח, מנעול וכד').

تم تخصيص هذه الوحدة لت تركيبها في مناطق محظورة .
يمكن الوصول إلى منطقة محظورة فقط من خلال استخدام أداة خاصة،
قفل ومفتاح أو أي وسيلة أخرى للالأمين

경고!

이 장치는 접근이 제한된 구역에 설치하도록 되어 있습니다. 특수도구, 잠금 장치 및 키, 또는 기타 보안 수단을 통해서만 접근 제한 구역에 들어갈 수 있습니다.

Waarschuwing

Dit apparaat is bedoeld voor installatie in gebieden met een beperkte toegang. Toegang tot dergelijke gebieden kunnen alleen verkregen worden door gebruik te maken van speciaal gereedschap, slot en sleutel of andere veiligheidsmaatregelen.

Battery Handling



Warning!

There is the danger of explosion if the battery is replaced incorrectly. Replace the battery only with the same or equivalent type recommended by the manufacturer. Dispose of used batteries according to the manufacturer's instructions

電池の取り扱い

電池交換が正しく行われなかった場合、破裂の危険性があります。交換する電池はメーカーが推奨する型、または同等のものを使用下さい。使用済電池は製造元の指示に従って処分して下さい。

警告

電池更換不當會有爆炸危險。請只使用同類電池或製造商推薦的功能相當的電池更換原有電池。請按製造商的說明處理廢舊電池。

警告

電池更換不當會有爆炸危險。請使用製造商建議之相同或功能相當的電池更換原有電池。請按照製造商的說明指示處理廢棄舊電池。

Warnung

Bei Einsetzen einer falschen Batterie besteht Explosionsgefahr. Ersetzen Sie die Batterie nur durch den gleichen oder vom Hersteller empfohlenen Batterietyp. Entsorgen Sie die benutzten Batterien nach den Anweisungen des Herstellers.

Attention

Danger d'explosion si la pile n'est pas remplacée correctement. Ne la remplacer que par une pile de type semblable ou équivalent, recommandée par le fabricant. Jeter les piles usagées conformément aux instructions du fabricant.

¡Advertencia!

Existe peligro de explosión si la batería se reemplaza de manera incorrecta. Reemplazar la batería exclusivamente con el mismo tipo o el equivalente recomendado por el fabricante. Desechar las baterías gastadas según las instrucciones del fabricante.

אזהרה!

קיימת סכנת פיצוץ של הסוללה במידה והוחלפה בדרך לא תקינה. יש להחליף את הסוללה בסוג התואם מחברת יצרן מומלצת.

סילוק הסוללות המשומשות יש לבצע לפי הוראות היצרן.

هناك خطر من انفجار في حالة استبدال البطارية بطريقة غير صحيحة فعليك استبدال البطارية فقط بنفس النوع أو ما يعادلها كما أوصت به الشركة المصنعة تخلص من البطاريات المستعملة وفقا لتعليمات الشركة الصانعة

경고!

배터리가 올바르게 교체되지 않으면 폭발의 위험이 있습니다. 기존 배터리와 동일하거나 제조사에서 권장하는 동등한 종류의 배터리로만 교체해야 합니다. 제조사의 안내에 따라 사용된 배터리를 처리하여 주십시오.

Waarschuwing

Er is ontploffingsgevaar indien de batterij verkeerd vervangen wordt. Vervang de batterij slechts met hetzelfde of een equivalent type die door de fabrikant aanbevolen wordt. Gebruikte batterijen dienen overeenkomstig fabrieksvoorschriften afgevoerd te worden.

Redundant Power Supplies



Warning!

This unit might have more than one power supply connection. All connections must be removed to de-energize the unit.

冗長電源装置

このユニットは複数の電源装置が接続されている場合があります。
ユニットの電源を切るためには、すべての接続を取り外さなければなりません。

警告

此部件连接的电源可能不止一个，必须将所有电源断开才能停止给该部件供电。

警告

此装置连接的电源可能不只一个，必须切断所有电源才能停止对该装置的供电。

Warnung

Dieses Gerät kann mehr als eine Stromzufuhr haben. Um sicherzustellen, dass der Einheit kein Strom zugeführt wird, müssen alle Verbindungen entfernt werden.

¡Advertencia!

Puede que esta unidad tenga más de una conexión para fuentes de alimentación. Para cortar por completo el suministro de energía, deben desconectarse todas las conexiones.

Attention

Cette unité peut avoir plus d'une connexion d'alimentation. Pour supprimer toute tension et tout courant électrique de l'unité, toutes les connexions d'alimentation doivent être débranchées.

אם קיים יותר מספק אחד

אזהרה!

ליחידה יש יותר מחיבור אחד של ספק. יש להסיר את כל החיבורים על מנת לרוקן את היחידה.

قد يكون لهذا الجهاز عدة اتصالات بوحدات امداد الطاقة.
يجب إزالة كافة الاتصالات لعزل الوحدة عن الكهرباء

경고!

이 장치에는 한 개 이상의 전원 공급 단자가 연결되어 있을 수 있습니다. 이 장치에 전원을 차단하기 위해서는 모든 연결 단자를 제거해야만 합니다.

Waarschuwing

Deze eenheid kan meer dan één stroomtoevoeraansluiting bevatten. Alle aansluitingen dienen verwijderd te worden om het apparaat stroomloos te maken.

Backplane Voltage



Warning!

Hazardous voltage or energy is present on the backplane when the system is operating. Use caution when servicing.

バックプレーンの電圧

システムの稼働中は危険な電圧または電力が、バックプレーン上にかかっています。

修理する際にはご注意ください。

警告

当系統正在进行时，背板上有很危险的电压或能量，进行维修时务必小心。

警告

當系統正在進行時，背板上有很危險的電壓或能量，進行維修時務必小心。

Warnung

Wenn das System in Betrieb ist, treten auf der Rückwandplatine gefährliche Spannungen oder Energien auf. Vorsicht bei der Wartung.

¡Advertencia!

Cuando el sistema está en funcionamiento, el voltaje del plano trasero es peligroso. Tenga cuidado cuando lo revise.

Attention

Lorsque le système est en fonctionnement, des tensions électriques circulent sur le fond de panier. Prendre des précautions lors de la maintenance.

מתח בפנל האחורי

אזהרה!
קיימת סכנת מתח בפנל האחורי בזמן תפעול המערכת. יש להיזהר במהלך
העבודה.

هناك خطر من التيار الكهربائي أو الطاقة الموجودة على اللوحة
عندما يكون النظام يعمل كن حذرا عند خدمة هذا الجهاز

경고!

시스템이 동작 중일 때 후면판 (Backplane)에는 위험한 전압이나 에너지가 발생
합니다. 서비스 작업 시 주의하십시오.

Waarschuwing

Een gevaarlijke spanning of energie is aanwezig op de backplane wanneer het
systeem in gebruik is. Voorzichtigheid is geboden tijdens het onderhoud.

Comply with Local and National Electrical Codes



Warning!

Installation of the equipment must comply with local and national electrical codes.

地方および国の電気規格に準拠

機器の取り付けはその地方および国の電気規格に準拠する必要があります。

警告

设备安装必须符合本地与本国电气法规。

警告

設備安裝必須符合本地與本國電氣法規。

Warnung

Die Installation der Geräte muss den Sicherheitsstandards entsprechen.

¡Advertencia!

La instalación del equipo debe cumplir con las normas de electricidad locales y
nacionales.

Attention

L'équipement doit être installé conformément aux normes électriques nationales et locales.

תיאום חוקי החשמל הארצי

אזהרה!

התקנת הציוד חייבת להיות תואמת לחוקי החשמל המקומיים והארציים.

تركيب المعدات الكهربائية يجب أن يمتثل للقوانين المحلية والوطنية المتعلقة بالكهرباء

경고!

현 지역 및 국가의 전기 규정에 따라 장비를 설치해야 합니다.

Waarschuwing

Bij installatie van de apparatuur moet worden voldaan aan de lokale en nationale elektriciteitsvoorschriften.

Product Disposal



Warning!

Ultimate disposal of this product should be handled according to all national laws and regulations.

製品の廃棄

この製品を廃棄処分する場合、国の関係する全ての法律・条例に従い処理する必要があります。

警告

本产品的废弃处理应根据所有国家的法律和规章进行。

警告

本產品的廢棄處理應根據所有國家的法律和規章進行。

Warnung

Die Entsorgung dieses Produkts sollte gemäß allen Bestimmungen und Gesetzen des Landes erfolgen.

¡Advertencia!

Al deshacerse por completo de este producto debe seguir todas las leyes y reglamentos nacionales.

Attention

La mise au rebut ou le recyclage de ce produit sont généralement soumis à des lois et/ou directives de respect de l'environnement. Renseignez-vous auprès de l'organisme compétent.

סילוק המוצר

אזהרה!

סילוק סופי של מוצר זה חייב להיות בהתאם להנחיות וחוקי המדינה.

عند التخلص النهائي من هذا المنتج ينبغي التعامل معه وفقا لجميع القوانين واللوائح الوطنية

경고!

이 제품은 해당 국가의 관련 법규 및 규정에 따라 폐기되어야 합니다.

Waarschuwing

De uiteindelijke verwijdering van dit product dient te geschieden in overeenstemming met alle nationale wetten en reglementen.

Hot Swap Fan Warning



Warning!

The fans might still be turning when you remove the fan assembly from the chassis. Keep fingers, screwdrivers, and other objects away from the openings in the fan assembly's housing.

ファン・ホットスワップの警告

シャーシから冷却ファン装置を取り外した際、ファンがまだ回転している可能性があります。ファンの開口部に、指、ドライバー、およびその他のものを近づけないで下さい。

警告

当您从机架移除风扇装置，风扇可能仍在转动。小心不要将手指、螺丝起子和其他物品太靠近风扇

警告

當您從機架移除風扇裝置，風扇可能仍在轉動。小心不要將手指、螺絲起子和其他物品太靠近風扇。

Warnung

Die Lüfter drehen sich u. U. noch, wenn die Lüfterbaugruppe aus dem Chassis genommen wird. Halten Sie Finger, Schraubendreher und andere Gegenstände von den Öffnungen des Lüftergehäuses entfernt.

¡Advertencia!

Los ventiladores podran dar vuelta cuando usted quite el montaje del ventilador del chasis. Mantenga los dedos, los destornilladores y todos los objetos lejos de las aberturas del ventilador

Attention

Il est possible que les ventilateurs soient toujours en rotation lorsque vous retirez le bloc ventilateur du châssis. Prenez garde à ce que doigts, tournevis et autres objets soient éloignés du logement du bloc ventilateur.

אזהרה!

כאשר מסירים את חלקי המאוורר מהמארז, יתכן והמאווררים עדיין עובדים. יש להרחיק למרחק בטוח את האצבעות וכלי עבודה שונים מהפתחים בתוך המאוורר

من الممكن أن المراوح لا تزال تدور عند إزالة كتلة المروحة من الهيكل يجب إبقاء الأصابع ومفكات البراغي وغيرها من الأشياء بعيدا عن الفتحات في كتلة المروحة.

경고!

새시로부터 팬 조립품을 제거할 때 팬은 여전히 회전하고 있을 수 있습니다. 팬 조립품 외관의 열려있는 부분들로부터 손가락 및 스크류드라이버, 다른 물체들이 가까이 하지 않도록 배치해 주십시오.

Waarschuwing

Het is mogelijk dat de ventilator nog draait tijdens het verwijderen van het ventilatorsamenstel uit het chassis. Houd uw vingers, schroevendraaiers en eventuele andere voorwerpen uit de buurt van de openingen in de ventilatorbehuizing.

Power Cable and AC Adapter



Warning!

When installing the product, use the provided or designated connection cables, power cables and AC adaptors. Using any other cables and adaptors could cause a malfunction or a fire. Electrical Appliance and Material Safety Law prohibits the use of UL or CSA -certified cables (that have UL/CSA shown on the code) for any other electrical devices than products designated by Supermicro only.

電源コードとACアダプター

製品を設置する場合、提供または指定された接続ケーブル、電源コードとACアダプターを使用下さい。他のケーブルやアダプタを使用すると故障や火災の原因になることがあります。電気用品安全法は、ULまたはCSA認定のケーブル(UL/CSEマークがコードに表記)をSupermicroが指定する製品以外に使用することを禁止しています。

警告

安装此产品时,请使用本身提供的或指定的连接线,电源线和电源适配器.使用其它线材或适配器可能会引起故障或火灾.除了Supermicro所指定的产品,电气用品和材料安全法律规定禁止使用未经UL或CSA认证的线材。(线材上会显示UL/CSA符号)。

警告

安装此產品時,請使用本身提供的或指定的連接線,電源線和電源適配器.使用其它線材或適配器可能會引起故障或火災.除了Supermicro所指定的產品,電氣用品和材料安全法律規定禁止使用未經UL或CSA認證的線材。(線材上會顯示UL/CSA符號)。

Warnung

Bei der Installation des Produkts, die zur Verfügung gestellten oder benannt Anschlusskabel, Stromkabel und Netzteile. Verwendung anderer Kabel und Adapter kann zu einer Fehlfunktion oder ein Brand entstehen. Elektrische Geräte und Material Safety Law verbietet die Verwendung von UL-oder CSA-zertifizierte Kabel, UL oder CSA auf der Code für alle anderen elektrischen Geräte als Produkte von Supermicro nur bezeichnet gezeigt haben.

¡Advertencia!

Al instalar el producto, utilice los cables de conexión previstos o designados, los cables y adaptadores de CA. La utilización de otros cables y adaptadores podría ocasionar un mal funcionamiento o un incendio. Aparatos Eléctricos y la Ley de Seguridad del Material prohíbe el uso de UL o CSA cables certificados que tienen UL o CSA se muestra en el código de otros dispositivos eléctricos que los productos designados por Supermicro solamente.

Attention

Lors de l'installation du produit, utilisez les bables de connection fournis ou désigné. L'utilisation d'autres cables et adaptateurs peut provoquer un dysfonctionnement ou un incendie. Appareils électroménagers et de loi sur la sécurité Matériel interdit l'utilisation de UL ou CSA cables certifiés qui ont UL ou CSA indiqué sur le code pour tous les autres appareils électriques que les produits désignés par Supermicro seulement.

חשמליים ומתאמי AC

אזהרה!

כאשר מתקינים את המוצר, יש להשתמש בכבלים, ספקים ומתאמים AC אשר נועדו וסופקו לשם כך. שימוש בכל כבל או מתאם אחר יכול לגרום לתקלה או קצר חשמלי. על פי חוקי שימוש במכשירי חשמל וחוקי בטיחות, קיים איסור להשתמש בכבלים המוסמכים ב- UL או ב- CSA (כשאר מופיע עליהם קוד של UL/CSA) עבור כל מוצר חשמלי אחר שלא צויין על ידי סופרמיקרו בלבד.

عند تركيب الجهاز يجب استخدام كابلات التوصيل، والكابلات الكهربائية ومحولات التيار المتردد التي . أن استخدام أي كابلات ومحولات أخرى يتسبب في حدوث عطل أو حريق. تم توفيرها لك مع المنتج الأجهزة الكهربائية ومواد قانون السلامة يحظر استخدام الكابلات CSA أو UL معتمدة من قبل لأي أجهزة كهربائية أخرى غير المنتجات المعينة من قبل Supermicro (التي تحمل علامة UL/CSA)

경고!

제품을 설치할 때에는 제공되거나 지정된 연결케이블과 전원케이블, AC 어댑터를 사용해야 합니다. 그 밖의 다른 케이블들이나 어댑터들은 고장 또는 화재의 원인이 될 수 있습니다. 전기용품안전법 (Electrical Appliance and Material Safety Law)은 슈퍼마이크로에서 지정한 제품들 외에는 그 밖의 다른 전기 장치들을 위한 UL 또는 CSA에서 인증한 케이블(전선 위에 UL/CSA가 표시)들의 사용을 금지합니다.

Waarschuwing

Bij het installeren van het product, gebruik de meegeleverde of aangewezen kabels, stroomkabels en adapters. Het gebruik van andere kabels en adapters kan leiden tot een storing of een brand. Elektrisch apparaat en veiligheidsinformatiebladen wet verbiedt het gebruik van UL of CSA gecertificeerde kabels die UL of CSA die op de code voor andere elektrische apparaten dan de producten die door Supermicro alleen.

Notes

Chapter 5

Advanced Motherboard Setup

This chapter covers the data and power cables and add-on cards. All motherboard jumpers and connections are also described. A layout and quick reference chart are included in this chapter for your reference. Remember to completely close the chassis when you have finished working with the motherboard to better cool and protect the system.

5-1 Handling the Motherboard

Electrostatic discharge (ESD) can damage electronic components. To prevent damage to any printed circuit boards (PCBs), it is important to handle them very carefully (see previous chapter). To prevent the motherboard from bending, keep one hand under the center of the board to support it when handling. The following measures are generally sufficient to protect your equipment from electric static discharge.

Cautions

- Use a grounded wrist strap designed to prevent electrostatic discharge.
- Touch a grounded metal object before removing any board from its antistatic bag.
- Handle a board by its edges only; do not touch its components, peripheral chips, memory modules or gold contacts.
- When handling chips or modules, avoid touching their pins.
- Put the motherboard, add-on cards and peripherals back into their antistatic bags when not in use.
- For grounding purposes, make sure your computer chassis provides excellent conductivity between the power supply, the case, the mounting fasteners and the motherboard.

5-2 Connecting Cables

Now that the motherboard is installed, the next step is to connect the cables to the board. These include the data (ribbon) cables for the peripherals and control panel and the power cables.

Connecting Data Cables

The cables used to transfer data from the peripheral devices have been carefully routed to prevent them from blocking the flow of cooling air that moves through the system from front to back. If you need to disconnect any of these cables, you should keep them routed as they were originally after reconnecting them (make sure the red wires connect to the pin 1 locations). See the layout on page 5-9 for connector locations.

Caution: Make sure that the cables do not come into contact with the fans.

Connecting Power Cables

The X10SRA has a 24-pin primary power supply connector (JPW1) for connection to the ATX power supply. In addition, the 8-pin secondary power connector (JPW2) must also be connected to your power supply. See Section 5-9 for power connector pin definitions.

Connecting the Control Panel

JF1 contains header pins for various front control panel connectors. See Figure 5-1 for the pin locations of the various front control panel buttons and LED indicators.

All JF1 wires have been bundled into a single ribbon cable to simplify this connection. Make sure the red wire plugs into pin 1 as marked on the board. The other end connects to the Control Panel PCB board, located just behind the system status LEDs on the chassis. See Chapter 5 for details and pin descriptions.

Figure 5-1. Control Panel Header Pins

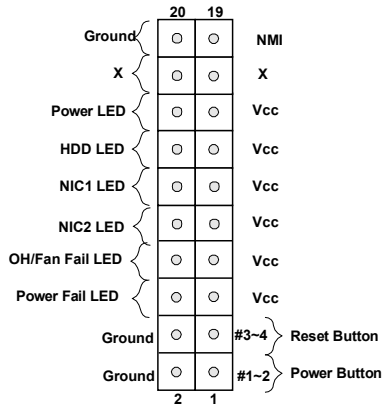

5-3 Rear I/O Ports

See Figure 5-2 below for the locations and descriptions of the various I/O ports.

Figure 5-2. Rear I/O Ports

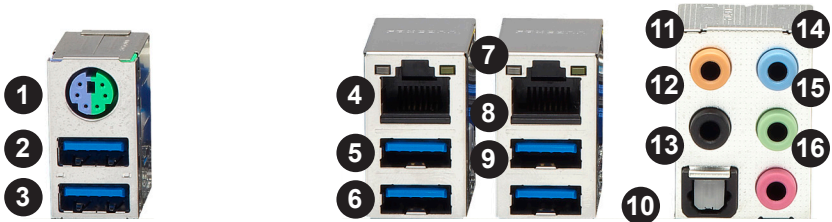

Rear I/O Ports	
1. PS/2 Keyboard/Mouse Port	9. USB13 Port (USB 3.0)
2. USB14 Port (USB 3.0)	10. Clear CMOS Button
3. USB15 Port (USB 3.0)	11. Center/LFE Out
4. Gb LAN1 Port	12. Surround Out
5. USB10 Port (USB 3.0)	13. S/PDIF Out
6. USB11 Port (USB 3.0)	14. Line In
7. Gb LAN2 Port	15. Line Out
8. USB12 Port (USB 3.0)	16. Mic In

5-4 Processor and Heatsink Installation

Caution: When handling the processor package, avoid placing direct pressure on the label area of the fan.

Notes:

- Always connect the power cord last and always remove it before adding, removing or changing any hardware components. Make sure that you install the processor into the CPU socket before you install the CPU heatsink.
- If you buy a CPU separately, make sure that you use an Intel-certified multi-directional heatsink only.
- Make sure to install the motherboard into the chassis before you install the CPU heatsinks.
- When receiving a motherboard without a processor pre-installed, make sure that the plastic CPU socket cap is in place and none of the socket pins are bent; otherwise, contact your retailer immediately.
- Refer to the Supermicro website for updates on CPU support.

Installing an LGA 2011 Processor

1. There are two levers on the LGA2011 socket. First press and release the load lever labeled 'Open 1st'.
2. Press the second load lever labeled 'Close 1st' to release the load plate from its locked position.

Press down on the lever labeled
'Close 1st'

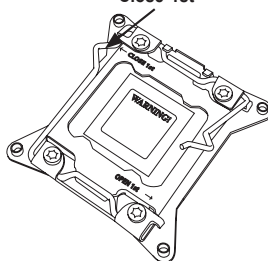

Pull lever away
from the socket

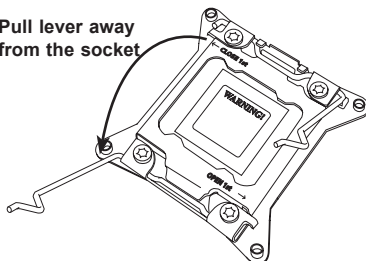

3. With the lever labeled 'Close 1st' fully retracted, gently push down on the 'Open 1st' lever to open the load plate. Lift the load plate to open it completely.
4. Using your thumb and the index finger, remove the 'WARNING' plastic cap from the socket.

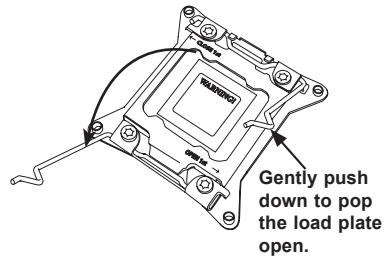

5. Use your thumb and index finger to hold the CPU by its edges. Align the CPU keys, which are semi-circle cutouts, against the socket keys.

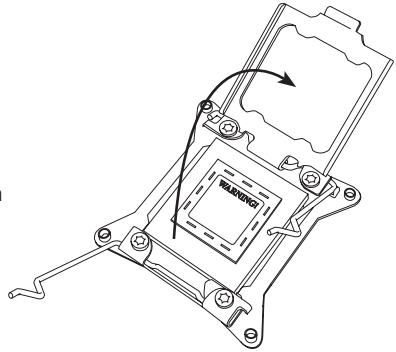

6. Once they are aligned, carefully lower the CPU straight down into the socket. (Do not drop the CPU on the socket. Do not move the CPU horizontally or vertically and do not rub the CPU against any pins of the socket, which may damage the CPU or the socket.)

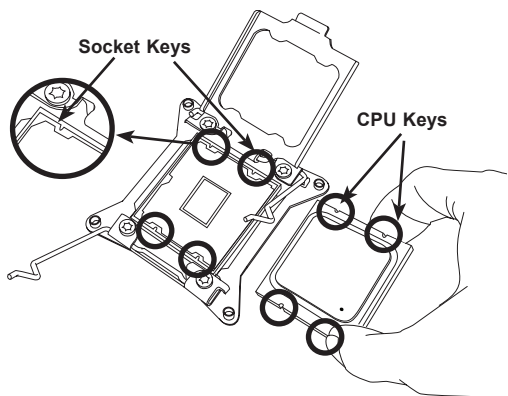

Caution: You can only install the CPU to the socket in one direction. Make sure that the CPU is properly inserted into the socket before closing the load plate. If it doesn't close properly, do not force it as it may damage your CPU. Instead, open the load plate again and double-check that the CPU is aligned properly.

7. With the CPU in the socket, inspect the four corners of the CPU to make sure that they are flush with the socket.

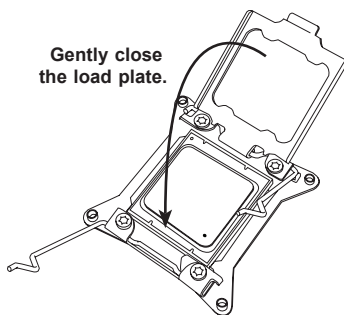

8. Close the load plate. Lock the lever labeled 'Close 1st', then lock the lever labeled 'Open 1st'. Use your thumb to gently push the load levers down until the lever locks.

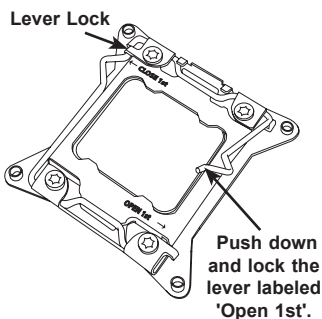
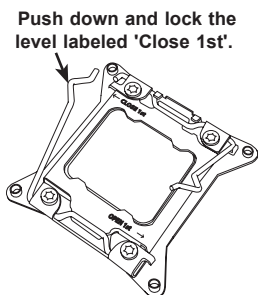

Installing a CPU Heatsink

Caution: Remove the power cord before installing heatsinks. Do not reconnect it until the installation is completed. See http://www.supermicro.com/about/policies/safety_information.cfm.

1. Do not apply any thermal grease to the heatsink or the CPU die; the required amount has already been applied.
2. Place the heatsink on top of the CPU so that the four mounting holes are aligned with those on the motherboard and the heatsink bracket underneath.
3. Screw in two diagonal screws (i.e., the #1 and the #2 screws) until just snug. (To avoid possible damage to the CPU do not over-tighten the screws.)
4. Finish the installation by fully tightening all four screws.

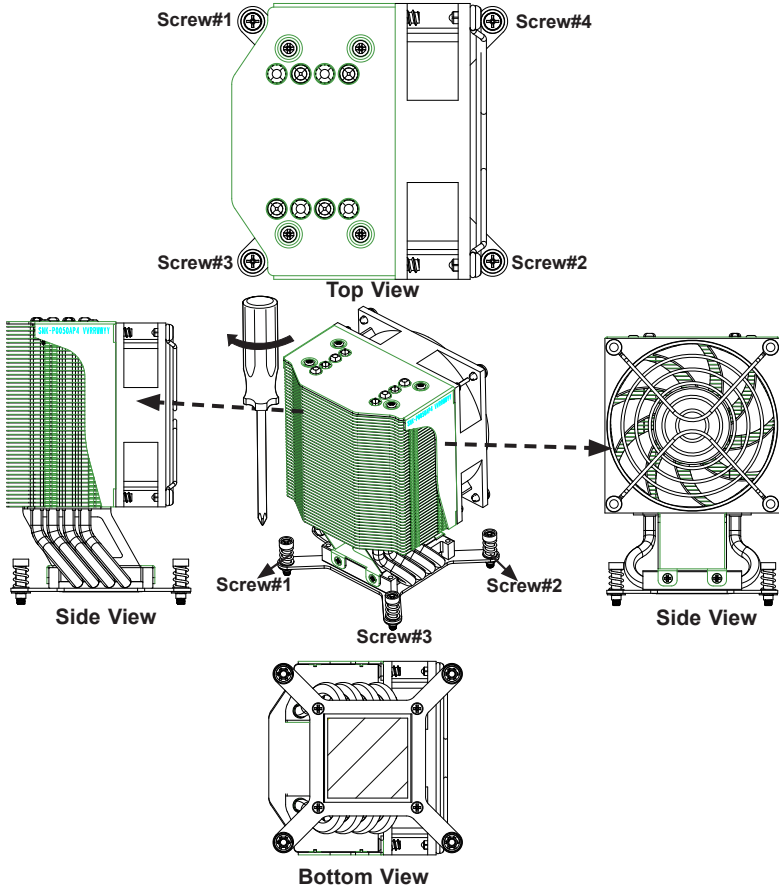

Removing the Heatsink

Caution: We do not recommend that the CPU or the heatsink be removed. However, if you do need to uninstall the heatsink, please follow the instructions below to uninstall the heatsink to prevent damage done to the CPU or the CPU socket. Additional warnings and cautions can be found on the Supermicro Web site at http://www.supermicro.com/about/policies/safety_information.cfm.

1. Remove the power cord from the system before removing the heatsink.
2. Unscrew the heatsink screws from the motherboard in the sequence as shown in the illustration below.
3. Gently wriggle the heatsink to loosen it from the CPU. (Do not use excessive force when wriggling the heatsink!)
4. Once the heatsink is loosened, remove it from the CPU socket.
5. Remove the used thermal grease and clean the surface of the CPU and the heatsink. Reapply the proper amount of thermal grease on the surface before reinstalling the heatsink.

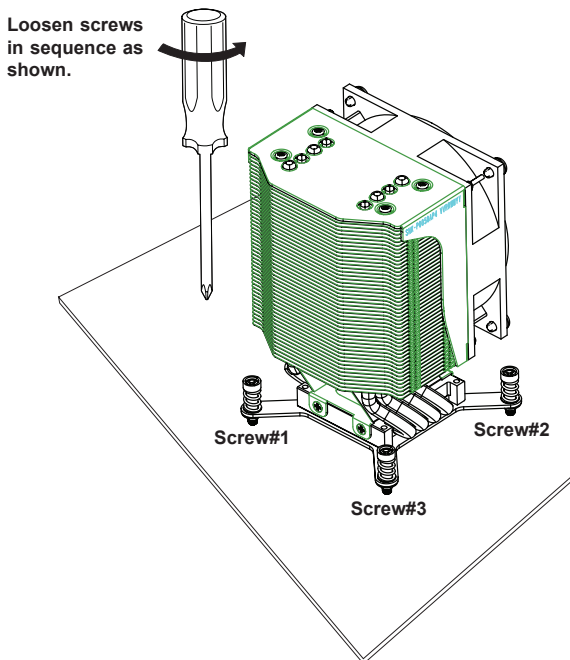

5-5 Installing Memory Modules

Installing Memory Modules

1. Insert the desired number of DIMMs into the memory slots as follows, starting with P1-DIMMA1. For best memory performance, please install memory modules of the same type and speed on the memory slots as indicated on the tables below.
2. Push the release tabs outwards on both ends of the DIMM slot to unlock.
3. Insert each DIMM module vertically into its slot. Pay attention to the notch along the bottom of the module to avoid installing incorrectly (see Figure 5-3).
4. Gently press down on the DIMM module until it snaps into place in the slot. Repeat to populate more sockets as needed.

Figure 5-3. DIMM Installation

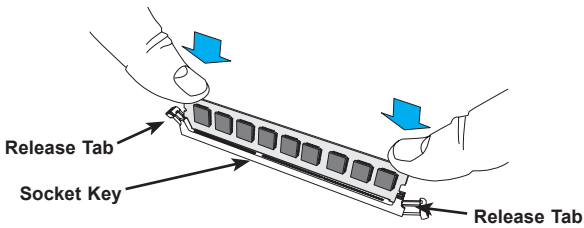

Warning: Exercise extreme care when installing or removing DIMM modules to prevent any possible damage.

Memory Support

The X10SRA supports up to 512GB of ECC LRDIMM, 256GB of ECC RDIMM, or 64GB of ECC/non-ECC UDIMM DDR4-2133/1866/1600/1333 memory in eight DIMM slots. For the latest memory updates, please refer to the product page on the Supermicro website.

Memory Population Guidelines

When installing memory modules, the DIMM slots should be populated in the following order: DIMMA1, DIMMB1, DIMMC1, DIMMD1 then DIMMA2, DIMMB2, DIMMC2, DIMMD2. Always use DDR4 DIMM modules of the same size, type and speed.

Memory Population Examples (Balanced)								
DIMMA1	DIMMB1	DIMMC1	DIMMD1	DIMMA2	DIMMB2	DIMMC2	DIMMD2	Total System Memory
4GB	4GB							8GB
4GB	4GB	4GB	4GB					16GB
4GB	4GB	4GB	4GB	4GB	4GB			24GB
4GB	4GB	4GB	4GB	4GB	4GB	4GB	4GB	32GB
8GB	8GB							16GB
8GB	8GB	8GB	8GB					32GB
8GB	8GB	8GB	8GB	8GB	8GB			48GB
8GB	8GB	8GB	8GB	8GB	8GB	8GB	8GB	64GB

Note: Populating these DIMM modules with a pair of memory modules of the same type and same size will result in interleaved memory, which will improve memory performance.

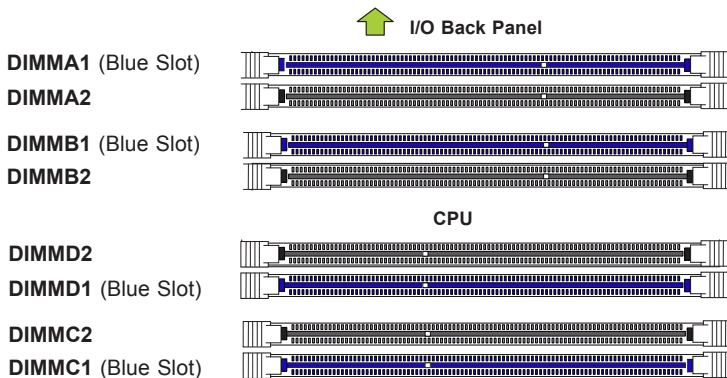

5-6 Adding PCI Add-On Cards

The 5038A-I can accommodate standard size add-on cards populated in all slots on the X10SRA motherboard.

Installing an Add-on Card

1. Begin by removing the PCI slot shield for the slot you wish to populate.
2. Fully seat the card into the card slot, pushing down with your thumbs evenly on both sides of the card.
3. Finish by using a screw to secure the top of the card shield to the chassis. The PCI slot shields protect the motherboard and its components from EMI and aid in proper ventilation, so make sure there is always a shield covering each unused slot.

5-7 Motherboard Details

Figure 5-4. X10SRA Layout

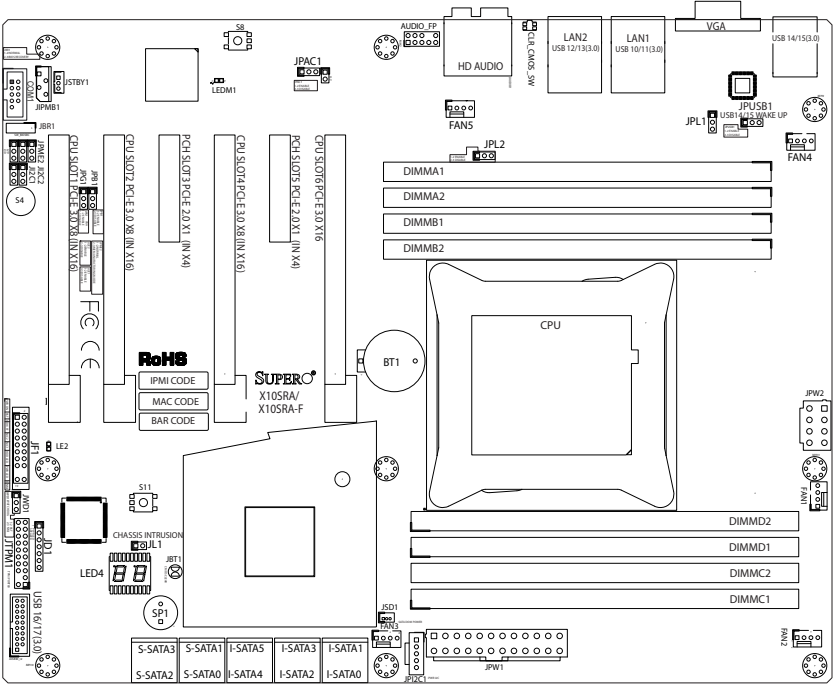

X10SRA Quick Reference

LED	Description	Color/State	Status
LED4	Status Display	Digital Readout	Refer to Status Codes*
LE2	Power LED	On: Steady	System On and Running

*Download the AMI status codes at http://www.ami.com/support/doc/ami_aptio_4_x_status_codes_pub.pdf

Note: jumpers and connections not indicated are for debug purposes or are included on the X10SRA-F board only.

Connector	Description
Audio FP	Front Panel Audio Header
BT1	Onboard Battery
Fan 1,2,3,4,5	System/CPU Fan Headers (Fan1: CPU Fan)
JD1	Speaker/Buzzer Header
JF1	Front Control Panel Header
JPW1	24-pin ATX Main Power Connector
JPW2	+12V 4-pin CPU power Connector
JSD1	SATA DOM (Disk On Module) Power Connector
JSTBY1	Standby Power Header
I-SATA0~5	SATA 3.0 Ports (supports RAID 0, 1, 5 & 10)
S-SATA0~3	SATA 3.0 Ports (no RAID support)
USB 16/17	Front Panel Accessible USB 3.0 Headers
S4	Power Button
S11	BIOS Restore
S8	Clear CMOS Button
JPI2C1	Power Supply SMBbus I2C Header.
JTPM1	Trusted Platform Module Header
COM1	Serial Port Header
JIPMB1	System Management Bus Header (for IPMI only)

Jumper	Description	Default
JBT1	Clear CMOS	See Section 5-9
JI ² C1/JI ² C2	SMB to PCI Slots Enable/Disable	Off (Disabled)
JPAC1	Audio Enable/Disable	Pins 1-2 (Enabled)
JPL1/JPL2	LAN1/LAN2 Enable/Disable	Pins 1-2 (Enabled)
JPME2	Intel Recovery Mode Enable/Disable	Pins 2-3 (Disabled)
JWD1	Watch Dog	Pins 2-3 (NMI)
JBR1	BIOS Recovery Mode Enable/Disable	Pins 2-3 (Disabled)
JPUSB1	USB Wake Up Enable/Disable	Pins 1-2 (Enabled)

5-8 Connector Definitions

ATX Main PWR (JPW1) and CPU PWR Connectors (JPW2)

The 24-pin main power connector (JPW1) is used to provide power to the motherboard. The 8-pin CPU PWR connector (JPW2) is also required for the processor. These power connectors meet the SSI EPS 12V specification. See the table on the right for pin definitions.

ATX Power 24-pin Connector Pin Definitions (JPW1)			
Pin#	Definition	Pin #	Definition
13	+3.3V	1	+3.3V
14	-12V	2	+3.3V
15	COM	3	COM
16	PS_ON	4	+5V
17	COM	5	COM
18	COM	6	+5V
19	COM	7	COM
20	Res (NC)	8	PWR_OK
21	+5V	9	5VSB
22	+5V	10	+12V
23	+5V	11	+12V
24	COM	12	+3.3V

12V 8-pin Power Connector Pin Definitions	
Pins	Definition
1 through 4	Ground
5 through 8	+12V

Power Button

The Power Button connection is located on pins 1 and 2 of JF1. Momentarily contacting both pins will power on/off the system. This button can also be configured to function as a suspend button (with a BIOS setting). To turn off the power in the suspend mode, press the button for at least 4 seconds. Refer to the table on the right for pin definitions.

Power Button Pin Definitions (JF1)	
Pin#	Definition
1	Power Button
2	GND

Power Fail

Connect an LED cable to the Power Fail connection to provide a warning that a power failure has occurred. Refer to the table on the right for pin definitions.

Power Fail LED Pin Definitions (JF1)	
Pin#	Definition
5	3.3V
6	Power Fail LED

Overheat (OH)/Fan Fail

Connect an LED cable to OH/Fan Fail connections on pins 7 and 8 of JF1 to provide warnings for chassis overheat/fan failure. Refer to the table on the right for pin definitions.

OH/Fan Fail LED Pin Definitions (JF1)	
Pin#	Definition
7	3.3V
8	OH/Fan Fail LED

OH/Fan Fail Indicator Status	
State	Definition
Off	Normal
On	Overheat
Flash- ing	Fan Fail

NIC1/NIC2 (LAN1/LAN2)

The NIC (Network Interface Controller) LED connection for LAN port 1 is located on pins 11 and 12 of JF1, and the LED connection for LAN Port 2 is on Pins 9 and 10. NIC1 LED and NIC2 LED are 2-pin NIC LED headers. Attach NIC LED cables to NIC1 and NIC2 LED indicators to display network activities. Refer to the table on the right for pin definitions.

NIC1/NIC2 LED Pin Definitions (JF1)	
Pin#	Definition
9/11	3.3V
10/12	NIC2 LED / NIC1 LED

HDD LED

The HDD LED connection is located on pins 13 and 14 of JF1. Attach a cable here to indicate the status of HDD-related activities, including IDE, SATA activities. See the table on the right for pin definitions.

HDD LED Pin Definitions (JF1)	
Pin#	Definition
13	+3.3V
14	HD Active

Power LED

The Power LED connection is located on pins 15 and 16 of JF1. Refer to the table on the right for pin definitions.

Power LED Pin Definitions (JF1)	
Pin#	Definition
15	+3.3V
16	PWR LED

NMI Button

The non-maskable interrupt button-header is located on pins 19 and 20 of JF1. Refer to the table on the right for pin definitions.

NMI Pin Definitions (JF1)	
Pin#	Definition
19	NMI
20	Ground

Universal Serial Bus (USB)

Six USB 3.0 ports (10/11, 12/13, 14/15) are located on the I/O backpanel. In addition, one USB 3.0 header (USB 16/17) is also located on the motherboard to provide front chassis access using USB cables (not included). These ports are backward compatible with the USB 2.0 standard. See the tables below for pin definitions.

Front Panel USB (3.0) Header #16/17 Pin Definitions			
Pin#	Definition	Pin#	Definition
1	+5V	11	U2DP_B
2	U3RXN_A	12	U2DM_B
3	U3RXP_A	13	Ground
4	Ground	14	U3TXP_B
5	U3TXN_A	15	U3TXN_B
6	U3TXP_A	16	Ground
7	Ground	17	U3RXP_B
8	U2DM_A	18	U3RXN_B
9	U2DP_A	19	+5V
10	USB30_OC signal		

Back Panel USB (3.0) Ports 10/11, 12/13 Pin Definitions			
Pin#	Pin#	Signal Name	Description
1	10	VBUS	Power
2	11	D-	USB 2.0 Differential Pair
3	12	D+	
4	13	Ground	Ground of PWR Return
5	14	StdA_SSRX-	SuperSpeed Receiver
6	15	StdA_SSRX+	Differential Pair
7	16	GND_DRAIN	Ground for Signal Return
8	17	StdA_SSTX-	SuperSpeed Transmitter
9	18	StdA_SSTX+	Differential Pair

Back Panel USB (3.0) Ports 14/15 Pin Definitions			
Pin#	Pin#	Signal Name	Description
B1	A1	VBUS	Power
B2	A2	D-	USB 2.0 Differential Pair
B3	A3	D+	
B4	A4	Ground	Ground of PWR Return
B5	A5	StdA_SSRX-	SuperSpeed Receiver
B6	A6	StdA_SSRX+	Differential Pair
B7	A7	GND_DRAIN	Ground for Signal Return
B8	A8	StdA_SSTX-	SuperSpeed Transmitter
B9	A9	StdA_SSTX+	Differential Pair

Fan Headers

The X10SRA motherboard has five fan headers (Fan1 ~ Fan5). These fans have 4-pin fan headers. Pins 1-3 of the fan headers are backward compatible with the traditional 3-pin fans. However, the fan speed control setting in the BIOS Hardware Monitoring section will only work with 4-pin fans. This allows the BIOS to automatically set fan speeds based on the system temperature. Refer to the table on the right for pin definitions and fan usage. We recommend that 4-pin fans are used on the motherboard.

Fan Header Pin Definitions	
Pin#	Definition
1	Ground (Black)
2	+12V (Red)
3	Tachometer
4	PWM_Control

Speaker

On the JD1 header, Pins 6~7 are used for internal/external speaker. Close pins 6~7 with a cap to use the onboard speaker. If you wish to use an external speaker, attach the external speaker cable to pins 6~7 instead. See the table on the right for pin definitions.

Speaker Connector Pin Definitions for Pins 6-7	
Pin Setting	Definition
Short	Internal Speaker
Attach Ext Speaker Cable	External Speaker

Power Supply I²C

The Power Supply I²C Connector, located at JPI²C, monitors the status of the power supply, fan and system temperature. See the table on the right for pin definitions.

PWR Supply I ² C Pin Definitions	
Pin#	Definition
1	Clock
2	Data
3	PWR Fail
4	Ground
5	3.3V

TPM Header

This header is used to connect a Trusted Platform Module (TPM), which is available from a third-party vendor. A TPM is a security device that supports encryption and authentication in hard drives. It enables the motherboard to deny access if the TPM associated with the hard drive is not installed in the system. See the table on the right for pin definitions.

Trusted Platform Module Header Pin Definitions			
Pin #	Definition	Pin #	Definition
1	LCLK	2	GND
3	LFRAME	4	No Pin
5	LRESET	6	VCC5
7	LAD3	8	LAD2
9	VCC3	10	LAD1
11	LAD0	12	GND
13	RSV0	14	RSV1
15	SB3V	16	SERIRQ
17	GND	18	CLKRUN
19	LPCPD	20	RSV2

DOM PWR Connector

The Disk-On-Module (DOM) power connector, located at JSD1, provides 5V (Gen1/Gen) power to a solid state DOM storage device connected to one of the SATA ports. See the table on the right for pin definitions.

DOM PWR Pin Definitions	
Pin#	Definition
1	5V
2	Ground
3	Ground

Standby Power Header

The Standby Power header is located at STBY1 on the motherboard. See the table on the right for pin definitions.

Standby Power Pin Definitions	
Pin#	Definition
1	+5V Dual
2	Ground
3	Wake-up

Serial Ports

A COM1 header is located near PCI-E slot 1 on the motherboard. The COM1 header provides an onboard serial connection.

Ethernet Ports

Two Ethernet ports (LAN1/LAN2) are located next to the HD Audio Connector on the I/O backpanel. These ports accept RJ45 type cables.

Front Panel Audio Header (AUDIO FP)

A 10-pin Audio header is supported on the motherboard. This header allows you to connect the motherboard to a front panel audio control panel, if needed. Connect an audio cable to the audio header to use this feature (not supplied). See the table at right for pin definitions for the header.

10-in Audio Pin Definitions	
Pin#	Signal
1	Microphone_Left
2	Audio_Ground
3	Microphone_Right
4	Audio_Detect
5	Line_2_Right
6	Ground
7	Jack_Detect
8	Key
9	Line_2_Left
10	Ground

Back Panel High Definition Audio (HD Audio)

The motherboard features a 5.1+2 Channel High Definition Audio (HDA) codec that provides 10 DAC channels. The HD Audio connections simultaneously supports multiple-streaming 5.1 sound playback with 2 channels of independent stereo output through the front panel stereo out for front, rear, center and subwoofer speakers. Use the Advanced software included in the CD-ROM with your motherboard to enable this function.



HD Audio Ports	
1. Center/LFE Out	4. Line In
2. Surround Out	5. Line Out
3. S/PDIF Out	6. Mic In

5-9 Jumper Settings

Explanation of Jumpers

To modify the operation of the motherboard, jumpers can be used to choose between optional settings. Jumpers create shorts between two pins to change the function of the connector. Pin 1 is identified with a square solder pad on the printed circuit board. See the motherboard layout pages for jumper locations.

Note: On a two-pin jumper, "Closed" means the jumper is on both pins and "Open" means the jumper is either on only one pin or completely removed.

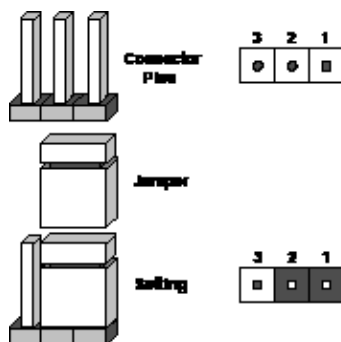

Clear CMOS (JBT1, CLR_CMOS_SW, S8)

JBT1, CLR_CMOS_SW and S8 are used to clear the saved system setup configuration stored in the CMOS chip. To clear the contents of the CMOS, completely shut down the system, remove the AC power cord and then short JBT1 with a jumper or use the push button switch on CLR_CMOS_SW or S8. Remove the jumper before powering on the system again. This will erase all user settings and revert everything to their factory-set defaults.

PCI Slot SMB Enable

Use jumpers J1²C1/J1²C2 to enable PCI SMB (System Management Bus) support to improve system management for the PCI slots. See the table on the right for jumper settings.

PCI Slot SMB Enable Jumper Settings	
Jumper Setting	Definition
Short	Enabled
Open	Disabled

LAN1/LAN2 Enable/Disable

Jumpers JPL1/JPL2 are used to enable or disable LAN ports 1/2, respectively. See the table on the right for jumper settings. The default setting is enabled.

LAN1/2 Enable/Disable Jumper Settings	
Jumper Setting	Definition
Pins 1-2	Enabled
Pins 2-3	Disabled

Watch Dog Reset

Watch Dog (JWD1) is a system monitor that can reboot the system when a software application hangs. Close Pins 1-2 to reset the system if an application hangs. Close Pins 2-3 to generate a non-maskable interrupt signal for the application that hangs. See the table on the right for jumper settings. Watch Dog must also be enabled in the BIOS.

Watch Dog Jumper Settings	
Jumper Setting	Definition
Pins 1-2	Reset
Pins 2-3	NMI
Open	Disabled

USB Wake-Up

Use jumper JPUSB1 to activate the "wake-up" function of the USB ports by pressing a key on an attached USB keyboard or clicking the USB mouse. This jumper is used together with a USB Wake-Up feature in the BIOS. Enable this jumper and the USB support in the BIOS to wake up your system via USB devices.

USB Wake-Up Jumper Settings	
Jumper Setting	Definition
Pins 1-2	Enabled
Pins 2-3	Disabled

Note: JPUSB1 is used with the USB ports on the back panel.

BIOS Restore (Button)

When pressed, the BIOS Restore Button (S11) will look for, and load a file named 'SUPER.ROM' from an installed USB memory device, in any of the USB ports. It will then proceed to update the BIOS. Do NOT turn off the system when BIOS is updating.

Manufacturing Mode

Close pins 2 and 3 of jumper JPME2 to bypass SPI flash security and force the system to operate in Manufacturing Mode, allowing the user to flash the system firmware from a host server for system setting modifications. See the table on the right for jumper settings.

Manufacture Mode Jumper Settings	
Pin#	Definition
Pins 1-2	Normal
Pins 2-3	Manufacture Mode

BIOS Recovery Switch

The BIOS Recovery Switch (JBR1) is used to enable or disable the BIOS Recovery feature of the motherboard. Slide the switch from the default position to begin the recovery process. See Appendix D for details.

BIOS Recovery Jumper Settings	
State	Definition
Open	Normal
Closed	Recover

Power Button (S4)

In addition to the soft power switch provided in JF1, your motherboard is equipped with a 'soft' power button on the motherboard. This switch works the same way as the soft power switch on JF1.

Manufacture Mode Jumper Settings	
Pin#	Definition
Pins 1-2	Normal
Pins 2-3	Manufacture Mode

Audio Enable

JPAC1 allows you to enable or disable the onboard audio support. The default position is on pins 1 and 2 to enable onboard audio connections. See the table on the right for jumper settings.

Audio Enable/Disable Jumper Settings	
Both Jumpers	Definition
Pins 1-2	Enabled
Pins 2-3	Disabled

5-10 Onboard Indicators

LAN Port LEDs

The LAN ports are located on the I/O back-panel of the motherboard. Each Ethernet LAN port has two LEDs. The yellow LED indicates activity, while the Link LED may be green, amber, or off to indicate the speed of the connections. See the tables at right for more information.

LAN Port LEDs Status	
LED Color	Definition
Off	No Connection or 10/100 Mbps
Green	1 Gbps
Amber	10 Gbps

Power LED

LE2 is a status LED to indicate that the motherboard is on and running. See the table on the right for status display definitions.

Power LED Status	
Status	Definition
Off	System is Off
On	System is On

Status Display (LED4)

LED4 is made up of two alpha-numeric displays that will display a status or POST code when the motherboard is powered on. Please download the following AMI publication for a complete list of POST codes:

http://www.ami.com/support/doc/ami_aptio_4.x_status_codes_pub.pdf

5-11 SATA Ports

SATA Ports

Ten Serial ATA (SATA) 3.0 ports (I-SATA0~5, S-SATA0~3) are provided on the motherboard. All SATA 3.0 ports are supported by the Intel C612 PCH chip. RAID 0,1,5,10 are supported on I-SATA 0~5. These high speed ports support transfer rates of up to 6Gb/s.

5-12 Installing Software

The Supermicro ftp site contains drivers and utilities for your system at <ftp://ftp.supermicro.com>. Some of these must be installed, such as the chipset driver.

After accessing the ftp site, go into the CDR_Images directory and locate the ISO file for your serverboard. Download this file to create a CD/DVD of the drivers and utilities it contains. (You may also use a utility to extract the ISO file if preferred.)

Another option is to go to the Supermicro website at <http://www.supermicro.com/products/>. Find the product page for your serverboard here, where you may download individual drivers and utilities.

After creating a CD/DVD with the ISO files, insert the disk into the CD/DVD drive on your system and the display shown in Figure 5-5 should appear.

Figure 5-5. Driver/Tool Installation Display Screen

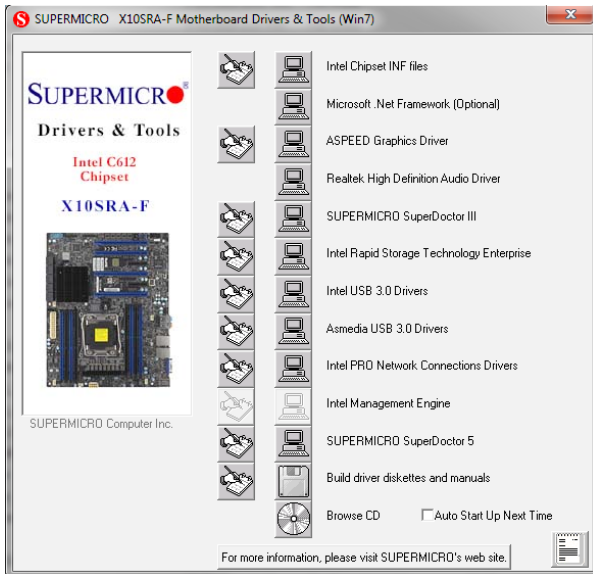

SuperDoctor® 5

The Supermicro SuperDoctor 5 is a program that functions in a command-line or web-based interface in Windows and Linux operating systems. The program monitors system health information such as CPU temperature, system voltages, system power consumption, fan speed, and provides alerts via email or Simple Network Management Protocol (SNMP).

SuperDoctor 5 comes in local and remote management versions and can be used with Nagios to maximize your system monitoring needs. With SuperDoctor 5 Management Server (SSM Server), you can remotely control power on/off and reset chassis intrusion for multiple systems with SuperDoctor 5 or IPMI. SD5 Management Server monitors HTTP, FTP, and SMTP services to optimize the efficiency of your operation.

Note: The default User Name and Password for SuperDoctor 5 is admin / admin.

Figure 5-6. SuperDoctor 5 Interface Display Screen (Health Information)

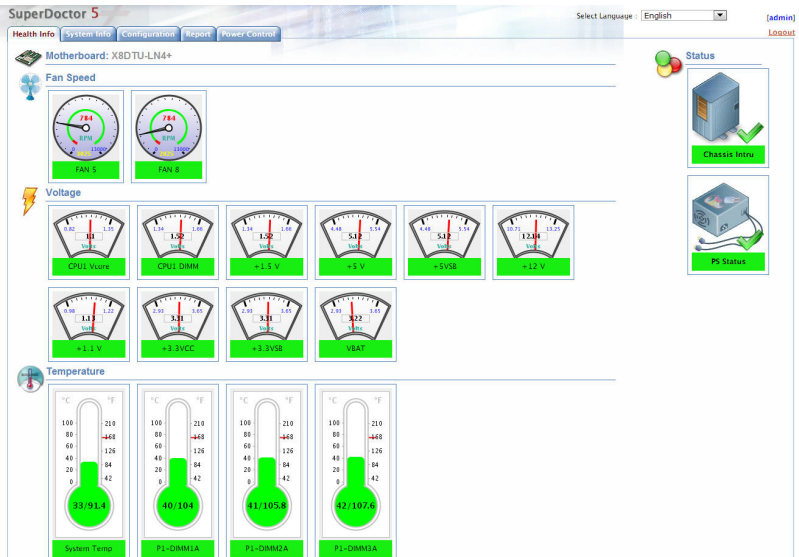

Note: The SuperDoctor 5 program and User's Manual can be downloaded from the Supermicro website at http://www.supermicro.com/products/info/sms_sd5.cfm.

5-13 Onboard Battery

Please handle used batteries carefully. Do not damage the battery in any way; a damaged battery may release hazardous materials into the environment. Do not discard a used battery in the garbage or a public landfill. Please comply with the regulations set up by your local hazardous waste management agency to dispose of your used battery properly.

Figure 5-7. Installing the Onboard Battery

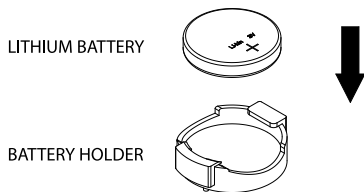

Notes

Chapter 6

Advanced Chassis Setup

This chapter covers the steps required to install components and perform simple maintenance on the SC732D3-903B chassis. Following the component installation steps in the order given will eliminate most common problems. If some steps are unnecessary, skip ahead to the step that follows. The only tool you will need is a Philips screwdriver.

6-1 Static-Sensitive Devices

Static electrical discharge can damage electronic components. To prevent damage to any printed circuit boards (PCBs), handle them very carefully. The following measures are generally sufficient to protect your equipment from static discharge.

Cautions

- Use a grounded wrist strap designed to prevent static discharge.
- Touch a grounded metal object before removing any board from its antistatic bag.
- Handle a board by its edges only; do not touch its components, peripheral chips, memory modules or gold contacts.
- When handling chips or modules, avoid touching their pins.
- Put the motherboard, add-on cards and peripherals back into their antistatic bags when not in use.
- For grounding purposes, make sure your computer chassis provides excellent conductivity between the power supply, the case, the mounting fasteners and the motherboard.

For additional warnings and cautions, see http://www.supermicro.com/about/policies/safety_information.cfm.

6-2 Removing the Power Cord

Before performing any setup or maintenance on the chassis, use the following procedure to ensure that power has been removed disconnected from the system.

Removing the Power Cord

1. Use the operating system to power down the system, following the on-screen prompts.
2. After the system has completely shut-down, carefully grasp the head of the power cord and gently pull it out of the back of the power supply.
3. Disconnect the cord from the power strip or wall outlet.

Figure 6-1. Chassis Front View

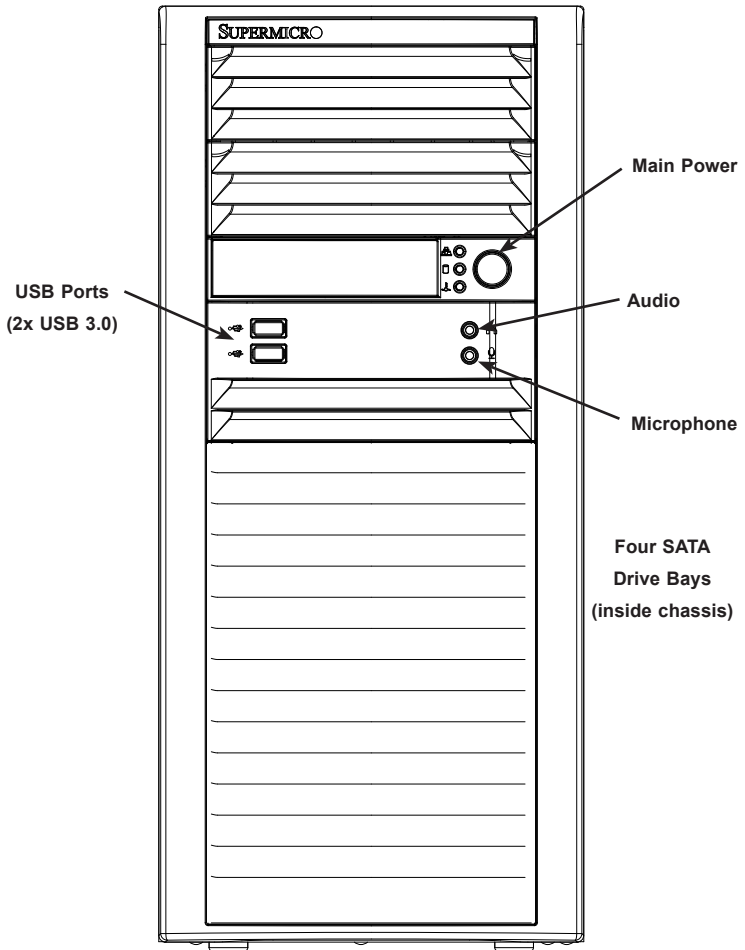

6-3 Front Control Panel

The front control panel must be connected to the JF1 connector on the motherboard to provide you with system status and alarm indications. A ribbon cable has bundled these wires together to simplify this connection.

Connect the cable from JF1 on the motherboard (making sure the red wire plugs into pin 1) to the appropriate connector on the front control panel PCB (printed circuit board). Pull all excess cabling over to the control panel side of the chassis. The LEDs on the control panel inform you of system status - see Figure 6-2 for details. See Chapter 5 for details on JF1.

Figure 6-2. Front Control Panel LEDs

HDD  On the SC732D3-900B, this LED indicates hard drive activity when flashing.

NIC  Indicates network activity on the LAN port.

Information LED  The Information LED is used to indicate an overheat condition, a fan failure, power failure or activation of the UID (Unit Identifier button). See Chapter 3 for details.

6-4 Removing the Chassis Side Covers

Figure 6-3. Removing the Chassis Side Covers

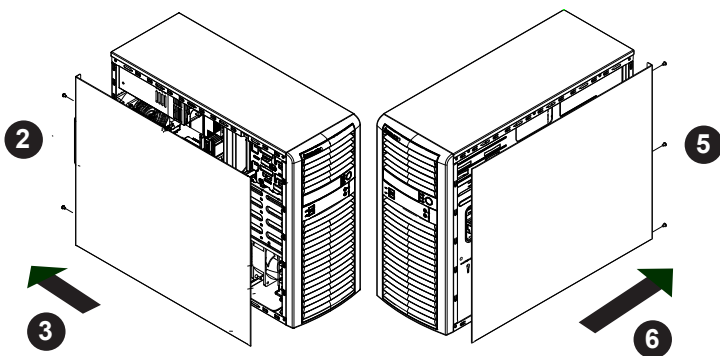

The SC732D3-903B features two removable side covers, allowing easy access to the chassis interior.

Removing the Side Covers

1. Disconnect the chassis from any power source.
2. Remove the two screws securing the left side cover to the chassis.
3. Slide the left cover toward the rear of the chassis.
4. Lift the left cover from the chassis.
5. Remove the three screws securing the right side cover to the chassis.
6. Slide the right cover toward the rear of the chassis.
7. Lift the right cover from the chassis.

Caution: Except for short periods of time, do NOT operate the system without the cover in place. The chassis cover must be in place to allow for proper airflow and to prevent overheating.

Additional warnings and cautions can be found on the Supermicro website at http://www.supermicro.com/about/policies/safety_information.cfm.

6-5 System Fans

One 12-cm exhaust fan is included to expel hot air from the chassis. This is a low-noise fan that results in "Whisper-Quiet" operation (~21 dB). The fans should be connected to headers on the motherboard (see Chapter 5).

The power supply also includes a cooling fan. If a power supply fan fails, you should replace the power supply at your earliest convenience.

Fan Failure

Under normal operation, the exhaust fan and the power supply fan run continuously. The chassis fans are hot-pluggable and can be replaced without powering down the system.

Replacing Optional Chassis Cooling Fans

Removing a Fan

1. First locate the failed chassis fan by removing the top/left chassis cover (see Chapter 2 for details). Locate the fan that has stopped working.
2. Disconnect the power cord to the chassis and disconnect the cable to the fan.
3. Remove the two screws securing the fan bracket to the chassis.
4. Remove the four screws securing the fan to the fan bracket.
5. Lift the fan up and out of the chassis.

Installing a New Fan

1. Replace the failed fan with an identical one (available from Supermicro)
2. Secur the fan to the bracket with four screws and secure the bracket to the chassis with two screws.
3. Install it in the same position and orientation as the one you removed.
4. Check that the fan is working then replace the chassis cover.

Figure 6-4. Removing a Chassis Fan (optional)

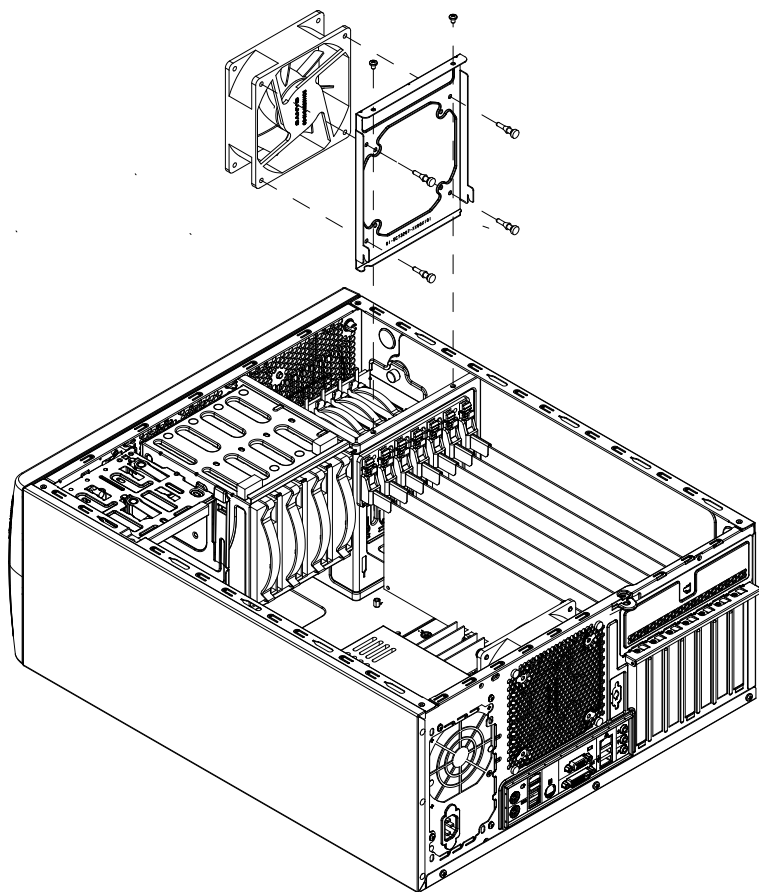

6-6 Drive Installation

A total of four SATA drives may be housed in the SC732D3-903B chassis. Remove the side panel of the chassis to access these drives as described in Section 6-4.

Rotating the Hard Drive Cage

1. Disconnect the chassis from any power source.
2. Lift the release tab (A).
3. Rotate the hard drive cage (B) outward.
4. Press the release tab on the side of the hard drive carrier which is to be removed from the hard drive cage.
5. Gently pull the hard drive carrier out of the cage.
6. If a hard drive is already present, remove it by carefully pulling the sides of the hard drive carrier outward.

Figure 6-5. Removing a SATA Drive Carrier

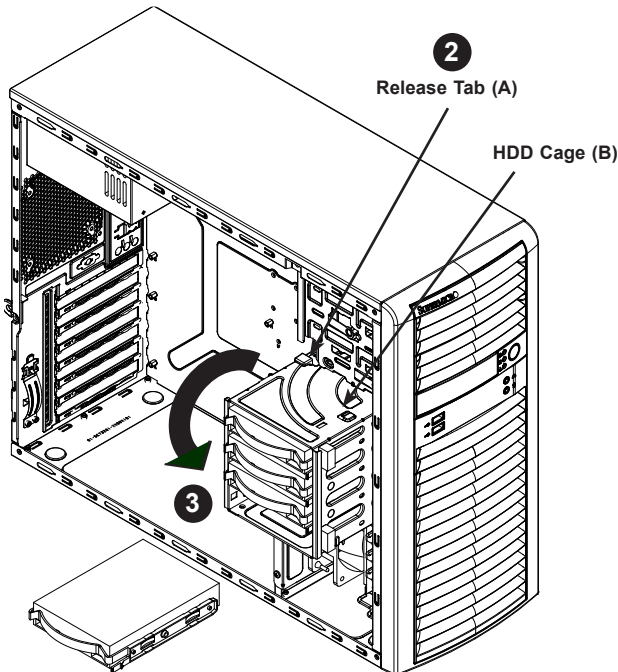
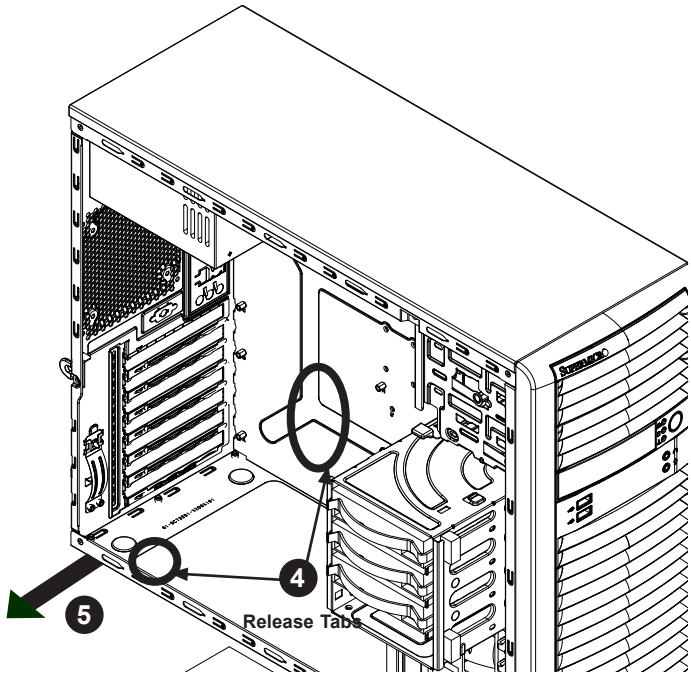
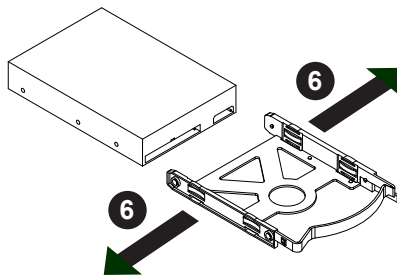

Figure 6-6. Removing the Hard Drive Carrier from the Hard Drive Cage



7. Remove the hard drive from the hard drive carrier.
8. Insert the new hard drive into the hard drive carrier.

Figure 6-7. Removing the 3.5" Hard Drive from the Hard Drive Carrier



Note: Enterprise level hard disk drives are recommended for use in Supermicro chassis and servers. For information on recommended HDDs, visit the Supermicro Web site at <http://www.supermicro.com/products/nfo/storage.cfm>

Figure 6-8. Installing the Hard Drive Carrier into the Hard Drive Cage

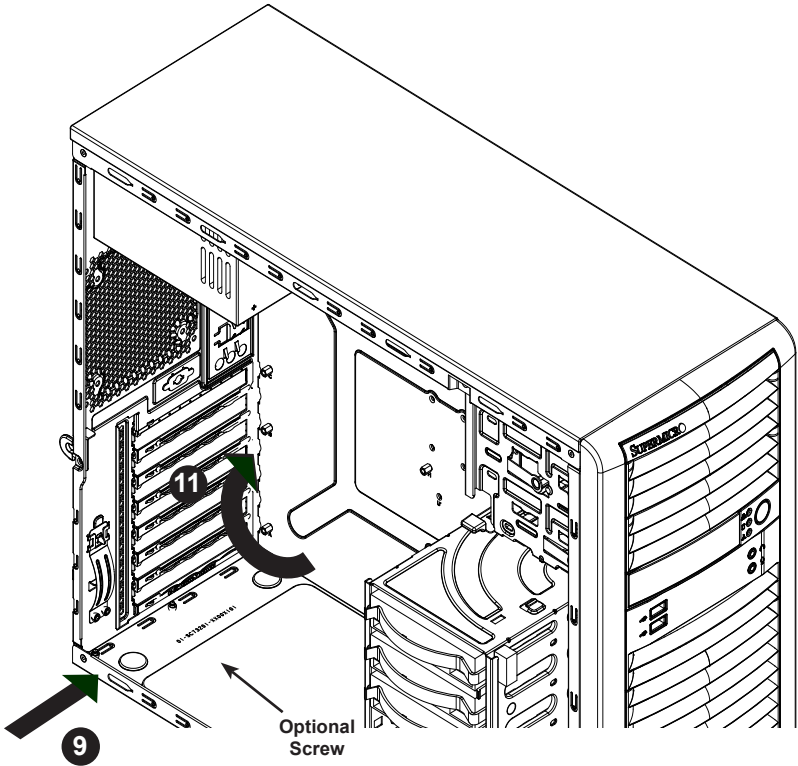

9. Insert the hard drive carrier into the hard drive cage, sliding it towards the back of the the hard drive cage until it clicks into a locked position.
10. If desired, each hard drive carrier may be secured to the exterior of the hard drive cage using one optional screw.
11. Rotate the hard drive cage 90 degrees inward, returning it to the closed, operational position in the chassis.
12. Connect the related cables to the hard drives.

6-7 Removing and Installing Optional 2.5" Hard Drives

Figure 6-9. Removing the 2.5" Hard Drives

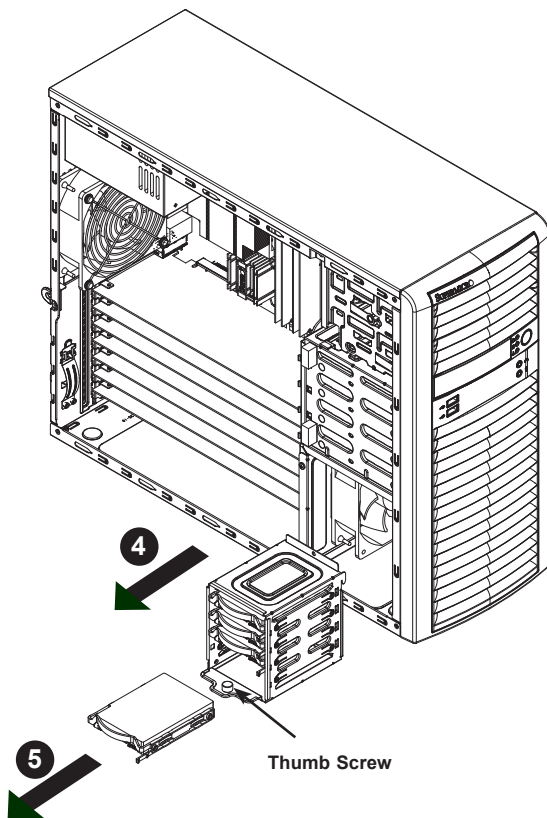

The 5038A-I must be powered-down before hard drives can be removed.

Removing and Installing 2.5" Hard Drives

1. Disconnect the chassis from any power source.
2. Loosen the thumb screw securing the 2.5" hard drive cage to the chassis.
3. Disconnect all cables from the hard drive.
4. Slide the 2.5" hard drive cage out of the chassis.
5. If a hard drive is already present, remove it by carefully pulling the sides of the hard drive carrier outward.

Figure 6-10. Installing 2.5" Hard Drives (optional)

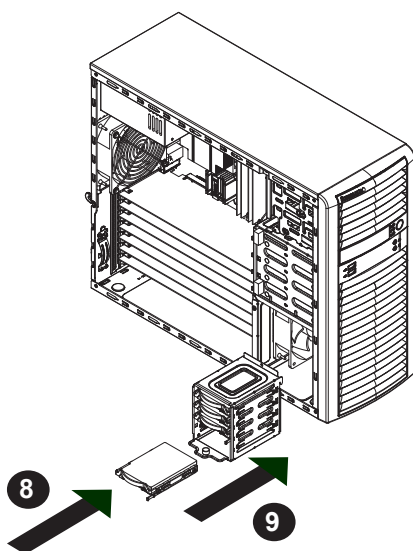

6. Remove the hard drive from the hard drive carrier.
7. Insert the new hard drive into the hard drive carrier.
8. Insert the carrier into the hard drive cage, sliding it towards the back of the hard drive cage until it clicks into a locked position.
9. Slide the 2.5" hard drive cage back into the chassis and tighten the thumb screw to secure the cage.
10. Connect the related cables to the hard drive

Warning: Only enterprise level HDDs are recommended for use in this chassis. Additional warnings and cautions can be found on the Supermicro website at http://www.supermicro.com/about/policies/safety_information.cfm.

6-8 Power Supply

The 5038A-I includes a 900 watt power supply. In the unlikely event that it becomes necessary to replace the power supply, follow the instructions below.

Figure 6-11. Removing the Power Supply

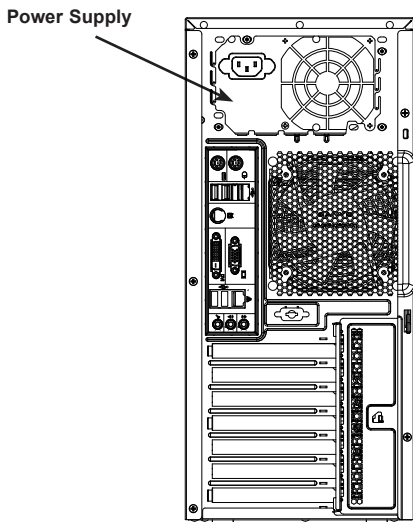

Changing the Power Supply

1. Disconnect the chassis from any power source.
2. Disconnect the motherboard cables.
3. Remove the screws securing the power supply to the chassis, which are located on the rear of the chassis. Set these screws aside for later use.
4. Gently lift the power supply out of the chassis.
5. Replace the failed power supply with an identical power supply model.
6. Secure the new power supply using the screws previously set aside.
7. Plug the AC power cord back into the module and power-up the system.

Notes

Chapter 7

BIOS

7-1 Introduction

This chapter describes the AMI BIOS Setup Utility for the X10SRA/X10SRA-F motherboard. The ROM BIOS is stored in a Flash EEPROM and can be easily updated. This chapter describes the basic navigation of the AMI BIOS Setup Utility setup screens.

Note: For AMI BIOS Recovery, please refer to the UEFI BIOS Recovery Instructions in Appendix C.

Starting BIOS GUI Setup Utility

To enter the AMI BIOS GUI Setup Utility screens, press the <Delete> key while the system is booting up.

Note: In most cases, the <Delete> key is used to invoke the AMI BIOS setup screen.



Each BIOS menu option is described in this manual. The Main BIOS Setup screen has two main areas. The top area is the Main Navigation, and the main area is for the Setup Section. Icons that do not respond when the mouse pointer is hovering on top are not configurable.

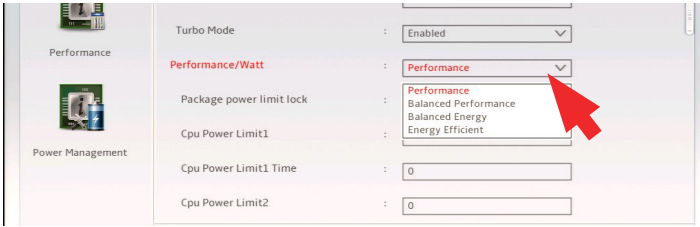

The AMI BIOS GUI Setup Utility uses a mouse pointer navigation system similar to standard graphical user interfaces. Hover and click an icon to select a section, click a down arrow to select from an options list.

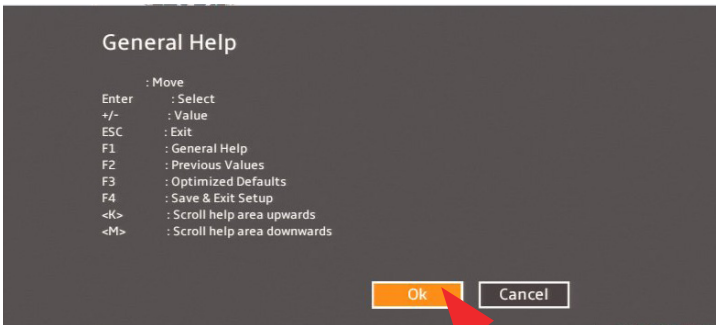

Except for the Home screen you may press the <F1> on any screen under the Setup Section to see a list of Hot Keys that are available.

How To Change the Configuration Data

The configuration data that determines the system parameters may be changed by entering the AMI BIOS GUI Setup utility. This Setup utility can be accessed by pressing at the appropriate time during system boot.

Note: For the purposes of this manual, options that are printed in **Bold** are default settings.

How to Start the Setup Utility

Normally, the only visible Power-On Self-Test (POST) routine is the memory test. As the memory is being tested, press the <Delete> key to enter the main menu of the AMI BIOS GUI Setup Utility. From the Setup Home screen, you can access the other Setup Sections.

7-2 Setup Home

The first screen of the AMI BIOS GUI Setup Utility is the Setup Home screen. You can always return to the Setup Home screen by clicking the Home icon on the top of the screen. The Setup Home screen is shown below.



The Boot menu item jumps directly to the Setup's Boot Section, which is described in detail later in this manual.



By default, some advanced menu options are hidden from display. Clicking Expert Mode ON or OFF will display or hide these options from the menu. In this chapter, all Expert Mode option items are **bold and underlined**.



The Save and Load icon brings up a pop-up menu that enables the user to choose from different saving options at the end of the session.



Load Optimized Defaults

To set this feature, select Load Optimized Defaults from the Save & Load menu and press <Enter>. These are factory settings designed for maximum system performance but not for maximum stability.

Save All Settings Only

When you have completed the system configuration changes, select this option to save all changes made. This will not reset (reboot) the system and will not exit.

Exit Without Save

Select this option to quit the BIOS Setup without making any permanent changes to the system configuration, and reboot the computer.

Save and Reset

When you have completed the system configuration changes, select this option to save the changes, leave the BIOS Setup Utility, and reboot the computer for the new system configuration parameters can take effect.

Save and Exit Setup

When you have completed the system configuration changes, select this option to save the changes, and leave the BIOS Setup Utility.

7-3 System Information

The System Information Screen displays the motherboard's configuration.

Motherboard



The following information are displayed in this section:

- **Motherboard Model Name** - X10SRA (-F).
- **BIOS Version** - this item displays the BIOS version number.
- **Build Date** - displays the BIOS build date.

System Date

This item sets and displays the system date. Click the up and down arrows to adjust the date.

System Time

This item sets and displays the system time. Click the up and down arrows to adjust the system time.

CPU



The following information are be displayed in this section:

- **Type and Speed of CPU** - indicates the brand, model name, model number of the CPU and it's rated clock speed.
- **CPU Signature** - displays the unique signature embedded in the CPU.
- **CPU Speed** - this item shows the current CPU speed.
- **Microcode Patch** - displays the CPU's microcode patch version.

Memory



The following information are be displayed in this section:

- **Total Memory** - shows the total detected system memory.
- **Memory Frequency** - displays the system memory's detected speed.

PCH



The following information are be displayed in this section:

- **PCH Name** - displays the name of the PCH chip (if detected).
- **PCH Stepping**- shows the PCH chip's stepping number.

7-4 Processor (CPU)

Set all options for the processor in this section.

Information

The following CPU information will be displayed:



- **CPU Model Number and Clock Frequency**
- **CPU Signature** - displays the unique signature embedded in CPU.
- **CPU Speed** - displays the CPU's rated speed.
- **Microcode Patch** - displays the CPU's microcode patch version.
- **L1 Cache** - displays the L1 cache size.
- **L2 Cache** - displays the L2 cache size.
- **L3 Cache** - displays the L3 cache size.

Performance

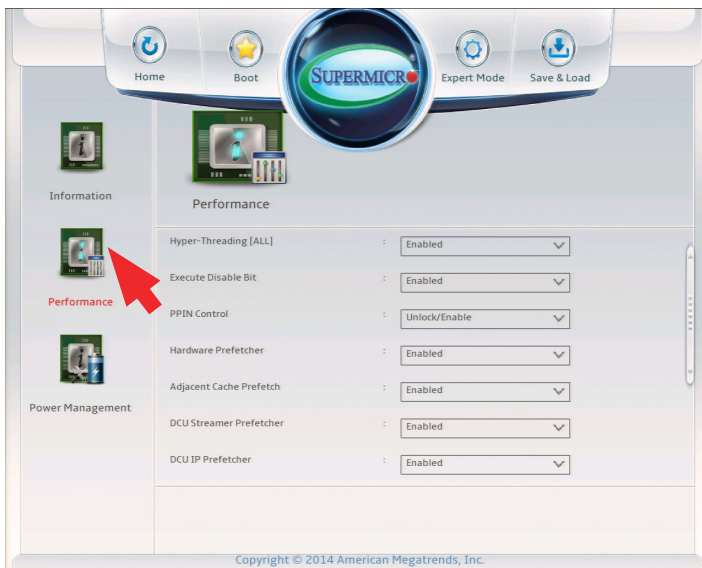

Hyper-threading [ALL]

Select Enabled to support Intel Hyper-threading Technology to enhance CPU performance. The options are **Enabled** and Disabled.

Execute-Disable Bit Capability (Available if supported by the OS & the CPU)

Select Enabled to enable the Execute-Disable Bit which will allow the processor to designate areas in the system memory where an application code can execute and where it cannot, thus preventing a worm or a virus from flooding illegal codes to overwhelm the processor or damage the system during an attack. The default is **Enabled**. (Refer to Intel and Microsoft Web sites for more information.)

PPIN Control

Select Enable to unlock the PPIN control. The options are **Enabled** and Disabled.

Hardware Prefetcher (Available when supported by the CPU)

If set to Enabled, the hardware prefetcher will prefetch streams of data and instructions from the main memory to the L2 cache to improve CPU performance. The options are Disabled and **Enabled**.

Adjacent Cache Line Prefetch (Available when supported by the CPU)

The CPU prefetches the cache line for 64 bytes if this feature is set to Disabled. The CPU prefetches both cache lines for 128 bytes as comprised if this feature is set to **Enabled**.

DCU Streamer Prefetcher (Available when supported by the CPU)

Select Enabled to enable the DCU (Data Cache Unit) Streamer Prefetcher which will stream and prefetch data and send it to the Level 1 data cache to improve data processing and system performance. The options are Disabled and **Enabled**.

DCU IP Prefetcher (Available when supported by the CPU)

Select Enabled for DCU (Data Cache Unit) IP Prefetcher support, which will prefetch IP addresses to improve network connectivity and system performance. The options are Disabled and **Enabled**.

Direct Cache Access (DCA Support)

Select Enabled to use Intel's DCA (Direct Cache Access) Technology to improve data transfer efficiency. The options are **Enabled** and Disabled.

X2APIC

Select Enable to activate APIC (Advanced Programmable Interrupt Controller) support. The options are **Enabled** and Disabled.

AES-NI

Select Enable to use the Intel Advanced Encryption Standard (AES) New Instructions (NI) to ensure data security. The options are **Enabled** and Disabled.

Intel® Virtualization Technology

Select Enabled to support Intel Virtualization Technology, which will allow one platform to run multiple operating systems and applications in independent partitions, creating multiple "virtual" systems in one physical computer. The options are **Enabled** and Disabled.

Note: If a change is made to this setting, you will need to reboot the system for the change to take effect. Refer to Intel's website for detailed information.

Power Management

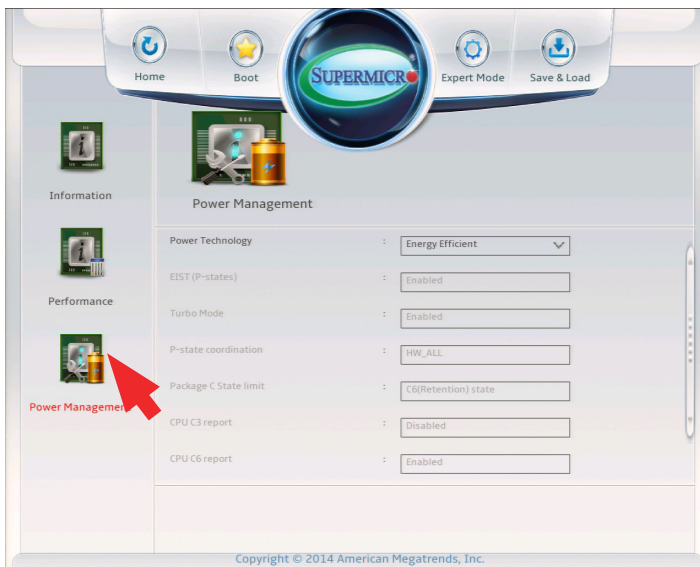

Power Technology

Select Energy Efficiency to support power-saving mode. Select Custom to customize system power settings. Select Disabled to disable power-saving settings. The options are Disable, **Energy Efficiency**, and Custom.

If the above is set to 'Custom' the following options are displayed:

EIST

EIST (Enhanced Intel SpeedStep Technology) allows the system to automatically adjust processor voltage and core frequency in an effort to reduce power consumption and heat dissipation. **Please refer to Intel's web site for detailed information.** The options are Disabled and **Enabled**.

Turbo Mode

This feature allows processor cores to run faster than the frequency recommended by the manufacturer. The options are Disabled and **Enabled**.

P-STATE Coordination

This feature selects the type of coordination for the P-State of the processor. P-State is a processor operational state that reduces the processor's voltage and frequency. This makes the processor more energy efficient, resulting in further energy gains. The options are HW_ALL, SW_ALL and SW-ANY.

Package C-State limit

This feature allows the user to set the limit on the C-State package register. The options are C0/C1 State, C2 State, C6 (Non Retention) State, and **C6 (Retention) State**.

CPU C3 Report

Select Enabled to allow the BIOS to report the CPU C3 State (ACPI C2) to the operating system. During the CPU C3 State, the CPU clock generator is turned off. The options are Enabled and **Disabled**.

CPU C6 Report

Select Enabled to allow the BIOS to report the CPU C6 State (ACPI C3) to the operating system. During the CPU C6 State, the power to all cache is turned off. The options are **Enabled** and Disabled.

Enhanced Halt State (C1E)

Select Enabled to use Enhanced Halt-State technology, which will significantly reduce the CPU's power consumption by reducing the CPU's clock cycle and voltage during a Halt-state. The options are Disable and **Enable**.

7-5 Chipset

Set all options for the Chipset in this section.

System Agent



The following will be displayed:

- **System Agent Bridge Name** - this displays the System Agent bridge name.
- **System Agent RC Version** - indicates the System Agent RC version.
- **VT-d Capability** - this item indicates whether VT-d is supported.

Enable IOAT

Select Enable to enable Intel I/OAT (I/O Acceleration Technology) support, which significantly reduces CPU overhead by leveraging CPU architectural improvements and freeing the system resource for other tasks. The options are **Enable** and Disable.

No Snoop

Select Enable to support no-snoop mode for each CB device. The options are **Disable** and Enable.

Relaxed Ordering

Select Enable to enable Relaxed Ordering support which will allow certain transactions to violate the strict-ordering rules of PCI bus for a transaction to be completed prior to other transactions that have already been enqueued. The options are **Disable** and Enable.

Intel VT for Directed I/O (VT-d)

Select Enabled to enable Intel Virtualization Technology support for Direct I/O VT-d by reporting the I/O device assignments to the Virtual Machine Manager (VMM) through the DMAR ACPI Tables. This feature offers fully-protected I/O resource-sharing across the Intel platforms, providing the user with greater reliability, security and availability in networking and data-sharing. The settings are **Enabled** and Disabled.

Interrupt Remapping

Select Enable for Interrupt Remapping support to enhance system performance. The options are **Enable** and Disable.

PCH I/O



The following will be displayed:

- **PCH Name** - this displays the chipset name.
- **PCH RC Version** - indicates the PCH RC version.
- **PCH Stepping** - this item displays the PCH stepping..

Azalia (HD Audio)

This item controls the detection of the Azalia (HD Audio) device. The settings are Enabled and **Disabled**.

On Board Chip



Onboard USB Controller (USB 14/15)

This feature Enables or Disables the USB controller for USB ports 14/15. The options are Disabled and **Enabled**.

Onboard USB Controller (USB 16/17)

This feature Enables or Disables the USB controller for USB ports 16/17. The options are Disabled and **Enabled**.

USB Wake up from S5 Support (USB 14/15)

This feature Enables or Disables the ability of the system to 'wake-up' from the S5 sleep state through USB port 14/15. The options are Disabled and **Enabled**.

7-6 Memory

Set all options for the System Memory in this section.

Memory Information

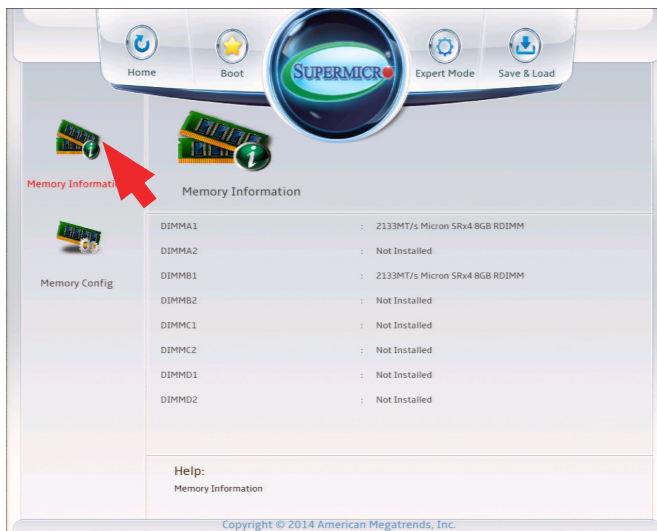

This item information on the memory modules installed on the motherboard.

- **DIMMA1~DIMMD2** - this item displays the type of memory that are detected for each memory slot.

Memory Configuration

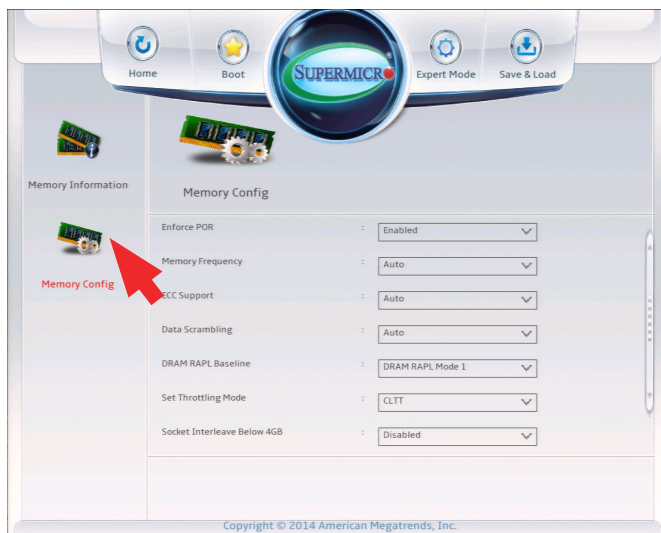

Enforce POR

Select Enable to enforce POR restrictions on DDR4 frequency and voltage programming. The options are **Enabled** and Disabled.

Memory Frequency

Use this feature to set the maximum memory frequency for onboard memory modules. The options are **Auto**, 1333, 1400, 1600, 1800, 1867, 2000, 2133, 2200, 2400, 2600, and 2667.

Data Scrambling

Select Enabled to enable data scrambling to enhance system performance and data integrity. The options are **Auto**, Disabled and Enabled.

DRAM RAPL Baseline

Use this feature to set the run-time power-limit baseline for DRAM modules. The options are Disable, DRAM RAPL Mode 0, and **DRAM RAPL Mode 1**.

Set Throttling Mode

Use this feature to activate Closed Loop Thermal Throttling (CLTT), which uses the DIMM memory temperature as input to make adjustments to the throttling based on variations in system's fan speed. The options are Disabled, and **CLTT**.

Socket Interleave Below 4GB

Select Enabled for the memory above the 4G Address space to be split between two sockets. The options are Enable and **Disable**.

A7 Mode

Select Enabled to support the A7 (Addressing) mode to improve memory performance. The options are **Enable** and Disable.

7-7 Hardware Monitor

This section is supported on the X10SRA motherboard only, or in the case of the X10SRA-F, will only appear if jumper JPB1 is set to disabled (pins 2-3).

Temperature

The following temperatures from different sensors on the motherboard will be displayed:

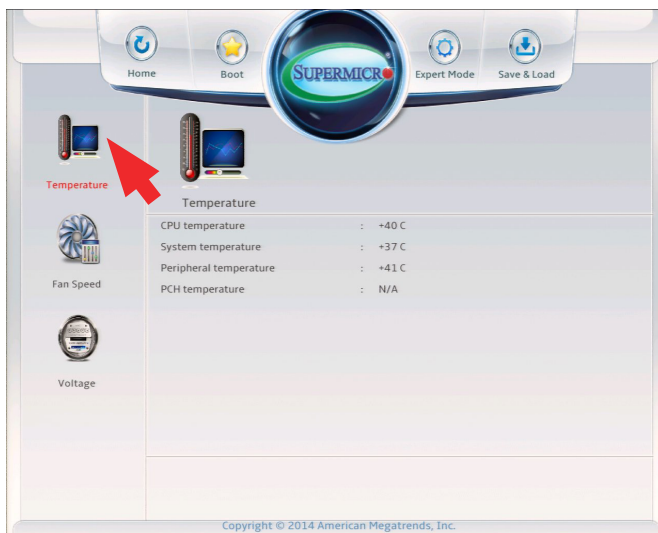

- **CPU Temperature** - CPU temperature reading in Celsius.
- **System Temperature** - System temperature reading in Celsius.
- **Peripheral Temperature** - Peripheral temperature reading in Celsius.
- **PCH Temperature** - PCH temperature reading in Celsius.

Fan Speed



Fan Speed Control Mode

The Fan Speed Control Mode sets the speed of the system fans to either Full Speed (100% of PWM cycle), Heavy I/O or Standard speed (50% of PWM cycle, temperature controlled). Select Heavy I/O mode when IO devices are under heavy load. The options are **Standard**, Heavy I/O, and Full Speed.

The following will be displayed:

- **Fan1 Speed ~ Fan5 Speed** - detected fan speed, in RPM.

Voltage



The Voltage section detects and displays the different detected voltage levels from different sensors within the motherboard.

The following will be displayed:

- **VCPU, 12V, VDIMM, 5VCC, PCH 1.05V, AVCC, 3.3VCC, VSB, VBAT** - the current detected voltage is displayed.

7-8 I/O

Set all options for the I/O in this section.

SATA

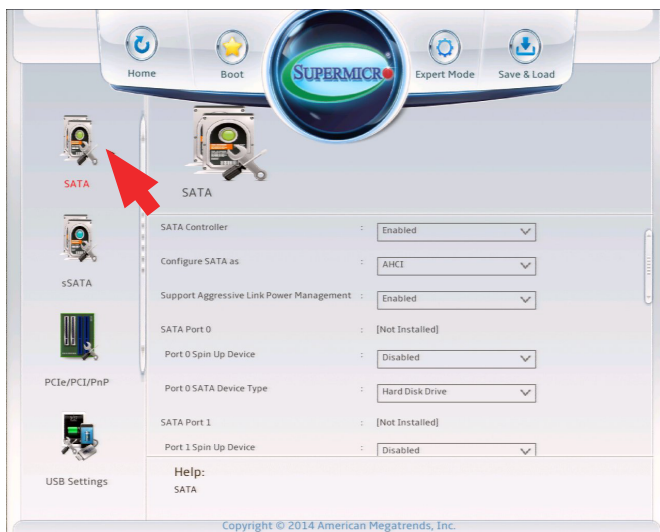

SATA Controller

This item enables or disables the onboard SATA controller supported by the Intel PCH chip. The options are **Enabled** and Disabled.

Configure SATA as

Select IDE to configure a SATA drive specified by the user as an IDE drive. Select AHCI to configure a SATA drive specified by the user as an AHCI drive. Select RAID to configure a SATA drive specified by the user as a RAID drive. The options are IDE, **AHCI**, and RAID.

**If the item above "Configure SATA as" is set to AHCI, the following items will display:*

Support Aggressive Link Power Management

When this item is set to Enabled, the SATA AHCI controller manages the power usage of the SATA link. The controller will put the link to a low power state when the I/O is inactive for an extended period of time, and the power state will return to normal when the I/O becomes active. The options are **Enabled** and Disabled.

SATA Port 0 ~ SATA Port 5

This item displays the information detected on the installed SATA drive on the particular SATA port.

- Model number of drive and capacity

Port 0 ~ Port 5 Spin Up Device

On an edge detect from 0 to 1, set this item to allow the PCH to initialize the device. The options are Enabled and **Disabled**.

Port 0 ~ Port 5 SATA Device Type

Use this item to specify if the SATA port specified by the user should be connected to a Solid State drive or a Hard Disk Drive. The options are Hard Disk Drive and Solid State Drive.

**If the item above "Configure SATA as" is set to IDE, the following items will display:*

Serial ATA Port 0~ Port 5

This item displays the information detected on the installed SATA drive on the particular SATA port.

- Model number of drive and capacity

Port 0 ~ Port 5 SATA Device Type

Use this item to specify if the SATA port specified by the user should be connected to a Solid State drive or a Hard Disk Drive. The options are Hard Disk Drive and Solid State Drive.

**If the item above "Configure SATA as" is set to RAID, the following items will display:*

Support Aggressive Link Power Management

When this item is set to Enabled, the SATA AHCI controller manages the power usage of the SATA link. The controller will put the link to a low power state when the I/O is inactive for an extended period of time, and the power state will return to normal when the I/O becomes active. The options are **Enabled** and Disabled.

Load EFI Driver for RAID

This option enables the system to load the RAID EFI driver during system boot. Select Enabled to load the EFI driver, select **Disabled** to load the legacy driver for system boot.

Serial ATA Port 0~ Port 5

This item displays the information detected on the installed SATA drives on the particular SATA port.

- Model number of drive and capacity

Port 0 ~ Port 5 Spin Up Device

On an edge detect from 0 to 1, set this item to allow the PCH to start a COMRESET initialization to the device. The options are Enabled and **Disabled**.

Port 0 ~ Port 5 SATA Device Type

Use this item to specify if the SATA port specified by the user should be connected to a Solid State drive or a Hard Disk Drive. The options are Hard Disk Drive and Solid State Drive.

sSATA

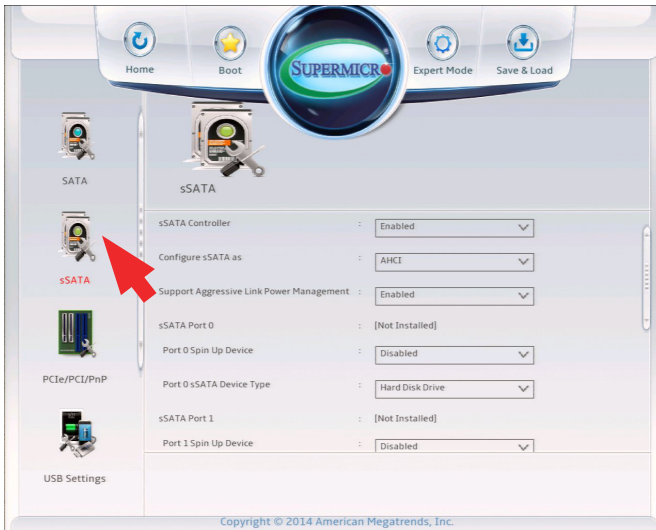

sSATA Controller

This item enables or disables the onboard SATA controller supported by the Intel PCH-sSATA controller. The options are **Enabled** and Disabled.

Configure sSATA as

Select IDE to configure an sSATA drive specified by the user as an IDE drive. Select AHCI to configure an sSATA drive specified by the user as an AHCI drive. The options are IDE, **AHCI** and RAID.

**If the item above "Configure sSATA as" is set to AHCI, the following items will display:*

Support Aggressive Link Power Management

When this item is set to Enabled, the sSATA AHCI controller manages the power usage of the sSATA link. The controller will put the link to a low power state when the I/O is inactive for an extended period of time, and the power state will return to normal when the I/O becomes active. The options are **Enabled** and Disabled.

sSATA Port 0~ Port 3

This item displays the information detected on the installed on the sSATA port. specified by the user.

- Model number of drive and capacity
- Software Preserve Support

sSATA Port 0~ Port 3

Select Enabled to enable an sSATA port specified by the user. The options are Disabled and Enabled.

sSATA Port 0 ~ Port 3 Spin Up Device

On an edge detect from 0 to 1, set this item to allow the PCH to start a COMRESET initialization to the device. The options are Enabled and **Disabled**.

Port 0 ~ Port 3 sSATA Device Type

Use this item to specify if the sSATA port specified by the user should be connected to a Solid State drive or a Hard Disk Drive. The options are Hard Disk Drive and Solid State Drive.

**If the item above "Configure sSATA as" is set to IDE, the following items will display:*

sSATA Port 0~ Port 3

This item indicates that an sSATA port specified by the user is installed (present) or not.

Port 0 ~ Port 3 sSATA Device Type (Available when a SATA port is detected)

Use this item to specify if the sSATA port specified by the user should be connected to a Solid State drive or a Hard Disk Drive. The options are Hard Disk Drive and Solid State Drive.

**If the item above "Configure sSATA as" is set to RAID, the following items will display:*

Support Aggressive Link Power Management

When this item is set to Enabled, the SATA AHCI controller manages the power usage of the SATA link. The controller will put the link to a low power state when the I/O is inactive for an extended period of time, and the power state will return to normal when the I/O becomes active. The options are **Enabled** and Disabled.

Load EFI Driver for RAID

This option enables the system to load the RAID EFI driver during system boot. Select Enabled to load the EFI driver, select **Disabled** to load the legacy driver for system boot.

Serial ATA Port 0~ Port 3

This item displays the information detected on the installed SATA drives on the particular SATA port.

- Model number of drive and capacity

Port 0 ~ Port 3 Spin Up Device

On an edge detect from 0 to 1, set this item to allow the PCH to start a COMRESET initialization to the device. The options are Enabled and **Disabled**.

Port 0 ~ Port 3 SATA Device Type

Use this item to specify if the SATA port specified by the user should be connected to a Solid State drive or a Hard Disk Drive. The options are Hard Disk Drive and Solid State Drive.

PCIe/PCI/PnP



NB PCIE Setting

CPU SLOT1 PCI-E 3.0 X8 (IN X16) - Gen X

Set this option to configure the Gen X setting of this PCIE slot . The options are **Auto**, Gen1 (2.5 GT/s), Gen2 (5 GT/s) and Gen3 (8 GT/s).

CPU Port2 Bifurcate

This option distributes PCI-E Port2 to SLOT2 and SLOT4, or SLOT4 only. The options are **Slot2 and Slot4** and Slot4.

CPU SLOT2 PCI-E 3.0 X8 (IN X16) - Gen X

Set this option to configure the Gen X setting of this PCIE slot . The options are **Auto**, Gen1 (2.5 GT/s), Gen2 (5 GT/s) and Gen3 (8 GT/s).

CPU SLOT4 PCI-E 3.0 X8 (IN X16) - Gen X

Set this option to configure the Gen X setting of this PCIE slot . The options are **Auto**, Gen1 (2.5 GT/s), Gen2 (5 GT/s) and Gen3 (8 GT/s).

CPU SLOT6 PCI-E 3.0 X16 - Gen X

Set this option to configure the Gen X setting of this PCIE slot . The options are **Auto**, Gen1 (2.5 GT/s), Gen2 (5 GT/s) and Gen3 (8 GT/s).

Detect Non-Compliant Device

Set this option to configure the motherboard to detect any non-compliant PCIE device installed on any of the PCIE slots. The options are Enabled and **Disabled**.

Above 4G Decoding (Available if the system supports 64-bit PCI decoding)

Select Enabled to decode a PCI device that supports 64-bit in the space above 4G Address. The options are Enabled and **Disabled**.

**CPU SLOT1 PCI-E 3.0 X8 (IN X16) OPROM,
CPU SLOT2 PCI-E 3.0 X8 (IN X16) OPROM,
PCH SLOT3 PCI-E 2.0 X1 (IN X4) OPROM,
CPU SLOT4 PCI-E 3.0 X8 (IN X16) OPROM,
PCH SLOT5 PCI-E 2.0 X1 (IN X4) OPROM,
CPU SLOT6 PCI-E 3.0 X16 OPROM**

Select Disabled to deactivate the selected slot, Legacy to activate the slot in legacy mode and EFI to activate the slot in EFI mode. The options are Disabled, **Legacy**, and EFI.

Onboard LAN Option ROM Type

Select an option to enable Option ROM support to boot the computer using a network device specified by the user. The options are Disabled, **Legacy** and EFI.

Onboard LAN1 Option ROM/Onboard LAN2 Option ROM

Select PXE (Preboot Execution Environment) to boot the computer using a PXE device installed in a LAN port specified. Select Disabled to prevent system boot using a device installed in a LAN port. The options for Onboard LAN1 Option ROM/ Onboard LAN2 Option ROM are **Disabled** and PXE.

Onboard Video Option ROM (X10SRA-F Only)

Select the type of Video Option ROM support. The options are Disabled, **Legacy** and EFI.

VGA Priority

Use this item to select the graphics device to be used as the primary video display for system boot. The options are **Auto** (for the X10SRA), **Onboard VGA** (for the X10SRA-F), CPU SLOT1 PCI-E 3.0 X8 (IN X16), CPU SLOT2 PCI-E 3.0 X8 (IN X16), PCH SLOT3 PCI-E 2.0 X1 (IN X4), CPU SLOT4 PCI-E 3.0 X8 (IN X16), PCH SLOT5 PCI-E 2.0 X1 (IN X4), and CPU SLOT6 PCI-E 3.0 X16.

USB Settings

The following will be displayed:

- **USB Devices** - this displays a list of the detected USB devices.

Legacy USB Support

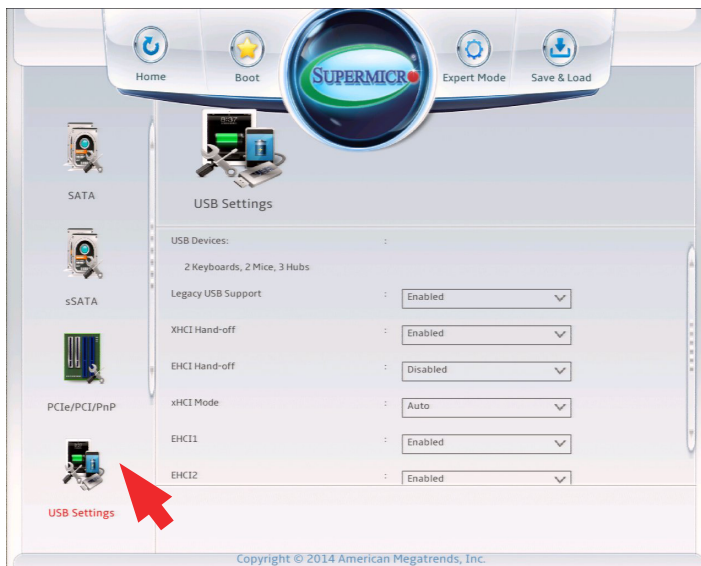

Select Enabled to support onboard legacy USB devices. Select Auto to disable legacy support if there are no legacy USB devices present. Select Disable to have all USB devices available for EFI applications only. The options are **Enabled**, Disabled and Auto.

XHCI Hand-Off

This is a work-around solution for operating systems that do not support XHCI (Extensible Host Controller Interface) hand-off. The XHCI ownership change should be claimed by the XHCI driver. The settings are **Enabled** and Disabled.

EHCI Hand-Off

This item is for operating systems that do not support Enhanced Host Controller Interface (EHCI) hand-off. When this item is enabled, EHCI ownership change will be claimed by the EHCI driver. The settings are Enabled and **Disabled**.

XHCI Mode

This feature handles the operation mode for the XHCI (Extensible Host Controller Interface) controller. The settings are **Smart Auto**, Auto, Enabled, and Disabled.

EHCI1

Select Enabled to enable EHCI (Enhanced Host Controller Interface) support on USB 2.0 connector #1 (-at least one USB 2.0 connector should be enabled for EHCI support.) The options are Disabled and **Enabled**.

EHCI2

Select Enabled to enable EHCI (Enhanced Host Controller Interface) support on USB 2.0 connector #2 (-at least one USB 2.0 connector should be enabled for EHCI support.) The options are Disabled and **Enabled**.

PCH-FW (Firmware)



The following information for the PCH Firmware.

- **ME FW Version** - displays the Management Engine version number.
- **ME Firmware Mode** - displays the Management Engine mode.
- **ME Firmware Type** - displays the Management Engine firmware type.
- **ME Firmware SKU** - displays the Management Engine SKU size.

ME FW Image Re-Flash

This item will update the PCH Firmware from an image in a USB Flashdrive attached to a USB port. The options are **Enabled** and Disabled. This feature is supported on the X10SRA only.

Super IO Configuration

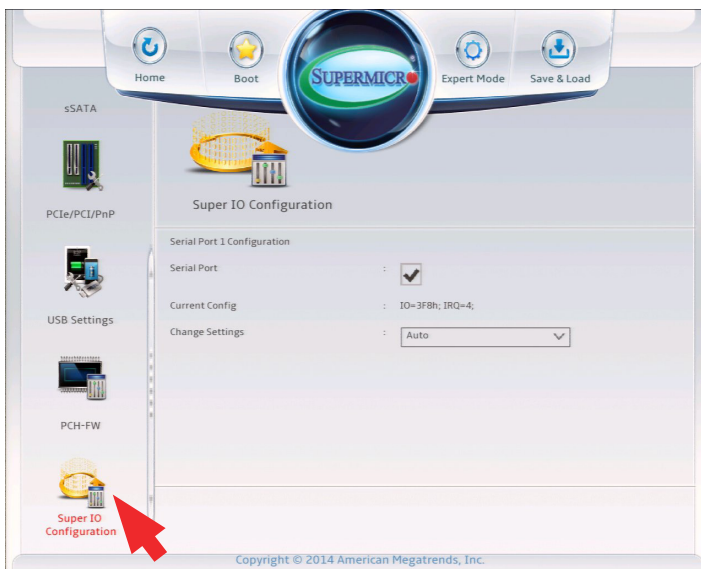

Enable Serial Port 1

This item will Enable or Disable Serial Port 1 (COM1). Place a tick mark on the box to enable Serial Port 1. The default is **Enabled**.

Current Config (IRQ)

This item displays the current IRQ setting for Serial Port 1 (COM1).

Change (IRQ) Settings

This item configures the IRQ setting for Serial Port 1 (COM1).

The options for Serial Port 1 are **Auto**, IO=3F8h; IRQ=4, IO=3F8h; IRQ=3, 4, 5, 6, 7, 9, 10, 11, 12, IO=2F8h; IRQ=3, 4, 5, 6, 7, 9, 10, 11, 12), IO=3E8h; IRQ=3, 4, 5, 6, 7, 9, 10, 11, 12 and IO=2E8h; IRQ=3, 4, 5, 6, 7, 9, 10, 11, 12.

4-9 Booting

The different boot settings and options for the motherboard are in this section.

Boot Device Settings



Boot Mode Select

Use this item to select the type of device to be used for system boot. The options are Legacy, UEFI, and **Dual**.

Fixed Boot Order Priorities

This option prioritizes the order of bootable devices from which the system will boot. Press <Enter> on each entry from top to bottom to select devices.

- Dual Boot Order #1
- Dual Boot Order #2
- Dual Boot Order #3
- Dual Boot Order #4

- Dual Boot Order #5
- Dual Boot Order #6
- Dual Boot Order #7
- Dual Boot Order #8
- Dual Boot Order #9
- Dual Boot Order #10
- Dual Boot Order #11
- Dual Boot Order #12
- Dual Boot Order #13
- Dual Boot Order #14

Network Drive BBS Priorities

- Legacy Boot Order #1, the options are **[IBA GE Slot 0500 ...]** and Disabled.

BIOS Features

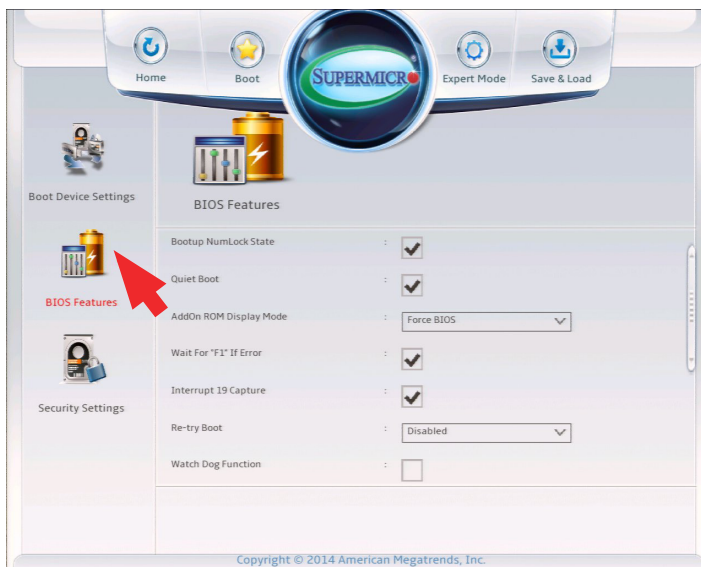

Bootup Numlock State

This option sets the state to which the NumLock key is configured when booting. The default is **checked (Activated)**.

Quiet Boot

This option sets the state to which the system buzzer is configured when booting. The default is **checked (On)**, the buzzer is silent.

AddOn ROM Display Mode

This item sets the display mode for the Option ROM. Select Keep Current to use the current AddOn ROM Display setting. Select Force BIOS to use the Option ROM display mode set by the system BIOS. The options are **Force BIOS** and **Keep Current**.

Wait for "F1" for Error

This option sets whether the system will wait for the user to press "F1" when an error is detected during POST. The default is **checked (On)**.

Interrupt 19 Capture

Interrupt 19 is the software interrupt that handles the boot disk function. When this item is set to Enabled, the ROM BIOS of the host adaptors will "capture" Interrupt 19 at bootup and allow the drives that are attached to these host adaptors to function as bootable disks. If this item is set to Disabled, the ROM BIOS of the host adap-

tors will not capture Interrupt 19, and the drives attached to these adaptors will not function as bootable devices. The options are **Enabled** and Disabled.

Retry Boot

Select Enabled to force the system to reboot when system fails to boot. The options are **Disabled** and Enabled.

Watch Dog Function

If enabled, the Watch Dog timer will allow the system to reboot when it is unresponsive for more than 5 minutes. The default is **unchecked (Off)**.

Power Button Function

This feature controls how the system shuts down when the power button is pressed. Select 4 Seconds Override for the user to power off the system after pressing and holding the power button for 4 seconds or longer. Select Instant Off to instantly power off the system as soon as the user presses the power button. The options are **Instant Off**, and 4 Seconds Override.

Restore on AC Power Loss

Use this feature to set the power state after a power outage. Select Power-Off for the system power to remain off after a power loss. Select Power-On for the system power to be turned on after a power loss. Select Last State to allow the system to resume its last power state before a power loss. The options are **Last State**, Power On, Stay Off.

CSM Support

This option enables the Compatibility Support Module (CSM) which permits the loading of a traditional OS or the use of a traditional OpROMs. The options are **Enabled** and Disabled.

EUP Support

EUP, or Energy Using Product is a European energy-saving specification that sets a standard on the maximum total power consumption on electrical products. Select Enabled to activate EUP support, select **Disabled** for normal S5 sleep mode (system wakeup capability).

Fast Boot

This option sets fast system boot, quick POST, etc . The default is **unchecked (Off)**.

Security Settings

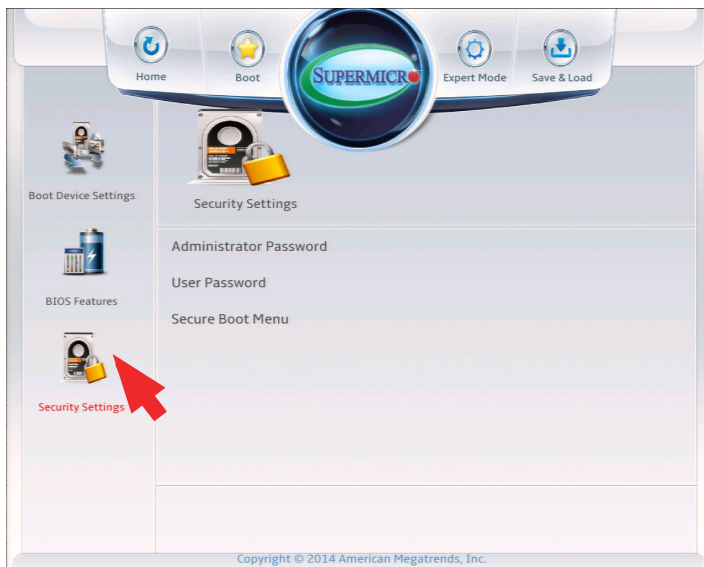

This menu allows the user to configure the following security settings for the system.

- If the Administrator password is defined ONLY - this controls access to the BIOS setup ONLY.
- If the User's password is defined ONLY - this password will need to be entered upon each system boot, and will also have Administrator rights in the setup.
- Passwords must be at least 3 and up to 20 characters long.

Administrator Password

Use this feature to set the Administrator Password which is required to enter the BIOS setup utility. The length of the password should be from 3 characters to 20 characters long.

User Password

Use this feature to set the User Password, which is required everytime the system boots. The length of the password should be from 3 characters to 20 characters long.

Secure Boot Menu

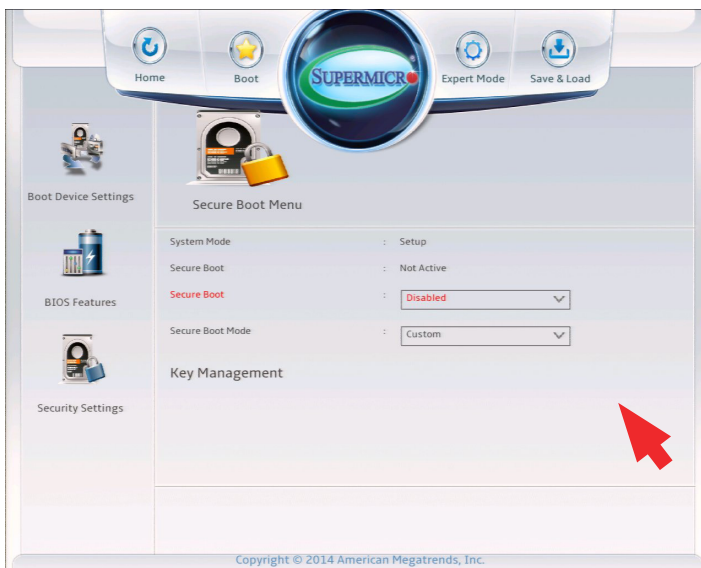

The following items will be displayed:

- **System Mode** - indicates the current system mode.
- **Secure Boot** - this item indicates if Secure Boot is activated or not.

Secure Boot

Select Enabled for Secure Boot flow control. This feature is available when the platform key (PK) is pre-registered, the platform operates in the user mode, and CSM is disabled in the Setup utility. The options are **Disabled** and Enabled.

Secure Boot Mode

This feature allows selection of the Secure Boot Mode between Standard and Custom. Selecting Custom enables users to change the Image Execution Policy and manage Secure Boot Keys. The options are **Custom** and Standard.

Key Management

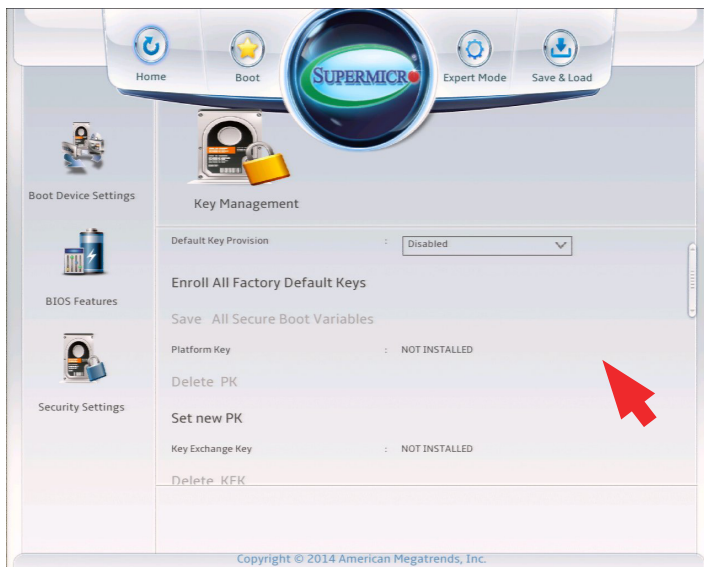

(if Secure Boot Mode is set to 'Custom')

Key Management allows experienced users to modify Secure Boot Variables.

Default Key Provision

This item will load the default key provision. The options are **Enabled** and Disabled.

Enroll All Factory Default Keys

This item will install the factory default secure variables. The options are **Yes** and No.

Save All Secure Boot Variables

This item will save all the revised secure boot variables. The options are **Yes** and No.

Platform Key

This item displays the current Platform Key status.

Delete PK

This item deletes a previously installed Platform Key.

Set New PK

This item uploads and installs a secure Platform Key. You may insert a factory default key or load from a file. The file formats accepted are: 1) Public Key Certificate

- a. EFI Signature List
 - b. EFI CERT X509 (DER Encoded)
 - c. EFI CERT RSA2048 (bin)
 - d. EFI SERT SHA256 (bin)
- 2) EFI Time Based Authenticated Variable

When prompted, select "Yes" to load Factory Defaults or "No" to load from a file.

Key Exchange Key

This item displays the current Key Exchange Key status.

Delete KEK

This item deletes a previously installed Key Exchange Key.

Set New KEK

This item uploads and installs a Key Exchange Key. You may insert a factory default key or load from a file. When prompted, select "Yes" to load Factory Defaults or "No" to load from a file.

Append KEK

This item uploads and adds a Key Exchange Key into the Key Management. You may insert a factory default key or load from a file. When prompted, select "Yes" to load Factory Defaults or "No" to load from a file.

Authorized Signatures

This item displays the current Authorized Signatures status.

Delete DBT

This item deletes a previously installed Authorized Signature.

Set New DBT

This item uploads and installs an Authorized Signature . You may insert a factory default key or load from a file. The file formats accepted are: 1) Public Key Certificate

- a. EFI Signature List
- b. EFI CERT X509 (DER Encoded)
- c. EFI CERT RSA2048 (bin)
- d. EFI SERT SHA256 (bin)

2) EFI Time Based Authenticated Variable

When prompted, select "Yes" to load Factory Defaults or "No" to load from a file.

Append DBT

This item uploads and adds an Authorized Signature into the Key Management. You may insert a factory default key or load from a file. When prompted, select "Yes" to load Factory Defaults or "No" to load from a file.

Forbidden Signatures

This item displays the current Forbidden Signatures status.

Delete DBX

This item deletes a previously installed Forbidden Signature.

Set New DBX

This item uploads and installs a Forbidden Signature . You may insert a factory default key or load from a file. The file formats accepted are: 1) Public Key Certificate

- a. EFI Signature List
- b. EFI CERT X509 (DER Encoded)
- c. EFI CERT RSA2048 (bin)
- d. EFI SERT SHA256 (bin)

2) EFI Time Based Authenticated Variable

When prompted, select "Yes" to load Factory Defaults or "No" to load from a file.

Append DBX

This item uploads and adds an Forbidden Signature into the Key Management. You may insert a factory default key or load from a file. When prompted, select "Yes" to load Factory Defaults or "No" to load from a file.

7-10 Management

Set all options for the System Management feature in this section.

ACPI Settings

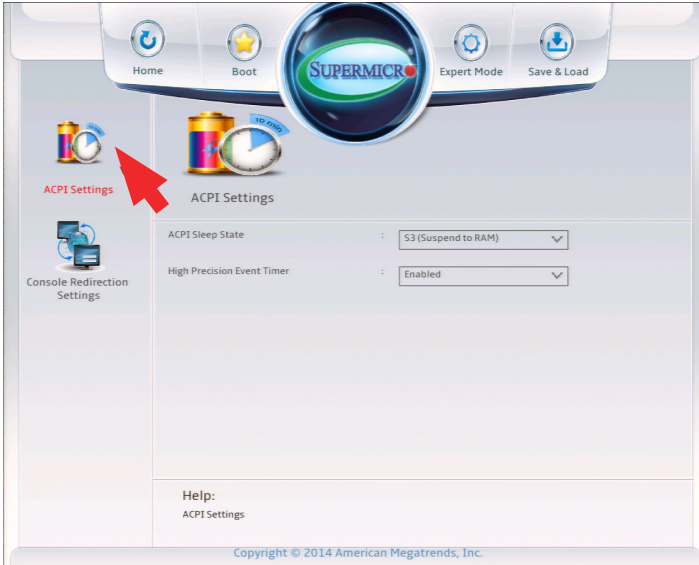

ACPI Sleep State

This feature selects the ACPI Sleep State that the system will enter into when the suspend button is activated. The options are Suspend Disabled, and **S3 (Suspend to RAM)**.

High Precision Event Timer

Select Enabled to activate the High Precision Event Timer (HPET) that produces periodic interrupts at a much higher frequency than a Real-time Clock (RTC) does in synchronizing multimedia streams, providing smooth playback and reducing the dependency on other timestamp calculation devices, such as an x86 RDTSC Instruction embedded in the CPU. The High Performance Event Timer is used to replace the 8254 Programmable Interval Timer. The options are **Enabled** and Disabled.

Console Redirection Settings

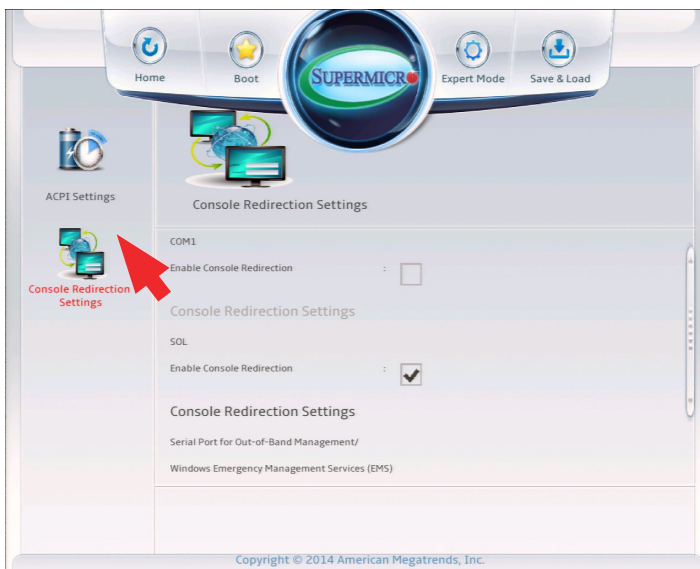

COM 1

Enable Console Redirection

Select Enabled to enable COM Port 1 Console Redirection, which will allow a client machine to be connected to a host machine at a remote site for networking. The options are **Disabled (unchecked)** and Enabled (checked).

**If the item above set to Enabled, the following items will become available for configuration:*

Console Redirection Settings

Terminal Type

This feature allows the user to select the target terminal emulation type for Console Redirection. Select VT100 to use the ASCII Character set. Select VT100+ to add color and function key support. Select ANSI to use the Extended ASCII Character Set. Select VT-UTF8 to use UTF8 encoding to map Unicode characters into one or more bytes. The options are ANSI, VT100, **VT100+**, and VT-UTF8.

Bits Per second

Use this item to set the transmission speed for a serial port used in Console Redirection. Make sure that the same speed is used in the host computer and the client computer. A lower transmission speed may be required for long and busy lines. The options are 9600, 19200, 38400, 57600 and **115200** (bits per second).

Data Bits

Use this feature to set the data transmission size for Console Redirection. The options are 7 (Bits) and **8 (Bits)**.

Parity

A parity bit can be sent along with regular data bits to detect data transmission errors. Select Even if the parity bit is set to 0, and the number of 1's in data bits is even. Select Odd if the parity bit is set to 0, and the number of 1's in data bits is odd. Select None if you do not want to send a parity bit with your data bits in transmission. Select Mark to add a mark as a parity bit to be sent along with the data bits. Select Space to add a Space as a parity bit to be sent with your data bits. The options are **None**, Even, Odd, Mark and Space.

Stop Bits

A stop bit indicates the end of a serial data packet. Select 1 Stop Bit for standard serial data communication. Select 2 Stop Bits if slower devices are used. The options are **1** and 2.

Flow Control

Use this item to set the flow control for Console Redirection to prevent data loss caused by buffer overflow. Send a "Stop" signal to stop sending data when the receiving buffer is full. Send a "Start" signal to start sending data when the receiving buffer is empty. The options are **None** and Hardware RTS/CTS.

VT-UTF8 Combo Key Support

Select Enabled to enable VT-UTF8 Combination Key support for ANSI/VT100 terminals. The options are **Enabled (checked)** and Disabled (unchecked).

Recorder Mode

Select Enabled to capture the data displayed on a terminal and send it as text messages to a remote server. The options are Enabled (checked) and **Disabled (unchecked)**.

Resolution 100x31

Select Enabled for extended-terminal resolution support. The options are **Enabled (checked)** and Disabled (unchecked).

Legacy OS Redirection Resolution

Use this item to select the number of rows and columns used in Console Redirection for legacy OS support. The options are **80x24** and 80x25.

Putty KeyPad

This feature selects Function Keys and KeyPad settings for Putty, which is a terminal emulator designed for the Windows OS. The options are **VT100**, LINUX, XTERMR6, SCO, ESCN, and VT400.

Redirection After BIOS Post

Use this feature to enable or disable legacy Console Redirection after BIOS POST. When the option-Bootloader is selected, legacy Console Redirection is disabled before booting the OS. When the option- Always Enable is selected, legacy Console Redirection remains enabled upon OS bootup. The options are **Always Enable** and Bootloader.

SOL (X10SRA-F only)

Enable Console Redirection

Select Enabled to use the SOL port for Console Redirection. The options are **Enabled (checked)** and Disabled (Unchecked).

**If the item above set to Enabled, the following items will become available for user's configuration:*

Console Redirection Settings

Terminal Type

Use this feature to select the target terminal emulation type for Console Redirection. Select VT100 to use the ASCII Character set. Select VT100+ to add color and function key support. Select ANSI to use the Extended ASCII Character Set. Select VT-UTF8 to use UTF8 encoding to map Unicode characters into one or more bytes. The options are ANSI, VT100, **VT100+**, and VT-UTF8.

Bits Per second

Use this feature to set the transmission speed for a serial port used in Console Redirection. Make sure that the same speed is used in the host computer and the client computer. A lower transmission speed may be required for long and busy lines. The options are 9600, 19200, 38400, 57600 and **115200** (bits per second).

Data Bits

Use this feature to set the data transmission size for Console Redirection. The options are 7 (Bits) and **8 (Bits)**.

Parity

A parity bit can be sent along with regular data bits to detect data transmission errors. Select Even if the parity bit is set to 0, and the number of 1's in data bits is even. Select Odd if the parity bit is set to 0, and the number of 1's in data bits

is odd. Select None if you do not want to send a parity bit with your data bits in transmission. Select Mark to add a mark as a parity bit to be sent along with the data bits. Select Space to add a Space as a parity bit to be sent with your data bits. The options are **None**, Even, Odd, Mark and Space.

Stop Bits

A stop bit indicates the end of a serial data packet. Select 1 Stop Bit for standard serial data communication. Select 2 Stop Bits if slower devices are used. The options are **1** and **2**.

Flow Control

Use this feature to set the flow control for Console Redirection to prevent data loss caused by buffer overflow. Send a "Stop" signal to stop sending data when the receiving buffer is full. Send a "Start" signal to start data-sending when the receiving buffer is empty. The options are **None** and Hardware RTS/CTS.

VT-UTF8 Combo Key Support

Select Enabled to enable VT-UTF8 Combination Key support for ANSI/VT100 terminals. The options are **Enabled (checked)** and Disabled (unchecked).

Recorder Mode

Select Enabled to capture the data displayed on a terminal and send it as text messages to a remote server. The options are **Disabled (unchecked)** and Enabled (checked).

Resolution 100x31

Select Enabled for extended-terminal resolution support. The options are Disabled (unchecked) and **Enabled (checked)**.

Legacy OS Redirection Resolution

Use this feature to select the number of rows and columns used in Console Redirection for legacy OS support. The options are **80x24** and 80x25.

Putty KeyPad

This feature selects Function Keys and KeyPad settings for Putty, which is a terminal emulator designed for the Windows OS. The options are **VT100**, LINUX, XTERMR6, SCO, ESCN, and VT400.

Redirection After BIOS Post

Use this feature to enable or disable legacy Console Redirection after BIOS POST (Power-On Self-Test). When this feature is set to Bootloader, legacy Console Redirection is disabled before booting the OS. When this feature is set

to Always Enable, legacy Console Redirection remains enabled upon OS boot. The options are **Always Enable** and Bootloader.

Serial Port for Out-of-Band Management/Windows Emergency Management Services (EMS)

The submenu allows the user to configure Console Redirection settings to support Out-of-Band Serial Port management.

Enable Console Redirection

Select Enabled to use a COM port selected by the user for EMS Console Redirection. The options are Enabled (checked) and **Disabled (unchecked)**.

**If the item above set to Enabled, the following items will become available for user's configuration:*

Console Redirection Settings

Out-of-Band Management Port

The feature selects a serial port in a client server to be used by the Windows Emergency Management Services (EMS) to communicate with a remote host server. The options are **COM1 (Console Redirection)** and SOL (Console Redirection, X10SRA-F only).

Terminal Type

Use this feature to select the target terminal emulation type for Console Redirection. Select VT100 to use the ASCII character set. Select VT100+ to add color and function key support. Select ANSI to use the extended ASCII character set. Select VT-UTF8 to use UTF8 encoding to map Unicode characters into one or more bytes. The options are ANSI, VT100, VT100+, and **VT-UTF8**.

Bits Per Second

This item sets the transmission speed for a serial port used in Console Redirection. Make sure that the same speed is used in both host computer and the client computer. A lower transmission speed may be required for long and busy lines. The options are 9600, 19200, 57600, and **115200** (bits per second).

Flow Control

Use this item to set the flow control for Console Redirection to prevent data loss caused by buffer overflow. Send a "Stop" signal to stop data-sending when the receiving buffer is full. Send a "Start" signal to start data-sending when the receiving buffer is empty. The options are **None**, Hardware RTS/CTS, and Software Xon/Xoff.

The setting for each these features is displayed:

Data Bits, Parity, Stop Bits

7-11 IPMI

Use this feature to configure Intelligent Platform Management Interface (IPMI) settings. This is supported on the X10SRA-F only.

IPMI

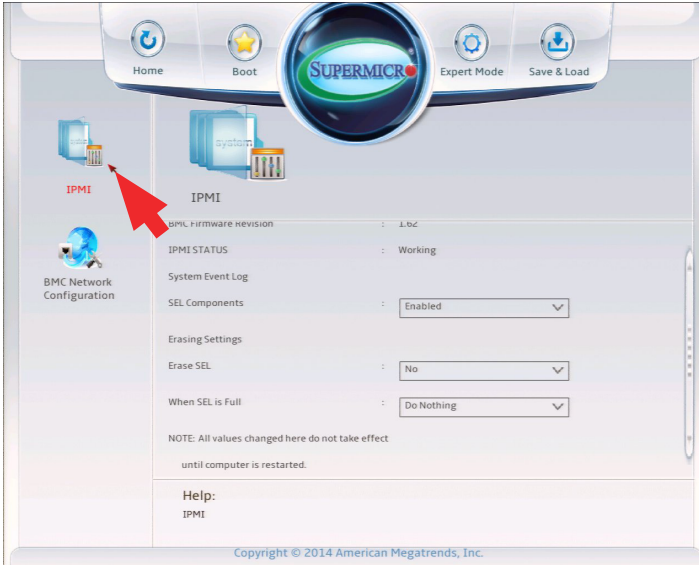

The following will be displayed:

- **IPMI Firmware Revision** - This item indicates the IPMI firmware revision used in your system.
- **IPMI Status** - This item indicates the status of the IPMI firmware installed in your system.

System Event Log

SEL Components

Select Enabled to enable all system event logging support at bootup. The options are **Enabled** and Disabled.

Erasing Settings

Erase SEL

Select **Yes, On next reset** to erase all system event logs upon next system reboot. Select **Yes, On every reset** to erase all system event logs upon each system reboot. Select **No** to keep all system event logs after each system reboot. The options are **No**, **Yes, On next reset**, and **Yes, On every reset**.

When SEL is Full

This feature allows the user to determine what the BIOS should do when the system event log is full. Select **Erase Immediately** to erase all events in the log when the system event log is full. The options are **Do Nothing** and **Erase Immediately**.

Note: After making changes on a setting, be sure to reboot the system for the changes to take effect.

BMC Network Configuration

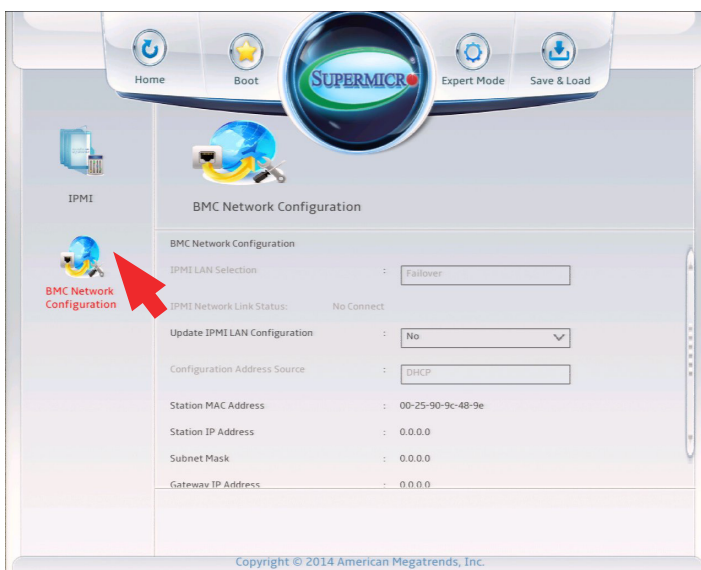

The following items will be displayed:

BMC Network Configuration

- **IPMI LAN Selection** - IPMI LAN Selection status
- **IPMI Network Link Status** - Connection status

Update IPMI LAN Configuration

Select Yes for the system BIOS to automatically reset the following IPMI settings at next system boot. The options are Yes and No.

Configuration Address Source (Available when the item above - Update IPMI LAN Configuration is set to Yes)

Use this item to select the IP address source for this computer. If Static is selected, you will need to know the IP address of this computer and enter it to the system manually in the field. If DHCP is selected, AMI BIOS will search for a DHCP (Dynamic Host Configuration Protocol) server attached to the network and request the next available IP address for this computer. The options are **DHCP** Unspecified, and Static.

Station IP Address

This item displays the Station IP address for this computer. This should be in decimal and in dotted quad form (i.e., 192.168.10.253).

Subnet Mask

This item displays the sub-network that this computer belongs to. The value of each three-digit number is separated by dots and it should not exceed 255.

Station MAC Address

This item displays the Station MAC address for this computer. Mac addresses are 6 two-digit hexadecimal numbers.

Gateway IP Address

This item displays the Gateway IP address for this computer. This should be in decimal and in dotted quad form (i.e., 192.168.10.253).

When you have completed the system configuration changes, select this option to save the changes and reboot the computer so that the new system configuration settings can take effect. Select Save Changes and Exit, and press <Enter>. When the dialog box appears, asking you if you want to exit the BIOS setup without saving, click **Yes** to quit BIOS without saving the changes, or click No to quit the BIOS and save changes.

4-12 Network Stack



Network Stack

The Network Stack is a library that is used for URL resource fetching. The options are **Disabled** and **Enabled**. If enabled, the following options will appear:

Ipv4 PXE Support (Available when Network Stack is set to Enabled)

Select **Enabled** to enable Ipv4 PXE (Preboot Execution Environment) for boot support. If this feature is set to **Disabled**, Ipv4 PXE boot option will not be supported. The options are **Enabled** and **Disabled**.

Ipv6 PXE Support (Available when Network Stack is set to Enabled)

Select **Enabled** to enable Ipv6 PXE (Preboot Execution Environment) for boot support. If this feature is set to **Disabled**, Ipv6 PXE boot option will not be supported. The options are **Enabled** and **Disabled**.

The two built-in Gb LAN ports will also appear:

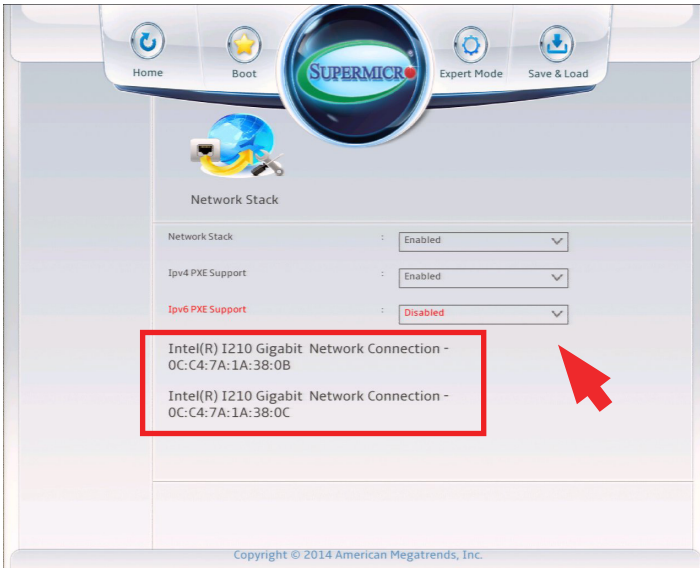

Please note that if the LAN ports do not appear as above, go back to the Main Menu and return to Network Stack to refresh the screen. These new options are clickable, and each has its own settings underneath:

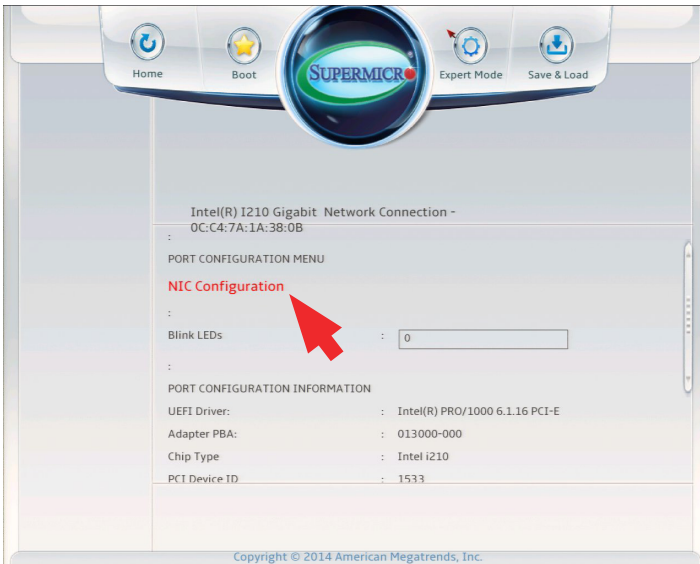

NIC Configuration

There are two link options under this link:

Link Speed

Select Auto Negotiated to allow the port to auto-configure its speed depending on the actual speed supported on the connected network. The options are **Auto Negotiated**, 10Mbps Half, 10 Mbps Full, 100 Mbps Half and 100Mbps Full.

Wake on LAN (WOL)

Select Enabled to activate this feature, which enables the system to 'wake up' from sleep when it receives a LAN wake up signal through this port. The options are **Disabled**, and Enabled.

Blink LEDs

To pin point exactly which port these settings apply to, this feature will flash the corresponding LED on the LAN port associated with these BIOS settings. Please enter a numeric value, in seconds.

Port Configuration Information

Port status and other information are displayed in this area:

UEFI Driver, Adapter PBA, Chip Type, PCI Device ID, PCI address, Link Status, MAC Address and Virtual MAC Address.

4-13 Event Logs



SMBIOS Event Log

Select Enabled to enable SMBIOS (System Management BIOS) Event Logging during system boot. The options are **Enabled** and Disabled.

Runtime Error Logging Support

Select Enabled to support Runtime Error Logging. The options are **Enabled** and Disabled. If this item is set to Enable, the following item will be available for configuration:

Memory Corrected Error Enabling (Available when the item above-Runtime Error Logging Support is set to Enable)

Select Enabled for the BIOS to correct a memory error if it is correctable. The options are **Enabled** and Disabled.

Memory Correctable Error Threshold

Use this item to enter the threshold value for correctable memory errors. The default setting is **10**.

PCI-Ex (PCI-Express) Error Enable

Select Yes for the BIOS to correct errors occurred in the PCI-E slots. The options are Yes and **No**.

Erasing Settings

Erase Event Log

Select Enabled to erase all error events in the SMBIOS (System Management BIOS) log before an event logging is initialized at bootup. The options are **No** and Yes.

When Log is Full

Select Erase Immediately to immediately erase all errors in the SMBIOS event log when the event log is full. Select Do Nothing for the system to do nothing when the SMBIOS event log is full. The options are **Do Nothing** and Erase Immediately.

SMBIOS Event Log Standard Settings

Log System Boot Event

Select Enabled to log system boot events. The options are **Disabled** and Enabled.

MECI (Multiple Event Count Increment)

Enter the increment value for the multiple event counter. Enter a number between 1 to 255. The default setting is **1**.

METW (Multiple Event Count Time Window)

This item is used to determine how long (in minutes) should the multiple event counter wait before generating a new event log. Enter a number between 0 to 99. The default setting is **60**.

Note: Please reboot the system for the changes to take effect.

Notes

Appendix A

BIOS Error Beep Codes

During the POST (Power-On Self-Test) routines, which are performed each time the system is powered on, errors may occur.

Non-fatal errors are those which, in most cases, allow the system to continue with bootup. The error messages normally appear on the screen.

Fatal errors will not allow the system to continue to bootup. If a fatal error occurs, you should consult with your system manufacturer for possible repairs.

These fatal errors are usually communicated through a series of audible beeps. The numbers on the fatal error list correspond to the number of beeps for the corresponding error.

BIOS Error Beep Codes		
Beep Code/LED	Error Message	Description
1 beep	Refresh	Circuits have been reset. (Ready to power up)
5 short beeps + 1 long beep	Memory error	No memory detected in the system
5 short beeps	Display memory read/write error	Video adapter missing or with faulty memory
OH LED On	System OH	System Overheat

Notes

Appendix B

Dual Boot Block

B-1 Introduction

This motherboard supports the Dual Boot Block feature, which is a last-ditch mechanism to recover the BIOS boot block. This section provides an introduction to the feature.

BIOS Boot Block

A BIOS boot block is the minimum BIOS loader required to enable necessary hardware components for the BIOS crisis recovery flash that will update the main BIOS block. An on-call BIOS boot-block corruption may occur due to a software tool issue (see image below) or an unexpected power outage during BIOS updates.

```
-----  
                AMI Firmware Update Utility vX.XX.XX  
                Copyright (C)XXXX American Megatrends Inc. All Rights Reserved.  
-----  
Reading flash . . . . . done  
-- ME Data Size checking . ok  
-- FFS checksums . . . . . ok  
Erasing Boot Block . . . . . done  
_ Updating Boot Block . . . . . 0x00A91000 (13%)
```

BIOS Boot Block Corruption Occurrence

When a BIOS boot block is corrupted due to an unexpected power outage or a software tool malfunctioning during BIOS updates, you can still reboot the system by activating switch JBR1 on the motherboard. When JBR1 is activated, the system will boot from a backup boot block pre-loaded in the BIOS by the manufacturer.

B-2 Steps to Reboot the System by switch JBR1

1. Power down the system.
2. On switch JBR1 slide switch to ON, and power on the system.
3. Follow the BIOS recovery SOP listed in the previous chapter (Appendix C).
4. After completing the steps above, power down the system.
5. Turn OFF switch JBR1, and power on the system.

Appendix C

System Specifications

Processors

Single Intel Xeon E5-2600/1600 v3 family or Intel Core™ i7 Series processor in an LGA2011-3 socket

Note: Please refer to our web site for a complete listing of supported processors.

Chipset

Intel C612

BIOS

128 Mb SPI AMI BIOS® SM Flash BIOS

Memory Capacity

Eight DIMM slots support up to 512GB of ECC LRDIMM, 256GB of ECC RDIMM, or 64GB of ECC/non-ECC UDIMM DDR4-2133/1866/1600/1333 memory

Note: See the memory section in Chapter 5 for details.

SATA Controller

Intel on-chip controller for 10-port SATA 3.0 (RAID supported)

Drive Bays

Eight drive bays to house four 3.5" and four 2.5" optional SATA drives

Peripheral Drive Bay

Two 5.25" drive bays

Expansion Slots

Supports the use of four standard size PCI-E 3.0 x16 expansion cards

Motherboard

X10SRA

Dimensions: 12" x 9.6" (304.8 mm x 243.84 mm)

Chassis

SC732D3-903B Form Factor: Mid-tower

Dimensions (WxHxD) 7.6 x 16.7 x 20.68 in. (193 x 424 x 525.3 mm)

Weight

Gross (Bare Bone): 39 lbs. (17.7 kg.)

System Cooling

One (1) 12-cm low-noise exhaust fan

One (1) active CPU heatsink (optional)

System Input Requirements

AC Input Voltage: 100-240 VAC

Rated Input Current: 12A - 6A

Rated Input Frequency: 50-60 Hz

Power Supply

Rated Output Power: 900W AC 80 Plus Gold Level multi output power supply
(Part# PWS-903-PQ)

Rated Output Voltages: +3.3V (25A), +5V (25A), +12V1 (25A), +12V2 (25A)
+12V3 (25A)+12V4 (25A), -12V (0.5A), +5Vsb (3A)

Power Supply Efficiency Rating: 94% (peak)

Operating Environment

Operating Temperature: 10° to 35° C (50° to 95° F)

Non-operating Temperature: -40° to 60° C (-40° to 148° F)

Operating Relative Humidity: 8% to 90% (non-condensing)

Non-operating Relative Humidity: 5 to 95% (non-condensing)

Regulatory Compliance

Electromagnetic Emissions: FCC Class B, EN 55022 Class B, EN 61000-3-2/-3-3, CISPR 22 Class B

Electromagnetic Immunity: EN 55024/CISPR 24, (EN 61000-4-2, EN 61000-4-3, EN 61000-4-4, EN 61000-4-5, EN 61000-4-6, EN 61000-4-8, EN 61000-4-11)

Safety: CSA/EN/IEC/UL 60950-1 Compliant, UL or CSA Listed (USA and Canada), CE Marking (Europe)

California Best Management Practices Regulations for Perchlorate Materials:
This Perchlorate warning applies only to products containing CR (Manganese Dioxide) Lithium coin cells. "Perchlorate Material-special handling may apply. See www.dtsc.ca.gov/hazardouswaste/perchlorate"

(continued from front)

The products sold by Supermicro are not intended for and will not be used in life support systems, medical equipment, nuclear facilities or systems, aircraft, aircraft devices, aircraft/emergency communication devices or other critical systems whose failure to perform be reasonably expected to result in significant injury or loss of life or catastrophic property damage. Accordingly, Supermicro disclaims any and all liability, and should buyer use or sell such products for use in such ultra-hazardous applications, it does so entirely at its own risk. Furthermore, buyer agrees to fully indemnify, defend and hold Supermicro harmless for and against any and all claims, demands, actions, litigation, and proceedings of any kind arising out of or related to such ultra-hazardous use or sale.