

## 407-BBRC-AO

Dell® 407-BBRC Compatible TAA 40GBase-LM4 QSFP+ Transceiver (MMF, 1270nm to 1330nm, 150m, LC, DOM)

### Features

- SFF-8436 Compliance
- Duplex LC Connector
- Commercial Temperature 0 to 70 Celsius
- Multi-mode Fiber
- Hot Pluggable
- Excellent ESD Protection
- Metal with Lower EMI
- RoHS Compliant and Lead Free



### Applications

- 40GBase Ethernet
- Access and Enterprise

### Product Description

This Dell® 407-BBRC compatible QSFP+ transceiver provides 40GBase-LX4 throughput up to 150m over multi-mode fiber (MMF) using a wavelength of 1270nm to 1330nm via an LC connector. It is guaranteed to be 100% compatible with the equivalent Dell® transceiver. This easy to install, hot swappable transceiver has been programmed, uniquely serialized and data-traffic and application tested to ensure that it will initialize and perform identically. Digital optical monitoring (DOM) support is also present to allow access to real-time operating parameters. This transceiver is Trade Agreements Act (TAA) compliant. We stand behind the quality of our products and proudly offer a limited lifetime warranty.

AddOn's transceivers are RoHS compliant and lead-free.

TAA refers to the Trade Agreements Act (19 U.S.C. & 2501-2581), which is intended to foster fair and open international trade. TAA requires that the U.S. Government may acquire only "U.S. – made or designated country end products."



## Regulatory Compliance

- ESD to the Electrical PINs: compatible with MIL-STD-883E Method 3015.4
- ESD to the LC Receptacle: compatible with IEC 61000-4-3
- EMI/EMC compatible with FCC Part 15 Subpart B Rules, EN55022:2010
- Laser Eye Safety compatible with FDA 21CFR, EN60950-1& EN (IEC) 60825-1,2
- RoHS compliant with EU RoHS 2.0 directive 2015/863/EU

## Absolute Maximum Ratings

Parameter	Symbol	Min.	Typ.	Max.	Unit
Storage Temperature	TS	-40		85	°C
Operating Temperature	Top	0		70	°C
Power Supply Voltage	Vcc	-0.5		3.6	V
Relative Humidity	Rh	0		85	%
Damage Threshold, each Lane	THd	4.5			dBm

## Recommended Operating Conditions

Parameter	Symbol	Min.	Typ.	Max.	Unit
Operating Case Temperature	TOP	0		70	°C
Power Supply Voltage	VCC	3.135	3.3	3.465	V
Data Rate, each Lane			10.3125	11.2	Gb/s
Control Input Voltage High		2		Vcc	V
Control Input Voltage Low		0		0.8	V
Link Distance (OM3 MMF)	D_MMF			150	m
Link Distance (SMF)	D_SMF			2	km

## Electrical Characteristics

Parameter	Symbol	Min.	Typ.	Max.	Unit	Notes
Power Consumption				3.5	W	
Supply Current	I <sub>cc</sub>			1.1	A	
Transceiver Power-on Initialization Time				2000	ms	1
<b>Transmitter (each lane)</b>						
Single-ended Input Voltage Tolerance (Note 2)		-0.3		4.0	V	Referred to TP1 signal common
AC Common mode Voltage Tolerance		15			mV	RMS
Differential Input Voltage Swing Threshold		50			mV <sub>pp</sub>	LOSA Threshold
Differential Input Voltage Swing	V <sub>in,pp</sub>	190		700	mV <sub>pp</sub>	
Differential Input Impedance	Z <sub>in</sub>	90	100	110	Ohm	
Differential Input Return Loss	See IEEE 802.3ba 86A.4.11				dB	10MHz-11.1GHz
J2 Jitter Tolerance	J <sub>t2</sub>	0.17			UI	
J9 Jitter Tolerance	J <sub>t9</sub>	0.29			UI	
Data Dependent Pulse Width Shrinkage	DDPWS	0.07			UI	
Eye Mask Coordinates {X1, X2, Y1, Y2}	0.11, 0.31 95, 350				UI mV	Hit Ratio = 5x10 <sup>-5</sup>
<b>Receiver (each lane)</b>						
Single-ended Output Voltage		-0.3		4.0	V	Referred to signal common
AC Common Mode Output Voltage				7.5	mV	RMS
Differential Output Voltage Swing	V <sub>out,pp</sub>	300		850	mV <sub>pp</sub>	
Differential Output Impedance	Z <sub>out</sub>	90	100	110	Ohm	
Termination Mismatch at 1MHz				5	%	
Differential Output Return Loss	See IEEE 802.3ba 86A.4.2.1				dB	10MHz-11.1GHz
Common-mode Output Return Loss	See IEEE 802.3ba 86A.4.2.2				dB	10MHz-11.1GHz
Output Transition Time		28			ps	20% to 80%
J2 Jitter Output	J <sub>o2</sub>			0.42	UI	
J9 Jitter Output	J <sub>o9</sub>			0.65	UI	
Eye Mask Coordinates {X1, X2, Y1, Y2}	0.29, 0.5 150, 425				UI mV	Hit Ratio = 5x10 <sup>-5</sup>

### Notes:

1. Power-on initialization time is the time from when the power supply voltages reach and remain above the minimum recommended operating supply voltages to the time when the module is fully functional.

- The single ended input voltage tolerance is the allowable range of the instantaneous input signals.

## Optical Characteristics

Parameter	Symbol	Min.	Typ.	Max.	Unit	Notes
Wavelength	L0	1264.5	1271	1277.5	nm	
	L1	1284.5	1291	1297.5	nm	
	L2	1304.5	1311	1317.5	nm	
	L3	1324.5	1331	1337.5	nm	
<b>Transmitter</b>						
Total Average Launch Power (for SMF)	$P_{T, SMF}$			8.3	dBm	
Total Average Launch Power (for MMF)	$P_{T, MMF}$			9.5	dBm	
Average Launch Power, each Lane (for SMF)	$P_{AVG, SMF}$	-7.0		2.3	dBm	
Average Launch Power, each Lane (for MMF)	$P_{AVG, MMF}$	-5.0		3.5	dBm	
OMA, each Lane (for SMF)	$P_{OMA, SMF}$	-6.0		3.5	dBm	1
OMA, each Lane (for MMF)	$P_{OMA, MMF}$	-4.0		4.5	dBm	
Difference in Launch Power between any Two Lanes (OMA)	$P_{tx,diff}$			6.5	dB	
Launch Power in OMA minus Transmitter and Dispersion Penalty (TDP), each Lane		-6.8			dBm	
TDP, each Lane	TDP			2.6	dB	
Extinction Ratio	ER	3.5			dB	
Relative Intensity Noise	RIN			-128	dB/Hz	12dB reflection
Transmitter Reflectance	$R_T$			-12	dB	
Transmitter Eye Mask Definition {X1, X2, X3, Y1, Y2, Y3}	{0.23, 0.34, 0.43, 0.27, 0.35, 0.4}					
Average Launch Power OFF Transmitter, each Lane	$P_{off}$			-30	dBm	
<b>Receiver</b>						
Damage Threshold, each Lane	$TH_d$	4.5			dBm	2
Total Average Receive Power (for SMF)				8.3	dBm	
Total Average Receive Power (for MMF)				9.5	dBm	
Average Receive Power, each Lane (for SMF)		-11.7		2.3	dBm	
Average Receive Power, each Lane (for MMF)		-7.0		3.5	dBm	
Receiver Reflectance	$R_R$			-26	dB	

Receive Power (OMA), each Lane (for SMF)				3.5	dBm	
Receive Power (OMA), each Lane (for MMF)				4.5	dBm	
Receiver Sensitivity (OMA), each Lane (for SMF)	SEN <sub>SMF</sub>			-11.5	dBm	
Receiver Sensitivity (OMA), each Lane (for MMF)	SEN <sub>MMF</sub>			-10.5	dBm	
Difference in Receive Power between any Two Lanes (OMA)	Prx,diff			7.5	dB	
LOS Assert	LOSA	-28			dBm	
LOS Deassert	LOSD			-15	dBm	
LOS Hysteresis	LOSH	0.5			dB	
Receiver Electrical 3 dB upper Cutoff Frequency, each Lane	Fc			12.3	GHz	

**Notes:**

1. Even if the TDP < 0.8 dB, the OMA min must exceed the minimum value specified here.
2. The receiver shall be able to tolerate, without damage, continuous exposure to a modulated optical input signal having this power level on one lane. The receiver does not have to operate correctly at this input power.

**Electrical Pin-out Details**

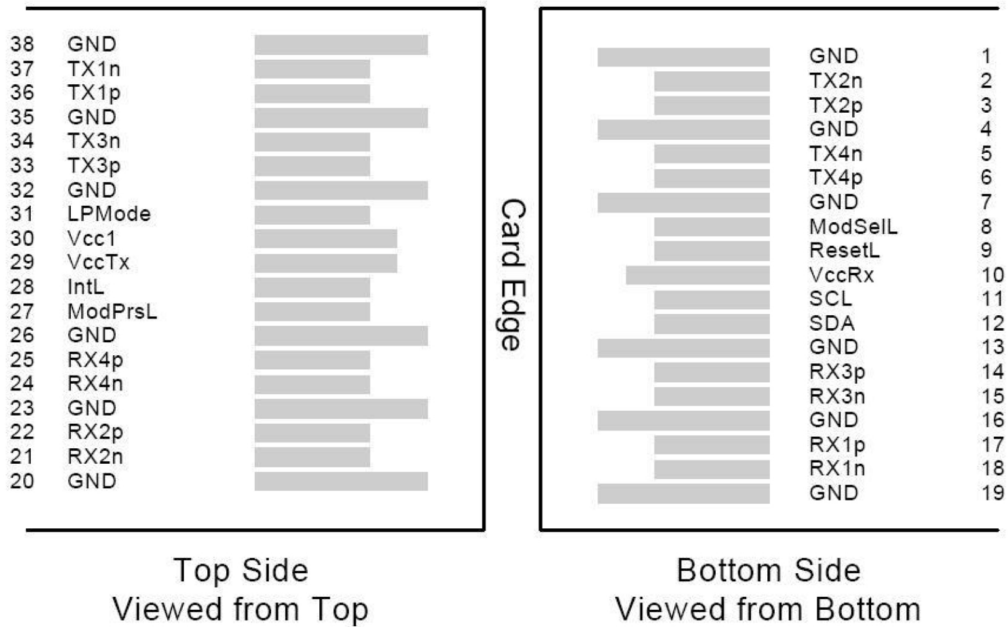

## Pin Descriptions

Pin	Logic	Symbol	Name/Descriptions	Ref.
1		GND	Module Ground	1
2	CML-I	Tx2-	Transmitter inverted data input	
3	CML-I	Tx2+	Transmitter non-inverted data input	
4		GND	Module Ground	1
5	CML-I	Tx4-	Transmitter inverted data input	
6	CML-I	Tx4+	Transmitter non-inverted data input	
7		GND	Module Ground	1
8	LVTTTL-I	MODSEIL	Module Select	2
9	LVTTTL-I	ResetL	Module Reset	2
10		VCCRx	+3.3v Receiver Power Supply	
11	LVC MOS-I	SCL	2-wire Serial interface clock	2
12	LVC MOS-I/O	SDA	2-wire Serial interface data	2
13		GND	Module Ground	1
14	CML-O	RX3+	Receiver non-inverted data output	
15	CML-O	RX3-	Receiver inverted data output	
16		GND	Module Ground	1
17	CML-O	RX1+	Receiver non-inverted data output	
18	CML-O	RX1-	Receiver inverted data output	
19		GND	Module Ground	1
20		GND	Module Ground	1
21	CML-O	RX2-	Receiver inverted data output	
22	CML-O	RX2+	Receiver non-inverted data output	
23		GND	Module Ground	1
24	CML-O	RX4-	Receiver inverted data output	
25	CML-O	RX4+	Receiver non-inverted data output	
26		GND	Module Ground	1
27	LVTTTL-O	ModPrsL	Module Present, internal pulled down to GND	
28	LVTTTL-O	IntL	Interrupt output should be pulled up on host board	2
29		VCCTx	+3.3v Transmitter Power Supply	
30		VCC1	+3.3v Power Supply	
31	LVTTTL-I	LPMode	Low Power Mode	2
32		GND	Module Ground	1
33	CML-I	Tx3+	Transmitter non-inverted data input	
34	CML-I	Tx3-	Transmitter inverted data input	
35		GND	Module Ground	1
36	CML-I	Tx1+	Transmitter non-inverted data input	
37	CML-I	Tx1-	Transmitter inverted data input	
38		GND	Module Ground	1

**Notes:**

- 1. Module circuit ground is isolated from module chassis ground with in the module.
- 2. Open collector; should be pulled up with 4.7k-10k ohms on host board to a voltage between 3.15V and 3.6V.

**Recommended Power Supply Filter**

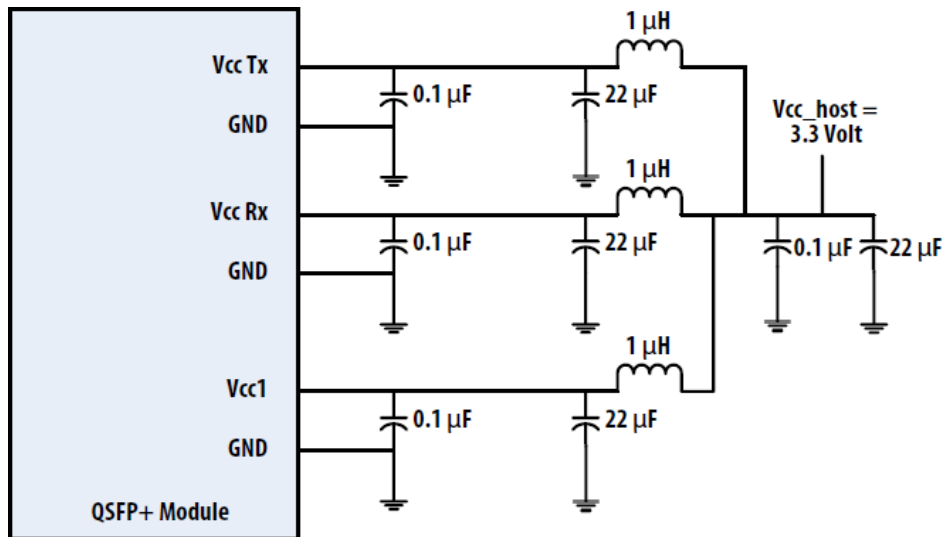

**Mechanical Specifications**

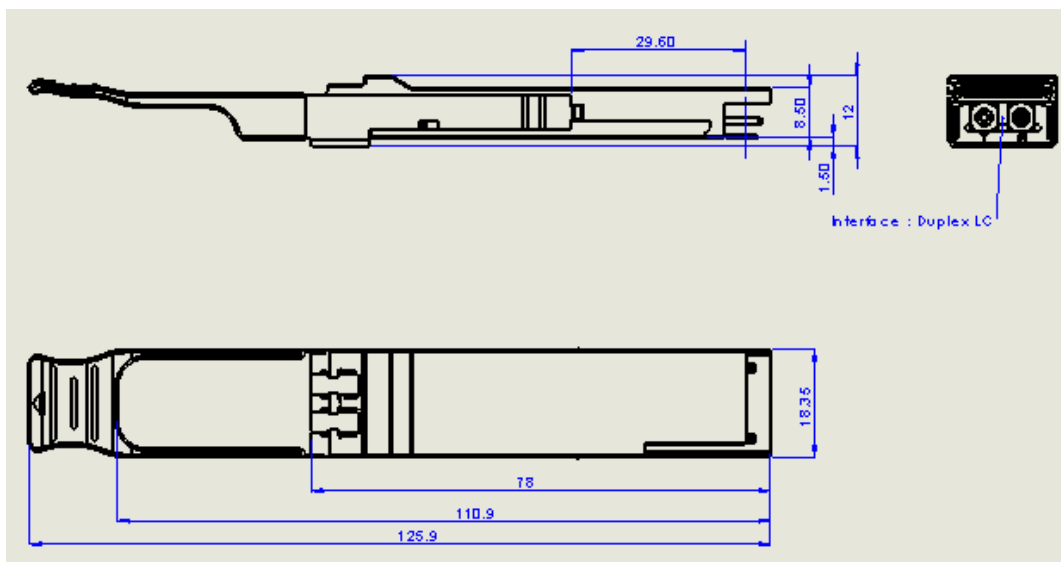

## **About AddOn Networks**

In 1999, AddOn Networks entered the market with a single product. Our founders fulfilled a severe shortage for compatible, cost-effective optical transceivers that compete at the same performance levels as leading OEM manufacturers. Adhering to the idea of redefining service and product quality not previously had in the fiber optic networking industry, AddOn invested resources in solution design, production, fulfillment, and global support.

Combining one of the most extensive and stringent testing processes in the industry, an exceptional free tech support center, and a consistent roll-out of innovative technologies, AddOn has continually set industry standards of quality and reliability throughout its history.

Reliability is the cornerstone of any optical fiber network and is engrained in AddOn's DNA. It has played a key role in nurturing the long-term relationships developed over the years with customers. AddOn remains committed to exceeding industry standards with certifications from ranging from NEBS Level 3 to ISO 9001:2005 with every new development while maintaining the signature reliability of its products.

## **U.S. Headquarters**

Email: [sales@addonnetworks.com](mailto:sales@addonnetworks.com)

Telephone: +1 877.292.1701

Fax: 949.266.9273

## **Europe Headquarters**

Email: [salesupportemea@addonnetworks.com](mailto:salesupportemea@addonnetworks.com)

Telephone: +44 1285 842070