

SUPER[®]

SUPERSERVER[®]

1028GQ-TR
1028GQ-TRT

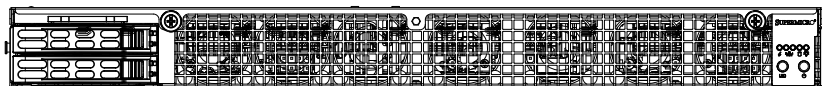

USER'S MANUAL

Revision 1.0

The information in this User's Manual has been carefully reviewed and is believed to be accurate. The vendor assumes no responsibility for any inaccuracies that may be contained in this document, makes no commitment to update or to keep current the information in this manual, or to notify any person or organization of the updates. **Please Note: For the most up-to-date version of this manual, please see our web site at www.supermicro.com.**

Super Micro Computer, Inc. ("Supermicro") reserves the right to make changes to the product described in this manual at any time and without notice. This product, including software and documentation, is the property of Supermicro and/or its licensors, and is supplied only under a license. Any use or reproduction of this product is not allowed, except as expressly permitted by the terms of said license.

IN NO EVENT WILL SUPERMICRO BE LIABLE FOR DIRECT, INDIRECT, SPECIAL, INCIDENTAL, SPECULATIVE OR CONSEQUENTIAL DAMAGES ARISING FROM THE USE OR INABILITY TO USE THIS PRODUCT OR DOCUMENTATION, EVEN IF ADVISED OF THE POSSIBILITY OF SUCH DAMAGES. IN PARTICULAR, SUPERMICRO SHALL NOT HAVE LIABILITY FOR ANY HARDWARE, SOFTWARE, OR DATA STORED OR USED WITH THE PRODUCT, INCLUDING THE COSTS OF REPAIRING, REPLACING, INTEGRATING, INSTALLING OR RECOVERING SUCH HARDWARE, SOFTWARE, OR DATA.

Any disputes arising between manufacturer and customer shall be governed by the laws of Santa Clara County in the State of California, USA. The State of California, County of Santa Clara shall be the exclusive venue for the resolution of any such disputes. Super Micro's total liability for all claims will not exceed the price paid for the hardware product.

FCC Statement: This equipment has been tested and found to comply with the limits for a Class A digital device pursuant to Part 15 of the FCC Rules. These limits are designed to provide reasonable protection against harmful interference when the equipment is operated in a commercial environment. This equipment generates, uses, and can radiate radio frequency energy and, if not installed and used in accordance with the manufacturer's instruction manual, may cause harmful interference with radio communications. Operation of this equipment in a residential area is likely to cause harmful interference, in which case you will be required to correct the interference at your own expense.

California Best Management Practices Regulations for Perchlorate Materials: This Perchlorate warning applies only to products containing CR (Manganese Dioxide) Lithium coin cells. "Perchlorate Material-special handling may apply. See www.dtsc.ca.gov/hazardouswaste/perchlorate"

WARNING: Handling of lead solder materials used in this product may expose you to lead, a chemical known to the State of California to cause birth defects and other reproductive harm.

Manual Revision 1.0

Release Date: September 30, 2015

mk

Unless you request and receive written permission from Super Micro Computer, Inc., you may not copy any part of this document.

Information in this document is subject to change without notice. Other products and companies referred to herein are trademarks or registered trademarks of their respective companies or mark holders.

Copyright © 2015 by Super Micro Computer, Inc.
All rights reserved.

Printed in the United States of America

Preface

About this Manual

This manual is written for professional system integrators and PC technicians. It provides information for the installation and use of the SuperServer 1028GQ-TR(T). Installation and maintenance should be performed by experienced technicians only.

Please refer to the server specifications page on our Web site for updates on supported memory, processors and operating systems (<http://www.supermicro.com>).

Notes

For your system to work properly, please follow the links below to download all necessary drivers/utilities and the user's manual for your server.

- Supermicro product manuals: <http://www.supermicro.com/support/manuals/>
- Product drivers and utilities: <ftp://ftp.supermicro.com>
- Product safety info:
http://www.supermicro.com/about/policies/safety_information.cfm

If you have any questions, please contact our support team at:
support@supermicro.com

This manual may be periodically updated without notice. Please check the Supermicro Web site for possible updates to the manual revision level.

Warnings

Special attention should be given to the following symbols used in this manual.



Warning! Indicates important information given to prevent equipment/property damage or personal injury.



Warning! Indicates high voltage may be encountered when performing a procedure.

Contents

Chapter 1 Introduction	1-1
1-1 Overview	1-1
1-2 Motherboard Features	1-2
Processors	1-2
Memory	1-2
Onboard Serial ATA	1-2
Input/Output Ports	1-2
Graphics Controller	1-2
1-3 Chassis Features	1-4
System Power	1-4
Hard Drives	1-4
GPU and PCI Expansion Slots	1-4
Front Control Panel	1-4
Cooling System	1-4
1-4 Contacting Supermicro	1-5
Chapter 2 Server Installation	
2-1 Overview	2-1
2-2 Unpacking the System	2-1
2-3 Preparing for Setup	2-1
Choosing a Setup Location	2-1
2-4 Warnings and Precautions	2-2
Rack Precautions	2-2
Server Precautions	2-2
Rack Mounting Considerations	2-3
Ambient Operating Temperature	2-3
Reduced Airflow	2-3
Mechanical Loading	2-3
Circuit Overloading	2-3
Reliable Ground	2-3
2-5 Installing the System into a Rack	2-4
Identifying the Sections of the Rack Rails	2-4
Installing the Optional Inner Rail Extensions	2-5
Assembling the Outer Rails	2-6
Installing the Outer Rails onto the Rack	2-7
Installing and Removing the Chassis From a Rack	2-8

Chapter 3 System Interface	3-1
3-1 Overview	3-1
3-2 Control Panel Buttons	3-2
Power	3-2
Unit Identification.....	3-2
3-3 Control Panel LEDs	3-2
NIC2 and NIC1.....	3-2
Overheating.....	3-4
Overheat Temperature Setting	3-4
Responses.....	3-4
3-4 Drive Carrier LEDs.....	3-4
3-5 Power Supply LEDs	3-5
Chapter 4 Standardized Warning Statements for AC Systems	
About Standardized Warning Statements.....	4-1
Warning Definition	4-1
Installation Instructions.....	4-4
Circuit Breaker	4-5
Power Disconnection Warning	4-6
Equipment Installation.....	4-8
Restricted Area.....	4-9
Battery Handling.....	4-10
Redundant Power Supplies (if applicable to your system).....	4-12
Backplane Voltage (if applicable to your system).....	4-13
Comply with Local and National Electrical Codes	4-14
Product Disposal	4-15
Hot Swap Fan Warning (if applicable to your system)	4-16
Power Cable and AC Adapter	4-18
Chapter 5 Advanced Motherboard Setup	
5-1 Handling the Motherboard	5-1
Precautions	5-1
Unpacking	5-1
5-2 Installing the Processor and Heatsink	5-2
Installing an LGA 2011 Processor.....	5-2
Installing a CPU Heatsink	5-5
Removing the Heatsink	5-6
5-3 Connecting Cables.....	5-7
Connecting Data Cables.....	5-7
Connecting Power Cables	5-7
Connecting the Control Panel.....	5-7

5-4	Input/Output Ports	5-8
	LAN Ports	5-8
5-5	Installing Memory	5-9
	Memory Support	5-10
	Processor and Memory Module Population Configuration	5-10
	Populating RDIM/LRDIMM DDR4 ECC Memory Modules	5-11
5-6	Motherboard Details	5-12
	Motherboard Quick Reference	5-13
5-7	Connector Definitions	5-14
	Power Connectors	5-14
	Control Panel Connector	5-14
	Other Connectors	5-17
5-8	Jumper Settings	5-20
5-9	Onboard Indicators	5-22
5-10	SATA Ports	5-23
5-11	Installing Software	5-24
	SuperDoctor® 5	5-25
5-12	Onboard Battery	5-26
	Chapter 6 Advanced Chassis Setup.....	6-1
6-1	Static-Sensitive Devices	6-2
	Precautions	6-2
6-2	Removing Power	6-2
6-3	Removing the Chassis Cover	6-3
6-4	Control Panel	6-4
6-5	Hard Drive Installation	6-4
	Externally Accessable Drives	6-5
	Internal Drives	6-8
6-6	Adding Expansion Cards	6-9
	Graphic Processor Units	6-9
	PCI	6-12
6-7	Cooling	6-13
	System Fans	6-13
	Air Shroud and Block	6-14
6-8	Power Supply	6-15
	Replacing a Power Supply Module	6-15

Chapter 7 BIOS

7-1	Introduction.....	7-1
	Starting BIOS Setup Utility.....	7-1
	How To Change the Configuration Data	7-1
	Starting the Setup Utility	7-2
7-2	Main Setup.....	7-2
7-3	Advanced Setup Configurations.....	7-4
7-4	Event Logs	7-38
7-5	IPMI.....	7-40
7-6	Security	7-43
7-7	Boot.....	7-47
7-8	Save & Exit.....	7-49
	Appendix A BIOS Error Beep Codes	A-1
	Appendix B System Specifications	B-1

Notes

Chapter 1

Introduction

1-1 Overview

The SuperServer 1028GQ-TR(T) is a high-end GPU server comprised of two main subsystems: the SC118GQE-R2K03P 1U server chassis and the X10DGQ dual processor motherboard. It supports up to four GPUs, either active or passive. Refer to the Supermicro web site for information on operating systems that have been certified for use with the system (www.supermicro.com).

1028GQ-TR(T) Models		
System	LAN Ports	Add-on Module
1028GQ-TR	Two 1Gbit	AOM-PIO-I2G
1028GQ-TRT	Two 10Gbit	AOM-PIO-I2XT-P

In addition to the above components, the server includes:

- Add-on Module (AOM-PIO-I2G or AOM-PIO-I2XT-P)
- SAS3 backplane supporting two drives (BPN-SAS3-118GQE)
- Nine 4-cm system cooling fans (FAN-0163L4)
- Two passive CPU heatsinks (SNK-P0057P)
- Air shroud set (MCP-310-11805)
- Riser Cards:
 - Three for front GPU (RSC-G-6)
 - One for rear GPU (RSC-GR-6)
 - One for low-profile add-on card (RSC-GR-A88)

Note: For your system to work properly, please follow the links below to download all necessary drivers/utilities and the user's manual for your server.

- Supermicro product manuals: <http://www.supermicro.com/support/manuals/>
- Product drivers and utilities: <ftp://ftp.supermicro.com>
- Product safety info: http://www.supermicro.com/about/policies/safety_information.cfm

For support, email support@supermicro.com.

1-2 Motherboard Features

At the heart of the SuperServer 1028GQ-TR(T) lies the X10DGQ, a dual processor motherboard based on the Intel PCH C612 chipset. Below are the main features of the motherboard. (See Figure 1-1 for a block diagram of the chipset.)

Processors

The motherboard supports single or dual Intel E5-2600 v3 Series processors in LGA2011 sockets (Socket R3). Refer to the Supermicro web site for a complete listing of supported processors (www.supermicro.com).

Memory

The motherboard has 16 sockets that can support up to 1 TB of LRDIMM (Load-Reduced DIMMs) or 512 GB of RDIMM (Registered DIMMs). Memory type is ECC DDR4 SRAM, 2133/1866/1600 MHz.

Onboard Serial ATA

The motherboard has six SATA 3.0 connections from Intel PCH (SATA1-6) with two SATA ports used for SuperDOMs (Device-on-Module) with power supply built in. RAID 0, 1, 5 and 10 are supported by Intel PCH.

Input/Output Ports

The rear I/O ports include two USB 3.0 ports, a dedicated IPMI LAN port, and two LAN ports. The 1028GQ-TR model offers two Gigabit LAN ports; the 1028GQ-TRT model features two 10-Gigabit LAN ports. These are all presented on the chassis rear by means of the add-on module.

A VGA port is also available on the chassis rear.

Also available on the motherboard are one COM header and a header for two USB 2.0 ports.

Graphics Controller

The motherboard features an integrated ASpeed AST2400 BMC graphics chip.

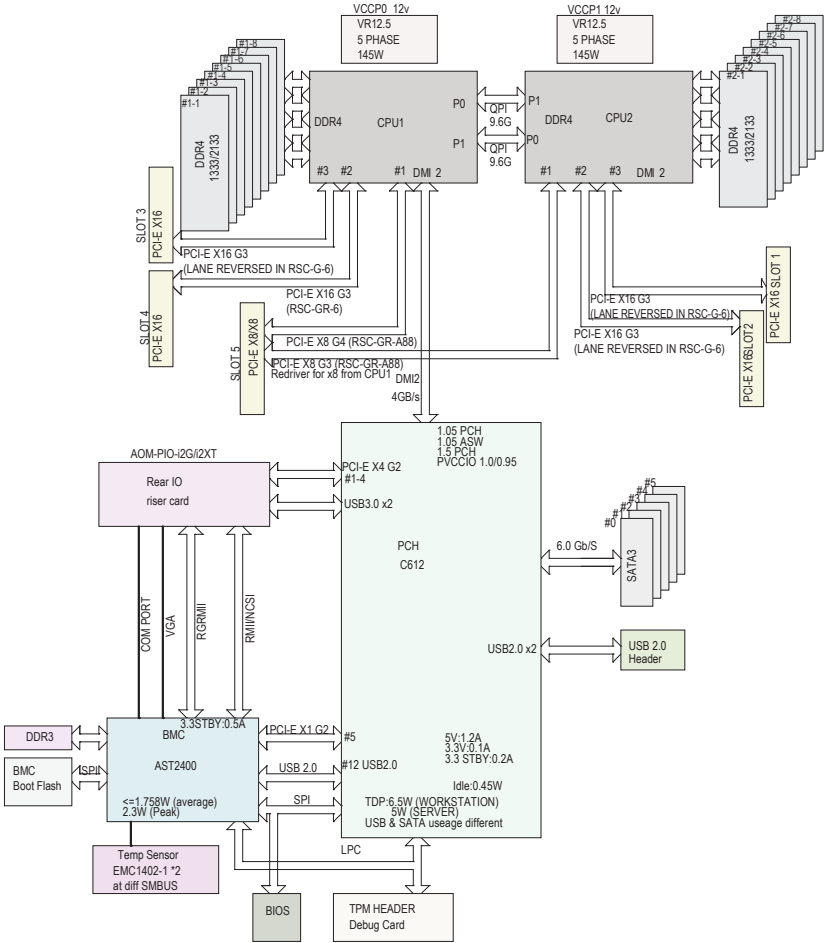

**Figure 1-1. Intel C612 Chipset:
System Block Diagram**

Note: This is a general block diagram. Please see Chapter 5 for details.

1-3 Chassis Features

The 1028GQ-TR(T) is built upon the SC118GQE-R2K03P chassis. The following are the main features.

System Power

The chassis features a redundant 2 KW power supply consisting of two hot-plug power modules. They have 80 Plus certification at Platinum Level (94%) high-efficiency. The system will continue to operate if one module fails or is replaced.

Hard Drives

The chassis supports two 2.5" hot-swap hard drives and two internal fixed 2.5" hard drives.

GPU and PCI Expansion Slots

The system offers four PCI-E 3.0 x16 slots that support optional graphics processing units (GPUs)/Xeon Phi cards, plus two low profile PCI-E 3.0 x8 slots.

The system supports graphics processing units K1/K2/K40M/K80/Xeon Phi.

Front Control Panel

The chassis front control panel provides system monitoring and power control. Status LEDs indicate system power, HDD activity, network activity, UID, and overheat and fan failure.

Cooling System

The chassis has nine 4-cm heavy duty, counter-rotating fans, plus an air shroud to direct air. Fan speed can be controlled by system temperature using IPMI. Each power supply module also includes a cooling fan.

1-4 Contacting Supermicro

Headquarters

Address: Super Micro Computer, Inc.
980 Rock Ave.
San Jose, CA 95131 U.S.A.

Tel: +1 (408) 503-8000

Fax: +1 (408) 503-8008

Email: marketing@supermicro.com (General Information)
support@supermicro.com (Technical Support)

Web Site: www.supermicro.com

Europe

Address: Super Micro Computer B.V.
Het Sterrenbeeld 28, 5215 ML
's-Hertogenbosch, The Netherlands

Tel: +31 (0) 73-6400390

Fax: +31 (0) 73-6416525

Email: sales@supermicro.nl (General Information)
support@supermicro.nl (Technical Support)
rma@supermicro.nl (Customer Support)

Web Site: www.supermicro.nl

Asia-Pacific

Address: Super Micro Computer, Inc.
3F, No. 150, Jian 1st Rd.
Zhonghe Dist., New Taipei City 235
Taiwan (R.O.C)

Tel: +886-(2) 8226-3990

Fax: +886-(2) 8226-3992

Email: support@supermicro.com.tw

Web Site: www.supermicro.com.tw

Notes

Chapter 2

Server Installation

2-1 Overview

This chapter provides a quick setup checklist to get your system up and running. This quick setup assumes that your system has come to you with the processors and memory preinstalled. If your system is not already fully integrated with a serverboard, processors, system memory etc., please turn to the chapter or section noted in each step for details on installing specific components.

2-2 Unpacking the System

You should inspect the box the chassis was shipped in and note if it was damaged in any way. If the chassis itself shows damage, file a damage claim with the carrier who delivered it.

2-3 Preparing for Setup

Decide on a suitable location for the rack unit that will hold your chassis. It should be a clean, dust-free area that is well ventilated. Avoid areas where heat, electrical noise and electromagnetic fields are generated. A nearby grounded power outlet is required.

The box your chassis was shipped in should include two sets of rail assemblies, two rail mounting brackets and the mounting screws to mount the system into the rack. Please read this chapter in its entirety before beginning the installation procedure.

Choosing a Setup Location

- Leave enough clearance in front of the rack to enable you to open the front door completely (~25 inches) and approximately 30 inches of clearance in the back of the rack to allow for sufficient airflow and ease in servicing. This product is for installation only in a Restricted Access Location (dedicated equipment rooms, service closets and the like).
- This product is not suitable for use with visual display work place devices according to §2 of the the German Ordinance for Work with Visual Display Units.

2-4 Warnings and Precautions

Rack Precautions

- Ensure that the leveling jacks on the bottom of the rack are fully extended to the floor with the full weight of the rack resting on them.
- In single rack installation, stabilizers should be attached to the rack. In multiple rack installations, the racks should be coupled together.
- Always make sure the rack is stable before extending a component from the rack.
- You should extend only one component at a time - extending two or more simultaneously may cause the rack to become unstable.
- Rack-mounted equipment should not be used as a shelf or work space.

Server Precautions

- Review the electrical and general safety precautions in Chapter 4.
- Determine the placement of each component in the rack *before* you install the rails.
- Install the heaviest server components on the bottom of the rack first, and then work up.
- Use a regulating uninterruptible power supply (UPS) to protect the server from power surges, voltage spikes and to keep your system operating in case of a power failure.
- Allow the hot plug SATA drives and power supply modules to cool before touching them.
- Always keep the rack's front door and all panels and components on the servers closed when not servicing to maintain proper cooling.

Rack Mounting Considerations

Ambient Operating Temperature

If installed in a closed or multi-unit rack assembly, the ambient operating temperature of the rack environment may be greater than the ambient temperature of the room. Therefore, consideration should be given to installing the equipment in an environment compatible with the manufacturer's maximum rated ambient temperature (T_{mra}).

Reduced Airflow

Equipment should be mounted into a rack so that the amount of airflow required for safe operation is not compromised.

Mechanical Loading

Equipment should be mounted into a rack so that a hazardous condition does not arise due to uneven mechanical loading.

Circuit Overloading

Consideration should be given to the connection of the equipment to the power supply circuitry and the effect that any possible overloading of circuits might have on overcurrent protection and power supply wiring. Appropriate consideration of the equipment nameplate ratings should be used when addressing this concern.

Reliable Ground

A reliable ground must be maintained at all times. To ensure this, the rack itself should be grounded. Particular attention should be given to power supply connections other than the direct connections to the branch circuit (i.e. the use of power strips, etc.).



Warning! To prevent bodily injury when mounting or servicing this unit in a rack, you must take special precautions to ensure that the system remains stable. The following guidelines are provided to ensure your safety:

- This unit should be mounted at the bottom of the rack if it is the only unit in the rack.
- When mounting this unit in a partially filled rack, load the rack from the bottom to the top with the heaviest component at the bottom of the rack.
- If the rack is provided with stabilizing devices, install the stabilizers before mounting or servicing the unit in the rack.
- Slide rail mounted equipment is not to be used as a shelf or a work space.

2-5 Installing the System into a Rack

There are a variety of rack units on the market, which may require a slightly different assembly procedure. This rail set fits a rack between 25.6" and 33" deep.

The following is a basic guideline for installing the system into a rack with the rack mounting hardware provided. You should also refer to the installation instructions that came with the specific rack you are using.

Identifying the Sections of the Rails

The chassis comes with two sets of rack rails, one set for the right side of the chassis and one for the left. Each set consists of an inner rail that is pre-attached to the chassis, and an outer rail that attaches to the rack.

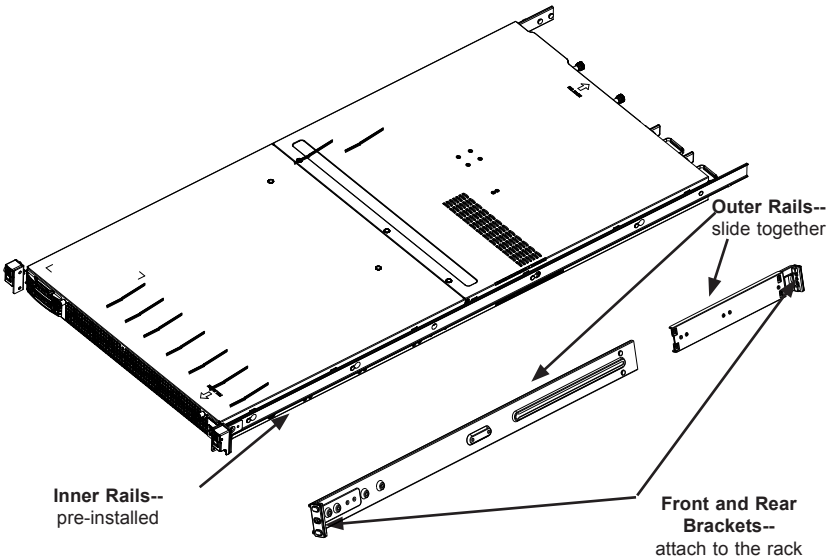

Figure 2-1. Identifying the Sections of the Rack Rails

Assembling the Outer Rails

Each outer rail comes in two sections that must be assembled before mounting onto the rack.

Assembling the Outer Rails

1. Identify the left and right outer rails by examining the ends, which bend outward. Match the left front outer rail with the left rear outer rail and the same for the right rails.
2. Align the round post in the rear rail (B) with the round hole at the end of the slot in the front rail (A), and slide the front section into the rear section.

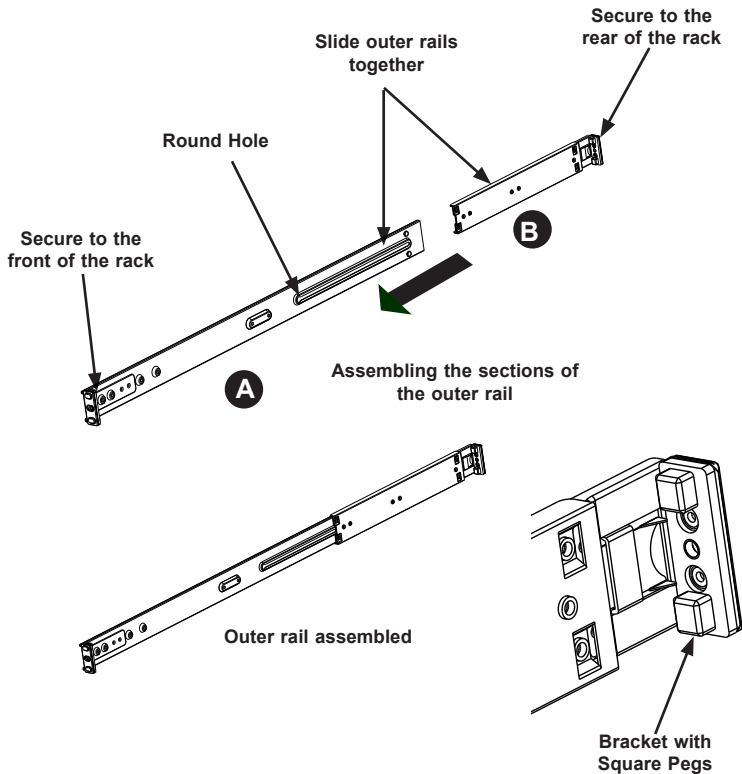

Figure 5-3. Assembling the Outer Rails

Installing the Outer Rails onto the Rack

Each end of the assembled outer rail includes a bracket with square pegs to fit into your rack holes. If you have an older rack with round holes, these brackets must be removed, and you must use screws to secure the rail to the rack.

Outer Rail Installation

1. Align the square pegs on the front end of the rail with the square holes on the front of the rack (C). Push the rail into the rack until the quick release bracket snaps into place, securing the rail to the rack. Keep the rail horizontal.
2. Adjust the rail to reach just past the full depth of your rack.
3. Align the square pegs on the rear end of the rail to the holes on the rack (D) and push the rail into the rack until the quick release bracket snaps into place, securing the rail to the rack.

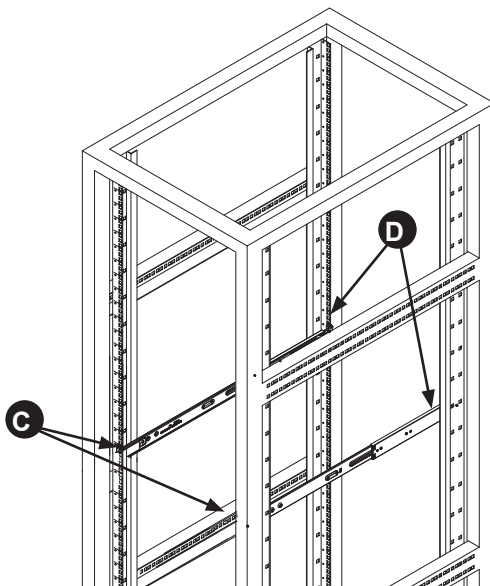

Figure 2-4. Installing the Outer Rails to the Rack

Note: The figure above is for illustrative purposes only. Always install servers at the bottom of the rack first.



Stability hazard. The rack stabilizing mechanism must be in place, or the rack must be bolted to the floor before you slide the unit out for servicing. Failure to stabilize the rack can cause the rack to tip over.

Installing and Removing the Chassis From a Rack

Installing the Chassis into a Rack

1. Align the rear of the chassis rails with the front of the rack rails and then push evenly on both sides of the chassis. The spring latch engages when the chassis is part way in. Push the server completely into the rack.
2. (Optional) Insert and tighten the thumbscrews that hold the front of the server to the rack.

Removing the Chassis From a Rack

1. Press the outer rail latch to release the chassis.
2. Carefully slide the chassis forward, off the outer rails and out of the chassis.

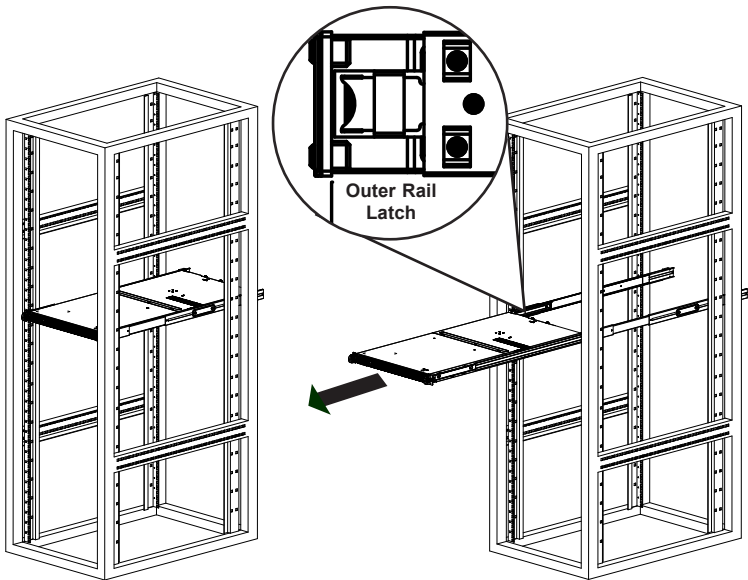

Figure 2-5. Server Installation and Removal

Note: The figure above is for illustrative purposes only. Always install servers at the bottom of the rack first.



Warning: Do not pick up the server with the front handles. They are designed to pull the system from a rack only.

Notes

Chapter 3

System Interface

3-1 Overview

The server includes a control panel on the front that houses power buttons and status monitoring lights, status lights on the externally accessible hard drives, and status lights for the power supply visible from the back of the chassis

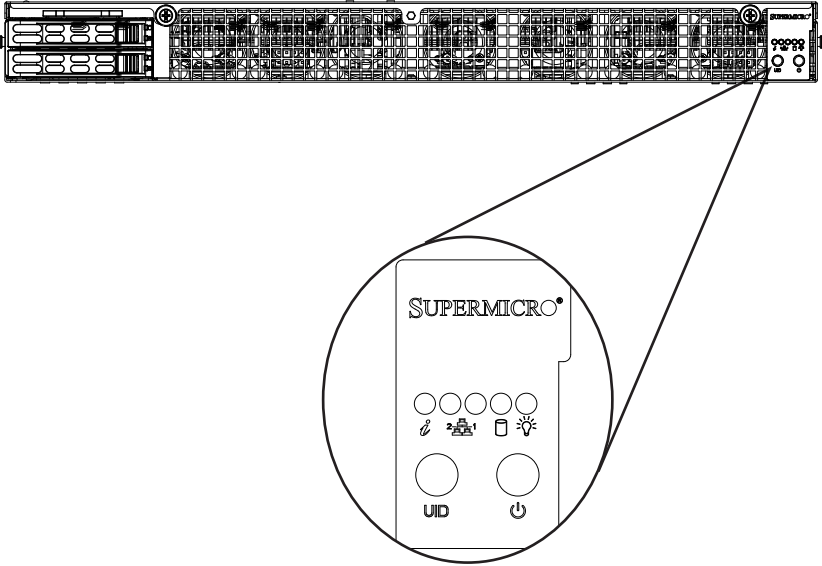

Figure 3-1. Control Panel

3-2 Control Panel Buttons

The chassis includes two push-buttons that control power to the system.



Power

The main power switch is used to apply or remove power from the power supply to the server system. Turning off system power with this button removes the main power but keeps standby power supplied to the system. Therefore, you must unplug system before servicing.



Unit Identification

The unit identification (UID) button turns on or off the blue light function of the Information LED and a blue LED on the rear of the chassis. These are used to locate the server in large racks and server banks.

3-3 Control Panel LEDs

There are five LEDs that provide status information about the system.



Power

Indicates power is being supplied to the system power supply units. This LED should normally be illuminated when the system is operating.



NIC2 and NIC1

Indicates network activity on LAN2 or LAN1 when flashing.

**HDD**

Indicates activity on the hard drive when flashing.

**Information LED**

Alerts operator of several states, as noted in the table below.

Information LED	
Status	Description
Continuously on and red	An overheat condition has occurred. (This may be caused by cable congestion.)
Blinking red (1Hz)	Fan failure, check for an inoperative fan.
Blinking red (0.25Hz)	Power failure, check for a non-operational power supply.
Solid blue	Local UID has been activated. Use this function to locate the server in a rack mount environment.
Blinking blue	Remote UID is on. Use this function to identify the server from a remote location.

Overheating

There are several possible responses if the system overheats.

Overheat Temperature Setting

Some backplanes allow the overheat temperature to be set at 45, 50, or 55 by changing a jumper setting. For more information, consult the backplane user manual at www.supermicro.com. (Click Support, then the Manuals link.)

Responses

If the server overheats:

1. Use the LEDs to determine the nature of the overheating condition.
2. Confirm that the chassis covers are installed properly.
3. Check the routing of the cables and make sure all fans are present and operating normally.
4. Verify that the heatsinks are installed properly.

3-4 Drive Carrier LEDs

The chassis includes externally accessible SAS/SATA drives. Each drive carrier displays two status LEDs on the front of the carrier.

	LED Color	Blinking Pattern	Behavior for Device
Activity LED	Blue	Solid On	SAS drive installed
	Blue	Blinking	I/O activity
Status LED	Red	Solid On	Failure of drive with RSTe support
	Red	Blinking at 1 Hz	Rebuild drive with RSTe support
	Red	Blinking with two blinks and one stop at 1 Hz	Hot spare for drive with RSTe support
	Red	On for five seconds, then off	Power on for drive with RSTe support
	Red	Blinking at 4 Hz	Identify drive with RSTe support

3-5 Power Supply LEDs

On the rear of the power supply module, an LED displays the status.

- **Solid Green:** When illuminated, indicates that the power supply is on.
- **Solid Amber:** When illuminated, indicates the power supply is plugged in and turned off, or the system is off but in an abnormal state.
- **Blinking Amber:** When blinking, this system power supply temperature has reached 63C. The system will automatically power-down when the power supply temperature reaches 70C and restart when the power supply temperature goes below 60C.

Notes

Chapter 4

Standardized Warning Statements for AC Systems

About Standardized Warning Statements

The following statements are industry standard warnings, provided to warn the user of situations which have the potential for bodily injury. Should you have questions or experience difficulty, contact Supermicro's Technical Support department for assistance. Only certified technicians should attempt to install or configure components.

Read this chapter in its entirety before installing or configuring components in the Supermicro chassis. Some warnings may not apply for your system.

These warnings may also be found on our web site at www.supermicro.com/about/policies/safety_information.cfm.

Warning Definition



Warning!

This warning symbol means danger. You are in a situation that could cause bodily injury. Before you work on any equipment, be aware of the hazards involved with electrical circuitry and be familiar with standard practices for preventing accidents.

警告の定義

この警告サインは危険を意味します。

人身事故につながる可能性がありますので、いずれの機器でも動作させる前に、電気回路に含まれる危険性に注意して、標準的な事故防止策に精通して下さい。

此警告符号代表危險。

您正处于可能受到严重伤害的工作环境中。在您使用设备开始工作之前，必须充分意识到触电的危险，并熟练掌握防止事故发生的标准工作程序。请根据每项警告结尾的声明号码找到此设备的安全性警告说明的翻译文本。

此警告符號代表危險。

您正處於可能身體可能會受損傷的工作環境中。在您使用任何設備之前，請注意觸電的危險，並且要熟悉預防事故發生的標準工作程序。請依照每一注意事項後的號碼找到相關的翻譯說明內容。

Warnung

WICHTIGE SICHERHEITSHINWEISE

Dieses Warnsymbol bedeutet Gefahr. Sie befinden sich in einer Situation, die zu Verletzungen führen kann. Machen Sie sich vor der Arbeit mit Geräten mit den Gefahren elektrischer Schaltungen und den üblichen Verfahren zur Vorbeugung vor Unfällen vertraut. Suchen Sie mit der am Ende jeder Warnung angegebenen Anweisungsnummer nach der jeweiligen Übersetzung in den übersetzten Sicherheitshinweisen, die zusammen mit diesem Gerät ausgeliefert wurden.

BEWAHREN SIE DIESE HINWEISE GUT AUF.

INSTRUCCIONES IMPORTANTES DE SEGURIDAD

Este símbolo de aviso indica peligro. Existe riesgo para su integridad física. Antes de manipular cualquier equipo, considere los riesgos de la corriente eléctrica y familiarícese con los procedimientos estándar de prevención de accidentes. Al final de cada advertencia encontrará el número que le ayudará a encontrar el texto traducido en el apartado de traducciones que acompaña a este dispositivo.

GUARDE ESTAS INSTRUCCIONES.

IMPORTANTES INFORMATIONS DE SÉCURITÉ

Ce symbole d'avertissement indique un danger. Vous vous trouvez dans une situation pouvant entraîner des blessures ou des dommages corporels. Avant de travailler sur un équipement, soyez conscient des dangers liés aux circuits électriques et familiarisez-vous avec les procédures couramment utilisées pour éviter les accidents. Pour prendre connaissance des traductions des avertissements figurant dans les consignes de sécurité traduites qui accompagnent cet appareil, référez-vous au numéro de l'instruction situé à la fin de chaque avertissement.

CONSERVEZ CES INFORMATIONS.

תאריך פרסום: 2010

האזהרה: אין להשתמש במכשיר זה ללא הסמכה מתאימה. שימוש לא נכון עלול לגרום לנזק למכשיר ולפגוע בביטחון המשתמש. יש לקרוא את כל ההנחיות והאזהרות לפני השימוש במכשיר. המידע המופיע בפרטים אלה אינו מהווה ייעוץ או אחריות. ייתכנו שינויים בפרטים אלה ללא הודעה מראש.

**تحذير! هذا الرمز يعني خطر اصابة في حالة يمكن ان تتسبب في اصابة جسدية .
 قبل ان تعمل على أي معدات يمكن على حطم بالمخاطر الناجمة عن الدوائر
 للكهربائية
 وكن على دراية بالعملات الوقائية لمنع وقوع أي حوادث
 استخدم رقم البيان المتصوص في نهاية كل تحذير للتحوير ترجمتها**

안전을 위한 주의사항

경고!

이 경고 기호는 위험이 있음을 알려 줍니다. 작업자의 신체에 부상을 야기 할 수 있는 상태에 있게 됩니다. 모든 장비에 대한 작업을 수행하기 전에 전기회로와 관련된 위험요소들을 확인하시고 사전에 사고를 방지할 수 있도록 표준 작업절차를 준수해 주시기 바랍니다.

해당 번역문을 찾기 위해 각 경고의 마지막 부분에 제공된 경고문 번호를 참조하십시오

BELANGRIJKE VEILIGHEIDSINSTRUCTIES

Dit waarschuwings symbool betekent gevaar. U verkeert in een situatie die lichamelijk letsel kan veroorzaken. Voordat u aan enige apparatuur gaat werken, dient u zich bewust te zijn van de bij een elektrische installatie betrokken risico's en dient u op de hoogte te zijn van de standaard procedures om ongelukken te voorkomen. Gebruik de nummers aan het eind van elke waarschuwing om deze te herleiden naar de desbetreffende locatie.

BEWAAR DEZE INSTRUCTIES

Installation Instructions



Warning!

Read the installation instructions before connecting the system to the power source.

設置手順書

システムを電源に接続する前に、設置手順書をお読み下さい。

警告

将此系统连接电源前，请先阅读安装说明。

警告

將系統與電源連接前，請先閱讀安裝說明。

Warnung

Vor dem Anschließen des Systems an die Stromquelle die Installationsanweisungen lesen.

¡Advertencia!

Lea las instrucciones de instalación antes de conectar el sistema a la red de alimentación.

Attention

Avant de brancher le système sur la source d'alimentation, consulter les directives d'installation.

⚠️ **התראה: קראו את הוראות התקנה לפני שתחברו את המערכת למקור האנרגיה.**

⚠️ قبل تركيب التركيب قبل توصيل النظام إلى مصدر الطاقة

시스템을 전원에 연결하기 전에 설치 안내를 읽어주시시오.

Waarschuwing

Raadpleeg de installatie-instructies voordat u het systeem op de voedingsbron aansluit.

Circuit Breaker



Warning!

This product relies on the building's installation for short-circuit (overcurrent) protection. Ensure that the protective device is rated not greater than: 250 V, 20 A.

サーキット・ブレーカー

この製品は、短絡(過電流)保護装置がある建物での設置を前提としています。

保護装置の定格が250 V、20 Aを超えないことを確認下さい。

警告

此产品的短路(过载电流)保护由建筑物的供电系统提供,确保短路保护设备的额定电流不大于250V,20A。

警告

此产品的短路(过载电流)保护由建筑物的供电系统提供,确保短路保护设备的额定电流不大于250V,20A。

Warnung

Dieses Produkt ist darauf angewiesen, dass im Gebäude ein Kurzschluss- bzw. Überstromschutz installiert ist. Stellen Sie sicher, dass der Nennwert der Schutzvorrichtung nicht mehr als: 250 V, 20 A beträgt.

¡Advertencia!

Este equipo utiliza el sistema de protección contra cortocircuitos (o sobrecorrientes) del edificio. Asegúrese de que el dispositivo de protección no sea superior a: 250 V, 20 A.

Attention

Pour ce qui est de la protection contre les courts-circuits (surtension), ce produit dépend de l'installation électrique du local. Vérifiez que le courant nominal du dispositif de protection n'est pas supérieur à :250 V, 20 A.

תוצר זה מסתמך על המנהל המבצע בלבד להגנה מפני קיצוץ (עומס יתר) של המערכת.
המבצע חייב לוודא שהמכשיר המגן אינו מעל 250V, 20A.

هذا المنتج يعتمد على معدات الحماية من الدوائر القصيرة التي تم تثبيتها في
المبنى
تأكد من أن تسمية للجهاز الوقائي ليس أكثر من 250V, 20A

경고!

이 제품은 전원의 단락(과전류)방지에 대해서 전적으로 건물의 관련 설비에 의존합니다. 보호장치의 정격이 반드시 250V(볼트), 20A(암페어)를 초과하지 않도록 해야 합니다.

Waarschuwing

Dit product is afhankelijk van de kortsluitbeveiliging (overspanning) van uw elektrische installatie. Controleer of het beveiligde apparaat niet groter gedimensioneerd is dan 220V, 20A.

Power Disconnection Warning



Warning!

The system must be disconnected from all sources of power and the power cord removed from the power supply module(s) before accessing the chassis interior to install or remove system components.

電源切斷の警告

システムコンポーネントの取り付けまたは取り外しのために、シャーシ内部にアクセスするには、システム電源はすべてのソースから切斷され、電源コードは電源モジュールから取り外す必要があります。

警告

在你打开机箱并安装或移除内部器件前，必须将系统完全断电，并移除电源线。

警告

在您打開機殼安裝或移除內部元件前，必須將系統完全斷電，並移除電源線。

Warnung

Das System muss von allen Quellen der Energie und vom Netzanschlusskabel getrennt sein, das von den Spg.Versorgungsteilmodulen entfernt wird, bevor es auf den Chassisinnenraum zurückgreift, um Systemsbestandteile anzubringen oder zu entfernen.

¡Advertencia!

El sistema debe ser disconnected de todas las fuentes de energía y del cable eléctrico quitado de los módulos de fuente de alimentación antes de tener acceso el interior del chasis para instalar o para quitar componentes de sistema.

Attention

Le système doit être débranché de toutes les sources de puissance ainsi que de son cordon d'alimentation secteur avant d'accéder à l'intérieur du châssis pour installer ou enlever des composants de système.

אזהרה!
יש לנתק את המערכת מכל מקורות החשמל ויש להסיר את כבל החשמל קודם לכן לפני גישה לחדק הפנימי של המערכת לצורך התקנת או הסרת רכיבים.

يجب فصل النظام من جميع مصادر الطاقة وإزالة سلك الكهرباء من وحدة امداد الطاقة قبل التوصل إلى المناطق الداخلية ليكامل تثبيت أو إزالة مكونات الجهاز

경고!

시스템에 부품들을 장착하거나 제거하기 위해서는 새시 내부에 접근하기 전에 반드시 전원 공급장치로부터 연결되어있는 모든 전원과 전기코드를 분리해주어야 합니다.

Waarschuwing

Voordat u toegang neemt tot het binnenwerk van de behuizing voor het installeren of verwijderen van systeem onderdelen, dient u alle spanningsbronnen en alle stroomkabels aangesloten op de voeding(en) van de behuizing te verwijderen

Equipment Installation



Warning!

Only trained and qualified personnel should be allowed to install, replace, or service this equipment.

機器の設置

トレーニングを受け認定された人だけがこの装置の設置、交換、またはサービスを許可されています。

警告

只有经过培训且具有资格的人员才能进行此设备的安装、更换和维修。

警告

只有經過受訓且具資格人員才可安裝、更換與維修此設備。

Warnung

Das Installieren, Ersetzen oder Bedienen dieser Ausrüstung sollte nur geschultem, qualifiziertem Personal gestattet werden.

¡Advertencia!

Solamente el personal calificado debe instalar, reemplazar o utilizar este equipo.

Attention

Il est vivement recommandé de confier l'installation, le remplacement et la maintenance de ces équipements à des personnels qualifiés et expérimentés.

אזהרה!
על מנת להקטין את הסיכונים ולהבטיח את אמינות המערכת, יש להשתמש רק באנשי צוות מוסמכים להקמת, החלפה או שימוש במכשיר.

يجب أن يسمح فقط للموظفين المؤهلين والمدربين لتثبيت واستبدال أو خدمة هذا الجهاز.

경고!

훈련을 받고 공인된 기술자만이 이 장비의 설치, 교체 또는 서비스를 수행할 수 있습니다.

Waarschuwing

Deze apparatuur mag alleen worden geïnstalleerd, vervangen of hersteld door geschoold en gekwalificeerd personeel.

Restricted Area



Warning!

This unit is intended for installation in restricted access areas. A restricted access area can be accessed only through the use of a special tool, lock and key, or other means of security. (This warning does not apply to workstations).

アクセス制限区域

このユニットは、アクセス制限区域に設置されることを想定しています。

アクセス制限区域は、特別なツール、鍵と錠前、その他のセキュリティの手段を用いてのみ出入りが可能です。

警告

此部件应安装在限制进出的场所，限制进出的场所指只能通过使用特殊工具、锁和钥匙或其它安全手段进出的场所。

警告

此裝置僅限安裝於進出管制區域，進出管制區域係指僅能以特殊工具、鎖頭及鑰匙或其他安全方式才能進入的區域。

Warnung

Diese Einheit ist zur Installation in Bereichen mit beschränktem Zutritt vorgesehen. Der Zutritt zu derartigen Bereichen ist nur mit einem Spezialwerkzeug, Schloss und Schlüssel oder einer sonstigen Sicherheitsvorkehrung möglich.

¡Advertencia!

Esta unidad ha sido diseñada para instalación en áreas de acceso restringido. Sólo puede obtenerse acceso a una de estas áreas mediante la utilización de una herramienta especial, cerradura con llave u otro medio de seguridad.

Attention

Cet appareil doit être installée dans des zones d'accès réservés. L'accès à une zone d'accès réservé n'est possible qu'en utilisant un outil spécial, un mécanisme de verrouillage et une clé, ou tout autre moyen de sécurité.

אזהרה על גישה סגורה

אזהרה!

יש להימנע מההיגיון באזורים שיש בהם תעלות גישה הנגישה לרובת בלבד
בלי אמצעים בלתי נשנים, קטועל אחר.

تم تخصيص هذه الوحدة لتثبيتها في مناطق مخطورة .
يمكن الوصول إلى منطقة مخطورة فقط من خلال استخدام أداة خاصة
كفل ومفتاح أو أي وسيلة أخرى للأمان

경고!

이 장치는 접근이 제한된 구역에 설치하도록 되어 있습니다. 특수도구, 잠금 장치 및 키, 또는 기타 보안 수단을 통해서만 접근 제한 구역에 들어갈 수 있습니다.

Waarschuwing

Dit apparaat is bedoeld voor installatie in gebieden met een beperkte toegang. Toegang tot dergelijke gebieden kunnen alleen verkregen worden door gebruik te maken van speciaal gereedschap, slot en sleutel of andere veiligheidsmaatregelen.

Battery Handling



Warning!

There is the danger of explosion if the battery is replaced incorrectly. Replace the battery only with the same or equivalent type recommended by the manufacturer. Dispose of used batteries according to the manufacturer's instructions

電池の取り扱い

電池交換が正しく行われなかった場合、破裂の危険性があります。交換する電池はメーカーが推奨する型、または同等のものを使用下さい。使用済電池は製造元の指示に従って処分して下さい。

警告

電池更換不當會有爆炸危險。請只使用同類電池或製造商推薦的功能相當的電池更換原有電池。請按製造商的說明處理廢舊電池。

警告

電池更換不當會有爆炸危險。請使用製造商建議之相同或功能相當的電池更換原有電池。請按照製造商的說明指示處理廢棄舊電池。

Warnung

Bei Einsetzen einer falschen Batterie besteht Explosionsgefahr. Ersetzen Sie die Batterie nur durch den gleichen oder vom Hersteller empfohlenen Batterietyp. Entsorgen Sie die benutzten Batterien nach den Anweisungen des Herstellers.

Attention

Danger d'explosion si la pile n'est pas remplacée correctement. Ne la remplacer que par une pile de type semblable ou équivalent, recommandée par le fabricant. Jeter les piles usagées conformément aux instructions du fabricant.

¡Advertencia!

Existe peligro de explosión si la batería se reemplaza de manera incorrecta. Reemplazar la batería exclusivamente con el mismo tipo o el equivalente recomendado por el fabricante. Desechar las baterías gastadas según las instrucciones del fabricante.

⚠️⚠️⚠️⚠️
קיימת סכנת פיצוץ של הסוללה במקרה החלפה בדרך לא תקינה. יש להחליף את הסוללה בלבד במסגרת תחזוקת יצרן המכשיר.

סילוק הסוללות המנוהטות יש לבצע לפי הוראות היצרן.

هناك خطر من انفجار في حالة استبدال البطارية بطريقة غير صحيحة. عليك استبدال البطارية فقط بنفس النوع أو ما يخلها كما أوصت به الشركة المصنعة. التخلص من البطاريات المستهلكة وفقاً لتعليمات الشركة المصنعة.

경고!

배터리가 올바르게 교체되지 않으면 폭발의 위험이 있습니다. 기존 배터리와 동일하거나 제조사에서 권장하는 동등한 종류의 배터리로만 교체해야 합니다. 제조사의 안내에 따라 사용된 배터리를 처리하여 주십시오.

Waarschuwing

Er is ontploffingsgevaar indien de batterij verkeerd vervangen wordt. Vervang de batterij slechts met hetzelfde of een equivalent type die door de fabrikant aanbevolen wordt. Gebruikte batterijen dienen overeenkomstig fabrieksvoorschriften afgevoerd te worden.

Redundant Power Supplies (if applicable to your system)



Warning!

This unit might have more than one power supply connection. All connections must be removed to de-energize the unit.

冗長電源装置

このユニットは複数の電源装置が接続されている場合があります。
ユニットの電源を切るためには、すべての接続を取り外さなければなりません。

警告

此部件连接的电源可能不止一个，必须将所有电源断开才能停止给该部件供电。

警告

此装置连接的电源可能不只一个，必须切断所有电源才能停止对该装置的供电。

Warnung

Dieses Gerät kann mehr als eine Stromzufuhr haben. Um sicherzustellen, dass der Einheit kein Strom zugeführt wird, müssen alle Verbindungen entfernt werden.

¡Advertencia!

Puede que esta unidad tenga más de una conexión para fuentes de alimentación. Para cortar por completo el suministro de energía, deben desconectarse todas las conexiones.

Attention

Cette unité peut avoir plus d'une connexion d'alimentation. Pour supprimer toute tension et tout courant électrique de l'unité, toutes les connexions d'alimentation doivent être débranchées.

אם קיים יותר מקשר אחד

אזהרה!
ליחידה יש יותר מקשר אחד של חשמל. יש להסיר את כל החיבורים על קשר לחשמל
הוא דו-קו.

قد يكون لهذا الجهاز عدة اتصالات بوحدة امداد الطاقة.
يجب إزالة كافة الاتصالات لعزل الوحدة عن الكهرباء.

경고!

이 장치에는 한 개 이상의 전원 공급 단자가 연결되어 있을 수 있습니다. 이 장치에 전원을 차단하기 위해서는 모든 연결 단자를 제거해야만 합니다.

Waarschuwing

Deze eenheid kan meer dan één stroomtoevoeraansluiting bevatten. Alle aansluitingen dienen verwijderd te worden om het apparaat stroomloos te maken.

Backplane Voltage (if applicable to your system)



Warning!

Hazardous voltage or energy is present on the backplane when the system is operating. Use caution when servicing.

バックプレーンの電圧

システムの稼働中は危険な電圧または電力が、バックプレーン上にかかっています。

修理する際にはご注意ください。

警告

当系统正在进行时，背板上有很危险的电压或能量，进行维修时务必小心。

警告

當系統正在進行時，背板上危險的電壓或能量，進行維修時務必小心。

Warnung

Wenn das System in Betrieb ist, treten auf der Rückwandplatine gefährliche Spannungen oder Energien auf. Vorsicht bei der Wartung.

¡Advertencia!

Cuando el sistema está en funcionamiento, el voltaje del plano trasero es peligroso. Tenga cuidado cuando lo revise.

Attention

Lorsque le système est en fonctionnement, des tensions électriques circulent sur le fond de panier. Prendre des précautions lors de la maintenance.

תנאי התקנה

אזהרה

יש להקפיד על כללי התקנה הנכונים כדי להבטיח את אמינות המערכת. יש להקפיד על כללי התקנה הנכונים.

هناك خطر من التيار الكهربائي أو الطاقة الموجودة على اللوحة عندما يكون النظام يعمل كن حذرا عند خدمة هذا الجهاز

경고!

시스템이 동작 중일 때 후면판 (Backplane)에는 위험한 전압이나 에너지가 발생합니다. 서비스 작업 시 주의하십시오.

Waarschuwing

Een gevaarlijke spanning of energie is aanwezig op de backplane wanneer het systeem in gebruik is. Voorzichtigheid is geboden tijdens het onderhoud.

Comply with Local and National Electrical Codes



Warning!

Installation of the equipment must comply with local and national electrical codes.

地方および国の電気規格に準拠

機器の取り付けはその地方および国の電気規格に準拠する必要があります。

警告

设备安装必须符合本地与本国电气法规。

警告

設備安裝必須符合本地與本國電氣法規。

Warnung

Die Installation der Geräte muss den Sicherheitsstandards entsprechen.

¡Advertencia!

La instalación del equipo debe cumplir con las normas de electricidad locales y nacionales.

Attention

L'équipement doit être installé conformément aux normes électriques nationales et locales.

תיאום והקני והחשמל המוני

אזהרה!

התקנת המוצר חייבת להיות תואמת לרשימת המוצרים והתקנות המקומיים והמדיניים.

تركيب المعدات الكهربائية يجب أن يمتثل للقوانين الوطنية والمحلية المتعلقة بالكهرباء

경고!

현 지역 및 국가의 전기 규정에 따라 장비를 설치해야 합니다.

Waarschuwing

Bij installatie van de apparatuur moet worden voldaan aan de lokale en nationale elektriciteitsvoorschriften.

Product Disposal



Warning!

Ultimate disposal of this product should be handled according to all national laws and regulations.

製品の廃棄

この製品を廃棄処分する場合、国の関係する全ての法律・条例に従い処理する必要があります。

警告

本产品的废弃处理应根据所有国家的法律和规章进行。

警告

本產品的廢棄處理應根據所有國家的法律和規章進行。

Warnung

Die Entsorgung dieses Produkts sollte gemäß allen Bestimmungen und Gesetzen des Landes erfolgen.

¡Advertencia!

Al deshacerse por completo de este producto debe seguir todas las leyes y reglamentos nacionales.

Attention

La mise au rebut ou le recyclage de ce produit sont généralement soumis à des lois et/ou directives de respect de l'environnement. Renseignez-vous auprès de l'organisme compétent.

תאליק והתקנה

אזהרה!

תאליק סופי של סופר זה חייב להיות באמצעות לוחיות התאליק והתקנה.

عند التخلص النهائي من هذا المنتج ينبغي التعامل معه وفقا لجميع القوانين واللوائح الوطنية

경고!

이 제품은 해당 국가의 관련 법규 및 규정에 따라 폐기되어야 합니다.

Waarschuwing

De uiteindelijke verwijdering van dit product dient te geschieden in overeenstemming met alle nationale wetten en reglementen.

Hot Swap Fan Warning (if applicable to your system)



Warning!

The fans might still be turning when you remove the fan assembly from the chassis. Keep fingers, screwdrivers, and other objects away from the openings in the fan assembly's housing.

ファン・ホットスワップの警告

シャーシから冷却ファン装置を取り外した際、ファンがまだ回転している可能性があります。ファンの開口部に、指、ドライバー、およびその他のものを近づけないで下さい。

警告

当您从机架移除风扇装置，风扇可能仍在转动。小心不要将手指、螺丝起子和其他物品太靠近风扇

警告

當您從機架移除風扇裝置，風扇可能仍在轉動。小心不要將手指、螺絲起子和其他物品太靠近風扇。

Warnung

Die Lüfter drehen sich u. U. noch, wenn die Lüfterbaugruppe aus dem Chassis genommen wird. Halten Sie Finger, Schraubendreher und andere Gegenstände von den Öffnungen des Lüftergehäuses entfernt.

¡Advertencia!

Los ventiladores podran dar vuelta cuando usted quite el montaje del ventilador del chasis. Mantenga los dedos, los destornilladores y todos los objetos lejos de las aberturas del ventilador

Attention

Il est possible que les ventilateurs soient toujours en rotation lorsque vous retirerez le bloc ventilateur du châssis. Prenez garde à ce que doigts, tournevis et autres objets soient éloignés du logement du bloc ventilateur.

경고!
 1. 팬을 제거할 때 팬이 여전히 회전하고 있을 수 있습니다. 손가락, 드라이버, 나사driver, 다른 물체들이 가까이 하지 않도록 배치해 주십시오.
 2. 팬의 회전하는 부분에서 손을 떼십시오.
 3. 팬의 회전하는 부분에서 손가락, 드라이버, 나사driver, 다른 물체들이 가까이 하지 않도록 배치해 주십시오.
 من الممكن أن المراوح لا تزال تدور عند إزالة كتلة المراوحة من الهيكل يجب إبقاء الأيدي ومعدات الياضي وغيرها من الأشياء بعيدا عن الفتحات في كتلة المراوحة.

경고!

새시로부터 팬 조립품을 제거할 때 팬은 여전히 회전하고 있을 수 있습니다. 팬 조립품 외관의 열려있는 부분들로부터 손가락 및 스크류드라이버, 다른 물체들이 가까이 하지 않도록 배치해 주십시오.

Waarschuwing

Het is mogelijk dat de ventilator nog draait tijdens het verwijderen van het ventilatorsamenstel uit het chassis. Houd uw vingers, schroevendraaiers en eventuele andere voorwerpen uit de buurt van de openingen in de ventilatorbehuizing.

Power Cable and AC Adapter



Warning!

When installing the product, use the provided or designated connection cables, power cables and AC adaptors. Using any other cables and adaptors could cause a malfunction or a fire. Electrical Appliance and Material Safety Law prohibits the use of UL or CSA -certified cables (that have UL/CSA shown on the code) for any other electrical devices than products designated by Supermicro only.

電源コードとACアダプター

製品を設置する場合、提供または指定された接続ケーブル、電源コードとACアダプターを使用下さい。他のケーブルやアダプタを使用すると故障や火災の原因になることがあります。電気用品安全法は、ULまたはCSA認定のケーブル(UL/CSEマークがコードに表記)をSupermicroが指定する製品以外に使用することを禁止しています。

警告

安装此产品时,请使用本身提供的或指定的连接线,电源线和电源适配器.使用其它线材或适配器可能会引起故障或火灾。除了Supermicro所指定的产品,电气用品和材料安全法律规定禁止使用未经UL或CSA认证的线材。(线材上会显示UL/CSA符号)。

警告

安装此产品时,请使用本身提供的或指定的连接线,电源线和电源适配器.使用其它线材或适配器可能会引起故障或火灾。除了Supermicro所指定的产品,电气用品和材料安全法律规定禁止使用未经UL或CSA认证的线材。(线材上会显示UL/CSA符號)。

Warnung

Bei der Installation des Produkts, die zur Verfügung gestellten oder benannt Anschlusskabel, Stromkabel und Netzteile. Verwendung anderer Kabel und Adapter kann zu einer Fehlfunktion oder ein Brand entstehen. Elektrische Geräte und Material Safety Law verbietet die Verwendung von UL-oder CSA-zertifizierte Kabel, UL oder CSA auf der Code für alle anderen elektrischen Geräte als Produkte von Supermicro nur bezeichnet gezeigt haben.

¡Advertencia!

Al instalar el producto, utilice los cables de conexión previstos o designados, los cables y adaptadores de CA. La utilización de otros cables y adaptadores podría ocasionar un mal funcionamiento o un incendio. Aparatos Eléctricos y la Ley de Seguridad del Material prohíbe el uso de UL o CSA cables certificados que tienen UL o CSA se muestra en el código de otros dispositivos eléctricos que los productos designados por Supermicro solamente.

Attention

Lors de l'installation du produit, utilisez les bables de connection fournis ou désigné. L'utilisation d'autres cables et adaptateurs peut provoquer un dysfonctionnement ou un incendie. Appareils électroménagers et de loi sur la sécurité Matériel interdit l'utilisation de UL ou CSA cables certifiés qui ont UL ou CSA indiqué sur le code pour tous les autres appareils électriques que les produits désignés par Supermicro seulement.

התקנת כבלים ומתאמים AC**אזהרה!**

במהלך התקנת המוצר, יש להשתמש בכבלים או מתאמים המסומנים על ידי UL או CSA. שימוש בכבלים או מתאמים אחרים עלול לגרום לתפקוד לא תקין של המוצר. שימוש בכבלים או מתאמים אחרים עלול לגרום לתפקוד לא תקין של המוצר. שימוש בכבלים או מתאמים אחרים עלול לגרום לתפקוד לא תקין של המוצר. שימוש בכבלים או מתאמים אחרים עלול לגרום לתפקוד לא תקין של המוצר.

עוד תרכיב ליהיזר ייבב אמתאם קיילאט אל וואסל סולאקאטא ללכר יפא
 ומסולאט אלאל אלענדד
 אלל - אן אמתאם איל קיילאט ומסולאט אכריל יאמב בל חלוט אלל אן חריר
 אן חריר הא אלל אלענא
 אלחזא ללכר יפא ומולא קארן אללאלא יאמר אמתאם קיילאט אן אן
 אלענא מן קאל
 איל אהזא ללכר יפא אכריל אכר אלענאט אלענא מן קאל Supermicro
 (אלל אלענא אמתאם UL/CSA)

경고!

제품을 설치할 때에는 제공되거나 지정된 연결케이블과 전원케이블, AC 어댑터를 사용해야 합니다. 그 밖의 다른 케이블들이나 어댑터들은 고장 또는 화재의 원인이 될 수 있습니다. 전기용품안전법 (Electrical Appliance and Material Safety Law)은 슈퍼마이크로에서 지정한 제품들 외에는 그 밖의 다른 전기 장치들을 위한 UL 또는 CSA에서 인증한 케이블(전선 위에 UL/CSA가 표시)들의 사용을 금지합니다.

Waarschuwing

Bij het installeren van het product, gebruik de meegeleverde of aangewezen kabels, stroomkabels en adapters. Het gebruik van andere kabels en adapters kan leiden tot een storing of een brand. Elektrisch apparaat en veiligheidsinformatiebladen wet verbiedt het gebruik van UL of CSA gecertificeerde kabels die UL of CSA die op de code voor andere elektrische apparaten dan de producten die door Supermicro alleen.

Notes

Chapter 5

Advanced Motherboard Setup

This chapter covers the steps required to install processors and heatsinks to the X10DGQ motherboard, connect the data and power cables and install add-on cards. All motherboard jumpers and connections are described and a layout and quick reference chart are included in this chapter. Remember to close the chassis completely when you have finished working on the motherboard to protect and cool the system sufficiently.

5-1 Handling the Motherboard

Static electrical discharge can damage electronic components. To prevent damage to printed circuit boards, it is important to handle them very carefully (see Chapter 4). Also note that the size and weight of the motherboard can cause it to bend if handled improperly, which may result in damage. To prevent the motherboard from bending, keep one hand under the center of the board to support it when handling.

The following measures are generally sufficient to protect your equipment from static discharge.

Precautions

- Use a grounded wrist strap designed to prevent static discharge.
- Touch a grounded metal object before removing any board from its antistatic bag.
- Handle a board by its edges only; do not touch its components, peripheral chips, memory modules or gold contacts.
- When handling chips or modules, avoid touching their pins.
- Put the motherboard, add-on cards and peripherals back into their antistatic bags when not in use.

Unpacking

The motherboard is shipped in antistatic packaging to avoid static damage. When unpacking the board, make sure the person handling it is static protected.

5-2 Installing the Processor and Heatsink

Notes:

- Always remove the power cord before adding, removing or changing a CPU.
- When receiving a motherboard without a processor pre-installed, make sure that the plastic CPU socket cap is in place and none of the socket pins are bent; otherwise, contact your retailer immediately.
- If you buy a CPU separately, use only an Intel-certified, multi-directional heatsink.
- Avoid placing direct pressure to the top of the processor package.
- Install the processor into the CPU socket before installing the heatsink.
- Refer to the Supermicro web site for updates on CPU support.

Installing an LGA 2011 Processor

Installing a CPU

1. There are two levers on the LGA 2011 socket. First press and release the load lever labeled "Open 1st".

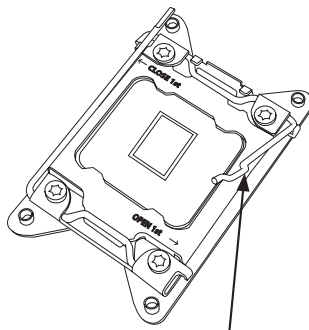

Release the lever labeled "Open 1st"

2. Press the second load lever labeled "Close 1st" to release the load plate from its locked position.

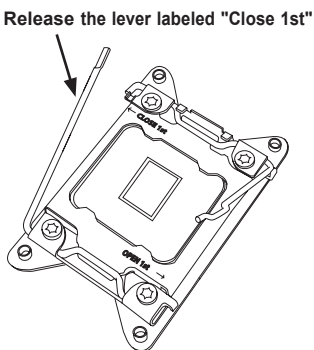

Release the lever labeled "Close 1st"

3. With the second lever fully retracted, gently push down on the "Open 1st" lever to loosen the load plate. Lift the load plate with your fingers to open it completely.

Open the load plate.

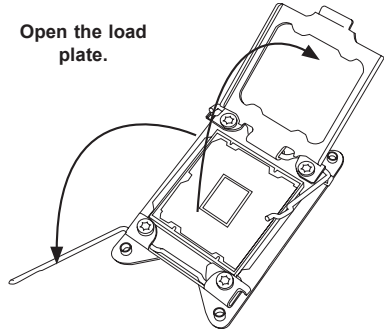

4. Pop the plastic cap marked "Warning" out of the load plate.
5. Holding the CPU carefully above the socket, orient the CPU so that all keys and edges will fit the socket.

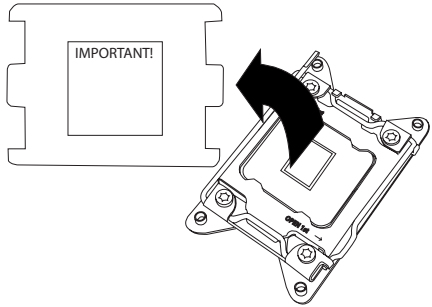

6. Carefully lower the CPU straight down into the socket. Do not move the CPU horizontally, and do not rub the pins of the socket. This may damage the CPU or the socket.

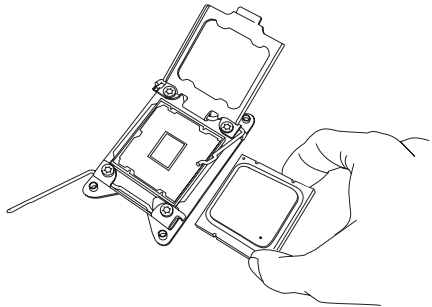

Caution: You can only install the CPU into the socket in one direction. Make sure that the CPU is properly inserted into the socket before closing the load plate. If it does not close properly, do not force it as it may damage your CPU. Instead, open the load plate again and double-check that the CPU is aligned properly.

7. With the "Close 1st" lever fully retracted, gently close the load plate.

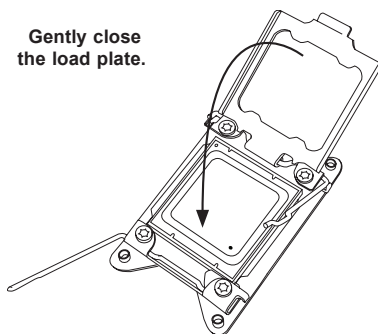

8. Make sure the locking mechanism on the "Close 1st" lever catches the lip of the load plate. Close and lock the "Close 1st" lever.

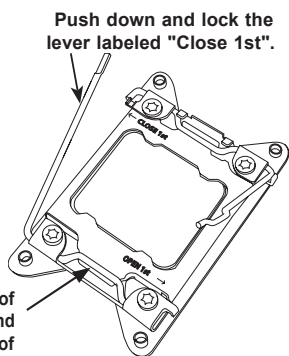

9. Close and lock the "Open 1st" lever.

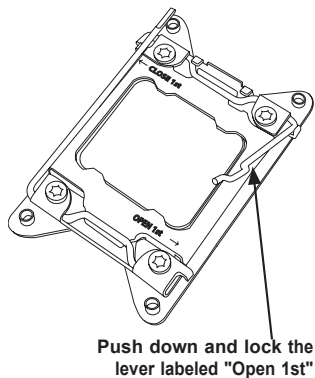

Installing a CPU Heatsink

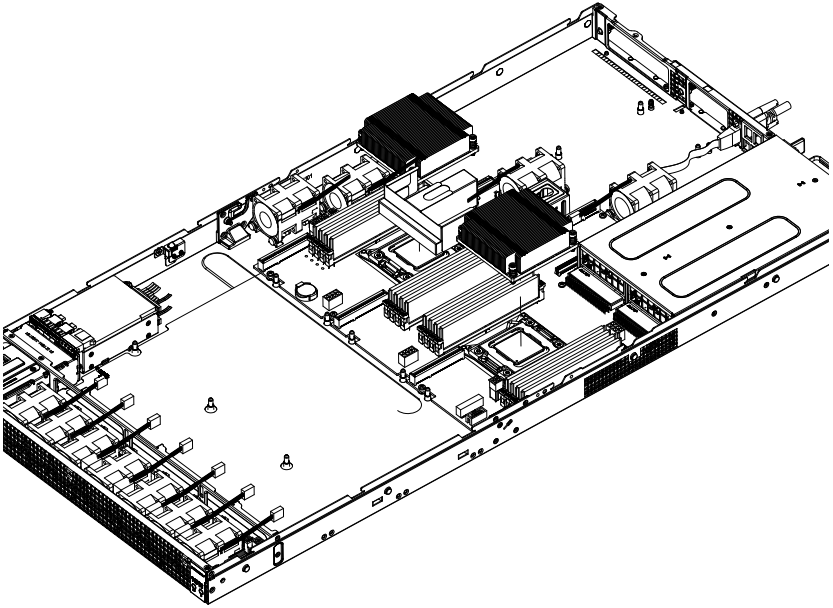

Figure 5-1. Heatsinks

Installing a Heatsink

1. Place the heatsink on top of the CPU so that the four mounting holes are aligned with those on the retention mechanism.
2. Screw in two diagonal screws (#1 and #2) until just snug—do not over-tighten and damage the CPU. Screw in the remaining screws.
3. Finish the installation by fully tightening all four screws.

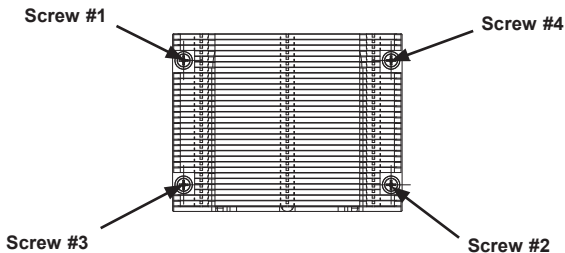

Figure 5-2. Heatsink Screw Order

Removing the Heatsink

Caution: We do not recommend removing the CPU or the heatsink. If you do need to remove the heatsink, please follow the instructions below to prevent damage to the CPU or the CPU socket.

1. Unplug the power cord from the power supply.
2. Unscrew and remove the heatsink screws in the opposite sequence shown in the picture above.
3. Hold the heatsink and gently wriggle it to loosen it from the CPU. (Do not use excessive force!)
4. Once the heatsink is loosened, remove it from the CPU.
5. Clean the surface of the CPU and the heatsink to get rid of the old thermal grease. Reapply the proper amount of thermal grease before re-installing the heatsink.

5-3 Connecting Cables

Now that the processors are installed, the next step is to connect the cables to the motherboard. These include the data (ribbon) cables for the peripherals and control panel and the power cables.

Connecting Data Cables

The cables used to transfer data from the peripheral devices have been carefully routed in preconfigured systems to prevent them from blocking the flow of cooling air that moves through the system from front to back. If you need to disconnect any of these cables, you should take care to reroute them as they were originally after reconnecting them and be aware of the pin 1 locations. If you are configuring the system, keep the airflow in mind when routing the cables.

Connecting Power Cables

The motherboard has two 50-pin primary power supply connectors designated JPW1 and JPW2. Connect the appropriate cable connectors from the power supply to JPW1 and JPW2 to provide power to the motherboard.

Connecting the Control Panel

JF1 contains header pins for the front control panel connectors. All JF1 wires have been bundled into single keyed ribbon cable to simplify their connection. The red wire in the ribbon cable plugs into pin 1 of JF1. Connect the other end of the cable to the Control Panel printed circuit board, located just behind the system status LEDs in the chassis.

See the Connector Definitions section in this chapter for details and pin descriptions of JF1.

5-4 Input/Output Ports

The rear panel I/O ports are connected to the motherboard by means of the add-on module.

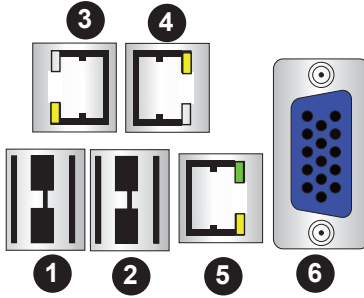

Figure 5-2. Rear Panel I/O Ports

1.	USB 3.0 Port
2.	USB 3.0 Port
3.	LAN 1
4.	LAN 2
5.	IPMI dedicated LAN
6.	VGA (blue)

LAN Ports

The 1028GQ-TR model offers two Gigabit LAN ports; the 1028GQ-TRT model features two 10-Gigabit LAN ports.

5-5 Installing Memory

For best performance, install memory modules of the same type and same speed in the slots as indicated in the tables on the following page.

Note: Check the Supermicro web site for recommended memory modules.

CAUTION

Exercise extreme care when installing or removing DIMM modules to prevent any possible damage.

Installing DIMMs

1. Insert the desired number of DIMMs into the memory slots, starting with slot P1-DIMMA1.
2. Push the release tabs outwards on both ends of the DIMM slot to unlock it.
3. Insert each DIMM vertically into its slot. Pay attention to the notch along the bottom of the module to prevent inserting the DIMM module incorrectly..
4. Use two thumbs together to press on both ends of the module straight down into the slot until the module snaps into place.

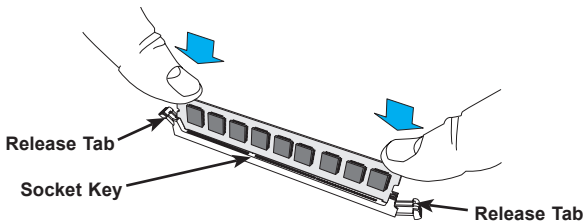

Figure 5-3. Installing DIMM into Slot

Releasing Memory Modules

Press the release tabs on both ends of the memory module to unlock it. Once it is loosened, remove the DIMM module from the memory slot.

Memory Support

The server features 16 DIMM slots that can support up to 1 TB of Load Reduction (LRDIMM) or up to 512 GB of Registered (RDIMM)/Non-volatile (NV-DIMM) ECC DDR4-2133/1866/1600 MHz memory. Memory speed support depends on the processors installed in the system. For the latest memory updates, refer to the Supermicro website at www.supermicro.com/products/motherboard.

Processor and Memory Module Population Configuration

For memory to work properly, follow the tables below for memory installation.

Processors and their Corresponding Memory Modules								
CPU#	Corresponding DIMM Modules							
CPU 1	P1-DIMMA1	P1-DIMMB1	P1-DIMMC1	P1-DIMMD1	P1-DIMMA2	P1-DIMMB2	P1-DIMMC2	P1-DIMMD2
CPU2	P2-DIMME1	P2-DIMMF1	P2-DIMMG1	P2-DIMMH1	P2-DIMME2	P2-DIMMF2	P2-DIMMG2	P2-DIMMH2

Processor and Memory Module Population for Optimal Performance	
Number of CPUs+DIMMs	CPU and Memory Population Configuration Table (For memory to work properly, please follow the instructions below.)
1 CPU & 2 DIMMs	CPU1 P1-DIMMA1/P1-DIMMB1
1 CPU & 4 DIMMs	CPU1 P1-DIMMA1/P1-DIMMB1, P1-DIMMC1/P1-DIMMD1
1 CPU & 5-8 DIMMs	CPU1 P1-DIMMA1/P1-DIMMB1, P1-DIMMC1/P1-DIMMD1 + Any memory pairs in P1-DIMMA2/P1-DIMMB2/P1-DIMMC2/P1-DIMMD2 slots
2 CPUs & 4 DIMMs	CPU1 + CPU2 P1-DIMMA1/P1-DIMMB1, P2-DIMME1/P2-DIMMF1
2 CPUs & 6 DIMMs	CPU1 + CPU2 P1-DIMMA1/P1-DIMMB1/P1-DIMMC1/P1-DIMMD1, P2-DIMME1/P2-DIMMF1
2 CPUs & 8 DIMMs	CPU1 + CPU2 P1-DIMMA1/P1-DIMMB1/P1-DIMMC1/P1-DIMMD1, P2-DIMME1/P2-DIMMF1/P2-DIMMG1/P2-DIMMH1
2 CPUs & 8-16 DIMMs	CPU1/CPU2 P1-DIMMA1/P1-DIMMB1/P1-DIMMC1/P1-DIMMD1, P2-DIMME1/P2-DIMMF1/P2-DIMMG1/P2-DIMMH1 + Any memory pairs in P1, P2 DIMM slots
2 CPUs & 16 DIMMs	CPU1/CPU2 P1-DIMMA1/P1-DIMMB1/P1-DIMMC1/P1-DIMMD1, P2-DIMME1/P2-DIMMF1/P2-DIMMG1/P2-DIMMH1, P1-DIMMA2/P1-DIMMB2/P1-DIMMC2/P1-DIMMD2, P2-DIMME2/P2-DIMMF2/P2-DIMMG2/P2-DIMMH2

Caution: For the memory to work properly, install DIMMs of the same type and speed.

Populating RDIM/LRDIMM DDR4 ECC Memory Modules

Type	Ranks Per DIMM and Data Width	DIMM Capacity (GB)		Speed (MT/s), Slot per Channel (SPC) & DIMM per Channel (DPC)		
				1 Slot Per Channel	2 Slots Per Channel	
		4Gb	8Gb	1DPC	1DPC	2DPC
				1.2V	1.2V	1.2V
RDIMM	SRx4	8GB	16GB	2133	2133	1866
RDIMM	SRx8	4GB	8GB	2133	2133	1866
RDIMM	DRx8	8GB	16GB	2133	2133	1866
RDIMM	DRx4	16GB	32GB	2133	2133	1866
LRDIMM	QRx4	32GB	64GB	2133	2133	2133

5-6 Motherboard Details

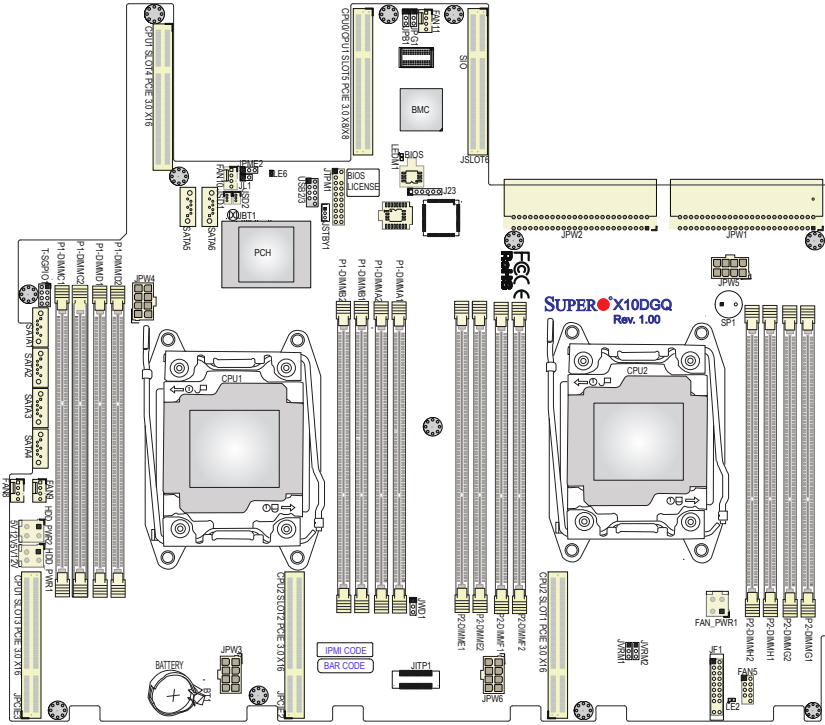

Figure 5-4. X10DGQ Layout

Notes

- "■" indicates the location of "Pin 1".
- Jumpers/LEDs not indicated are for testing purposes only. Also, components that are not documented in this manual are reserved for internal use only.

Indicators		
LED	Description (State)	Status
LE2	System Power LED	On: System power on
LE6	Power Health LED	Green: System power on
LEDM1	BMC Heartbeat LED	Green (blinking): BMC normal

Motherboard Quick Reference

Jumpers		
Jumper	Description	Default Setting
JBT1	Clear CMOS/Reset BIOS Configuration	See Chapter 2
JPB1	BMC Enable	Pins 1-2 (Enabled)
JPG1	VGA Enable	Pins 1-2 (Enabled)
JPME2	Manufacture Mode (ME) Select	Pins 1-2 (Normal)
JWD1	Watch Dog	Pins 1-2 (Reset)

Connectors	
Connectors	Description
FAN5	9-pin fan header
FAN8-FAN11	CPU/system 4-pin cooling fan headers 8-11
HDD_PWR 1/2	HDD power headers 1/2
FAN_PWR1	Fan power connector
JF1	Front control panel header
JL1	Chassis intrusion header
JSD1/2	SATA DOM (Device-On-Module) power connectors 1/2
JPTM1	TPM (Trusted Platform Module)/Port 80
JPW3/4/5/6	8-pin power connectors 3-6
JPW1/JPW2	Proprietary 50-pin power connectors 1/2
JSTBY1	Standby power header
SATA1-6	SATA connectors 1-6 supported by Intel PCH (SATA5/6: support Supermicro SuperDOM with power pins built-in)
(CPU1) Slot3/4	PCI-E 3.0 x16 slots 3/4
(CPU2) Slot1/2	PCI-E 3.0 x16 slots 1/2
(CPU0/1) Slot5	PCI-E 3.0 x8/x8 slot 5
SIO Slot	Riser card for rear I/O support
SP1	Internal speaker/buzzer
T-SGPIO1	Serial_link General Purpose I/O header 1 (for SATA1-2)
USB2/3	USB 2.0 header w/support of two connections USB 2/3

5-7 Connector Definitions

Power Connectors

Two 50-pin proprietary power connectors (JPW1/JPW2) are used to provide main power to your system. Four 8-pin power connectors, located at JPW3/JPW4/JPW5/JPW6, provide power to PCI-E expansion cards. In addition, two 4-pin power connectors (HDD_PWR1/HDD_PWR2) are used for onboard HDDs, while another 4-pin power connector (FAN_PWR1) powers the fan board AOM-QG-FAN.

Caution: To provide adequate power to your system and to avoid damaging the power supply or the motherboard, be sure to connect all power connectors mentioned above to the power supply when using the devices mentioned. Failure in doing so may void the manufacturer warranty on your power supply and motherboard..

12V 8-pin Power Connector Pin Definitions	
Pins	Definition
1 through 3	+12V
4 through 8	Ground

(Required)

HDD_PWR1/HDD_PWR2 Pin Definitions	
Pins	Definition
1-2	Ground
3	+5V
4	+12V

(Required)

FAN_PWR1 Pin Definitions	
Pins	Definition
1-2	Ground
3-4	+12V

(Required)

Control Panel Connector

The connector for the control panel on the front of the chassis is JF1.

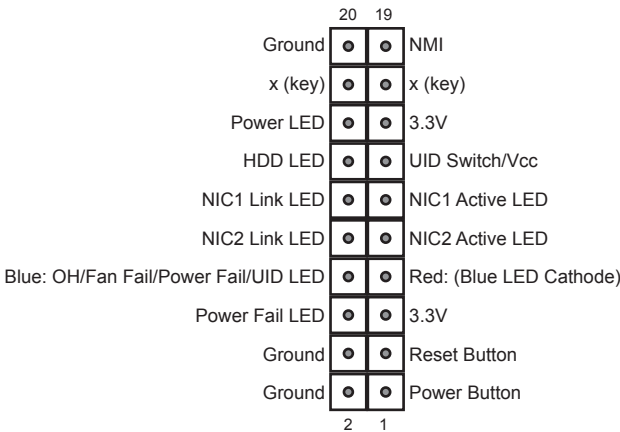

Figure 5-5. Front Control Panel Header Pins (JF1)

NMI Button

The non-maskable interrupt button header is located on pins 19 and 20 of JF1. Refer to the table on the right for pin definitions.

NMI Button Pin Definitions (JF1)	
Pin#	Definition
19	Control
20	Ground

Power LED

The Power LED connection is located on pins 15 and 16 of JF1. Refer to the table on the right for pin definitions.

Power LED Pin Definitions (JF1)	
Pin#	Definition
15	3.3V
16	PWR LED

HDD LED/UID Switch

The HDD LED/UID switch connections are located on pins 13/14 of JF1. Attach an LED cable to display HDD activity. Attach a cable to pin 13 to use UID button. See the table on the right for pin definitions.

HDD/UID Switch Pin Definitions (JF1)	
Pin#	Definition
13	UID Switch
14	HDD Active

NIC1/NIC2 LED

The NIC (Network Interface Controller) LED connections for GLAN port 1 are located on pins 11 and 12 of JF1, and the LED connection for GLAN Port 2 are on pins 9 and 10. Attach the NIC LED cables here to display network activity. Refer to the table on the right for pin definitions.

GLAN 1/2 LED Pin Definitions (JF1)	
Pin#	Definition
9	NIC 2 Activity LED
10	NIC 2 Link LED
11	NIC 1 Activity LED
12	NIC 1 Link LED

Note: The NIC LED connections for 10G_LAN Ports 3/4 is located on LED1.

Overheat (OH)/Fan Fail/PWR Fail/ UID LED

Connect an LED cable to pins 7 and 8 of Front Control Panel to use the Overheat/Fan Fail/Power Fail and UID LED connections. The Red LED on pin 8 provides warnings of overheat, fan failure or power failure. The Blue LED on pin 7 works as the front panel UID LED indicator. Refer to the table on the right for pin definitions.

OH/Fan Fail/ PWR Fail/Blue_ UID LED Pin Definitions (JF1)	
Pin#	Definition
7	Blue_UID LED
8	OH/Fan Fail/Power Fail

OH/Fan Fail/PWR Fail LED Status (Red LED)	
State	Definition
Off	Normal
On	Overheat
Flashing	Fan Fail

Power Fail LED

The Power Fail LED connection is located on pins 5 and 6 of JF1. Refer to the table on the right for pin definitions.

PWR Fail LED Pin Definitions (JF1)	
Pin#	Definition
5	3.3V
6	PWR Supply Fail

Reset Button

The Reset Button connection is located on pins 3 and 4 of JF1. Attach it to the hardware reset switch on the computer case. Refer to the table on the right for pin definitions.

Reset Button Pin Definitions (JF1)	
Pin#	Definition
3	Reset
4	Ground

Power Button

The Power Button connection is located on pins 1 and 2 of JF1. Momentarily contacting both pins will power on/off the system. This button can also be configured to function as a suspend button (see the Power Button Mode setting in BIOS). To turn off the power when set to suspend mode, depress the button for at least 4 seconds. Refer to the table on the right for pin definitions.

Power Button Pin Definitions (JF1)	
Pin#	Definition
1	Signal
2	Ground

Other Connectors

Fan Headers

The 4-pin fan headers are backward compatible with traditional 3-pin fans, however fan speed control is available for 4-pin fans only. The fan speeds are controlled by IPMI.

Headers FAN5 (9-pin) and FAN_PWR1 (4-pin) connect to the fan board in the front of the chassis (Fans 1-7). Four-pin headers FAN8-FAN11 connect to the rear GPU fans, and the PCI and I/O add-on module fans, if present.

4-Pin Fan Header Pin Definitions	
Pin#	Definition
1	Ground
2	+12V
3	Tachometer
4	Pulse Width Modulation (PWM)

DOM Power Connectors

Two power connectors for SATA DOM (Disk On Module) devices are located at JSD1 and JSD2. These connectors are used with Supermicro SuperDOMs to provide backward-compatible power support to non-Supermicro SATADOMs that require external power supply.

DOM PWR Pin Definitions	
Pin#	Definition
1	+5V
2	Ground
3	Ground

TPM Header/Port 80

A Trusted Platform Module/Port 80 header is located at JTPM1 to provide TPM support and Port 80 connection. Use this header to enhance system performance and data security. See the table on the right for pin definitions.

TPM/Port 80 Header Pin Definitions			
Pin #	Definition	Pin #	Definition
1	LCLK	2	GND
3	LFRAME#	4	<(KEY)>
5	LRESET#	6	+5V (X)
7	LAD 3	8	LAD 2
9	+3.3V	10	LAD1
11	LAD0	12	GND
13	SMB_CLK4	14	SMB_DAT4
15	+3V_DUAL	16	SERIRQ
17	GND	18	CLKRUN# (X)
19	LPCPD#	20	LDRQ# (X)

Standby Power Header

The onboard standby power header is located at JSTBY1 on the motherboard. See the table on the right for pin definitions. (You must also have a card with the standby power connector and a cable to use this feature.)

Standby PWR Pin Definitions	
Pin#	Definition
1	+5V Standby
2	Ground
3	No Connection

I-SGPIO2 Header

A Serial-Link General Purpose Input/Output header (I-SGPIO2) supports a serial-link interface for onboard SATA connections.

I-SGPIO Pin Definitions			
Pin#	Definition	Pin	Definition
1	NC	2	NC
3	Ground	4	Data
5	Load	6	Ground
7	Clock	8	N

NC = No Connection

Internal Speaker

The internal speaker (SP1) provides audible indications for beep codes.

Internal Speaker Pin Definition		
Pin#	Definitions	
Pin 1	Pos. (+)	Beep In
Pin 2	Neg. (-)	Alarm Speaker

Chassis Intrusion

A Chassis Intrusion header is located at JL1. Attach an appropriate cable from the chassis to alert an intrusion when the chassis is opened.

Chassis Intrusion Pin Definitions	
Pin#	Definition
1	Intrusion Input
2	Ground

Universal Serial Bus (USB)

Two USB 3.0 ports (USB 0/1) are located on the rear I/O panel. In addition, a header located next to the PCH chip provides two USB 2.0 connections (USB 2/3). Cables are not included.

SIO Slot

JSLOT6 is the slot for the rear I/O add-on module.

PCI Slot

CPU0/CPU1 SLOT5 PCIE 3.0 x8/x8 is the slot for the riser card (RSC-GR-A88) that enables two low-profile PCIe expansion cards.

GPU Slots

The slots for the GPU riser cards are:

- CPU2 SLOT1 PCIE 3.0 x16
- CPU2 SLOT2 PCIE 3.0 x16
- CPU1 SLOT3 PCIE 3.0 x16
- CPU1 SLOT4 PCIE 3.0 x16

5-8 Jumper Settings

Explanation of Jumpers

To modify the operation of the motherboard, jumpers can be used to choose between optional settings. Jumpers create shorts between two pins to change the function of the connector. Pin 1 is identified with a square solder pad on the printed circuit board. See the diagram at right for an example of jumping pins 1 and 2. Refer to the motherboard layout page for jumper locations.

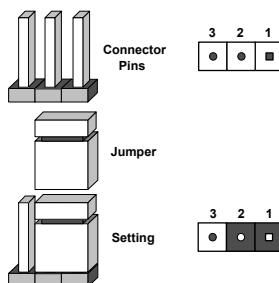

Note: On two-pin jumpers, "Closed" means the jumper is on and "Open" means the jumper is off the pins.

CMOS Clear

JBT1 is used to clear CMOS and will also clear any passwords. Instead of pins, this jumper consists of contact pads to prevent accidentally clearing the contents of CMOS.

To clear CMOS

1. First power down the system and unplug the power cord(s).
2. With the power disconnected, short the CMOS pads with a metal object such as a small screwdriver.
3. Remove the screwdriver (or shorting device).
4. Reconnect the power cord(s) and power on the system.

Note: Do not use the PW_ON connector to clear CMOS.

VGA Enable/Disable

JPG1 allows you to enable or disable the onboard VGA port. The default position is on pins 1 and 2 to enable VGA.

VGA Enable/Disable Jumper Settings	
Jumper Setting	Definition
Pins 1-2	Enabled
Pins 2-3	Disabled

BMC Enable

Jumper JPB1 allows you to enable the embedded onboard (Baseboard Management controller (BMC) to provide IPMI 2.0 support on the motherboard.

BMC Enable Jumper Settings	
Jumper Setting	Definition
Pins 1-2	BMC Enable
Pins 2-3	Normal

ME Manufacturing Mode Select

Close pin 2 and pin 3 of jumper JPME2 to bypass SPI flash security and force the system to operate in the Manufacturer (ME) mode, allowing the user to flash the system firmware from a host server for system setting modifications.

ME Mode Select Jumper Settings	
Jumper Setting	Definition
Pins 1-2	Normal (Default)
Pins 2-3	Manufacture Mode

Watch Dog Enable/Disable

Watch Dog (JWD1) is a system monitor that can reboot the system when a software application hangs. Close pins 1-2 to reset the system if an application hangs. Close pins 2-3 to generate non-maskable interrupt signals for the application that hangs. See the table on the right for jumper settings. Watch Dog must also be enabled in the BIOS

Watch Dog Jumper Settings	
Jumper Setting	Definition
Pins 1-2	Reset
Pins 2-3	NMI
Open	Disabled

5-9 Onboard Indicators

LAN1/2 Port LEDs

The Ethernet ports on the rear I/O panel have two indicators. On each port, the LED on the right indicates activity by blinking amber. The Link LED on the left indicates the speed of the connection. It may be green, amber, or off. See the table on the right.

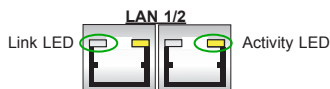

LAN Link Indicator LED Settings	
Color	Definition
Off	No Connection, 10 or 100 Mbps
Green	10 Gbps (1028GQ-TRT only)
Amber	1 Gbps

IPMI Dedicated LAN LEDs

A dedicated IPMI LAN port is located on the rear I/O panel. The LED on the right indicates activity by blinking amber. The Link LED on the left indicates the speed of the connection. It may be green, amber, or off. See the table on the right..

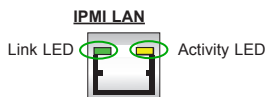

IPMI LAN Speed LED	
Color	Definition
Off	10 Mbps, or No Connection
Green	100 Mbps
Amber	1 Gbps

BMC Heartbeat LED

A BMC Heartbeat LED is located at LEDM1. When this LED is blinking, BMC is functioning normally.

BMC Heartbeat LED Status	
Color/State	Definition
Green: Blinking	BMC: Normal

System_Power Good LED

The System_Power Good LED is located at LE2. When it is on, system power is normal.

System PWR LED Status	
State	Description
On	Power Normal

Power Health LED

An onboard Power Health LED is located at LE6. See the table at right for indications.

Power Health LED Status	
State	Description
Green	System power on
Amber	Standby power only
Red	System power failure

5-10 SATA Ports

Six Serial ATA ports (SATA1-SATA6), supported by the Intel PCH, are located on the motherboard. SATA5/6, colored in yellow, are used with Supermicro SuperDOM (Disk-on-Module) connectors with power pins built in. Supermicro SuperDOM connectors are backward-compatible with regular SATA HDDs and SATA DOMs that require power cables.

Note: Refer to the Intel SATA HostRAID User's Guide posted on our website at, <http://www.supermicro.com> for more information.

5-11 Installing Software

The Supermicro ftp site contains drivers and utilities for your system at <ftp://ftp.supermicro.com>. Some of these must be installed, such as the chipset driver.

After accessing the ftp site, go into the CDR_Images directory and locate the ISO file for your motherboard. Download this file to create a CD/DVD of the drivers and utilities it contains. (You may also use a utility to extract the ISO file if preferred.)

Another option is to go to the Supermicro Website at <http://www.supermicro.com/products/>. Find the product page for your motherboard here, where you may download individual drivers and utilities.

After creating a CD/DVD with the ISO files, insert the disk into the CD/DVD drive on your system and the display shown in Figure 5-6 should appear.

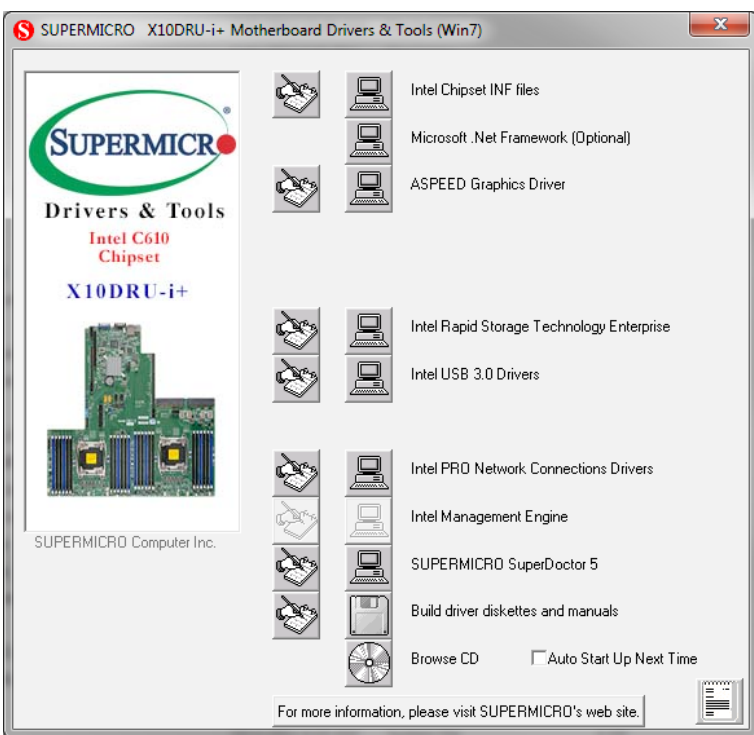

Figure 5-6. Driver Installation Display Screen

Note: Click the icons showing a hand writing on paper to view the readme files for each item. Click the computer icons to the right of these items to install each item (from top to the bottom) one at a time. **After installing each item, you must re-boot the system before moving on to the next item on the list.** The bottom icon with a CD on it allows you to view the entire contents.

SuperDoctor® 5

The Supermicro SuperDoctor 5 is a hardware and operating system services monitoring program that functions in a command-line or web-based interface in Windows and Linux operating systems. The program monitors system health information such as CPU temperature, system voltages, system power consumption, fan speed, and provides alerts via email or Simple Network Management Protocol (SNMP).

SuperDoctor 5 comes in local and remote management versions and can be used with Nagios to maximize your system monitoring needs. With SuperDoctor 5 Management Server (SSM Server), you can remotely control power on/off and reset chassis intrusion for multiple systems with SuperDoctor 5 or IPMI. SD5 Management Server monitors HTTP, FTP, and SMTP services to optimize the efficiency of your operation.

Note: The default User Name and Password for SuperDoctor 5 is ADMIN/ADMIN.

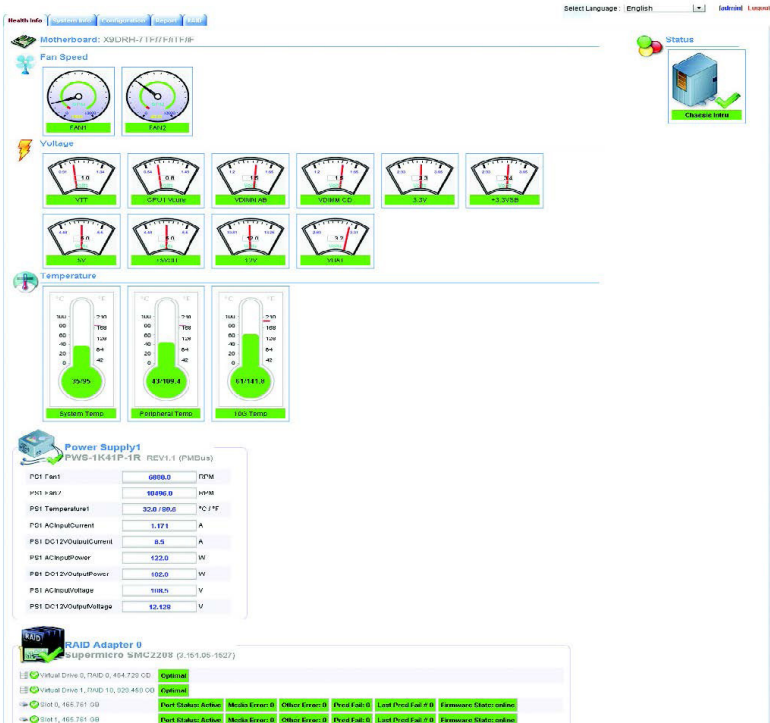

Figure 5-7. SuperDoctor 5 Interface Display Screen (Health Information)



Figure 5-8. SuperDoctor 5 Interface Display Screen (Remote Control)

Note: The SuperDoctor 5 program and User's Manual can be downloaded from the Supermicro web site at http://www.supermicro.com/products/info/sms_sd5.cfm. For Linux, we recommend that you use the SuperDoctor II application instead.

5-12 Onboard Battery

Please handle used batteries carefully. Do not damage the battery in any way; a damaged battery may release hazardous materials into the environment. Do not discard a used battery in the garbage or a public landfill. Please comply with the regulations set up by your local hazardous waste management agency to dispose of your used battery properly.

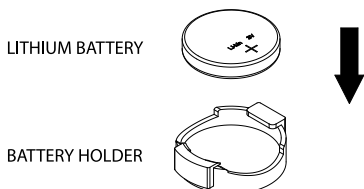

Figure 5-9. Installing the Onboard Battery

Chapter 6

Advanced Chassis Setup

This chapter covers the steps required to install components and perform maintenance on the SC118GQE-RK03 chassis. The only tool required is a Phillips screwdriver.

Review the warnings and precautions before setting up or servicing components. These include information in Chapter 4: *Warning Statements for AC Systems*.

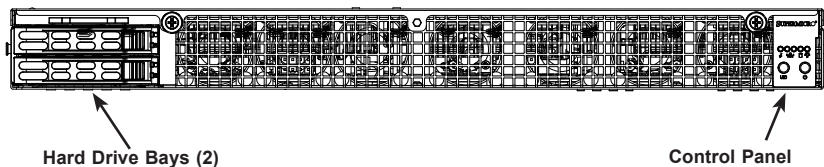

Figure 6-1. Chassis Front View

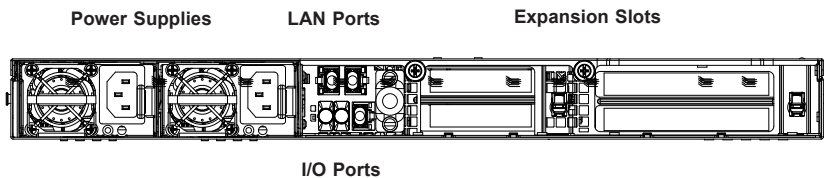

Figure 6-2. Chassis Rear View

6-1 Static-Sensitive Devices

Electrostatic Discharge (ESD) can damage electronic components. To prevent damage to any printed circuit boards (PCBs), it is important to handle them very carefully. The following measures are generally sufficient to protect your equipment from ESD damage.

Precautions

- Use a grounded wrist strap designed to prevent static discharge.
- Touch a grounded metal object before removing any board from its antistatic bag.
- Handle a board by its edges only; do not touch its components, peripheral chips, memory modules or gold contacts.
- When handling chips or modules, avoid touching their pins.
- Put the serverboard, add-on cards and peripherals back into their antistatic bags when not in use.
- For grounding purposes, make sure your computer chassis provides excellent conductivity between the power supply, the case, the mounting fasteners and the serverboard.

6-2 Removing Power

Before performing most setup or maintenance tasks, ensure that power has been removed from the system.

1. If the system is operating, use the operating system to power down, following the on-screen prompts.
2. After the system has completely shut-down, carefully grasp the head of the power cord and gently pull it out of the back of the power supply. If your system has dual power supplies, remove the cords from both power supplies.
3. Disconnect the cord from the power strip or wall outlet.

6-3 Removing the Chassis Cover

The SC118GQE has a two piece cover. For either the front cover or the rear cover:

1. Unscrew the two thumb screws on the end of the chassis.
2. Remove the screw securing the cover to each side of the chassis.
3. Pull the cover towards the end of the chassis and off.

Caution: Do not operate the server without the cover in place for long periods of time. The chassis cover helps to allow proper airflow and prevent overheating

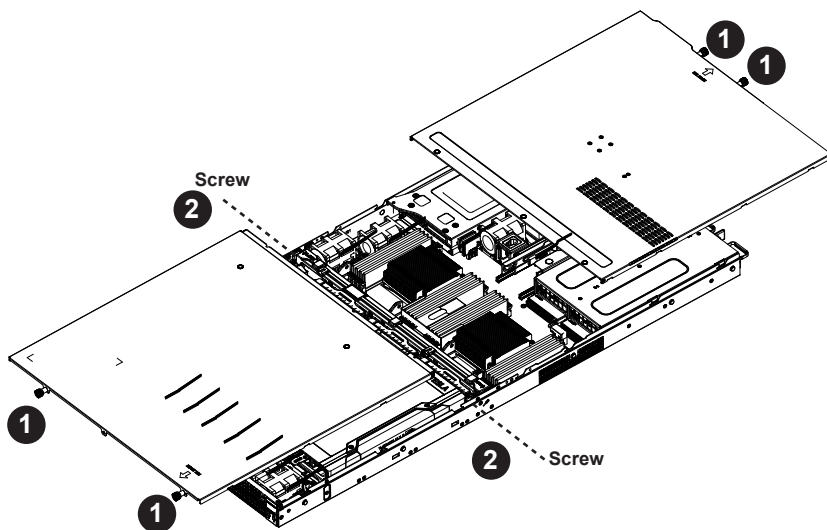

Figure 6-2. Accessing the Inside of the System

6-4 Control Panel

The control panel, located on the front of the chassis, must be connected to the JF1 connector on the serverboard to provide you with system status indicators. These wires have been bundled together as a ribbon cable to simplify the connection. Connect the cable from JF1 on the serverboard to the appropriate header on the Control Panel printed circuit board. Make sure the red wire plugs into pin 1 on both connectors. Pull all excess cabling out of the airflow path.

The control panel LEDs inform you of system status. See "Chapter 3: System Interface" for details. Details on the JF1 header can be found in "Chapter 5: Advanced Serverboard Setup."

6-5 Hard Drive Installation

The SC118GQE chassis has two externally accessible hot-swap 2.5" drive bays and space for two internal fixed 2.5" drives.

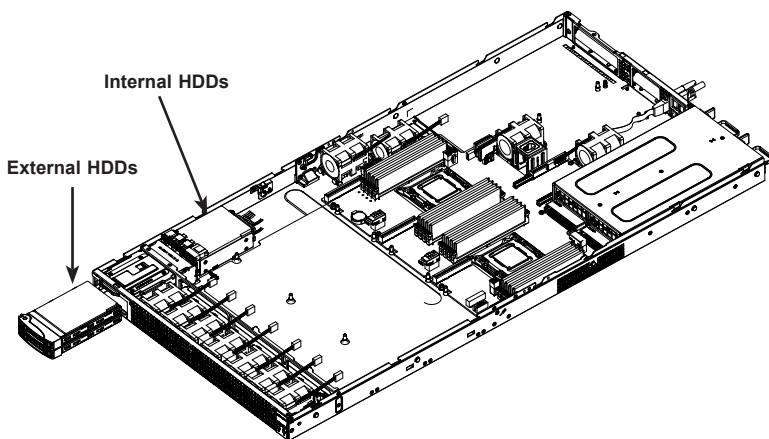

Figure 6-3. Drive Bays

Note: Enterprise level hard disk drives are recommended for use in Supermicro chassis and servers. For information on recommended HDDs, visit the Supermicro Web site at <http://www.supermicro.com/products/info/files/storage/SAS-CompList.pdf>.

Externally Accessible Drives

The two hot-swap drives are mounted in drive carriers to simplify their installation and removal from the chassis. System power may remain on when removing carriers with drives installed. These carriers also help promote proper airflow for the drive bays. For this reason, even carriers without drives must remain in the chassis.

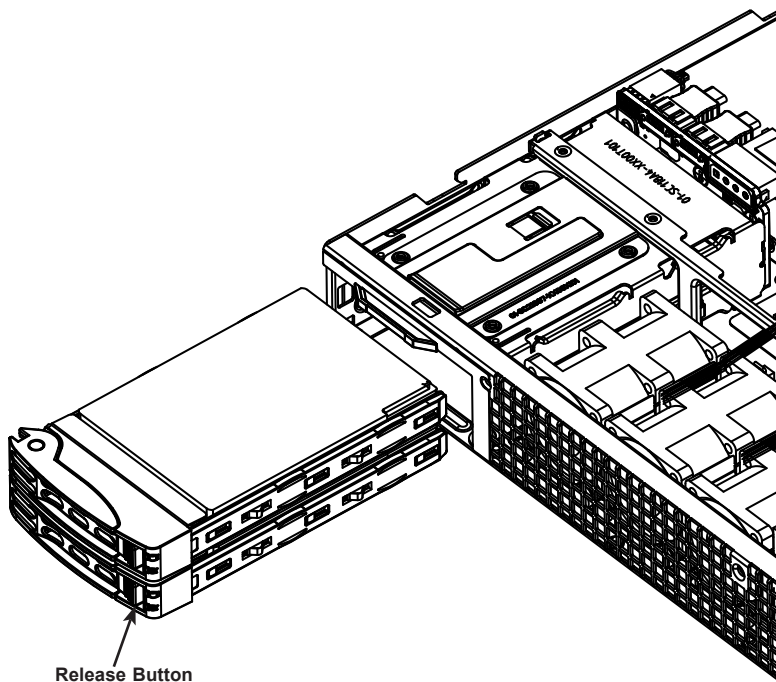

Figure 6-4. Removing a Drive from the Server

Removing Hard Drive Carrier from the Chassis

1. Press the release button on the drive carrier. This extends the drive carrier handle.
2. Use the handle to pull the drive out of the chassis.
3. Remove the dummy drive from the carrier (Figure 6-5).

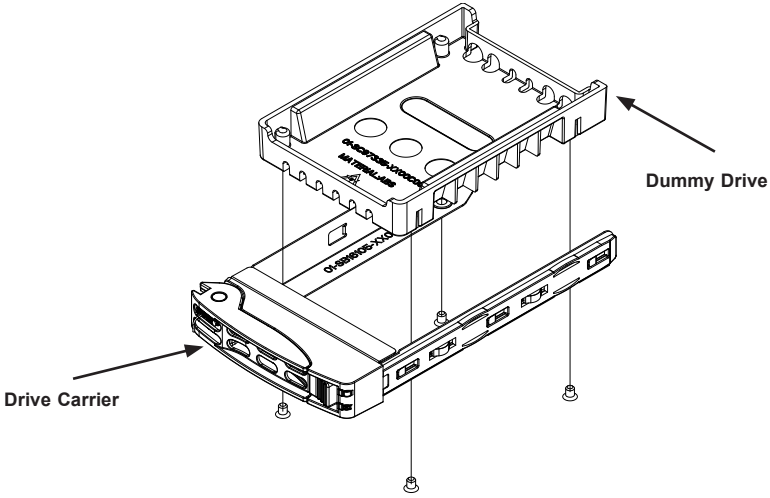

Figure 6-5. Removing a Dummy Drive from Carrier

Installing a Drive into the Carrier

1. Remove the dummy drive from the carrier by removing four screws.
2. Install a new drive into the carrier with the printed circuit board side facing down so that the mounting holes in the drive align with those in the carrier.

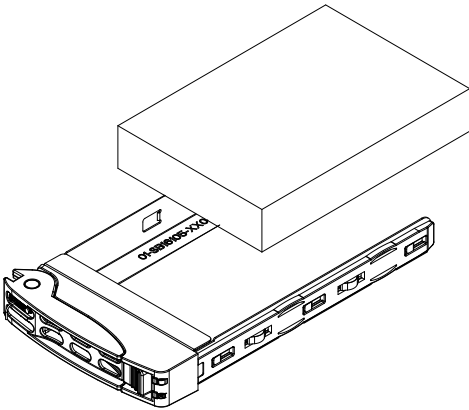

Figure 6-6. Installing a Drive into the Carrier

3. Secure the hard drive into the carrier with the screws.
4. Open the drive carrier handle and use it push the carrier assembly into the chassis.
5. Gently close the drive carrier handle to secure the drive and carrier into the chassis drive bay.

Caution: Except for short periods of time while swapping hard drives, do not operate the server without the carriers in the drive bays.

Internal Drives

The system supports one or two 2.5" fixed hard disk drives, using the included mounting bracket.

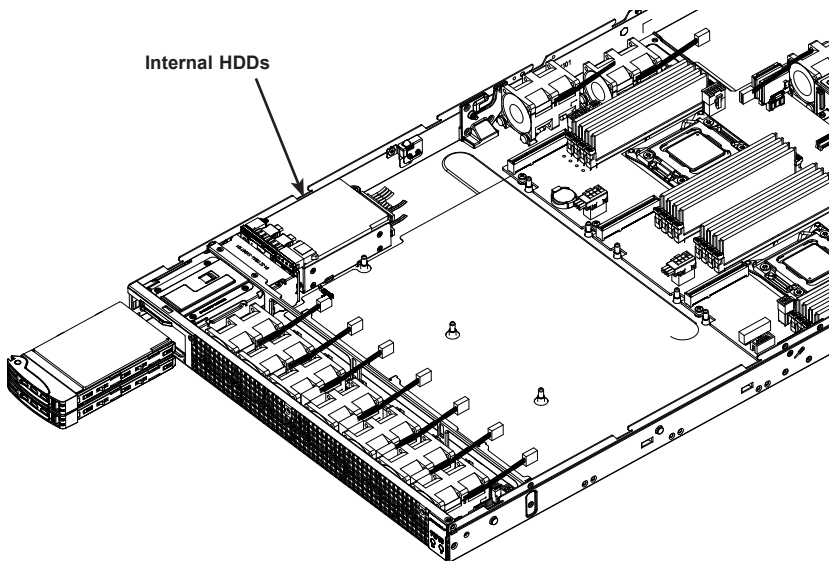

Figure 6-7. Internal HDD Position

Installing Internal Drives

1. Mount the drives in the bracket, securing them with screws.
2. Secure the bracket onto the chassis floor.
3. Attach cables from the drives to the motherboard.

6-6 Adding Expansion Cards

The system supports up to four graphic processor units (GPUs) and two low-profile PCIe expansion cards.

Graphic Processor Units

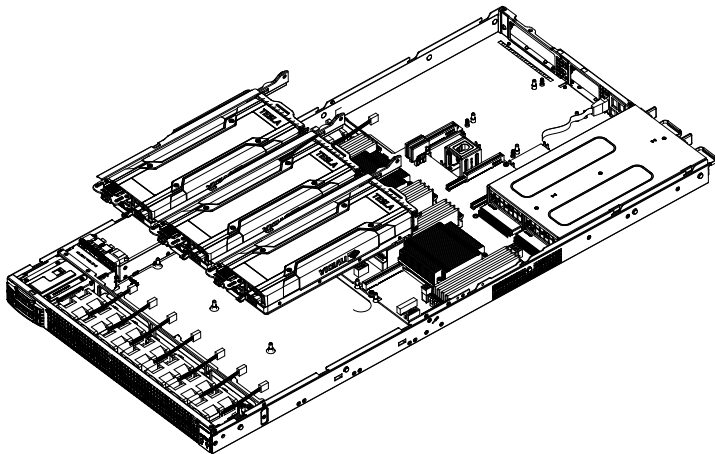

Figure 6-8. Front GPUs

Installing the Front GPUs

Installing the front GPUs requires riser cards, RSC-G-6.

1. Remove the riser card bracket.
2. Attach the riser card to the bracket.
3. Insert the GPU into the riser card slot.
4. Cable up.

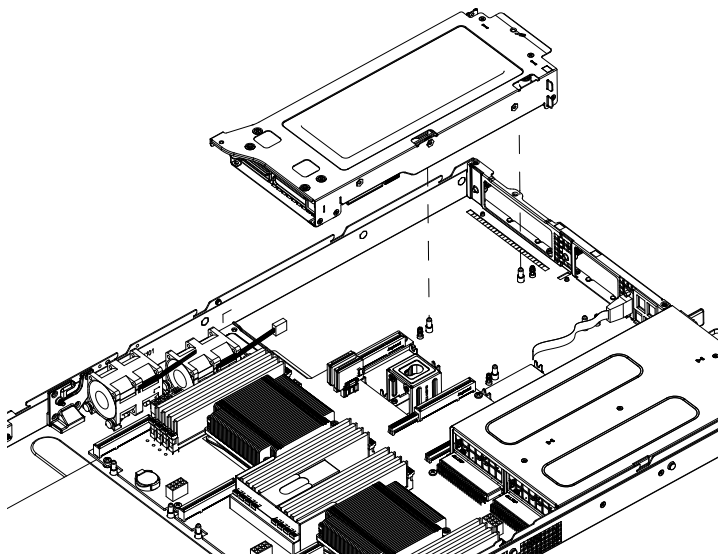

Figure 6-9. Rear GPU

Installing the rear GPU uses the riser card, RSC-GR-6.

Installing the Rear GPU

1. Remove the chassis bracket.
2. Attach the riser card to the bracket.
3. Insert the GPU into the riser card slot.
4. Cable up. See the next page for routing and cable reference.
5. Insert the riser card into motherboard slot and secure the bracket to chassis rear.

Cable Reference					
Cable Set	Part Number	Description (GPU, connector type, length)			Quantity/ Server
K80/M60	CBL-PWEX-0782	GPU1	8pin	55cm	1
	CBL-PWEX-0783	GPU2+3	8pin	39cm	2
	CBL-PWEX-0814	GPU4	8pin	11cm	1
K40	CBL-PWEX-0784	GPU1	6+2pin	55cm	1
	CBL-PWEX-0785	GPU2+3	6+2pin	39cm	2
	CBL-PWEX-0786	GPU4	6+2pin	11cm	1
GTX Titan X/ GTX 980TI	CBL-PWEX-0790	GPU1	8pin, 6pin	57cm	1
	CBL-PWEX-0791	GPU2+3	8pin, 6pin	36cm	2
	CBL-PWEX-0792	GPU4	8pin, 6pin	30cm	1
GTX 980	CBL-PWEX-0815	GPU1	6pin, 6pin	57cm	1
	CBL-PWEX-0816	GPU2+3	6pin, 6pin	36cm	2
	CBL-PWEX-0817	GPU4	6pin, 6pin	30cm	1
Xeon Phi	CBL-PWEX-0787	GPU1	6+2pin, 6pin	57cm	1
	CBL-PWEX-0788	GPU2+3	6+2pin, 6pin	38cm	2
	CBL-PWEX-0789	GPU4	6+2pin, 6pin	12cm	1

Note: This GPU numbering does not reflect GPU detection in IPMI/OS.

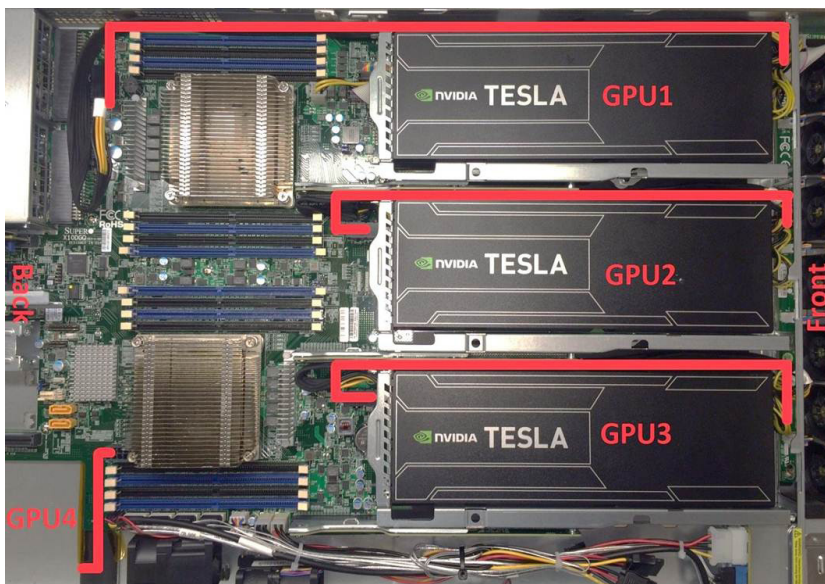

Figure 6-10. GPU Cable Routing

PCI

A riser card on chassis bracket allows you to add one or two low-profile PCI expansion cards. All expansion cards are PCI-Express 3.0. Installation requires the riser card RSC-GR-6.

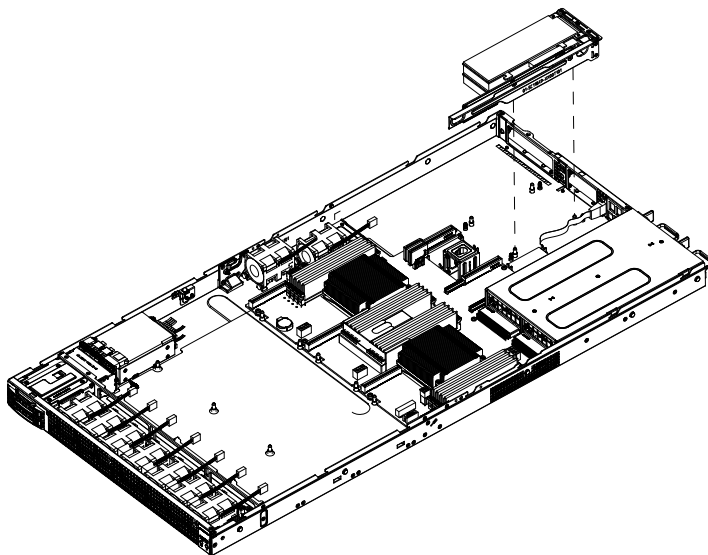

Figure 6-10. PCI Expansion Cards

Installing the Rear PCI Expansion Cards

1. Remove the chassis bracket.
2. Attach the riser card to the bracket.
3. Insert the PCI expansion card into the riser card slot.
4. Cable up.
5. Insert the riser card into motherboard slot and secure the bracket to chassis rear.

6-7 Cooling

System Fans

The standard chassis contains nine 4-cm counter-rotating, high-performance fans. Two more expansion card fans are available.

Fan speed is controlled by system temperature via IPMI. If a fan fails, the remaining fan will ramp up to full speed and the overheat/fan fail LED on the control panel will turn on. Replace any failed fan at your earliest convenience with the same type and model (the system can continue to run with a failed fan).

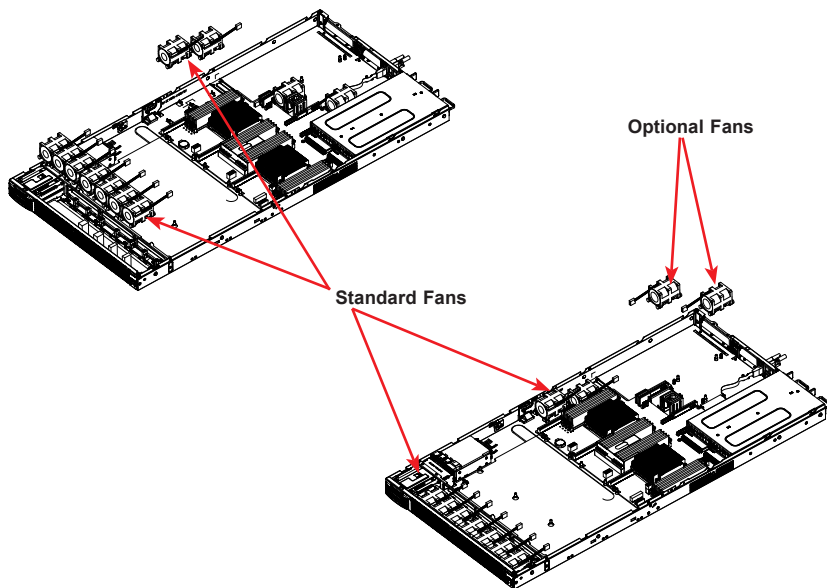

Figure 6-11. System Fans

Remove the top chassis cover while the system is still running to determine which of the fans has failed. Then power down the system before replacing a fan. .

Replacing System Fans

1. After determining which fan has failed, turn off the system power.
2. Unplug the fan wiring from the serverboard and remove the failed fan.
3. Press the fan release tab to lift the failed fan from the chassis and pull it completely from the chassis.

4. Place the new fan into the vacant space in the housing while making sure the arrows on the top of the fan (indicating air direction) point in the same direction as the arrows on the other fans.
5. Power up the system and check that the fan is working properly before replacing the chassis cover.

Air Shroud and Block

Cooling is also improved by means of an air block and an air shroud to channel the air flow. The mylar shroud covers the CPUs and memory.

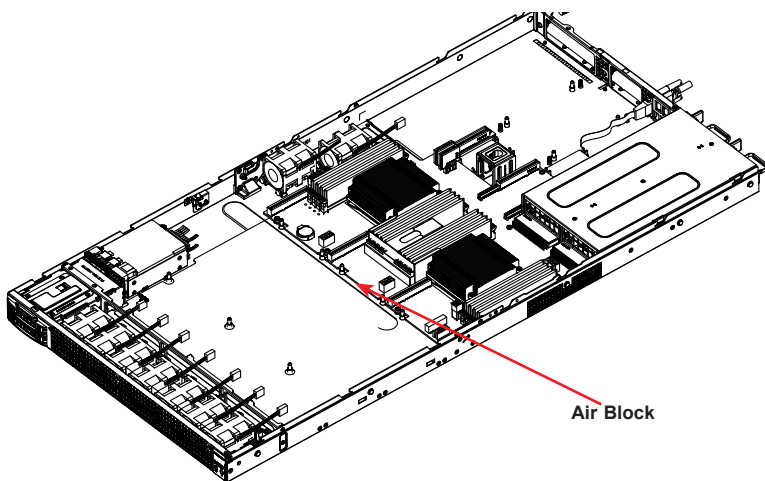

6-8 Power Supply

The 1028GQ-TR(T) has a 2000 watt redundant hot-plug power supply consisting of two power modules. Each power supply module has an auto-switching capability, which enables it to automatically sense and operate at a 100V - 240V input voltage.

Replacing a Power Supply Module

If either of the two power supply modules fail, the other module will take the full load and allow the system to continue operation without interruption. The Power Fail LED will illuminate and remain on until the failed unit has been replaced. Replacement units can be ordered directly from Supermicro. Replace the failed hot-swap unit with another identical power supply unit. The power supply modules can be replaced without powering down the system.

Replacing the Power Supply

1. Unplug the AC power cord from the failed power supply module.
2. Depress the release button on the power supply module.
3. Use the handle to pull the module straight out of the chassis.
4. Push the new power supply unit into the power bay until it clicks.
5. Plug the AC power cord back into the unit and power up the server.

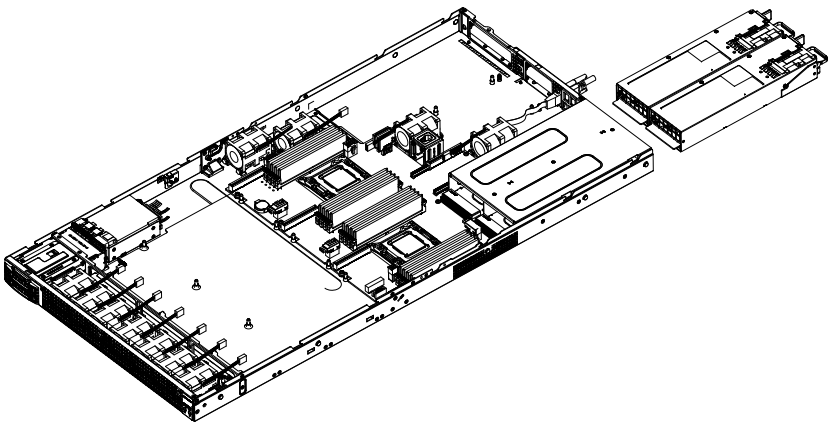

Figure 6-11. Removing/Replacing the Power Supply

Notes

Chapter 7

BIOS

7-1 Introduction

This chapter describes the AMI BIOS setup utility for the X10DGQ. It also provides the instructions on how to navigate the AMI BIOS setup utility screens. The AMI ROM BIOS is stored in a Flash EEPROM and can be easily updated.

Starting BIOS Setup Utility

To enter the AMI BIOS setup utility screens, press the key while the system is booting up.

Note: In most cases, the key is used to invoke the AMI BIOS setup screen. There are a few cases when other keys are used, such as <F3>, <F4>, etc.

Each main BIOS menu option is described in this manual. The Main BIOS setup menu screen has two main frames. The left frame displays all the options that can be configured. Grayed-out options cannot be configured. Options in blue can be configured by the user. The right frame displays the key legend. Above the key legend is an area reserved for informational text. When an option is selected in the left frame, it is highlighted in white. Often informational text will accompany it.

Note: The AMI BIOS has default informational messages built in. The manufacturer retains the option to include, omit, or change any of these informational messages.

The AMI BIOS setup utility uses a key-based navigation system called "hot keys." Most of the AMI BIOS setup utility "hot keys" can be used at any time during setup navigation. These keys include <F3>, <F4>, <Enter>, <ESC>, arrow keys, etc.

Note 1: Options printed in **Bold** are default settings.

Note 2: <F3> is used to load optimal default settings. <F4> is used to save the settings and exit the setup utility.

How To Change the Configuration Data

The configuration data that determines the system parameters may be changed by entering the AMI BIOS setup utility. This setup utility can be accessed by pressing <Delete> at the appropriate time during system boot.

Note: For AMI UEFI BIOS Recovery, please refer to the UEFI BIOS Recovery User Guide posted @ <http://www.supermicro.com/support/manuals/>.

Starting the Setup Utility

Normally, the only visible Power-On Self-Test (POST) routine is the memory test. As the memory is being tested, press the <Delete> key to enter the main menu of the AMI BIOS setup utility. From the main menu, you can access the other setup screens. An AMI BIOS identification string is displayed at the left bottom corner of the screen below the copyright message.

Caution: Do not upgrade the BIOS unless your system has a BIOS-related issue. Flashing the wrong BIOS can cause irreparable damage to the system. In no event shall the manufacturer be liable for direct, indirect, special, incidental, or consequential damage arising from a BIOS update. If you have to update the BIOS, do not shut down or reset the system while the BIOS is being updated to avoid possible boot failure.

7-2 Main Setup

When you first enter the AMI BIOS setup utility, you will enter the Main setup screen. You can always return to the Main setup screen by selecting the Main tab on the top of the screen. The Main BIOS Setup screen is shown below.

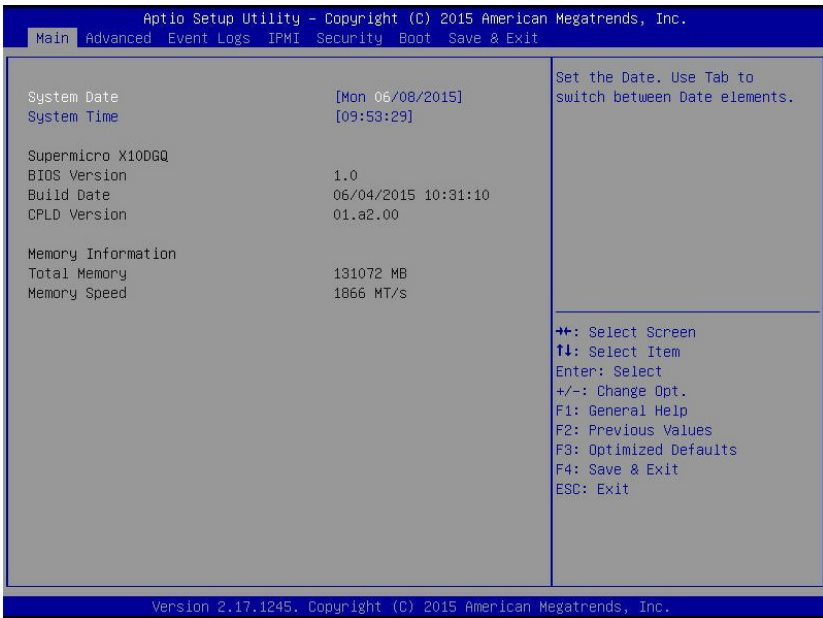

The AMI BIOS Main menu displays the following information:

System Date/System Time

Use this item to change the system date and time using the arrow keys. Enter new values through the keyboard and press <Enter>. Press the <Tab> key to move between fields. The date must be entered in Day MM/DD/YYYY format. The time is entered in HH:MM:SS format. (**Note:** The time is in the 24-hour format. For example, 5:30 P.M. appears as 17:30:00.).

Supermicro X10DGQ**BIOS Version**

This item displays the SMC version of the BIOS ROM used in this system.

Build Date

This item displays the date that the BIOS setup utility was built.

CPLD Version

This item displays the version of 'Complex Programmable Logic Device' (CPLD) used in this system.

Memory Information**Total Memory**

This item displays the amount of memory that is available in the system.

Memory Speed

This item displays the speed of memory modules installed in the system.

7-3 Advanced Setup Configurations

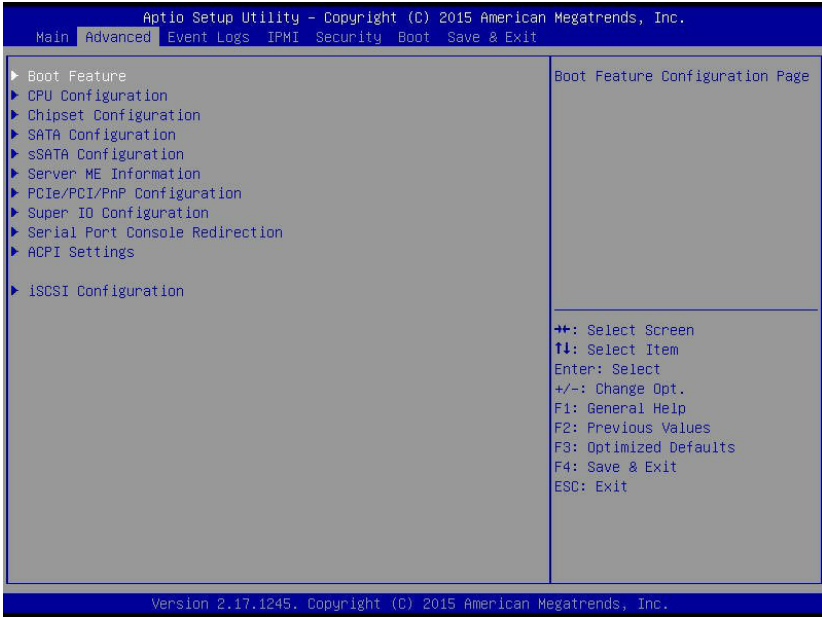

Select the Advanced tab to access the following submenu items.

▶ Boot Features

Boot Configuration

Quiet Boot

Use this item to select bootup screen display between POST messages and the OEM logo. Select Disabled to display the POST messages. Select Enabled to display the OEM logo instead of the normal POST messages. The options are **Enabled** and Disabled.

CSM (Compatibility Support Module) Support

Select Enabled to enable CSM booting support which will allow a UEFI-compatible device to boot from a system that uses a legacy BIOS ROM. The options are **Enabled** and Disabled.

AddOn ROM Display Mode

Use this item to set the display mode for the Option ROM. Select Keep Current to use the current AddOn ROM Display setting. Select Force BIOS to use the Option

ROM display set by the system BIOS. The options are **Force BIOS** and **Keep Current**.

Bootup Num-Lock

Use this item to set the power-on state for the Numlock key. The options are **Off** and **On**.

Wait For 'F1' If Error

Select **Enabled** to force the system to wait until the 'F1' key is pressed when an error occurs. The options are **Disabled** and **Enabled**.

Interrupt 19 Capture

Interrupt 19 is the software interrupt that handles the boot disk function. When this item is set to **Immediate**, the BIOS ROM of the host adaptors will immediately capture Interrupt 19 at bootup and allow the drives that are attached to these host adaptors to function as bootable disks. If this item is set to **Postponed**, the BIOS ROM of the host adaptors will only capture Interrupt 19 during bootup from a legacy device. The options are **Immediate** and **Postponed**.

Re-try Boot

If this item is set to **Enabled**, the system BIOS will continuously try to boot from the selected boot drive. The options are **Disabled**, **Legacy Boot**, and **EFI Boot**.

Power Configuration

Watch Dog Function

If enabled, the Watch Dog timer will allow the system to automatically reboot when a non-recoverable error that lasts for more than five minutes occurs. The options are **Enabled** and **Disabled**.

Power Button Function

If this item is set to **Instant Off**, the system will power off immediately as soon as the user presses the power button. If this item is set to **4 Seconds Override**, the system will power off when the user presses the power button for 4 seconds or longer. The options are **Instant Off** and **4 Seconds Override**.

Restore on AC Power Loss

Use this item to set the power state after a power outage. Select **Stay Off** for the system power to remain off after a power outage. Select **Power On** to turn on the system power after a power outage. Select **Last State** to allow the system to resume its last power state before a power outage. The options are **Power On**, **Stay Off**, and **Last State**.

►CPU Configuration

This submenu displays the following CPU information as detected by the BIOS. It also allows the user to configure CPU settings.

►Processor 0/Processor 1

This submenu displays the following information of the CPU installed in Socket 0, and Socket 1.

- Processor Socket
- Processor ID
- Processor Frequency
- Processor Max Ratio
- Processor Min Ratio
- Microcode Revision
- L1 Cache RAM
- L2 Cache RAM
- L3 Cache RAM
- Processor 0 Version
- Processor 1 Version

Clock Spread Spectrum

Select Enable to allow the BIOS to attempt to reduce the level of Electromagnetic Interference caused by the components whenever needed. The options are **Disable** and Enable.

Hyper-Threading (All)

Select Enable to support Intel's Hyper-threading Technology to enhance CPU performance. The options are **Enable** and Disable.

Cores Enabled

Use this item to set the number of CPU cores to be enabled in your system. Enter "0" to enable all cores. The default setting is **0**.

Execute-Disable Bit (Available if supported by the OS & the CPU)

Select Enable for Execute Disable Bit Technology support, which will allow the processor to designate areas in the system memory where an application code can execute and where it cannot, thus preventing a worm or a virus from flooding illegal codes to overwhelm the processor or damage the system during an attack.

The options are **Enable** and Disable. (Refer to Intel and Microsoft websites for more information.)

PPIN Control

Select Unlock/Enable to use the Protected-Processor Inventory Number (PPIN) in the system. The options are **Unlock/Enable** and Unlock/Disable.

Hardware Prefetcher (Available when supported by the CPU)

If set to Enable, the hardware prefetcher will prefetch streams of data and instructions from the main memory to the L2 cache to improve CPU performance. The options are Disable and **Enable**.

Adjacent Cache Line Prefetch (Available when supported by the CPU)

Select Enable for the CPU to prefetch both cache lines for 128 bytes as comprised. Select Disable for the CPU to prefetch both cache lines for 64 bytes. The options are Disable and **Enable**.

Note: Please reboot the system for changes on this setting to take effect. Please refer to Intel's web site for detailed information.

DCU (Data Cache Unit) Streamer Prefetcher (Available when supported by the CPU)

If set to Enable, the DCU Streamer Prefetcher will prefetch data streams from the cache memory to the DCU to speed up data accessing and processing to enhance CPU performance. The options are Disable and **Enable**.

DCU IP Prefetcher

If set to Enable, the IP prefetcher in the DCU (Data Cache Unit) will prefetch IP addresses to improve network connectivity and system performance. The options are **Enable** and Disable.

Direct Cache Access (DCA)

Select Enable to use Intel DCA (Direct Cache Access) Technology to improve the efficiency of data transferring and accessing. The options are **Enable** and Disable.

X2 APIC (Advanced Programmable Interrupt Controller)

Based on Intel's Hyper-Threading architecture, each logical processor (thread) is assigned 256 APIC IDs (APIDs) in 8-bit bandwidth. When this feature is set to Enable, the APIC ID will expand from 8 bits (X2) to 16 bits to provide 512 APIDs to each thread for CPU performance enhancement. The options are **Disable** and Enable.

AES-NI

Select Enable to use the Intel Advanced Encryption Standard (AES) New Instructions (NI) to ensure data security. The options are **Enable** and Disable.

Intel Virtualization Technology (Available when supported by the CPU)

Select Enable to support Intel Virtualization Technology, which will allow one platform to run multiple operating systems and applications in independent partitions, creating multiple "virtual" systems in one physical computer. The options are **Enable** and Disable.

Note: If there is a change to this setting, you will need to power off and restart the system for the change to take effect. Please refer to Intel's website for detailed information.)

► Advanced Power Management Configuration

Advanced Power Management Configuration

Power Technology

Select Energy Efficient to support power-saving mode. Select Custom to customize system power settings. Select Disable to disable power-saving settings. The options are Disable, **Energy Efficient**, and Custom.

**If the option is set to Custom or Energy Efficient, the following items will display:*

Energy Performance Tuning (Available when Power Technology is set to Custom or Energy Efficient)

Select Enable for energy-performance tuning support to enhance energy efficiency, which might compromise system performance. The options are Enable and **Disable**.

Energy Efficiency Turbo (Available when Power Technology is set to Custom or Energy Efficient)

Select Enable for the system to operate at turbo mode with reduced power consumption so that your machine can achieve maximum system performance with the maximum power efficiency possible. The options are **Enable** and Disable.

**If the option is set to Custom, the following items will display:*

► CPU P State Control (Available when Power Technology is set to Custom)

EIST (P-states)

EIST (Enhanced Intel SpeedStep Technology) allows the system to automatically adjust processor voltage and core frequency to reduce power consumption and heat dissipation. The options are Disable and **Enable**.

Turbo Mode

Select Enable to use the Turbo Mode to boost system performance. The options are Disable and **Enable**.

P-state Coordination

This item is used to change the P-state (Power-Performance State) coordination type. P-state is also known as "SpeedStep" for Intel processors. Select HW_ALL to change the P-state coordination type for hardware components only. Select SW_ALL to change the P-state coordination type for all software installed in the system. Select SW_ANY to change the P-state coordination type for a software program in the system. The options are **HW_ALL**, **SW_ALL**, and **SW_ANY**.

► CPU C State Control (Available when Power Technology is set to Custom)

Package C State limit

Use this item to set the limit on the C-State package register. The options are C0/ C1 state, C2 state, C6(non Retention) state, **C6 (Retention) state**, and No Limit.

CPU C3 Report

Select Enable to allow the BIOS to report the CPU C3 state (ACPI C2) to the operating system. During the CPU C3 state, the CPU clock generator is turned off. The options are **Disable** and Enable.

CPU C6 Report (Available when Power Technology is set to Custom)

Select Enable to allow the BIOS to report the CPU C6 state (ACPI C3) to the operating system. During the CPU C6 state, power to all cache is turned off. The options are Disable and **Enable**.

Enhanced Halt State (C1E)

Select Enable to use the "Enhanced Halt State" feature, which will significantly reduce the CPU's power consumption by reducing the CPU's clock cycle and voltage during a "Halt State." The options are Disable and **Enable**.

▶ CPU T State Control (Available when Power Technology is set to Custom)

ACPI (Advanced Configuration Power Interface) T-States

If this item is set to Enable, CPU throttling will be supported by the operating system to reduce power consumption. The options are Disable and **Enable**.

▶ Chipset Configuration

▶ North Bridge

This feature is used to configure Intel North Bridge settings.

▶ IIO (Integrated IO) Configuration

EV DFX (Device Function On-Hide) Features

When this item is set to Enable, the EV_DFX Lock Bits that are located on a processor will always remain clear during electric tuning. The options are **Disable** and Enable.

▶ IIO0 Configuration

IOU2 (IIO PCIe Port 1)

This feature allows the user to set the bus speed between the IOU2 and the PCI-Exp port specified above. The options are x4x4, x8, and **Auto**.

IOU0 (IIO PCIe Port 2)

This feature allows the user to set the bus speed between the IOU0 and the PCI-Exp port specified above. The options are x4x4x4x4, x4x4x8, x8x4x4, x8x8, x16, and **Auto**.

IOU1 (IIO PCIe Port 3)

This feature allows the user to set the bus speed between the IOU1 and the PCI-Exp port specified above. The options are x4x4x4x4, x4x4x8, x8x4x4, x8x8, x16, and **Auto**.

No PCIe Port Active ECO

Use this feature to select a workaround setting to implement the engineering-change order (ECO) on the system when the PCI ports specified by the user are not active. The options are **PCU Squelch exit ignore option** and Reset the SQ FLOP by CSR option.

► Socket 0 PCIeD00F0-Port 0/DMI

Use the items below to configure the PCI-E settings for a PCI-E port specified by the user.

Link Speed

Use this item to select the PCI-E link speed for the PCI-E port specified by the user. The options for CPU-PCH DMI port and are GEN1 (2.5 GT/s), GEN2 (5 GT/s), and **Auto**. The options for Onboard LAN port, CPU1 Slot1 x8 port, and CPU1 Slot2 x16 port are GEN1 (2.5 GT/s), GEN2 (5 GT/s), GEN3 (8 GT/s), and **Auto**.

PCI-E Port DeEmphasis

Use this item to select the De-Emphasis control setting for a PCI-E port specified by the user. The options are **-6.0 dB** and -3.5 dB.

The following items will display:

- PCI-E Port Link Status
- PCI-E Port Link Max
- PCI-E Port Link Speed

PCI-E Port L0s Exit Latency

Use this feature to set the length of time required for the port specified by the user to complete the transition from L0s to L0. The default setting is **4uS - 8uS**.

PCI-E Port L1 Exit Latency

Use this feature to set the length of time required for the port specified by the user to complete the transition from L1 to L0. The default setting is <1uS, 1uS - 2uS, 2uS - 4uS, 4uS - 8uS, **8uS - 16uS**, 16uS - 32uS, 32uS - 64uS, and >64uS.

Fatal Err (Error) Over

Select Enable to force fatal error prorogation to the IIO core error logic for the port specified by the user. The options are **Disable** and Enable.

Non-Fatal Err (Error) Over

Select Enable to force non-fatal error prorogation to the IIO core error logic for the port specified by the user. The options are **Disable** and Enable.

Corr Err (Correctable Error) Over

Select Enable to force correctable error prorogation to the IIO core error logic for the port specified by the user. The options are **Disable** and Enable.

L0s Support

When this item is set to Disable, IIO will not put its transmitter in the L0s state. The default setting is **Disable**.

►Socket 0 PCIeD01F0 - Port 1A/Socket 0 PCIeD02F0 - Port 2A/Socket 0 PCIeD03F2 - Port 3A

PCI-E Port

Select Enable to enable the PCI-E port specified by the user. The options are **Auto**, Enable, and Disable.

Hot Plug Capable

Select Enable to enable hot-plugging support for the PCI-E port specified by the user to allow the user to replace the device installed on the port without shutting down the system. The options are **Disable** and Enable.

PCI-E Port Link

Select Disable to disable the link that is not involved in training activities, but its CFG is still active. The options are **Enable** and Disable.

Link Speed

Use this item to select the link speed for the PCI-E port specified by the user. The options are **Auto**, GEN1 (2.5 GT/s), GEN2 (5 GT/s), and GEN3 (8 GT/s).

PCI-E Port DeEmphasis

Use this item to select the De-Emphasis control setting for a PCI-E port specified by the user. The options are **-6.0 dB** and -3.5 dB.

The following items will display:

- PCI-E Port Link Status
- PCI-E Port Link Max
- PCI-E Port Link Speed

PCI-E Port L0s Exit Latency

Use this feature to set the length of time required for the port specified by the user to complete the transition from L0s to L0. The default setting is **4uS - 8uS**.

PCI-E Port L1 Exit Latency

Use this feature to set the length of time required for the port specified by the user to complete the transition from L1 to L0. The default setting is <1uS, 1uS - 2uS, 2uS - 4uS, 4uS - 8uS, **8uS - 16uS**, 16uS - 32uS, 32uS - 64uS, and >64uS.

Fatal Err (Error) Over

Select Enable to force fatal error prorogation to the IIO core error logic for the port specified by the user. The options are **Disable** and Enable.

Non-Fatal Err (Error) Over

Select Enable to force non-fatal error prorogation to the IIO core error logic for the port specified by the user. The options are **Disable** and Enable.

Corr Err (Correctable Error) Over

Select Enable to force correctable error prorogation to the IIO core error logic for the port specified by the user. The options are **Disable** and Enable.

L0s Support

When this item is set to Disable, IIO will not put its transmitter in the L0s state. The default option is **Disable**.

PM ACPI Support

Select Enable to generate an _HPGPE message on a PM ACPI event. Select Disable to generate an MSI message. The options are **Disable** and Enable.

Gen3 (Generation 3) Eq (Equalization) Mode

Use this item to set the "Adaptive Equalization" mode for PCI-E Generation 3 devices. The options are **Auto**; Enable Phase 0, 1, 2, 3; Disable Phase 0, 1, 2, 3; Enable Phase 1 Only; Enable Phase 0, 1 Only; Advanced; and Enable MMM Offset West.

Gen3 (Generation 3) Spec (Specifics) Mode

Use this item to set the Specifics mode for PCI-E Generation 3 devices. The options are **Auto**, 0.70 July, 0.70 Sept and 0.71 Sept.

Gen3 (Generation 3) Phase2 Mode

Use this item to set the PCI-E Generation 3 Phase 2 mode. The options are **Hardware Adaptive** and Manual.

Gen3 (Generation 3) DN TX Preset

Use this item to set the Preset mode for PCI-E Gen3 downstream transactions (from the master device to a slave device). The options are **Auto**, P0 (-6.0/0.0 dB), P1 (-3.5/0.0 dB), P2 (-4.5/0.0 dB), P3 (-2.5/0.0 dB), P4 (0.0/0.0 dB), P5 (0.0/2.0 dB), P6 (0.0/2.5 dB), P7 (-6.0 /3.5 dB), P8 (-3.5/3.5 dB), and P9 (0.0/3.5 dB).

Gen3 (Generation 3) DN RX Preset Hint

Use this item to set the Preset Hint mode for PCI-E Gen3 downstream reception (from a slave device to the master device). The options are **Auto**, P0 (-6.0 dB), P1 (-7.0 dB), P2 (-8.0 dB), P3 (-9.0 dB), P4 (-10.0 dB), P5 (-11.0 dB), and P6 (-12.0 dB).

Gen3 (Generation 3) Up TX Preset

Use this item to set the Preset mode for PCI-E Gen3 upstream transactions (from a slave device to the master device).The options are **Auto**, P0 (-6.0/0.0 dB), P1 (-3.5/0.0 dB), P2 (-4.5/0.0 dB), P3 (-2.5/0.0 dB), P4 (0.0/0.0 dB), P5 (0.0/2.0 dB), P6 (0.0/2.5 dB), P7 (-6.0/3.5 dB), P8 (-3.5/3.5 dB), and P9 (0.0/3.5 dB).

Non-Transparent Bridge PCIe Port Definition (Port 3A only)

Select Transparent Bridge to configure the device installed on a PCI slot specified by the user as a transparent bridge (TB) device. Select NTB (Non-Transparent Bridge) to NTB to configure the device installed on a PCI slot specified by the user as a non-transparent bridge (NTB) device used to connect to another NTB device. The options are **Transparent Bridge**, NTB to NTB, and NTB to RP.

Hide Port?

Select Yes to hide the PCI-E port specified from the OS. The options are **No** and Yes.

► IIO1 Configuration

IOU2 (IIO PCIe Port 1)

This feature allows the user to set the bus speed between the IOU2 and the PCI-Exp port specified above. The options are x4x4, x8, and **Auto**.

IOU0 (IIO PCIe Port 2)

This feature allows the user to set the bus speed between the IOU0 and the PCI-Exp port specified above. The options are x4x4x4x4, x4x4x8, x8x4x4, x8x8, x16, and **Auto**.

IOU1 (IIO PCIE Port 3)

This feature allows the user to set the bus speed between the IOU1 and the PCI-Exp port specified above. The options are x4x4x4x4, x4x4x8, x8x4x4, x8x8, x16, and **Auto**.

No PCIe Port Active ECO

Use this feature to select a workaround setting to implement the engineering-change order (ECO) on the system when the PCI ports specified by the user are not active. The options are **PCU Squelch exit ignore option** and **Reset the SQ FLOP by CSR option**.

►Socket 1 PCIeD00F0-Port 0/DMI/Socket 1 PCIeD01F0 - Port 1A/Socket 1 PCIeD02F0 - Port 2A/Socket 1 PCIeD03F0 - Port 3A

PCI-E Port

Select **Enable** to enable the PCI-E port specified by the user. The options are **Auto**, **Enable**, and **Disable**.

Hot Plug Capable

Select **Enable** to enable hot-plugging support for the PCI-E port specified by the user to allow the user to replace the device installed on the port without shutting down the system. The options are **Disable** and **Enable**.

PCI-E Port Link

Select **Disable** to disable the link that is not involved in training activities, but its CFG is still active. The options are **Enable** and **Disable**.

Link Speed

Use this item to select the link speed for the PCI-E port specified by the user. The options are **Auto**, **GEN1 (2.5 GT/s)**, **GEN2 (5 GT/s)**, and **GEN3 (8 GT/s)**.

PCI-E Port DeEmphasis

Use this item to select the De-Emphasis control setting for a PCI-E port specified by the user. The options are **-6.0 dB** and **-3.5 dB**.

The following items will display:

- PCI-E Port Link Status
- PCI-E Port Link Max
- PCI-E Port Link Speed

PCI-E Port L0s Exit Latency

Use this feature to set the length of time required for the port specified by the user to complete the transition from L0s to L0. The default setting is **4uS - 8uS**.

PCI-E Port L1 Exit Latency

Use this feature to set the length of time required for the port specified by the user to complete the transition from L1 to L0. The default setting is <1uS, 1uS - 2uS, 2uS - 4uS, 4uS - 8uS, **8uS - 16uS**, 16uS - 32uS, 32uS - 64uS, and >64uS.

Fatal Err (Error) Over

Select Enable to force fatal error prorogation to the IIO core error logic for the port specified by the user. The options are **Disable** and Enable.

Non-Fatal Err (Error) Over

Select Enable to force non-fatal error prorogation to the IIO core error logic for the port specified by the user. The options are **Disable** and Enable.

Corr Err (Correctable Error) Over

Select Enable to force correctable error prorogation to the IIO core error logic for the port specified by the user. The options are **Disable** and Enable.

L0s Support

When this item is set to Disable, IIO will not put its transmitter in the L0s state. The default option is **Disable**.

PM ACPI Mode

Select Enable to generate an _HPGPE message on a PM ACPI event. Select Disable to generate an MSI message. The options are **Disable** and Enable.

Gen3 (Generation 3) Eq (Equalization) Mode

Use this item to set the "Adaptive Equalization" mode for PCI-E Generation 3 devices. The options are **Auto**; Enable Phase 0, 1, 2, 3; Disable Phase 0, 1, 2, 3; Enable Phase 1 Only; Enable Phase 0, 1 Only; Advanced; and Enable MMM Offset West.

Gen3 (Generation 3) Spec (Specifics) Mode

Use this item to set the Specifics mode for PCI-E Generation 3 devices. The options are **Auto**, 0.70 July, 0.70 Sept, and 0.71 Sept.

Gen3 (Generation 3) Phase2 Mode

Use this item to set the PCI-E Generation 3 Phase 2 mode. The options are **Hardware Adaptive** and Manual.

Gen3 (Generation 3) DN TX Preset

Use this item to set the Preset mode for PCI-E Gen3 downstream transactions (from the master device to a slave device). The options are **Auto**, P0 (-6.0/0.0 dB), P1 (-3.5/0.0 dB), P2 (-4.5/0.0 dB), P3 (-2.5/0.0 dB), P4 (0.0/0.0 dB), P5 (0.0/2.0 dB), P6 (0.0/2.5 dB), P7 (-6.0/3.5 dB), P8 (-3.5/3.5 dB), and P9 (0.0/3.5 dB).

Gen3 (Generation 3) DN RX Preset Hint

Use this item to set the Preset Hint mode for PCI-E Gen3 downstream reception (from a slave device to the master device). The options are **Auto**, P0 (-6.0 dB), P1 (-7.0 dB), P2 (-8.0 dB), P3 (-9.0 dB), P4 (-10.0 dB), P5 (-11.0 dB), and P6 (-12.0 dB).

Gen3 (Generation 3) Up TX Preset

Use this item to set the Preset mode for PCI-E Gen3 upstream transactions (from a slave device to the master device). The options are **Auto**, P0 (-6.0/0.0 dB), P1 (-3.5/0.0 dB), P2 (-4.5/0.0 dB), P3 (-2.5/0.0 dB), P4 (0.0/0.0 dB), P5 (0.0/2.0 dB), P6 (0.0/2.5 dB), P7 (-6.0/3.5 dB), P8 (-3.5/3.5 dB), and P9 (0.0/3.5 dB).

Non-Transparent Bridge PCIe Port Definition (Port 3A only)

Select Transparent Bridge to configure the device installed on a PCI slot specified by the user as a transparent bridge (TB) device. Select NTB (Non-Transparent Bridge) to NTB to configure the device installed on a PCI slot specified by the user as a non-transparent bridge (NTB) device used to connect to another NTB device. The options are **Transparent Bridge**, NTB to NTB, and NTB to RP.

Hide Port?

Select Yes to hide the PCI-E port specified from the OS. The options are **No** and Yes.

► IOAT Configuration**Enable IOAT**

Select Enable to enable Intel I/OAT (I/O Acceleration Technology), which significantly reduces CPU overhead by leveraging CPU architectural improvements and freeing the system resource for other tasks. The options are Disable and **Enable**.

No Snoop

Select Enable to support no-snoop mode for each CB device. The options are **Disable** and Enable.

Relaxed Ordering

Select Enable for relaxed ordering support, which will allow certain transactions to be processed and completed prior to other transactions that have already been queued and that violate the strict ordering rules of PCI processing. The options are **Disable** and Enable.

► Intel VT for Directed I/O (VT-d)

Intel® VT for Directed I/O (VT-d)

Select Enable to enable Intel Virtualization Technology support for Direct I/O VT-d by reporting the I/O device assignments to the VMM (Virtual Machine Monitor) through the DMAR ACPI Tables. This feature offers fully-protected I/O resource sharing across Intel platforms, providing greater reliability, security and availability in networking and data-sharing. The options are **Enable** and Disable.

Interrupt Remapping

Select Enable to support Interrupt Remapping to enhance system performance. The options are **Enable** and Disable.

► QPI (Quick Path Interconnect) Configuration

QPI Status

The following information will display:

- Number of CPU
- Number of IIO
- Current QPI Link Speed
- Current QPI Link Frequency
- QPI Global MMIO Low Base/Limit
- QPI Global MMIO High Base/Limit
- QPI PCI-E Configuration Base/Siz (Size)

Link Frequency Select

Use this feature to select the desired frequency for QPI Link connections. The options are 6.4GB/s, 8.0GB/s, 9.6GB/s, **Auto**, and Auto Limited.

Link L0p Enable

Select Enable for Link L0p support. The options are Disable and **Enable**.

Link L1 Enable

Select Enable for Link L1 support. The options are Disable and **Enable**.

Early Snoop

Select Enable to support Early Snoop mode for the QPI link. The options are Disable, Enable, and **Auto**.

Isoc

Select Enable to enable Isochronous support to meet QoS (Quality of Service) requirements. This feature is especially important for virtualization technology. The options are **Disable** and Enable.

► Memory Configuration**Enforce POR**

Select Enable to enforce POR restrictions on DDR4 frequency and voltage programming. The options are **Enabled** and Disabled.

Memory Frequency

Use this item to set the maximum memory frequency for onboard memory modules. The options are **Auto**, 1333, 1400, 1600, 1800, 1867, 2000, 2133, 2200, 2400, 2600, 2667, 2800, 2993, 3000, 3200, and Reserved.

Data Scrambling

Select Enabled to enable data scrambling to enhance system performance and data integrity. The options are **Auto**, Disabled, and Enabled.

Enable ADR

Use this item to configure Automatic Diagnostic Repository (ADR) settings to enhance memory performance. The options are **Disabled** and Enabled.

DRAM RAPL (Running Average Power Limit) Baseline

Use this item to set the run-time power-limit baseline for the DRAM modules. The options are Disable, DRAM RAPL Mode 0, and **DRAM RAPL Mode 1**.

Set Throttling Mode

Throttling improves reliability and reduces power consumption in processors via automatic voltage control during processor idle states. The options are Disabled and **CLTT** (Closed Loop Thermal Throttling).

Socket Interleave Below 4GB

Select Enabled for the memory above the 4G Address space to be split between two sockets. The options are **Disable** and Enable.

A7 Mode

Select Enabled to support the A7 (Addressing) mode to improve memory performance. The options are Disable and **Enable**.

► DIMM Information

This item displays the status of a DIMM module as detected by the BIOS.

P1-DIMMA1-A3/P1-DIMMB1-B3/P1-DIMMC1-C3/P1-DIMMD1-D3/P2-DIMME1-E3/P2-DIMMF1-F3/P2-DIMMG1-G3/P2-DIMMH1-H3

► Memory RAS (Reliability/Availability/Serviceability) Configuration

Use this submenu to configure the following Memory RAS settings.

RAS Mode

When Disable is selected, RAS is not supported. When Mirror is selected, the motherboard maintains two identical copies of all data in memory for data backup. When Lockstep is selected, the motherboard uses two areas of memory to run the same set of operations in parallel to boost performance. The options are **Disable**, Mirror, and Lockstep Mode.

Memory Rank Sparing

Select Enable to enable memory-sparing support for memory ranks to improve memory performance. The options are **Disabled** and Enabled.

Patrol Scrub

Patrol Scrubbing is a process that allows the CPU to correct correctable memory errors detected on a memory module and send the correction to the requestor (the original source). When this item is set to Enable, the PCH (Platform Control Hub) will read and write-back one cache line every 16K cycles if there is no delay caused by internal processing. By using this method, roughly 64 GB of

memory behind the PCH will be scrubbed every day. The options are **Disable** and **Enable**.

Patrol Scrub Interval

This feature allows you to decide how many hours the system should wait before the next complete patrol scrub is performed. Use the keyboard to enter a value from 0-24. The default setting is **24**.

Demand Scrub

Demand Scrubbing is a process that allows the CPU to correct correctable memory errors found on a memory module. When the CPU or I/O issues a demand-read command, and the read data from memory turns out to be a correctable error, the error is corrected and sent to the requestor (the original source). Memory is updated as well. Select **Enable** to use Demand Scrubbing for ECC memory correction. The options are **Disable** and **Enable**.

Device Tagging

Select **Enable** to support device tagging. The options are **Disable** and **Enable**.

►South Bridge Configuration

The following South Bridge information will display:

►USB Configuration

- USB Module Version
- USB Devices

Legacy USB Support

Select **Enabled** to support onboard legacy USB devices. Select **Auto** to disable legacy support if there are no legacy USB devices present. Select **Disable** to have all USB devices available for EFI applications only. The options are **Enabled**, **Disabled**, and **Auto**.

XHCI (Extensible Host Controller Interface) Hand-Off

This is a work-around solution for operating systems that do not support XHCI (Extensible Host Controller Interface) hand-off. The XHCI ownership change should be claimed by the XHCI driver. The settings are **Enabled** and **Disabled**.

EHCI Hand-Off

This item is for operating systems that do not support Enhanced Host Controller Interface (EHCI) hand-off. When this item is enabled, EHCI ownership change will be claimed by the EHCI driver. The settings are **Disabled** and **Enabled**.

Port 60/64 Emulation

Select **Enabled** for I/O port 60h/64h emulation support which will provide complete USB keyboard legacy support for the operating system that does not support Legacy USB devices. The options are **Disabled** and **Enabled**.

USB 3.0 Support

Select **Enabled** for USB 3.0 support. The options are **Smart Auto**, **Auto**, **Enabled**, and **Disabled**.

►SATA Configuration

When this submenu is selected, AMI BIOS automatically detects the presence of the SATA devices and displays the following items:

SATA Controller

This item enables or disables the onboard SATA controller supported by the Intel PCH chip. The options are **Disabled** and **Enabled**.

Configure SATA as

Select **IDE** to configure a SATA drive specified by the user as an IDE drive. Select **AHCI** to configure a SATA drive specified by the user as an AHCI drive. Select **RAID** to configure a SATA drive specified by the user as a RAID drive. The options are **IDE**, **AHCI**, and **RAID**.

**If the item above "Configure SATA as" is set to AHCI, the following items will display:*

Support Aggressive Link Power Management

When this item is set to **Enabled**, the SATA AHCI controller manages the power usage of the SATA link. The controller will put the link to a low power state when the I/O is inactive for an extended period of time, and the power state will return to normal when the I/O becomes active. The options are **Disabled** and **Enabled**.

SATA Port 0-Port 5

This item displays the information detected on the installed SATA drive on the particular SATA port.

- Model number of drive and capacity
- Software Preserve Support

SATA Port 0-Port 5

Select Enabled to enable a SATA port specified by the user. The options are Disabled and **Enabled**.

SATA Port 0-Port 5 Hot Plug

Select Enabled to enable hot-plugging support for a port specified by the user, which will allow the user to replace a SATA disk drive installed on this port without shutting down the system. The options are Disabled and **Enabled**.

SATA Port 0-Port 5 Spin Up Device

On an edge detect from 0 to 1, select Enabled to allow the PCH to initialize the device. The options are **Disabled** and Enabled.

SATA Port 0-Port 5 SATA Device Type

Use this item to specify if the SATA port specified by the user should be connected to a Solid State drive or a Hard Disk Drive. The options are **Hard Disk Drive** and Solid State Drive.

**If the item above "Configure SATA as" is set to IDE, the following items will display:*

Serial ATA Port 0-Port 5

This item indicates that a SATA port specified by the user is installed (present) or not.

SATA Port 0-Port 5 SATA Device Type (Available when a SATA port is detected)

Use this item to specify if the SATA port specified by the user should be connected to a Solid State drive or a Hard Disk Drive. The options are **Hard Disk Drive** and Solid State Drive.

**If the item above "Configure SATA as" is set to RAID, the following items will display:*

Support Aggressive Link Power Management

When this item is set to Enabled, the SATA AHCI controller manages the power usage of the SATA link. The controller will put the link to a low power state when

the I/O is inactive for an extended period of time, and the power state will return to normal when the I/O becomes active. The options are Disabled and **Enabled**.

SATA RAID Option ROM/UEFI Driver

Select EFI to load the EFI driver for system boot. Select Legacy to load a legacy driver for system boot. The options are **Legacy**, EFI, and Disabled.

SATA/sSATA RAID Boot Select

Select SATA Controller to boot the system from a SATA RAID device. Select sSATA Controller to boot the system from a S-SATA RAID device. Select Both to boot the system either from a SATA RAID device or from an sSATA RAID device. Please note that the option-Both is not supported by the Windows Server 2012/R2 OS. The options are None, SATA Controller, **sSATA Controller**, and Both.

Serial ATA Port 0-Port 5

This item displays the information detected on the installed SATA drives on the particular SATA port.

- Model number of drive and capacity
- Software Preserve Support

Serial ATA Port 0-Port 5

Select Enabled to enable a SATA port specified by the user. The options are Disabled and **Enabled**.

Serial ATA Port 0Port 5 Hot Plug

Select Enabled to enable hot-plugging support for a port specified by the user, which will allow the user to replace a SATA disk drive installed on this port without shutting down the system. The options are Disabled and **Enabled**.

Serial ATA Port 0-Port 5 Spin Up Device

On an edge detect from 0 to 1, set this item to allow the PCH to start a COMRESET initialization to the device. The options are **Disabled** and Enabled.

Serial ATA Port 0-Port 5 SATA Device Type

Use this item to specify if the SATA port specified by the user should be connected to a Solid State drive or a Hard Disk Drive. The options are **Hard Disk Drive** and Solid State Drive.

►sSATA Configuration

When this submenu is selected, AMI BIOS automatically detects the presence of the SATA devices that are supported by the PCH-sSATA controller and displays the following items:

sSATA Controller

This item enables or disables the onboard SATA controller supported by the Intel PCH-sSATA controller. The options are **Enabled** and Disabled.

Configure sSATA as

Select IDE to configure an sSATA drive specified by the user as an IDE drive. Select AHCI to configure an sSATA drive specified by the user as an AHCI drive. Select RAID to configure an sSATA drive specified by the user as a RAID drive. The options are IDE, **AHCI**, and RAID.

**If the item above "Configure sSATA as" is set to AHCI, the following items will display:*

Support Aggressive Link Power Management

When this item is set to Enabled, the SATA AHCI controller manages the power usage of the SATA link. The controller will put the link to a low power state when the I/O is inactive for an extended period of time, and the power state will return to normal when the I/O becomes active. The options are Disabled and **Enabled**.

sSATA Port 0-Port 3

This item displays the information detected on the installed on the sSATA port. specified by the user.

- Model number of drive and capacity
- Software Preserve Support

sSATA Port 0-Port 3

Select Enabled to enable an sSATA port specified by the user. The options are Disabled and Enabled.

sSATA Port 0-Port 3 Hot Plug

Select Enabled to enable hot-plugging support for a port specified by the user, which will allow the user to replace a sSATA disk drive installed on this port without shutting down the system. The options are Disabled and **Enabled**.

sSATA Port 0-Port 3 Spin Up Device

On an edge detect from 0 to 1, set this item to allow the PCH to start a COMRESET initialization to the device. The options are **Disabled** and Enabled.

sSATA Port 0-Port 3 sSATA Device Type

Use this item to specify if the sSATA port specified by the user should be connected to a Solid State drive or a Hard Disk Drive. The options are **Hard Disk Drive** and Solid State Drive.

**If the item above "Configure sSATA as" is set to IDE, the following items will display:*

sSATA Port 0-Port 3

This item indicates that an sSATA port specified by the user is installed (present) or not.

sSATA Port 0 ~ Port 3 sSATA Device Type (Available when a SATA port is detected)

Use this item to specify if the sSATA port specified by the user should be connected to a Solid State drive or a Hard Disk Drive. The options are **Hard Disk Drive** and Solid State Drive.

**If the item above "Configure sSATA as" is set to RAID, the following items will display:*

Support Aggressive Link Power Management

When this item is set to Enabled, the SATA AHCI controller manages the power usage of the SATA link. The controller will put the link to a low power state when the I/O is inactive for an extended period of time, and the power state will return to normal when the I/O becomes active. The options are Disabled and **Enabled**.

sSATA RAID Option ROM/UEFI Driver

Select EFI to load the EFI driver for system boot. Select Legacy to load a legacy driver for system boot. The options are **Legacy**, EFI, and Disabled.

SATA/sSATA RAID Boot Select

Select SATA Controller to use a device supported by the SATA connector for system boot. Select sSATA Controller to use a device supported by the sSATA connector for system boot. The options are None, SATA Controller, **sSATA Controller**, and Both.

sSATA Port 0-Port 3

This item displays the information detected on the installed sSATA drives on the particular sSATA port.

- Model number of drive and capacity
- Software Preserve Support

sSATA Port 0-Port 3

Select Enabled to enable an sSATA port specified by the user. The options are Disabled and Enabled.

sSATA Port 0-Port 3 Hot Plug

This feature designates this port for hot plugging. Set this item to Enabled for hot-plugging support, which will allow the user to replace an sSATA drive without shutting down the system. The options are Disabled and **Enabled**.

sSATA Port 0-Port 3 Spin Up Device

On an edge detect from 0 to 1, set this item to allow the PCH to start a COMRESET initialization to the device. The options are **Disabled** and Enabled.

sSATA Port 0-Port 3 sSATA Device Type

Use this item to specify if the sSATA port specified by the user should be connected to a Solid State drive or a Hard Disk Drive. The options are **Hard Disk Drive** and Solid State Drive.

► Server ME (Management Engine) Configuration

This feature displays the following system ME configuration settings.

- General ME Configuration
- Operational Firmware Version
- Recovery Firmware Version
- ME Firmware Features
- ME Firmware Status #1
- ME Firmware Status #2
 - Current State
 - Error Code

Altitude

This feature indicates the altitude of the platform this machine is located above the sea level. The value is shown in meters. If the value is unknown, enter the number "80000000."

MCTP (Management Component Transport Protocol) Bus Owner

This feature indicates the location of the MCTP Bus owner. Enter 0s to all fields to disable the MCTP Bus owner.

►PCIe/PCI/PnP Configuration

The following PCI information will be displayed:

PCI Latency Timer

Use this item to configure the PCI latency timer for a device installed on a PCI bus. Select 32 to set the PCI latency timer to 32 PCI clock cycles. The options are **32**, 64, 96, 128, 160, 192, 224, and 248 (PCI Bus Clocks).

PERR# Generation

Select Enabled to allow a PCI device to generate a PERR (PCI/PCI-E Parity Error) number for a PCI bus error event. The options are **Disabled** and Enabled.

SERR# Generation

Select Enabled to allow a PCI device to generate an SERR (System Error) number for a PCI bus error event. The options are **Disabled** and Enabled.

PCI PERR/SERR Support

Select Enabled to allow a PCI device to generate a PERR (PCI/PCI-E Parity Error) or an SERR (System Error) number for a PCI bus error event. The options are **Disabled** and Enabled.

Above 4G Decoding (Available if the system supports 64-bit PCI decoding)

Select Enabled to decode a PCI device that supports 64-bit in the space above 4G Address. The options are Disabled and **Enabled**.

SR-IOV (Available if the system supports Single-Root Virtualization)

Select Enabled for Single-Root IO Virtualization support. The options are **Disabled** and Enabled.

Maximum Payload

Select Auto for the system BIOS to automatically set the maximum payload value for a PCI-E device to enhance system performance. The options are **Auto**, 128 Bytes, 256 Bytes, 512 Bytes, 1024 Bytes, 2048 Bytes, and 4096 Bytes.

Maximum Read Request

Select Auto for the system BIOS to automatically set the maximum size for a read request for a PCI-E device to enhance system performance. The options are **Auto**, 128 Bytes, 256 Bytes, 512 Bytes, 1024 Bytes, 2048 Bytes, and 4096 Bytes.

ASPM Support

Use this item to set the Active State Power Management (ASPM) level for a PCI-E device. Select Auto for the system BIOS to automatically set the ASPM level based on the system configuration. Select Disabled to disable ASPM support. The options are **Disabled** and Auto.

Caution: Enabling ASPM support may cause some PCI-E devices to fail!

MMIOHBase

Use this item to select the base memory size according to memory-address mapping for the PCH. The base memory size must be between 4032G to 4078G. The options are **56T**, 48T, 24T, 2T, 512G, and 256G.

MMIO High Size

Use this item to select the high memory size according to memory-address mapping for the PCH. The options are **256G**, 128G, 512G, and 1024G.

PC Devices Option ROM Settings

RSC-G-6/CPU2 Slot1 PCI-E x16 OPROM

RSC-G-6/CPU2 Slot2 PCI-E x16 OPROM

RSC-G-6/CPU1 Slot3 PCI-E x16 OPROM

RSC-GR-6/CPU1 Slot4 PCI-E x16 OPROM

RSC-GR-A88 upper/CPU1 Slot5 PCI-E x8 OPROM

RSC-GR-A88 lower/CPU2 Slot6 PCI-E x8 OPROM

Select Enabled to enable Option ROM support to boot the computer using a device installed on the slot specified by the user. The options are Disabled, **Legacy** and EFI.

Onboard Video Option ROM

Use this option to select the type of device installed in the onboard video device used for system boot. The options are Disabled, **Legacy**, and EFI.

VGA Priority

Use this item to select the graphics device to be used as the primary video display for system boot. The options are **Onboard** and Offboard.

Onboard LAN Option ROM Type

Select Legacy to boot the computer using a Legacy device installed on the motherboard. The options are **Legacy** and EFI.

Onboard LAN 1 Option ROM/Onboard LAN 2 Option ROM

Select iSCSI to use the iSCSI Option ROM to boot the computer using an iSCSI device installed in a LAN port specified. Select PXE (Preboot Execution Environment) to boot the computer using a PXE device installed in a LAN port specified. Select Disabled to prevent system boot using a device installed in a LAN port. The options for Onboard LAN1 Option ROM are **PXE**, iSCSI, FCoE, and Disabled. The options for Onboard LAN2 Option ROM are PXE and **Disabled**.

► Super IO Configuration

Super IO Chip AST2400

► Serial Port 1 Configuration/Serial Port 2 Configuration

Serial Port 1/Serial Port 2

Select Enabled to enable the onboard serial port specified by the user. The options are Disabled and **Enabled**.

Device Settings

This item displays the base I/O port address and the Interrupt Request address of a serial port specified by the user.

Change Port 1 Settings/Change Port 2 Settings

This feature specifies the base I/O port address and the Interrupt Request address of Serial Port 1 or Serial Port 2. Select **Auto** for the BIOS to automatically assign the base I/O and IRQ address to a serial port specified.

The options for Serial Port 1 are **Auto**, (IO=3F8h; IRQ=4), (IO=3F8h; IRQ=3, 4, 5, 6, 7, 9, 10, 11, 12), (IO=2F8h; IRQ=3, 4, 5, 6, 7, 9, 10, 11, 12); (IO=3E8h; IRQ=3, 4, 5, 6, 7, 9, 10, 11, 12), and (IO=2E8h; IRQ=3, 4, 5, 6, 7, 9, 10, 11, 12).

The options for Serial Port 2 are **Auto**, (IO=2F8h; IRQ=3), (IO=3F8h; IRQ=3, 4, 5, 6, 7, 9, 10, 11, 12), (IO=2F8h; IRQ=3, 4, 5, 6, 7, 9, 10, 11, 12); (IO=3E8h; IRQ=3, 4, 5, 6, 7, 9, 10, 11, 12), and (IO=2E8h; IRQ=3, 4, 5, 6, 7, 9, 10, 11, 12).

Device Mode

Use this feature to configure SUART clock source settings. The options are **24MHz/13** and 24MHz.

Serial Port 2 Attribute

Select SOL to use COM Port 2 as a Serial_Over_LAN (SOL) port for console redirection. The options are **SOL** and COM.

►Serial Port Console Redirection

COM 1 Console Redirection (Available when COM1 port is detected)

Select Enabled to enable COM Port 1 Console Redirection, which will allow a client machine to be connected to a host machine at a remote site for networking. The options are **Disabled** and Enabled.

**If the item above is set to Enabled, the following items will become available for configuration:*

►COM1 Console Redirection Settings (Available when COM1 port is detected)

Terminal Type

This feature allows the user to select the target terminal emulation type for Console Redirection. Select VT100 to use the ASCII Character set. Select VT100+ to add color and function key support. Select ANSI to use the Extended ASCII Character Set. Select VT-UTF8 to use UTF8 encoding to map Unicode characters into one or more bytes. The options are VT100, **VT100+**, VT-UTF8, and ANSI.

Bits per second

Use this item to set the transmission speed for a serial port used in Console Redirection. Make sure that the same speed is used in the host computer and the client computer. A lower transmission speed may be required for long and busy lines. The options are 9600, 19200, 38400, 57600, and **115200** (bits per second).

Data Bits

Use this feature to set the data transmission size for Console Redirection. The options are 7 (Bits) and **8 (Bits)**.

Parity

A parity bit can be sent along with regular data bits to detect data transmission errors. Select Even if the parity bit is set to 0, and the number of 1's in data bits is even. Select Odd if the parity bit is set to 0, and the number of 1's in data bits is odd. Select None if you do not want to send a parity bit with your data bits in transmission. Select Mark to add a mark as a parity bit to be sent along with the data bits. Select Space to add a Space as a parity bit to be sent with your data bits. The options are **None**, Even, Odd, Mark, and Space.

Stop Bits

A stop bit indicates the end of a serial data packet. Select 1 Stop Bit for standard serial data communication. Select 2 Stop Bits if slower devices are used. The options are 1 and 2.

Flow Control

Use this item to set the flow control for Console Redirection to prevent data loss caused by buffer overflow. Send a "Stop" signal to stop sending data when the receiving buffer is full. Send a "Start" signal to start sending data when the receiving buffer is empty. The options are **None** and Hardware RTS/CTS.

VT-UTF8 Combo Key Support

Select Enabled to enable VT-UTF8 Combination Key support for ANSI/VT100 terminals. The options are Disabled and **Enabled**.

Recorder Mode

Select Enabled to capture the data displayed on a terminal and send it as text messages to a remote server. The options are **Disabled** and Enabled.

Resolution 100x31

Select Enabled for extended-terminal resolution support. The options are Disabled and **Enabled**.

Legacy OS Redirection Resolution

Use this item to select the number of rows and columns used in Console Redirection for legacy OS support. The options are 80x24 and **80x25**.

Putty KeyPad

This item selects Function Keys and KeyPad settings for Putty, which is a terminal emulator designed for the Windows OS. The options are **VT100**, LINUX, XTERMR6, SCO, ESCN, and VT400.

Redirection After BIOS Post

Use this item to enable or disable legacy Console Redirection after BIOS POST. When the option-Bootloader is selected, legacy Console Redirection is disabled before booting the OS. When Always Enable is selected, legacy Console Redirection remains enabled upon OS bootup. The options are **Always Enable** and Bootloader.

COM2/SOL

COM2/SOL Console Redirection

Select Enabled to use the SOL/COM2 port for Console Redirection. The options are Disabled and **Enabled**.

**If the item above is set to Enabled, the following items will become available for user's configuration:*

►COM2/SOL Console Redirection Settings

Use this feature to specify how the host computer will exchange data with the client computer, which is the remote computer used by the user.

Terminal Type

Use this feature to select the target terminal emulation type for Console Redirection. Select VT100 to use the ASCII Character set. Select VT100+ to add color and function key support. Select ANSI to use the Extended ASCII Character Set. Select VT-UTF8 to use UTF8 encoding to map Unicode characters into one or more bytes. The options are VT100, **VT100+**, VT-UTF8, and ANSI.

Bits per second

Use this feature to set the transmission speed for a serial port used in Console Redirection. Make sure that the same speed is used in the host computer and the client computer. A lower transmission speed may be required for long and busy lines. The options are 9600, 19200, 38400, 57600, and **115200** (bits per second).

Data Bits

Use this feature to set the data transmission size for Console Redirection. The options are 7 (Bits) and **8 (Bits)**.

Parity

A parity bit can be sent along with regular data bits to detect data transmission errors. Select Even if the parity bit is set to 0, and the number of 1's in data bits is even. Select Odd if the parity bit is set to 0, and the number of 1's in data bits is odd. Select None if you do not want to send a parity bit with your data bits in transmission. Select Mark to add a mark as a parity bit to be sent along with the data bits. Select Space to add a Space as a parity bit to be sent with your data bits. The options are **None**, Even, Odd, Mark, and Space.

Stop Bits

A stop bit indicates the end of a serial data packet. Select 1 Stop Bit for standard serial data communication. Select 2 Stop Bits if slower devices are used. The options are 1 and 2.

Flow Control

Use this feature to set the flow control for Console Redirection to prevent data loss caused by buffer overflow. Send a "Stop" signal to stop sending data when the receiving buffer is full. Send a "Start" signal to start data-sending when the receiving buffer is empty. The options are **None** and Hardware RTS/CTS.

VT-UTF8 Combo Key Support

Select Enabled to enable VT-UTF8 Combination Key support for ANSI/VT100 terminals. The options are Disabled and **Enabled**.

Recorder Mode

Select Enabled to capture the data displayed on a terminal and send it as text messages to a remote server. The options are **Disabled** and Enabled.

Resolution 100x31

Select Enabled for extended-terminal resolution support. The options are Disabled and **Enabled**.

Legacy OS Redirection Resolution

Use this feature to select the number of rows and columns used in Console Redirection for legacy OS support. The options are 80x24 and **80x25**.

Putty KeyPad

This feature selects Function Keys and Keypad settings for Putty, which is a terminal emulator designed for the Windows OS. The options are **VT100**, LINUX, XTERMR6, SCO, ESCN, and VT400.

Redirection After BIOS Post

Use this feature to enable or disable legacy Console Redirection after BIOS POST (Power-On Self-Test). When this feature is set to Bootloader, legacy Console Redirection is disabled before booting the OS. When this feature is set to Always Enable, legacy Console Redirection remains enabled upon OS boot. The options are **Always Enable** and Bootloader.

Legacy Console Redirection

► Legacy Console Redirection Settings

Legacy Serial Redirection Port

Use this feature to select the redirection of legacy OS or OPROM messages. The options are **COM1 Console Redirection** and COM2/SOL Console Redirection.

Serial Port for Out-of-Band Management/Windows Emergency Management Services (EMS)

The submenu allows the user to configure Console Redirection settings to support Out-of-Band Serial Port management.

EMS Console Redirection

Select Enabled to use a COM port selected by the user for EMS Console Redirection. The options are Enabled and **Disabled**.

**If the item above is set to Enabled, the following items will become available for user's configuration:*

► EMS Console Redirection Settings (Available when EMS Console Redirection is enabled)

Use this feature to specify how the host computer will exchange data with the client computer, which is the remote computer used by the user.

Out-of-Band Management Port

The feature selects a serial port in a client server to be used by the Windows Emergency Management Services (EMS) to communicate with a remote host server. The options are **COM1 Console Redirection** and SOL/COM2 Console Redirection.

Terminal Type

Use this feature to select the target terminal emulation type for Console Redirection. Select VT100 to use the ASCII character set. Select VT100+ to add color and function key support. Select ANSI to use the extended ASCII character set. Select VT-UTF8 to use UTF8 encoding to map Unicode characters into one or more bytes. The options are VT100, VT100+, **VT-UTF8**, and ANSI.

Bits Per Second

This item sets the transmission speed for a serial port used in Console Redirection. Make sure that the same speed is used in both host computer and the client computer. A lower transmission speed may be required for long and busy lines. The options are 9600, 19200, 57600, and **115200** (bits per second).

Flow Control

Use this item to set the flow control for Console Redirection to prevent data loss caused by buffer overflow. Send a "Stop" signal to stop data-sending when the receiving buffer is full. Send a "Start" signal to start data-sending when the receiving buffer is empty. The options are **None**, Hardware RTS/CTS, and Software Xon/Xoff.

The setting for each these features is displayed: Data Bits, Parity, and Stop Bits.

►ACPI Settings

WHEA Support

Select Enabled to support the Windows Hardware Error Architecture (WHEA) platform and provide a common infrastructure for the system to handle hardware errors within the Windows OS environment to reduce system crashes and to enhance system recovery and health monitoring. The options are Disabled and **Enabled**.

High Precision Timer

Select Enabled to activate the High Precision Event Timer (HPET) that produces periodic interrupts at a much higher frequency than a Real-time Clock (RTC) does in synchronizing multimedia streams, providing smooth playback and reducing the dependency on other timestamp calculation devices, such as an x86 RDTSC Instruction embedded in the CPU. The High Performance Event Timer is used to replace the 8254 Programmable Interval Timer. The options are Disabled and **Enabled**.

NUMA (Available when the OS supports this feature)

Select Enabled to enable Non-Uniform Memory Access support to enhance system performance. The options are Disabled and **Enabled**.

► Trusted Computing (Available when a TPM device is installed)

Configuration

Security Device Support

If this feature and the TPM jumper on the motherboard are both set to Enabled, onboard security devices will be enabled for TPM (Trusted Platform Module) support to enhance data integrity and network security. Please reboot the system for a change on this setting to take effect. The options are **Enabled** and Disabled.

TPM State

Select Enabled to use TPM (Trusted Platform Module) settings to enhance system data security. Please reboot your system for any change on the TPM state to take effect. The options are **Disabled** and Enabled.

Pending Operation

Use this item to schedule a TPM-related operation to be performed by a security device for system data integrity. Your system will reboot to carry out a pending TPM operation. The options are **0**, Enable Take Ownership, Disable Take Ownership, and TPM Clear.

Note: Your system will reboot to carry out a pending TPM operation.

Current Status Information

This item displays the status of the TPM support on this motherboard.

TXT Support

Select Enabled to use Intel Trusted Execution Technology to enhance system security and data integrity. The options are **Enabled** and Disabled.

► iSCSI Configuration

This item displays iSCSI configuration information:

iSCSI Initiator Name

This item displays the name of the iSCSI Initiator, which is a unique name used in the world. The name must use the IQN format. The following actions can also be performed:

7-4 Event Logs

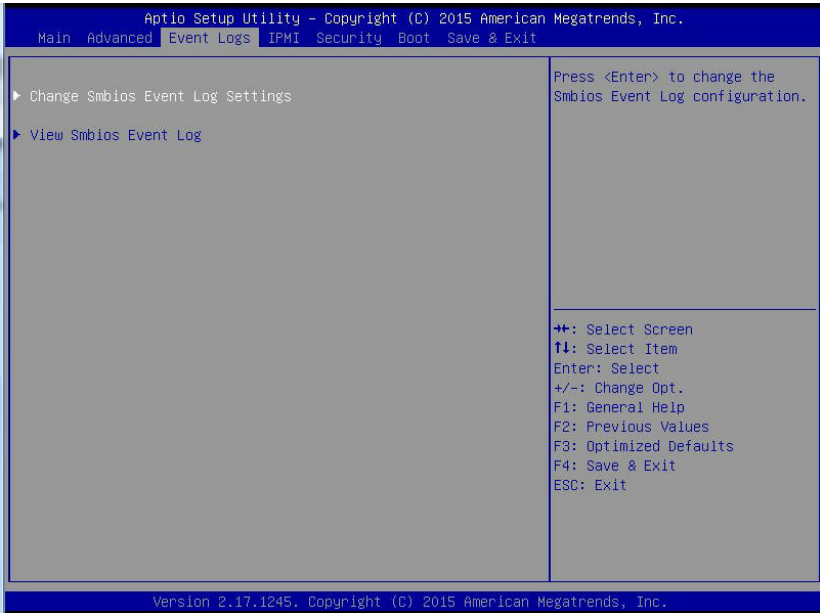

Select the Event Logs tab to access the following submenu items.

► Change Smbios Event Log Settings

Enabling/Disabling Options

SMBIOS Event Log

Select Enabled to enable SMBIOS (System Management BIOS) Event Logging during system boot. The options are Disabled and **Enabled**.

Runtime Error Logging Support

Select Enabled to support Runtime Error Logging. The options are Disabled and **Enabled**.

Erasing Settings

Erase Event Log

Select Enabled to erase all error events in the SMBIOS (System Management BIOS) log before an event logging is initialized at bootup. The options are **No**; Yes, Next reset; and Yes, Every reset.

When Log is Full

Select Erase Immediately to immediately erase all errors in the SMBIOS event log when the event log is full. Select Do Nothing for the system to do nothing when the SMBIOS event log is full. The options are **Do Nothing** and Erase Immediately.

SMBIOS Event Log Standard Settings**Log System Boot Event**

Select Enabled to log system boot events. The options are Enabled and **Disabled**.

MECI (Multiple Event Count Increment)

Enter the increment value for the multiple event counter. Enter a number between 1 to 255. The default setting is **1**.

METW (Multiple Event Count Time Window)

This item is used to determine how long (in minutes) the multiple event counter should wait before generating a new event log. Enter a number between 0 to 99. The default setting is **60**.

Note: Please reboot the system for the changes to take effect.

►View SMBIOS Event Log

This item allows the user to view the event in the SMBIOS event log. Select this item and press <Enter> to view the status of an event in the log. The following categories are displayed:

Date/Time/Error Code/Severity

7-5 IPMI

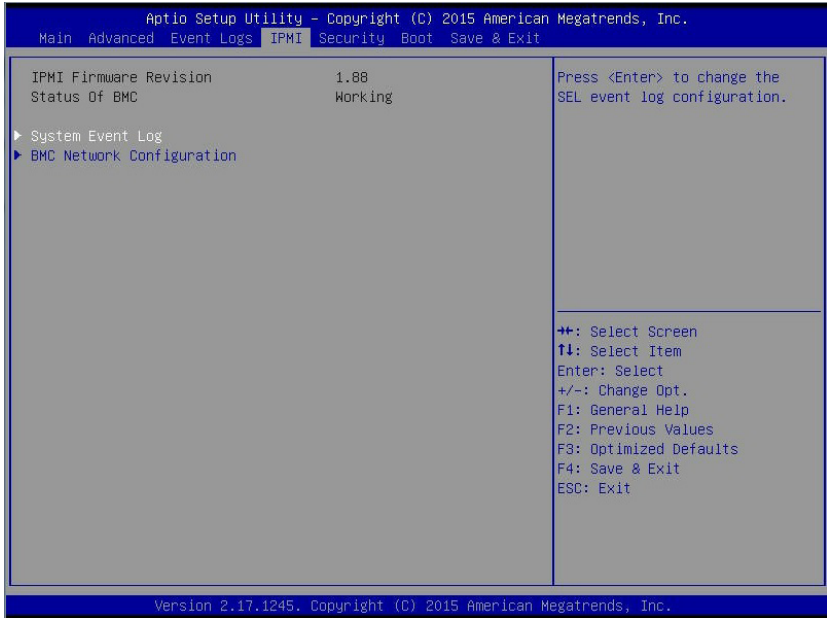

Use this feature to configure Intelligent Platform Management Interface (IPMI) settings.

IPMI Firmware Revision

This item indicates the IPMI firmware revision used in your system.

Status of BMC (Baseboard Management Controller)

This item indicates the status of the BMC installed in your system.

► System Event Log

Enabling/Disabling Options

SEL Components

Select Enabled to enable all system event logging support at bootup. The options are Disabled and **Enabled**.

Erasing Settings

Erase SEL

Select Yes, On next reset to erase all system event logs upon next system reboot. Select Yes, On every reset to erase all system event logs upon each system reboot. Select No to keep all system event logs after each system reboot. The options are **No**; Yes, On next reset; and Yes, On every reset.

When SEL is Full

This feature allows the user to determine what the AMI BIOS should do when the system event log is full. Select Erase Immediately to erase all events in the log when the system event log is full. The options are **Do Nothing** and Erase Immediately.

Custom EFI Logging Options

Log EFI Status Codes

Select Error Code to log EFI error codes. Select Progress Code to log EFI progress codes. Select Both to log both error codes and progress codes. The options are Disabled, Both, **Error Code**, and Progress Code.

Note: After making changes on a setting, be sure to reboot the system for the changes to take effect.

► BMC Network Configuration

The following items will be displayed:

Update IPMI LAN Configuration

Select Yes for the system BIOS to automatically reset the following IPMI settings at the next system boot. The options are **No** and Yes.

Configuration Address Source (Available when the item above, Update IPMI LAN Configuration, is set to Yes)

Use this item to select the IP address source for this computer. If Static is selected, you will need to know the IP address of this computer and enter it to the system manually in the field. If DHCP is selected, AMI BIOS will search for a DHCP (Dynamic Host Configuration Protocol) server attached to the network and request the next available IP address for this computer. The options are Static and **DHCP**.

Station IP Address

This item displays the Station IP address for this computer. This should be in decimal and in dotted quad form (i.e., 192.168.10.253).

Subnet Mask

This item displays the sub-network that this computer belongs to. The value of each three-digit number is separated by dots and it should not exceed 255.

Station MAC Address

This item displays the Station MAC address for this computer. Mac addresses are 6 two-digit hexadecimal numbers.

Router IP Address

This item displays the router IP address for this computer. This should be in decimal and in dotted quad form (e.g., 192.168.10.253).

7-6 Security

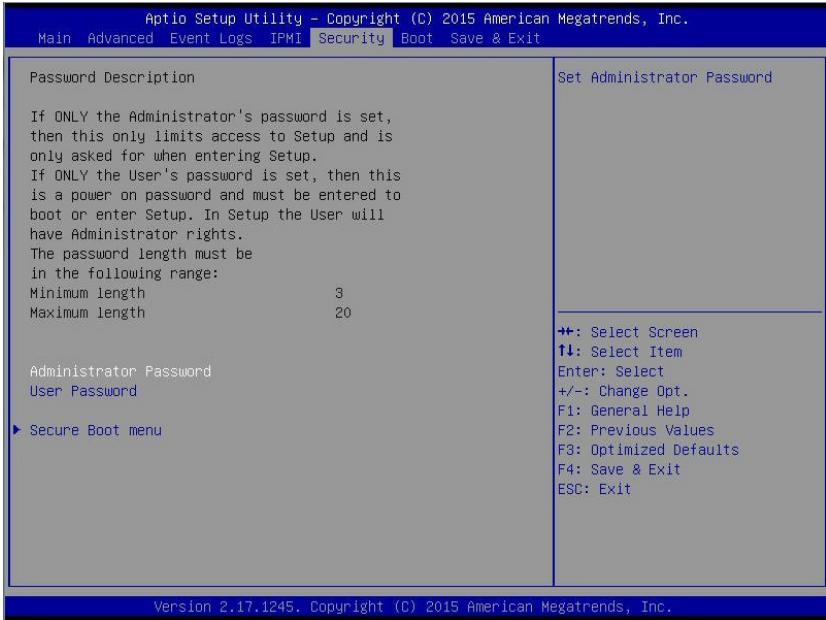

This menu allows the user to configure the following security settings for the system.

Administrator Password

Use this feature to set the administrator password which is required before the user entering the BIOS setup utility. The length of the password should be from 3 characters to 20 characters long.

User Password

Use this feature to set the user password which is required to enter the BIOS setup utility. The length of the password should be from 3 characters to 20 characters long.

► Secure Boot Menu

The following items will display:

- System Mode
- Secure Boot

Secure Boot

Select Enable for secure boot support to ensure system security at bootup. The options are **Disabled** and Enabled.

Secure Boot Mode

This item allows the user to select the desired secure boot mode for the system. The options are Standard and **Custom**.

►Key Management

Default Keys Provision

Select Enable to install all manufacturer defaults for the following system security settings. The options are **Disabled** and Enabled.

►Enroll All Factory Default Keys

Select Enable to install all manufacturer defaults for the following system security settings. The options are **Yes** and No.

►Save All Secure Boot Variables

This feature allows the user to save the secure boot settings specified by the user.

Platform Key (PK)

►Delete PK

Select <Yes> to confirm deletion of the Platform Key (PK) from the NVRAM (Non-Volatile RAM).

►Set New PK

Select <Yes> to load the manufacture_default platform keys for your system. Select No to load the default settings from other sources.

Key Exchange Key (KEK)

Select <Yes> to confirm KEK support to enhance system security.

►Delete KEK (Key Exchange Key)

Select <Yes> to confirm deletion of the KEK from the NVRAM (Non-Volatile RAM).

►Set New KEK (Key Exchange Key)

Select <Yes> to confirm that a new KEK will be set in the NVRAM (Non-Volatile RAM).

►Append KEK (Key Exchange Key)

Select <Yes> to load the new KEK from the manufacturer defaults. Select <No> to load the new KEK from other sources.

Authorized Signatures**►Delete DB (DataBase)**

Select <Yes> to confirm deletion of a database from the NVRAM (Non-Volatile RAM).

►Set New DB (DataBase)

Select <Yes> to confirm that a new database will be set in the NVRAM (Non-Volatile RAM).

►Append DB (DataBase)

Select <Yes> to load the new database from the manufacturer defaults. Select <No> to load the new database from other sources

Authorized TimeStamps**►Delete DBT (DataBase Timer)**

Select <Yes> to confirm deletion of the database timer from the NVRAM (Non-Volatile RAM).

►Set New DBT (DataBase Timer)

Select <Yes> to confirm that the new database timer will be set in the NVRAM (Non-Volatile RAM).

►Append DBT (DataBase Timer)

Select <Yes> to load the new database timer from the manufacturer defaults. Select <No> to load the new database timer from other sources

Forbidden Signatures

►Delete DBX

Select <Yes> to confirm deletion of the DBX files from the Non-Volatile RAM (NVRAM).

►Set New DBX

Select <Yes> to confirm that the new DBX files will be downloaded to the Non-Volatile RAM (NVRAM).

►Append DBX (DataBase Timer)

Select <Yes> to load the new DBX files from the manufacturer defaults. Select <No> to load the new DBX files from other sources.

7-7 Boot

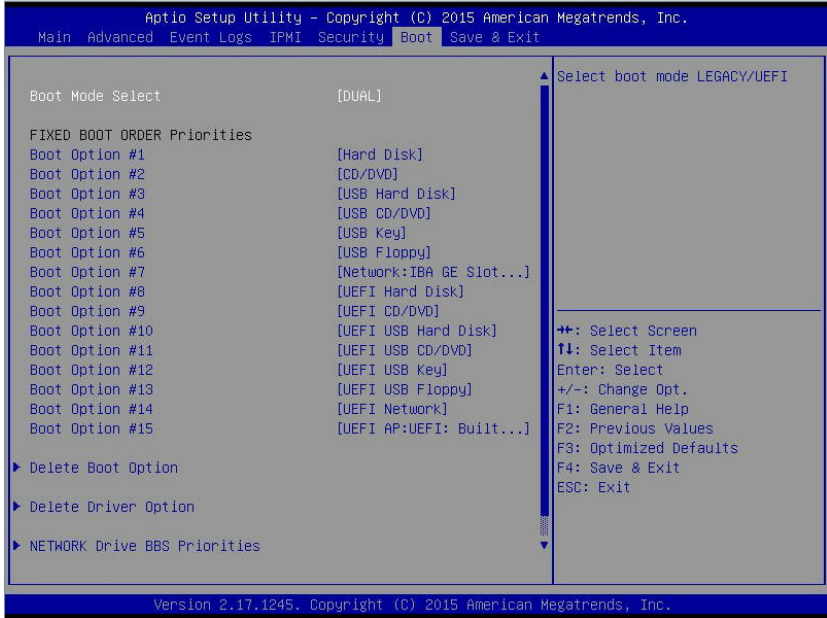

This submenu allows the user to configure the following boot settings for the system.

Boot Configuration

Boot Mode Select

Use this item to select the type of device to be used for system boot. The options are Legacy, UEFI, and **Dual**.

Fixed Boot Order Priorities

This option prioritizes the order of bootable devices from which the system will boot. Press <Enter> on each entry from top to bottom to select devices.

- Boot Option #1
- Boot Option #2
- Boot Option #3
- Boot Option #4
- Boot Option #5
- Boot Option #6

- Boot Option #7
- Boot Option #8
- Boot Option #9
- Boot Option #10
- Boot Option #11
- Boot Option #12
- Boot Option #13
- Boot Option #14
- Boot Option #15

► **Delete Boot Option**

Use this item to select a boot device to delete from the boot priority list.

Delete Boot Option

Select the target boot device to delete.

► **Delete Driver Option**

Use this item to select a boot driver to delete from the boot priority list.

Delete Driver Option

Select the target boot driver to delete.

► **Hard Disk Drive BBS Priorities**

- Boot Option #1
- Boot Option #2

► **Network Drive BBS Priorities**

- Boot Option #1

► **UEFI Application Boot Priorities**

- Boot Option #1

7-8 Save & Exit

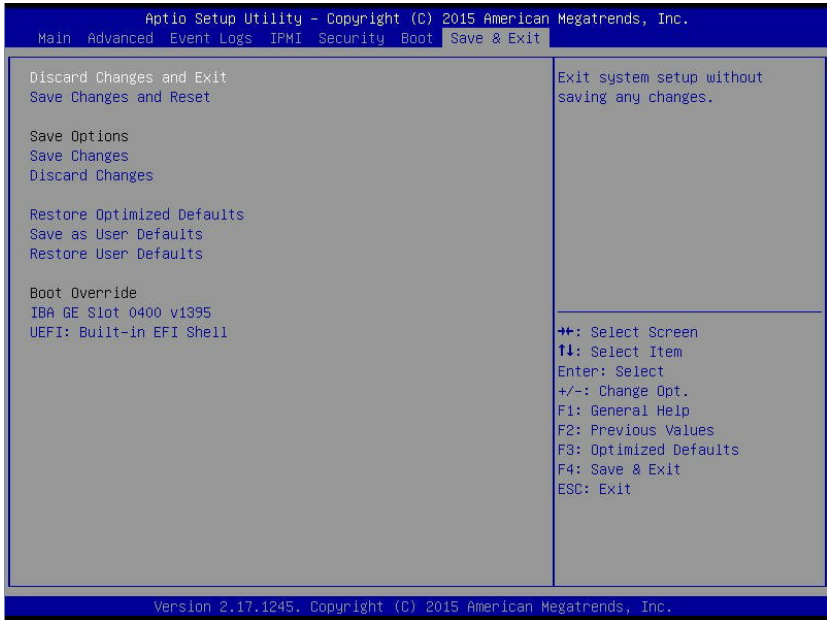

Use this page to configure the Save & Exit settings for setup.

Discard Changes and Exit

Select this option and press <Enter> to quit the BIOS setup without making any permanent changes to the system configuration, and reboot the computer.

Save Changes and Reset

When you have completed the system configuration changes, select this option and press <Enter> to leave the BIOS setup utility and reboot the computer for the new system configuration parameters to take effect.

Save Options

Save Changes

When you have completed the system configuration changes, select this option and press <Enter> to save all changes made. This will not reset (reboot) the system.

Discard Changes

Select this option and press <Enter> to discard all the changes and return to the AMI BIOS setup utility.

Restore Optimized Defaults

To set this feature, select this option and press <Enter> to reload the manufacturer default settings that are designed for maximum system performance but not for maximum stability.

Save as User Defaults

To set this feature, select this option and press <Enter> to save current default settings for future use.

Restore User Defaults

To set this feature, select this option and press <Enter> to retrieve user-defined settings that were previously saved.

Boot Override

This feature allows the user to override the Boot priorities sequence in the Boot menu, and immediately boot the system with a new device specified by the user. This is a one-time override.

Appendix A

BIOS Error Beep Codes

During the POST (Power-On Self-Test) routines, which are performed at each system boot, errors may occur.

Non-fatal errors are those which, in most cases, allow the system to continue to boot. The error messages normally appear on the screen.

Fatal errors will not allow the system to continue with bootup procedure. If a fatal error occurs, you should consult with your system manufacturer for possible repairs.

These fatal errors are usually communicated through a series of audible beeps. The numbers on the fatal error list correspond to the number of beeps for the corresponding error.

BIOS Error Beep Codes		
Beep Code/LED	Error Message	Description
1 beep	Refresh	Ready to boot
5 short beeps + 1 long beep	Memory error	No memory detected in the system
5 beeps	No Con-In or No Con-Out devices	Con-In: USB or PS/2 keyboard, PCI or Serial Console Redirection, IPMI KVM or SOL Con-Out: Video Controller, PCI or Serial Console Redirection, IPMI SOL
X10 IPMI Error Codes		
1 Continuous Beep	System OH	System Overheat

Notes

Appendix B

System Specifications

Processors

Two Intel E5-2600 v3 Series series processors in Socket R LGA 2011 type sockets

Note: please refer to our website for details on supported processors.

Chipset

Intel PCH C612 chipset

BIOS

128 MB SPI Flash EEPROM with AMI BIOS

Memory Capacity

Sixteen DIMM slots supporting up to 1 TB of LRDIMM. 512 GB of RDIMM ECC DDR4-2133/1866/1600MHz memory.

Note: Refer to Section 5-5 for details on installation. Check the Supermicro website (www.supermicro.com) for the latest memory support information.

Drive Bays

Two hot-swap drive bays to house 2.5" SATA drives

Two fixed internal 2.5" drives

GPUs (Graphics Processing Units)

Four GPUs PCI-E 3.0 x16 slots (4x GPU/Xeon Phi cards optional); supports GPUs K1/K2/K40M/K80/Xeon Phi.

PCI Expansion

Two PCI-E 3.0 x8 (in x16) low-profile slots

Serverboard

X10DGQ (proprietary form factor)

Dimensions: 17 x 19 in. (43.2 x 48.3 mm)

Chassis

SC118GQE-R2K03 (1U rackmount)

Dimensions: (WxHxD) 17.2 x 1.7 x 35.2 in. (437 x 43 x 894 mm)

Weight

Net Weight: 45 lbs (15.9 kg)

Gross Weight: 58 lbs (21.8 kg)

System Cooling

Nine 4-cm fans, one air shroud, two passive CPU heat sinks

System Input Requirements

AC Input Voltage: 100-240VAC auto-range

Rated Input Current: 1000W: 100-120V/12.5A, 2000W: 200-240V/10A

Rated Input Frequency: 50 to 60 Hz

Power Supply

Rated Output Power: 1000W/2000W (Part# PWS-2K03P-1R)

Rated Output Voltages: 1000W: +12V (83A), +12Vsb (3.5A), 2000W: +12V (167A), +12Vsb (3.5A)

Operating Environment

Operating Temperature: 10° to 35° C (50° to 95° F)

Non-operating Temperature: -40° to 70° C (-40° to 158° F)

Operating Relative Humidity: 8% to 90% (non-condensing)

Non-operating Relative Humidity: 5 to 95% (non-condensing)

Regulatory Compliance

Electromagnetic Emissions: FCC Class A, EN 55022 Class A, EN 61000-3-2/-3-3, CISPR 22 Class A

Electromagnetic Immunity: EN 55024/CISPR 24, (EN 61000-4-2, EN 61000-4-3, EN 61000-4-4, EN 61000-4-5, EN 61000-4-6, EN 61000-4-8, EN 61000-4-11)

Safety: CSA/EN/IEC/UL 60950-1 Compliant, UL or CSA Listed (USA and Canada), CE Marking (Europe)

California Best Management Practices Regulations for Perchlorate Materials:
This Perchlorate warning applies only to products containing CR (Manganese
Dioxide) Lithium coin cells. "Perchlorate Material-special handling may apply.
See www.dtsc.ca.gov/hazardouswaste/perchlorate" for further details.

(continued from front)

The products sold by Supermicro are not intended for and will not be used in life support systems, medical equipment, nuclear facilities or systems, aircraft, aircraft devices, aircraft/emergency communication devices or other critical systems whose failure to perform be reasonably expected to result in significant injury or loss of life or catastrophic property damage. Accordingly, Supermicro disclaims any and all liability, and should buyer use or sell such products for use in such ultra-hazardous applications, it does so entirely at its own risk. Furthermore, buyer agrees to fully indemnify, defend and hold Supermicro harmless for and against any and all claims, demands, actions, litigation, and proceedings of any kind arising out of or related to such ultra-hazardous use or sale.