



User Manual

DPP-350 Mobile Printer

2-inch Mobile Printer





Contact Information

Mobility Sales/ Technical Support Center

Infinite Peripherals, Inc.
17681 Mitchell N
Irvine, CA 92614

Toll-Free: (877) 278-7860

Office: (949) 222-0300

Website: ipcmobile.com

Headquarters/ Main Warehouse

Infinite Peripherals, Inc.
2312 Touhy Avenue
Elk Grove Village, IL 60007

Toll-Free: (800) 278-7860

Office: (847) 818-1260

Fax: (847) 818-1287

Legal Notice

“Made for iPhone” (MFi) means that an electronic accessory has been designed to connect specifically to the iPhone and has been certified by the developer to meet Apple performance standards. Apple is not responsible for the operation of this device or its compliance with safety and regulatory standards. Please note that the use of this accessory with an iPhone may affect wireless performance.

Trademarks

Infinite Peripherals, Mobilize Your Enterprise, Linea Pro, Infinea Tab, and Infinea Omni are trademarks of Infinite Peripherals, Inc. All other trademarks are the property of their respective owners.



Table of Contents

Contact Information	2	DIP Switch Location	13
Legal Notice	2	DIP Switch Settings	13
Trademarks	2	Memory Switch Settings	14
Overview	4	Set-up the Hardware Memory Switch	14
Guidelines for Use	4	Memory Switch Configuration	14
Environmental	4	Communication Configuration	14
Mechanical	4	Bluetooth Pairing	15
Technical Specifications	6	Pair Your iOS Device	15
Box Contents	7	Pair Your Android Device	15
Getting Started	8	(Optional) Magnetic Stripe Reader	16
Developing Applications	8	Battery Disposal	16
Accessories	8	Replacing the Battery	16
Product Overview	9	Resident Command Set	17/18
Charge Your DPP-350	10	Troubleshooting	19
LED Status	10	Servicing Your Printer	19
Replace the Battery	11	Product Returns & Servicing	19
Status and Operational Modes	11	Disclaimer	20
Using Your DPP-350	12	Warranty	20
Installing a Paper Roll	12	Symbols	20
Diagnostic Self-Test	12	Federal Communications Commission	21



Overview

With the DPP-350 mobile printer you can print data from your smart phone via Bluetooth. Before using the printer, ensure the battery is fully charged.

Guidelines for Use

Environmental

To prevent printer failure and/or serious personal injury, avoid using the mobile printer under these conditions:

- Anywhere the printer may be exposed to dust, moisture, or direct sunlight/heat.
- Slanted surfaces or surfaces subject to shocks or vibrations.
- Temperatures exceeding 60 degrees C or less than -20 degrees C, or with relative humidity of 85% or more.
- Areas subject to electromagnetic noise or corrosive gas.
- If condensation exists on the mobile head, turn the power off until the condensation evaporates completely.

Mechanical

To prevent the heating elements and driver's integrated circuit (IC) from exposure to static electricity, use caution when handling the mobile head.

To prevent damage and/or contamination, avoid the following:

- Touching the dot line on the mobile head/driver IC with metal, sandpaper, or your fingers.
- Volatile chemicals, such as thinners or benzene for maintenance work.
- Opening the paper during printing.
- Pulling the paper out of the printer forcibly when the printer cover is closed.
- Loose paper or paper blocking exit tray may cause the paper to jam.

Note

If the paper jams in the paper exit tray, turn off the power to the printer.

- Do not attempt to disassemble or repair the printer, AC adapter, or power cord yourself. Contact Infinite Peripherals at <https://ipcmobile.com/support/support-form>



Electrical

Turn off the printer and disconnect the AC adapter from the power outlet when/IF these happen:

- Smoke, odd smells, or unusual noises are emitted by the printer.
- Metallic objects are dropped, or any liquid is spilled inside the printer.
- Printer is not in use.

Important: Do Not

- Connect or disconnect the AC adapter with wet hands as this can result in electric shock, short circuit, and failure.
- Use any AC adapter or power cord or place heavy objects on top of the printer as this may cause damage to the cord and/or create a fire or electric shock.
- Bend the power cord or place heavy objects on top of it as this can cause damage the cord and/or cause fire or electric shock.
- Drop any metallic objects or spill liquids such as coffee, water into the printer.
- Do not touch the head as it is hot after printing. Ensure the thermal head is cool before replacing the paper or cleaning the printer head.
- Remove the cable or adapter from the connector or the receptacle by gripping the connector or the plug. In addition, never pull the cable itself since this may cause damage to the cable and/or adapter.

Operational

Use only specified paper or equivalent in your printer. Other paper can reduce the life of the printer head and decrease the printing quality. Store the paper in a cool, dry, and dark location.

Note

Any substances with Sodium (Na+), Potassium (K=), or chlorine (Cl-) can reduce the life of the printer head remarkably.

Ensure the paper is stored in a cool, dry, dark place. We recommend you do not expose the paper to bright light for extended periods of time, organic solvents, or vinyl chloride film, erasers, or adhesive tapes. In addition, do not store the paper in high temperature or humidity environments, damp areas or areas with exposure to direct sunlight. If pasting printed pages, only use water-based glue, that is starch glue, synthetic glue, and so forth.

Important: Do Not

- Store the paper on diazo print paper or on wet, freshly made paper copies.
- Handle the paper with wet hands or hard objects since it can cause tears, fingerprints, or smudges.
- Expose the paper
 - * To bright light or extended periods of time.
 - * To organic solvents.
 - * To vinyl chloride film erasers, or adhesive tapes.
- Store the paper
 - * In high temperatures, high humidity, damp areas.

Note

If the printer is used continuously under improper conditions can lead to failure, fire, and/or electric shock. This may void your warranty. If a fault condition continues, contact <https://ipcmobile.com/support>



Technical Specifications

Printing	
Printing Method	Line thermal dot printing
Printing Speed	60mms/s (480 dots per second) at 8.5V
Print Width	72mm/576 dots per line
Resolution	203dpi (8 x 9 dot/mm)
Dot Pitch	Horizontal and vertical: 0.125mm (8 dots/mm)
Resident Fonts	A: 12 x 24 dots (48 char per line) B: 9 x 16 dots (64 char per line)
Loadable Fonts	C: 12 x 24 (48 char per line) D: 9 x 16 dots (64 char per line)
Logo Registration	One black and white with 576 x 248 dots
Input Buffer	36,864 bytes
Resident Barcodes	1D: EAN13, EAN8, UPC-A, UPC-E, Codebar, Code39, Code128 2D: PDF417, QR Code
Emulation	ESC/POS Continuous Paper Mode
Thermal Paper	78mm +0/-1mm x 50mm diameter 57mm x 50mm diameter (Optional)
Reliability	Printing head: 50km Printing rate: 25% maximum
Physical	
Compatibility	Apple iOS devices, Window O/S, Android O/S
Dimensions W x D x H	118mm x 90mm x 51mm (4.6" x 3.5" x 2")
Weight	340 grams (oz) - Without paper 430 grams (oz) - With paper
Electrical	
Battery Capacity	User-replaceable, rechargeable Li-ion battery 7.4V / 110mAH
Battery Life	~30,000 lines per charge
Power Supply	AC adapter: DC 9V, 1A AC 100-240V 13.A, 50/60 Hz
Magnetic Stripe Reader	(Optional) 3-track unencrypted read head, ISO7811
Connectivity	(Optional) Bluetooth 2.0 class 2 SPP (Optional) Bluetooth 3.0 class 2 SPP, iPod accessory protocol mini USB port RS232 C 115200bps maximum serial port
Environmental	
Operating Temperature	+0°C to +45°C (32°F to +113°F)
Relative Humidity	35% to 85%
Storage Temperature	-20°C to +60°C (-4°F to +140°F)
Relative Humidity	10% to 90%



Box Contents

- Before using your DPP-350 printer, remove the printer and all included accessories from the shipping carton and verify the contents against the packing list.
- Retain all packing materials, invoice, and bill of lading. This may be required to return the unit for servicing later, or to process a claim with the shipping carrier.
- Inspect carefully the contents inside the box carefully for any signs of damage. Do not use if any sign of damage. Notify your Infinite Peripherals account executive or contact technical support at <https://ipcmobile.com/support/technical-services>
- Ensure the battery pack is fully charged before first use.

DPP-350 Printer / Belt Clip (1) / Battery Inside



RS-232 Interface Cable (1)



AC Charger (1)



Roll of Thermal Paper(1)



Note

Box contents and SKUs vary based on your order configuration.



Getting Started

Refer to these sections to help you get the DPP-350 printer ready for use:

What to do	Section
Charge the DPP-350 Lithium-ion battery pack fully before first use.	Charging Your DPP-350
Load DPP-350 print media, that is thermal paper.	Using Your DPP-350
Install software from the SDK onto your mobile device to use the features of the printer.	Developing Applications
Set-up Bluetooth pairing to communicate with the printer.	Bluetooth Pairing

Accessories

Visit our website at <https://ipcmobile.com> or contact your Infinite Peripherals account representative for additional information about our current and future product accessories.

Developing Applications

Software is not provided with your mobile printer. Please contact your reseller or Infinite Peripherals for Third Party software solutions.

Integrating the printer with your mobile application requires the use of the Infinite Peripherals Software Developers Kit (SDK). The SDK incorporates an API specifically for developing applications to use the magnetic strip functionalities of the mobile printer.

To download the InfineaSDK or IPCMPPrinterSDK, access our Development Portal at <https://developer.ipcmobile.com/>



Product Overview

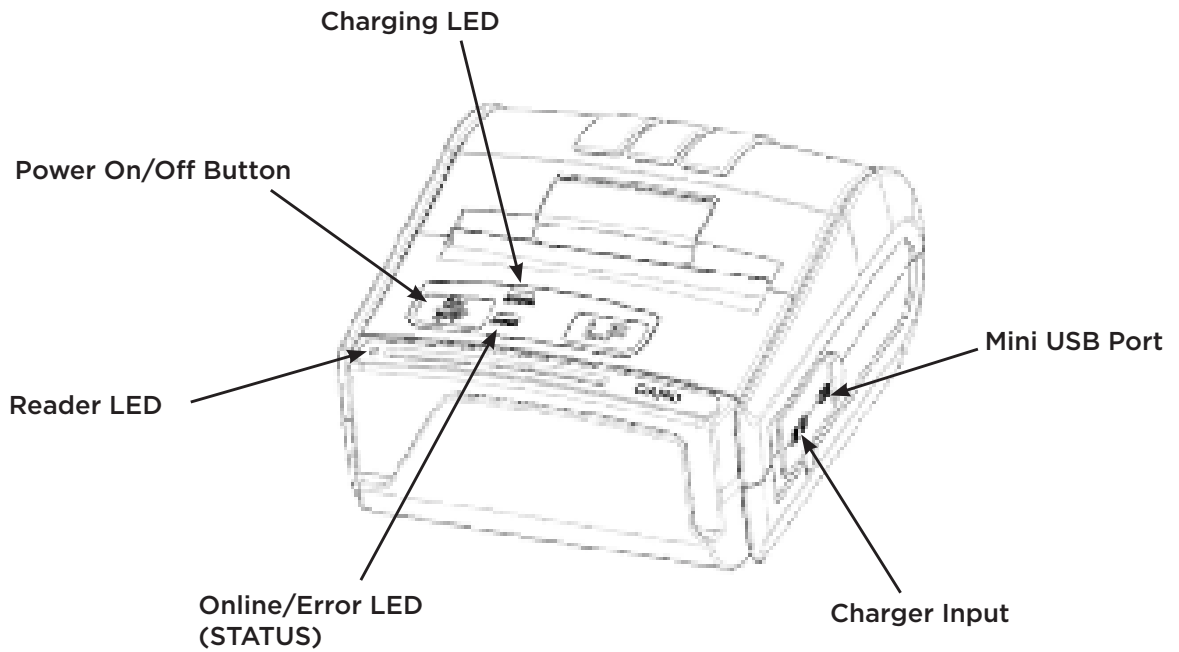
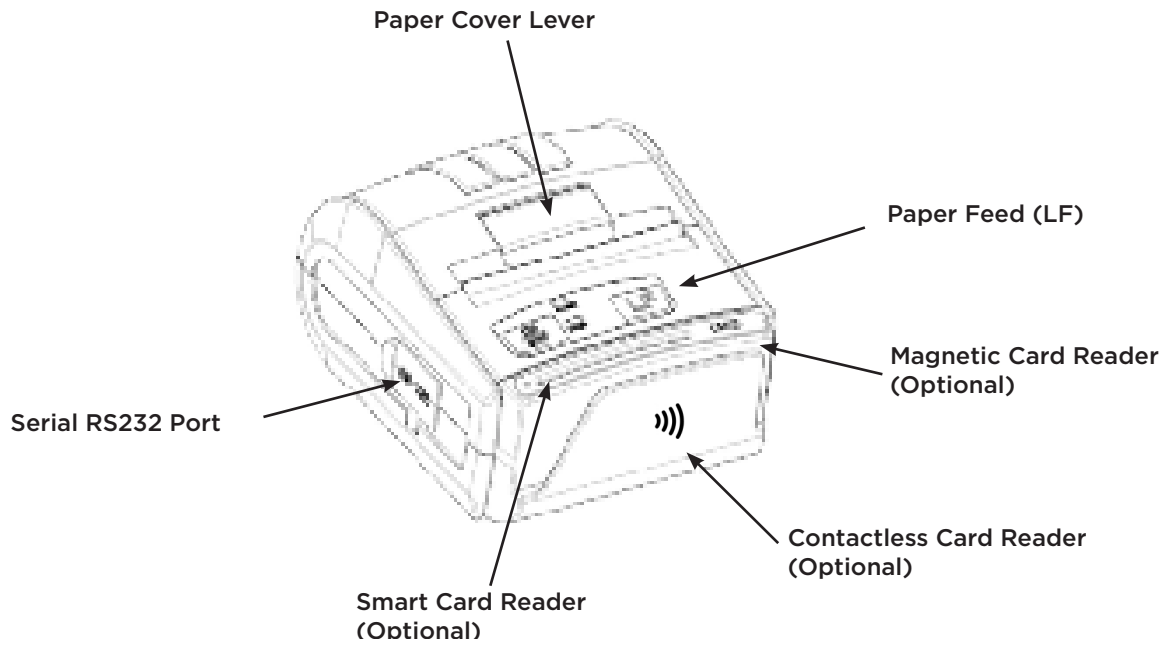



Charge Your DPP-350

Before operating the DPP-350 printer, install the Lithium Ion rechargeable battery. Ensure the battery pack is charged for at least 4 hours.

Note



Ensure the input cord is connected to the AC adapter before charging the battery.

To prevent electrical damage to your printer and/or battery pack, only use the approved AC charger provided with the printer.

1. Pull the DC jack port tab backwards.
2. Insert the AC adapter into the port.
3. Introduce the AC adapter plug into an appropriate power outlet to begin charging.

Note

LED status during charging is displayed.

-  Solid Red = Charging
-  Solid Green = Fully Charged

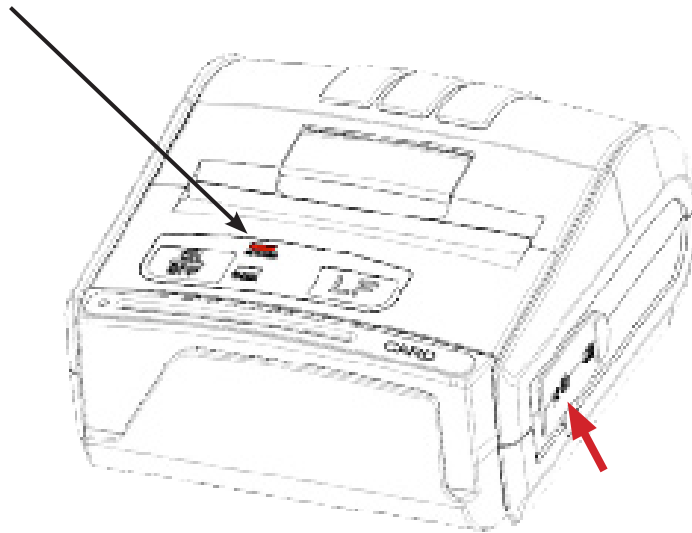

LED Status

After the initial battery charge is completed, you can monitor the battery status, as needed. If the operating time of a fully charged battery is too short, you may need to replace the battery.



Replace the Battery

1. Open the battery compartment cover on the bottom of the printer by rotating the two locking levers.

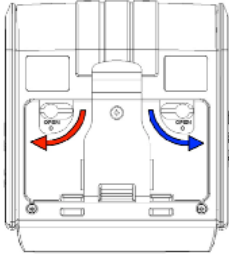

2. Remove the battery cover.

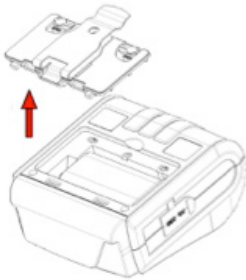

3. Lift the battery upwards from the compartment carefully.

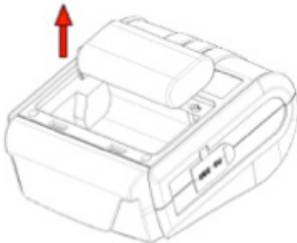

4. Pull the battery connector wires to detach the battery connector gently.



5. Replace the cover.

Status and Operational Modes

The LEDs on the printer indicate the modes of operations. LEDs illuminate information about the connection status, charging and/or low battery status.

The statuses and descriptions are

LED Color	Description
Red Solid	Battery charging, or Paper is out or at the end
Green Solid	Battery charging complete Power is on
Green Flashes 1 per sec	Low battery
Red flash Green flash	Printer head is overheating

Note

Dispose of used batteries in accordance with Federal law. This may include disposing them at a recycling center or hazardous waste collection site.



Using Your DPP-350

Installing a Paper Roll

Before replacing the paper roll or closing the cover, ensure the mobile head is cool. The mobile head may be very hot immediately after printing.

Note

Touching the mobile head while hot may result in burn injuries.

1. To open the printer cover, lift the paper cover up.



2. Place a new paper roll into place.

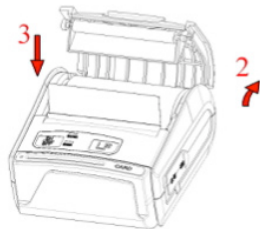

Note

Ensure at least 12mm or more of the media is above the top of the printer before closing the printer cover.

3. Use both hands to close the paper cover to ensure it is closed completely.



4. Close the paper cover until you hear the lock into place.

Diagnostic Self-Test

The built-in test pattern shows the DPP-350 printer's current configuration and resident fonts. The self test is used for troubleshooting and helps you determine printing issues or battery statuses.

LP button operation modes are completed when the print is turned on:

Action	Result
1. Hold LP for ~0.5 second.	Short self text prints automatically
2. Release after one beep.	
3. Hold LP for ~2.5 seconds.	Hex dump mode All input data is printed as hexadecimal
4. Release after two beeps.	
5. Hold LP for 8.5 seconds.	Program mode Loads printer firmware
6. Release after the fifth beep (long 4-tone).	
7. Hold LP for ~4 seconds.	Forces 9600 bps serial speed temporarily
8. Release after one beep.	
9. Hold ON button for ~6 seconds.	Hardware set-up mode

Long Self Test

When the printer is turned on, press and hold the LP button. Release after 4.5 seconds when you hear three beeps. A long self test prints with information about these criteria:

- Resident font sizes
- Characters per line
- Text formatting
- Resident character set
- Resident barcode symbols
- Printer configuration



DIP Switch Location

1. To locate the DIP switch settings, turn the printer to the back side, and rotate the two locking levers (see 1a & 1b).
2. To remove the battery cover, lift it upwards.
3. Remove the battery.
4. Turn the desired switch On or Off, as needed.

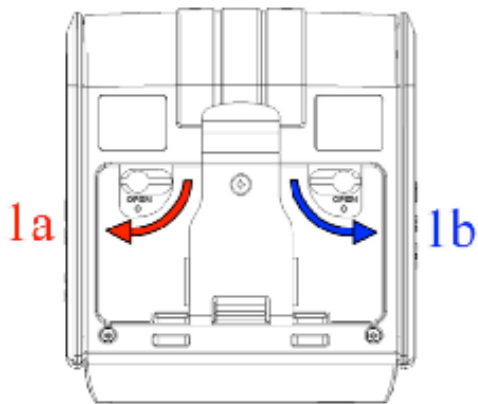

DIP Switch Settings

With the different methods of communication designed in the DPP-350, ensure the DIP switches remain as the factory default, unless required for change. Two different operational modes, which detect current conditions differently, and are determined by the SW2 switch:

- Continuous Paper Mode.
- Black Mark Mode – Determines the proper alignment for the starting print position on indexed media with printed data.

Switch	Off	On
SW1	Enable Bluetooth	Disable Bluetooth
SW2	Continuous Paper Mode	Black Mark Mode
SW3	None	Xon / Xoff protocol
SW4	Normal operation mode	Protocol mode



Memory Switch Settings

Non-volatile memory is used in storing the printer's default configuration settings.

Note

If you change any factory preset configurations, verify the settings are correct.

The available options are:

Memory Switch Options	
Memory switch (GS command)	1000000010
Baud Rate	115200 bps
Auto Off Time	10 minutes
Print Darkness	100%
Character Table	Western (1252)
USB Device Class	Printer

Set-up the Hardware Memory Switch

1. Turn the printer Off (ERR LED is off) before proceeding.
2. Press and hold down the Power button. ERR LED flashes red and green every second.
3. Release the On button after approximately 6 seconds.
4. Wait for the Out of Current Memory settings page to print, and then follow the instructions from the printer and make any necessary changes.

- * Press LF (Yes) to accept changes.
- * Press On/Off (No) to cancel changes.

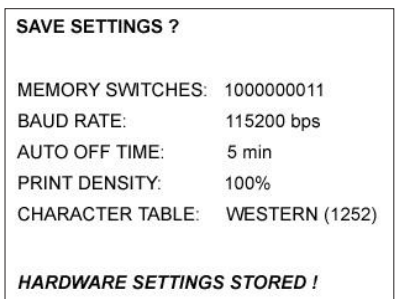
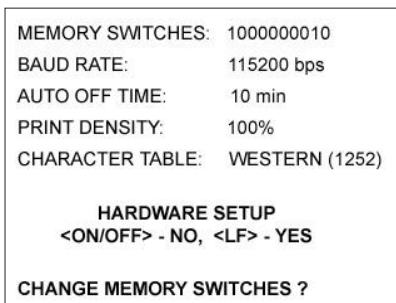

Memory Switch Configuration

Ten memory switches are available on the DPP-350.

Memory Switch	Description
SW1	Enable/disable buzzer
SW2	Disable CR CR executed as LF
SW3	Enable/disable LF
SW4	LF after CR Disable LF after CR
SW5	Font A (12x24) Font B (9x16)
SW6-7	Reserved for future use
SW8	Enable - Prevents others from discovering printer Must be set after pairing finished
SW9	Enable/disable USB USB port for communication is allowed
SW10	(Off) Set USB for Host/Device mode

Communication Configuration

The configuration methods for communication using the DPP-350 are via your smart phone or Bluetooth.

Note

If not using a driver or the SDK developer tools, set DIP switch 4 to OFF.

* Indicates 1 or 0 may be used based on user requirements.

- Memory switch options 1-10: *****010
- Physical switch options DIP switch (1,2,3,4): *, Off, Off, On

Configuration methods for communication with a personal computer using a Windows printer driver and via Bluetooth, USB, or Serial (SPP).

- Memory switch options 1-10: *****011
- DIP switch options 1,2,3,4: *, Off, Off, Off

Configuration methods for service mode to change printer settings, load firmware, and communicate with a personal computer or via SPP.

- Memory switch options (1-10): *****011
- DIP switch options 1,2,3,4: *, Off, *, On



Bluetooth Pairing

Pair Your iOS Device

1. Enable Bluetooth on your iOS device.
2. To pair, select DPP-350 under Devices. The blue LED on the printer blinks when the devices are connected.
3. Start the Library Demo app, and then select Print self test to verify the Bluetooth connection.

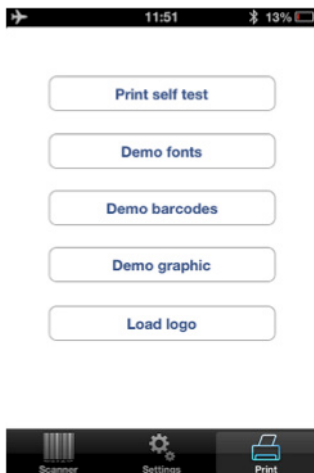

Pair Your Android Device

1. Enable Bluetooth, and then search for available devices.
2. Once DPP-350 is displayed under Available devices, you can pair it, and tap 0000 as the default pin.
3. After pairing is successful, open the Printer Sample app.
4. Select a device to connect either by tapping the Bluetooth address for the DPP-350 or scan for devices.
5. To test the Bluetooth connection, tap Print self test.

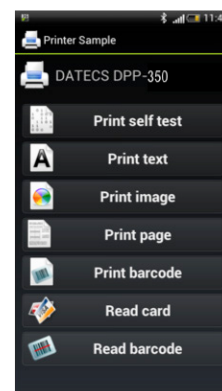
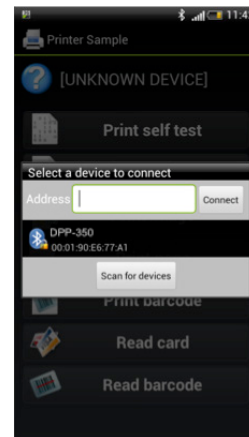
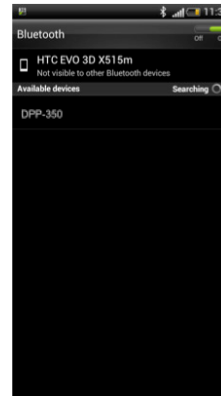



(Optional) Magnetic Stripe Reader

The built-in magnetic card reader incorporates a 3-track magnetic read head requiring a single swipe to capture field data from all three tracks. The magnetic card reader is in the front of the printer.

Before using the magnetic strip reader, you must install the software to read and process the card data. Contact your Infinite Peripherals or refer to <https://developer.ipcmobile.com/>

1. To read a magnetic stripe card, place the card with the stripe facing backwards.
2. To ensure the stripe passes over the read head evenly.
3. Keep the bottom edge of the card flat on the inner base of the reader.
4. Swipe the card evenly from start to finish, with the speed of the swipe consistent to accurately read the data on the card.

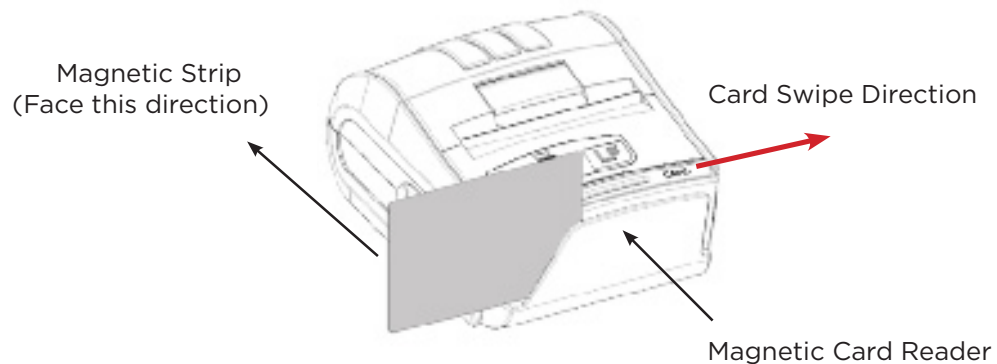



Resident Command Set

Command	Command
1 BLE Sounds Buzzer	41 ESC D Set horizontal tab position
2 HT Horizontal Tab	42 ESC E Set/cancel emphasized mode
3 LF Print a line/Paper feed	43 ESC F Fill/invert page are page mode
4 FF Print/paper to black mark position	44 ESC G Set/cancel double-strike mode
5 CR Based on flags 2,3,4	45 ESC I Set/cancel italic print
6 DC2= Image LSB/MSB selected	46 ESC J Print paper feed n/203"
7 DC3(Start Ruled Line Sequence	47 ESC L Set page mode
8 DC3+ Ruled line On	48 ESC N Read programmed serial #
9 DC3- Ruled line Off	49 ESC R Select country
10 DC3A Ruled Line A	50 ESC S Set serial port bps speed
11 DC3B Ruled Line B	51 ESC T Print short self-test
12 DC3C Clear ruled line buffer	52 ESC U Set/cancel underlined printing
13 DC3D Set single dot in ruled line buffer	53 ESC V Set/cancel 90° right turned char print
14 DC3 F Ruled line pattern set	54 ESC W Set max print speed
15 DC3 L Ruled line set	55 ESC Y Set intensity level
16 DC3 M Ruled line combination mode	56 ESC X Set maximum print speed
17 DC3 P Ruled line 1 dot line print	57 ESC Z Return diagnostic data
18 DC3 p Ruled line n dots line print	58 ESC \ Set relative horz position
19 DC3 v Ruled line image write	59 ESC] Load default settings from flash memory
20 CAN Canceling print job in page mode	60 ESC ^ Save current settings in flash memory
21 ESC FF Print data in page mode	61 ESC_ Load factory settings
22 ESC RS Buzzer sounds	62 ESC Read battery voltage/thermal head temp
23 ESC SP Set character spacing	63 ESC a Align characters
24 ESC # Set Euro symbol position	64 ESC b Print increase text line height
25 ESC \$ Specify absolute horizontal print position	65 ESC c5 Enable/disable LF button
26 ESC % Set/cancel download printing char set	66 ESC d Print/feed paper by n-lines
27 ESC & Set/cancel character set	67 ESC i Feed paper backwards
28 ESC ! Specify text print mode	68 ESC o Temp feed paper forward
29 ESC * Print graphics	69 ESC pair= Enable/disable pairing/save BT mode
30 ESC + Switch off the printer	70 ESC pwd= Program new BT PIN
31 ESC - Set/cancel underlining	71 ESC r Full command for buzzer
32 ESC . Print self-test/diagnostics	72 ESC s Read printer settings
33 ESC 2 Specify 1/6" line feed rate	73 ESC u Set code table
34 ESC 3 Specify line feed rate n/203"	74 ESC v Transmit printer status
35 ESC < Change to opposite print direction	75 ESC x Set time interval automatically turn off printer
36 ESC = Data input control	76 ESC y Set USB response strings
37 ESC > Set print direction	77 ESC { Set/cancel 180° turned characters print
38 ESC ? Read magnetic stripe card	78 GS FF Print page mode/return to standard mode
39 ESC @ Initialize printer	79 GS \$ Specify page mode absolute vertical position
40 ESC CAL Black mark mode sensor calibration	80 GS) Set printer flags/memory switches



Resident Command Set

Command	Asian Language Support Commands
81 GS / Print downloaded bit image	106 FS ! Set 2-byte text data print mode
82 GS * Define downloaded bit image	107 FS & Select 2-byte text mode (JIS or GB2312)
83 GS : Start/end macro definitions	108 FS - Set/cancel 2-byte underline text mode
84 GS B Enable/disable inverse white/black print	109 FS . Cancel 2-byte text mode
85 GS C Read realtime clock	110 FS C Set shift-JIS mode - Japanese version only
86 GS H Set HRI code print position	111 FS S Set 2-byte character spacing text mode
87 GS L Set left margin	112 FS W Set 2-byte double size character text mode
88 GS Q Print 2D barcodes	
89 GS R Fill/invert page mode rectangle	
90 GS S Set 2D barcode cell size	
91 GS T Set page mode print direction	
92 GS U Set standard mode	
93 GS W Set print area width	
94 GS X Draw standard thickness page mode rectangle box	
95 GS Z Print page mode non-blank page area	
96 GS \ Set page mode relative vertical position	
97 GS ^ Execute macro	
98 GS c Set realtime clock	
99 GS f Set HRI char barcode font	
100 GS h Set barcode height	
101 GS k Print barcode	
102 GS p Set PDF417 2D barcode	
103 GS q Set 2D barcode PDF 417 module height	
104 GS w Set barcode scale factor/horizontal size	
105 GS x Page mode direct text print	



Troubleshooting

These troubleshooting guidelines can assist you in the successful installation and configuration of the DPP-350 mobile printer. If you are having problems operating your printer, first verify that there is power to the printer and that it is powered on and sufficiently charged.

Once power and proper battery charge is confirmed, review Troubleshooting for additional information. If a problem persists or the problem is not described here, contact technical support at <https://ipcmobile.com/support>. Your unit may need to be returned for servicing.

Refer to [Charging Your DPP-350](#) for additional information on charging your printer.

Problem	Reason / Solution
Paper feeds after print job command but text not visible on paper.	Thermal paper may not be loaded with coating on outside of the roll. Remove paper roll and then reload correctly. Refer to the Installing a Paper Roll section for details.
ERR LED blinks red continuously.	Paper cover may not be install properly. Printer may be out of paper or not loaded correctly.
Text and/or images are printed too lightly.	Battery voltage may be low. Refer to Charging Battery Pack. Verify thermal paper is the recommended media.
Non-standard characters print.	Battery voltage is low. Refer to the section, Charging Your DPP-350 .
Printer does not respond to print/paper feed commands.	Reset printer: Remove battery for 5 seconds, and then reinstall battery into printer.
Text is too light to read or text is missing on half of the printed width.	Paper cover is not installed properly. Refer to the Installing a Paper Roll section for details. Printer components are loose. Contact https://ipcmobile.com/support

Servicing Your Printer

When your printer requires servicing of any type, contact your Infinite Peripherals account manager.

Important

Do not attempt to disassemble or repair your printer, AC adapter, or power cord as this can void your warranty. Refer to Product Returns and Servicing for information.

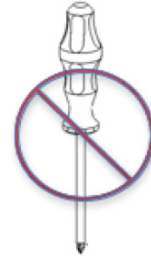

Product Returns & Servicing

Use the link in step 1 to create an account and gain access to our Knowledge Base and online support services. Through our online support center, you'll be able to download files, open a Support Ticket, manage your RMAs, view your account Profile and subscribe to Alerts.

To request a RMA

1. Create a user account in the RMA Support Portal at <http://ipcmobile.com/support/rma/>
2. Login to your user account, and then click Create RMA Request.
3. Read the instructions provided and complete the online request form.
4. Note the assigned RMA number and write it clearly on your shipping carton.
5. Ship your equipment back to us using the address provided.



Disclaimer









NO WARRANTY. This technical documentation is provided AS-IS. Further, the documentation does not represent a commitment on the part of. Infinite Peripherals, Inc does not warrant that it is accurate, complete or error free. Any use of the technical documentation is at the risk of the user. Infinite Peripherals, Inc reserves the right to make changes in specifications and other information contained in this document without prior notice, and the reader should in all cases consult Infinite Peripherals, Inc to determine whether any such changes have been made. Infinite Peripherals, Inc shall not be liable for technical or editorial errors or omissions contained herein; nor for incidental or consequential damages resulting from the furnishing, performance, or use of this material. Infinite Peripherals, Inc does not assume any product liability arising out of or in connection with the application or use of any product or application described herein.

Warranty

Infinite Peripherals does not warrant, and is not responsible for, any damage to the DPP-350 ("Product") as a result of liquid or solid particle intrusion into the Product, or damaged caused by dropping the Product with the assembled iOS device. If a material or workmanship defect arises with regard to any Infinite Peripherals product, and a valid claim is received within the Warranty Period, Infinite Peripherals (at our sole discretion) will repair the Product using new or refurbished parts, or replace the Product with a new or refurbished Product.

For purposes of this limited warranty, "refurbished" means a product or part that has been substantially returned to its original specifications. In the event of a defect, these are your exclusive remedies.

Symbols

Symbol	Description
	Refer to the instructions before using this product
	Manufacturer
	Manufacture Date
	Caution
	Serial Number
	Part Number
	Waste Electrical and Electric Equipment
	Complies with part 15 of the FCC rules



Federal Communications Commission

Federal Communications Commission (FCC) Statement

15.21

You are cautioned that changes or modifications not expressly approved by the part responsible for compliance could void the user's authority to operate the equipment.

15.105(b)

This equipment has been tested and found to comply with the limits for a Class B digital device, pursuant to part 15 of the FCC rules. These limits are designed to provide reasonable protection against harmful interference in a residential installation. This equipment generates, uses and can radiate radio frequency energy and, if not installed and used in accordance with the instructions, may cause harmful interference to radio communications. However, there is no guarantee that interference will not occur in a particular installation. If this equipment does cause harmful interference to radio or television reception, which can be determined by turning the equipment off and on, the user is encouraged to try to correct the interference by one or more of the following measures:

- Reorient or relocate the receiving antenna.
- Increase the separation between the equipment and receiver.
- Connect the equipment into an outlet on a circuit different from that to which the receiver is connected.
- Consult the dealer or an experienced radio/TV technician for help.

Operation is subject to the following two conditions:

1. This device may not cause interference

and
2. This device must accept any interference, including interference that may cause undesired operation of the device.

FCC RF Radiation Exposure Statement

This equipment complies with FCC radiation exposure limits set forth for an uncontrolled environment. End users must follow the specific operating instructions for satisfying RF exposure compliance. This transmitter must not be co-located or operating in conjunction with any other antenna or transmitter.