

Intel[®] Server System H2000JF Family Service Guide

A Guide for Technically Qualified Assemblers of Intel[®] Identified Subassemblies/Products

Order Number: G42283-002

Disclaimer

Disclaimer

Information in this document is provided in connection with Intel® products. No license, express or implied, by estoppel or otherwise, to any intellectual property rights is granted by this document. Except as provided in Intel's Terms and Conditions of Sale for such products, Intel assumes no liability whatsoever, and Intel disclaims any express or implied warranty, relating to sale and/or use of Intel products including liability or warranties relating to fitness for a particular purpose, merchantability, or infringement of any patent, copyright or other intellectual property right. Intel products are not designed, intended or authorized for use in any medical, life saving, or life sustaining applications or for any other application in which the failure of the Intel product could create a situation where personal injury or death may occur. Intel may make changes to specifications and product descriptions at any time, without notice.

Intel server boards contain a number of high-density VLSI and power delivery components that need adequate airflow for cooling. Intel's own chassis are designed and tested to meet the intended thermal requirements of these components when the fully integrated system is used together. It is the responsibility of the system integrator that chooses not to use Intel developed server building blocks to consult vendor datasheets and operating parameters to determine the amount of airflow required for their specific application and environmental conditions. Intel Corporation can not be held responsible if components fail or the server board does not operate correctly when used outside any of their published operating or non-operating limits.

Intel, Intel Pentium, and Intel Xeon are trademarks or registered trademarks of Intel Corporation or its subsidiaries in the United States and other countries.

* Other names and brands may be claimed as the property of others.

Copyright © 2011 Intel Corporation. All Rights Reserved.

Safety Information

Important Safety Instructions

Read all caution and safety statements in this document before performing any of the instructions. See also Intel Server Boards and Server Chassis Safety Information on the Intel® Server Deployment Toolkit 3.0 CD and/or at <http://www.intel.com/support/motherboards/server/sb/cs-010770.htm>.

Wichtige Sicherheitshinweise

Lesen Sie zunächst sämtliche Warnung und Sicherheitshinweise in diesem Dokument, bevor Sie eine der Anweisungen ausführen. Beachten Sie hierzu auch die Sicherheitshinweise zu Intel-Serverplatinen und Servergehäusen auf der Intel® Server Deployment Toolkit 3.0 CD oder unter <http://www.intel.com/support/motherboards/server/sb/cs-010770.htm>.

Consignes de sécurité

Lisez attention toutes les consignes de sécurité et les mises en garde indiquées dans ce document avant de suivre toute instruction. Consultez Intel Server Boards and Server Chassis Safety Information sur le Intel® Server Deployment Toolkit 3.0 CD ou bien rendez-vous sur le site <http://www.intel.com/support/motherboards/server/sb/cs-010770.htm>.

Instrucciones de seguridad importantes

Lea todas las declaraciones de seguridad y precaución de este documento antes de realizar cualquiera de las instrucciones. Vea Intel® Server Boards and Server Chassis Safety Information en el Intel® Server Deployment Toolkit 3.0 CD y/o en <http://www.intel.com/support/motherboards/server/sb/cs-010770.htm>.

重要安全指导

在执行任何指令之前，请阅读本文档中的所有注意事项及安全声明。和/或 <http://www.intel.com/support/motherboards/server/sb/cs-010770.htm> 上的 *Intel® Server Boards and Server Chassis Safety Information*（《Intel® 服务器主板与服务器机箱安全信息》）。

Warnings

Heed safety instructions: Before working with your server product, whether you are using this guide or any other resource as a reference, pay close attention to the safety instructions. You must adhere to the assembly instructions in this guide to ensure and maintain compliance with existing product certifications and approvals. Use only the described, regulated components specified in this guide. Use of other products/components will void the UL listing and other regulatory approvals of the product and will most likely result in noncompliance with product regulations in the region(s) in which the product is sold.

System power on/off: The power button DOES NOT turn off the system AC power. To remove power from the system, you must unplug the AC power cord from the wall outlet. Make sure the AC power cord is unplugged before you open the chassis, add, or remove any components.

Hazardous conditions, devices and cables: Hazardous electrical conditions may be present on power, telephone, and communication cables. Turn off the server and disconnect the power cord, telecommunications systems, networks, and modems attached to the server before opening it. Otherwise, personal injury or equipment damage can result.

Electrostatic discharge (ESD) and ESD protection: ESD can damage disk drives, boards, and other parts. We recommend that you perform all procedures in this chapter only at an ESD workstation. If one is not available, provide some ESD protection by wearing an antistatic wrist strap attached to chassis ground—any unpainted metal surface—on your server when handling parts.

ESD and handling boards: Always handle boards carefully. They can be extremely sensitive to ESD. Hold boards only by their edges. After removing a board from its protective wrapper or from the server, place the board component side up on a grounded, static free surface. Use a conductive foam pad if available but not the board wrapper. Do not slide board over any surface.

Installing or removing jumpers: A jumper is a small plastic encased conductor that slips over two jumper pins. Some jumpers have a small tab on top that you can grip with your fingertips or with a pair of fine needle nosed pliers. If your jumpers do not have such a tab, take care when using needle nosed pliers to remove or install a jumper; grip the narrow sides of the jumper with the pliers, never the wide sides. Gripping the wide sides can damage the contacts inside the jumper, causing intermittent problems with the function controlled by that jumper. Take care to grip with, but not squeeze, the pliers or other tool you use to remove a jumper, or you may bend or break the pins on the board.

Preface

About this Manual

This manual is written for system technicians who are responsible for troubleshooting, upgrading, and repairing this server system. This document provides a brief overview of the features of the server board/chassis, a list of accessories or other components you may need, troubleshooting information, and instructions on how to add and replace components on the Intel® Server System H2000JF family products. For the latest revision of this manual, go to http://www.intel.com/p/en_US/support.

Table 1. Intel® Server System H2000JF family product list

Product Code	Description
Intel® Server System H2312JFJR	With four S2600JF boards, 12 x 3.5" hard drive bay, 2 x 1200W CRPS
Intel® Server System H2216JFJR	With four S2600JF boards, 16 x 2.5" hard drive bay, 2 x 1200W CRPS
Intel® Server System H2312JFQJR	With four S2600JFQ boards, 12 x 3.5" hard drive bay, 2 x 1200W CRPS
Intel® Server System H2216JFQJR	With four S2600JFQ boards, 16 x 2.5" hard drive bay, 2 x 1200W CRPS
Intel® Server System H2312JFFJR	With four S2600JFF boards, 12 x 3.5" hard drive bay, 2 x 1200W CRPS
Intel® Server System H2216JFFJR	With four S2600JFF boards, 16 x 2.5" hard drive bay, 2 x 1200W CRPS
Intel® Server System H2312JFKR	With four S2600JF boards, 12 x 3.5" hard drive bay, 2 x 1600W CRPS
Intel® Server System H2216JFKR	With four S2600JF boards, 16 x 2.5" hard drive bay, 2 x 1600W CRPS
Intel® Server System H2312JFQKR	With four S2600JFQ boards, 12 x 3.5" hard drive bay, 2 x 1600W CRPS
Intel® Server System H2216JFQKR	With four S2600JFQ boards, 16 x 2.5" hard drive bay, 2 x 1600W CRPS
Intel® Server System H2312JFFKR	With four S2600JFF boards, 12 x 3.5" hard drive bay, 2 x 1600W CRPS
Intel® Server System H2216JFFKR	With four S2600JFF boards, 16 x 2.5" hard drive bay, 2 x 1600W CRPS

Manual Organization

Chapter 1 provides a brief overview of the Intel® Server System H2000JF family. In this chapter, you will find a list of the server system features, and figures of the system and components to help you identify your system components and their locations.

Chapter 2 provides instructions on adding and replacing components. Use this chapter for step-by-step instructions and diagrams for installing or replacing components such as the fan, power supply, and front panel board, among other components.

Chapter 3 provides instructions on using the utilities that are shipped with the board or that may be required to update the system. This includes information for navigating through the BIOS Setup screens, performing a BIOS update, and resetting the password or BIOS defaults.

At the back of this document, you will find appendices on safety, "Getting Help", and warranty information.

Additional Information and Software

For additional information about this family of products or any of their supported accessories, refer to the following resources available at <http://www.intel.com/support>.

Table 2. Server System References

For this information or software	Use this Document or Software
For in-depth technical information about this product.	<i>Intel® Server System H2000JF Family Technical Product Specification</i> See the section on the web page titled, “Architecture/Specifications”.
For installation of supported spares and accessories	<i>Intel® Server System H2000JF Family Quick Installation User’s Guide</i> See the section on the web page titled, “System Integration/User Guides/Compatibility”.
For a list of supported Intel spares and accessories	<i>Spares and Configuration Guide</i> See the section on the web page titled, “Documents & Guides”.
For server configuration guidance and compatibility	Intel® Server Configurator tool To be provided later.
For system power budget guidance	Power Budget Analysis Tool To be provided later.
For software to manage your Intel® Server System.	Intel Server Management Software See the section on the web page titled, “Software/Code”.
For system firmware updates and onboard device drivers	Intel Deployment Assistant DVD Firmware and Drivers See the section on the web page titled, “Software/Code”.
Product Safety and Regulatory document	<i>Intel Server Products - Product Safety and Regulatory Compliance Document</i> See the section on the web page titled, “Regulations/Certification/Compliance”.

Table of Contents

Safety Information	iii
Preface	v
1 Server System Features	1
Server System Feature Overview	1
Server System Components.....	3
Front Panel	5
Back Panel.....	5
Server Board Components.....	6
Intel® Light-Guided Diagnostics	7
System Recovery Jumpers.....	8
Hard Disk Drive Carriers.....	9
Bezel	9
Hot-Swap SAS/SATA Backplane	10
Advanced Management Options.....	12
2 Hardware Installations and Upgrades	13
Before You Begin.....	13
Tools and Supplies Needed	13
System Reference	13
Cable Routing.....	14
For cable connection inside Node tray:	14
Removing and Installing the Front Bezel.....	14
Removing the Front Bezel.....	14
Installing the Front Bezel	15
Removing and Installing the System Top Cover.....	15
Removing the System Top Cover.....	15
Installing the System Cover.....	16
Removing and Installing the Compute Node Tray	17
Removing the Node Tray.....	17
Installing the Node Tray	18
Removing and Installing the Redundant Power Supply Unit.....	18
Removing the Power Supply Unit	18
Installing the Power Supply Unit.....	19
Removing and Installing the Node Tray Air Duct	19
Removing the Air Duct.....	19
Installing the Air Duct	20
Transparent Mylar Installation	21
Removing and Installing Processor	22
Removing Processor Heatsink(s).....	22
Installing the Processor.....	23
Installing Processor Heatsink(s)	25
Removing the Processor	26
Installing and Removing Memory.....	26
Installing Memory	26
Removing Memory.....	27

Table of Contents

Installing and Removing Hot-swap Hard Drive	27
Installing a Hard Disk Drive into 3.5" Hard Drive Carrier	27
Installing a Hard Disk Drive into 2.5" Hard Drive Carrier	28
Installing and Removing the PCIe Riser Assembly	29
On Riser Slot 1	29
Installing the PCI Riser Assembly and add-in card	29
Removing a PCI Add-in Card	30
On Riser Slot 2	32
Installing IOM riser and carrier assembly	32
Removing IO module	33
Installing and Removing the Intel® Remote Management Module 4 Lite	35
Installing the Intel® RMM4 Lite	35
Installing the Intel® Storage Upgrade Key	36
Installing the Intel® Storage Upgrade Key	36
Installing and Removing the Bridge Board	37
Removing the Bridge Board	37
Installing the Bridge Board	37
Installing and Removing the Node Power Docking Board	38
Removing the NPD Board	38
Installing the NPD Board	39
Installing and Removing the Fan set in node tray	40
Removing the Fan set	40
Installing the Fan set	41
Installing and Removing the 2.5" Backplane Board	41
Removing the 2.5" Backplane board	41
Installing the Server Board	42
Installing and Removing the 3.5" Backplane Board	43
Removing the 3.5" Backplane board	43
Installing the Server Board	44
Installing and Removing the Power Distribution Board	45
Removing the PDB	45
Installing the PDB	46
Replacing the Backup Battery	48
Replacing the Front Control Panel board	49
Removing the Front Control Panel	49
Installing Front Control Panel Board	50
Rack Mounting the Chassis	51
Mounting the Chassis to Rack	51
Removing the Chassis from Rack	54
3 Server Utilities	55
Using the BIOS Setup Utility	55
Starting Setup	55
Setup Navigation Keyboard Commands	55
Setup Screen Menu Selection Bar	56
BIOS Setup Utility Screens	56
Map of Screens and Functionality	57
Appendix A: Technical Reference	59
Power Supply Input Voltages	59
Power Supply Output Voltages	59

System Environmental Specifications	59
Appendix B: Regulatory and Compliance Information	61
Appendix C: LED Decoder	62
Appendix D: Getting Help.....	68
Warranty Information	68
Appendix E: Intel® Server Issue Report Form.....	69

List of Figures

Figure 1. Intel® Server System H2000JF Family (H2312JF as demonstrated).....	1
Figure 2. Intel® Server System H2000JF Overview (H2312JF as Demonstrated)	3
Figure 3. Front View of Intel® Server System H2312JF with 12x3.5” HDD bays.....	4
Figure 4. Front View of Intel® Server System H2216JF with 16x2.5” HDD bays.....	4
Figure 5. Rear View of Intel® Server System H2000JF with Compute Node Numbering	4
Figure 6. HDD array scheme on Intel® Server System H2312JF	4
Figure 7. HDD array scheme on Intel® Server System H2216JF	5
Figure 8. Front Panel Options	5
Figure 9. Back Panel Feature Identification per Compute Node	6
Figure 10. Server Board Connector and Component Locations	6
Figure 11. Intel® Light-Guided Diagnostic LEDs - Server Board	7
Figure 12. Configuration Jumpers	9
Figure 13. Front view of System Bezel.....	9
Figure 14. 12 x 3.5-inch Hard Drive Backplane Components (Front View).....	10
Figure 15. 12 x 3.5-inch Hard Drive Backplane Components (Rear View)	11
Figure 16. 16 x 2.5-inch Hard Drive Backplane Components (Front View).....	11
Figure 17. 16 x 2.5-inch Hard Drive Backplane Components (Rear View)	12
Figure 18. Cable Routing inside Node tray.....	14
Figure 19. Removing the Front Bezel.....	15
Figure 20. Installing the Front Bezel	15
Figure 21. Removing the System Top Cover.....	16
Figure 22. Installing the System Cover.....	17
Figure 23. Pulling out the Node Tray	17
Figure 24. Installing the Node Tray	18
Figure 25. Removing the PSU	18
Figure 26. Installing the PSU.....	19
Figure 27. Removing the Air Duct.....	20
Figure 28. Installing the Air Duct	21
Figure 29. Transparent isolation film for air duct	22
Figure 30. Removing Processor Heatsink	23
Figure 31. Installing Processor – Open the Socket Lever	23
Figure 32. Installing Processor – Open the Load Plate.....	24
Figure 33. Installing Processor – Install the Processor	24
Figure 34. Installing Processor – Remove the Cover.....	24
Figure 35. Installing Processor – Close the Load Plate	25
Figure 36. Installing Processor – Latch the Locking Lever	25
Figure 37. Installing Processor Heatsink	26
Figure 38. Installing Memory	27
Figure 39. Installing Hard Disk Drive – installing 3.5” HDD to carrier.....	27
Figure 40. Installing Hard Disk Drive – Inserting 3.5” HDD assembly	28
Figure 41. Installing Hard Disk Drive – Installing 2.5” HDD to carrier.....	28
Figure 42. Installing Hard Disk Drive – Inserting 2.5” HDD assembly	29
Figure 43. Assembly riser with bracket	29
Figure 44. Plug in PCIe add-in card.....	30
Figure 45. Installing PCI Riser Assembly	30
Figure 46. Removing IOM assmby.....	31
Figure 47. Removing PCIe add-in card assembly.....	31

Figure 48. Removing PCIe add-in card from riser slot.....	32
Figure 49. Install IO module.....	32
Figure 50. Installing assembly to riser.....	33
Figure 51. Fastening the assembly in chassis.....	33
Figure 52. Remove IOM assembly.....	34
Figure 53. Removing IOM assembly from chassis.....	34
Figure 54. Removing IO module from assembly.....	35
Figure 55. Installing the Intel® RMM4 Lite.....	35
Figure 56. Installing the Intel® Storage Upgrade Key.....	36
Figure 57. Removing the bridge board.....	37
Figure 58. Installing the Bridge Board.....	38
Figure 59. Removing the NPD board.....	39
Figure 60. Installing the NPD Board.....	40
Figure 61. Removing the Node Fan set.....	40
Figure 62. Installing the Server Board.....	41
Figure 63. Removing the 2.5” backplane board.....	42
Figure 64. Align the backplane to the clamps on the chassis base.....	42
Figure 65. Installing the 2.5” backplane board.....	43
Figure 66. Removing the 2.5” backplane board.....	44
Figure 67. Align the backplane to the clamps on the chassis base.....	44
Figure 68. Installing the 2.5” backplane board.....	45
Figure 69. Removing the upper PDB.....	45
Figure 70. Removing the lower PDB.....	46
Figure 71. Installing the lower PDB.....	47
Figure 72. Installing the upper PDB.....	47
Figure 73. Replacing the Backup Battery.....	48
Figure 74. Removing FP Assembly from Rack Handle.....	49
Figure 75. Disconnecting Control Panel Cable.....	49
Figure 76. Removing Control Panel Board.....	50
Figure 77. Installing Control Panel Board.....	50
Figure 78. Connecting Cable to Front Panel Board.....	51
Figure 79. Installing Control Panel Assembly to Rack Handle.....	51
Figure 80. Installing the Chassis to Rack.....	53
Figure 81. Removing the Chassis from Rack.....	54
Figure 82. Diagnostic LED Placement Diagram.....	62

List of Tables

Table 1. Intel® Server System H2000JF family product list	v
Table 2. Server System References.....	vi
Table 3. Intel® Server System H2000JF Feature Summary	1
Table 4. Hard Disk Drive Options	9
Table 5. POST Progress Code LED Example.....	36
Table 6. BIOS Setup: Keyboard Command Bar	55
Table 7. Screen Map	57
Table 8. CRPS Input Voltage.....	59
Table 9. CRPS Output Voltage	59
Table 10. System Environmental Limits Summary	59
Table 11. POST Progress Code LED Example.....	63
Table 12. Diagnostic LED POST Code Decoder.....	63

<This page is intentionally left blank.>

1 Server System Features

This chapter briefly describes the main features of the Intel® Server System H2000JF family. This includes illustrations of the products, a list of the server system features, and diagrams showing the location of important components and connections on the server systems.

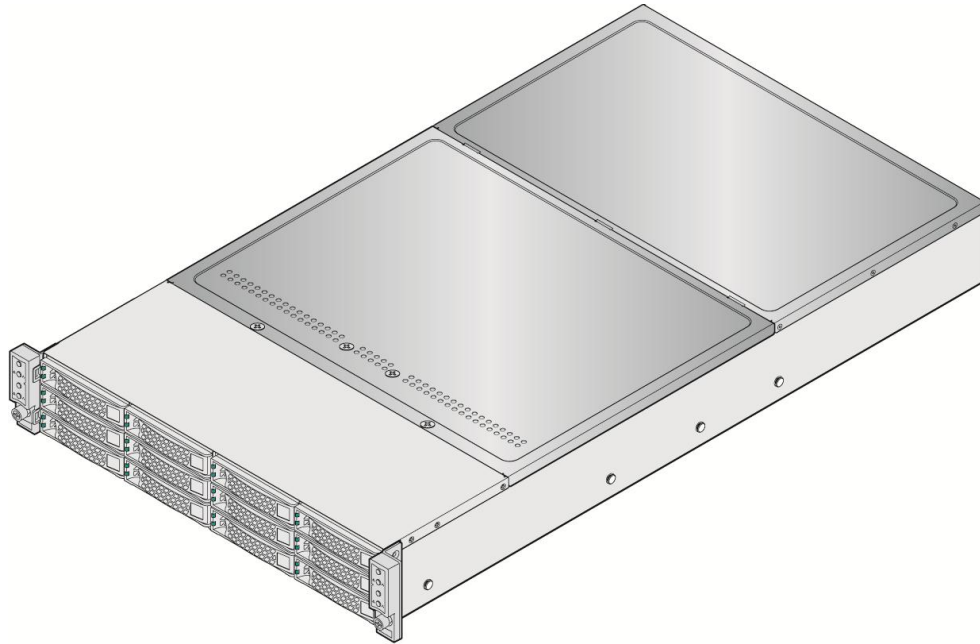

AF004655

Figure 1. Intel® Server System H2000JF Family (H2312JF as demonstrated)

Server System Feature Overview

Table 3 summarizes the features of the the server systems.

Table 3. Intel® Server System H2000JF Feature Summary

Feature		Description
Dimensions	H2312JF	<ul style="list-style-type: none"> ▪ 3.46 inches (87.9 mm) high ▪ 17.24 inches (438.0 mm) wide ▪ 30.35 inches (771 mm) deep ▪ 84 pounds (38kg) - maximum chassis weight
	H2216JF	<ul style="list-style-type: none"> ▪ 3.46 inches (87.9 mm) high ▪ 17.24 inches (438.0 mm) wide ▪ 28.86 inches (733 mm) deep ▪ 71 pounds (32kg) - maximum chassis weight
Compute Node Processor Support		<ul style="list-style-type: none"> ▪ Support for one or two Intel® Xeon® processors E5-2600 product family with a Thermal Design Power (TDP) of up to 130 W(8-core and 6-core), or 80W(4-core) and below.

Server System Features

Feature	Description
Compute Node Memory	<ul style="list-style-type: none"> ▪ 8 DIMM slots – 1 DIMMs/Channel – 4 memory channels per processor. ▪ Unbuffered DDR3 and registered DDR3 DIMMs. ▪ Memory DDR3 data transfer rates of 800, 1066, 1333 MT/s and 1600 MT/s. ▪ DDR3 standard I/O voltage of 1.5V (all speed) and DDR3 Low Voltage of 1.35V (1333MT/s or below).
Chipset on each Compute Node	Intel® C600-A chipset with support for optional Storage Upgrade Keys.
Compute Node External I/O connections	<ul style="list-style-type: none"> ▪ DB-15 Video connectors. ▪ Two RJ-45 Network Interface for 10/100/1000 LAN. ▪ One stacked two port USB 2.0 (Port 0/1) connectors. ▪ One dedicated 1GbE management port on rIOM carrier (Optional). ▪ One InfiniBand* QDR QSFP port (Board SKU: S2600JFQ) or ▪ One InfiniBand* FDR QSFP port (Board SKU: S2600JFF).
Compute Node Internal I/O connectors/headers	<ul style="list-style-type: none"> ▪ Bridge Slot to extend board I/O: <ul style="list-style-type: none"> - SCU0 (Four SAS 3Gb/s ports) to backplane. - Front control panel signals. - One SATA (Port 0) 6Gb/s port for DOM. ▪ One Type-A USB 2.0 connector (USB port 2). ▪ One 2x7pin header for system FAN module. ▪ One DH-10 serial Port A connector. ▪ One SATA 6Gb/s (Port 1). ▪ One 2x4 pin header for Intel® RMM4 Lite. ▪ One 1x4 pin header for Storage Upgrade Key.
Available I/O Module Options (Sold Separately)	<p>The following I/O modules utilize a single proprietary on-board connector. An installed I/O module can be supported in addition to standard on-board features and any add-in expansion cards:</p> <ul style="list-style-type: none"> ▪ Quad Port Intel® I350 GbE I/O Module ▪ Dual Port Intel® X540 10GbE I/O Module ▪ Dual Port Intel® 82599 10GbE I/O Module ▪ QDR InfiniBand® ConnectX® I/O Module ▪ FDR InfiniBand® ConnectX® I/O Module
System Fans by each Compute Node	<ul style="list-style-type: none"> ▪ Three sets of dual rotor managed system fans. ▪ One internal power supply fan for each installed power supply unit.
Compute Node Riser Cards	<p>Three PCIe Gen III x16 riser slots:</p> <ul style="list-style-type: none"> ▪ Riser slot 1 support PCIe Gen III x16 Riser with LP PCIe add-in card. ▪ Riser slot 2 supports PCIe Gen III x8 Riser (for Intel® rIOM and RMM4 NIC port). ▪ Riser slot 3 cannot be used with bridge board covered. ▪ One Bridge Slot for board I/O expansion.
Node Video	<ul style="list-style-type: none"> ▪ Integrated 2D Video Controller ▪ 128 MB DDR3 Memory
Node On-board storage controllers and options	<ul style="list-style-type: none"> ▪ Two single port SATA connectors (on baseboard and bridge board) capable of supporting up to 6 GB/sec. ▪ SCU0 4-port up to 3 GB/sec SAS/SATA via bridge board. ▪ Intel® RAID C600 Upgrade Key support providing optional expanded SATA/SAS RAID capabilities.
Server Management	<ul style="list-style-type: none"> ▪ Onboard ServerEngines* LLC Pilot III* Controller. ▪ Support for Intel® Remote Management Module 4 Lite solutions. ▪ Intel® Light-Guided Diagnostics on field replaceable units.

Feature	Description
	<ul style="list-style-type: none"> Support for Intel® System Management Software. Support for Intel® Intelligent Power Node Manager (Need PMBus-compliant power supply).
Power Supply Options	<ul style="list-style-type: none"> 1200w AC Common Redundant Power Supply (CRPS), 80 plus Platinum with PFC, supporting CRPS configuration. Chassis SKU: H2312JFJR, H2216JFJR. 1600w AC Common Redundant Power Supply (CRPS), 80 plus Platinum with PFC, supporting CRPS configuration. Chassis SKU: H2312JFKR, H2216JFKR.
Storage Bay Options	<ul style="list-style-type: none"> 12x 3.5-inch SATA/SAS HDD bays (SKU: H2312JF). 16x 2.5-inch SATA/SAS HDD bays (SKU: H2216JF).
Available Rack Mount Kit Options	<ul style="list-style-type: none"> Basic slide rail kit, bundled with system package.

Server System Components

This section helps you identify the components of your server system. If you are near the system, you can also use the Quick Reference Label provided on the inside of the chassis cover to assist in identifying components.

The H2000JF family is containing 4 compute nodes in the chassis. The whole system view is as below (with top cover removed).

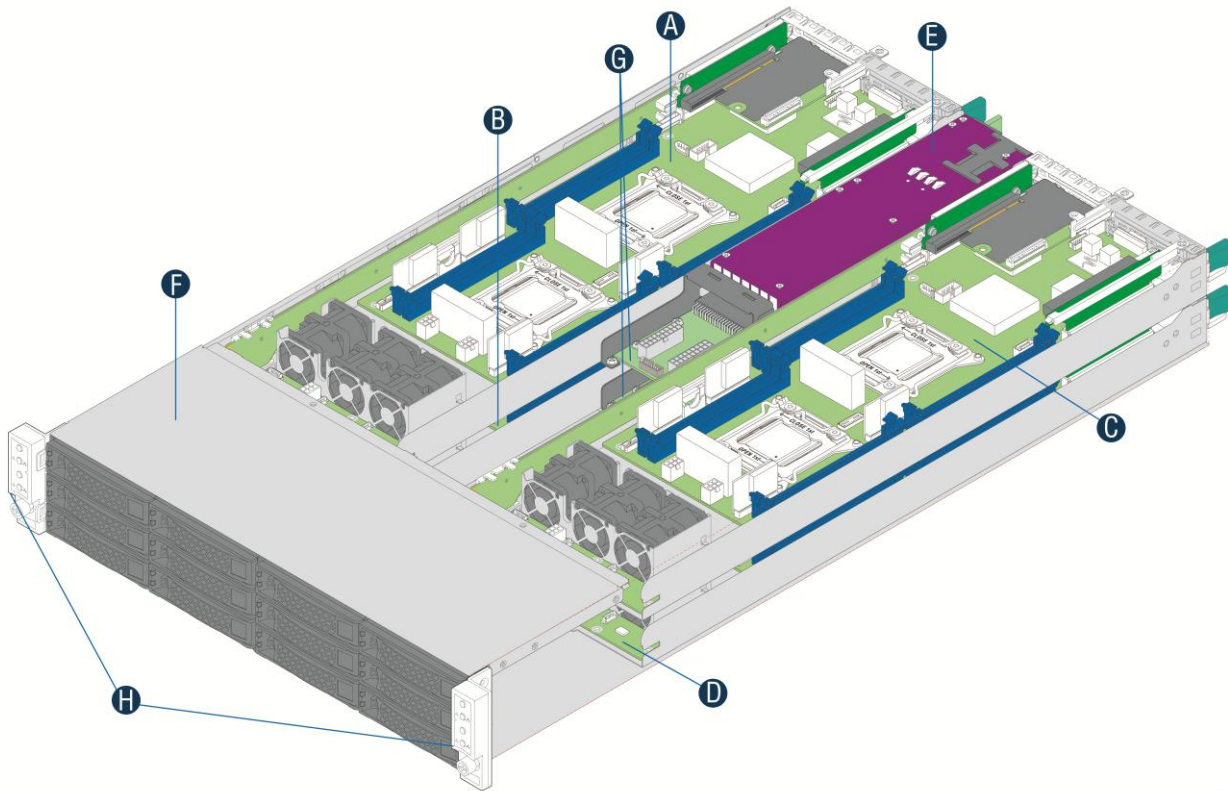

AF004510

A	Compute Node 3 Tray	E	Common Redundant Power Supply
B	Compute Node 1 Tray	F	HDD bays with Hot Swap Backplane
C	Compute Node 4 Tray	G	Upper and Lower Power Distribution Boards
D	Compute Node 2 Tray	H	Front Control Panel

Figure 2. Intel® Server System H2000JF Overview (H2312JF as Demonstrated)

Server System Features

There are two configurations of hard disk drives for H2000JF family.

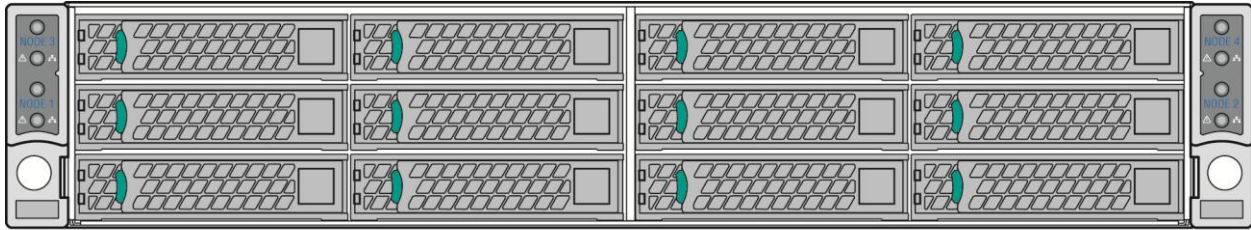

AF004635

Figure 3. Front View of Intel® Server System H2312JF with 12x3.5" HDD bays

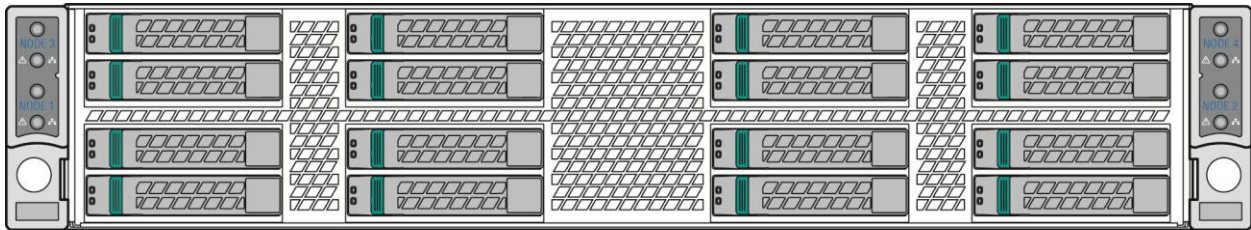

AF004637

Figure 4. Front View of Intel® Server System H2216JF with 16x2.5" HDD bays

The Compute Node in the chassis has dedicated numbering by position.

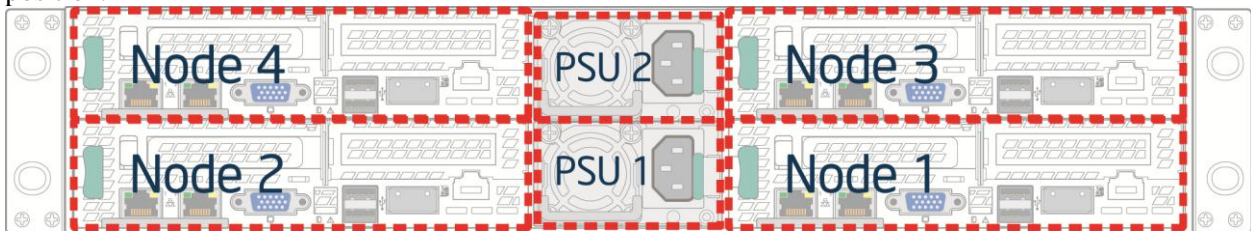

AF004513

Figure 5. Rear View of Intel® Server System H2000JF with Compute Node Numbering

Each Compute Node has dedicated Hard Disk Drive array based on backplane controller design. Below are schemes for HDD array in correspondent to Compute Node.

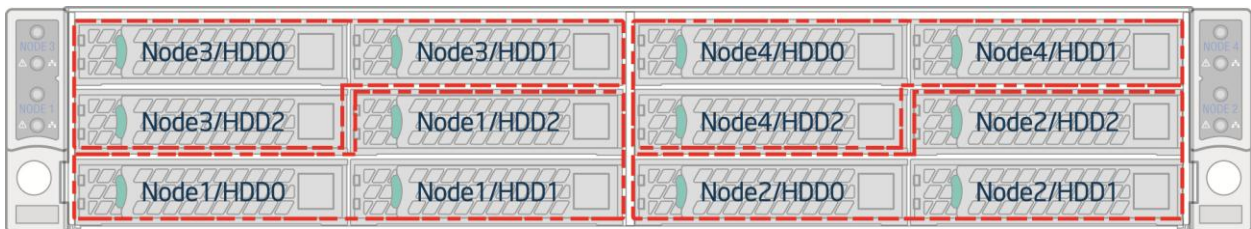

AF004511

Figure 6. HDD array scheme on Intel® Server System H2312JF

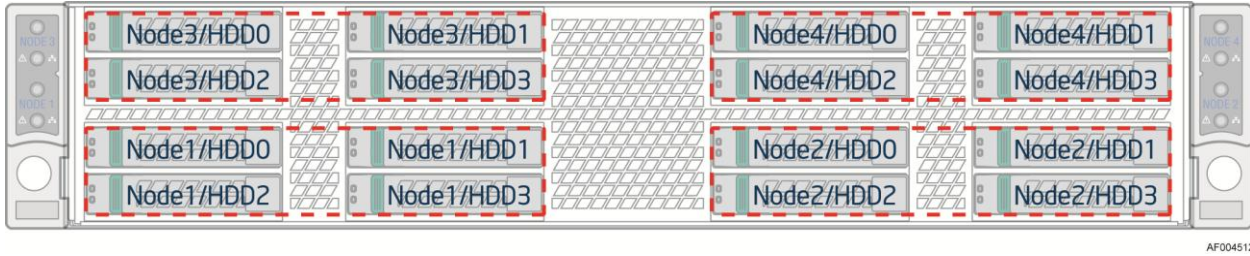
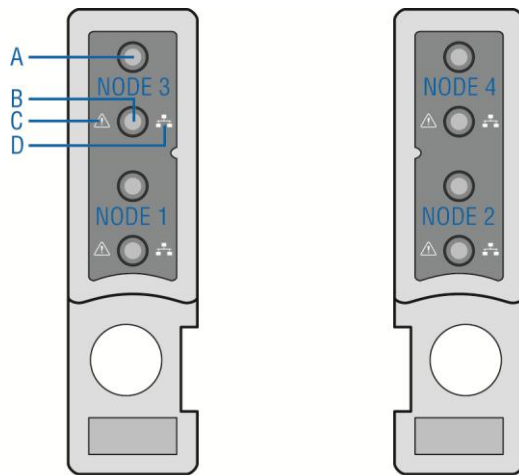

Figure 7. HDD array scheme on Intel® Server System H2216JF

Front Panel

The system contains two sets of control panels on left and right rack handles. Each control panel contains two sets of control buttons and LEDs for each Compute Node. Below is the scheme of control panel.



A	System Power Button with LED
B	System ID LED Button
C	System Status LED
D	NetworkLink/Activity LED

Figure 8. Front Panel Options

Back Panel

Compute Node back panle scheme is as below.

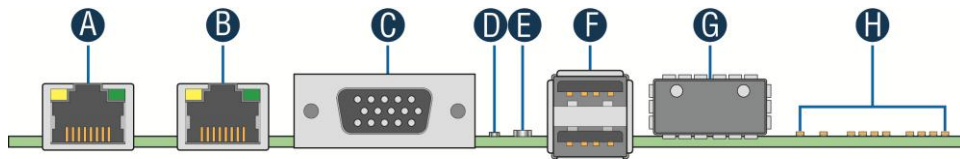

	Description		Description
A	NIC port 1 (RJ45)	E	Status LED
B	NIC port 2 (RJ45)	F	Dual port USB connector

	Description		Description
C	DB15 video out	G	QSFP Connector
D	ID LED	H	QSFP status and Diagnostic LED

Figure 9. Back Panel Feature Identification per Compute Node

Server Board Components

This section helps you identify the components and connectors on the server board in each Compute Node.

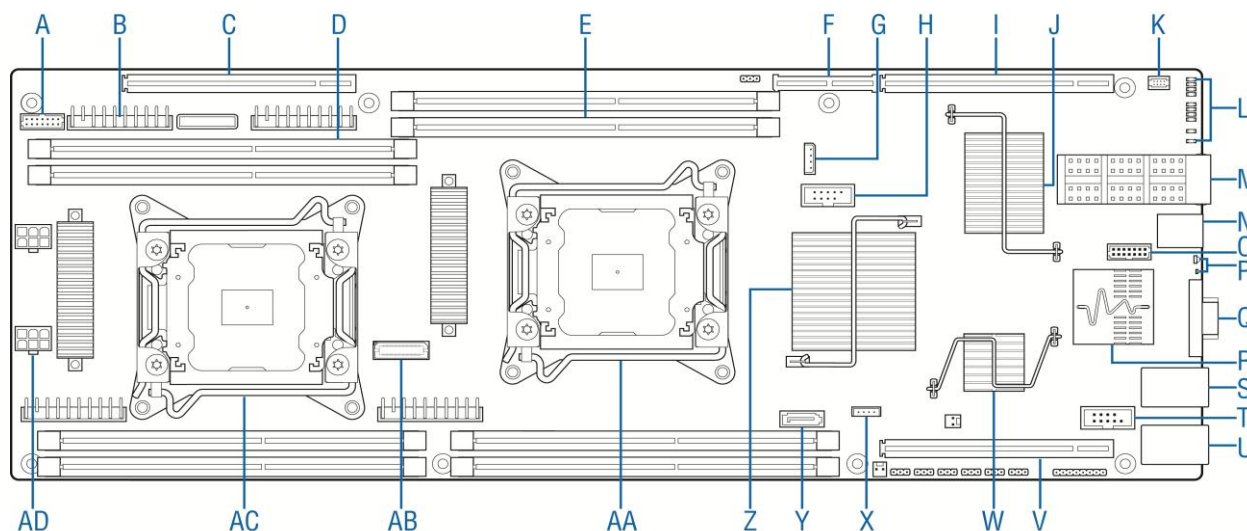

AF004220

A	2x7 fan control connector	I	Riser Slot2 with PCIe Gen3 x16	Q	VGA out	Y	SATA port 1
B	VRS (4 total)	J	Infiniband QDR or FDR	R	Dual port 1Gbe NIC	Z	PCH C600
C	Riser Slot3 with PCIe Gen3 x16	K	RMM4 lite	S	NIC Port 2	AA	CPU 1
D	CPU2 DIMM (4 total)	L	POST LED and IB Status LED	T	Serial Port A	AB	XDP connector
E	CPU1 DIMM (4 total)	M	QSFP	U	NIC Port 1	AC	CPU 2
F	Bridge board connector	N	USB x2	V	Riser Slot1 with PCIe Gen3 x16	AD	2x3 PWR connector (2 total)
G	IPMB	O	Debug connector	W	Integrated BMC		
H	2x5 USB	P	Status & ID LED	X	Storage Upgrade key		

Figure 10. Server Board Connector and Component Locations

Intel® Light-Guided Diagnostics

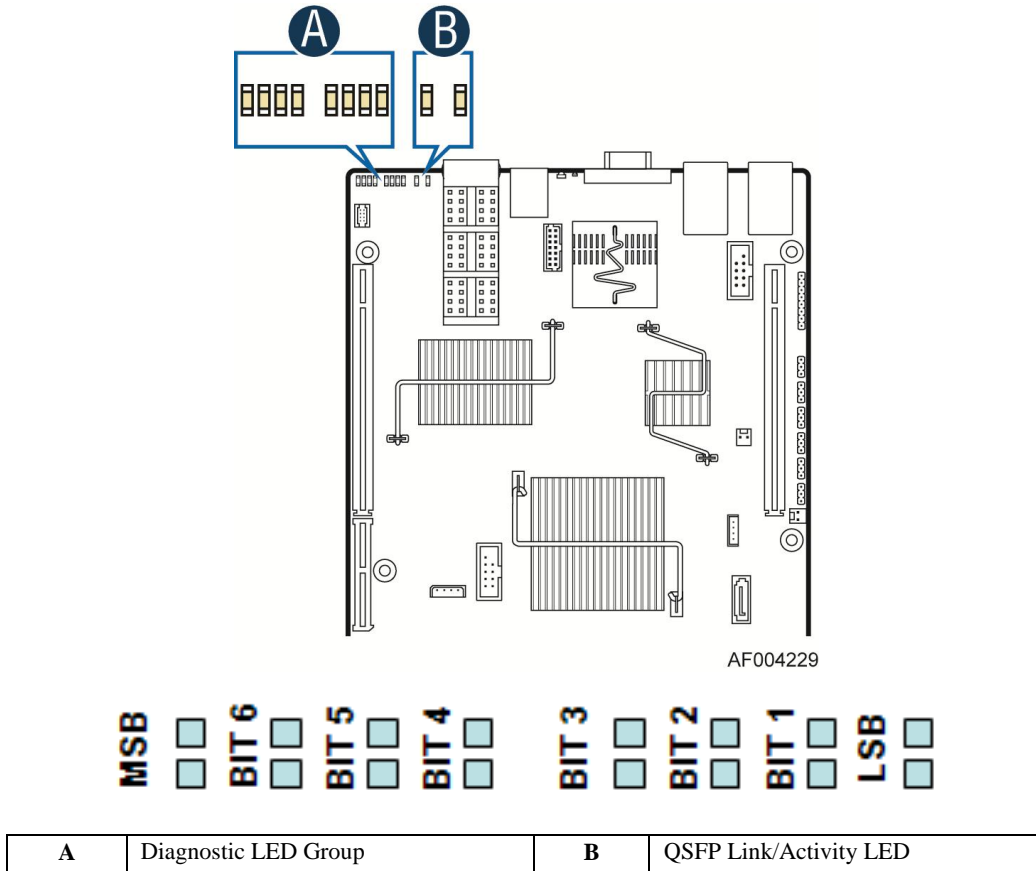

Figure 11. Intel® Light-Guided Diagnostic LEDs - Server Board

The server system contains the following diagnostic LEDs, each providing the following functions:

Section A – POST Code Diagnostic LEDs on the server board change color or state (off, green, red, amber) according to the POST sequence.

Section B – Link and Activity LEDs for QSFP Infiniband.

The System Identification LED on the front and back panel helps identify the server from among several servers. The ID LED is off by default, and blue when activated by button or software.

The System Status LED on the front and back panels shows the overall health of the system (green, blinking green, blinking amber, amber, off).

System Recovery Jumpers

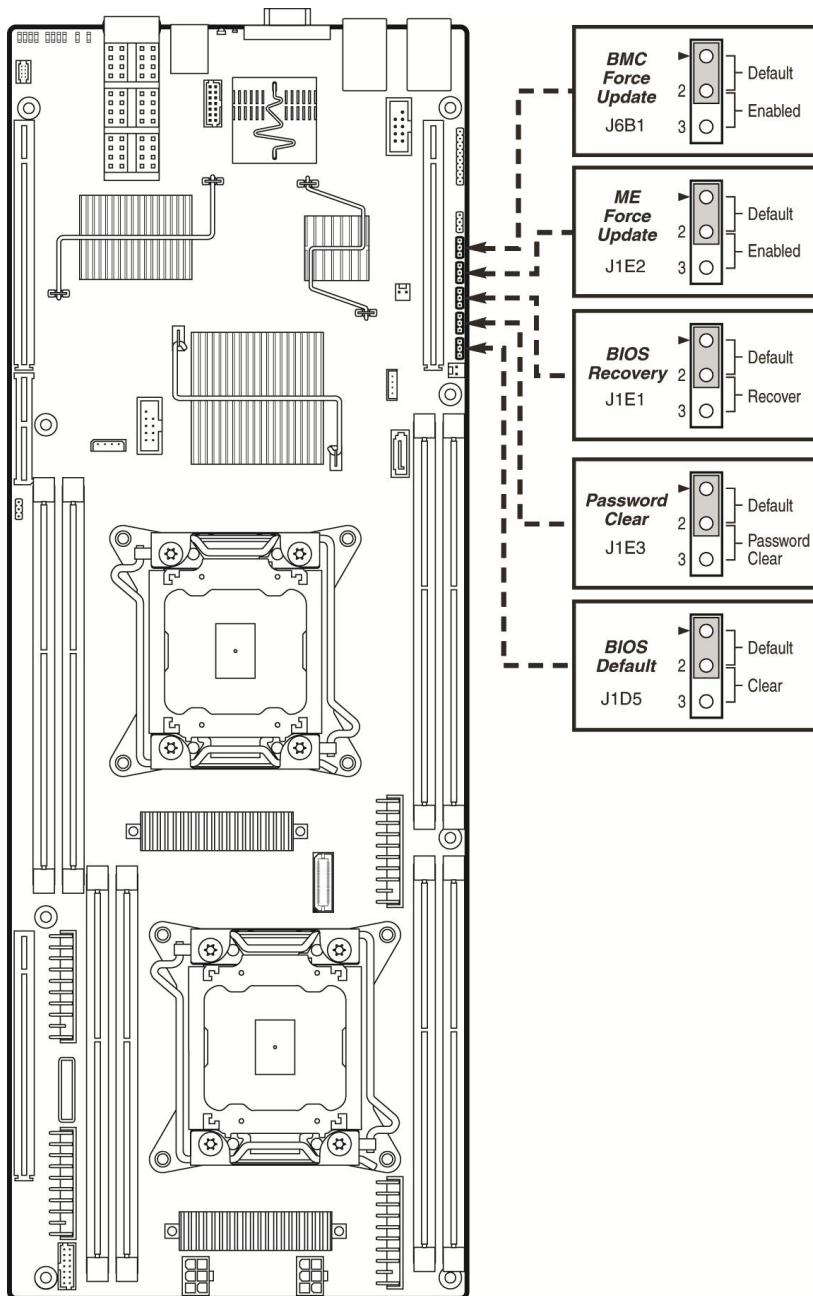

AF004227

Jumper Name	Jumper Position	Mode of Operation	Note
J6B1: BMC Force Update jumper	1-2	Normal	Normal mode
	2-3	Update	BMC in force update mode
J1E2: ME Force Update	1-2	Normal	Normal mode
	2-3	Update	ME in force update mode
J1E3: Password Clear	1-2	Normal	Normal mode, password in protection
	2-3	Clear Password	BIOS password is cleared

Jumper Name	Jumper Position	Mode of Operation	Note
J1E1: BIOS Recovery Mode	1-2	Normal	Normal mode
	2-3	Recovery	BIOS in recovery mode
J1D5: BIOS Default	1-2	Normal	Normal mode
	2-3	Clear BIOS Settings	BIOS settings are reset to factory default

Figure 12. Configuration Jumpers

Hard Disk Drive Carriers

The Intel® Server System JF ships in two different basic SKUs, and with different maximum number of hard disk drives, see Table 2 for details :

Table 4. Hard Disk Drive Options

Intel® Server System	Supported Hard Drive Type	Maximum Hard Drive Number
H2312JF	3.5-inch or 2.5-inch	12
H2216JF	2.5-inch	16

Note: SAS drives are only supported when proper Intel® RAID C600 Upgrade Key is installed.

Note: Drives can consume up to 17 watts of power each. Drives must be specified to run at a maximum ambient temperature of 45°C.

Note: The Intel® Server System H2000JF does not support all SAS or Serial ATA (SATA) hard drives. For a web link to a list of supported hard drives, see [Additional Information and Software](#).

Bezel

The front bezel is available as optional accessory for the server system:

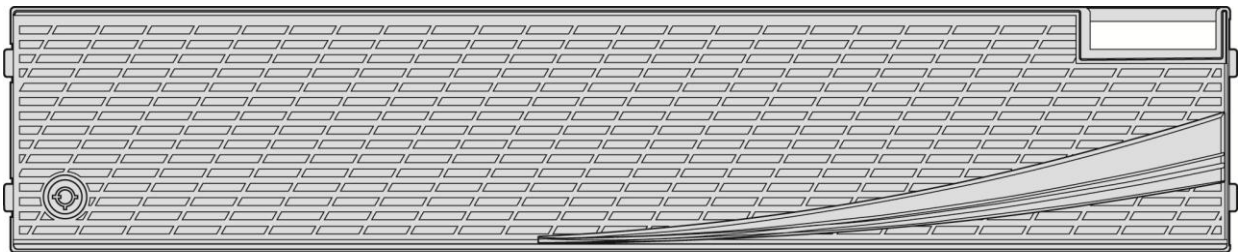

AF004476

Figure 13. Front view of System Bezel

Hot-Swap SAS/SATA Backplane

The Hot-Swap SAS/SATA backplane serves as an interface between the mother board and the system drives. The following diagrams show the location for each connector found on the backplane.

12 x 3.5-inch Hard Drive Backplane

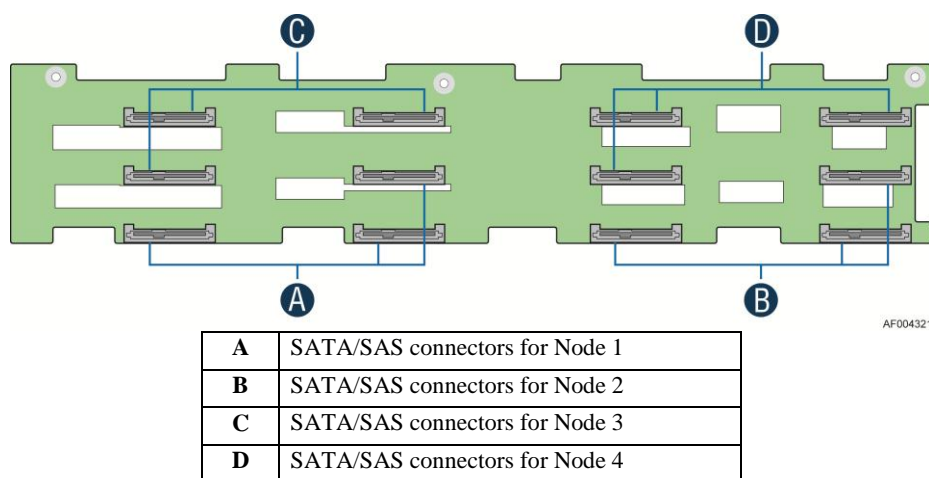
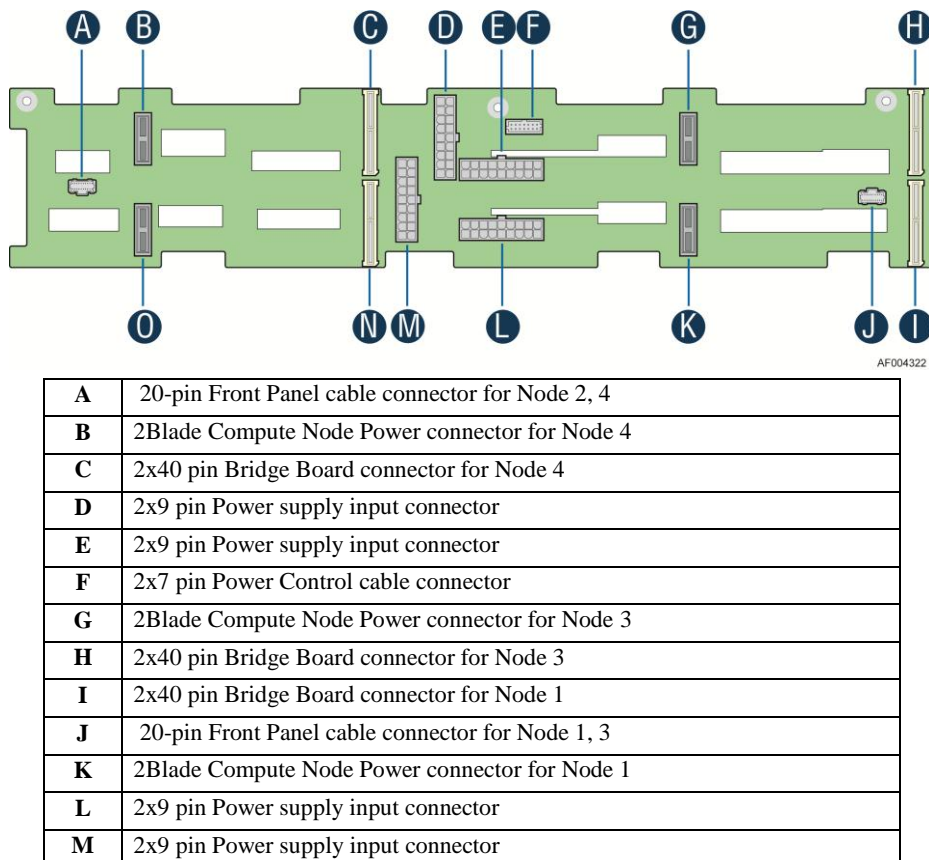

Figure 14. 12 x 3.5-inch Hard Drive Backplane Components (Front View)



N	2x40 pin Bridge Board connector for Node 2
O	2Blade Compute Node Power connector for Node 2

Figure 15. 12 x 3.5-inch Hard Drive Backplane Components (Rear View)

16 x 2.5-inch Hard Drive Backplane

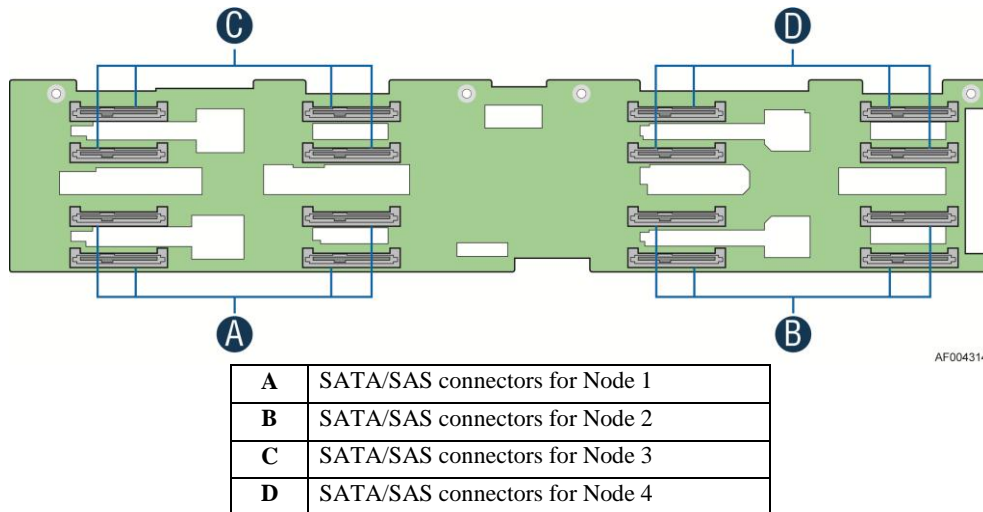
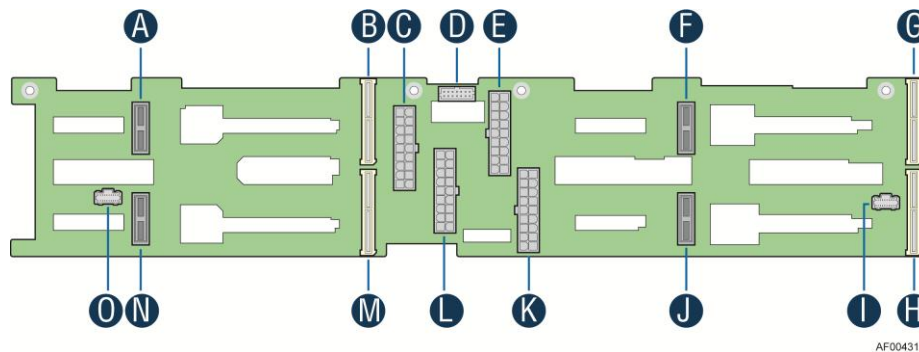

Figure 16. 16 x 2.5-inch Hard Drive Backplane Components (Front View)



A	2Blade Compute Node Power connector for Node 4
B	2x40 pin Bridge Board connector for Node 4
C	2x9 pin Power supply input connector
D	2x7 pin Power Control cable connector
E	2x9 pin Power supply input connector
F	2Blade Compute Node Power connector for Node 3
G	2x40 pin Bridge Board connector for Node 3
H	2x40 pin Bridge Board connector for Node 1
I	20-pin Front Panel cable connector for Node 1, 3
J	2Blade Compute Node Power connector for Node 1
K	2x9 pin Power supply input connector
L	2x9 pin Power supply input connector

M	2x40 pin Bridge Board connector for Node 2
N	2Blade Compute Node Power connector for Node 2
O	20-pin Front Panel cable connector for Node 2, 4

Figure 17. 16 x 2.5-inch Hard Drive Backplane Components (Rear View)

Advanced Management Options

Intel® Remote Management Module 4 Lite

The Intel® Remote Management Module 4 Lite plugs into a dedicated connector on the server board and provides additional server management functionality to the Compute Node.

This module, together with dedicated management port on IOM carrier sitting on Slot2 riser provides a dedicated web server for viewing server information and remote control of the system. It also provides Remote KVM Redirection and USB Media Redirection allowing USB devices attached to the remote system to be used on the managed server.

For instructions on installing the Intel® Remote Management Module 4 Lite, see [Installing and Removing the Intel® Remote Management Module 4 Lite](#).

2 Hardware Installations and Upgrades

Before You Begin

Before working with your server product, pay close attention to the Safety Information at the beginning of this manual.

Note: Whenever you service the system, you must first power down the server and unplug all peripheral devices and the AC power cord.

Tools and Supplies Needed

- Phillips* (cross head) screwdriver (#1 bit and #2 bit)
- Needle nosed pliers
- Anti-static wrist strap and conductive foam pad (recommended)

System Reference

All references to left, right, front, top, and bottom assume the reader is facing the front of the chassis as it would be positioned for normal operation.

Note: The Intel® Server System H2000JF is shown for illustration purpose. Server components with the product family are identical.

Cable Routing

The Intel® Server System H2000JF family is a high density system, containing four identical Compute Nodes inside. There are a few cables for chassis internal routing. Each Compute Node is installed in tray and can be hot swapped without any impact to other nodes.

When you add or remove components from Compute Node tray, make sure your cables are routed correctly before plug in the node tray back to chassis. Use caution to make sure no cables or wires are pinched and that the airflow from the fans is not blocked. Use the figures below to determine the correct cable routing.

For cable connection inside Node tray:

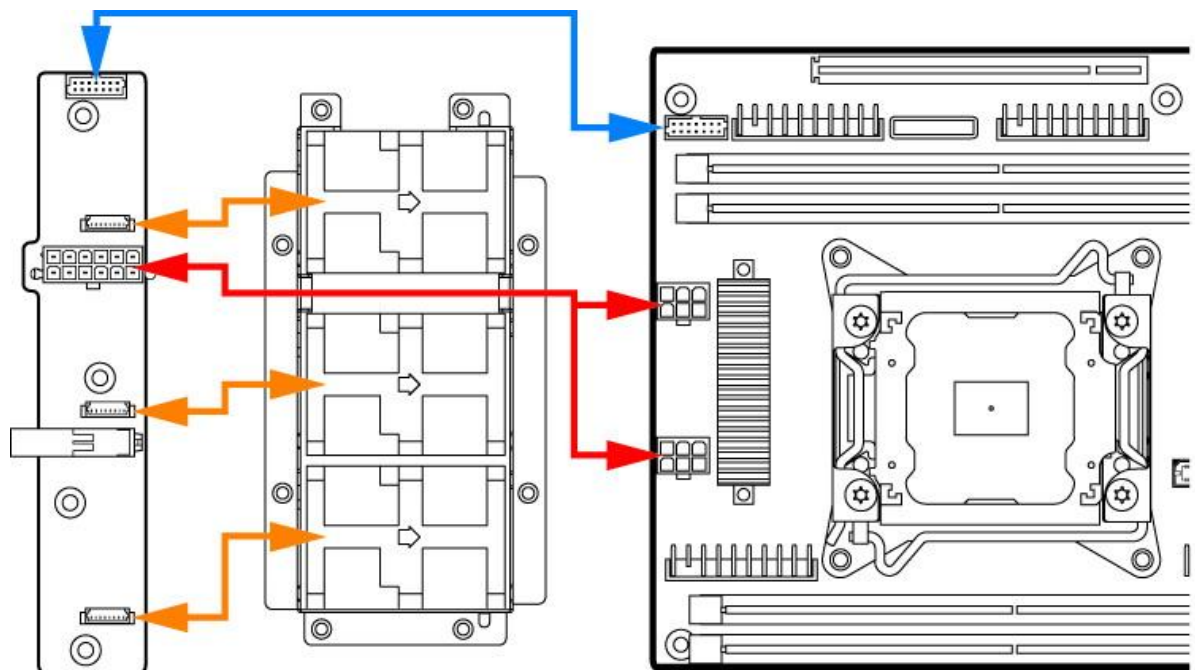

AF004464

Yellow Lines: Fan cable connection
Red Line: Mother board power cable connection
Blue line: Fan control signal cable connection

Figure 18. Cable Routing inside Node tray

Removing and Installing the Front Bezel

Removing the Front Bezel

If your system includes a front bezel, follow these steps to remove the front bezel:

1. Unlock the bezel if it is locked.

2. Remove the left end of front bezel from rack handle (see letter **A**).
3. Rotate the front bezel anticlockwise to release the latches on the right end from the rack handle (see letter **B**).

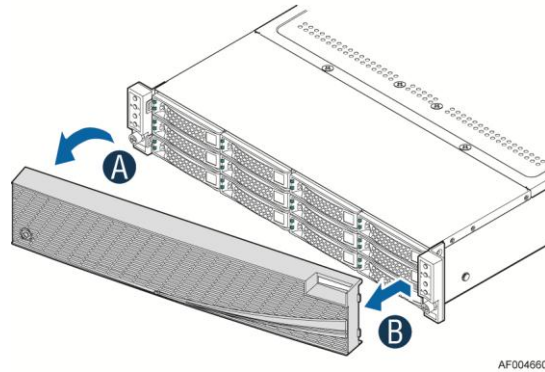

Figure 19. Removing the Front Bezel

Installing the Front Bezel

Note: Before installing the bezel, you must install the rack handles.

1. Lock the right end of the front bezel to the rack handle (see letter **A**).
2. Rotate the front bezel clockwise till the left end clicks into place (see letter **B**).
3. Lock the bezel if needed.

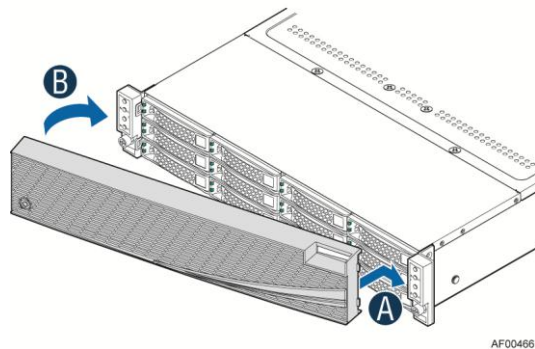

Figure 20. Installing the Front Bezel

Removing and Installing the System Top Cover

Removing the System Top Cover

The server system must be operated with the system cover in place to ensure proper cooling. You will need to remove the top cover to add or replace components (backplane, main power cables, power distribution board) inside of the server. Before removing the top cover, power down the server and unplug all peripheral devices and the power cable(s).

Note: A non-skid surface or a stop behind the server system may be needed to prevent the server system from sliding on your work surface.

1. Observe the safety and ESD precautions at the beginning of this book.
2. Turn off all peripheral devices connected to the server. Turn off the server.
3. Disconnect the power cord.
4. Remove the screws (see letter **A**).
5. Lift the top cover from front end to more than 45 degrees (see letter **B**).
6. Remove the top cover.

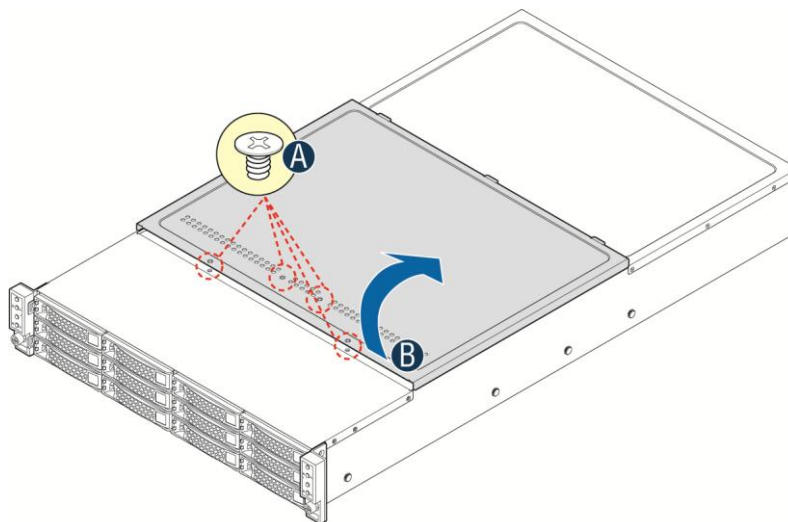

AF004902

Figure 21. Removing the System Top Cover

Installing the System Cover

1. Place system cover onto the chassis and slide forward to engage recessed edge at front of cover (see letter **A**).
2. Rotate the front end of top cover down to position and fix and screws (see letter **B**).

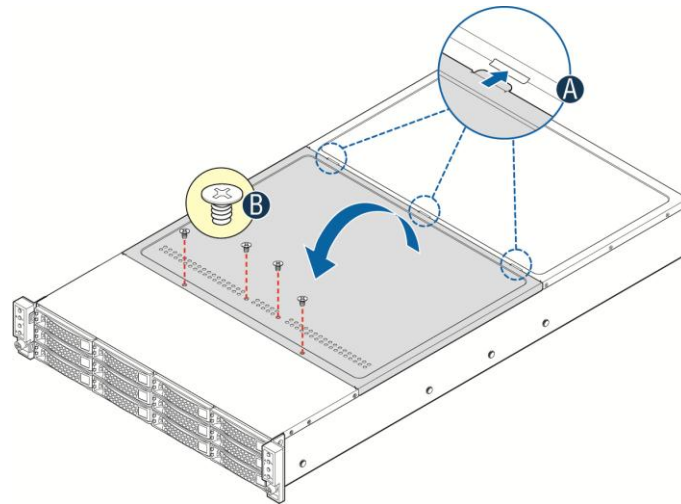

AF005080

Figure 22. Installing the System Cover

Removing and Installing the Compute Node Tray

Each Compute Node tray is identical in the chassis. They are designed for either “cold” or “hot” swappable. The Noe Tray can only be plugged from rear chassis.

Removing the Node Tray

1. Carefully push the latch in, on the left hand side of the Node Tray.
2. Pull the handle with the Node Tray while still pressing the latch.

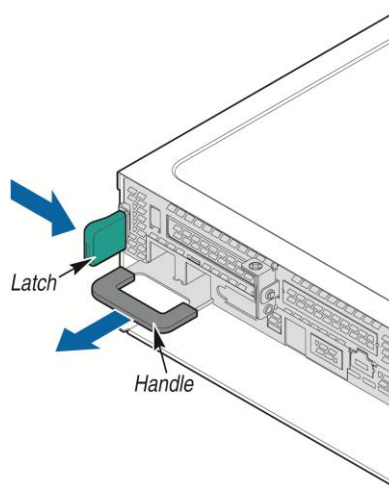

AF004245

Figure 23. Pulling out the Node Tray

Installing the Node Tray

1. Align and slide in the Node Tray to the chassis rail.
2. Push the Node Tray along the rail until the latch locks in position with a “tick”.

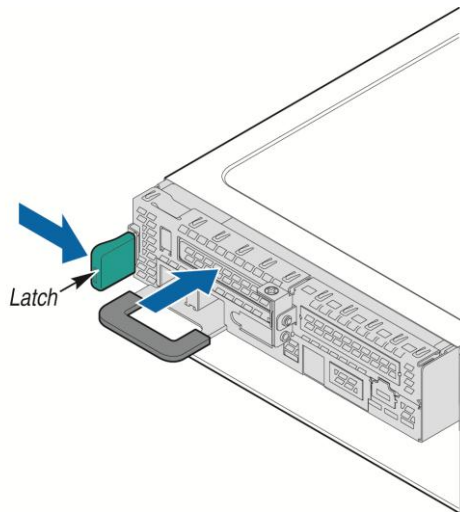

AF004246

Figure 24. Installing the Node Tray

Removing and Installing the Redundant Power Supply Unit

The system equipped with two CRPS for redundancy. Each of them can be hot swappable.

Removing the Power Supply Unit

1. Carefully push in the latch on the right hand of PSU.
2. Pull the handle with the PSU while still press the latch.

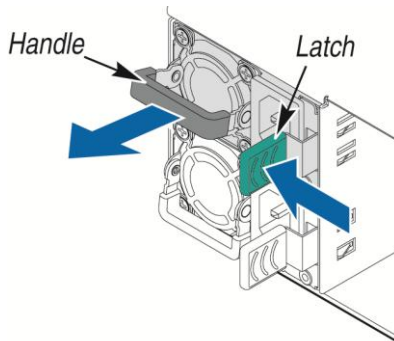

AF004247

Figure 25. Removing the PSU

Installing the Power Supply Unit

1. Align and slide in the PSU to the power cage rail.
2. Push the PSU along the rail until the latch locks in position with a “tick”.

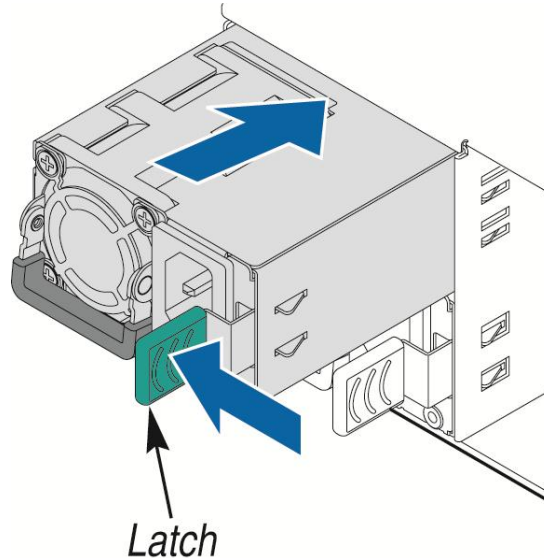

AF004248

Figure 26. Installing the PSU

Removing and Installing the Node Tray Air Duct

Always operate your server system with the air duct in place. The air duct is required for proper airflow within the server system.

Removing the Air Duct

1. Press and hold both left and right side of rear air duct (see letter **A**).
2. Slowly lift the rear end of air duct (see letter **B**).
3. When rotate airduct to more than 45 degrees, pull out the air duct.

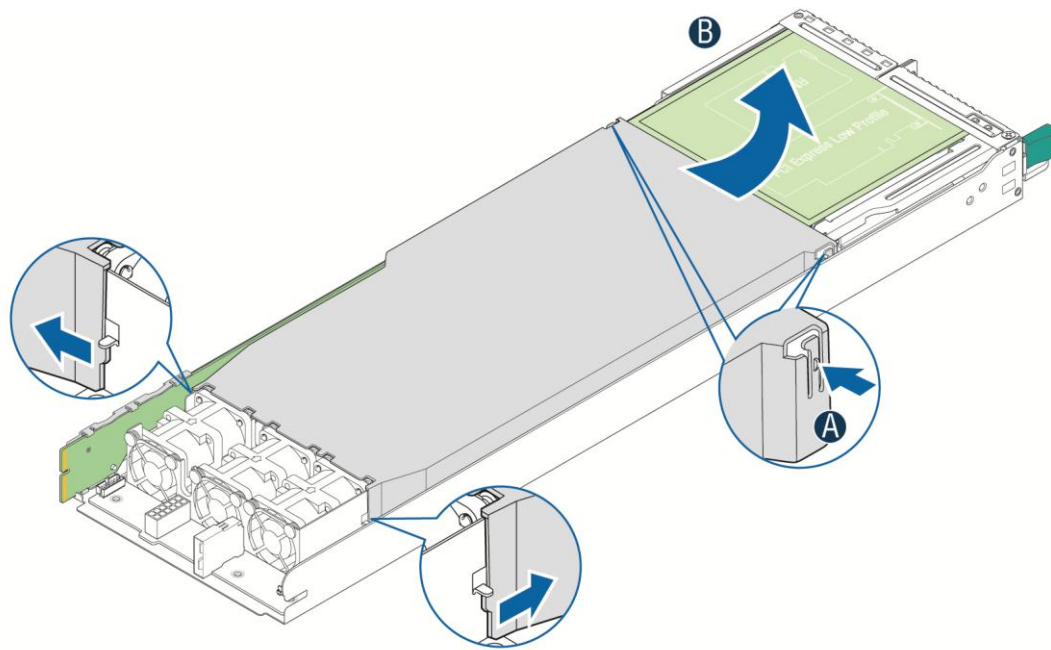

AF005092

Figure 27. Removing the Air Duct

Installing the Air Duct

1. Align the front end of air duct to chassis fixture (see letter **A**).
2. Low down rear end of air duct to fixture with a “tick” (see letter **B**).

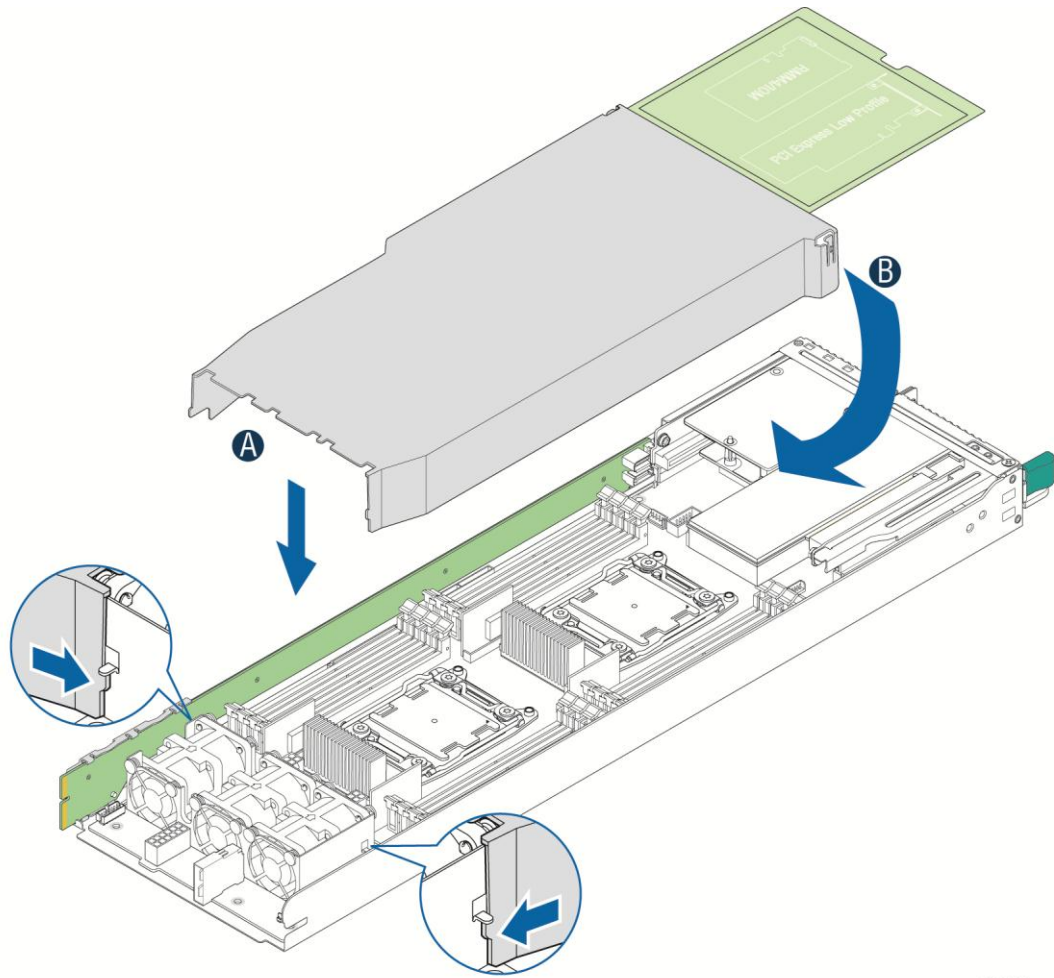

AF005093

Figure 28. Installing the Air Duct

Transparent Mylar Installation

In case IOM carrier on slot2 or PCIe add-in card on riser slot 1 is installed, the transparent Mylar attached to the air duct must be installed in between add-in card and rear IO bracket for isolation.

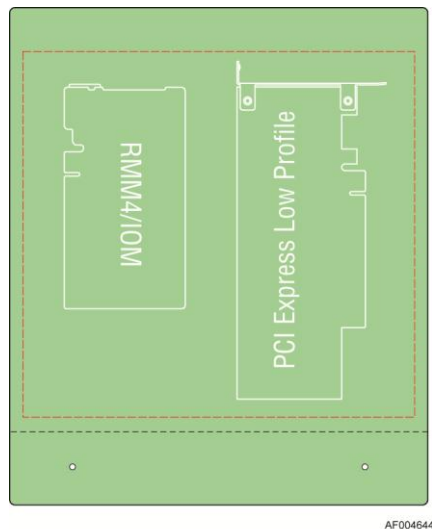

Figure 29. Transparent isolation film for air duct

Removing and Installing Processor

The heatsink has thermal interface material (TIM) on the underside of it. Use caution so that you do not damage the thermal interface material. Use gloves to avoid sharp edges.

Removing Processor Heatsink(s)

The heatsink is attached to the server board/processor socket with captive fasteners. Using a #2 Phillips* screwdriver, loosen the four screws located on the heatsink corners in a diagonal manner using the following procedure:

1. Using a #2 Phillips* screwdriver, start with screw 1 and loosen it by giving it two rotations and stop (see letter **A**). (IMPORTANT: Do not fully loosen.)
2. Proceed to screw 2 and loosen it by giving it two rotations and stop (see letter **B**). Similarly, loosen screws 3 and 4. Repeat steps A and B by giving each screw two rotations each time until all screws are loosened.
3. Lift the heatsink straight up (see letter **C**).

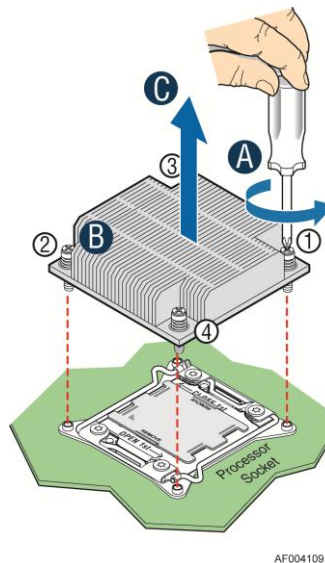

Figure 30. Removing Processor Heatsink

Installing the Processor

Caution: Processor must be appropriate: You may damage the server board if you install a processor that is inappropriate for your server. For a web link to the list of compatible processor(s), see “Additional Information and Software” on page vi.

Caution: ESD and handling processors: Reduce the risk of electrostatic discharge (ESD) damage to the processor by doing the following:

1. Touch the metal chassis before touching the processor or server board. Keep part of your body in contact with the metal chassis to dissipate the static charge while handling the processor.
2. Avoid moving around unnecessarily.

Caution: Protective socket cover needs to be removed for proper cooling of the processor; failure to remove the cover could result in damage to the system.

1. Open the Socket Lever. Push down the lever handle on the **OPEN 1st** side and away from the socket to release it (see letter **A**). Repeat the steps to release the lever on the other side (see letter **B**).

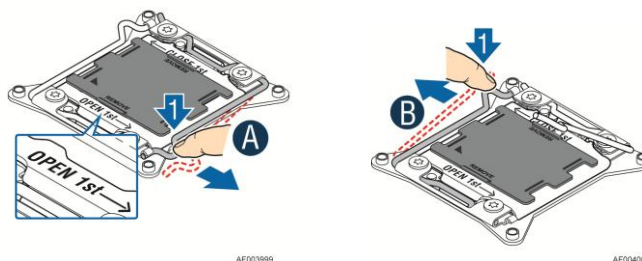

Figure 31. Installing Processor – Open the Socket Lever

2. Open the Load Plate. Press the locking lever slightly to raise the load plate (see letter **A**). Open the load plate all the way (see letter **B**).

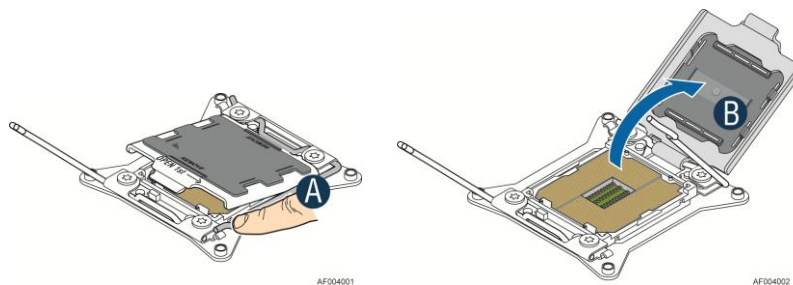

Figure 32. Installing Processor – Open the Load Plate

3. Install the Processor. Take the processor out of the box and remove the protective shipping cover (see letter **A**). Orient the processor with the socket so that the processor cutouts match the four orientation posts on the socket (see letter **B**). Note location of gold key at corner of processor (see letter **C**).

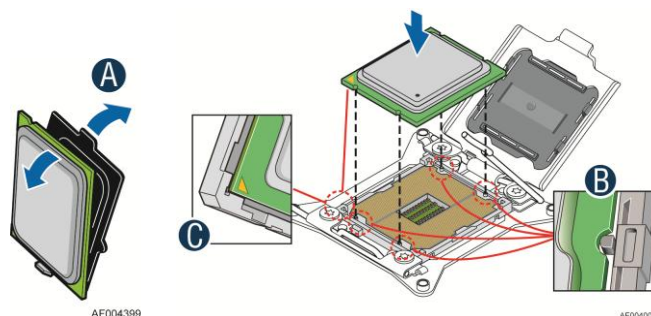

Figure 33. Installing Processor – Install the Processor

Note: The underside of the processor has components that may damage the socket pins if installed improperly. Processor must align correctly with the socket opening before installation. **DO NOT DROP processor into the socket!**

4. Remove the Cover. Press the cover to remove it. Save the protective cover.

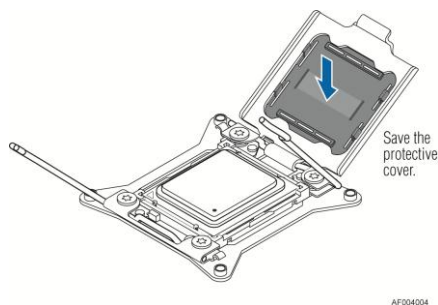

Figure 34. Installing Processor – Remove the Cover

5. Close the Load Plate. Carefully lower the load plate over the processor.

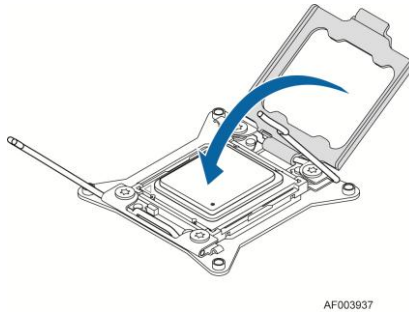

Figure 35. Installing Processor – Close the Load Plate

6. Latch the Locking Lever. Push down on the locking lever on the CLOSE 1st side (see letter **A**). Slide the tip of the lever under the notch in the load plate (see letter **B**). Make sure the load plate tab engages under the socket lever when fully closed. Repeat the steps to latch the locking lever on the other side (see letter **C**). Latch the levers in the order as shown.

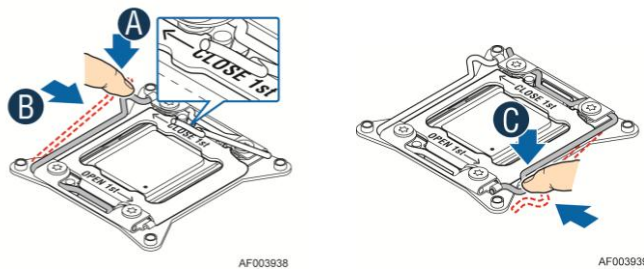

Figure 36. Installing Processor – Latch the Locking Lever

Installing Processor Heatsink(s)

*Note: The processor heatsink for CPU1 and CPU2 is different. **FXXCA91X91HS** (IPN: **E89205**) is for CPU1, while **FXXEA91X91HS** (IPN: **G19642**) is for CPU2. Mis-locating the heatsink will cause serious thermal damage!*

1. Remove the protective film on the TIM if present (see letter **A**).
2. Align heatsink fins to the front and back of the chassis for correct airflow. Airflow goes from front-to-back of chassis (see letter **B**).

Each heatsink has four captive fasteners and should be tightened in a diagonal manner using the following procedure:

3. Using a #2 Phillips* screwdriver, start with screw 1 and engage screw threads by giving it two rotations and stop (see letter **C**). (Do not fully tighten.)
4. Proceed to screw 2 and engage screw threads by giving it two rotations and stop (see letter **D**). Similarly, engage screws 3 and 4.
5. Repeat steps C and D by giving each screw two rotations each time until each screw is lightly tightened up to a maximum of 8 inch-lbs torque (see letter **E**).

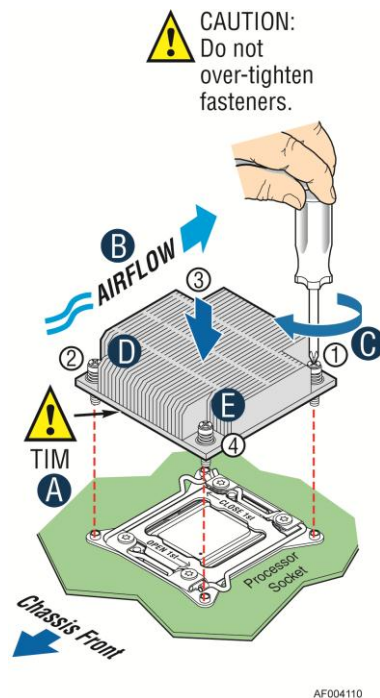

Figure 37. Installing Processor Heatsink

Removing the Processor

1. Remove the processor heatsink, see Figure 30.
2. Open the socket lever, see Figure 31.
3. Open the load plate, see Figure 32.
4. Remove the processor.

Installing and Removing Memory

Installing Memory

1. Locate the DIMM sockets. Make sure the clips at either end of the DIMM socket(s) are pushed outward to the open position (see letter **A**).
2. Holding the DIMM by the edges, remove it from its anti-static package. Position the DIMM above the socket. Align the notch on the bottom edge of the DIMM with the key in the DIMM socket (see letter **B**).
3. Insert the bottom edge of the DIMM into the socket (see letter **C**). When the DIMM is inserted, push down on the top edge of the DIMM until the retaining clips snap into place (see letter **D**). Make sure the clips are firmly in place (see letter **E**).

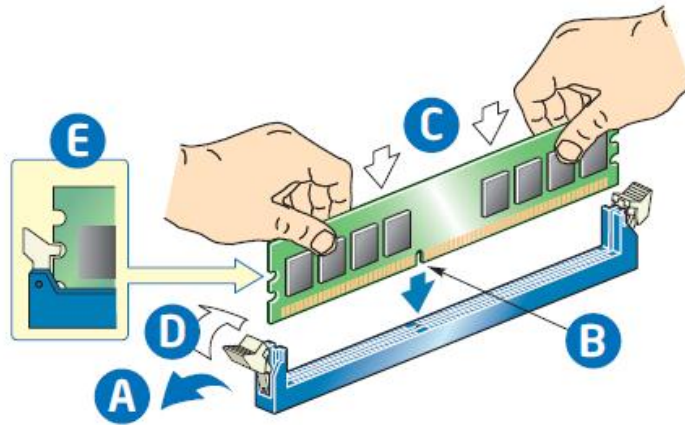

Figure 38. Installing Memory

Removing Memory

1. Locate the DIMM sockets. Gently spread the retaining clips at each end of the socket. The DIMM lifts from the socket.
2. Holding the DIMM by the edges, lift it from the socket, and store it in an anti-static package.

Installing and Removing Hot-swap Hard Drive

Caution: If you don't install all drives, empty drive bays must be occupied by carriers with plastic drive blank provided to maintain proper system cooling.

Installing a Hard Disk Drive into 3.5" Hard Drive Carrier

1. Remove the four screws securing the HDD interface bracket and install 3.5" HDD with screws shown in letter **A**.

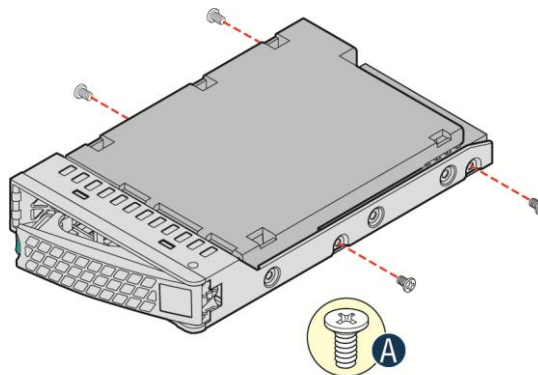

AF004461

Figure 39. Installing Hard Disk Drive – installing 3.5" HDD to carrier

2. With the lever open, insert the hard disk drive assembly into the chassis (see letter **A**). Push in the lever to lock it into place (see letter **B**).

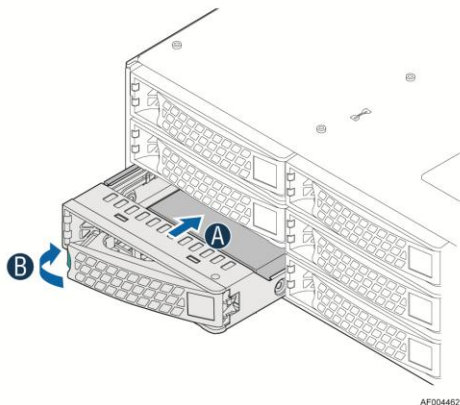

Figure 40. Installing Hard Disk Drive – Inserting 3.5” HDD assembly

Installing a Hard Disk Drive into 2.5” Hard Drive Carrier

1. Remove the four screws securing the plastic drive blank from the 2.5" HDD carrier and install the 2.5" HDD with screws shown in below drawing.

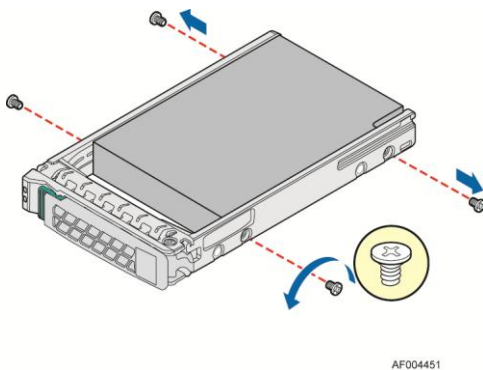

Figure 41. Installing Hard Disk Drive – Installing 2.5” HDD to carrier

2. With the lever open, insert the hard disk drive assembly into the chassis, then push in the lever to lock it into place (see letter **F**).

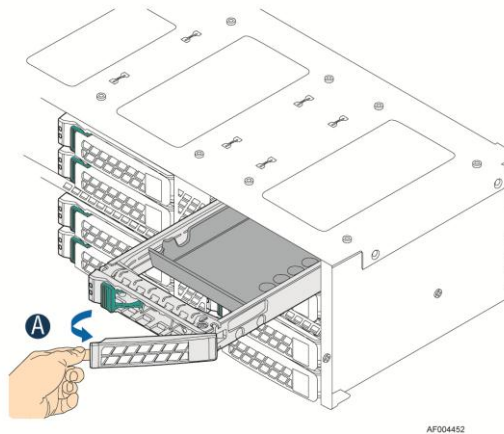

Figure 42. Installing Hard Disk Drive – Inserting 2.5” HDD assembly

Installing and Removing the PCIe Riser Assembly

On Riser Slot 1

Installing the PCI Riser Assembly and add-in card

1. Install the riser to bracket by fastening screws in in letter **A**.

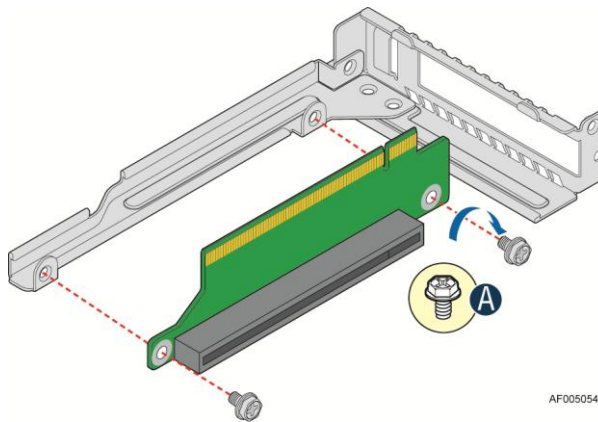

Figure 43. Assembly riser with bracket

2. Plug in the PCIe add-in card to slot on riser (letter **C**) and fix the card bracket to assembly rear panel (letter **B**).

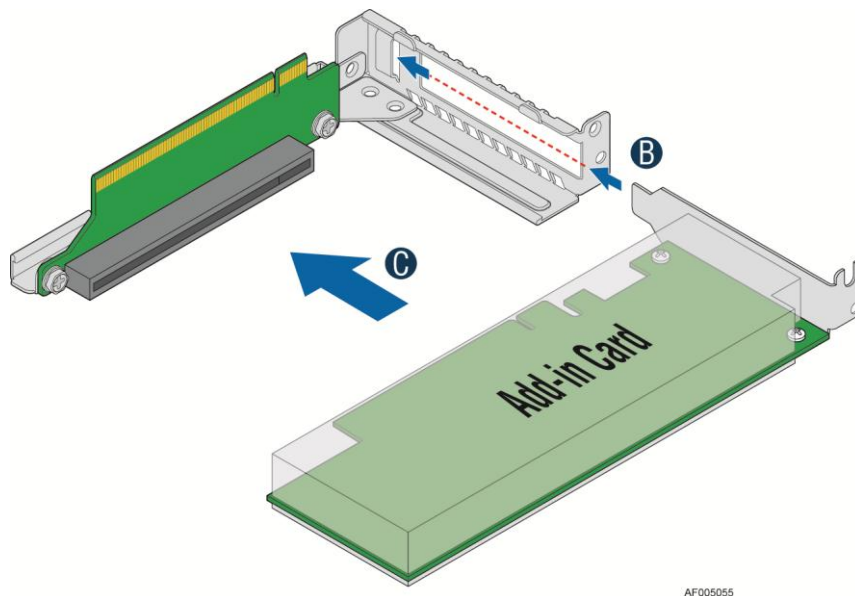

Figure 44. Plug in PCIe add-in card

3. Plug in the assembly to riser slot on baseboard (see letter **D**) and fasten the screw (letter **E**).

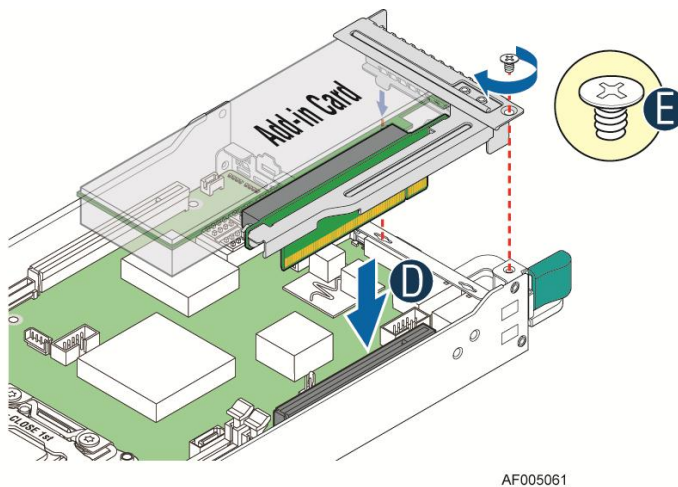

Figure 45. Installing PCI Riser Assembly

Removing a PCI Add-in Card

You must remove the IOM carrier assembly together with PCIe add-in card riser assembly.

1. Remove IOM carrier assembly (letter **A**) by loosening the screws (letter **B** and **C**).

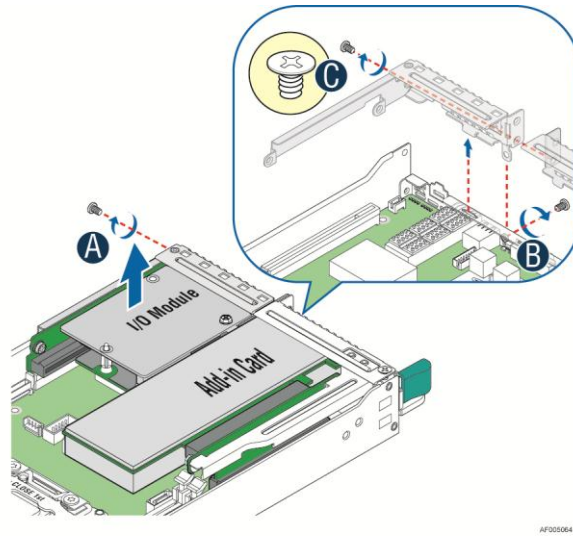

Figure 46. Removing IOM assembly

2. Remove PCIe riser assembly (letter **B**) by loosening the screw (letter **A**).

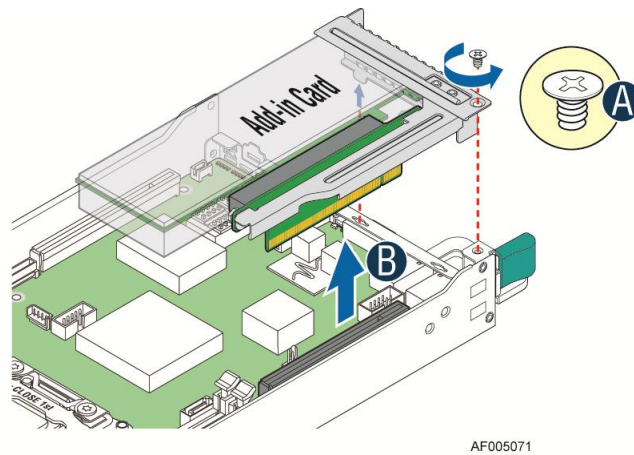
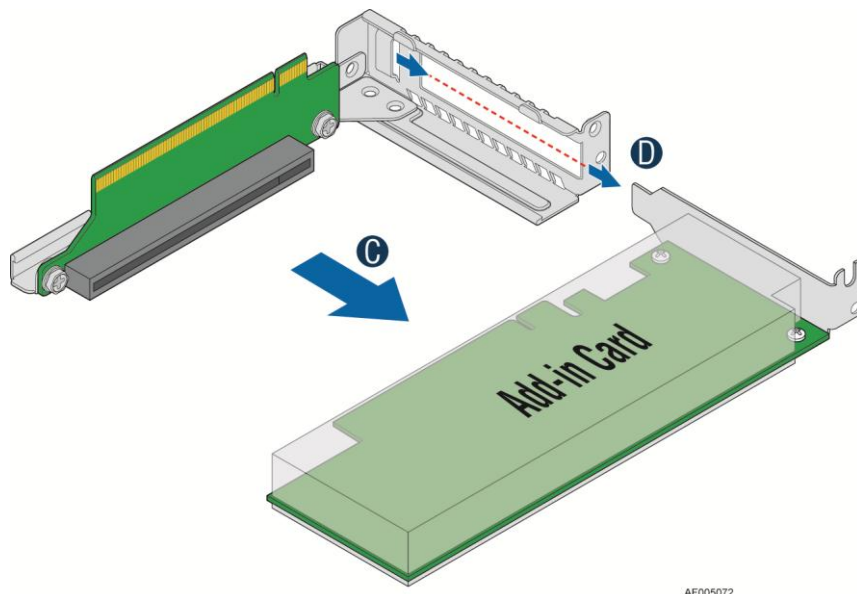

Figure 47. Removing PCIe add-in card assembly

3. Remove PCIe add-in card from slot (letter **C**) and bracket (letter **D**).



AF005072

Figure 48. Removing PCIe add-in card from riser slot

Note: Make sure that all empty add-in card slots have filler panels installed.

On Riser Slot 2

Installing IOM riser and carrier assembly

The IOM riser and carrier assembly are provided as optional accessory. This assembly provides the support to Intel® RMM4 dedicated NIC port and IO module.

1. Install IO module to IOM carrier using screw in letter **B**.

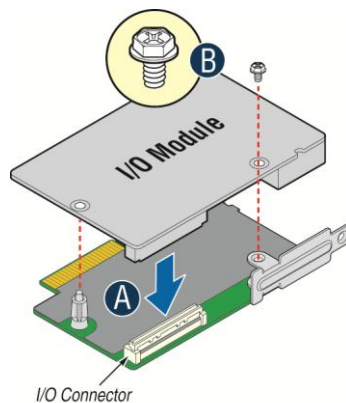

AF004625

Figure 49. Install IO module

2. Install rear bracket (letter **D**) and plug in the whole assembly to IOM riser slot indicated by letter **C**.

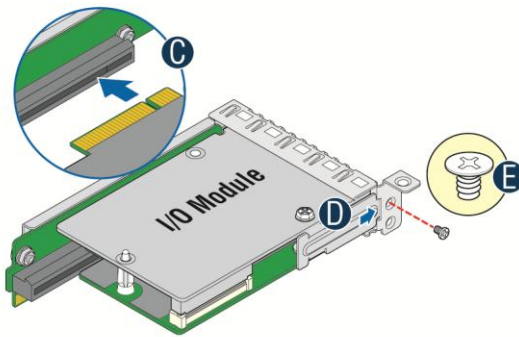

AF004626

Figure 50. Installing assembly to riser

3. Plug in the whole IOM assembly into riser slot 2 on baseboard (letter **F**) and fasten with screws (letter **G** and **E**).

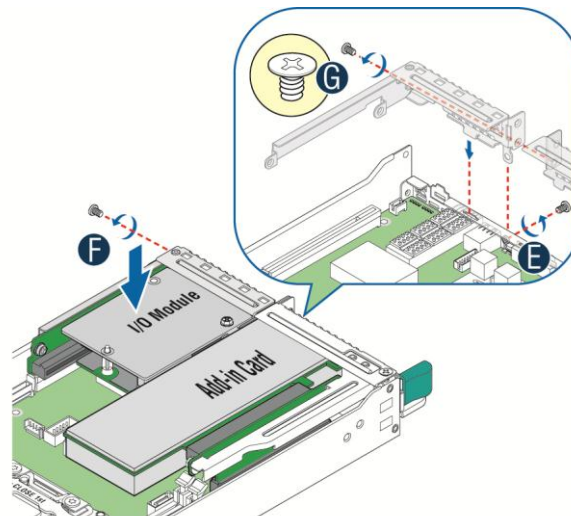

AF005063

Figure 51. Fastening the assembly in chassis

Removing IO module

1. Loosen assembly screws (letter **B** and **C**) and plug out IOM assembly (letter **A**).

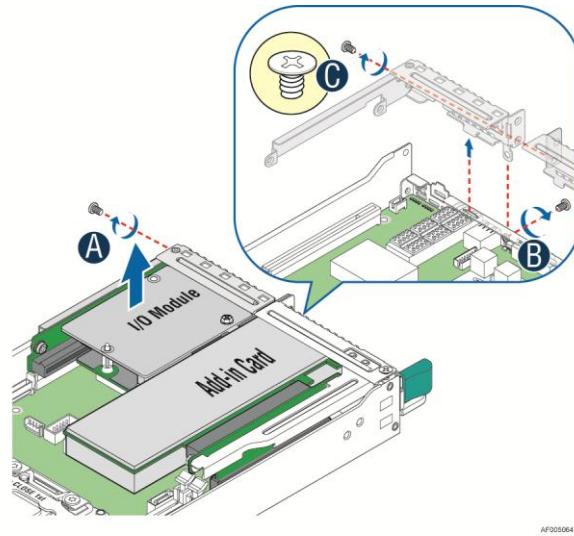
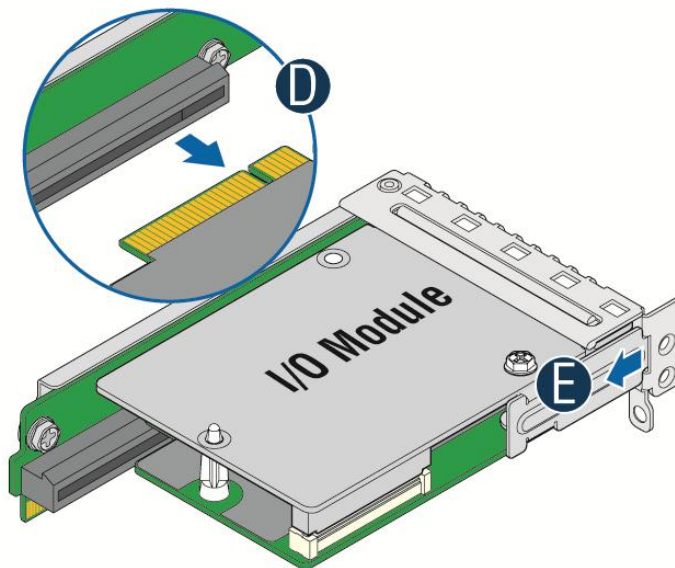

Figure 52. Remove IOM assembly

2. Remove IO module and carrier assembly from riser slot (letter **D**) and remove rear bracket (letter **E**).



AF005065

Figure 53. Removing IOM assembly from chassis

3. Release screw in letter **G**, and remove IO module from assembly (letter **F**).

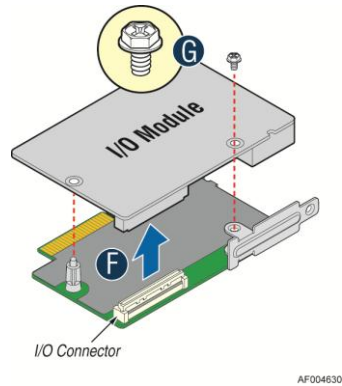

Figure 54. Removing IO module from assembly

Installing and Removing the Intel® Remote Management Module 4 Lite

Installing the Intel® RMM4 Lite

Locate the RMM4 Lite connector next to RISER SLOT_2. Carefully pickup the Intel® RMM4 Lite module. Match the alignment pin of the module and the connector on the server board, and press to install.

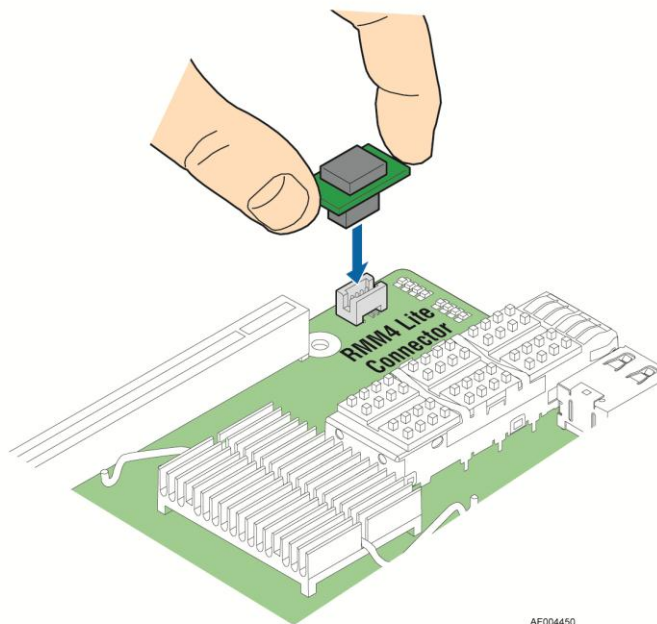

Figure 55. Installing the Intel® RMM4 Lite

Installing the Intel® Storage Upgrade Key

Installing the Intel® Storage Upgrade Key

The server board supports various Intel® Storage Upgrade Keys for different storage configuration. Below is the list of supported Storage Upgrade Key.

Table 5. POST Progress Code LED Example

Intel® RAID C600 Upgrade Key Options (Intel Product Codes)	Key Color	Description
Default – No option key installed	N/A	4 Port SATA with Intel® ESRT RAID 0,1,10 and Intel® RSTe RAID 0,1,5,10
RKSATA4R5	Black	4 Port SATA with Intel® ESRT2 RAID 0,1, 5, 10 and Intel® RSTe RAID 0,1,5,10
RKSAS4	Green	4 Port SAS with Intel® ESRT2 RAID 0,1, 10 and Intel® RSTe RAID 0,1,10
RKSAS4R5	Yellow	4 Port SAS with Intel® ESRT2 RAID 0,1, 5, 10 and Intel® RSTe RAID 0,1,10

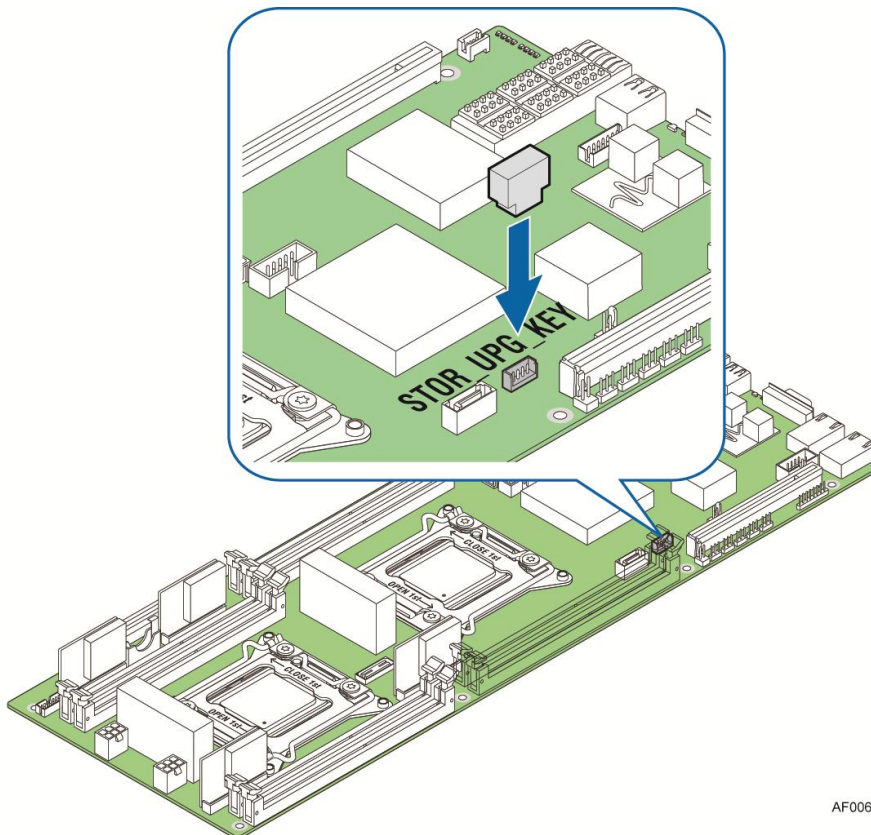

AF00679

Figure 56. Installing the Intel® Storage Upgrade Key

Installing and Removing the Bridge Board

Removing the Bridge Board

1. Release the fixing screws (letter **A**) on the bridge board.
2. Straightly lift up bridge board to remove from the server board.

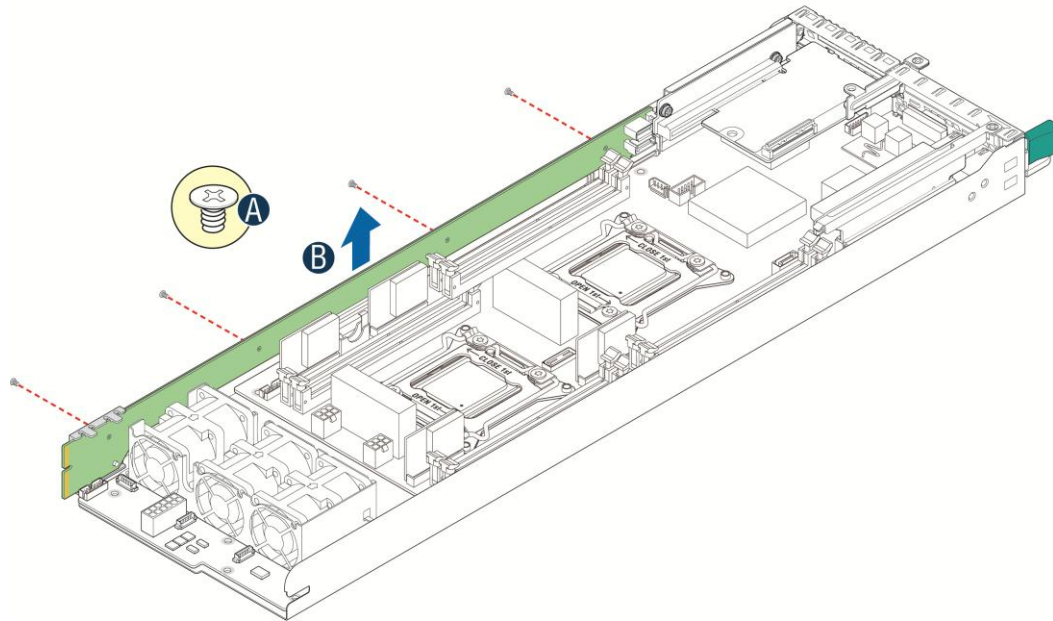

AF004313

Figure 57. Removing the bridge board

Installing the Bridge Board

1. Attach the plastic holder to the front end of bridge board (letter **A**).
2. Plug the rear end of bridge board to the slot on base board (letter **B**).
3. Secure the bridge board with four screws (see letter **C**) to the tray side wall.

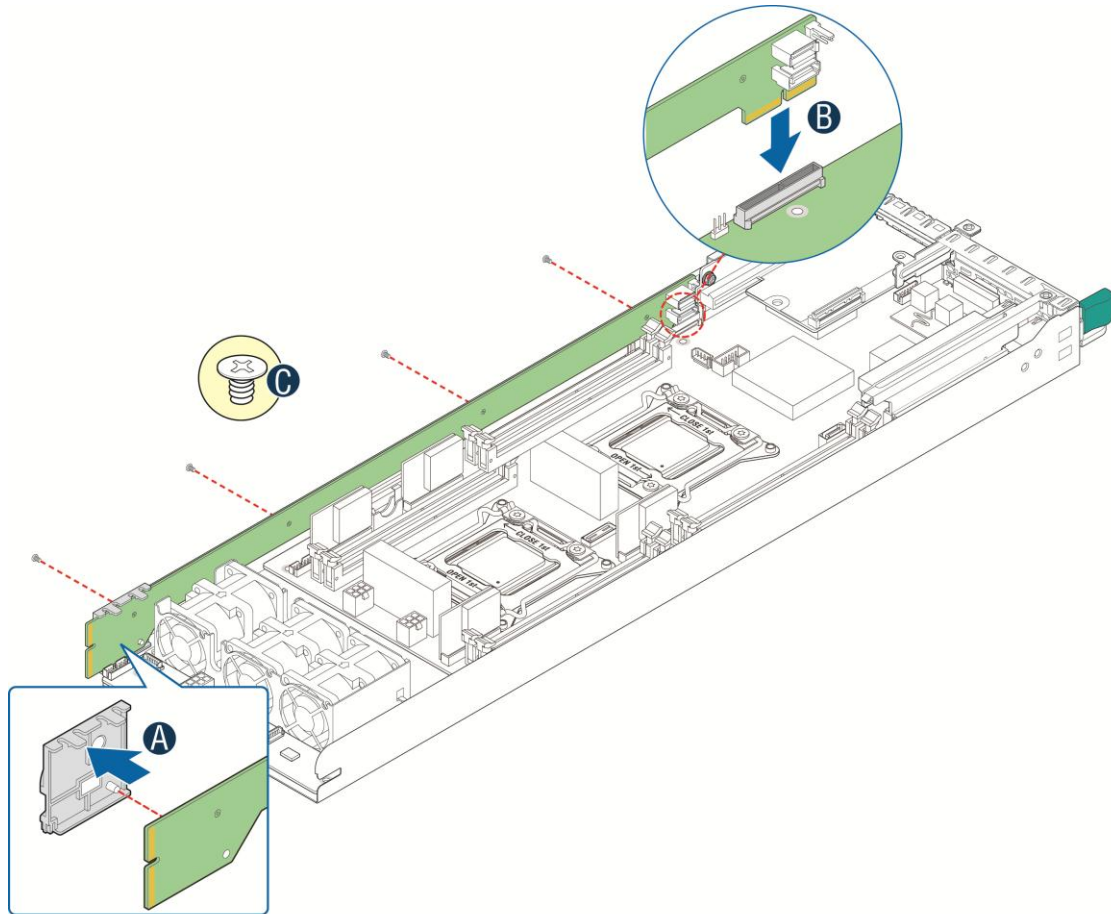

AF004312

Figure 58. Installing the Bridge Board

Installing and Removing the Node Power Docking Board

Removing the NPD Board

1. Disconnect all cables from the NPD board.
2. Remove the four screws to release the NPD board from tray base.
3. Straightly lift up the NPD board to remove from the tray base.

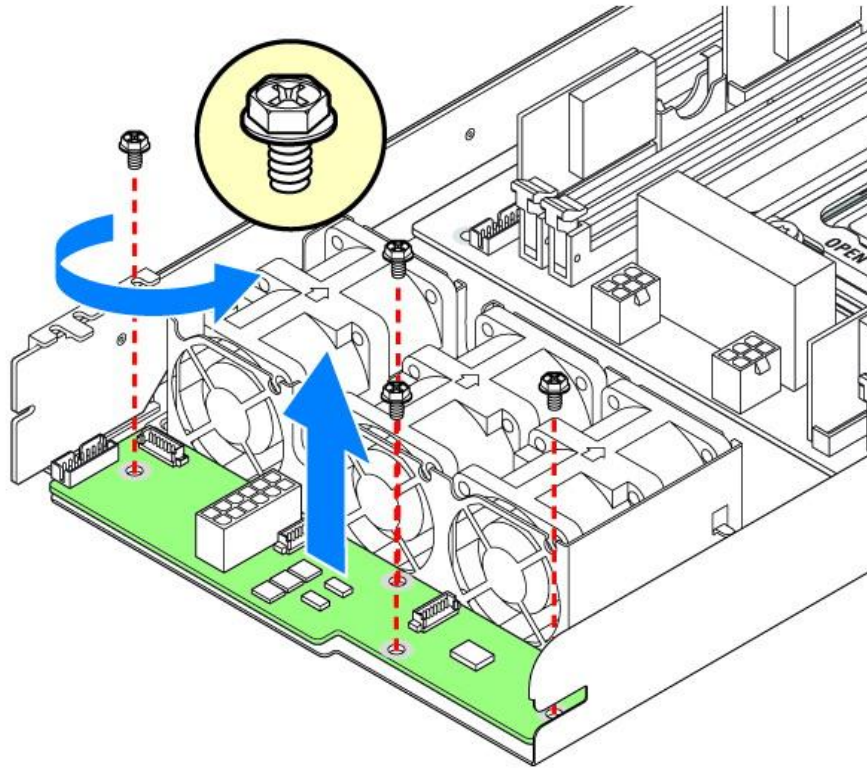

AF004689

Figure 59. Removing the NPD board

Installing the NPD Board

1. Place the NPD board into the tray base.
2. Secure the NPD board with four screws.
3. Connect all cables between NPD board and server board.

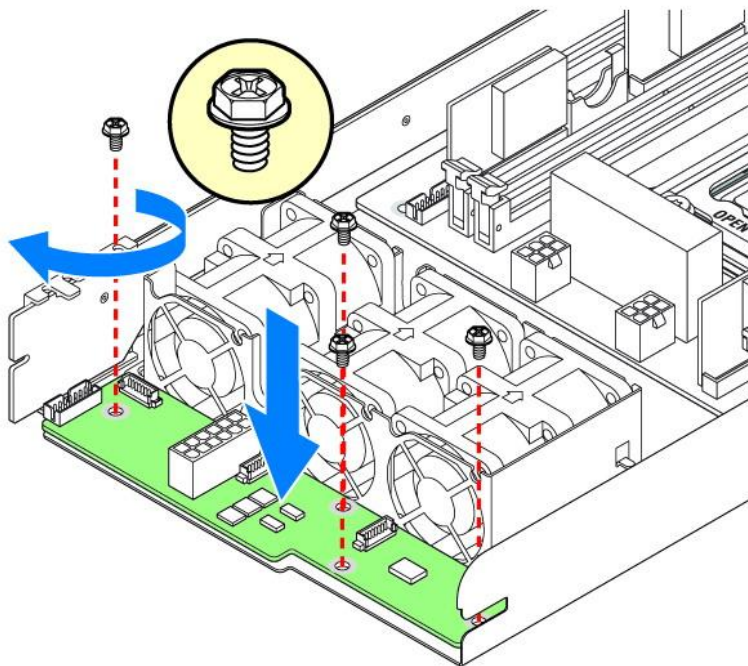

AF004690

Figure 60. Installing the NPD Board

Installing and Removing the Fan set in node tray

Removing the Fan set

1. Disconnect Fan cable from the NPD board.
2. Remove Fan set from dock.

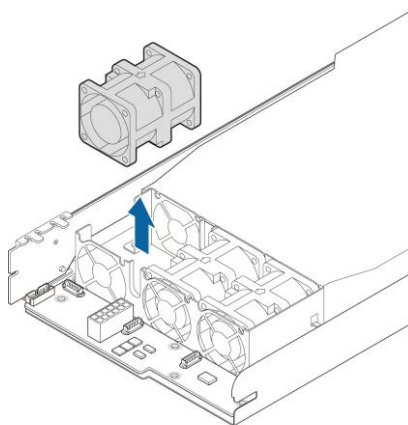

AF004325

Figure 61. Removing the Node Fan set

Installing the Fan set

1. Place the Fan set into dock.
2. Connect the Fan set cable to connector on NPD board.

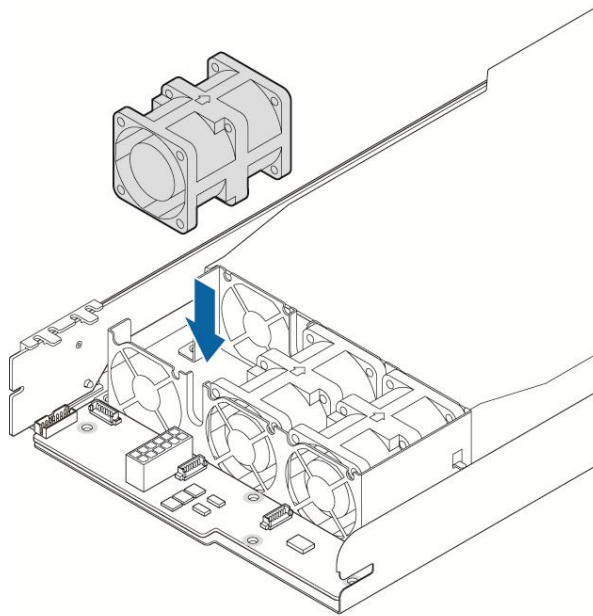

AF004693

Figure 62. Installing the Server Board

Installing and Removing the 2.5” Backplane Board

Removing the 2.5” Backplane board

1. Disconnect all cables from the backplane board.
2. Remove the four screws to release the backplane board from chassis.
3. Straightly lift up the backplane board to remove from the chassis holder.

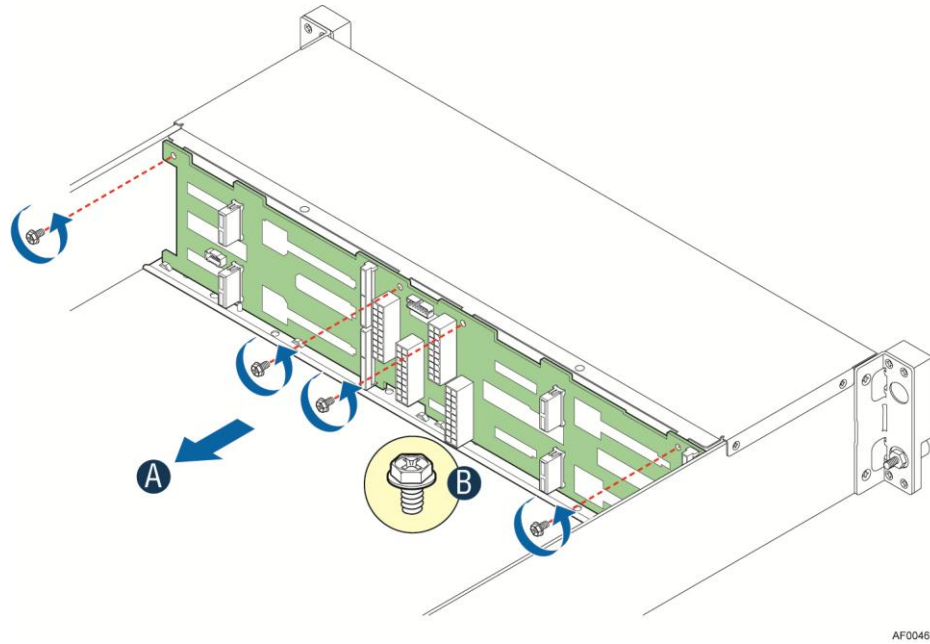

Figure 63. Removing the 2.5" backplane board

Installing the Server Board

1. Place the backplane board into the clamps on chassis base.

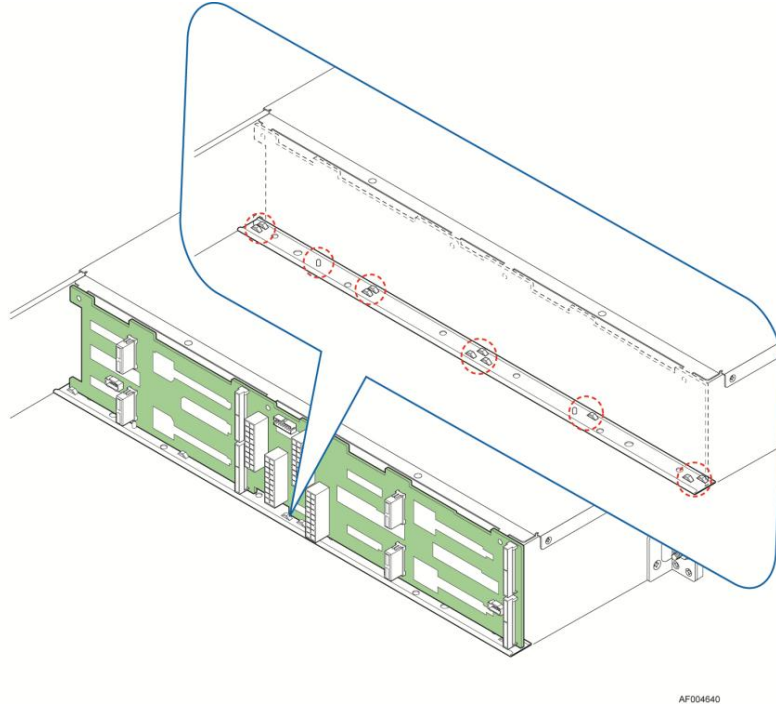

Figure 64. Align the backplane to the clamps on the chassis base

2. Secure the backplane board with four screws (see letter **B**).

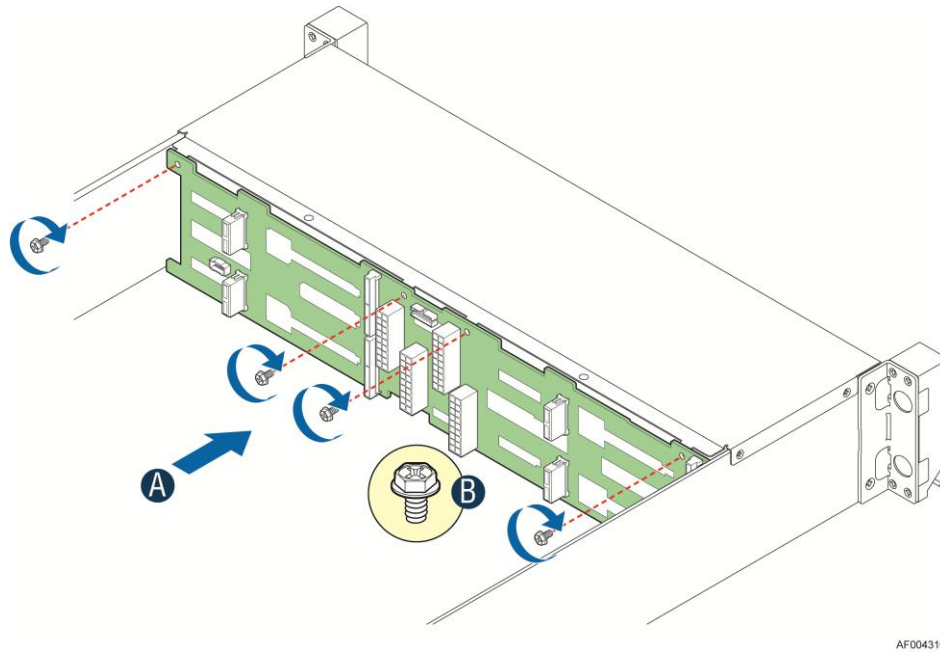

Figure 65. Installing the 2.5" backplane board

3. Reconnect all cables to the backplane.

Installing and Removing the 3.5" Backplane Board

Removing the 3.5" Backplane board

1. Disconnect all cables from the backplane board.
2. Remove the three screws to release the backplane board from chassis.
3. Straightly lift up the backplane board to remove from the chassis holder.

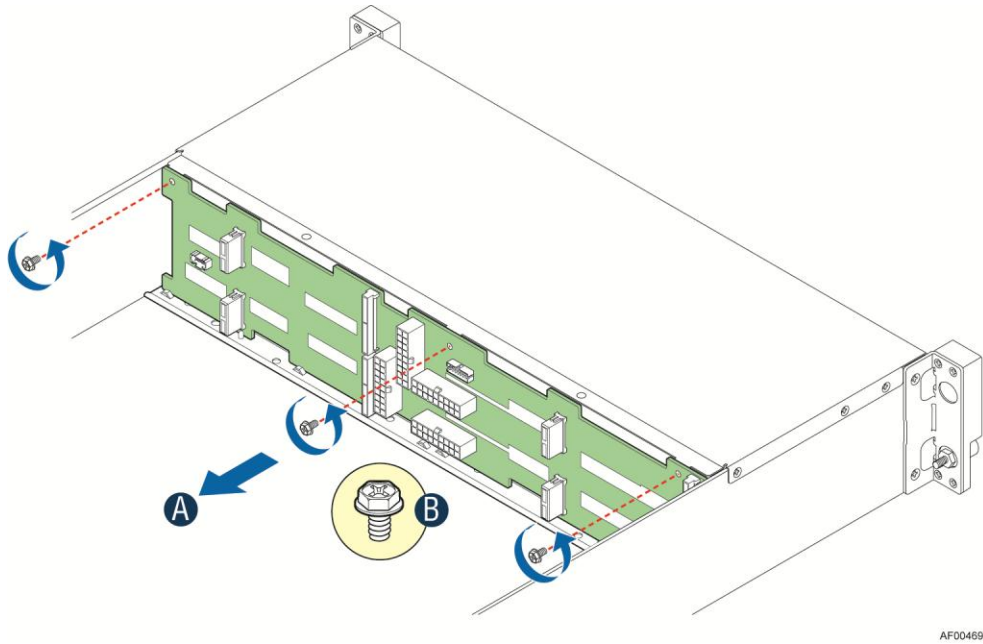

Figure 66. Removing the 2.5" backplane board

Installing the Server Board

1. Place the backplane board into the clamps on chassis base.

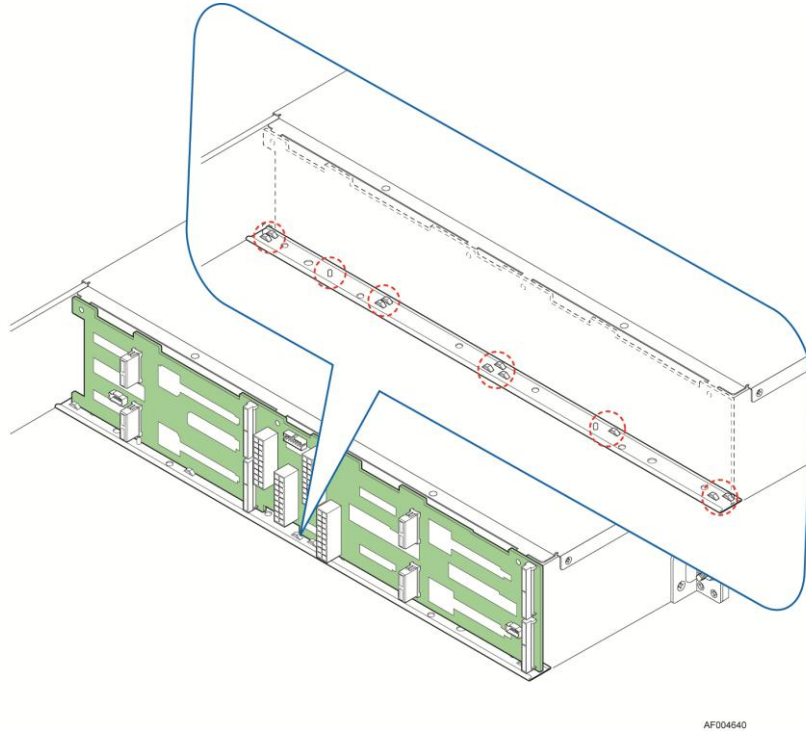

Figure 67. Align the backplane to the clamps on the chassis base

2. Secure the backplane board with three screws (see letter **B**).

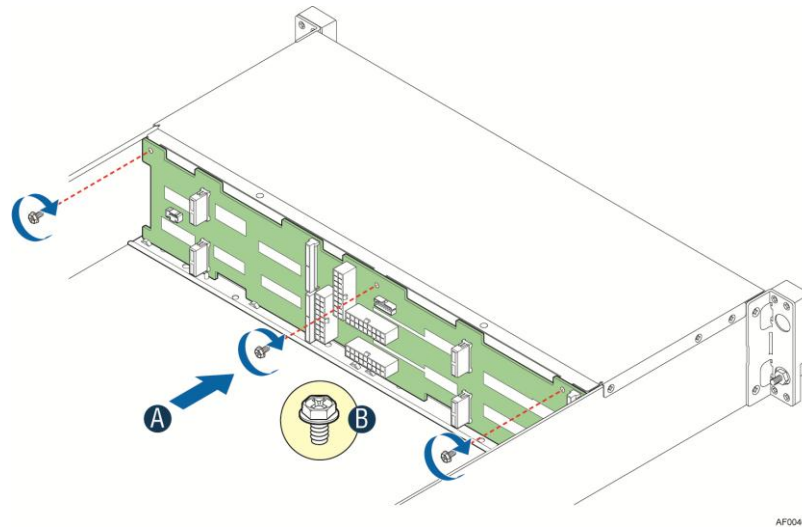

Figure 68. Installing the 2.5" backplane board

3. Reconnect all cables to the backplane.

Installing and Removing the Power Distribution Board

Removing the PDB

1. Remove top cover and power supply units from chassis.
2. Remove power cables and PMBus cable between PDB and backplane.
3. Release the four screws of upper PDB board and remove it.

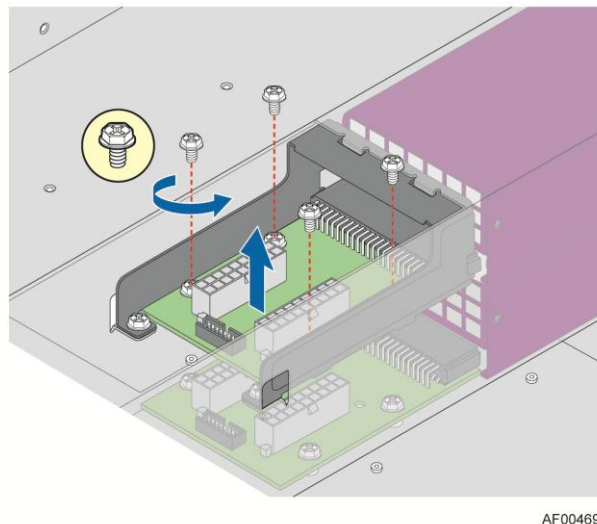
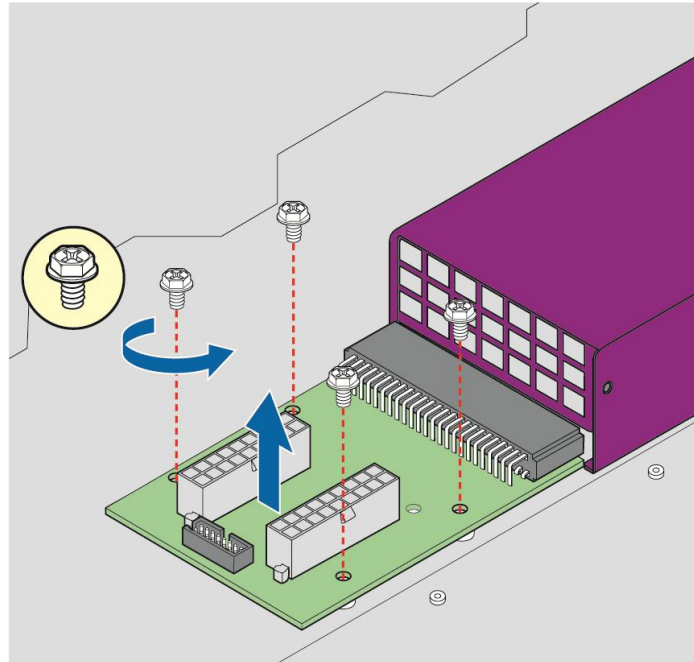

Figure 69. Removing the upper PDB

4. Release the four screws of lower PDB board and remove it.



AF004697

Figure 70. Removing the lower PDB

Installing the PDB

1. Remove top cover and power supply units from chassis.
2. Install the lower PDB first and secure with four screws.

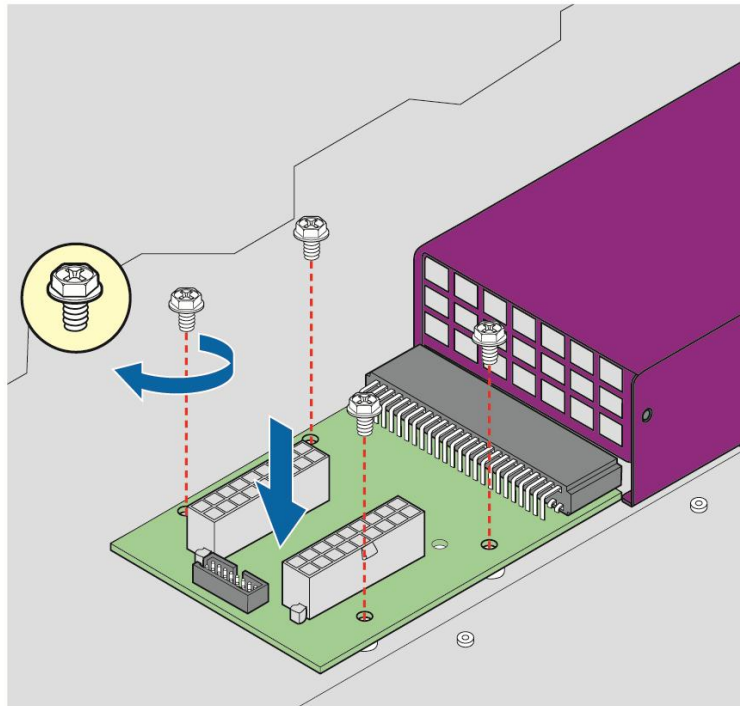

AF004694

Figure 71. Installing the lower PDB

3. Connect the power cables and PMBus cable to lower PDB.
4. Install the upper PDB and secure with four screws.

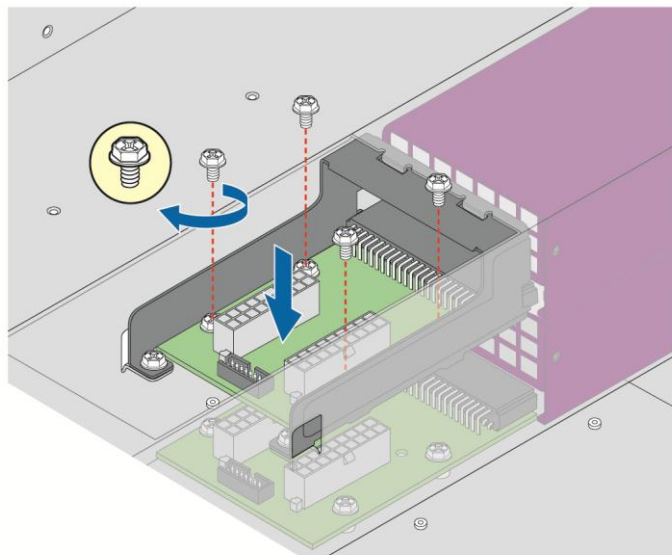

AF004695

Figure 72. Installing the upper PDB

5. Connect power cables and PMBus cable to upper PDB.
6. Close top cover and install power supply units.

Replacing the Backup Battery

The lithium battery on the server board powers the RTC for up to 10 years in the absence of power. When the battery starts to weaken, it loses voltage, and the server settings stored in CMOS RAM in the RTC (for example, the date and time) may be wrong. Contact your customer service representative or dealer for a list of approved devices.

Warning: *Danger of explosion if battery is incorrectly replaced. Replace only with the same or equivalent type recommended by the equipment manufacturer. Discard used batteries according to manufacturer's instructions.*

Advarsel: Lithiumbatteri - Eksplosionsfare ved fejlagtig håndtering. Udskiftning må kun ske med batteri af samme fabrikat og type. Levér det brugte batteri tilbage til leverandøren.

Advarsel: Lithiumbatteri - Eksplosjonsfare. Ved utskifting benyttes kun batteri som anbefalt av apparatfabrikanten. Brukt batteri returneres apparatleverandøren.

Warning: Explosionsfara vid felaktigt batteribyte. Använd samma batterityp eller en ekvivalent typ som rekommenderas av apparattillverkaren. Kassera använt batteri enligt fabrikantens instruktion.

Varoitus: Paristo voi räjähtää, jos se on virheellisesti asennettu. Vaihda paristo ainoastaan laitevalmistajan suosittelemaan tyyppiin. Hävitä käytetty paristo valmistajan ohjeiden mukaisesti.

1. Locate the battery on the server board.
2. Gently press the metal clip as shown to release the battery (see letter **A**).
3. Remove the battery from the pastic socket (see letter **B**).

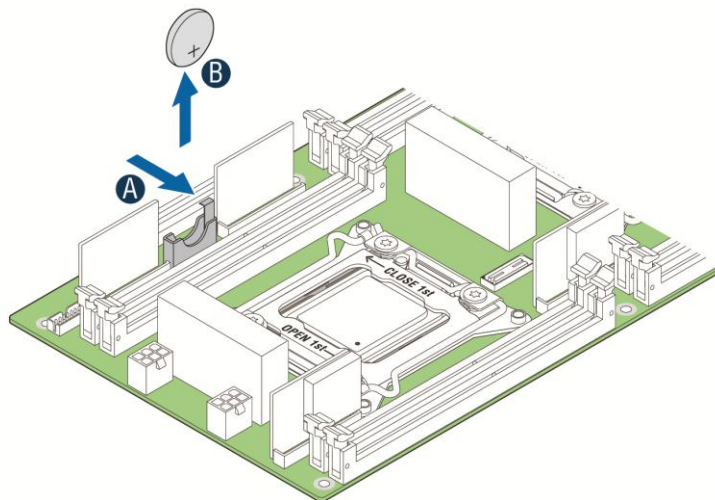

AF004699

Figure 73. Replacing the Backup Battery

Replacing the Front Control Panel board

Removing the Front Control Panel

1. Loosen and remove four screws on the back of handle. Be careful of the control panel cable on the back.

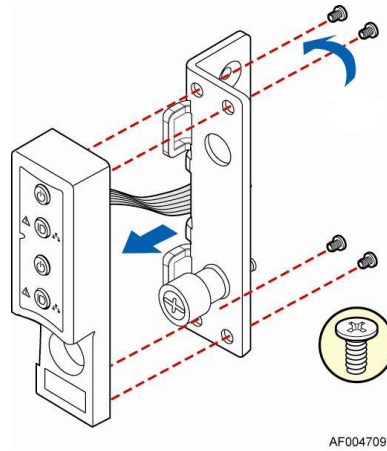

Figure 74. Removing FP Assembly from Rack Handle

2. Disconnect the cable from the control panel board.

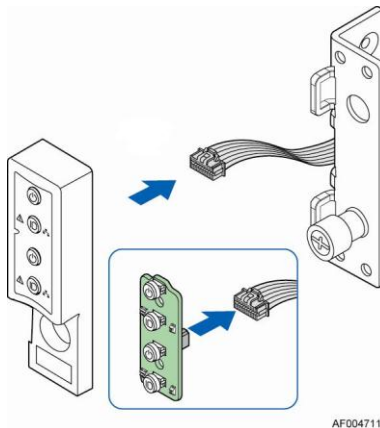

Figure 75. Disconnecting Control Panel Cable

3. Loosen and remove two screws from back of control panel board, so the board can be removed out.

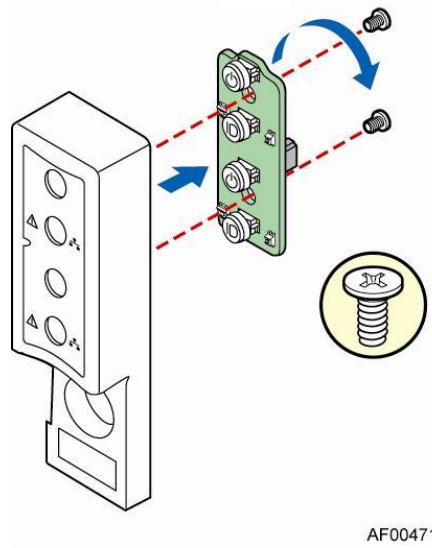

Figure 76. Removing Control Panel Board

Installing Front Control Panel Board

1. Install front control panel board to panel shell.

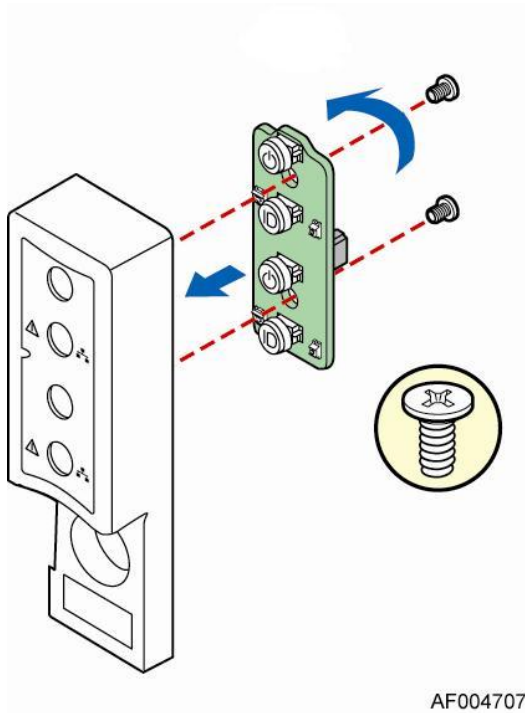

Figure 77. Installing Control Panel Board

2. Connect cable to front panel board.

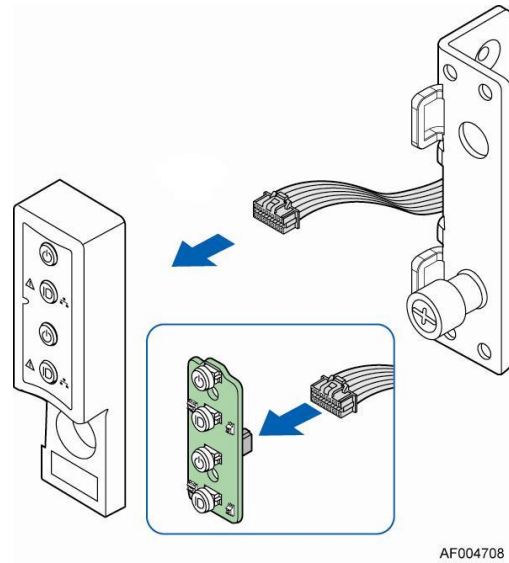

Figure 78. Connecting Cable to Front Panel Board

3. Install front control panel assembly to chassis handle.

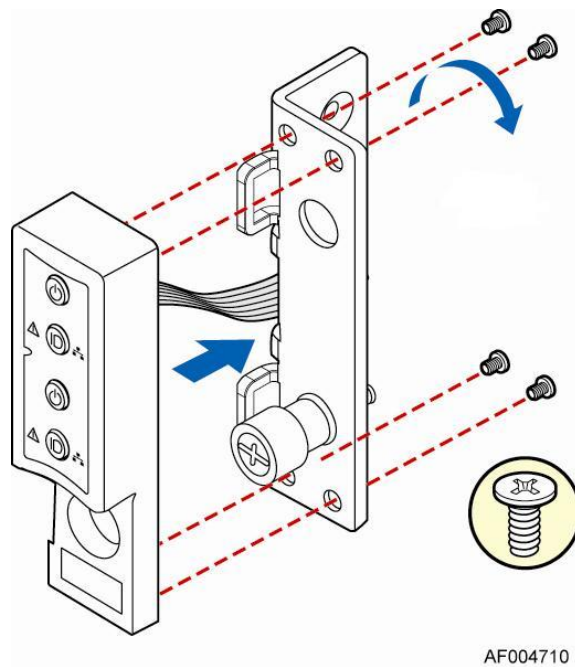

Figure 79. Installing Control Panel Assembly to Rack Handle

Rack Mounting the Chassis

Mounting the Chassis to Rack

The slide rail kit, which is bundled with Intel® Server System H2000JF family is packed in the same shipping box together with the chassis. Following are the steps to install chassis to rack:

1. Preparation before slide installation.

RACK INSTALLATION – REMOVE INNER MEMBER FROM SLIDES

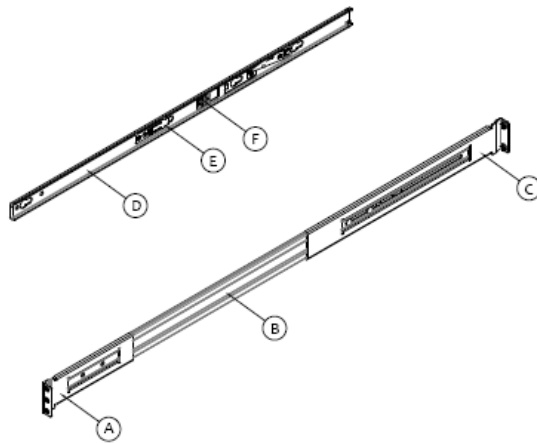

Slides components:
A - front bracket; B - outer member;
C - rear bracket; D - inner member;
E - safety locking pin; F - release button.

Pull release button to remove inner member from slides.

2. Install slides to rack.

RACK INSTALLATION – INSTALL SLIDES TO RACK

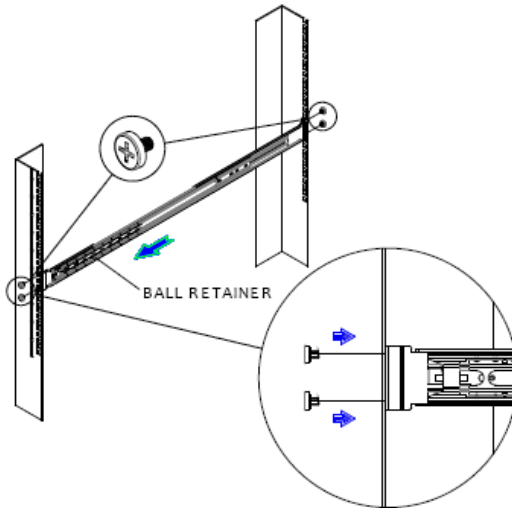

Align brackets to desired vertical position on rack and insert fasteners.
Move ball retainer to the front of slides.

3. Install inner members to chassis.

CHASSIS INSTALLATION – INSTALL INNER MEMBER TO CHASSIS

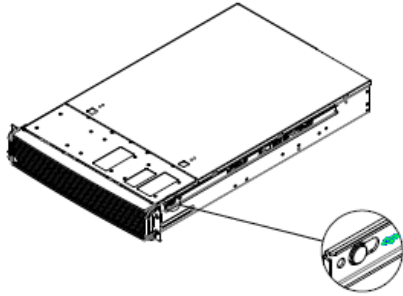

Align inner member key holes to standoffs on chassis, move inner member following the direction in left pictures.

4. Install chassis to fixed slides.

CHASSIS INSTALLATION – INSTALL CHASSIS TO FIXED SLIDES

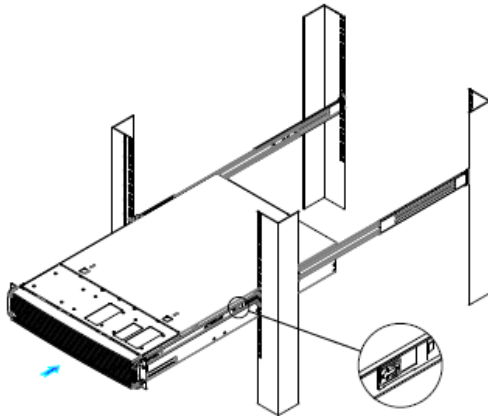

Pull the release button in the inner member to release the lock and allow the chassis to close.

Figure 80. Installing the Chassis to Rack

Removing the Chassis from Rack

Following the below steps to remove the chassis from Rack.

1. Extend slides.

CHASSIS REMOVAL – EXTEND SLIDES

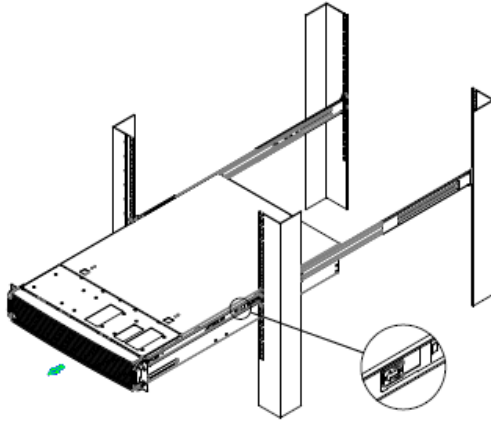

Fully extend the slides until it is in the locked position, pull the release button to release lock and disconnect inner member from slides.

2. Remove Inner Member from Chassis.

CHASSIS REMOVAL – REMOVE INNER MEMBER FROM CHASSIS

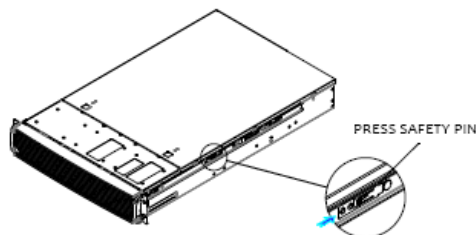

Press safety locking pin to release inner member from chassis.

Figure 81. Removing the Chassis from Rack

3 Server Utilities

Using the BIOS Setup Utility

This section describes the BIOS Setup Utility options, which is used to change server configuration defaults. You can run BIOS Setup with or without an operating system being present.

Starting Setup

To enter the BIOS Setup using a keyboard (or emulated keyboard); press the <F2> function key during boot time when the OEM or Intel® logo is displayed. The following message is displayed on the diagnostics screen and under the Quiet Boot logo screen:

Press <F2> to enter setup

When the Setup Utility is entered, the Main screen is displayed. However, serious errors cause the system to display the Error Manager screen instead of the Main screen.

Setup Navigation Keyboard Commands

The bottom right portion of the Setup screen provides a list of commands that are used to navigate through the Setup utility. These commands are displayed at all times.

Each Setup menu page contains a number of features. Each feature is associated with a value field, except those used for informative purposes. Each value field contains configurable parameters. Depending on the security option chosen and in effect by the password, a menu feature's value may or may not be changed. If a value cannot be changed, its field is made inaccessible and appears grayed out.

Table 6. BIOS Setup: Keyboard Command Bar

Key	Option	Description
<Enter>	Execute Command	The <Enter> key is used to activate submenus when the selected feature is a submenu, or to display a pick list if a selected option has a value field, or to select a subfield for multi-valued features like time and date. If a pick list is displayed, the <Enter> key selects the currently highlighted item, undoes the pick list, and returns the focus to the parent menu.
<Esc>	Exit	The <Esc> key provides a mechanism for backing out of any field. When the <Esc> key is pressed while editing any field or selecting features of a menu, the parent menu is re-entered. When the <Esc> key is pressed in any submenu, the parent menu is re-entered. When the <Esc> key is pressed in any major menu, the exit confirmation window is displayed and the user is asked whether changes can be discarded. If "No" is selected and the <Enter> key is pressed, or if the <Esc> key is pressed, the user is returned to where they were before <Esc> was pressed, without affecting any existing settings. If "Yes" is selected and the <Enter> key is pressed, the setup is exited and the BIOS returns to the main System Options Menu screen.
↑	Select Item	The up arrow is used to select the previous value in a pick list, or the previous option in a menu item's option list. The selected item must then be activated by pressing the <Enter> key.
↓	Select Item	The down arrow is used to select the next value in a menu item's option list, or a value field's pick list. The selected item must then be activated by pressing the <Enter> key.

Key	Option	Description
□	Select Menu	The left and right arrow keys are used to move between the major menu pages. The keys have no effect if a sub-menu or pick list is displayed.
<Tab>	Select Field	The <Tab> key is used to move between fields. For example, <Tab> can be used to move from hours to minutes in the time item in the main menu.
-	Change Value	The minus key on the keypad is used to change the value of the current item to the previous value. This key scrolls through the values in the associated pick list without displaying the full list.
+	Change Value	The plus key on the keypad is used to change the value of the current menu item to the next value. This key scrolls through the values in the associated pick list without displaying the full list. On 106-key Japanese keyboards, the plus key has a different scan code than the plus key on the other keyboards, but will have the same effect.
<F9>	Setup Defaults	<p>Pressing the <F9> key causes the following to display:</p> <div style="border: 1px solid black; padding: 10px; text-align: center;"> <p>Load Optimized Defaults?</p> <p>Yes No</p> </div> <p>If “Yes” is highlighted and <Enter> is pressed, all Setup fields are set to their default values. If “No” is highlighted and <Enter> is pressed, or if the <Esc> key is pressed, the user is returned to where they were before <F9> was pressed without affecting any existing field values.</p>
<F10>	Save and Exit	<p>Pressing the <F10> key causes the following message to display:</p> <div style="border: 1px solid black; padding: 10px; text-align: center;"> <p>Save configuration and reset?</p> <p>Yes No</p> </div> <p>If “Yes” is highlighted and <Enter> is pressed, all changes are saved and the Setup is exited. If “No” is highlighted and <Enter> is pressed, or the <Esc> key is pressed, the user is returned to where they were before <F10> was pressed without affecting any existing values.</p>

Setup Screen Menu Selection Bar

The Setup Screen Menu selection bar is located at the top of the BIOS Setup Utility screen. It displays tabs showing the major screen selections available to the user. By using the left and right arrow keys, the user can select the listed screens. Some screen selections are out of the visible menu space, and become available by scrolling to the left or right of the current selections displayed.

BIOS Setup Utility Screens

The following sections describe the screens available in the BIOS Setup utility for the configuration of the server platform.

For each of these screens, there is an image of the screen with a list of Field Descriptions which describe the contents of each item on the screen. Each item on the screen is hyperlinked to the relevant Field Description. Each Field Description is hyperlinked back to the screen image.

These lists follow the following guidelines:

- The text heading for each Field Description is the actual text as displayed on the BIOS Setup screen. This screen text is a hyperlink to its corresponding Field Description.

- The text shown in the Option Values and Help Text entries in each Field Description are the actual text and values are displayed on the BIOS Setup screens.
- In the Option Values entries, the text for default values is shown with an underline. These values do not appear underline on the BIOS Setup screen. The underlined text in this document is to serve as a reference to which value is the default value.
- The Help Text entry is the actual text which appears on the screen to accompany the item when the item is the one in focus (active on the screen).
- The Comments entry provides additional information where it may be helpful. This information does not appear on the BIOS Setup screens.
- Information enclosed in angular brackets (< >) in the screen shots identifies text that can vary, depending on the option(s) installed. For example, <Amount of memory installed> is replaced by the actual value for “Total Memory”.
- Information enclosed in square brackets ([]) in the tables identifies areas where the user must type in text instead of selecting from a provided option.
- Whenever information is changed (except Date and Time), the systems requires a save and reboot to take place in order for the changes to take effect. Alternatively, pressing <ESC> discards the changes and resumes POST to continue to boot the system according to the boot order set from the last boot.

Map of Screens and Functionality

There are a number of screens in the entire Setup collection. They are organized into major categories. Each category has a hierarchy beginning with a top-level screen from which lower-level screens may be selected. Each top-level screen appears as a tab, arranged across the top of the Setup screen image of all top-level screens.

There are more categories than will fit across the top of the screen, so at any given time there will be some categories which will not appear until the user has scrolled across the tabs which are present. The categories and the screens included in each category are listed below.

Table 7. Screen Map

Categories (Top Tabs)	2 nd Level Screens	3 rd Level Screens
Main Screen (Tab)		
Advanced Screen (Tab)		
↳	Processor Configuration	
↳	Memory Configuration	
	↳	Memory RAS and Performance Configuration
↳	Mass Storage Controller Configuration	
↳	PCI Configuration	

Server Utilities

Categories (Top Tabs)	2 nd Level Screens	3 rd Level Screens
↕	Serial Port Configuration	
↕	USB Configuration	
↕	System Acoustic and Performance Configuration	
Security Screen (Tab)		
Server Management Screen (Tab)		
↕	Console Redirection	
↕	System Information	
↕	BMC LAN Configuration	
Boot Option Screen (Tab)		
↕	CDROM Option	
↕	Hard Disk Order	
↕	Floppy Option	
↕	Network Device Order	
↕	BEV Device Order	
↕	Add EFI Boot Option	
↕	Delete EFI Boot Option	
Boot Manager Screen (Tab)		
Error Manager Screen (Tab)		
Exit Screen (Tab)		

Appendix A: Technical Reference

Power Supply Input Voltages

Table 8. CRPS Input Voltage

Parameter	Min	Rated	Max	Start up VAC	Power Off VAC
110V _{AC}	90 V _{rms}	100-127 V _{rms}	140 V _{rms}	85 V _{AC} ± 4V _{AC}	70V _{AC} ±5V _{AC}
220V _{AC}	180 V _{rms}	200-240 V _{rms}	264 V _{rms}		
Frequency	47 Hz	50/60 Hz	63 Hz		

Power Supply Output Voltages

Table 9. CRPS Output Voltage

Parameter	Min	Nom	Max	Unit	Tolerance
+12V _{STB}	+11.40V	+12.000V	+12.60V	Vrms	±5%
+12V	+11.40V	+12.000V	+12.60V	Vrms	±5%

System Environmental Specifications

The following table defines the system level operating and non-operating environmental limits.

Table 10. System Environmental Limits Summary

Parameter	Limits
Operating Temperature	+10°C to +35°C with the maximum rate of change not to exceed 10°C per hour.
Non-Operating Temperature	-40°C to +70°C
Non-Operating Humidity	90%, non-condensing at 35°C
Acoustic noise	Sound power: <ul style="list-style-type: none"> ▪ 3.5" HDD SKU: 6.9BA at idle and 7.4BA at active mode ▪ 2.5" HDD SKU: 6.5BA at idle and 7.07BA at active mode In typical office ambient temperature. (23 +/- 2 degrees C).
Shock, operating	Half sine, 2 g peak, 11 milliseconds
Shock, unpackaged	Trapezoidal, 25 g, velocity change 205 inches/second (80 lbs to < 100 lbs)

Appendix A: Technical Reference

Parameter	Limits
Shock, packaged	Non-palletized free fall in height 18 inches (80 lbs to < 100 lbs)
Vibration, unpackaged	5 Hz to 500 Hz, 2.20 g RMS random
ESD	+/-12 KV except I/O port +/- 8 KV per <i>Intel® Environmental Test Specification</i> .
System Cooling Requirement in BTU/Hr	1200 Watt Max – 4095 BTU/hour
	1600 Watt Max – 5459 BTU/hour

Appendix B: Regulatory and Compliance Information

Please refer to the Server Products Regulatory and Safety document for the product regulatory compliance reference. The document can be downloaded from http://www.intel.com/p/en_US/support/server/.

Appendix C: LED Decoder

During the system boot process, the BIOS executes a number of platform configuration processes, each of which is assigned a specific hex POST code number. As each configuration routine is started, the BIOS displays the POST code to the POST Code

Diagnostic LEDs found on the back edge of the server board. To assist in troubleshooting a system hang during the POST process, the Diagnostic LEDs can be used to identify the last POST process to be executed.

Each POST code is represented by the eight amber Diagnostic LEDs. The POST codes are divided into two nibbles, an upper nibble and a lower nibble. The upper nibble bits are represented by Diagnostic LEDs #4, #5, #6, #7. The lower nibble bits are represented by Diagnostics LEDs #0, #1, #2 and #3. If the bit is set in the upper and lower nibbles, then the corresponding LED is lit. If the bit is clear, then the corresponding LED is off.

The Diagnostic LED #7 is labeled as "MSB", and the Diagnostic LED #0 is labeled as "LSB".

In the following example, the BIOS sends a value of ACh to the diagnostic LED decoder.

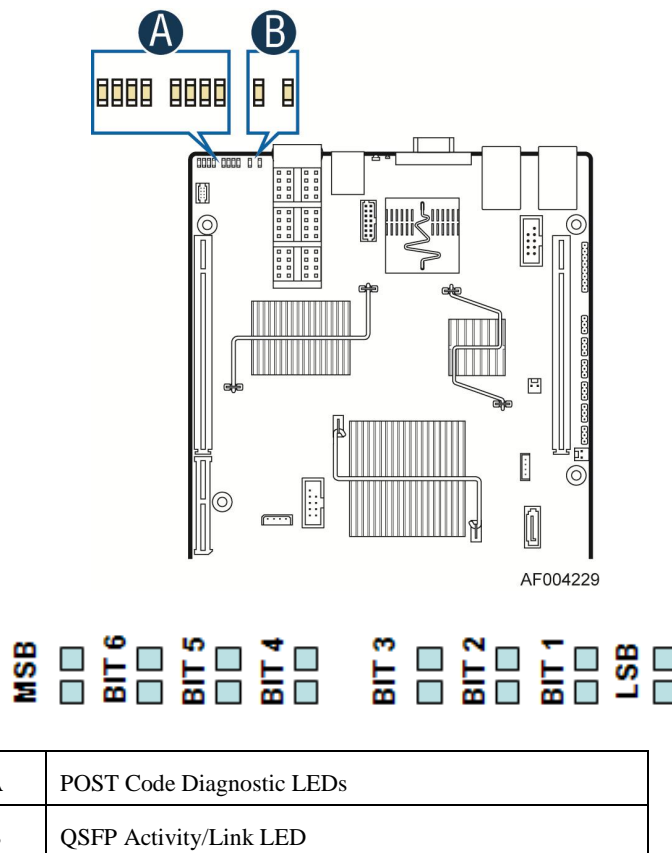

Figure 82. Diagnostic LED Placement Diagram

The LEDs are decoded as follows:

Table 11. POST Progress Code LED Example

LEDs	Upper Nibble LEDs				Lower Nibble LEDs			
	MSB							LSB
	LED #7	LED #6	LED #5	LED #4	LED #3	LED #2	LED #1	LED #0
	8h	4h	2h	1h	8h	4h	2h	1h
Status	ON	OFF	ON	OFF	ON	ON	OFF	OFF
Results	1	0	1	0	1	1	0	0
	Ah				Ch			

• Upper nibble bits = 1010b = Ah;

• Lower nibble bits = 1100b = Ch;

The two are concatenated as Ach.

Table 12. Diagnostic LED POST Code Decoder

Checkpoint	Diagnostic LED Decoder								Description
	1 = On, 0=Off								
	Upper Nibble				Lower Nibble				
	MSB							LSB	
LED	#7	#6	#5	#4	#3	#2	#1	#0	
Host Processor									
0x10h	0	0	0	1	0	0	0	0	Power-on initialization of the host processor (bootstrap processor)
0x11h	0	0	0	1	0	0	0	1	Host processor cache initialization (including AP)
0x12h	0	0	0	1	0	0	1	0	Starting application processor initialization
0x13h	0	0	0	1	0	0	1	1	SMM initialization
0x14h	0	0	0	1	0	1	0	0	Selection of Processor with least features to be used as Boot Strap Processor
0x15h	0	0	0	1	0	1	0	1	Switch an AP processor to become the new Boot Strap Processor
Chipset									
0x21h	0	0	1	0	0	0	0	1	Initializing a chipset component
Memory									
0x22h	0	0	1	0	0	0	1	0	Reading configuration data from memory (SPD on FBDIMM)
0x23h	0	0	1	0	0	0	1	1	Detecting presence of memory
0x24h	0	0	1	0	0	1	0	0	Programming timing parameters in the memory controller
0x25h	0	0	1	0	0	1	0	1	Configuring memory parameters in the memory controller
0x26h	0	0	1	0	0	1	1	0	Optimizing memory controller settings
0x27h	0	0	1	0	0	1	1	1	Initializing memory, such as ECC init
0x28h	0	0	1	0	1	0	0	0	Testing memory
0xE4h	1	1	1	0	0	1	0	0	BIOS cannot communicate with DIMM (serial channel hardware failure)
0xE6h	1	1	1	0	0	1	1	0	DIMM(s) failed Memory iBIST or Memory Link Training failure
0xE8h	1	1	1	0	1	0	0	0	No memory available (system halted)
0xE9h	1	1	1	0	1	0	0	1	Unsupported or invalid DIMM configuration (system halted)

Appendix C: LED Decoder

Checkpoint	Diagnostic LED Decoder								Description
	1 = On, 0=Off								
	Upper Nibble				Lower Nibble				
	MSB							LSB	
LED	8h	4h	2h	1h	8h	4h	2h	1h	
	#7	#6	#5	#4	#3	#2	#1	#0	
0xEAh	1	1	1	0	1	0	1	0	DIMM training sequence failed (system halted)
0xEBh	1	1	1	0	1	0	1	1	Memory test failed (system halted)
0xECh	1	1	1	0	1	1	0	0	Unsupported or invalid DIMM configuration (system halted)
0xEDh	1	1	1	0	1	1	0	1	Unsupported or invalid DIMM configuration (system halted)
0xEBh	1	1	1	0	1	0	1	1	DIMM with corrupted SPD data detected (system halted)
QuickPath Interconnect (QPI)									
0xA0h	1	0	1	0	0	0	0	0	QPI Initialization
0xA1h	1	0	1	0	0	0	0	1	QPI Initialization
0xA2h	1	0	1	0	0	0	1	0	QPI Initialization
0xA3h	1	0	1	0	0	0	1	1	QPI Initialization
0xA4h	1	0	1	0	0	1	0	0	QPI Initialization
0xA5h	1	0	1	0	0	1	0	1	QPI Initialization
0xA6h	1	0	1	0	0	1	1	0	QPI Initialization
0xA7h	1	0	1	0	0	1	1	1	QPI Initialization
0xA8h	1	0	1	0	1	0	0	0	QPI Initialization
0xA9h	1	0	1	0	1	0	0	1	QPI Initialization
0xAAh	1	0	1	0	1	0	1	0	QPI Initialization
0xABh	1	0	1	0	1	0	1	1	QPI Initialization
0xACh	1	0	1	0	1	1	0	0	QPI Initialization
0xADh	1	0	1	0	1	1	0	1	QPI Initialization
0xAEh	1	0	1	0	1	1	1	0	QPI Initialization
0xAFh	1	0	1	0	1	1	1	1	QPI Initialization
Integrated Memory Controller (IMC)									
0xB0h	1	0	1	1	0	0	0	0	Memory Initialization of Integrated Memory Controller
0xB1h	1	0	1	1	0	0	0	1	Memory Initialization of Integrated Memory Controller
0xB2h	1	0	1	1	0	0	1	0	Memory Initialization of Integrated Memory Controller
0xB3h	1	0	1	1	0	0	1	1	Memory Initialization of Integrated Memory Controller
0xB4h	1	0	1	1	0	1	0	0	Memory Initialization of Integrated Memory Controller
0xB5h	1	0	1	1	0	1	0	1	Memory Initialization of Integrated Memory Controller
0xB6h	1	0	1	1	0	1	1	0	Memory Initialization of Integrated Memory Controller
0xB7h	1	0	1	1	0	1	1	1	Memory Initialization of Integrated Memory Controller
0xB8h	1	0	1	1	1	0	0	0	Memory Initialization of Integrated Memory Controller
0xB9h	1	0	1	1	1	0	0	1	Memory Initialization of Integrated Memory Controller
0xBAh	1	0	1	1	1	0	1	0	Memory Initialization of Integrated Memory Controller
0xBBh	1	0	1	1	1	0	1	1	Memory Initialization of Integrated Memory Controller
0xBCh	1	0	1	1	1	1	0	0	Memory Initialization of Integrated Memory Controller
0xBDh	1	0	1	1	1	1	0	1	Memory Initialization of Integrated Memory Controller
0xBEh	1	0	1	1	1	1	1	0	Memory Initialization of Integrated Memory Controller
0xBFh	1	0	1	1	1	1	1	1	Memory Initialization of Integrated Memory Controller
PCI Bus									

Checkpoint	Diagnostic LED Decoder								Description
	1 = On, 0=Off								
	Upper Nibble				Lower Nibble				
	MSB							LSB	
LED	8h	4h	2h	1h	8h	4h	2h	1h	#0
	#7	#6	#5	#4	#3	#2	#1	#0	
0x50h	0	1	0	1	0	0	0	0	Enumerating PCI buses
0x51h	0	1	0	1	0	0	0	1	Allocating resources to PCI buses
0x52h	0	1	0	1	0	0	1	0	Hot Plug PCI controller initialization
0x53h	0	1	0	1	0	0	1	1	Reserved for PCI bus
0x54h	0	1	0	1	0	1	0	0	Reserved for PCI bus
0x55h	0	1	0	1	0	1	0	1	Reserved for PCI bus
USB									
0x56h	0	1	0	1	0	1	1	0	Initializing USB host controllers
0x57h	0	1	0	1	0	1	1	1	Detecting USB devices
0x58h	0	1	0	1	1	0	0	0	Resetting USB bus
0x59h	0	1	0	1	1	0	0	1	Reserved for USB devices
ATA/ATAPI/SATA									
0x5Ah	0	1	0	1	1	0	1	0	Resetting SATA bus and all devices
0x5Bh	0	1	0	1	1	0	1	1	Detecting the presence of ATA device
0x5Ch	0	1	0	1	1	1	0	0	Enable SMART if supported by ATA device
0x5Dh	0	1	0	1	1	1	0	1	Reserved for ATA
SMBUS									
0x5Eh	0	1	0	1	1	1	1	0	Resetting SMBUS
0x5Fh	0	1	0	1	1	1	1	1	Reserved for SMBUS
I/O Controller Hub									
0x61h	0	1	1	0	0	0	0	1	Initializing I/O Controller Hub
Super I/O									
0x63h	0	1	1	0	0	0	1	1	Initializing Super I/O
Local Console									
0x70h	0	1	1	1	0	0	0	0	Resetting the video controller (VGA)
0x71h	0	1	1	1	0	0	0	1	Disabling the video controller (VGA)
0x72h	0	1	1	1	0	0	1	0	Enabling the video controller (VGA)
0x73h	0	1	1	1	0	0	1	1	Reserved for video controller (VGA)
Remote Console									
0x78h	0	1	1	1	1	0	0	0	Resetting the console controller
0x79h	0	1	1	1	1	0	0	1	Disabling the console controller
0x7Ah	0	1	1	1	1	0	1	0	Enabling the console controller
0x7Bh	0	1	1	1	1	0	1	1	Reserved for console controller
Keyboard (only USB)									
0x90h	1	0	0	1	0	0	0	0	Resetting the keyboard
0x91h	1	0	0	1	0	0	0	1	Disabling the keyboard
0x92h	1	0	0	1	0	0	1	0	Detecting the presence of the keyboard
0x93h	1	0	0	1	0	0	1	1	Enabling the keyboard
0x94h	1	0	0	1	0	1	0	0	Clearing keyboard input buffer
0x96h	1	0	0	1	0	1	1	0	Reserved for keyboard
Mouse (only USB)									

Appendix C: LED Decoder

Checkpoint	Diagnostic LED Decoder								Description
	1 = On, 0=Off								
	Upper Nibble				Lower Nibble				
	MSB							LSB	
LED	8h	4h	2h	1h	8h	4h	2h	1h	
	#7	#6	#5	#4	#3	#2	#1	#0	
0x98h	1	0	0	1	0	0	1	0	Resetting the mouse
0x99h	1	0	0	1	0	0	1	1	Detecting the mouse
0x9Ah	1	0	0	1	0	1	1	0	Detecting the presence of mouse
0x9Bh	1	0	0	1	0	1	1	1	Enabling the mouse
0x9Ch	1	0	0	1	0	0	1	0	Reserved for mouse
Serial Port									
0xA8h	1	0	1	0	1	0	0	0	Resetting the serial port
0xA9h	1	0	1	0	1	0	0	1	Disabling the serial port
0xAAh	1	0	1	0	1	0	1	0	Detecting the presence of the serial port
0xABh	1	0	1	0	1	0	1	1	Clearing serial port buffer
0xACh	1	0	1	0	1	1	0	0	Enabling serial port
0xADh	1	0	1	0	1	1	0	1	Reserved for serial port
Fixed Media									
0xB0h	1	0	1	1	0	0	0	0	Resetting fixed media device
0xB1h	1	0	1	1	0	0	0	1	Disabling fixed media device
0xB2h	1	0	1	1	0	0	1	0	Detecting presence of a fixed media device (SATA hard drive detection, and so forth)
0xB3h	1	0	1	1	0	0	1	1	Enabling/configuring a fixed media device
0xB4h	1	0	1	1	0	1	0	0	Reserved for fixed media
Removable Media									
0xB8h	1	0	1	1	1	0	0	0	Resetting removable media device
0xB9h	1	0	1	1	1	0	0	1	Disabling removable media device
0xBAh	1	0	1	1	1	0	1	0	Detecting presence of a removable media device (SATA CDROM detection, and so forth)
0xBCh	1	0	1	1	1	1	0	0	Enabling/configuring a removable media device
0xBDh	1	0	1	1	1	1	0	1	Reserved for removable media device
Boot Device Selection (BDS)									
0xD0	1	1	0	1	0	0	0	0	Entered the Boot Device Selection phase (BDS)
0xD1	1	1	0	1	0	0	0	1	Return to last good boot device
0xD2	1	1	0	1	0	0	1	0	Setup boot device selection policy
0xD3	1	1	0	1	0	0	1	1	Connect boot device controller
0xD4	1	1	0	1	0	1	0	0	Attempt flash update boot mode
0xD5	1	1	0	1	0	1	0	1	Transfer control to EFI boot
0xD6	1	1	0	1	0	1	1	0	Trying to boot device selection
0xDF	1	1	0	1	1	1	1	1	Reserved for boot device selection
Pre-EFI Initialization (PEI) Core									
0xE0h	1	1	1	0	0	0	0	0	Entered Pre-EFI Initialization phase (PEI)
0xE1h	1	1	1	0	0	0	0	1	Started dispatching early initialization modules (PEIM)
0xE2h	1	1	1	0	0	0	1	0	Initial memory found, configured, and installed correctly
0xE3h	1	1	1	0	0	0	1	1	Transfer control to the DXE Core
PEI Modules									

Checkpoint	Diagnostic LED Decoder								Description
	1 = On, 0=Off								
	Upper Nibble				Lower Nibble				
	MSB							LSB	
LED	8h	4h	2h	1h	8h	4h	2h	1h	
	#7	#6	#5	#4	#3	#2	#1	#0	
0xF0h	1	1	1	1	0	0	0	0	Install PEIM for Platform Status Codes
0xF1h	1	1	1	1	0	0	0	1	Detecting Platform Type
0xF2h	1	1	1	1	0	0	1	0	Early Platform Initialization
0xF3h	1	1	1	1	0	0	1	1	PEI Modules initialized
Driver eXecution Environment (DXE) Core									
0xE4h	1	1	1	0	0	1	0	0	Entered EFI driver execution phase (DXE)
0xE5h	1	1	1	0	0	1	0	1	Started dispatching drivers
0xE6h	1	1	1	0	0	1	1	0	Started connecting drivers
DXE Drivers									
0xE7h	1	1	1	0	1	1	0	1	Waiting for user input
0xE8h	1	1	1	0	1	0	0	0	Checking password
0xE9h	1	1	1	0	1	0	0	1	Entering BIOS setup
0xEAh	1	1	1	0	1	1	0	0	Flash Update
0xEBh	1	1	1	0	1	1	0	1	Legacy Option ROM initialization
0xECh	1	1	1	0	1	0	0	0	DXE Drivers initialized
0xEDh	1	1	1	0	1	0	0	1	Transfer control to Boot Device Selection (BDS)
0xEEh	1	1	1	0	1	1	0	0	Calling Int 19. One beep unless silent boot is enabled.
0xEFh	1	1	1	0	1	1	0	1	Unrecoverable boot failure
Pre-EFI Initialization Module (PEIM)/Recovery									
0x30h	0	0	1	1	0	0	0	0	Crisis recovery initiated because of a user request
0x31h	0	0	1	1	0	0	0	1	Crisis recovery initiated by software (corrupt flash)
0x34h	0	0	1	1	0	1	0	0	Loading crisis recovery capsule
0x35h	0	0	1	1	0	1	0	1	Handing off control to the crisis recovery capsule
0x36h	0	0	1	1	0	1	1	0	Begin crisis recovery
0x3Eh	0	0	1	1	1	1	1	0	No crisis recovery capsule detected
0x3Fh	0	0	1	1	1	1	1	1	Crisis recovery capsule failed integrity check of capsule descriptors

Appendix D: Getting Help

If you encounter an issue with your server system, follow these steps to obtain support:

1. Visit the following Intel support web page at http://www.intel.com/p/en_US/support/server/. This web page provides 24x7 support when you need it to get the latest and most complete technical support information on all Intel Enterprise Server and Storage Platforms. Information available at the support site includes:
 - Latest BIOS, firmware, drivers and utilities
 - Product documentation, installation and quick start guides
 - Full product specifications, technical advisories and errata
 - Compatibility documentation for memory, hardware add-in cards, chassis support matrix and operating systems
 - Server and chassis accessory parts list for ordering upgrades or spare parts
 - A searchable knowledgebase to search for product information throughout the support site
2. If you are still unable to obtain a solution to your issue, send an email to Intel's technical support center using the online form available at <http://supportmail.intel.com/scripts-emf/welcome.aspx>.
3. Lastly, you can contact an Intel support representative using one of the support phone numbers available at http://www.intel.com/p/en_US/support/contact/phone (charges may apply). Intel customer support suggests filling out the issue report form available at Appendix E: Intel® Server Issue Report Form to better service the issue.

Intel also offers Channel Program members around-the-clock 24x7 technical phone support on Intel® server boards, server chassis, server RAID controller cards, and Intel® Server Management at <http://www.intel.com/reseller/>.

Note: You will need to log in to the Reseller site to obtain the 24x7 number.

Warranty Information

To obtain warranty information, visit the following Intel web site:

<http://www.intel.com/support/motherboards/server/sb/cs-010807.htm>

Appendix E: Intel® Server Issue Report Form

Issue Report Form (Rev 3.6)

Note: Filling out this form completely is required for any escalation.

Customer Contact Information:

Customer Support Case#:

Intel® Server Board or System:

(Example: S2600JF, H2216JF/H2312JF)

Server Chassis:

(Example P4000M. If third-party chassis used, indicate make and model.)

Base Board Information: (some information maybe found by accessing BIOS & going through the Server Management menu -> System Information)

Baseboard PBA/TA/AA # (Example: 123456-789):

- can be found on the white sticker label on the baseboard.

System BIOS Version:

Intel® Remote Management Module Firmware Version (if applicable):

Intel® Management Module BMC Revision (if applicable):

BMC/mBMC Version:

FRU/SDR Version:

HSC Version:

Has the latest BIOS been tried? (Yes/No):

Has the latest BMC/mBMC been tried? (Yes/No):

Has the latest IMM BMC been tried? (Yes/No):

Has the latest RMM Firmware been tried? (Yes/No):

Has the latest FRU/SDR been tried? (Yes/No):

Has the latest HSC been tried? (Yes/No):

Processor information:

	Type	Speed	Spec	Thermal Solution
Processor 1				
Processor 2				
Processor 3				
Processor 4				

Thermal solution (Heat sink) examples:

(1U, Passive w/air ducting, Active w/fan, and so on)

Memory:

Manufacturer	Part Number	DRAM Part Number	On Intel tested list?

Add-in adapters (Example: NICs, Management Adapters, Serial Expansion Cards, PCI-Express* Adapters, RAID Controllers, SCSI Controllers, and so on):

Type	Slot	Manufacturer	Model	Firmware

Other third part hardware (Example: Example: KVM, Chassis, and so on):

Description/Use	Manufacturer	Model	Firmware

Storage Devices (Example: SCSI, SATA, SAS, USB, Tape, and so on):

Manufacturer	Model	Type	Size	Firmware	In Hot Swap Bay?

Operating System Information (Example: RedHat* Enterprise Linux, Microsoft Windows Server 2003*, Service Pack 1, OEM CD):

Manufacturer:

Version:

Language version (English, Arabic, and Chinese (Simplified)):

Service Pack Level or Kernel Revision:

Distribution (OEM/Retail):

Intel® RAID Controller: (Example SRCU42E)

RAID controller part number (PBA number):

RAID controller firmware version:

Has the latest RAID firmware been tried? (Yes/No):

RAID driver version:

Has the latest RAID driver been tried? (Yes/No):

RAID volumes configuration (disks & RAID level):

RAID volume use (Boot device/Data Volume):

Is BBU (Battery Backup Unit) installed? (Yes/No):

BBU part number:

Appendix E: Intel® Server Issue Report Form

Detailed description of issue:

Troubleshooting tried:

Steps to replicate the issue:

Issue impact statements:

Do you have any potential Intel system, or component purchases that this issue is holding up? If yes, please provide a brief description below.

Do you have systems already purchased that are not being delivered to your customers because of this issue? If yes, please provide a brief description below.

Have you returned systems or components to your place of purchase because of this issue? If yes, please provide a brief description below.

*All other brands and names are property of their respective owners.