



PM-525 User's Guide

Contents

PM-525 User's Guide	11
Product Basics	12
Using the Control Panel	12
Control Panel Buttons.....	13
The LCD Screen	14
Viewing the Icon List	14
Changing LCD Screen Language.....	15
Turning Off Control Panel Sounds.....	15
Printer Parts	16
Using the Optional Battery	18
Purchase the Optional Battery.....	19
Battery Part Number	19
Installing the Battery	19
Charging the Battery Using the AC Adapter	20
Battery Safety Instructions.....	21
Removing the Handle.....	22
The Power Off and Sleep Timers	23
Changing the Power Off Timer Setting from the Control Panel.....	23
Changing the Sleep Timer Setting from the Control Panel	23
Epson Connect Solutions for Smartphones, Tablets, and More	24
Setting Up Epson Connect Services.....	24
Using Epson Email Print	24
Using the Epson Creative Print Mobile App.....	25
Using the Epson iPrint Mobile App	26
Using Epson Remote Print	26
Using Google Cloud Print.....	27
Using AirPrint	28
Using the Mopria Print Service	28
Android Printing Using the Epson Print Enabler	29

Wi-Fi Networking	30
Wi-Fi Infrastructure Mode Setup.....	30
Selecting Wireless Network Settings from the Control Panel	31
Wi-Fi Direct Mode Setup	33
Enabling Wi-Fi Direct Mode	34
Wi-Fi Protected Setup (WPS).....	34
Using WPS to Connect to a Network	34
Viewing the Network Status	35
Printing a Network Connection Report	35
Changing or Updating Network Connections	36
Accessing the Web Config Utility.....	36
Changing a USB Connection to a Wi-Fi Connection.....	36
Connecting to a New Wi-Fi Router	37
Disabling Wi-Fi Features	37
Loading Paper	39
Loading Paper in the Paper Feed Slot.....	39
Paper Loading Capacity	44
Available Epson Papers	44
Borderless Paper Type Compatibility	45
Paper or Media Type Settings - Product Software.....	45
Selecting the Paper Settings - Control Panel	46
Paper Type Settings - Control Panel	46
Printing from a Computer	48
Printing with Windows	48
Selecting Basic Print Settings - Windows	48
Print Quality Options - Windows	50
Multi-Page Printing Options - Windows.....	51
Selecting Double-sided Printing Settings - Windows	51
Double-sided Printing Options - Windows.....	53
Selecting Additional Layout and Print Options - Windows	53
Custom Color Correction Options - Windows.....	55
Image Options and Additional Settings - Windows.....	56
Selecting a Printing Preset - Windows	57

Selecting Extended Settings - Windows	58
Extended Settings - Windows	59
Printing Your Document or Photo - Windows.....	60
Checking Print Status - Windows	62
Selecting Default Print Settings - Windows.....	62
Changing the Language of the Printer Software Screens	63
Changing Automatic Update Options	64
Printing on a Mac	65
Selecting Basic Print Settings - Mac	66
Print Quality Settings - Mac.....	69
Print Options - Mac	70
Selecting Page Setup Settings - Mac	70
Selecting Print Layout Options - Mac.....	72
Sizing Printed Images - Mac.....	73
Managing Color - Mac	73
Color Matching and Color Options - Mac	74
Selecting Printing Preferences - Mac	75
Printing Preferences - Mac.....	76
Printing Your Document or Photo - Mac	77
Checking Print Status - Mac.....	77
Printing From a Chromebook	78
Cancelling Printing Using a Product Button.....	79
Using Memory Cards with Your Product.....	80
Inserting a Memory Card	80
Memory Card Types	81
Memory Card File Specifications	81
Removing a Memory Card.....	81
Printing from a Memory Card	82
Viewing and Printing Photos.....	83
Printing Photo Layouts	83
Photo Layout Options	84
Print Setting Options.....	85
Photo Adjustment Options.....	86

Transferring Photos on a Memory Card	86
Transferring Photos from a Memory Card to Your Computer	87
Using an External Device with Your Product	88
Printing from a Camera	88
Selecting Print and Photo Adjustment Settings	88
Connecting and Printing from a Camera	89
Printing from a Camera Wirelessly	90
Viewing or Printing from a USB Flash Drive or External Device	90
USB Device File Specifications	90
Connecting and Using a USB Flash Drive or External Device	91
Replacing the Ink Cartridge and Maintenance Box	92
Check Status of the Ink Cartridge and Maintenance Box	92
Checking Cartridge and Maintenance Box Status on the LCD Screen	92
Checking Cartridge and Maintenance Box Status with Windows	93
Checking Cartridge and Maintenance Box Status on a Mac.....	95
Purchase Epson Ink Cartridges and Maintenance Box	96
Ink Cartridge and Maintenance Box Part Numbers.....	96
Removing and Installing the Ink Cartridge.....	97
Replacing the Maintenance Box.....	101
Adjusting Print Quality.....	106
Print Head Maintenance.....	106
Print Head Nozzle Check.....	106
Checking the Nozzles Using the Product Control Panel	106
Checking the Nozzles Using a Computer Utility	108
Print Head Cleaning	109
Cleaning the Print Head Using the Product Control Panel	109
Cleaning the Print Head Using a Computer Utility.....	110
Print Head Alignment	112
Aligning the Print Head Using the Product Control Panel	112
Cleaning the Paper Path	113
Transporting and Cleaning Your Product	116
Carrying and Transporting Your Product.....	116

Cleaning Your Product	118
Solving Problems	120
Checking for Software Updates.....	120
Product Status Messages	121
Running a Product Check	122
Resetting Control Panel Defaults	123
Solving Power and Battery Problems	124
Product Does Not Turn On	124
Product Does Not Turn Off	124
Product Turns Off Automatically	124
Solving Setup Problems	125
Noise After Ink Installation	125
Software Installation Problems	125
USB Connection Problems	126
Solving Network Problems	126
Product Cannot Connect to a Wireless Router or Access Point	126
Network Software Cannot Find Product on a Network.....	128
Product Does Not Appear in Mac Printer Window	129
Cannot Print Over a Network.....	129
Solving Paper Problems	130
Paper Feeding Problems	130
Paper Jam Problems Inside the Product	131
Paper Ejection Problems	134
Solving Problems Printing from a Computer.....	134
Nothing Prints	134
Product Icon Does Not Appear in Windows Taskbar	135
Printing is Slow	136
Solving Page Layout and Content Problems	137
Inverted Image.....	137
Too Many Copies Print	138
Blank Pages Print	138
Incorrect Margins on Printout.....	138
Border Appears on Borderless Prints	139

Incorrect Characters Print.....	139
Incorrect Image Size or Position	140
Slanted Printout	140
Solving Print Quality Problems	140
White or Dark Lines in Printout	141
Blurry or Smearred Printout	141
Faint Printout or Printout Has Gaps	142
Grainy Printout.....	143
Incorrect Colors	144
Solving Memory Card Problems.....	145
Memory Card Does Not Fit Into a Slot	145
Cannot View or Print Photos from a Memory Card or Device	145
Cannot Transfer Photos to or from a Memory Card or Device	146
Uninstall Your Product Software.....	146
Uninstalling Printing Software - Windows	146
Uninstalling Product Software - Mac.....	147
Where to Get Help.....	148
Technical Specifications	151
Windows System Requirements	151
Mac System Requirements	152
Paper Specifications	152
Printable Area Specifications	153
Ink Cartridge Specifications.....	155
Memory Card Specifications	155
External USB Device Specifications.....	156
Dimension Specifications	157
Electrical Specifications	157
Environmental Specifications	159
Interface Specifications	159
Network Interface Specifications	159
Safety and Approvals Specifications	160
Notices	161
FCC Compliance Statement.....	161

Trademarks	162
Copyright Notice.....	162
A Note Concerning Responsible Use of Copyrighted Materials.....	163
Default Delay Times for Power Management for Epson Products	163
Copyright Attribution	163

PM-525 User's Guide

Welcome to the PM-525 *User's Guide*.

For a printable PDF copy of this guide, [click here](#).

Product Basics

See these sections to learn about the basic features of your product.

[Using the Control Panel](#)

[Printer Parts](#)

[Using the Optional Battery](#)

[Removing the Handle](#)

[The Power Off and Sleep Timers](#)

[Epson Connect Solutions for Smartphones, Tablets, and More](#)

[Using Google Cloud Print](#)

[Using AirPrint](#)

[Using the Mopria Print Service](#)

[Android Printing Using the Epson Print Enabler](#)

Using the Control Panel

See these sections to learn about the control panel and select control panel settings.

[Control Panel Buttons](#)

[The LCD Screen](#)









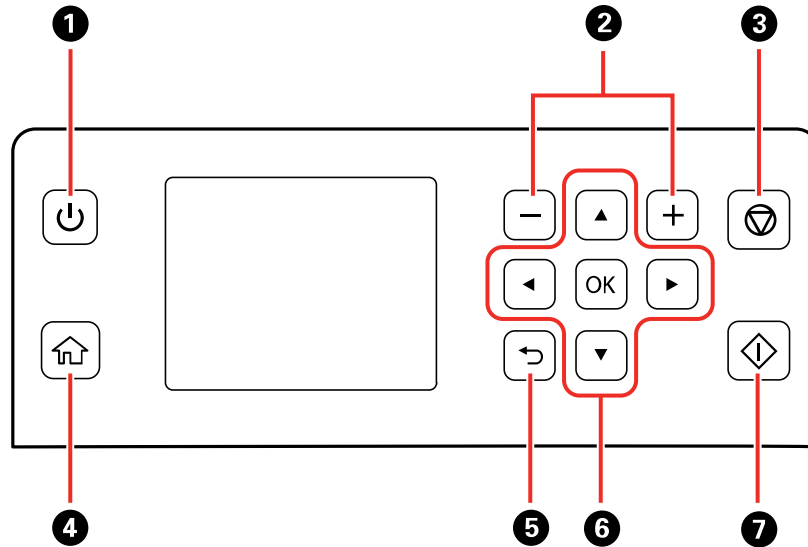

[Changing LCD Screen Language](#)

[Turning Off Control Panel Sounds](#)

Parent topic: [Product Basics](#)

Control Panel Buttons



- 1 The  power button
- 2 The  and  buttons; increase or decrease the number of copies
- 3 The  stop button
- 4 The  home button
- 5 The  back button
- 6 The , , , and  buttons; navigate menus
- 7 The  start button

Parent topic: [Using the Control Panel](#)

The LCD Screen

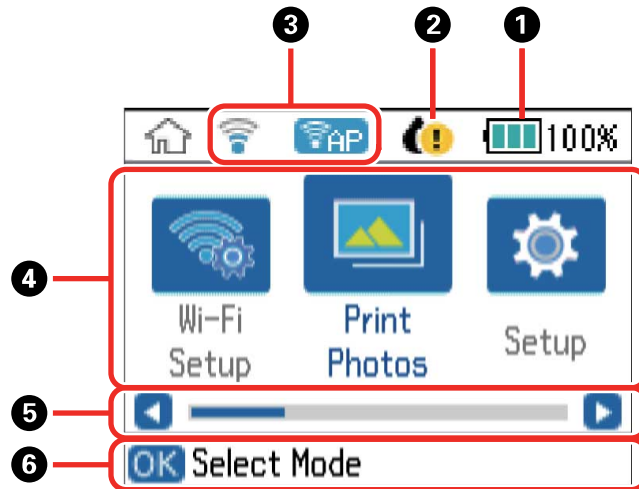

- 1 Displays battery status
- 2 Displays ink cartridge status
- 3 Displays network status
- 4 Menu options
- 5 You can scroll left or right when these arrows are displayed
- 6 Displays available button options

[Viewing the Icon List](#)

Parent topic: [Using the Control Panel](#)

Viewing the Icon List

You can get information about the icons displayed on the control panel by viewing the icon list.

1. Press the  home button, if necessary.
2. Press the arrow buttons to select **Help** and press the **OK** button.
3. Select **Icon List** and press the **OK** button.

4. Press the up or down arrow button to scroll through the icon list.

Parent topic: [The LCD Screen](#)

Changing LCD Screen Language

You can change the language used on the LCD screen.

1. Press the  home button, if necessary.
2. Press the arrow buttons to select **Setup** and press the **OK** button.
3. Select **Printer Setup** and press the **OK** button.
4. Select **Language** and press the **OK** button.
5. Select a language and press the **OK** button.

Parent topic: [Using the Control Panel](#)

Turning Off Control Panel Sounds

You can turn off the sound heard when you press buttons on the control panel.

1. Press the  home button, if necessary.
2. Press the arrow buttons to select **Setup** and press the **OK** button.
3. Select **Printer Setup** and press the **OK** button.
4. Select **Sound** and press the **OK** button.
5. Select **Button Press** and press the **OK** button.
6. Select **Off** and press the **OK** button.

Parent topic: [Using the Control Panel](#)

Printer Parts

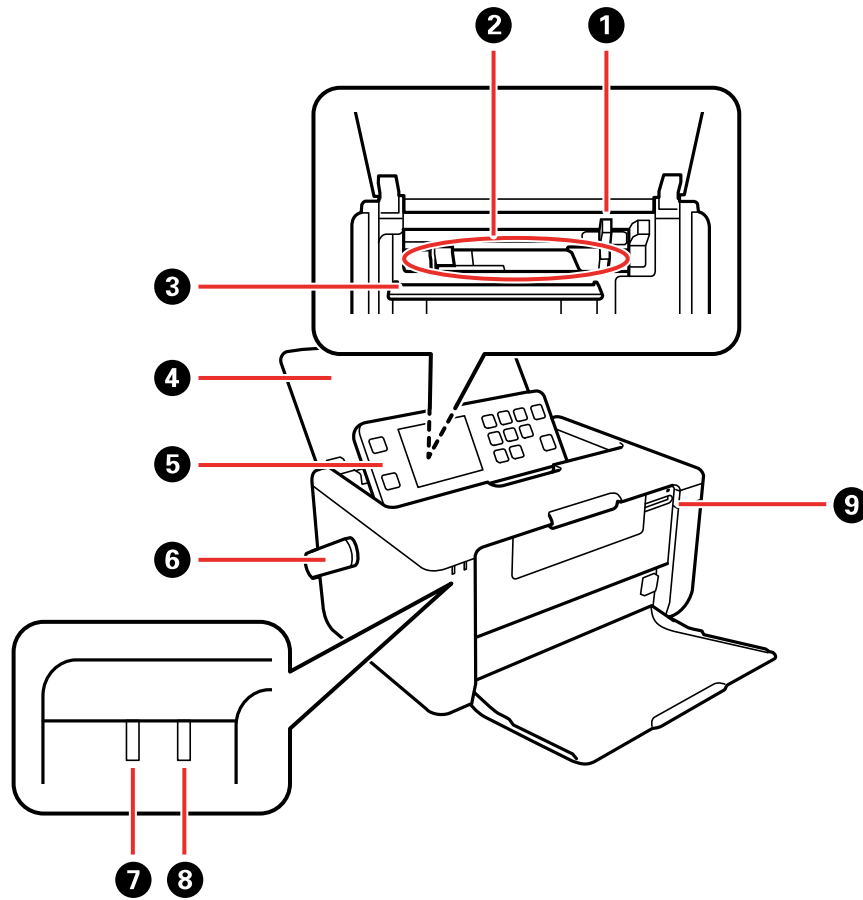

- 1 Edge guide
- 2 Rear paper feed
- 3 Feeder guard
- 4 Rear paper feed cover
- 5 Control panel

- 6 Handle
- 7 The power light
- 8 The battery charging light
- 9 Memory card slot

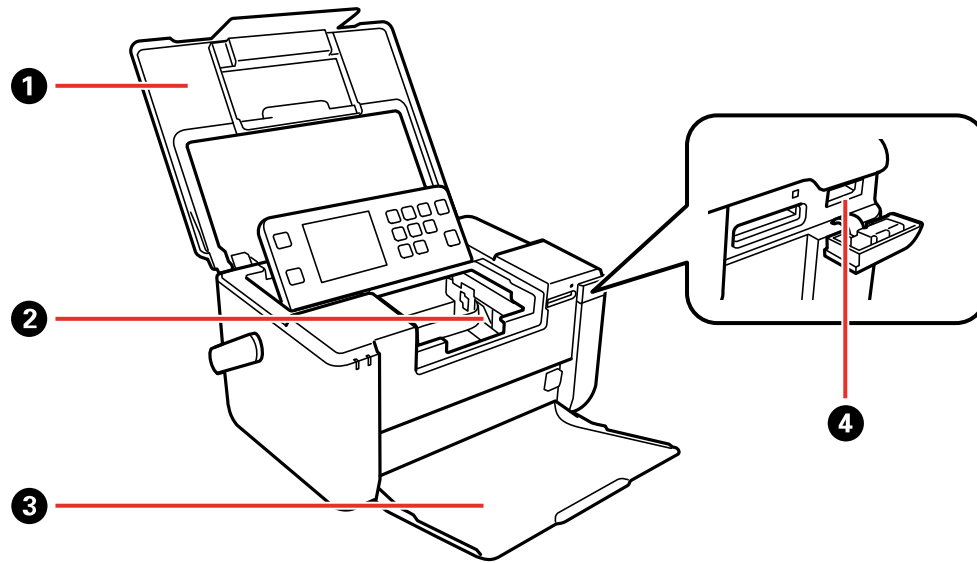

- 1 Printer cover
- 2 Ink cartridge holder
- 3 Output tray

4 External USB port

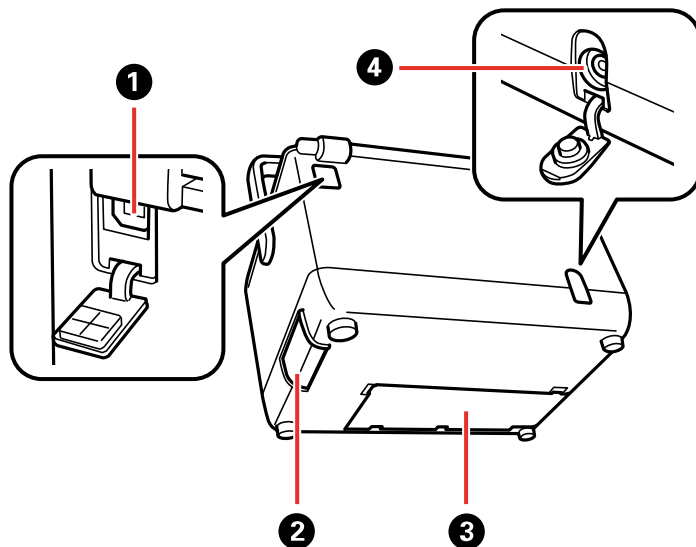

- 1 USB port (for computer)
- 2 Battery cover
- 3 Maintenance box cover
- 4 Power inlet

Parent topic: [Product Basics](#)

Using the Optional Battery

See these sections for instructions on using your product with the optional battery.

[Purchase the Optional Battery](#)

[Installing the Battery](#)

[Charging the Battery Using the AC Adapter](#)

[Battery Safety Instructions](#)

Parent topic: [Product Basics](#)

Purchase the Optional Battery

You can purchase genuine accessories from an Epson authorized reseller. To find the nearest reseller, visit epson.com.jm or call your nearest Epson sales office.

Epson recommends the use of a genuine Epson battery. Epson cannot guarantee the quality or reliability of non-genuine batteries. The use of a non-genuine battery may cause damage that is not covered by Epson's warranties, and under certain circumstances, may cause erratic printer behavior.

[Battery Part Number](#)

Parent topic: [Using the Optional Battery](#)

Battery Part Number

Use this part number to order an optional battery.

Part number	Description
C12C932941	PictureMate battery

Parent topic: [Purchase the Optional Battery](#)

Installing the Battery

Make sure you have an optional battery before you begin.

1. Make sure you installed the ink cartridge and charged the ink system.
2. Turn off the product using the  power button.
3. Disconnect any connected cables.
4. Slide open the battery cover.

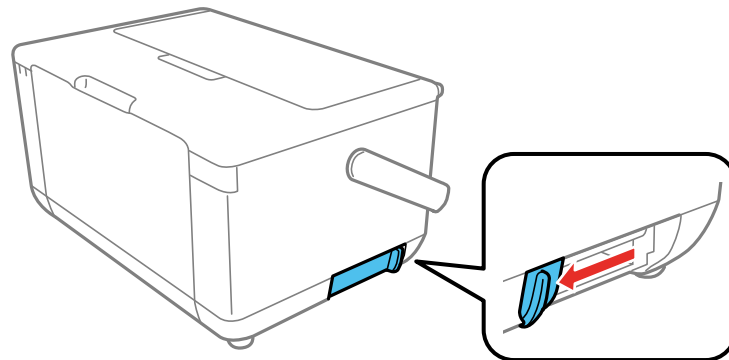

5. Insert the battery all the way into the product until it clicks into place.

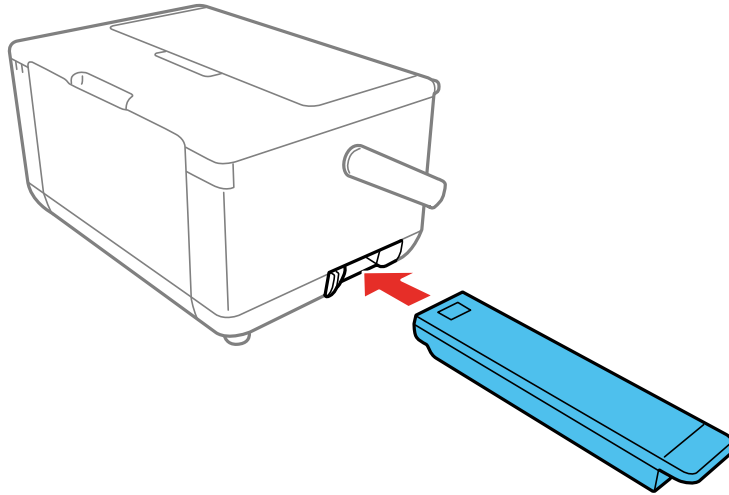

6. Slide the battery cover closed.

Parent topic: [Using the Optional Battery](#)

Charging the Battery Using the AC Adapter

You can charge the battery using the AC adapter.

1. Connect the power cord to the AC adapter, and connect the AC adapter to the printer.

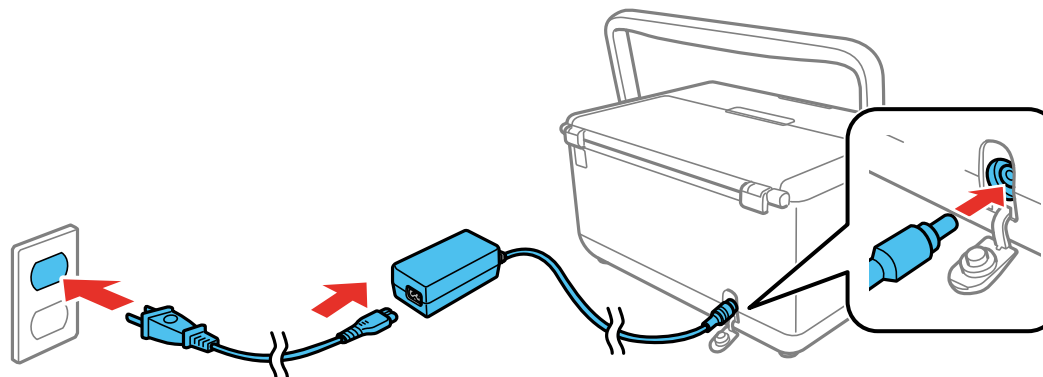

2. Plug the other end of the power cord into an electrical outlet.

Note: The battery charging light turns on while the battery is charging and turns off when charging is complete. It takes approximately 5 hours for the battery to fully charge.

Parent topic: [Using the Optional Battery](#)

Battery Safety Instructions

- If the battery is not fully charged within the specified time, stop charging. Otherwise, the battery could become hot, emit smoke, rupture, or catch fire.
- Do not place the product in a microwave oven or high-pressure container. Otherwise, the battery could become hot, emit smoke, rupture, or catch fire.
- If battery acid gets into your eyes or on your skin, immediately rinse the affected area thoroughly with water and seek medical treatment. Otherwise, permanent eye damage could result.
- If liquid leaks from the product (or the product has a bad odor), move the product away from flammable objects. Otherwise, electrolyte leaked from the battery will catch fire or cause smoke or flame.
- Do not drop or throw the product or subject it to strong shocks. Otherwise, the battery could leak or the protection circuit in the battery could be damaged.
- Do not use the product if it is leaking or damaged in any way.
- Do not leave the product in a vehicle. Otherwise, the battery could overheat.
- Do not handle the battery with wet hands or touch the battery terminals.
- Do not place, store, or charge the battery near water, heat sources, metal objects or in locations subject to shocks, vibrations, condensation, high temperature or humidity.
- Do not incinerate, heat, puncture, strike, step on, or insert an object into any openings in the battery.
- Do not disassemble, modify, or remove the outside case on the battery.
- If the battery overheats, or becomes discolored or deformed, remove the battery from the product and do not use it.
- Do not connect the battery to an electrical outlet or to a car cigarette lighter socket.
- Do not solder any item onto the battery.
- Do not short-circuit the battery or reverse the polarity of the battery terminals.
- If the battery is swallowed, seek medical treatment immediately.

- Use only the battery model specified in this manual with the product.
- Use only the AC adapter model specified in this manual to charge the battery and operate the product.

Parent topic: [Using the Optional Battery](#)

Removing the Handle

If you prefer, you can use the product without the carrying handle.

1. Flip the handle forward, grasp the handle with both hands, and spread it apart to remove the handle.

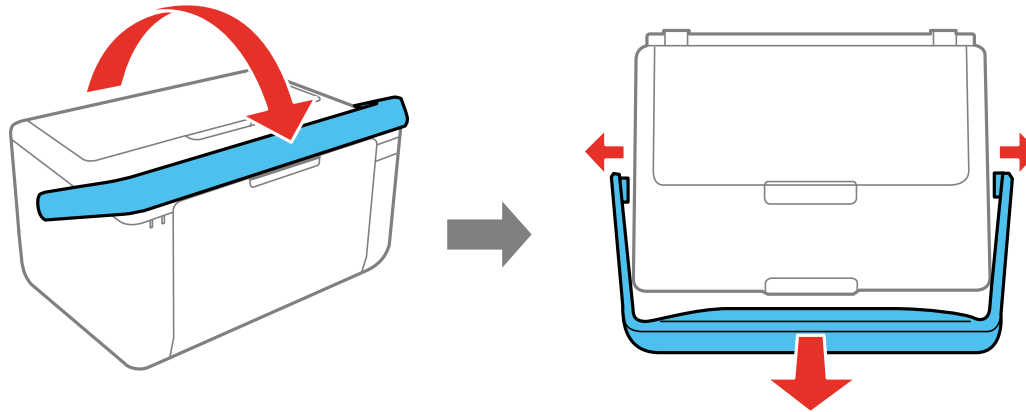

2. Insert the included handle hole caps to protect the interior of your product.

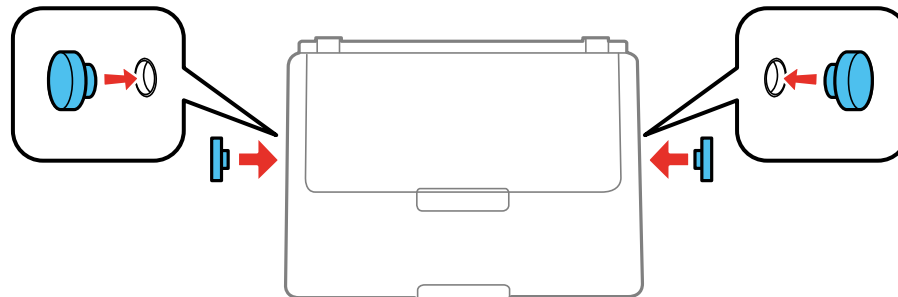

Warning: Keep the handle hole caps out of the reach of children; they are a swallowing hazard.

To reattach the handle, remove the hole caps and insert the handle ends into the handle holes.

Parent topic: [Product Basics](#)

The Power Off and Sleep Timers

The product enters sleep mode or turns off automatically if it is not used for a period of time. You can adjust the time period before power management begins, but increasing the time reduces the product's energy efficiency.



[Changing the Power Off Timer Setting from the Control Panel](#)

[Changing the Sleep Timer Setting from the Control Panel](#)

Parent topic: [Product Basics](#)

Changing the Power Off Timer Setting from the Control Panel



You can use the product's control panel to change the time period before the printer turns off automatically.

1. Press the  home button, if necessary.
2. Press the arrow buttons to select **Setup** and press the **OK** button.
3. Select **Printer Setup** and press the **OK** button.
4. Select **Power Off Timer** and press the **OK** button.
5. Select the time period you want before the product automatically turns off when it is not in use and press the **OK** button.
6. Press the  home button to exit.

Parent topic: [The Power Off and Sleep Timers](#)

Changing the Sleep Timer Setting from the Control Panel

You can use the product's control panel to change the time period before the product enters sleep mode.

1. Press the  home button, if necessary.
2. Press the arrow buttons to select **Setup** and press the **OK** button.
3. Select **Printer Setup** and press the **OK** button.
4. Select **Sleep Timer** and press the **OK** button.
5. Select the time period you want before the product goes to sleep and press the **OK** button.
6. Press the  home button to exit.

Parent topic: [The Power Off and Sleep Timers](#)

Epson Connect Solutions for Smartphones, Tablets, and More

Use your smartphone, tablet, or computer to print documents, photos, emails, and web pages from your home, office, or even across the globe.

[Setting Up Epson Connect Services](#)

[Using Epson Email Print](#)

[Using the Epson Creative Print Mobile App](#)

[Using the Epson iPrint Mobile App](#)

[Using Epson Remote Print](#)

Parent topic: [Product Basics](#)

Related tasks

[Using Google Cloud Print](#)

[Using AirPrint](#)

[Using the Mopria Print Service](#)

[Android Printing Using the Epson Print Enabler](#)

Setting Up Epson Connect Services

If you did not activate your product's email address for use with Epson Connect when you set up your product, you can activate it using the product control panel.

1. Press the  home button, if necessary.
2. Select **Setup** and press the **OK** button.
3. Select **Epson Connect Services** and press the **OK** button.
4. Select **Register/Delete** and press the **OK** button.
5. Select **Yes** and press the **OK** button.
6. Follow the instructions on your screen to activate your product's email address.

Parent topic: [Epson Connect Solutions for Smartphones, Tablets, and More](#)

Using Epson Email Print

With Epson Email Print, you can print from any device that can send email, such as your smartphone, tablet, or laptop. Just activate your product's unique email address. When you want to print, attach a PDF, Microsoft Office document, or photo to an email and send it to your product. Both the email and the attachments will print automatically.

1. Connect your product to your network. See the link below.

2. If you did not already set up Email Print when you installed your product software, see the link below to use your product control panel to activate your unique email address. Or visit epsonconnect.com to learn more about Email Print, create your Epson Connect account, and register your product to the Epson Connect service.
3. Now you are ready to send and print emails to your product's Email Print address.

Note: Go to epsonconnect.com and log into your Epson Connect account to personalize your product's email, adjust print settings, and set up other Epson Connect services.

Parent topic: [Epson Connect Solutions for Smartphones, Tablets, and More](#)

Related tasks

[Setting Up Epson Connect Services](#)

Related topics

[Wi-Fi Networking](#)

Using the Epson Creative Print Mobile App

Use this free Apple and Android app to do the following:

- Access and print your Facebook photos
- Create custom greeting cards and stationery
- Print onto CD/DVDs
- Turn photos into coloring book templates

Note: Not all features may be supported by your product.

1. Connect your product to your wireless network. See the link below.
2. Download Epson Creative Print from the Apple App Store or Google Play.
3. Connect your mobile device to the same wireless network that your product is using.
4. Open Epson Creative Print.

Now you are ready to get creative with your mobile device and your Epson product.

Parent topic: [Epson Connect Solutions for Smartphones, Tablets, and More](#)

Related topics

[Wi-Fi Networking](#)

Using the Epson iPrint Mobile App

Use this free Apple and Android app to print with networked Epson products. Epson iPrint lets you print PDFs, Microsoft Office documents, photos, and web pages from your device or from popular cloud services such as Box, Dropbox, Evernote, Google Drive, or Microsoft OneDrive.

1. Connect your product to your wireless network. See the link below.
2. Visit epson.com/jm/connect to learn more about Epson iPrint and check the compatibility of your mobile device.
3. Download Epson iPrint from the Apple App Store or Google Play.
4. Connect your mobile device to the same wireless network as your product.
5. Open Epson iPrint and select your Epson product.

Now you are ready to print with your mobile device and your Epson product.

Parent topic: [Epson Connect Solutions for Smartphones, Tablets, and More](#)

Related topics

[Wi-Fi Networking](#)

Using Epson Remote Print

With Epson Remote Print software, you can print from your laptop or desktop computer to an Epson Email-enabled product anywhere in the world.

1. Connect your Epson product to your wireless network. See the link below.
2. If you did not already set up an Epson Connect account when you installed your product software, visit epsonconnect.com to create your account and register your product to the Epson Connect service.

Note: Make a note of your product's email address.

3. Visit epsonconnect.com to learn more about Remote Print and how to download the Remote Print Driver software.
4. Download and install the Remote Print software.
5. Enter the email address and optional access key of your Epson product during Remote Print setup.
6. Now you are ready to print remotely. Select the print command in your laptop or desktop computer application and choose the Remote Print option for your Epson product.

Parent topic: [Epson Connect Solutions for Smartphones, Tablets, and More](#)

Related topics

[Wi-Fi Networking](#)

Using Google Cloud Print

With a Google Account, you can print from your Apple or Android device to your Epson product. You can also print from Chromebooks and the Google Chrome browser without drivers or cables.

1. Connect your Epson product to your wireless network. See the link below.
2. Note your product's IP address by checking your network status. See the link below.
3. Connect your computer or your Apple or Android device to the same wireless network as your Epson product.
4. Enter your product's IP address into the address bar of a web browser.
5. Select the **Google Cloud Print Services** option.

Note: If you don't see the **Google Cloud Print Services** option, turn your product off and back on. If the option still doesn't appear, select the **Firmware Update** option and follow the on-screen instructions to update your product.

6. Click **Register**.
7. Select the checkbox to agree to the Usage Advisory and click **Next**.
8. Click **OK** to launch the sign-in page.
A separate browser window opens.
9. Enter your Google Account username and password and click **Sign in**, or, if you don't have an account, click **Sign up for a new Google Account** and follow the on-screen instructions.
10. Click **Finish printer registration** to complete setup and print a test page.

Your product is now linked to your Google Account and can be accessed from any Chromebook, computer, Apple or Android device with Internet access. For more information on using Google Cloud Print and for a list of supported apps, visit the [Google Cloud Print](#) site.

Parent topic: [Product Basics](#)

Related tasks

[Viewing the Network Status](#)

Related topics

[Epson Connect Solutions for Smartphones, Tablets, and More](#)

Using AirPrint

AirPrint enables instant wireless printing from iPhone, iPad, and iPod touch with the latest version of iOS, and Mac with the latest version of OS X or macOS.

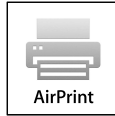

Note: If you disabled paper configuration messages on your product control panel, you cannot use AirPrint. See the link below to enable the messages, if necessary.

1. Load paper in your product.
2. Set up your product for wireless printing. See the link below.
3. Connect your Apple device to the same wireless network that your product is using.
4. Print from your device to your product.

Note: For details, see the AirPrint page on the Apple website.

Parent topic: [Product Basics](#)

Related tasks

[Selecting the Paper Settings - Control Panel](#)

Related topics

[Epson Connect Solutions for Smartphones, Tablets, and More](#)

[Wi-Fi Networking](#)

Using the Mopria Print Service

You can use the Mopria Print Service to print from your Android phone or tablet (Android v4.4 or later) to your Epson product or any Mopria-certified product from other manufacturers. You can download the Mopria Print Service from Google Play.

1. Connect your Epson product to your wireless network. See the link below.
2. On your Android device, download the Mopria Print Service from Google Play.

3. Go to **Settings** on your Android device, select **Printing**, and enable the Mopria Print Service.
4. Connect your Android device to the same wireless network as your product.
5. Now you are ready to print. From an Android application such as Chrome or Gmail, tap the menu icon and select **Print**. Then select **All printers**, select your Epson product, adjust your print settings, and print.

Parent topic: [Product Basics](#)

Related topics

[Epson Connect Solutions for Smartphones, Tablets, and More](#)
[Wi-Fi Networking](#)

Android Printing Using the Epson Print Enabler

You can wirelessly print your documents, emails, photos, and web pages right from your Android phone or tablet (Android v4.4 or later). With a few taps, your Android device will discover your nearby Epson product and print.

1. Connect your Epson product to your wireless network. See the link below.
2. On your Android device, download the Epson Print Enabler plug-in from Google Play.
3. Go to **Settings** on your Android device, select **Printing**, and enable the Epson plug-in.
4. Connect your Android device to the same wireless network as your product.
5. Now you are ready to print. From an Android application such as Chrome or Gmail, tap the menu icon and print whatever is on the screen.

Note: If you do not see your product, tap **All Printers** and select your product.

Parent topic: [Product Basics](#)

Related topics

[Epson Connect Solutions for Smartphones, Tablets, and More](#)
[Wi-Fi Networking](#)

Wi-Fi Networking

See these sections to use your product on a Wi-Fi network.

[Wi-Fi Infrastructure Mode Setup](#)

[Wi-Fi Direct Mode Setup](#)

[Wi-Fi Protected Setup \(WPS\)](#)

[Viewing the Network Status](#)

[Printing a Network Connection Report](#)

[Changing or Updating Network Connections](#)

Wi-Fi Infrastructure Mode Setup

You can set up your product to communicate with your computer using a wireless router or access point. The wireless router or access point can be connected to your computer over a wireless or wired network.

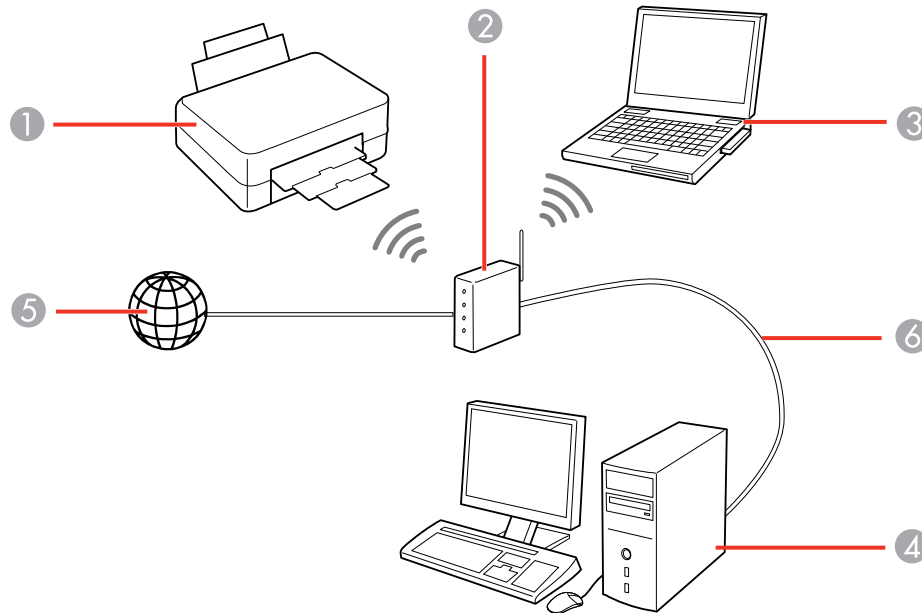

1 Epson product

- 2 Wireless router or access point
- 3 Computer with a wireless interface
- 4 Computer
- 5 Internet
- 6 Ethernet cable (used only for wired connection to the wireless router or access point)

Selecting Wireless Network Settings from the Control Panel

Parent topic: [Wi-Fi Networking](#)

Selecting Wireless Network Settings from the Control Panel

You can select or change wireless network settings using your product control panel.

To install your product on a wireless network, follow the instructions on the *Start Here* sheet and install the necessary software. The installer program guides you through network setup.

1. Press the  home button, if necessary.
2. Press the arrow buttons to select **Wi-Fi Setup** and press the **OK** button.
3. Press the **OK** button to select **Wi-Fi (Recommended)**.
4. Press the **OK** button again to proceed.
5. Select **Wi-Fi Setup Wizard** and press the **OK** button.
6. Press the arrow buttons to select the name of your wireless network and press the **OK** button. If you do not see your wireless network's name, you can enter it manually.

Note: To enter the wireless network name manually, select **Other Networks** and press the **OK** button. Enter your network name as described in the next step.

7. If you see the following screen, enter your wireless password (or network name and then password).

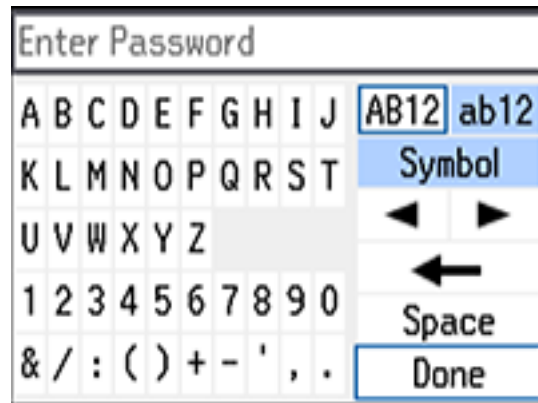

- Press the arrow buttons to highlight a character or a function button displayed on the keypad. Then press the **OK** button to select it.
 - To change the case of letters or select symbols, select **AB12** (uppercase), **ab12** (lowercase), or **Symbol** and press the **OK** button.
 - To enter a space, select **Space** and press the **OK** button.
 - To delete characters, select the back arrow and press the **OK** button.
 - When you finish entering characters, select **Done** and press the **OK** button.
8. Press the **OK** button to confirm Wi-Fi settings.
9. If you want to print a network status report, press the \diamond start button. (Otherwise, press the **OK** button.)

Your product should now be connected to the network.

Note: The Wi-Fi icon is displayed in the upper left area on the LCD screen and indicates your wireless connection status. If the product is not connected to the network, you may have selected the wrong network name or entered the password incorrectly. Repeat these steps to try again.

Parent topic: [Wi-Fi Infrastructure Mode Setup](#)

Related tasks

[Viewing the Icon List](#)

Wi-Fi Direct Mode Setup

You can set up your product to communicate directly with your computer or another device without requiring a wireless router or access point.

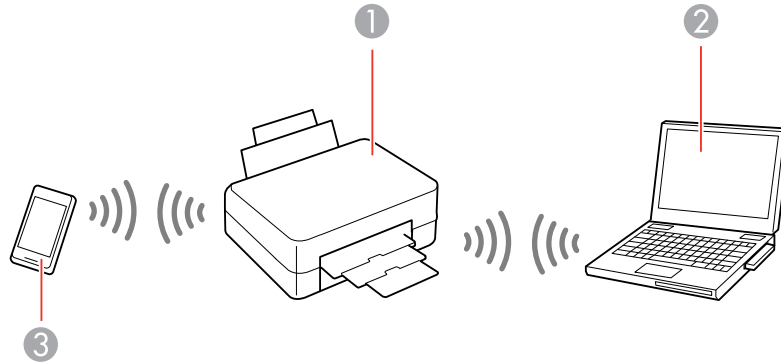

- 1 Epson product
- 2 Computer with a wireless interface
- 3 Other wireless device

You can select one of these modes to communicate with your computer or device:

Access point mode

The product itself acts as the network access point for up to 4 devices. When operating in this mode, your product displays an **AP** connection symbol on the LCD screen.

Peer-to-peer mode

The product communicates one-to-one with another Wi-Fi Direct capable device. When operating in this mode, your product displays a **Direct** or **D** connection symbol on the LCD screen.

To disconnect a peer-to-peer mode connection, release the connection to your product from your computer or other device.

To enable peer-to-peer mode, you must select it from the Web Config Utility, under **WiFi/Network Settings > Services > Wi-Fi Direct**.

[Enabling Wi-Fi Direct Mode](#)

Parent topic: [Wi-Fi Networking](#)

Enabling Wi-Fi Direct Mode

You can enable Wi-Fi Direct mode to allow direct communication between your product and computer or other devices without a wireless router or access point.

1. Press the  home button, if necessary.
2. Press the arrow buttons to select **Wi-Fi Setup** and press the **OK** button.
3. Press the up or down arrow button to select **Wi-Fi Direct** and press the **OK** button.
4. Press the **OK** button to confirm your selection.
5. Scroll down to view the Wi-Fi network name (SSID) and password.
6. Use your computer or wireless device to select the Wi-Fi network name (SSID) displayed on the LCD screen, then enter the password shown.
7. Press the **OK** button to exit.

Parent topic: [Wi-Fi Direct Mode Setup](#)

Wi-Fi Protected Setup (WPS)

If your network uses a WPS-enabled wireless router or access point, you can quickly connect your product to the network using Wi-Fi Protected Setup (WPS).

Note: To check if your router is WPS-enabled, look for a button labeled **WPS** on your router or access point. If there is no hardware button, there may be a virtual WPS button in the software for the device. Check your network product documentation for details.

[Using WPS to Connect to a Network](#)

Parent topic: [Wi-Fi Networking](#)

Using WPS to Connect to a Network

If you have a WPS-enabled wireless router or access point, you can use Wi-Fi Protected Setup (WPS) to connect your product to the network.

1. On the product, press the  home button, if necessary.
2. Press the arrow buttons to select **Wi-Fi Setup** and press the **OK** button.
3. Press the **OK** button to select **Wi-Fi (Recommended)**.
4. Press the **OK** button again to proceed.
5. Select **Push Button Setup (WPS)** and press the **OK** button.

6. Follow the instructions on the LCD screen to complete WPS setup.
Your product should now be connected to the network.

Note: The Wi-Fi icon is displayed in the upper left area on the LCD screen and indicates your wireless connection status. If the product is not connected to the network, repeat these steps to try again.

Parent topic: [Wi-Fi Protected Setup \(WPS\)](#)

Related tasks

[Viewing the Icon List](#)

Viewing the Network Status



You can view the product's network status to help you determine the causes of any problems you may have using your product on a network.

1. Press the  home button, if necessary.
2. Press the arrow buttons to select **Setup** and press the **OK** button.
3. Select **Network Settings** and press the **OK** button.
4. Select **Network Status** and press the **OK** button.
5. Press the up or down arrow button to view the product's network status. To view additional network details, press the left or right arrow button and select one of the options shown.

Parent topic: [Wi-Fi Networking](#)

Printing a Network Connection Report

You can print a network connection report to check the connection status between the product and your network.

1. Load paper in the product.
2. Press the  home button, if necessary.
3. Press the arrow buttons to select **Setup** and press the **OK** button.
4. Select **Network Settings** and press the **OK** button.
5. Select **Connection Check** and press the **OK** button.
6. Press the  start button to print the report.

If an error code is shown on the report, you can check for solutions by visiting the website listed on the report.

Parent topic: [Wi-Fi Networking](#)

Changing or Updating Network Connections

See these sections to change or update how your product connects to a network.

[Accessing the Web Config Utility](#)

[Changing a USB Connection to a Wi-Fi Connection](#)

[Connecting to a New Wi-Fi Router](#)

[Disabling Wi-Fi Features](#)

Parent topic: [Wi-Fi Networking](#)

Accessing the Web Config Utility

You can select your product's network settings and confirm its operating status using a web browser. You do this by accessing your product's built-in Web Config utility from a computer or other device that is connected to the same network as your product.

1. Check your network status.
2. Note your product's IP address.
3. On a computer or other device connected to the same network as your product, open a web browser.
4. Enter your product's IP address into the address bar.

You see the available Web Config utility options.

Parent topic: [Changing or Updating Network Connections](#)

Related tasks

[Viewing the Network Status](#)

Changing a USB Connection to a Wi-Fi Connection

If you have already connected your product to your computer using a USB connection, you can change to a Wi-Fi connection.

1. Disconnect the USB cable from your product.
2. Uninstall your product software.

3. Download and install your product software from the Epson website using the instructions on the *Start Here* sheet.

Parent topic: [Changing or Updating Network Connections](#)

Related concepts

[Uninstall Your Product Software](#)

Connecting to a New Wi-Fi Router

If you change the wireless router you have been using on your network, you need to update your product's Wi-Fi connection to the new router.

Note: If you switch to a 5 GHz wireless router, set the router to operate in dual band (2.4 GHz and 5 GHz) mode. See your router documentation for instructions.

1. Do one of the following:
 - **Windows:** Uninstall your product software.
 - **Mac:** Go to the next step.
2. Download and install your product software from the Epson website using the instructions on the *Start Here* sheet.

Parent topic: [Changing or Updating Network Connections](#)

Related concepts

[Uninstall Your Product Software](#)

Disabling Wi-Fi Features

You may need to disable your product's Wi-Fi features if you change your network connection type or need to solve a problem with your network connection.

Note: Before disabling Wi-Fi features, make a note of your product's SSID (network name) and password, and any network settings selected for the Epson Connect services you may use.

1. Press the  home button, if necessary.
2. Press the arrow buttons to select **Setup** and press the **OK** button.
3. Select **Network Settings** and press the **OK** button.
4. Select **Wi-Fi Setup** and press the **OK** button.

5. Select **Disable Wi-Fi** and press the **OK** button.
6. Select **Yes** and press the **OK** button to disable Wi-Fi.

Parent topic: [Changing or Updating Network Connections](#)

Related tasks

[Viewing the Network Status](#)

Related topics

[Epson Connect Solutions for Smartphones, Tablets, and More](#)

Loading Paper

Before you print, load paper for the type of printing you will do.

[Loading Paper in the Paper Feed Slot](#)

[Paper Loading Capacity](#)

[Available Epson Papers](#)

[Borderless Paper Type Compatibility](#)

[Paper or Media Type Settings - Product Software](#)

[Selecting the Paper Settings - Control Panel](#)

Loading Paper in the Paper Feed Slot

You can print photos on a variety of paper types and sizes up to: 5 × 7 inches (127 × 178 mm)

1. Move the handle behind the product, then open the rear paper feed cover.

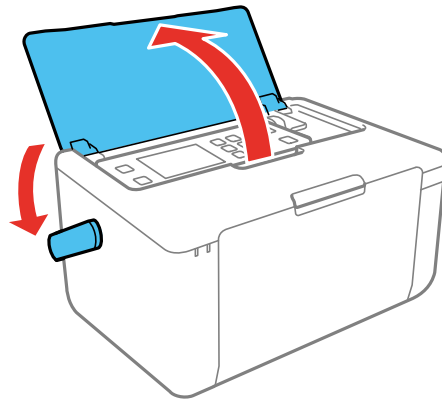

2. Raise the control panel, then open the feeder guard.

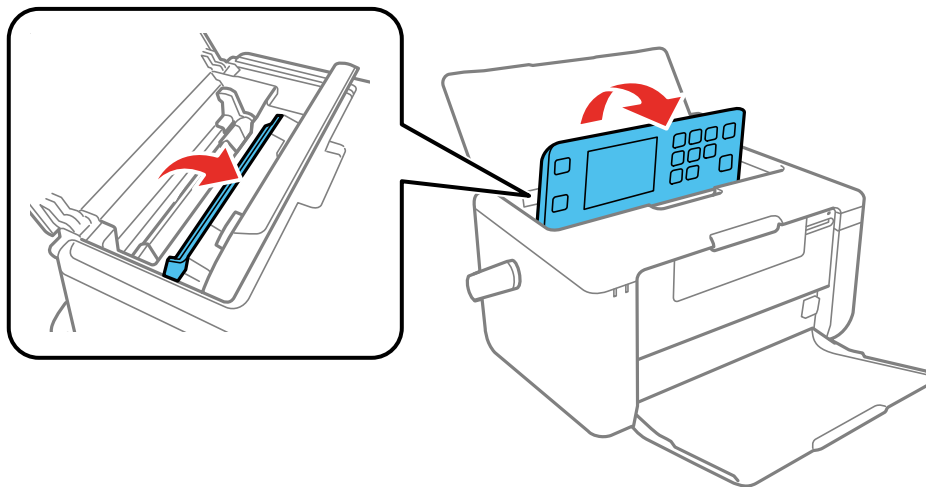

3. Slide the edge guide to the right.

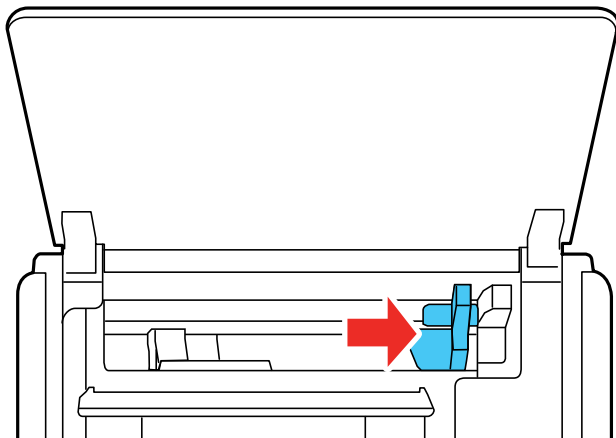

4. Load paper, glossy or printable side up and short edge first, against the left side of the paper feed slot.

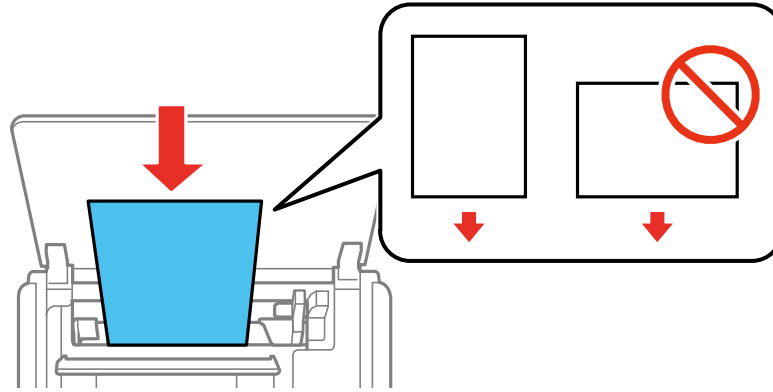

Note: To load envelopes, insert the envelopes printable side up and flap edge left.

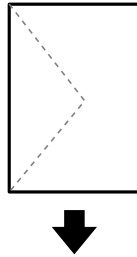

5. Slide the edge guide against the paper, then close the feeder guard.

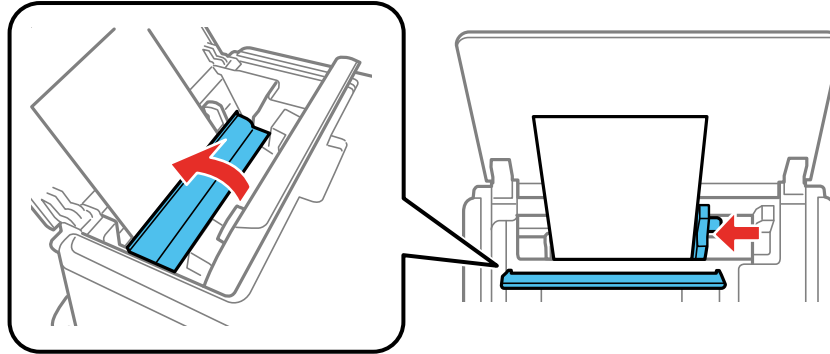

6. Do one of the following to select the size and type of paper you just loaded on the product LCD screen:
 - To use the existing settings, press the **OK** button.
 - To change the settings, press the up or down arrow button to select **Change** and press the **OK** button. Select the paper size and press the **OK** button, select the paper type and press the **OK** button, then press the **OK** button again to confirm the settings.

Note: To prevent the paper setup screen from appearing automatically when you load paper, turn off the **Paper Configuration** setting in the Setup menu. (This will also disable AirPrint.)

7. Open the output tray.

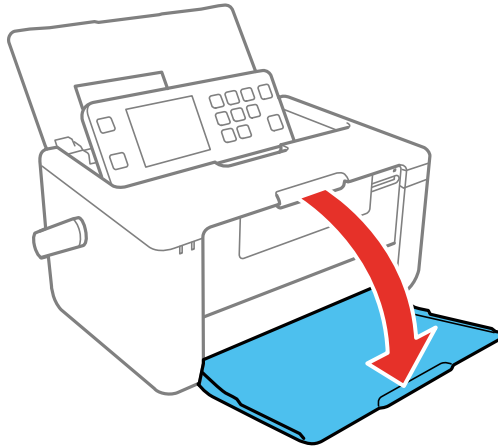

Always follow these paper loading guidelines:

- Load only the recommended number of sheets.
- Load paper short edge first, no matter which way your document faces.
- Do not load paper above the arrow mark inside the edge guide.
- Do not load envelopes that are curled, folded, or too thin, or that have plastic windows.
- Check the paper package for any additional loading instructions.

Parent topic: [Loading Paper](#)

Related references

[Paper Type Settings - Control Panel](#)

[Paper Loading Capacity](#)

Paper Loading Capacity

Paper type	Paper size	Load up to this many sheets
Plain paper*	A5 (5.8 × 8.2 inches [148 × 210 mm])	Up to the arrow mark on the edge guide or approximately 50 sheets
	A6 (4.1 × 5.8 inches [105 × 148 mm])	
Epson Photo Paper Glossy	4 × 6 inches (102 × 152 mm)	20 sheets
Epson Premium Photo Paper Glossy	4 × 6 inches (102 × 152 mm)	
	5 × 7 inches (127 × 178 mm)	
Epson Premium Photo Paper Semi-gloss	4 × 6 inches (102 × 152 mm)	
Epson Ultra Premium Photo Paper Glossy	4 × 6 inches (102 × 152 mm)	
	5 × 7 inches (127 × 178 mm)	
Envelopes	No. 10 (4.1 × 9.5 inches [105 × 241 mm])	1 envelope

* You can load up to 20 sheets for manual 2-sided print jobs.

Parent topic: [Loading Paper](#)

Available Epson Papers

You can purchase genuine Epson ink and paper from an Epson authorized reseller. To find the nearest reseller, visit epson.com.jm or call your nearest Epson sales office.

Paper type	Size	Part number	Sheet count
Epson Photo Paper Glossy	4 × 6 inches (102 × 152 mm)	S041809-20	20
		S041809	50
		S042038	100
Epson Premium Photo Paper Glossy	4 × 6 inches (102 × 152 mm)	S041808	40
		S041727	100
	5 × 7 inches (127 × 178 mm)	S041464	20

Paper type	Size	Part number	Sheet count
Epson Ultra Premium Photo Paper Glossy	4 × 6 inches (102 × 152 mm)	S042181	60
		S042174	100
	5 × 7 inches (127 × 178 mm)	S041945	20
Epson Premium Photo Paper Semi-gloss	4 × 6 inches (102 × 152 mm)	S041982	40

Note: Paper/media availability varies by country.

Parent topic: [Loading Paper](#)

Borderless Paper Type Compatibility

You can print borderless photos on compatible paper types in compatible sizes:

Borderless Paper Types

- Epson Photo Paper Glossy
- Epson Premium Photo Paper Glossy
- Epson Ultra Premium Photo Paper Glossy
- Epson Premium Photo Paper Semi-gloss

Borderless Paper Sizes

- 4 × 6 inches (102 × 152 mm)
- 5 × 7 inches (127 × 178 mm)

Parent topic: [Loading Paper](#)

Paper or Media Type Settings - Product Software



For this paper	Select this Paper Type or Media Type setting
Plain paper	Plain Paper
Epson Ultra Premium Photo Paper Glossy	Ultra Premium Photo Paper Glossy
Epson Premium Photo Paper Glossy	Premium Photo Paper Glossy

For this paper	Select this Paper Type or Media Type setting
Epson Photo Paper Glossy	Photo Paper Glossy
Epson Premium Photo Paper Semi-gloss	Premium Photo Paper Semi-Gloss
Envelope	Envelope

Parent topic: [Loading Paper](#)

Selecting the Paper Settings - Control Panel

You can change the default paper settings using the control panel on the product.

1. Press the  home button, if necessary.
2. Select **Setup** > **Printer Setup** > **Paper Source Settings**.
3. Select the following options as necessary:
 - **Paper Setup**: Changes the default paper size and paper type settings.
 - **Paper Setting Alert**: Controls whether or not an alert appears when a print job's paper settings are different from the product's default paper settings.
 - **Paper Configuration**: Controls whether or not the paper settings selection screen appears after you load paper.
4. Press the  home button to exit.

[Paper Type Settings - Control Panel](#)

Parent topic: [Loading Paper](#)

Paper Type Settings - Control Panel

For this paper	Select this Paper Type setting
Plain paper	Plain Paper
Epson Ultra Premium Photo Paper Glossy	Ultra Glossy
Epson Premium Photo Paper Glossy	Prem. Glossy
Epson Photo Paper Glossy	Glossy
Epson Premium Photo Paper Semi-gloss	Prem. Semi-Gloss
Envelope	Envelope

Parent topic: [Selecting the Paper Settings - Control Panel](#)

Printing from a Computer

Before printing from your computer, make sure you have set up your product and installed its software as described on the *Start Here* sheet.

Note: If you have an Internet connection, it is a good idea to check for updates to your product software on Epson's support website. If you see a Software Update screen, select **Enable automatic checking** and click **OK**. The update scans your system to see if you have the latest product software. Follow the on-screen instructions.

[Printing with Windows](#)

[Printing on a Mac](#)

[Printing From a Chromebook](#)

[Cancelling Printing Using a Product Button](#)

Printing with Windows

You can print with your product using any Windows application, as described in these sections.

[Selecting Basic Print Settings - Windows](#)

[Selecting Double-sided Printing Settings - Windows](#)

[Selecting Additional Layout and Print Options - Windows](#)

[Selecting a Printing Preset - Windows](#)

[Selecting Extended Settings - Windows](#)

[Printing Your Document or Photo - Windows](#)

[Selecting Default Print Settings - Windows](#)

[Changing Automatic Update Options](#)

Parent topic: [Printing from a Computer](#)

Selecting Basic Print Settings - Windows

Select the basic settings for the document or photo you want to print.

1. Open a photo or document for printing.
2. Select the print command in your application.

Note: You may need to select a print icon on your screen, the **Print** option in the **File** menu, or another command. See your application's help utility for details.

3. If necessary, select your product name as the printer you want to use.

Note: You may also need to select **Properties** or **Preferences** to view your print settings.

You see the Main tab of your printer settings window:

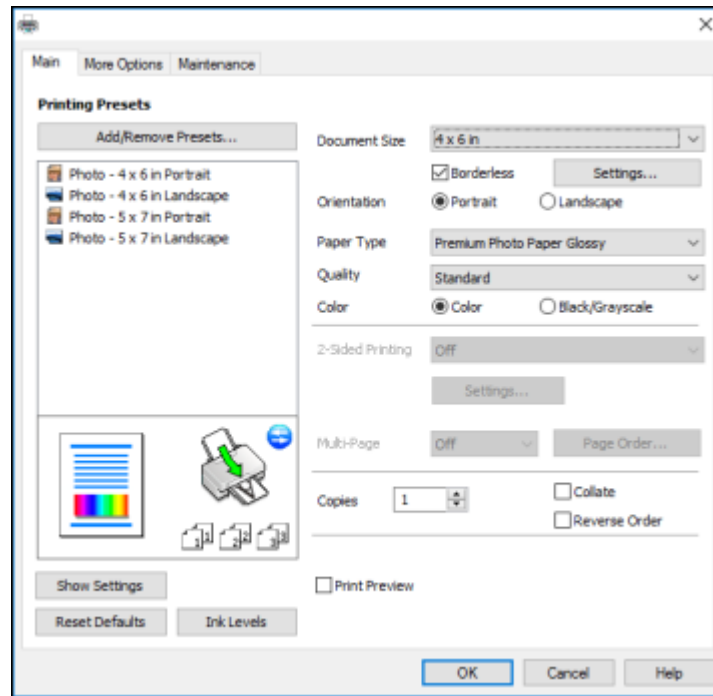

4. Select the size of the paper you loaded as the **Document Size** setting.

Note: You can also select the **User-Defined** setting to create a custom paper size, but you cannot use the **Borderless** setting.

5. If you are printing a borderless photo, select **Borderless**. You can click **Settings** to access additional options for borderless printing.

Note: You must select a compatible borderless paper type and size to print without borders. Check the borderless paper compatibility list for details.

6. Select the orientation of your document.

Note: If you are printing an envelope, select **Landscape**.

7. Select the type of paper you loaded as the **Paper Type** setting.

Note: The setting may not exactly match the name of your paper. Check the paper type settings list for details.

8. Select the **Quality** setting that matches the print quality you want to use.

9. Select a Color option:

- To print a color document or photo, select the **Color** setting.
- To print text and graphics in black or shades of gray, select the **Black/Grayscale** setting.

10. To print on both sides of the paper, select a **2-Sided Printing** option.

11. To print multiple pages on one sheet of paper, or print one image on multiple sheets of paper, select one of the settings in the **Multi-Page** menu and select the printing options you want.

12. To print multiple copies and arrange their print order, select the **Copies** options.

13. To preview your job before printing, select **Print Preview**.

[Print Quality Options - Windows](#)

[Multi-Page Printing Options - Windows](#)

Parent topic: [Printing with Windows](#)

Related references

[Borderless Paper Type Compatibility](#)

[Paper or Media Type Settings - Product Software](#)

Print Quality Options - Windows

You can select any of the available Quality options to fine-tune the quality of your print. Some settings may be unavailable, depending on the paper type setting you have chosen.

Standard

For everyday text and image printing.

High

For text and graphics with high print quality.

Parent topic: [Selecting Basic Print Settings - Windows](#)

Multi-Page Printing Options - Windows

You can select any of the available options in the Multi-Page menu to set up your multi-page print job.

2-Up and 4-Up

Prints 2 or 4 pages on one sheet of paper. Click the **Page Order** button to select page layout and border options.

2×1 Poster, 2×2 Poster, 3×3 Poster, 4×4 Poster

Prints one image on multiple sheets of paper to create a larger poster. Click the **Settings** button to select image layout and guideline options.

Parent topic: [Selecting Basic Print Settings - Windows](#)

Selecting Double-sided Printing Settings - Windows

You can print on both sides of the paper by selecting one of the **2-Sided Printing** options on the Main tab.

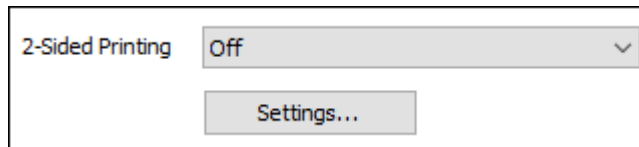

Note: You will need to print one side and flip the paper over manually to print the other side.

Note: Some options may be pre-selected or unavailable, depending on other settings you have chosen or if you are accessing the product over a network.

1. Select one of the following options for **2-Sided Printing**:
 - **Manual (Long-edge binding)** to print your double-sided print job by printing one side and prompting you to flip the paper over on the long edge to print the other side.
 - **Manual (Short-edge binding)** to print your double-sided print job by printing one side and prompting you to flip the paper over on the short edge to print the other side.
2. Click the **Settings** button.

You see a window like this:

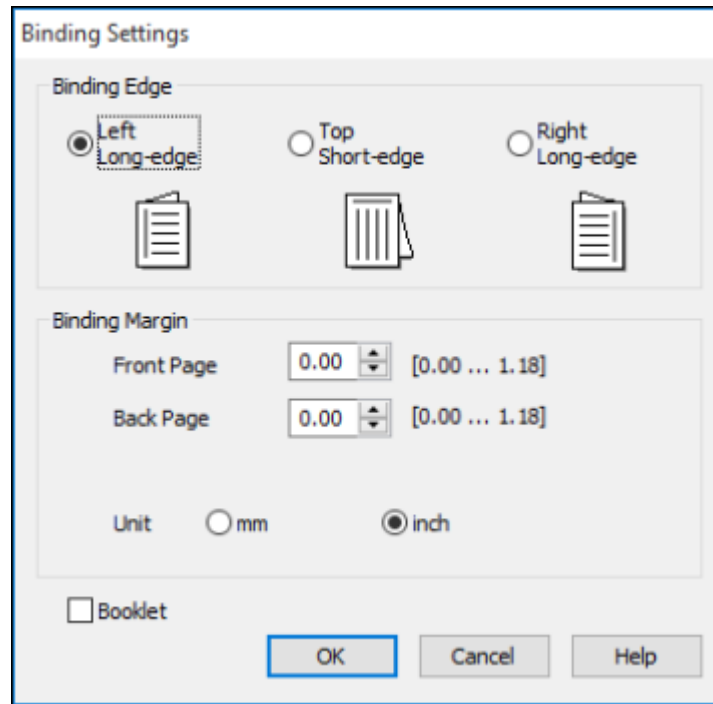

3. Select the double-sided printing options you want to use.
4. Click **OK** to return to the Main tab.
5. Print a test copy of your double-sided document to test the selected settings.
6. Follow any instructions displayed on the screen during printing.

Note: The surface of the paper may smear during double-sided printing. Make sure the ink has dried before reloading the paper.

[Double-sided Printing Options - Windows](#)

Parent topic: [Printing with Windows](#)

Double-sided Printing Options - Windows

You can select any of the available options on the 2-Sided Printing Settings window to set up your double-sided print job.

Binding Edge Options

Select a setting that orients double-sided print binding in the desired direction.

Binding Margin Options

Select options that define a wider margin to allow for binding.

Booklet

Select the **Booklet** checkbox to print double-sided pages as a booklet.

Parent topic: [Selecting Double-sided Printing Settings - Windows](#)

Selecting Additional Layout and Print Options - Windows

You can select a variety of additional layout and printing options for your document or photo on the More Options tab.

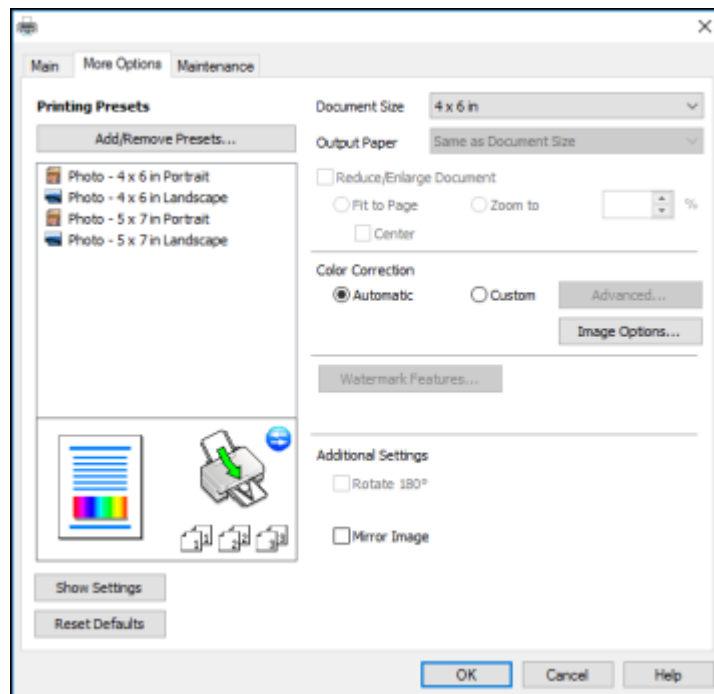

1. To change the size of your printed document or photo, select the **Reduce/Enlarge Document** checkbox and select one of these sizing options:
 - Select the **Fit to Page** option to size your image to fit the paper you loaded. Select the size of your document or photo as the **Document Size** setting, and the size of your paper as the **Output Paper** setting. If you want to center your image on the paper, select the **Center** option.
 - Select the **Zoom to** option to reduce or enlarge your document or photo by a specific percentage. Select the percentage in the % menu.
2. Select one of the following Color Correction options:
 - Select **Automatic** to automatically adjust the sharpness, brightness, contrast, and color saturation for your image.
 - Select **Custom** and click the **Advanced** button to manually adjust the color correction settings or turn off color management in your printer software.
 - Select **Image Options** to access additional settings for improving printed images.

Note: You can also select **Color Universal Print** settings.
3. To add a visible watermark to your printout, click the **Watermark Features** button.

Note: Click the **Add/Delete** button to create your own watermark, and click the **Settings** button to customize the watermark.
4. Select any of the Additional Settings options to customize your print.

[Custom Color Correction Options - Windows](#)

[Image Options and Additional Settings - Windows](#)

Parent topic: [Printing with Windows](#)

Custom Color Correction Options - Windows

You can select any of the available options in the Color Correction window to customize the image colors for your print job.

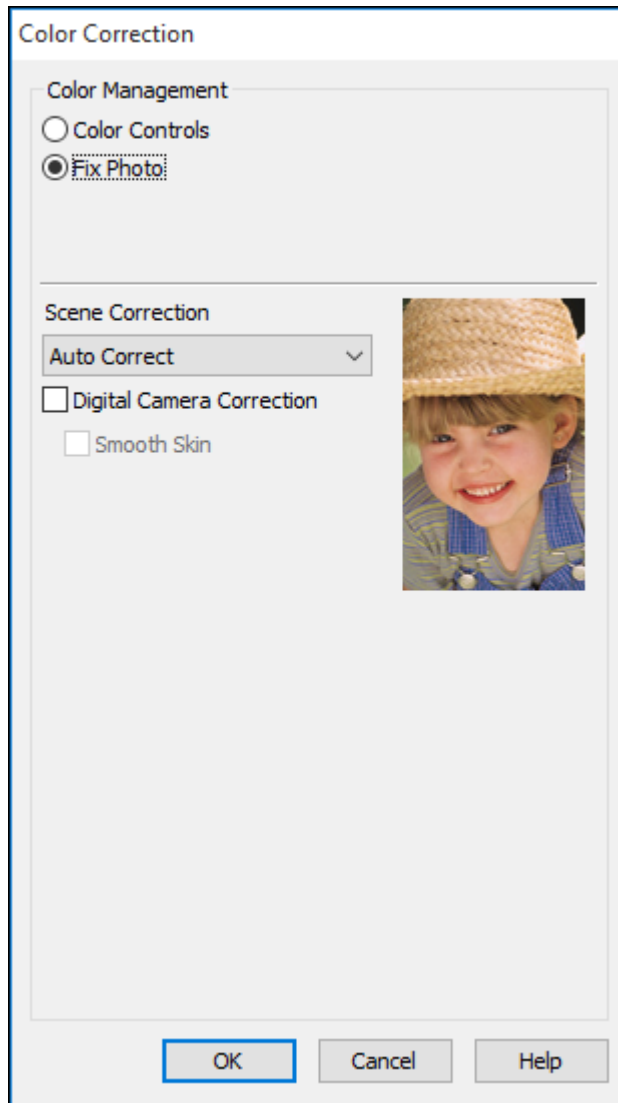

Color Controls

Lets you select a **Color Mode** setting, individual settings for **Brightness**, **Contrast**, **Saturation**, and **Density**, and individual color tones. Depending on the selected color mode, you can also adjust the midtone density using the **Gamma** setting.

Fix Photo

Improves the color, contrast, and sharpness of flawed photos.

Note: Fix Photo uses a sophisticated face recognition technology to optimize photos that include faces. For this to work, both eyes and the nose must be visible in the subject's face. If your photo includes a face with an intentional color cast, such as a statue, you may want to turn off **Fix Photo** to retain the special color effects.

Parent topic: [Selecting Additional Layout and Print Options - Windows](#)

Image Options and Additional Settings - Windows

You can select any of the Image Options and Additional Settings to customize your print. Some options may be pre-selected or unavailable, depending on other settings you have chosen.

Image Options

Emphasize Text

Adjusts the weight of printed text to increase readability.

Emphasize Thin Lines

Adjusts the weight of printed lines to increase visibility.

Edge Smoothing

Smooths jagged edges in low-resolution images such as screen captures or images from the Web.

Fix Red-Eye

Reduces or removes red-eye in photos.

Enhancement Options

Specifies Color Universal Print enhancement settings for text, graphics, and images.

Additional Settings Options

Rotate 180°

Prints the image rotated 180° from its original orientation.

Mirror Image

Flips the printed image left to right.

Parent topic: [Selecting Additional Layout and Print Options - Windows](#)

Selecting a Printing Preset - Windows

For quick access to common groups of print settings, you can select a printing preset on the Main or More Options tab.

Note: You can create your own preset by clicking the **Add/Remove Presets** button.

1. Click the **Main** or **More Options** tab.

You see the available **Printing Presets** on the left:

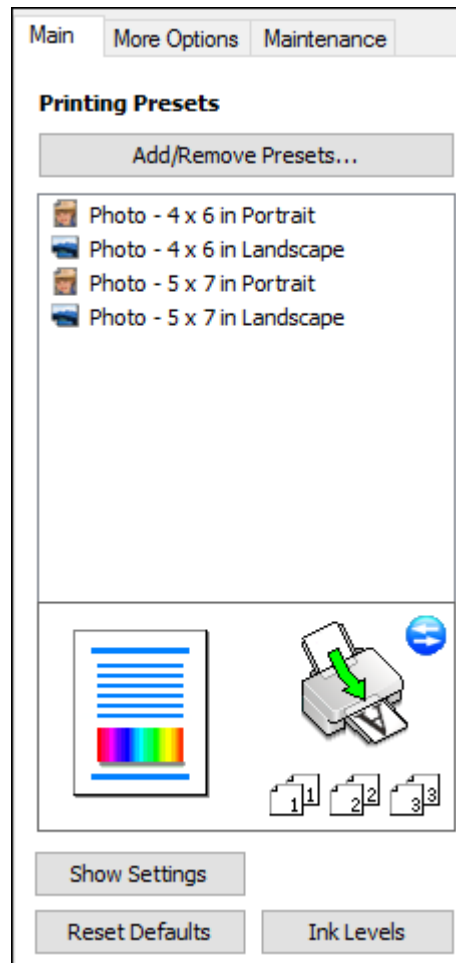

2. Place your cursor over one of the **Printing Presets** to view its list of settings.
3. Click on a preset to change its settings, or use any of the available options on the screen to control your printing presets.
4. To choose a preset for printing, select it.
5. Click **OK**.

Parent topic: [Printing with Windows](#)

Selecting Extended Settings - Windows

You can select additional settings that apply to all the print jobs you send to your product.

1. Access the Windows Desktop and right-click the product icon in the Windows taskbar.
2. Select **Printer Settings**.
3. Click the **Maintenance** tab.

You see the maintenance options:

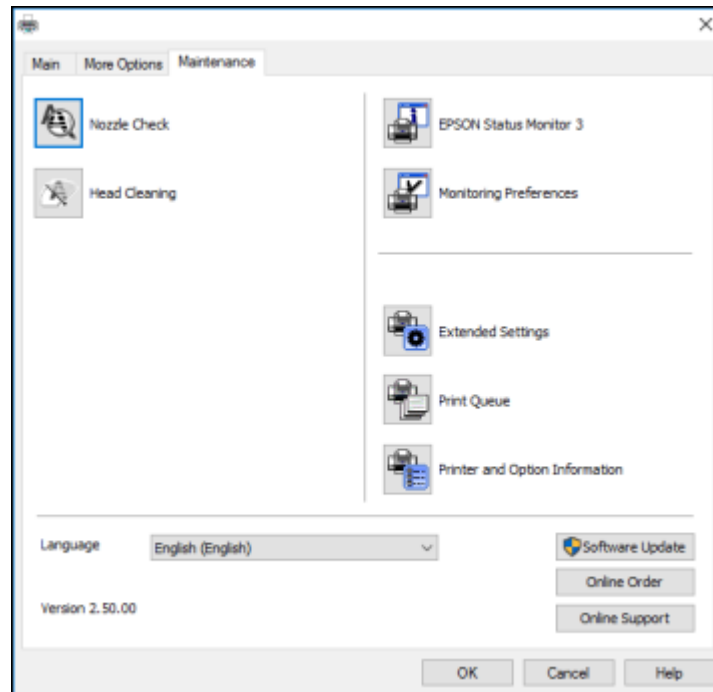

4. Click the **Extended Settings** button.

You see this window:

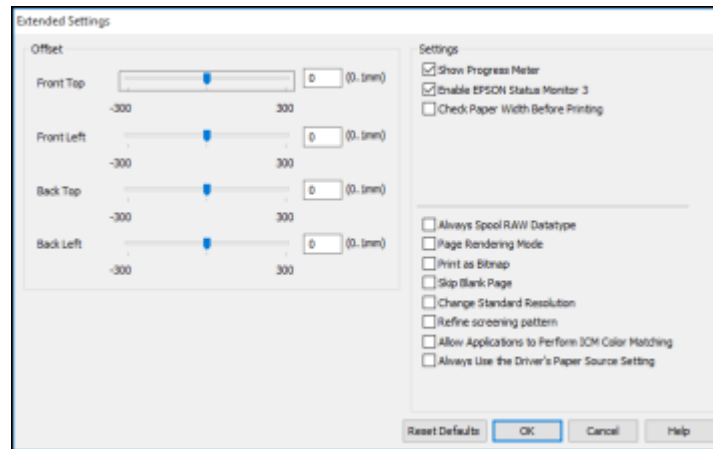

5. Select any of the extended settings to customize your print.
6. Click **OK** to close the Extended Settings window.
7. Click **OK** to close the printer software window.

[Extended Settings - Windows](#)

Parent topic: [Printing with Windows](#)

Extended Settings - Windows

You can select from these settings on the Extended Settings window.

Show Progress Meter

Displays the progress of print jobs as they are being printed.

Enable EPSON Status Monitor 3

Enables product monitoring for ink and paper supplies and other issues.

Check Paper Width Before Printing

Prevents printing beyond the edges of the paper if the paper size setting is incorrect; may reduce print speed.

Always Spool RAW Datatype

Increases print speed and may solve other printing problems.

Page Rendering Mode

Increases print speed when printing is extremely slow or the print head stops during printing.

Print as Bitmap

Increases print speed when printing is extremely slow or the print head stops during printing, and other settings do not help.

Skip Blank Page

Ensures that your product does not print pages that contain no text or images.

Change Standard Resolution

Reduces the resolution of print data to correct printing problems.

Refine screening pattern

Prints graphics with a finer screening pattern.

Allow Applications to Perform ICM Color Matching

Allows applications to perform ICM color matching.

Always Use the Driver's Paper Source Setting

Prints using the paper source setting in the printer driver, rather than the setting in your application.

Parent topic: [Selecting Extended Settings - Windows](#)

Printing Your Document or Photo - Windows

Once you have selected your print settings, you are ready to save your settings and print.

1. Click **OK** to save your settings.

You see your application's Print window, such as this one:

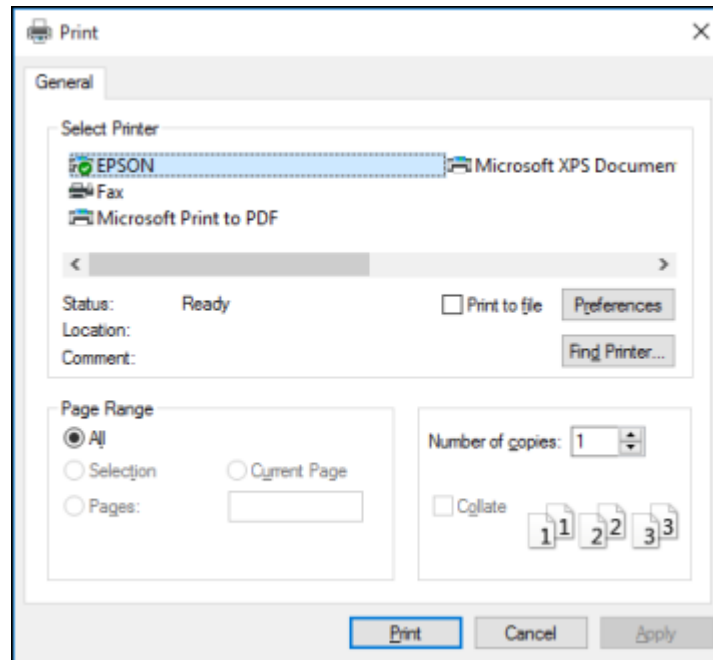

2. Click **OK** or **Print** to start printing.

[Checking Print Status - Windows](#)

Parent topic: [Printing with Windows](#)

Checking Print Status - Windows

During printing, you see this window showing the progress of your print job. It allows you to control printing and check ink cartridge status.

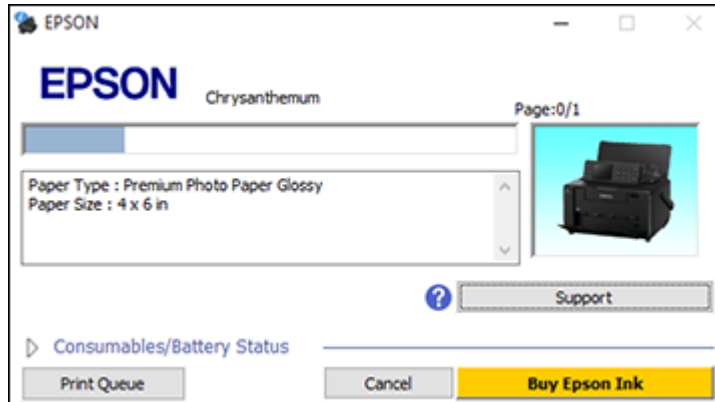

- To cancel printing, click **Cancel**.
- To see print jobs waiting to print, click **Print Queue**.
- To check ink status, click **Consumables/Battery Status**.

Parent topic: [Printing Your Document or Photo - Windows](#)

Selecting Default Print Settings - Windows

When you change your print settings in a program, the changes apply only while you are printing in that program session. If you want to change the print settings you use in all your Windows programs, you can select new default print settings.

1. Access the Windows Desktop and right-click the product icon in the Windows taskbar.
2. Select **Printer Settings**.

You see the printer settings window:

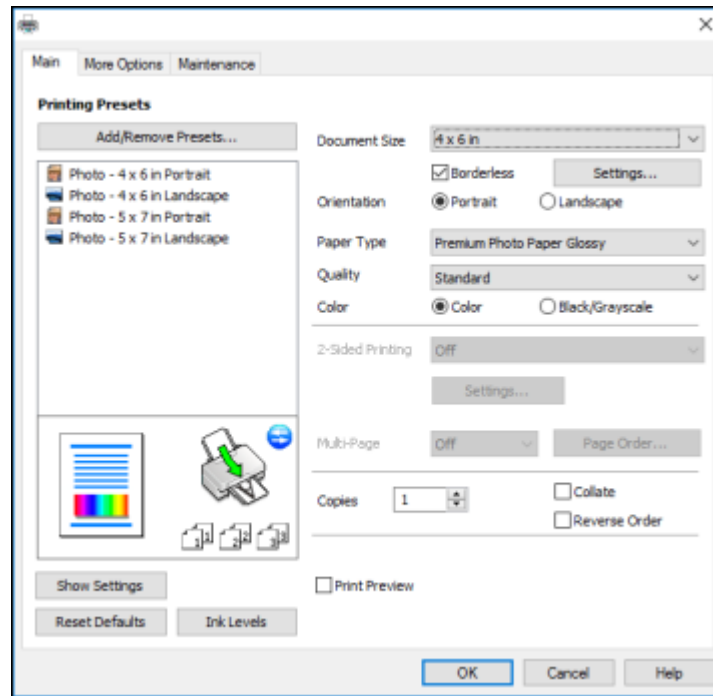

3. Select the print settings you want to use as defaults in all your Windows programs.
4. Click **OK**.

These settings are now the defaults selected for printing. You can still change them as needed for printing in any program session.

[Changing the Language of the Printer Software Screens](#)

Parent topic: [Printing with Windows](#)

Changing the Language of the Printer Software Screens

You can change the language used on the Windows printer software screens.

1. Access the Windows Desktop and right-click the product icon in the Windows taskbar.
2. Select **Printer Settings**.

You see the printer settings window.

3. Click the **Maintenance** tab.
You see the maintenance options:

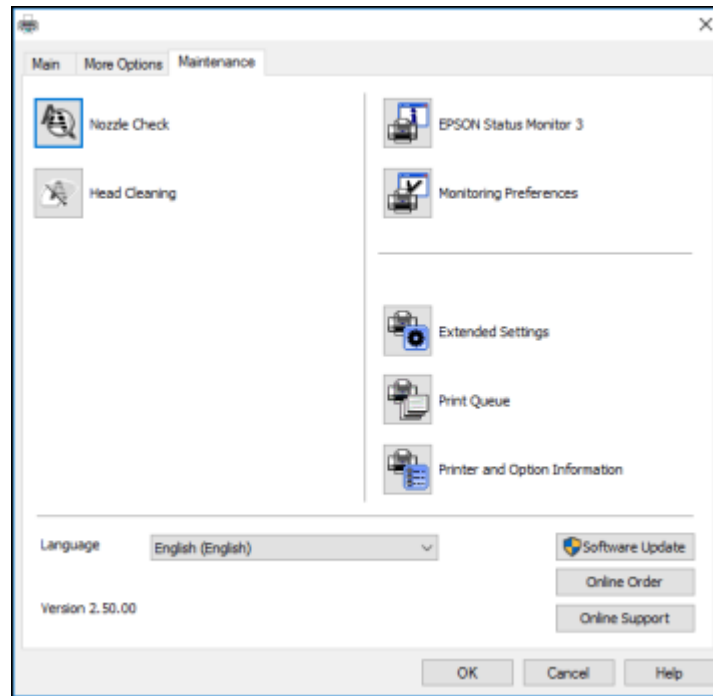

4. Select the language you want to use as the **Language** setting.
5. Click **OK** to close the printer software window.

The printer software screens appear in the language you selected the next time you access them.

Parent topic: [Selecting Default Print Settings - Windows](#)

Changing Automatic Update Options

Your printer software for Windows automatically checks for updates to the product software. You can change how often the software checks for updates or disable this feature.

1. Access the Windows Desktop and right-click the product icon in the Windows taskbar.
2. Select **Software Update Settings**.

You see this window:

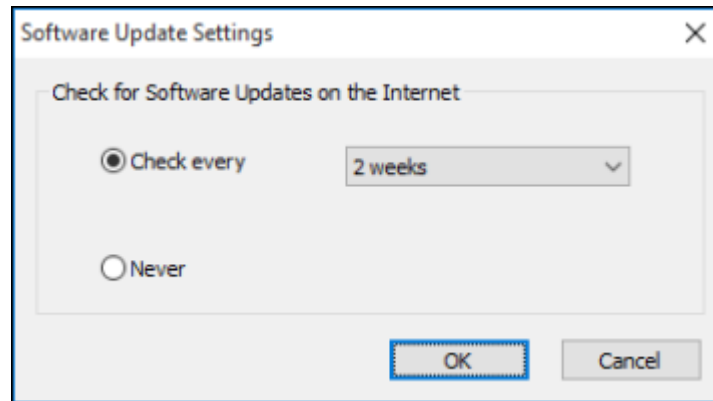

3. Do one of the following:
 - To change how often the software checks for updates, select a setting in the **Check every** menu.
 - To disable the automatic update feature, select the **Never** option.
4. Click **OK** to exit.

Note: If you choose to disable the automatic update feature, you can check for updates manually.

Parent topic: [Printing with Windows](#)

Printing on a Mac

You can print with your product using any Mac printing program, as described in these sections.

Note: If you have an Internet connection, it is a good idea to check for updates to your product software on Epson's support website.

[Selecting Basic Print Settings - Mac](#)

[Selecting Page Setup Settings - Mac](#)

[Selecting Print Layout Options - Mac](#)

[Sizing Printed Images - Mac](#)

[Managing Color - Mac](#)

[Selecting Printing Preferences - Mac](#)
[Printing Your Document or Photo - Mac](#)
Parent topic: [Printing from a Computer](#)

Selecting Basic Print Settings - Mac

Select the basic settings for the document or photo you want to print.

1. Open a photo or document for printing.
2. Select the print command in your application.

Note: You may need to select a print icon on your screen, the **Print** option in the File menu, or another command. See your application's help utility for details.

3. Select your product as the **Printer** setting.

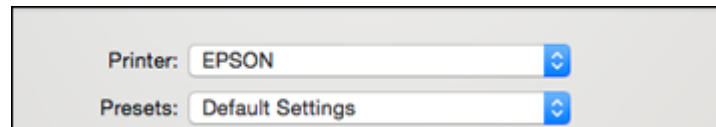

4. If necessary, click the arrow next to the Printer setting or the **Show Details** button to expand the print window.

You see the expanded printer settings window for your product:

The image shows a printer settings dialog box for an EPSON printer. The settings are as follows:

- Printer: EPSON
- Presets: Default Settings
- Copies: 1
- Pages: All, From: 1 to: 1
- Paper Size: US Letter (8.50 by 11.00 inches)
- Orientation: Portrait (selected), Landscape
- Preview: Preview
- Auto Rotate
- Scale: Scale: 100%, Scale to Fit: Print Entire Image, Fill Entire Paper
- Copies per page: 1

Buttons: Cancel, Print

Note: The print window may look different, depending on your version of the Mac operating system and the application you are using.

5. Select the **Copies** and **Pages** settings as necessary.

Note: If you do not see these settings in the print window, check for them in your application before printing.

6. Select the page setup options: **Paper Size** and **Orientation**.

Note: If you do not see these settings in the print window, check for them in your application before printing. They may be accessible by selecting **Page Setup** from the File menu.

7. Select any application-specific settings that appear on the screen, such as those shown in the image above for the Preview application.
8. Select **Print Settings** from the pop-up menu.

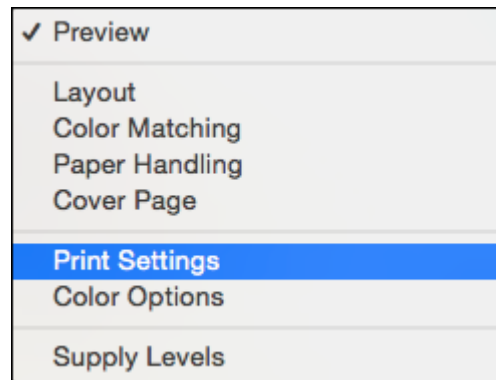

You see these settings:

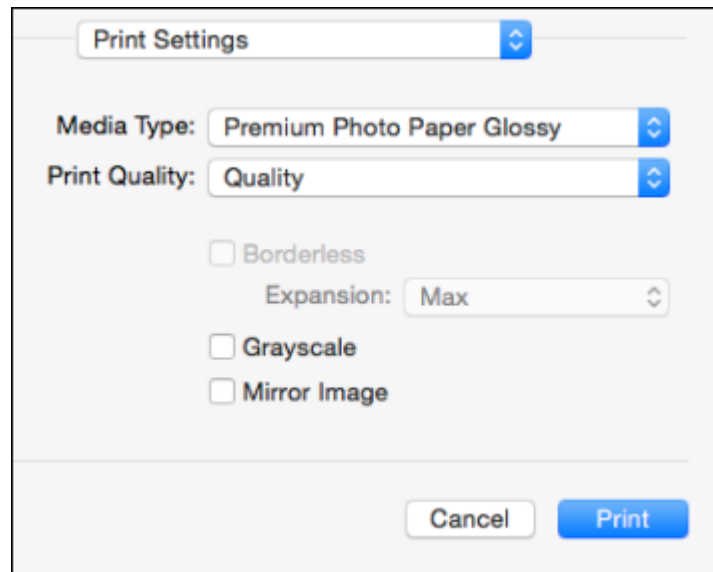

9. Select the type of paper you loaded as the **Media Type** setting.

Note: The setting may not exactly match the name of your paper. Check the paper type settings list for details.

10. Select the **Print Quality** setting you want to use.
11. Select any of the available print options.

[Print Quality Settings - Mac](#)

[Print Options - Mac](#)

Parent topic: [Printing on a Mac](#)

Related references

[Paper or Media Type Settings - Product Software](#)

Print Quality Settings - Mac

You can select any of the **Print Quality** settings to fine-tune the quality of your print. Some settings may be unavailable, depending on the paper type and border setting you have chosen.

Normal

For everyday text and image printing.

Fine

For text and graphics with good quality and print speed.

Quality

For photos and graphics with good quality and print speed.

Best Quality

For the best print quality, but the slowest print speed.

Parent topic: [Selecting Basic Print Settings - Mac](#)

Print Options - Mac

You can select any of the print options to customize your print. Some options may be unavailable, depending on other settings you have chosen.

Expansion

If you selected a borderless paper size setting, this option adjusts the image expansion settings to control printing at the edges of borderless prints.

Grayscale

Prints text and graphics in black or shades of gray.

Mirror Image

Lets you flip the printed image horizontally.

Note: If you select the **Min** option for the Expansion setting, you may see white borders on your printed photo.

Parent topic: [Selecting Basic Print Settings - Mac](#)

Selecting Page Setup Settings - Mac

Depending on your application, you may be able to select the paper size and orientation settings from the print window.

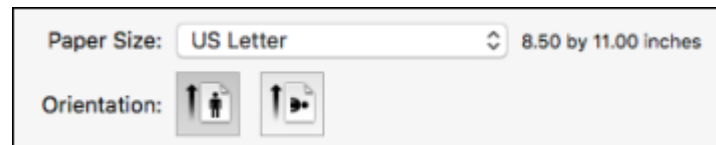

Note: If you do not see these settings in the print window, check for them in your application before printing. They may be accessible by selecting **Page Setup** from the File menu.

1. Select the size of the paper you loaded as the **Paper Size** setting. If you are printing a borderless photo, select the **Borderless** checkbox or a paper size with a **Borderless** option. You can also select a custom setting to create a custom paper size, but the Quality setting will be limited to **Normal**.

Note: You must select a compatible borderless paper type and size to print without borders. Check the borderless paper compatibility list for details.

2. Select the orientation of your document or photo as shown in the print window.

Note: If you are printing an envelope, select the  icon.

Note: You can reduce or enlarge the size of the printed image by selecting **Paper Handling** from the pop-up menu and selecting a scaling option.

Parent topic: [Printing on a Mac](#)

Related references

[Borderless Paper Type Compatibility](#)

Selecting Print Layout Options - Mac

You can select a variety of layout options for your document or photo by selecting **Layout** from the pop-up menu on the print window.

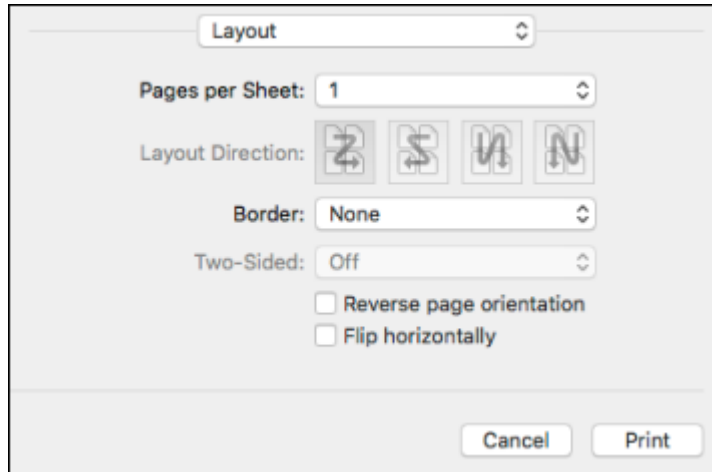

- To print multiple pages on one sheet of paper, select the number of pages in the **Pages per Sheet** pop-up menu. To arrange the print order of the pages, select a **Layout Direction** setting.
- To print borders around each page on the sheet, select a line setting from the **Border** pop-up menu.
- To invert or flip the printed image, select the **Reverse page orientation** or **Flip horizontally** settings.

Parent topic: [Printing on a Mac](#)

Sizing Printed Images - Mac

You can adjust print order and the size of the image as you print it by selecting **Paper Handling** from the pop-up menu on the Print window.

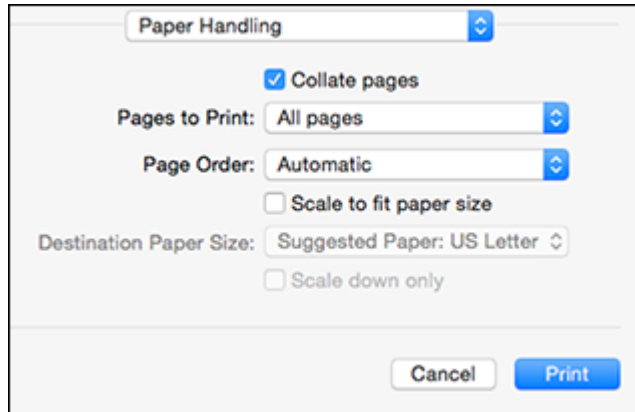

- To print only selected pages in a multi-page document, select an option from the **Pages to Print** pop-up menu.
- To adjust the order in which pages are printed, select an option from the **Page Order** pop-up menu.
- To scale the image to fit on a specific paper size, select the **Scale to fit paper size** checkbox and select a paper size from the **Destination Paper Size** pop-up menu.

Parent topic: [Printing on a Mac](#)

Managing Color - Mac

You can adjust the Color Matching and Color Options settings to fine-tune the colors in your printout, or turn off color management in your printer software.

1. Select **Color Matching** from the pop-up menu in the print window.

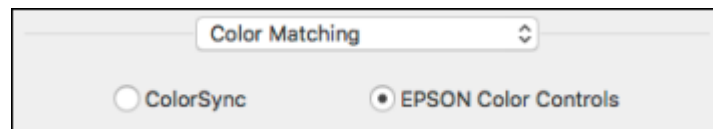

2. Select one of the available options.
3. Select **Color Options** from the pop-up menu in the print window.

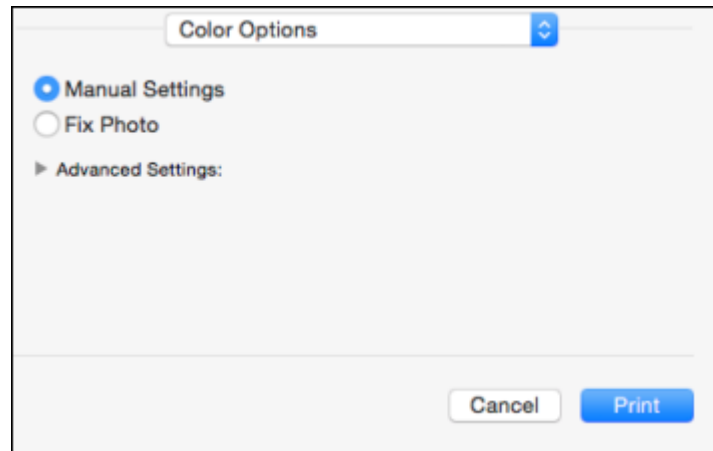

Note: The available settings on the Color Options menu depend on the option you selected on the Color Matching menu.

4. Select one of the available options.
[Color Matching and Color Options - Mac](#)

Parent topic: [Printing on a Mac](#)

Color Matching and Color Options - Mac

You can select from these settings on the **Color Matching** and **Color Options** menus.

Color Matching Settings

EPSON Color Controls

Lets you manage color using controls in your printer software or turn off color management.

ColorSync

Prints using standard color profiles for your product and paper to help match image colors. You can customize the conversion method and filter settings on the ColorSync pop-up menu in the print window.

Color Options Settings

Manual Settings

Lets you select manual color adjustments. Click the arrow next to **Advanced Settings** and select settings for **Brightness**, **Contrast**, **Saturation**, and individual color tones. You can also select a color **Mode** setting for printing photos and graphics and the **Fix Red-Eye** setting to reduce or remove red-eye in photos. Depending on the selected color mode, you can also adjust the midtone density using the **Gamma** setting.

Fix Photo

Improves the color, contrast, and sharpness of flawed photos. Click the arrow next to **Advanced Settings** and select the **Fix Red-Eye** setting to reduce or remove red-eye in photos.

Note: Fix Photo uses a sophisticated face recognition technology to optimize photos that include faces. For this to work, both eyes and the nose must be visible in the subject's face. If your photo includes a face with an intentional color cast, such as a statue, you may want to turn off **Fix Photo** to retain the special color effects.

Parent topic: [Managing Color - Mac](#)

Selecting Printing Preferences - Mac

You can select printing preferences that apply to all the print jobs you send to your product.

1. In the Apple menu or the Dock, select **System Preferences**.
2. Select **Print & Fax**, **Print & Scan**, or **Printers & Scanners**, select your product, and select **Options & Supplies**.
3. Select **Driver** or **Options**.

You see a screen like this:

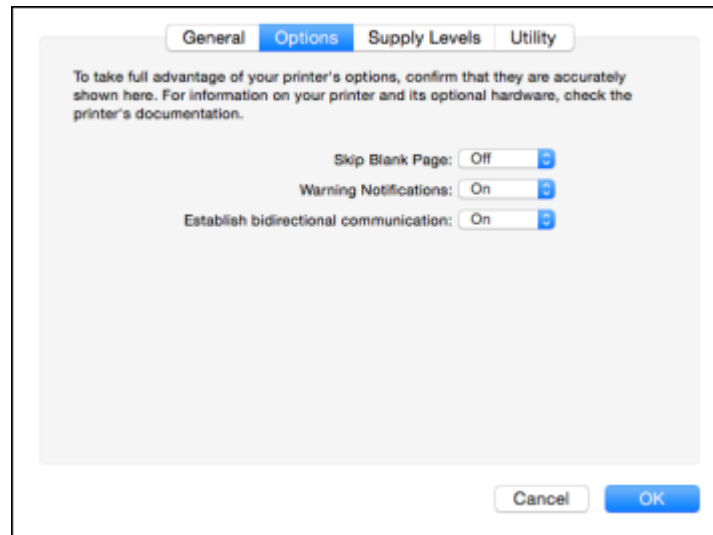

4. Select any of the available printing preferences.
5. Click **OK**.

[Printing Preferences - Mac](#)

Parent topic: [Printing on a Mac](#)

Printing Preferences - Mac

You can select from these settings on the **Options** or **Driver** tab.

Skip Blank Page

Ensures that your product does not print pages that contain no text or images.

Warning Notifications

Lets you choose whether or not to receive warning notifications from the printer software for various operating conditions.

Establish bidirectional communication

Allows the product to communicate with the computer. Do not change the default setting unless you experience issues when using a shared printing pool.

Parent topic: [Selecting Printing Preferences - Mac](#)

Printing Your Document or Photo - Mac

Once you have selected your print settings, you are ready to print.

Click **Print** at the bottom of the print window.

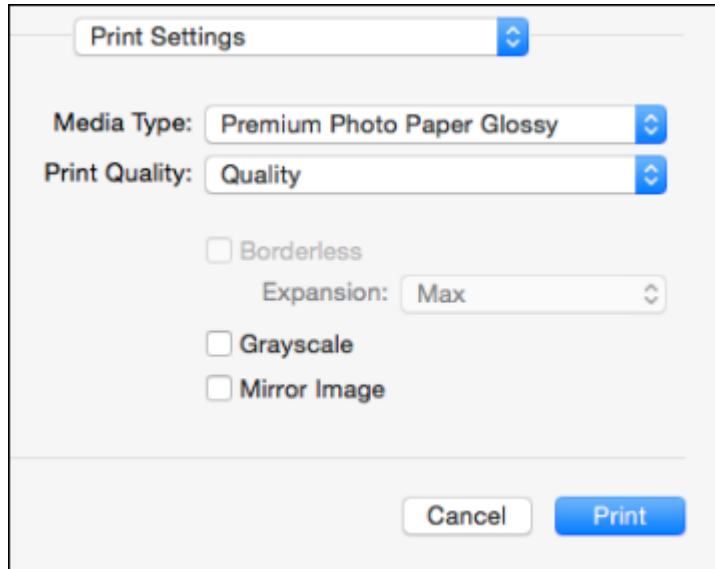

[Checking Print Status - Mac](#)

Parent topic: [Printing on a Mac](#)

Checking Print Status - Mac



During printing, you can view the progress of your print job, control printing, and check ink status.

1. Click the printer icon when it appears in the Dock.

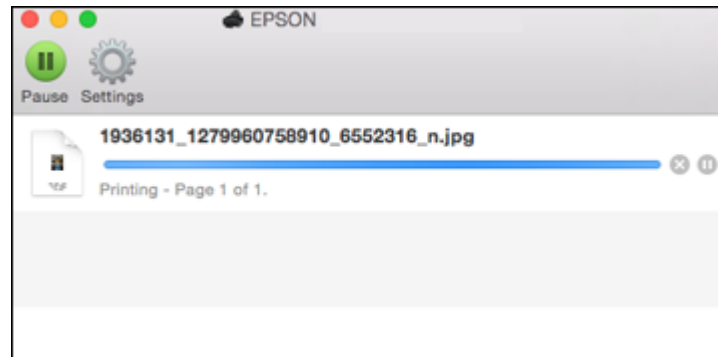
You see the print status window:



2. Select the following options as necessary for your Mac OS version:

- To cancel printing, click the print job and click  or **Delete**.
- To pause a print job, click the print job and click  or **Hold**. To resume a print job, click the paused print job and click  or **Resume**.
- To pause printing for all queued print jobs, click **Pause** or **Pause Printer**.
- To display other printer information, click **Settings** or **Supply Levels**.

Parent topic: [Printing Your Document or Photo - Mac](#)

Printing From a Chromebook

With a Google Account, you can print from a Chromebook without drivers or cables.

1. Connect your Epson product to your wireless network. See the link below.
2. Turn on your Chromebook and connect it to the same wireless network as your product.

Note: See your Chromebook's documentation for details on connecting to a network.

3. Do one of the following:

- Click **Add to Cloud Print** in the notification that appears in the corner of your Chromebook screen.

Note: If you do not see a notification, check to see if a number appears in the status area at the lower-right corner of the screen. Click this number to open the notifications menu, then click **Add to Cloud Print**.

- Open a web browser and enter **chrome://devices** in the address bar. Skip to step 4.
 - If you see a registration confirmation screen instead, click **Register**.
4. Click **Add Device**.
 5. Click the **Register** button that appears next to your product.
 6. Click **Register** on the confirmation screen. Your product's LCD screen displays a confirmation message.
 7. Select **OK** or press the **OK** button on your product to confirm the Google Cloud Print connection and print a test page.
 8. To print to the connected product, select the print command in your Chrome app.

Your product is now linked to your Google Account and can be accessed from any Chromebook where you are logged in, as long as you have Internet access. For more information on using Google Cloud Print and for a list of supported apps, visit the [Google Cloud Print](#) site.

Parent topic: [Printing from a Computer](#)

Related tasks

[Using Google Cloud Print](#)

Related topics

[Wi-Fi Networking](#)

Cancelling Printing Using a Product Button

If you need to cancel printing, press the  stop button on your product.

Parent topic: [Printing from a Computer](#)

Using Memory Cards with Your Product

Follow the instructions here to work with a memory card inserted into your product.

[Inserting a Memory Card](#)

[Printing from a Memory Card](#)

[Transferring Photos on a Memory Card](#)

Inserting a Memory Card

Insert only one memory card at a time into a memory card slot on your product.

1. Make sure the memory card and the files on it are compatible with your product before inserting the card.
2. Insert your memory card into the correct slot, making sure the card is oriented correctly.

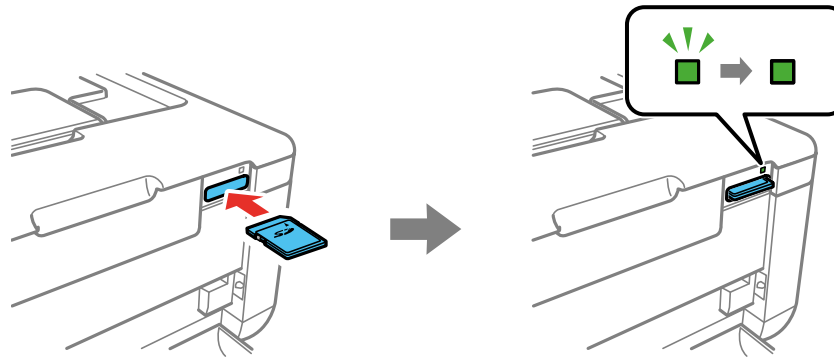

Note: Do not force the card all the way into the slot. Insert it only until it meets resistance.

The memory card access light flashes and then stays lit.

Caution: Do not remove a memory card or turn off your product while the memory card access light is flashing or you may lose data from the memory card.

[Memory Card Types](#)

[Memory Card File Specifications](#)

[Removing a Memory Card](#)

Parent topic: [Using Memory Cards with Your Product](#)

Memory Card Types

You can insert these types of memory cards in your product.

Note: Cards marked with an asterisk (*) require an adapter; consult your adapter documentation for details on using it.

You can insert the following cards in the memory card slot:

- SD: 2GB
- SDHC: 32GB
- SDXC: 64GB
- miniSD*: 2GB
- miniSDHC*: 32GB
- microSD*: 2GB
- microSDHC*: 32GB
- microSDXC*: 64GB

Parent topic: [Inserting a Memory Card](#)

Memory Card File Specifications

You can insert memory cards in your product containing files that meet these specifications.

File format	JPEG with the Exif version 2.3 standard taken with digital camera using DCF (Design rule for Camera File system) version 1.0 or 2.0 compliant
Image size	80 × 80 pixels to 10200 × 10200 pixels
File size	Up to 2GB
Number of files	Up to 9990

Parent topic: [Inserting a Memory Card](#)

Removing a Memory Card

After you finish working with a memory card, check to make sure it is safe to remove it from your product.

Caution: Do not remove a memory card or turn off your product while the memory card access light is flashing or you may lose data from the memory card.

1. Make sure the memory card access light is not flashing.

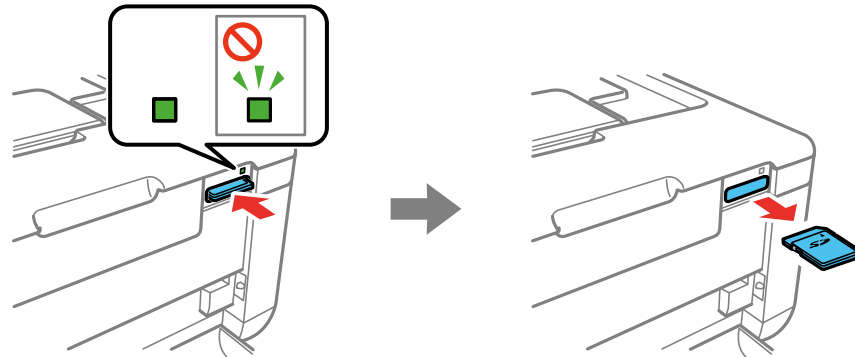

2. If your product is connected to your computer using a USB cable, do one of the following:
 - **Windows:** Open the **My Computer**, **Computer**, **Windows Explorer**, or **File Explorer** utility. Then right-click the name of your memory card (listed as a removable disk) and select **Eject**.
 - **Mac:** Drag the removable disk icon for your memory card from the desktop or computer window into the trash.
3. Push in the memory card, then pull it straight out of its slot.

Parent topic: [Inserting a Memory Card](#)

Printing from a Memory Card

See these sections to print photos from a memory card inserted into your product:

[Viewing and Printing Photos](#)

[Printing Photo Layouts](#)

[Print Setting Options](#)

[Photo Adjustment Options](#)

Parent topic: [Using Memory Cards with Your Product](#)

Viewing and Printing Photos

You can select photos for printing as you view them on the LCD screen.

1. Press the  home button, if necessary.
2. Press the arrow buttons to select **Print Photos** and press the **OK** button.
3. Select **View and Print Photos** and press the **OK** button.
A photo on your memory card is displayed.
4. Press the right or left arrow button to scroll through your photos and display one that you want to print.
5. Press the **+** or **-** button to select one or more copies of the photo (up to 99).
6. To select additional photos for printing, repeat the steps above.
7. To view additional settings, press the down arrow button.
8. Follow the on-screen instructions to select from the following options:
 - **Browse** to select photos by date
 - **Select Photos** to select all photos
 - **Display Options** to select how photos are displayed on the LCD screen
 - **Print Settings** to change the print settings
 - **Photo Adjustments** to change the appearance of your printed photos
 - **Filter** to apply a sepia tone or black-and-white filter to the viewed or printed photo
 - **Crop/Zoom** to crop or zoom into your photo

Note: When you are finished changing your settings, press the  back button.

9. When you are ready to print, press the  start button.

Note: To cancel printing, press the  stop button.

Parent topic: [Printing from a Memory Card](#)

Printing Photo Layouts

You can print one or more photos from a memory card in special layouts.

1. Press the  home button, if necessary.

2. Press the arrow buttons to select **Print Photos** and press the **OK** button.
3. Select **Photo Layout Sheet** and press the **OK** button.
4. Select one of the photo layout options and press the **OK** button.
5. Select the paper size setting that matches the paper you loaded and press the **OK** button.
6. Select the paper type setting that matches the paper you loaded and press the **OK** button.
7. If you see a screen prompting you to select a layout method, do one of the following:
 - To allow your product to place photos in the layout automatically, select **Automatic Layout** and press the **OK** button. Press the left or right arrow button to scroll through your photos, and press the **+** or **-** button to select a photo for your layout. Press the down arrow button to view additional settings. Press the **OK** button when you're finished.
 - To place photos in the layout manually, select **Place Photos Manually** and press the **OK** button. Follow the instructions on the LCD screen to select and place photos on your layout sheet.
8. When you see the screen to select the number of copies, press the **+** or **-** button to select the number of copies (up to 99) and press the **OK** button.
9. When you are ready to print, press the **⬠** start button.

Note: To cancel printing, press the **⊘** stop button.

Photo Layout Options

Parent topic: [Printing from a Memory Card](#)

Photo Layout Options

Select the layout you want to use when printing your photos in a layout.

2-up, 4-up, 8-up, or 20-up

Print 2, 4, 8, or 20 photos on one sheet.

Upper ½ or Lower ½

Print one photo in the upper or lower half of the sheet.

Photo ID

Print 4 ID-sized photos on one sheet.

P.I.F.

Print a photo with a P.I.F. frame, if a P.I.F. framed photo is on your memory card.

Parent topic: [Printing Photo Layouts](#)

Print Setting Options

Select the **Print Settings** options you want to use when printing photos from a memory card or external device.

Print settings	Available options	Description
Paper Size	Various paper sizes	Indicates the size of paper you have loaded
Paper Type	Various paper types	Indicates the type of paper you have loaded; see the list of control panel paper types (available options depend on the selected Paper Size setting)
Borderless	Borderless	Expands the image to the edge of the paper (slight cropping may occur)
	With Border	Leaves a small margin around the image
Quality	Standard	Provides good quality for most prints
	Best	Provides the highest quality for important prints
Expansion	Standard	Expands images correctly for most borderless prints
	Medium	Expands images slightly less for borderless prints
	Minimum	Expands images the least for borderless prints (you may see some white border)
Date	Various date formats	Prints the date you took the photo in the format you select
Fit Frame	On	Automatically crops the photo to fit into the selected photo layout
	Off	Turns off automatic cropping

Note: To return to default print settings, press the  stop button, select **Yes**, and press the **OK** button.

Parent topic: [Printing from a Memory Card](#)

Related references

[Paper or Media Type Settings - Product Software](#)

Photo Adjustment Options

Select the **Photo Adjustment** options you want to use when printing photos from a memory card or external device. The modifications affect only the printed copy of the photo, not the original file.

Photo Adjustment settings	Available options	Description
Fix Photo	Fix Photo On	Automatically adjusts the brightness, contrast, and saturation of the photo based on the Scene Detection setting that is selected
	Fix Photo Off	Turns off automatic adjustments; see Note below
	P.I.M.	Uses your camera's PRINT Image Matching or Exif Print adjustments
Scene Detection	Automatic	Optimizes the Fix Photo adjustments for specific types of photos; select the option that best matches your photo content
	People	
	Landscape	
	Night Scene	
Fix Red-Eye	Off - All photos	Automatically fixes the red-eye effect in photos
	On - All photos	
Sharpness	Various settings	Adjusts the sharpness of your photo
Brightness	Various settings	Adjusts the brightness of your photo

Note: To return to default print settings, press the  stop button, select **Yes**, and press the **OK** button.

Note: **Fix Photo** uses a sophisticated face recognition technology to optimize photos that include faces. For this to work, both eyes and the nose must be visible in the subject's face. If your photo includes a face with an intentional color cast, such as a statue, you may want to turn off **Fix Photo** to retain the special color effects.

Parent topic: [Printing from a Memory Card](#)

Transferring Photos on a Memory Card

You can transfer photos to and from a memory card inserted into a memory card slot on your product.

[Transferring Photos from a Memory Card to Your Computer](#)

Parent topic: [Using Memory Cards with Your Product](#)

Transferring Photos from a Memory Card to Your Computer

You can transfer photos to and from a memory card inserted in your product and a computer connected to your product over a wireless network.

Note: You cannot transfer photos if the product is connected to the computer using a USB cable. Do not transfer photos to and from a memory card while you are printing from the memory card.

1. Make sure the product is connected to the same network as the computer.
2. Insert a memory card into a memory card slot on your product.
3. Do one of the following to access your memory card files from your computer:
 - **Windows:** Open the **Computer**, **My Computer**, **Windows Explorer**, or **File Explorer** utility, then select the removable disk icon.
 - **Mac:** Select the hard drive icon on your desktop or computer window, select your product in the **SHARED** section of the sidebar (you may need to widen the sidebar to see the name), then select the **MEMORYCARD** icon.
4. Select the folder that contains your photos.
5. Drag the photos you want to transfer to the desired folder on your computer or on your memory card.

Note: Your product's LCD screen does not update to display new photos transferred to the memory card. Wait until the memory card access light stops flashing, then remove and insert the memory card to update the photos displayed.

Parent topic: [Transferring Photos on a Memory Card](#)

Using an External Device with Your Product

Follow the instructions in these sections to use your product with an external device, such as a camera, USB flash drive, or other USB device.

[Printing from a Camera](#)

[Viewing or Printing from a USB Flash Drive or External Device](#)

Printing from a Camera

If you have a digital camera that supports PictBridge printing, you can print your photos directly from the camera. Check your camera manual to see if it is compatible.

Note: Your photos must be in JPG format and sized from 80 × 80 to 10200 × 10200 pixels. Epson cannot guarantee the compatibility of your camera. Some combinations of paper type, size, and layout may not be supported, depending on your camera and the product settings.

[Selecting Print and Photo Adjustment Settings](#)



[Connecting and Printing from a Camera](#)

[Printing from a Camera Wirelessly](#)

Parent topic: [Using an External Device with Your Product](#)

Selecting Print and Photo Adjustment Settings

Before printing from your camera, you can make image adjustments and select the print settings for your photos. Image adjustments affect only the printed copy of the photo, not the original file.

1. Press the  home button, if necessary.
2. Press the arrow buttons to select **Setup** and press the **OK** button.
3. Select **External Device Setup** and press the **OK** button.
4. Select **Print Settings** and press the **OK** button.
5. Select the print settings you want to use.
6. When you are done, press the  back button.
7. Select **Photo Adjustments** and press the **OK** button.
8. Select the photo adjustments you want to use, then press the  home button to exit.

After you select settings, you are ready to connect your camera and print your photos.

Parent topic: [Printing from a Camera](#)

Related references

[Print Setting Options](#)

[Photo Adjustment Options](#)

Connecting and Printing from a Camera

Before you connect your camera, make sure the product is turned on but not printing.

1. Remove any memory cards from the product.
2. Load the paper you want to use for printing.
3. Connect the USB cable that came with your camera to the  USB port on the right side of your product.

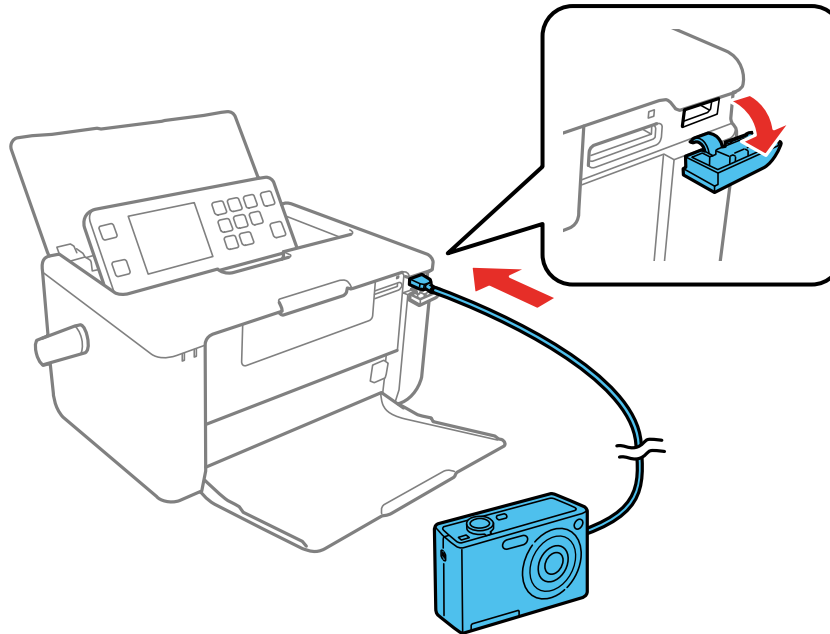

Note: You cannot use the USB port to transfer images from your camera to your computer.

4. Turn on your camera.

5. Follow the instructions that came with your camera to select and print your photos.
When you finish printing, turn off your camera and disconnect it from the product.

Parent topic: [Printing from a Camera](#)

Printing from a Camera Wirelessly

You can print photos from a digital camera using a wireless connection. Make sure your digital camera can connect to a network and is PictBridge compatible (DPS over IP).

1. Remove any memory cards from the product.
2. Load the paper you want to use for printing.
3. Turn on your camera.
4. Set up the camera's wireless network connection. See the documentation that came with your camera for details.

Note: Connect the camera to the same network that your product uses. You can check your product's network settings on the LCD screen.

5. Follow the instructions that came with your camera to select and print your photos.
When you finish printing, turn off your camera and disconnect it from the network.

Parent topic: [Printing from a Camera](#)

Viewing or Printing from a USB Flash Drive or External Device

You can view and print photos from a USB flash drive or other external USB device, such as an external hard drive or CD/DVD burner.

Note: Make sure the files on your device are compatible with the product.

[USB Device File Specifications](#)

[Connecting and Using a USB Flash Drive or External Device](#)

Parent topic: [Using an External Device with Your Product](#)

USB Device File Specifications

You can print external device files that meet these specifications.

File format	JPEG with the Exif version 2.3 standard taken with digital camera using DCF (Design rule for Camera File system) version 1.0 or 2.0 compliant
Image size	80 × 80 pixels to 10200 × 10200 pixels
File size	Up to 2GB
Number of files	Up to 9990



Note: DCF 2.0 files stored in a camera's built-in memory are not supported.

Parent topic: [Viewing or Printing from a USB Flash Drive or External Device](#)

Connecting and Using a USB Flash Drive or External Device

Before you connect your USB flash drive or device, make sure the product is turned on but not printing.

Note: Epson cannot guarantee the compatibility of your USB device.

1. Remove any memory cards from the product.
2. Load the paper you want to use for printing.
3. Insert your USB flash drive or the USB cable that came with your external device into the  USB port on the front of your product. If connecting an external CD/DVD drive, insert a CD or DVD into the drive.
4. Press the  home button, if necessary.
5. Press the arrow buttons to select **Print Photos** and press the **OK** button.
6. Select **View and Print Photos** and press the **OK** button
7. Select the photos to print from the LCD screen.

When you finish printing, make sure the access light on the drive is not flashing, then remove or disconnect it from the product.

Caution: Do not remove the USB drive or turn off the product when the access light is flashing, or you may lose photos on the drive.

Parent topic: [Viewing or Printing from a USB Flash Drive or External Device](#)

Replacing the Ink Cartridge and Maintenance Box

The maintenance box stores ink that gets flushed from the system during print head cleaning. When the ink cartridge is expended or the maintenance box is at the end of its service life, you need to replace it.

You may also need to replace a cartridge that is more than six months old if your printouts do not look their best, even after cleaning and aligning the print head.

[Check Status of the Ink Cartridge and Maintenance Box](#)

[Purchase Epson Ink Cartridges and Maintenance Box](#)

[Removing and Installing the Ink Cartridge](#)

[Replacing the Maintenance Box](#)

Check Status of the Ink Cartridge and Maintenance Box

Your product and its software will let you know when the ink cartridge is low or expended, or when the maintenance box needs to be replaced.

[Checking Cartridge and Maintenance Box Status on the LCD Screen](#)

[Checking Cartridge and Maintenance Box Status with Windows](#)

[Checking Cartridge and Maintenance Box Status on a Mac](#)

Parent topic: [Replacing the Ink Cartridge and Maintenance Box](#)

Checking Cartridge and Maintenance Box Status on the LCD Screen

You can check the status of your ink cartridge and maintenance box using your product's LCD screen.

Note: The ink cartridge and maintenance box levels are approximate.

1. Press the  home button, if necessary.
2. Press the arrow buttons to select **Setup** and press the **OK** button.
3. Select **Ink Level** and press the **OK** button.
The ink cartridge status is displayed.
4. Press the **OK** button to exit.
5. Select **Maintenance box** and press the **OK** button.
The maintenance box status is displayed.
6. Press the **OK** button to exit.

Parent topic: [Check Status of the Ink Cartridge and Maintenance Box](#)

Checking Cartridge and Maintenance Box Status with Windows

A low ink reminder appears if you try to print when ink is low, and you can check your cartridge or maintenance box status at any time using a utility on your Windows computer.

1. To check your status, access the Windows Desktop, double-click the product icon in the Windows taskbar, and click **Details**.

You see this window:



2. Replace or reinstall the maintenance box or ink cartridge as indicated on the screen.

Note: If the cartridge installed in the product is broken, incompatible with the product model, or improperly installed, Epson Status Monitor will not display an accurate cartridge status.

3. To disable the low ink reminder, right-click the product icon in the Windows taskbar and select **Monitoring Preferences**.

You see this window:

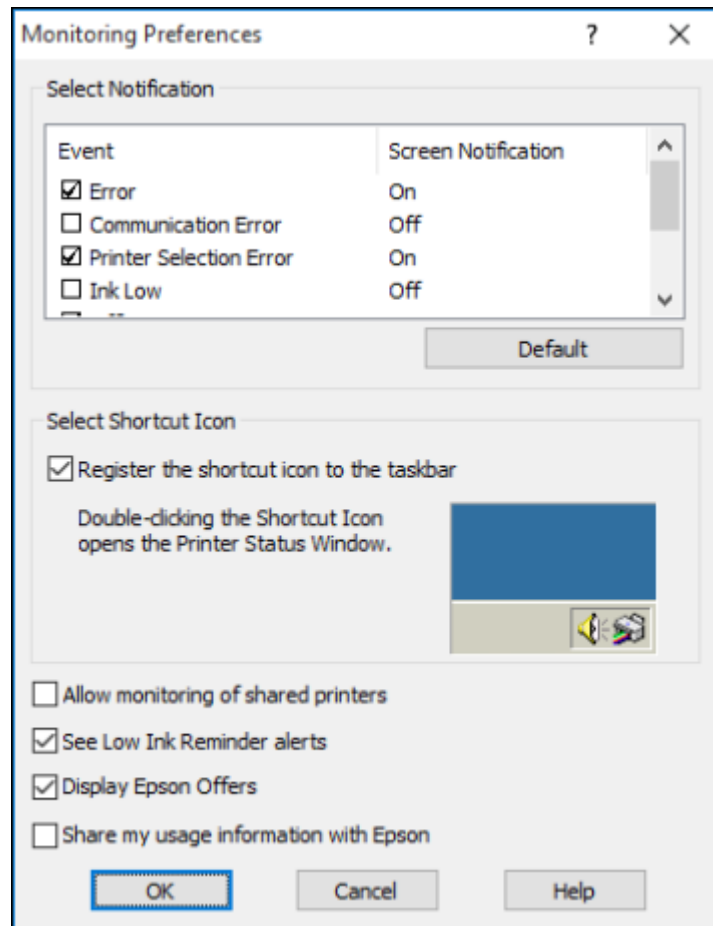

4. To disable promotional offers, deselect the **Display Epson Offers** checkbox. (Promotional offers not available in Latin America.)
5. Click **OK**.

Parent topic: [Check Status of the Ink Cartridge and Maintenance Box](#)

Related tasks

[Removing and Installing the Ink Cartridge](#)

[Replacing the Maintenance Box](#)

Checking Cartridge and Maintenance Box Status on a Mac

You can check the status of your ink cartridge and maintenance box using a utility on your Mac.

1. In the Apple menu or the Dock, select **System Preferences**. Select **Print & Fax**, **Print & Scan**, or **Printers & Scanners**, select your product, and select **Options & Supplies**. Select **Utility** and select **Open Printer Utility**.
2. Select **EPSON Status Monitor**.

You see this window:

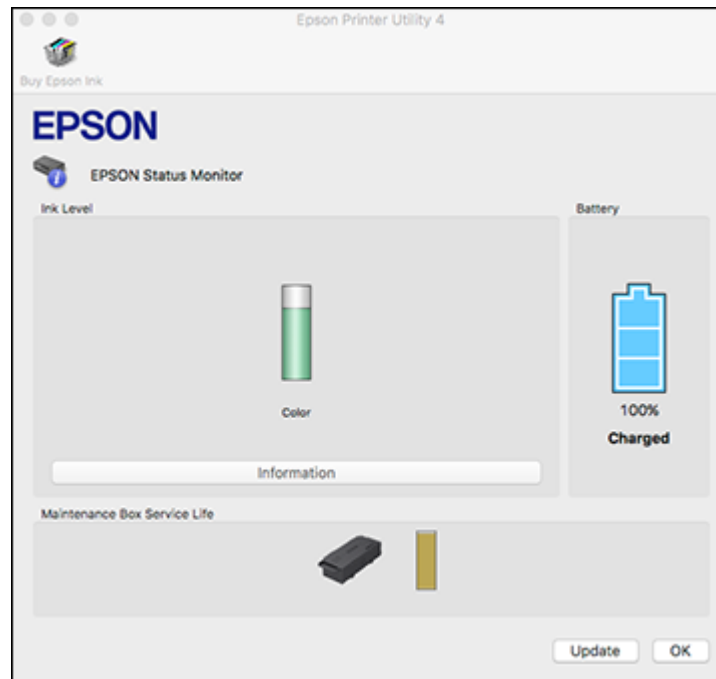

3. Do the following as necessary:

- You can update the ink cartridge and maintenance box status by clicking **Update**.
- Replace or reinstall the maintenance box or ink cartridge as indicated on the screen.

Note: If the cartridge installed in the product is broken, incompatible with the product model, or improperly installed, Epson Status Monitor will not display an accurate cartridge status.

Parent topic: [Check Status of the Ink Cartridge and Maintenance Box](#)

Related tasks

[Removing and Installing the Ink Cartridge](#)

[Replacing the Maintenance Box](#)

Purchase Epson Ink Cartridges and Maintenance Box

You can purchase genuine Epson ink, maintenance boxes, and paper from an Epson authorized reseller. To find the nearest reseller, visit epson.com.jm or call your nearest Epson sales office.

Note: This product was originally designed to work with genuine Epson ink cartridges. Your product may not function properly if you use other types of cartridges or if you use refilled cartridges.

The included cartridge must be used for printer setup and is not for resale. For more information, see latin.epson.com/infocartucho (website available in Spanish only). Yields vary considerably based on images printed, print settings, paper type, frequency of use, and temperature. For print quality, a variable amount of ink remains in the cartridge after the "replace cartridge" indicator comes on.

[Ink Cartridge and Maintenance Box Part Numbers](#)

Parent topic: [Replacing the Ink Cartridge and Maintenance Box](#)

Ink Cartridge and Maintenance Box Part Numbers

Use these part numbers when you order or purchase a new maintenance box or ink cartridges.

Note: For best printing results, use up a cartridge within 6 months of opening the package.

Part number	Description
376	Color Ink Cartridge
T2951	Maintenance box

Parent topic: [Purchase Epson Ink Cartridges and Maintenance Box](#)

Removing and Installing the Ink Cartridge

Make sure you have a replacement cartridge handy before you begin. You must install the new cartridge immediately after removing the old one.

Caution: Leave your old cartridge in the printer until you are ready to replace it to prevent the print head nozzles from drying out. Do not open ink cartridge packages until you are ready to install the ink. Cartridges are vacuum packed to maintain reliability.

Note: If you remove a low or expended ink cartridge, you cannot re-install and use the cartridge.

1. Turn on your product.
2. Do one of the following:
 - If the ink cartridge is expended, you see a message on the LCD screen. Press the **OK** button.
 - If you are replacing the cartridge before you see a message on the LCD screen, select **Setup > Maintenance > Ink Cartridge Replacement**. Then press the **OK** button to proceed.
3. Unpack the new ink cartridge and completely remove only the yellow tape.

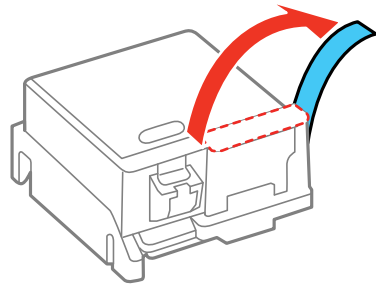

Caution: Do not remove any other labels or seals, or ink may leak.

4. Remove the cap as shown. Retain the cap so that you can use it to recap the used cartridge you are replacing.

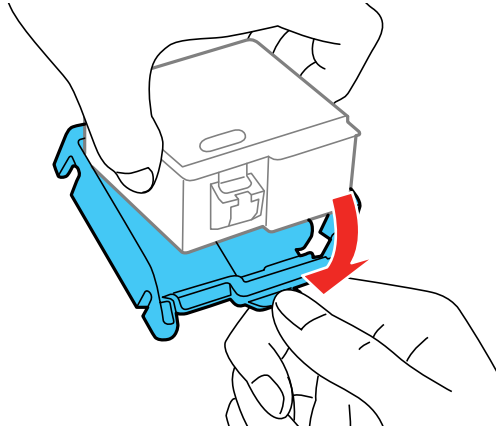

Caution: Do not touch the ink cartridge areas shown here. Doing so may prevent normal operation and printing.



Warning: If ink gets on your skin, wash it thoroughly with soap and water. If ink gets into your eyes, flush them immediately with water. If ink gets into your mouth, spit it out and see a doctor right away. Keep ink cartridges out of the reach of children.

5. Press the  start button.
The ink cartridge moves to the ink replacement position.

6. Open the printer cover.

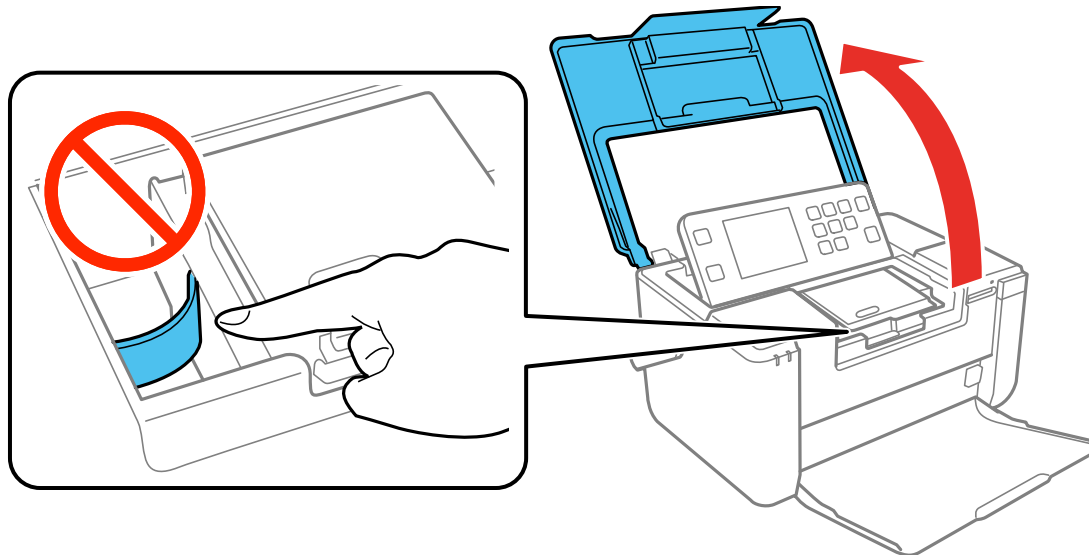

Caution: Do not move the print head by hand; otherwise, you may damage your product. Do not touch the flat white cable inside the product.

7. Press down the blue tab to unlock the used ink cartridge, then lift it out.

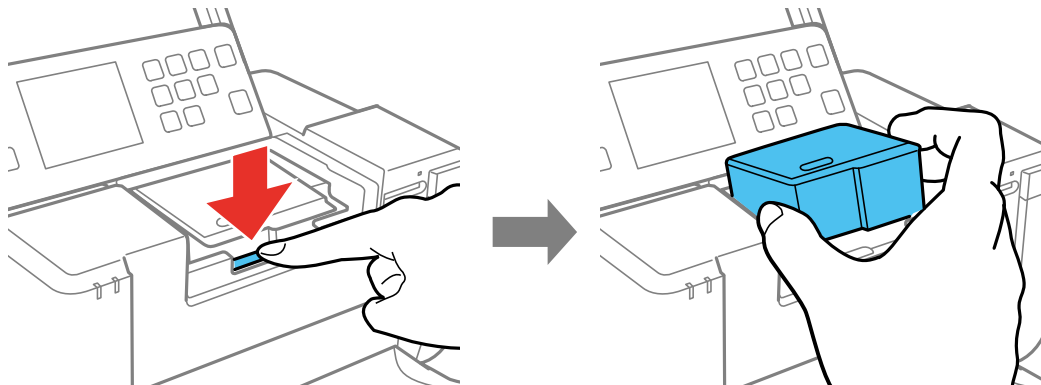

8. Use the cap from the replacement ink cartridge to recap the used cartridge before disposing of it.

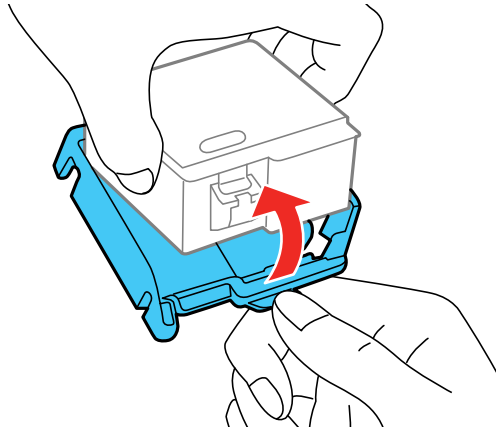

Note: Dispose of used cartridges carefully. Do not take the used cartridge apart or try to refill it.

9. Hold the cartridge with the green chip facing you and insert the cartridge at an angle as shown. Press down the ink cartridge until it clicks into place.

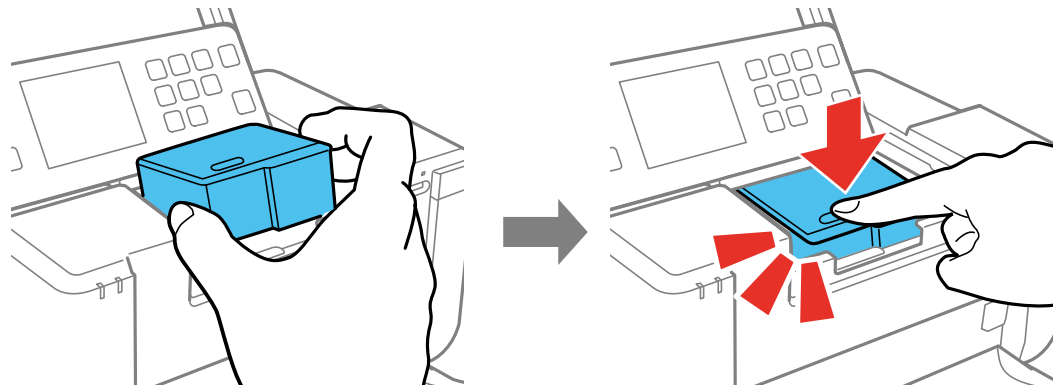

Caution: Be sure to insert the ink cartridge in the correct direction or you may damage the product.

10. Close the printer cover.

11. Press the  start button to start charging the ink. Then follow the rest of the on-screen instructions. Ink charging takes a few minutes. When you see a completion message on the LCD screen, ink replacement is complete.

Caution: Do not turn off the product while ink is charging or you may not be able to print.

Caution: If you remove an ink cartridge for later use, recap the ink cartridge using the cap that came with it to prevent the ink from drying out and to protect the surrounding area from getting smeared by ink. Store the ink cartridge in the same environment as the product. Do not leave the product with the ink cartridges removed for an extended period of time. Otherwise, ink remaining in the print head nozzles may dry out and you may not be able to print.

Parent topic: [Replacing the Ink Cartridge and Maintenance Box](#)

Replacing the Maintenance Box

Make sure you have a new maintenance box before you begin.

Caution: Do not reuse a maintenance box that has been removed and left uninstalled for more than a week. Keep the maintenance box away from direct sunlight.

1. Turn off the product using the  power button.
2. Disconnect any connected cables.
3. Remove the new maintenance box from its package, but retain the plastic bag to dispose of the used maintenance box.

Caution: Do not touch the green chip on the maintenance box.

4. Close the rear paper feed cover and output tray, move the handle forward, and flip the product over onto its back as shown.

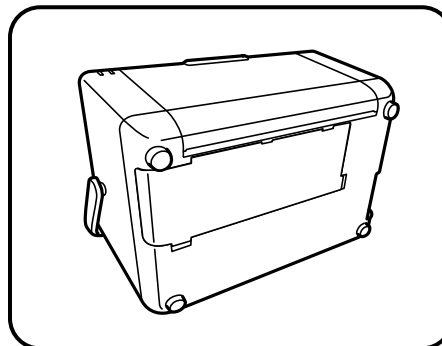
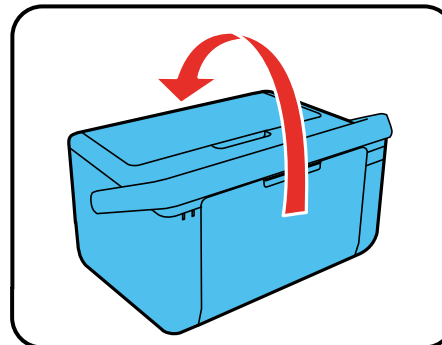
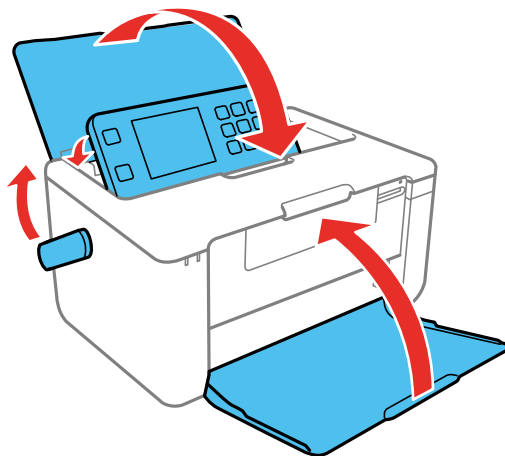

5. Push in the tabs on the maintenance box cover and remove the cover.

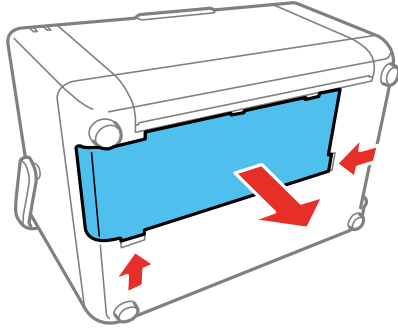

6. Slide the maintenance box as shown and remove it from the product.

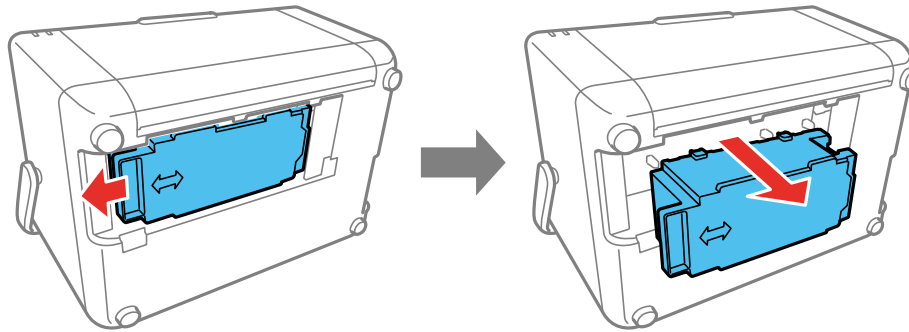

Caution: Do not touch the areas on the product or maintenance box shown here. Doing so may prevent normal operation or you may be smeared by ink.

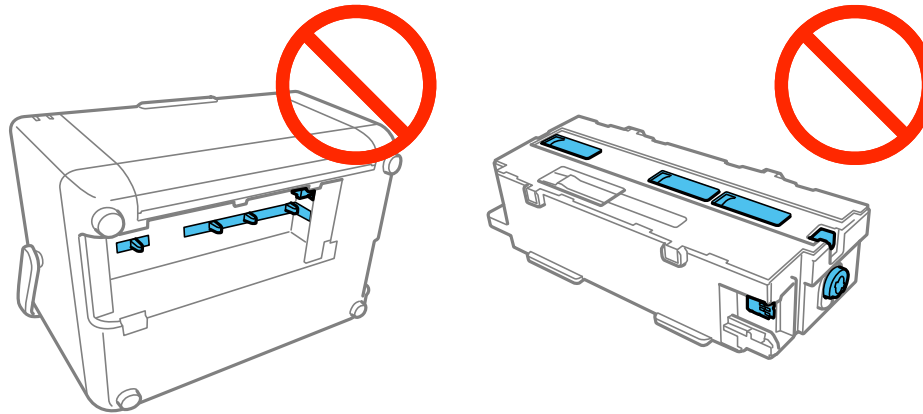

Warning: If ink gets on your skin, wash it thoroughly with soap and water. If ink gets into your eyes, flush them immediately with water. If ink gets into your mouth, spit it out and see a doctor right away. Keep ink cartridges out of the reach of children.

7. Place the used maintenance box in the plastic bag that came with the new maintenance box. Seal the bag and dispose of it carefully.

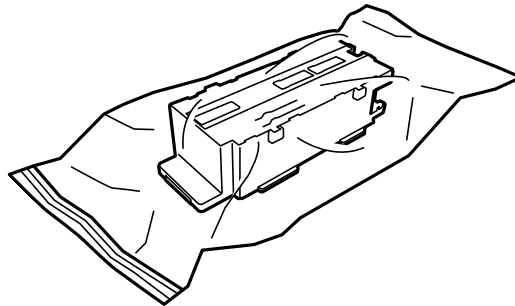

Note: Do not drop the maintenance box or subject it to strong shocks.

8. Insert the new maintenance box all the way into the product, then slide it as shown until it locks into place.

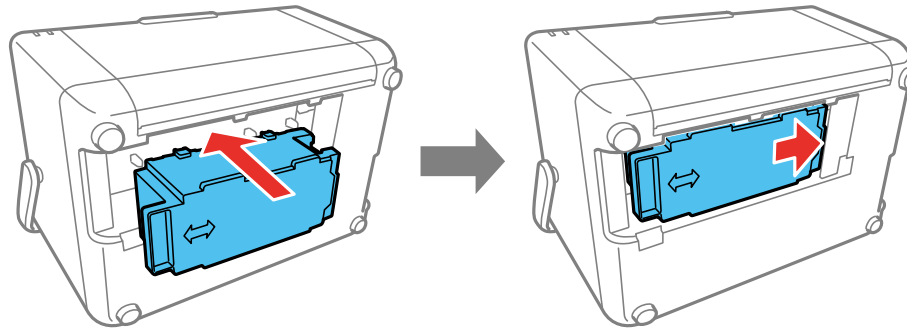

9. Insert the tabs on the maintenance box cover into the printer, then press down on the cover until it clicks into place.

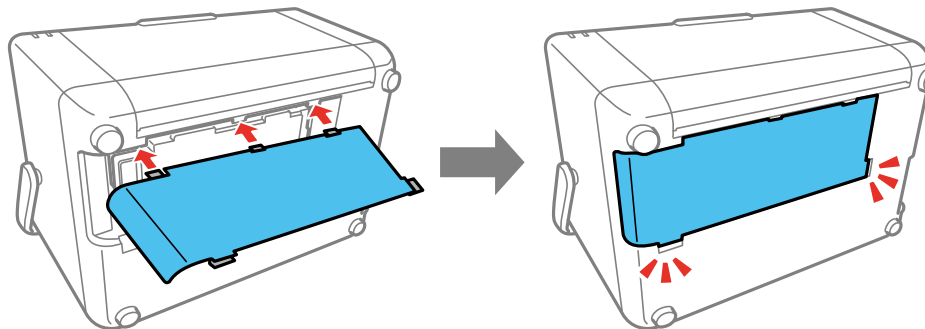

Note: If the maintenance box cover does not close, the maintenance box may not be installed correctly. Remove and reinstall the maintenance box, then try closing the cover again.

Parent topic: [Replacing the Ink Cartridge and Maintenance Box](#)

Adjusting Print Quality

If your print quality declines, you may need to run a utility to clean or align the print head.

[Print Head Maintenance](#)

[Print Head Alignment](#)

[Cleaning the Paper Path](#)

Print Head Maintenance

If your printouts become too light, or you see dark or light bands across them, you may need to clean the print head nozzles. Cleaning uses ink, so clean the nozzles only if print quality declines.

You can check for clogged nozzles before you clean them so you don't clean them unnecessarily.

Note: You cannot clean the print head if the ink cartridge is expended, and may not be able to clean it when the cartridge is low. You must replace the cartridge first.

[Print Head Nozzle Check](#)

[Print Head Cleaning](#)

Parent topic: [Adjusting Print Quality](#)

Related topics

[Replacing the Ink Cartridge and Maintenance Box](#)

Print Head Nozzle Check

You can print a nozzle check pattern to check for clogged nozzles.

[Checking the Nozzles Using the Product Control Panel](#)

[Checking the Nozzles Using a Computer Utility](#)

Parent topic: [Print Head Maintenance](#)

Checking the Nozzles Using the Product Control Panel

You can check the print head nozzles using the control panel on your product.

1. Load paper in this size in your product: 3.5 × 5 inches (89 × 127 mm) or larger.
2. Press the  home button, if necessary.
3. Press the arrow buttons to select **Setup** and press the **OK** button.

4. Select **Maintenance** and press the **OK** button.
5. Select **Nozzle Check** and press the **OK** button.
6. Press the  start button.
The nozzle check pattern is printed.
7. Check the printed pattern to see if there are gaps in the lines.

Print head is clean

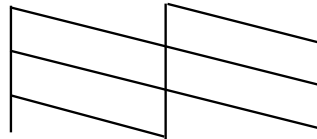

Print head needs cleaning

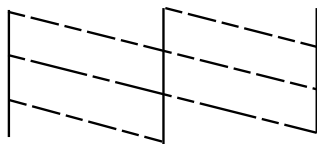

8. Do one of the following:
 - If there are no gaps, the print head is clean. Select **Finish Nozzle Check** and press the **OK** button.
 - If there are gaps or the pattern is faint, select **Head Cleaning** and press the **OK** button. Follow the instructions on the screen to clean the print head, check the nozzles, and repeat the process as necessary.

If you don't see any improvement after cleaning the print head up to 2 times, turn the product off and wait at least 6 hours. Then check the print head nozzles and try cleaning the print head again, if necessary. If quality still does not improve, contact Epson.

Parent topic: [Print Head Nozzle Check](#)

Related tasks

[Cleaning the Print Head Using the Product Control Panel](#)

Checking the Nozzles Using a Computer Utility

You can check the print head nozzles using a utility on your Windows or Mac computer.

1. Load paper in this size in your product: 3.5 × 5 inches (89 × 127 mm) or larger.
2. Do one of the following:
 - **Windows:** Access the Windows Desktop and right-click the product icon in the Windows taskbar.
 - **Mac:** In the Apple menu or the Dock, select **System Preferences**. Select **Print & Fax**, **Print & Scan**, or **Printers & Scanners**, select your product, and select **Options & Supplies**. Select **Utility** and select **Open Printer Utility**.
3. Select **Nozzle Check**.

You see a window like this:

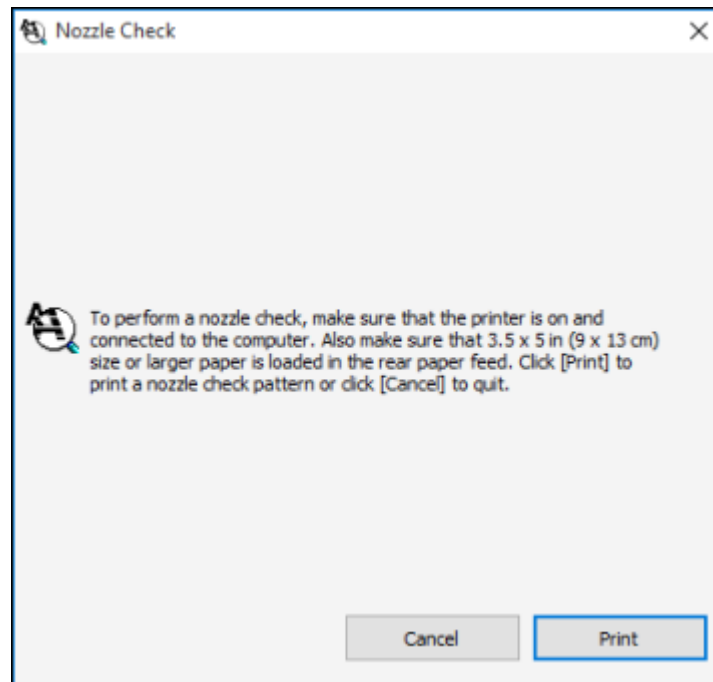

4. Click **Print**.

5. Check the printed pattern to see if there are gaps in the lines.

Print head is clean

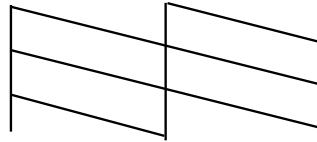

Print head needs cleaning

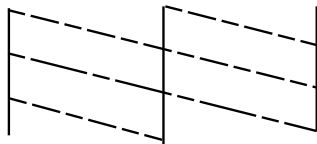

6. If there are no gaps, click **Finish**.
If there are gaps or the pattern is faint, clean the print head.

Parent topic: [Print Head Nozzle Check](#)

Related tasks

[Cleaning the Print Head Using a Computer Utility](#)

Print Head Cleaning

If print quality has declined and the nozzle check pattern indicates clogged nozzles, you can clean the print head.

Note: You cannot clean the print head if the ink cartridge is expended, and may not be able to clean it when the cartridge is low. You must replace the cartridge first.



[Cleaning the Print Head Using the Product Control Panel](#)

[Cleaning the Print Head Using a Computer Utility](#)

Parent topic: [Print Head Maintenance](#)

Cleaning the Print Head Using the Product Control Panel

You can clean the print head nozzles using the control panel on your product.

1. Load paper in this size in your product: 3.5 × 5 inches (89 × 127 mm) or larger.
2. Press the  home button, if necessary.
3. Press the arrow buttons to select **Setup** and press the **OK** button.
4. Select **Maintenance** and press the **OK** button.
5. Select **Head Cleaning** and press the **OK** button.
6. Press the  start button to clean the print head.

Caution: Never turn off the product during a cleaning cycle or you may damage it.

You see a print head cleaning message on the LCD screen during the cleaning cycle. When the cleaning cycle is finished, you see a completion message on the display screen.

7. Select **Nozzle Check** and press the **OK** button.
8. Press the  start button to run a nozzle check and confirm that the print head is clean.

If you don't see any improvement after cleaning the print head up to 2 times, turn the product off and wait at least 6 hours. Then check the print head nozzles and try cleaning the print head again, if necessary. If quality still does not improve, contact Epson.

Parent topic: [Print Head Cleaning](#)

Related tasks

[Checking the Nozzles Using the Product Control Panel](#)

Cleaning the Print Head Using a Computer Utility

You can clean the print head using a utility on your Windows or Mac computer.

1. Load paper in this size in your product: 3.5 × 5 inches (89 × 127 mm) or larger.
2. Do one of the following:
 - **Windows:** Access the Windows Desktop and right-click the product icon in the Windows taskbar.
 - **Mac:** In the Apple menu or the Dock, select **System Preferences**. Select **Print & Fax**, **Print & Scan**, or **Printers & Scanners**, select your product, and select **Options & Supplies**. Select **Utility** and select **Open Printer Utility**.
3. Select **Head Cleaning**.

You see a window like this:

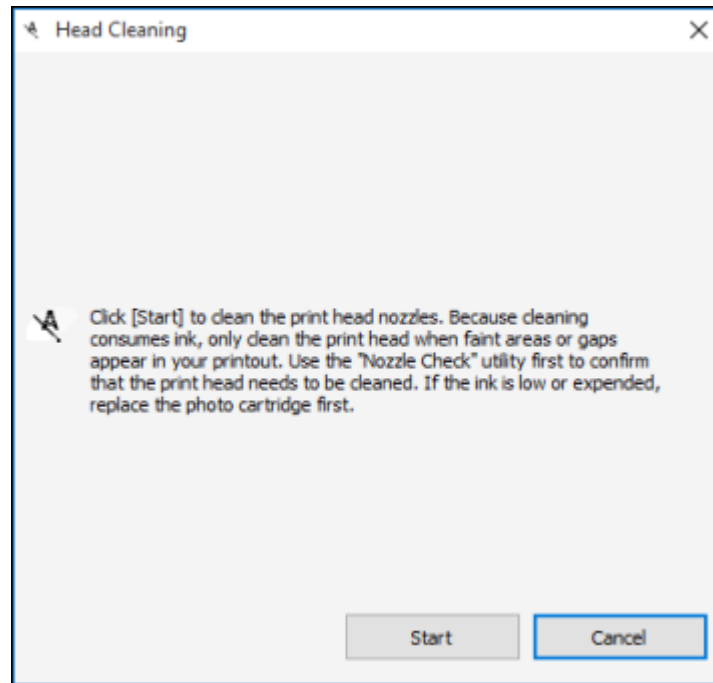

4. Click **Start** to begin the cleaning cycle.

Caution: Never turn off the product during a cleaning cycle or you may damage it.

5. When the cleaning cycle is finished, you can check to see if the nozzles are clean; click **Print Nozzle Check Pattern** and click **Print**.
6. Check the printed pattern to see if there are gaps in the lines.

Print head is clean

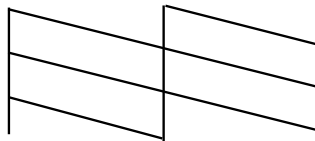

Print head needs cleaning

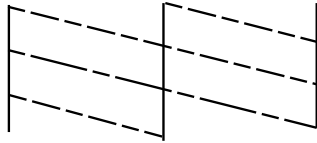

- If there are no gaps, click **Finish**.
- If there are gaps or the pattern is faint, click **Clean** to clean the print head again.

If you don't see any improvement after cleaning the print head up to 2 times, turn the product off and wait at least 6 hours. Then check the print head nozzles and try cleaning the print head again, if necessary. If quality still does not improve, contact Epson.

Parent topic: [Print Head Cleaning](#)

Related tasks

[Checking the Nozzles Using a Computer Utility](#)

Print Head Alignment

If your printouts become grainy or blurry, you notice misalignment of vertical lines, or you see dark or light horizontal bands, you may need to align the print head.

Note: Banding may also occur if your print head nozzles need cleaning.

[Aligning the Print Head Using the Product Control Panel](#)

Parent topic: [Adjusting Print Quality](#)

Aligning the Print Head Using the Product Control Panel

You can align the print head using the control panel on your product.

1. Load photo paper in this size in your product: 4 × 6 inches (102 × 152 mm).
2. Press the  home button, if necessary.
3. Press the arrow buttons to select **Setup** and press the **OK** button.
4. Select **Maintenance** and press the **OK** button.
5. Select **Print Head Alignment** and press the **OK** button.

6. Press the  start button to print an alignment sheet.

Note: Do not cancel printing while you are printing a head alignment pattern.

7. Check the printed pattern and press the up or down arrow button to select the number representing the most solid printed pattern for the first set, then press the **OK** button.

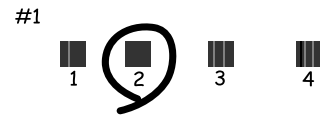

8. Repeat the previous step to select the best printed pattern for each set.

Parent topic: [Print Head Alignment](#)

Cleaning the Paper Path

If your printouts are smeared or scuffed, or your paper does not feed correctly, clean the paper path inside the printer using plain paper or the cleaning sheet that came with your product.

Caution: Do not use tissues to clean the rollers inside the product; lint from tissues may clog the print head nozzles.

Note: If paper does not feed correctly, wipe the area shown here with a soft, dry cloth before using the cleaning sheet. Otherwise the cleaning sheet may not work correctly.

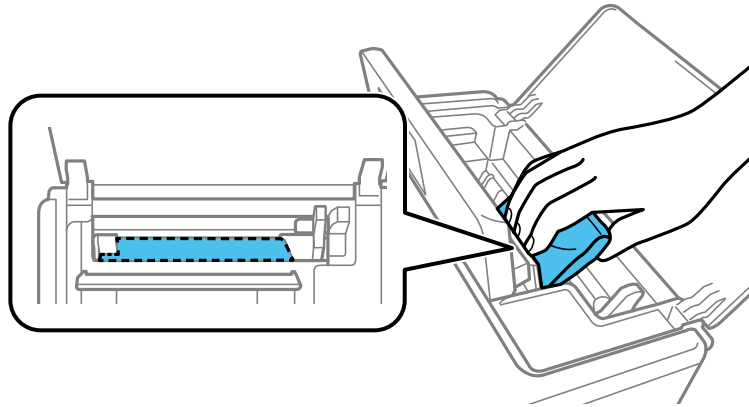

1. Do one of the following:

- If printouts are smeared or scuffed, load several sheets of plain paper.
- If paper does not feed correctly, remove the protective sheet from the cleaning sheet that came with your product and load the cleaning sheet as shown.

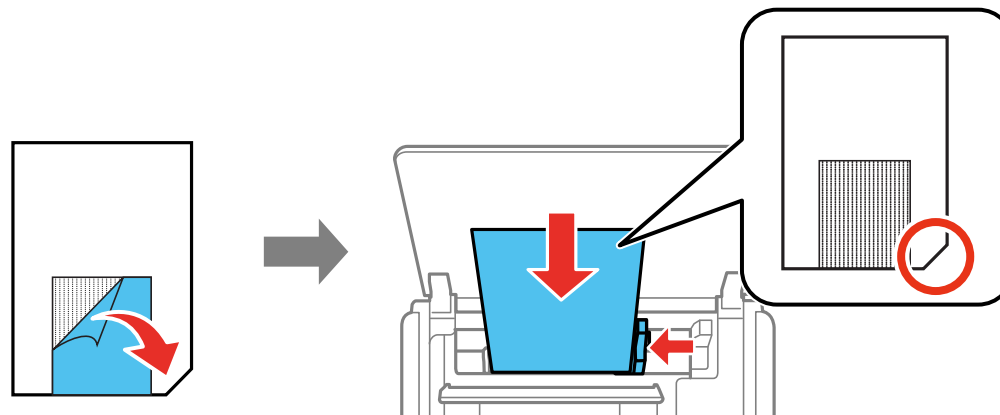

2. Press the  home button, if necessary.

3. Press the arrow buttons to select **Setup** and press the **OK** button.
4. Select **Maintenance** and press the **OK** button.
5. Select **Paper Guide Cleaning** and press the **OK** button.
6. Follow the on-screen instructions to clean the paper path.
7. Do one of the following:
 - If you loaded plain paper, repeat the previous steps as necessary until the paper is not smeared with ink.
 - If you loaded a cleaning sheet, repeat the previous steps up to three times as necessary. (The cleaning sheet loses its effectiveness when used three times or more.)

Parent topic: [Adjusting Print Quality](#)

Transporting and Cleaning Your Product

Follow the instructions in these sections to transport your product or clean it if necessary.

[Carrying and Transporting Your Product](#)

[Cleaning Your Product](#)

Carrying and Transporting Your Product

Whenever you transport your product, prepare it as described here.

Caution: Observe the following precautions when transporting the product:

- Avoid tilting the product, placing it vertically, or turning it upside down; otherwise ink may leak.
- Leave the ink cartridge installed. Removing the cartridge can dry out the print head and may prevent the product from printing.
- Avoid strong impacts which may damage the product.
- Do not leave the product in direct sunlight, near heat sources, or inside cars or other hot locations. The product may be deformed or ink may leak.

1. Press the  power button to turn off the product.
2. Make sure the power light on the front of the product is turned off and then unplug the power cord.

Caution: Make sure the power light is off before unplugging the power cord; otherwise, the print head may not return to the home position. This can cause the print head to dry out and may prevent the product from printing.

3. Remove any loaded paper.
4. Remove any memory cards inserted in the product.
5. Disconnect any connected cables.

6. Open the printer cover and secure the ink cartridge holder to the case with tape as shown.

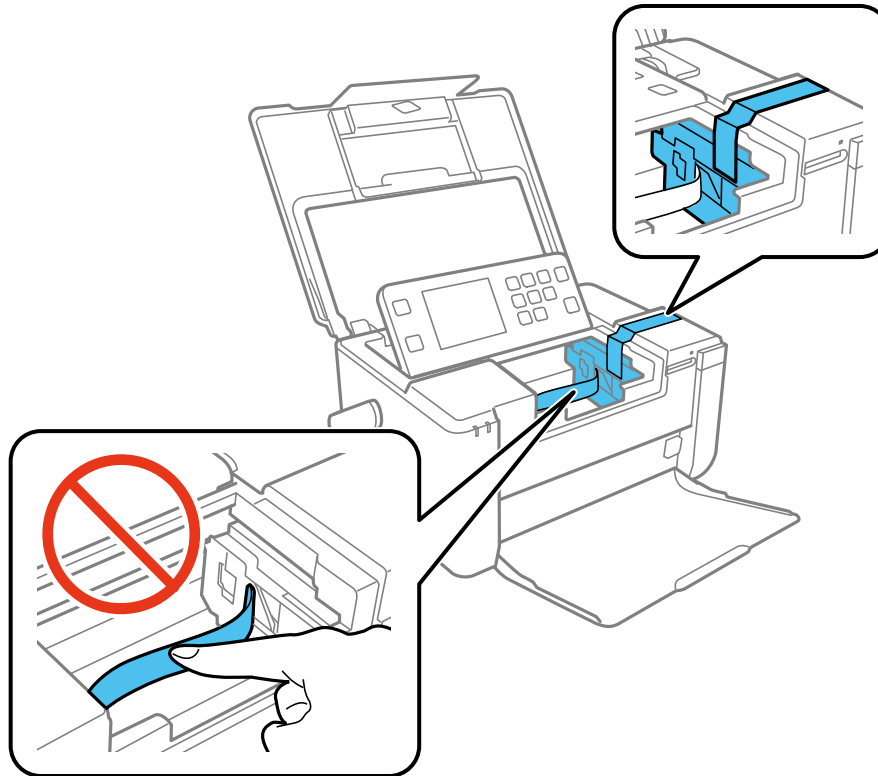

Caution: Do not touch the flat white cable inside the product.

7. Close the covers on the product as shown.

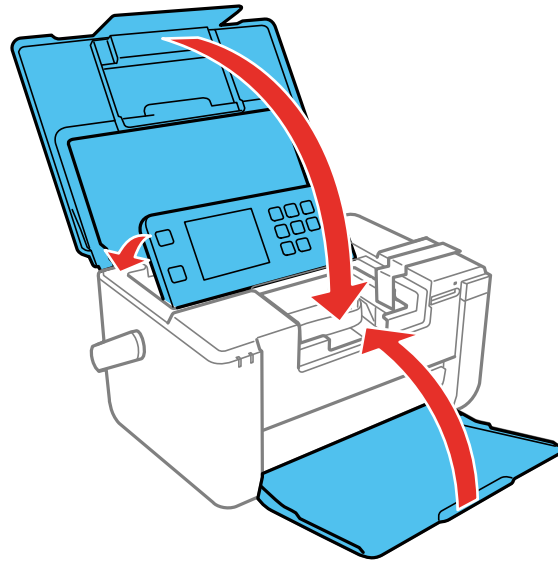

8. Place the product in its original packaging materials (or equivalent packing materials) when transporting the product a long distance.

If print quality has declined when you print again, clean and align the print head.

Parent topic: [Transporting and Cleaning Your Product](#)

Related concepts

[Print Head Maintenance](#)

[Print Head Alignment](#)

Cleaning Your Product

To keep your product working at its best, you should clean it whenever necessary. Close the cover and output tray when you are not using the product to protect it from dust.

Caution: Do not use a hard brush, benzene, alcohol, or paint thinner to clean the product or you may damage it. Do not use oil or other lubricants inside the product or let water get inside.

1. Turn off the product.

2. Unplug the power cable.
3. Disconnect any connected cables.
4. Remove any loaded paper.
5. Remove any memory cards inserted in the product.
6. Clean the outer case and control panel with a soft, dry cloth. Do not use any liquid or chemical cleansers.

Parent topic: [Transporting and Cleaning Your Product](#)

Solving Problems

Check these sections for solutions to problems you may have using your product.

[Checking for Software Updates](#)

[Product Status Messages](#)

[Running a Product Check](#)

[Resetting Control Panel Defaults](#)

[Solving Power and Battery Problems](#)

[Solving Setup Problems](#)

[Solving Network Problems](#)

[Solving Paper Problems](#)

[Solving Problems Printing from a Computer](#)

[Solving Page Layout and Content Problems](#)

[Solving Print Quality Problems](#)

[Solving Memory Card Problems](#)

[Uninstall Your Product Software](#)

[Where to Get Help](#)

Checking for Software Updates

Periodically, it's a good idea to check Epson's support website for free updates to your product software. Visit epson.com/jm/support and select your product.

- **Windows:** Your printer software automatically checks for updates. You can also manually update the software by selecting **Software Update** here:
 - Accessing the Windows Desktop and right-clicking the product icon in the Windows taskbar
 - On the **Maintenance** tab in the printer settings window

You can also update the software by selecting **EPSON Software Updater** in the **EPSON** or **EPSON Software** program group, accessible by the **Start** button, or on the **Start** or **Apps** screens, depending on your version of Windows.

- **OS X:** You can manually update the software by opening the **Applications > Epson Software** folder and selecting **EPSON Software Updater**.
- **macOS 10.12.x:** You can manually update the software by opening the **App Store**, selecting **Updates**, searching for a software update option for Epson Software, and selecting **Update**.

Parent topic: [Solving Problems](#)

Product Status Messages

You can often diagnose problems with your product by checking the messages on its LCD screen. You can also see help information and how-to instructions on the screen. Press the  home button, if necessary, select **Help**, and press the **OK** button.

LCD screen message	Condition/solution
Printer error	Turn the product off and then back on again. If the error continues, check for a paper jam. If there is no paper jam, contact Epson for support.
Ink low	You can continue printing until you are prompted to replace the ink cartridge.
You need to replace the ink cartridge	Replace the ink cartridge.
Paper Configuration is disabled	The Paper Configuration setting must be turned on to use AirPrint. Keep this setting enabled unless you always use the same size and type of paper and do not need to change the paper settings.
Battery error	The battery may be damaged. Replace the battery or contact Epson for support.
There is a problem with the battery	
The printer's ink pad is nearing the end of its service life	The ink pad is near the end of its service life and the message will be displayed until the ink pad is replaced. Contact Epson for support. (To resume printing, press the  start button.)
The printer's ink pad is at the end of its service life	The ink pad is at the end of its service life. Turn off the product and contact Epson for support.
Combination of IP address and subnet mask is invalid	There is a problem with the network connection to your product. Check the solution links in this topic.
Update the root certificate to use cloud services	Use Web Config to update the root certificate.

LCD screen message	Condition/solution
Recovery mode	An error has occurred during firmware updating. Connect the AC adapter to the product and connect the product to your computer using a USB cable, then try updating the firmware again. If you still see this error message, contact Epson for support.

Note: The ink pads in the printer collect, distribute, and contain the ink that is not used on printed pages. During the life of your product it may reach a condition where either satisfactory print quality cannot be maintained or the ink pads have reached the end of their usable life. The Epson Status Monitor, your LCD screen, or lights on the control panel will advise you when these parts need replacing. If this happens during the standard warranty of the product, the exchange of the product or replacement of the pads is covered under the standard warranty. If the product is out of warranty, the pads can be replaced by any Epson authorized service provider. The waste ink pads are not a user-replaceable part.

Parent topic: [Solving Problems](#)

Related references

[Paper Jam Problems Inside the Product](#)

[Where to Get Help](#)

Related tasks

[Selecting the Paper Settings - Control Panel](#)

[Accessing the Web Config Utility](#)

Related topics

[Replacing the Ink Cartridge and Maintenance Box](#)

[Using the Optional Battery](#)

[Solving Network Problems](#)

Running a Product Check

Running a product check helps you determine if your product is operating properly.

1. Disconnect any interface cables connected to your product.
2. Load paper in this size in your product: 3.5 × 5 inches (89 × 127 mm) or larger.
3. Press the  home button, if necessary.
4. Press the arrow buttons to select **Setup** and press the **OK** button.
5. Select **Maintenance** and press the **OK** button.

6. Select **Nozzle Check** and press the **OK** button.
7. Press the  start button.
The nozzle check pattern is printed.
8. Do one of the following, depending on the results of the product check:
 - If the page prints and the nozzle check pattern is complete, the product is operating properly. Any operation problem you may have could be caused by your computer, cable, software, or selected settings. Check for other solutions or try uninstalling and reinstalling your printer software.
 - If the page prints but the nozzle check pattern has gaps, clean or align the print head.
 - If the page does not print, the product may have a problem. Check for other solutions. If they do not work, contact Epson.

Parent topic: [Solving Problems](#)

Related concepts

[Uninstall Your Product Software](#)

[Print Head Maintenance](#)

[Print Head Alignment](#)

Resetting Control Panel Defaults

If you have a problem with settings on the product control panel, you can reset them to their factory defaults. You can choose which settings to reset or reset them all.

1. Press the  home button, if necessary.
2. Press the arrow buttons to select **Setup** and press the **OK** button.
3. Select **Restore Default Settings** and press the **OK** button.
4. Select one of these options:
 - **Network Settings:** Resets all network settings.
 - **All Except Network Settings:** Resets all control panel settings, except for network settings.
 - **All Settings:** Resets all control panel settings.You see a confirmation screen.
5. Select **Yes** to reset the selected settings. (Select **No** if you want to cancel the operation.)

Parent topic: [Solving Problems](#)

Solving Power and Battery Problems

Check these sections if you have power or battery problems.

[Product Does Not Turn On](#)

[Product Does Not Turn Off](#)

[Product Turns Off Automatically](#)

Parent topic: [Solving Problems](#)

Product Does Not Turn On

If your product does not turn on, try these solutions:

- Make sure the power cord is securely plugged in to your product and the electrical outlet.
- Hold down the  power button for a few seconds.
- If the product was running on the battery, the battery may be running low. Connect the AC adapter and charge the battery for at least 30 minutes, then turn on the product again.



Parent topic: [Solving Power and Battery Problems](#)

Related tasks

[Charging the Battery Using the AC Adapter](#)

Product Does Not Turn Off

If your product does not turn off, try this solution:

1. Disconnect the AC adapter and the USB cable.
2. Hold down the  power button and the  stop button at the same time for more than 7 seconds, then release both buttons.
3. To prevent the print head from drying out, turn the printer back on, then turn it off by pressing the  power button.

Parent topic: [Solving Power and Battery Problems](#)

Product Turns Off Automatically

If your product turns off automatically, try these solutions:

- The LCD screen turns off when the product goes into sleep mode. Press any button to turn the screen on.

- The product's power off timer turns it off when it is not in use. Press the  power button to turn it back on.
- If the product was running on the battery, you may have to connect the AC adapter to charge the battery.

Parent topic: [Solving Power and Battery Problems](#)

Related tasks

[Charging the Battery Using the AC Adapter](#)

Related topics

[The Power Off and Sleep Timers](#)

Solving Setup Problems

Check these sections if you have problems while setting up your product.

[Noise After Ink Installation](#)

[Software Installation Problems](#)

[USB Connection Problems](#)

Parent topic: [Solving Problems](#)

Noise After Ink Installation

If you hear noises from your product after installing ink, check the following:

- The first time you install the ink cartridge, the product must charge its print head. Wait until charging finishes before you turn off the product, or it may charge improperly and use excess ink the next time you turn it on.
- If the product's print head stops moving or making noise, and the charging process has not finished after approximately 5 minutes, turn off your product. Turn it back on and check to see if charging is still in progress. If it is still in progress, contact Epson for help.

Parent topic: [Solving Setup Problems](#)

Software Installation Problems

If you have problems while installing your product software, try these solutions:

- Make sure your product is turned on and any necessary cables are securely connected at both ends. If you still have problems installing software, disconnect the cable and carefully follow the instructions on the *Start Here* sheet. Also make sure your system meets the requirements for your operating system.

- Close any other programs, including screen savers and virus protection software, and install your product software again.
- In Windows, make sure your product is selected as the default printer and the correct port is shown in the printer properties.
- If you see any error message or your software does not install correctly in Windows, you may not have software installation privileges. Contact your System Administrator.

Parent topic: [Solving Setup Problems](#)

USB Connection Problems

If you used a USB cable to connect to a computer that has multiple peripherals, make sure the computer is grounded. Otherwise, you may feel a slight electric shock when touching your product.

Parent topic: [Solving Setup Problems](#)

Solving Network Problems

Check these solutions if you have problems setting up or using your product on a network.

Note: Breakdown or repair of this product may cause loss of network data and settings. Epson is not responsible for backing up or recovering data and settings during or after the warranty period. We recommend that you make your own backup or print out your network data and settings.

[Product Cannot Connect to a Wireless Router or Access Point](#)

[Network Software Cannot Find Product on a Network](#)

[Product Does Not Appear in Mac Printer Window](#)

[Cannot Print Over a Network](#)

Parent topic: [Solving Problems](#)

Product Cannot Connect to a Wireless Router or Access Point

If your product has trouble finding or connecting to a wireless router or access point, try these solutions:

- If you are connecting the product via Wi-Fi Protected Setup (WPS) and the Wi-Fi icon on your product's LCD screen is not lit or does not appear, make sure you select one of the WPS options from the product control panel within 2 minutes of pressing the WPS button on your router.
- Make sure to place your product within contact range of your 2.4 GHz router or access point. Avoid placing your product near a microwave oven, 2.4 GHz cordless phone, or large metal object, such as a filing cabinet.

Note: If you are using a 5 GHz wireless router, set the router to operate in dual band (2.4 GHz and 5 GHz) mode. If your router uses a single network name (SSID) for both the 2.4 GHz and 5 GHz band, give each band its own network name (SSID) instead, such as Home Network 2.4 GHz and Home Network 5 GHz. See your router documentation or contact your internet service provider for instructions.

- Verify that your router or access point is operating correctly by connecting to it from your computer or another device.
- You may need to disable the firewall and any anti-virus software on your wireless router or access point.
- Check to see if access restrictions, such as MAC address filtering, are set on the router or access point. If access restrictions are set, add your product's MAC address to your router's address list. To obtain your product's MAC address, check the network status on the LCD screen. Then follow the instructions in your router or access point documentation to add the address to the list.
- If your router or access point does not broadcast its network name (SSID), follow the instructions that came with your product to enter your wireless network name manually.
- If your router or access point has security enabled, determine the kind of security it is using and any required password or passphrase for connection. Then make sure to enter the exact WEP key or WPA passphrase correctly.
- Check if your computer is restricting the available wireless channels. If so, verify that your wireless access point is using one of the usable channels and change to a usable channel, if necessary.
- If you are using a Wi-Fi Direct connection that suddenly disconnects, the Wi-Fi direct password on your device may have been changed. If necessary, delete the existing **DIRECT-xxxxxxx** connection settings from your device and enter a new password. See your device documentation for instructions.
- If you connected your product to a Windows computer using Wi-Fi Direct and it automatically selected Access Point Mode, you may have trouble accessing a low-priority Internet connection. Check the network connection or adapter settings in the Windows Control Panel and set the **Internet metric** setting to **100** for your version of the Internet Protocol.

Parent topic: [Solving Network Problems](#)

Related tasks

[Viewing the Network Status](#)

[Selecting Wireless Network Settings from the Control Panel](#)

Network Software Cannot Find Product on a Network

If EpsonNet Setup cannot find your product on a network, try these solutions:

- Make sure your product is turned on and connected to your network. Verify connection using your product control panel.
- Check if your network name (SSID) contains non-ASCII characters. Your product cannot display non-ASCII characters.
- Make sure your product is not connected to a guest network.
- If necessary, reinstall your product software and try running EpsonNet Setup again:
 1. Reset your product's network settings to their factory defaults.
 2. **Windows only:** uninstall your product software.
 3. Initialize your router following the instructions in your router documentation.

Note: If you are reading these instructions online, you will lose your Internet connection when you initialize your router, so note the next step before initializing it.

4. Download your product software from the Epson website using the instructions on the *Start Here* sheet.
- If you have replaced your router, reinstall your product software to connect to the new router.

Note: If you are using a 5 GHz wireless router, set the router to operate in dual band (2.4 GHz and 5 GHz) mode. If your router uses a single network name (SSID) for both the 2.4 GHz and 5 GHz band, give each band its own network name (SSID) instead, such as Home Network 2.4 GHz and Home Network 5 GHz. See your router documentation or contact your internet service provider for instructions.

Parent topic: [Solving Network Problems](#)

Related concepts

[Uninstall Your Product Software](#)

Related tasks

[Viewing the Network Status](#)

[Printing a Network Connection Report](#)

Product Does Not Appear in Mac Printer Window

If your product does not appear in the Mac printer window, try these solutions:

- Turn your product off, wait 30 seconds, then turn it back on again.
- If you are connecting the product via Wi-Fi Protected Setup (WPS) and the Wi-Fi icon on your product's LCD screen is not lit, make sure you select one of the WPS options from the product control panel within 2 minutes of pressing the WPS button on your router.
- If you are connecting the product wirelessly via EpsonNet Setup and the Wi-Fi icon does not appear lit on your LCD screen, make sure your product software was installed correctly. If necessary, reinstall your software.

Note: If you are using a 5 GHz wireless router, set the router to operate in dual band (2.4 GHz and 5 GHz) mode. If your router uses a single network name (SSID) for both the 2.4 GHz and 5 GHz band, give each band its own network name (SSID) instead, such as Home Network 2.4 GHz and Home Network 5 GHz. See your router documentation or contact your internet service provider for instructions.

Parent topic: [Solving Network Problems](#)

Related concepts

[Uninstall Your Product Software](#)

Cannot Print Over a Network

If you cannot print over a network, try these solutions:

- Make sure that your product is turned on.
- Make sure you install your product's network software as described in your product documentation.
- Check your network status on the LCD screen and verify that the network settings are correct. If the network status is **Disconnected**, check any cable connections and turn your product off and then on again.
- If you are using TCP/IP, make sure the product's IP address is set correctly for your network. If your network does not assign IP addresses using DHCP, set the IP address manually.
- Make sure your computer and product are both using the same wireless network.
- If network printing is slow, check your network status on the LCD screen and confirm the signal strength. If it is poor, place your product closer to your router or access point. Avoid placing your product near a microwave oven, 2.4 GHz cordless phone, or large metal object, such as a filing cabinet.

Note: If you are using a 5 GHz wireless router, set the router to operate in dual band (2.4 GHz and 5 GHz) mode. If your router uses a single network name (SSID) for both the 2.4 GHz and 5 GHz band, give each band its own network name (SSID) instead, such as Home Network 2.4 GHz and Home Network 5 GHz. See your router documentation or contact your internet service provider for instructions.

- Check to see if your wireless router or access point has an enabled Privacy Separator function that is preventing printing from a device over the network. See your router or access point documentation for instructions on disabling the Privacy Separator function.

Parent topic: [Solving Network Problems](#)

Related tasks

[Viewing the Network Status](#)

[Printing a Network Connection Report](#)

Solving Paper Problems

Check these sections if you have problems using paper with your product.

[Paper Feeding Problems](#)

[Paper Jam Problems Inside the Product](#)

[Paper Ejection Problems](#)

Parent topic: [Solving Problems](#)

Paper Feeding Problems

If you have problems feeding paper, try these solutions:

- If paper does not feed for printing, remove it. Then reload it in the rear paper feed against the left side. Slide the edge guide against the edge of the paper, making sure that the paper stack is not above the arrow mark on the edge guide.
- If multiple pages feed at once, remove the paper, fan the edges to separate the sheets, and reload it.
- If paper jams when you print on both sides of the paper, try loading fewer sheets.
- Make sure your paper meets the specifications for your product.
- Make sure the paper size and paper type settings on the control panel are correct.
- Try cleaning the paper path.
- For best results, follow these guidelines:
 - Use new, smooth, high-quality paper that is not curled, creased, old, too thin, or too thick.

- Load paper in the rear paper feed printable side up.
- Follow any special loading instructions that came with the paper.

Parent topic: [Solving Paper Problems](#)

Related references

[Paper Specifications](#)

[Paper or Media Type Settings - Product Software](#)

Related tasks

[Loading Paper in the Paper Feed Slot](#)

[Cleaning the Paper Path](#)

Paper Jam Problems Inside the Product

If paper has jammed inside the product, follow the steps below to clear the jam.

1. Cancel the print job, if necessary.
2. Remove any jammed paper from the rear paper feed slot.

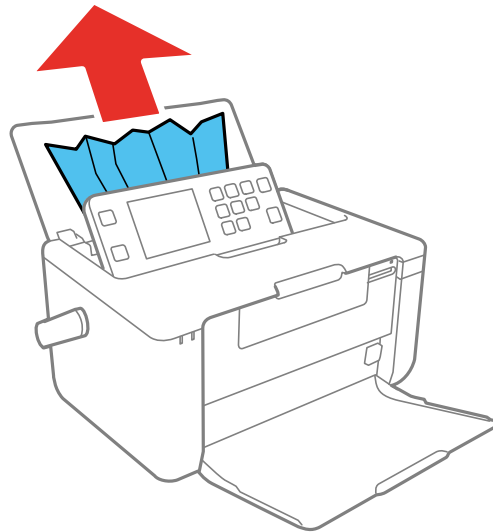

3. If necessary, carefully pull out any jammed paper from the front.

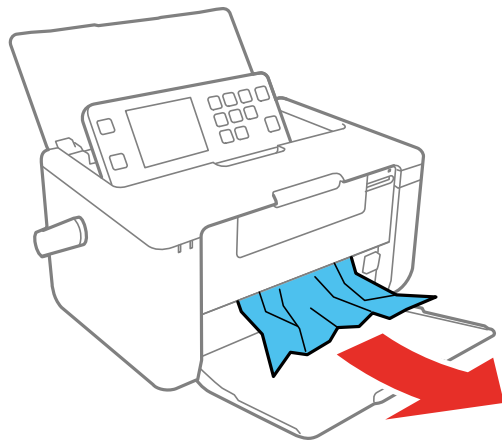

4. Open the printer cover.

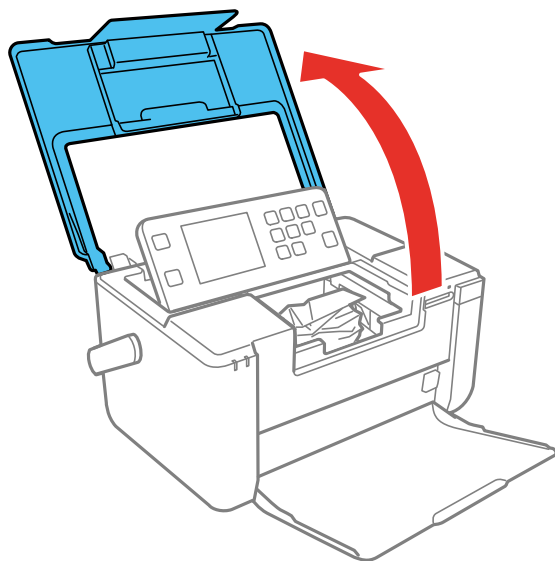

5. Carefully remove any jammed paper.

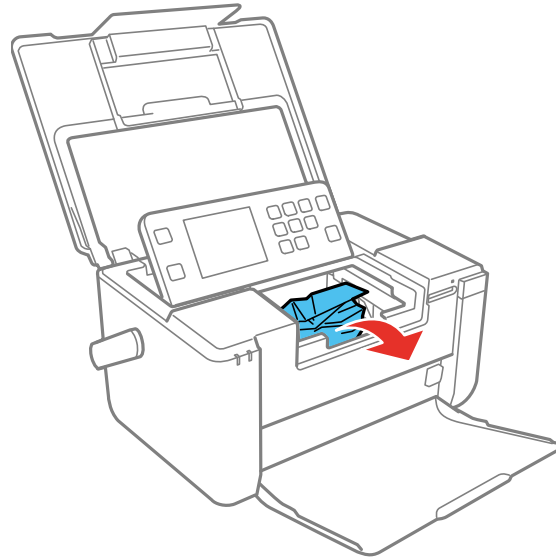

Caution: Do not touch the translucent part or flat white cable inside the product.

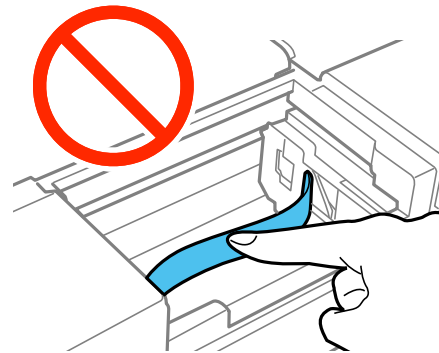
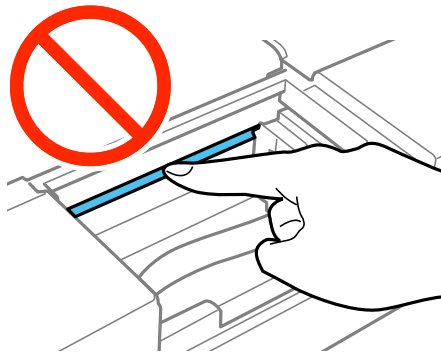

6. Close the printer cover.

7. Follow the prompts on the LCD screen to clear any error messages.

Parent topic: [Solving Paper Problems](#)

Paper Ejection Problems

If you have problems with paper ejecting properly, try these solutions:

- If paper does not eject fully, you may have set the wrong paper size. Cancel printing to eject the paper. Select the correct paper size when you reprint.
- If paper is wrinkled when it ejects, it may be damp or too thin. Load new paper and be sure to select the correct paper type setting when you reprint.

Parent topic: [Solving Paper Problems](#)

Related references

[Paper or Media Type Settings - Product Software](#)

Related tasks

[Loading Paper in the Paper Feed Slot](#)

Solving Problems Printing from a Computer

Check these sections if you have problems while printing from your computer.

Note: When printing using AirPrint, the available print settings are different from those covered in this manual. See the Apple website for details.

[Nothing Prints](#)

[Product Icon Does Not Appear in Windows Taskbar](#)

[Printing is Slow](#)

Parent topic: [Solving Problems](#)

Nothing Prints

If you have sent a print job and nothing prints, try these solutions:

- Make sure your product is turned on.
- Make sure any interface cables are connected securely at both ends.
- If you connected your product to a USB hub, make sure it is a first-tier hub. If it still does not print, connect your product directly to your computer instead of the hub.
- Run a product check to see if a test page prints. If the test page prints, check to see if your product software is installed correctly.

- If you are printing a large image, the computer may not have enough memory. Print the image at a lower resolution or a smaller file size.
- In Windows, click **Print Queue** on the Maintenance tab in the printer settings window and check for the following:
 - Check for any stalled or paused print jobs. Cancel or unpause any jobs as necessary.
 - Open the **Printer** menu and make sure the product is not offline.
 - Open the **Printer** menu and set the product as the default printer, if necessary.
- With a Mac, select **System Preferences** from the Apple menu or Dock, select **Print & Scan** or **Printers & Scanners**, then double-click your printer icon. Check to see if any jobs are paused. Cancel or resume any jobs as necessary.
- If you are using AirPrint, make sure AirPrint is enabled with the correct settings using Web Config.

Parent topic: [Solving Problems Printing from a Computer](#)



Related tasks

[Running a Product Check](#)

[Accessing the Web Config Utility](#)

Product Icon Does Not Appear in Windows Taskbar

If you do not see your product icon in the Windows taskbar, first try restarting your computer. If that does not work, try this solution:

1. Do one of the following:
 - **Windows 10:** Right-click  and select **Control Panel > Hardware and Sound > Devices and Printers**.
 - **Windows 8.x:** Navigate to the **Apps** screen and select **Control Panel > Hardware and Sound > Devices and Printers**.
 - **Windows 7:** Click  and select **Devices and Printers**.
 - **Windows Vista:** Click , select **Control Panel**, and click **Printer** under **Hardware and Sound**.
 - **Windows XP:** Click **Start** and select **Printers and Faxes**. (Or open the **Control Panel**, select **Printers and Other Hardware**, if necessary, and **Printers and Faxes**.)
2. Right-click your product name, select **Printing Preferences**, and select your product name again if necessary.
3. Click the **Maintenance** tab.

4. Click the **Extended Settings** button.
5. Select **Enable EPSON Status Monitor 3** and click **OK**.
6. Click the **Monitoring Preferences** button.
7. Click the checkbox for the option that adds the shortcut icon to the taskbar.
8. Click **OK** to close the open program windows.

Parent topic: [Solving Problems Printing from a Computer](#)

Printing is Slow

If printing becomes slow, try these solutions:

- Make sure your system meets the requirements for your operating system. If you are printing a high-resolution image, you may need more than the minimum requirements. If necessary, increase your system's memory.
- If you are using Windows 7, close the **Devices and Printers** window before you print.
- On a Mac, make sure you download and install the Epson printer driver.
- Clear space on your hard drive or run a defragmentation utility to free up existing space.
- Close any programs you are not using when you print.
- If your product is connected to a USB hub, connect it directly to your computer instead.
- If printing becomes slower after printing continuously for a long time, the product may have automatically slowed down to protect the print mechanism from overheating or becoming damaged. Let the product rest with the power on for 30 minutes, then try printing again.
- If you are printing over a wireless network, factors such as interference, network traffic, or weak signal strength may affect your printing speed.

For the fastest printing, select the following settings in your product software:

- Make sure the paper type setting matches the type of paper you loaded.
- Turn on any high speed settings in your product software.
- Select a lower print quality setting.
- **Windows:** Click the **Maintenance** or **Utility** tab, select **Extended Settings** or **Speed and Progress**, and select the following settings:
 - **Always Spool RAW Datatype**
 - **Page Rendering Mode**

- **Print as Bitmap**

Parent topic: [Solving Problems Printing from a Computer](#)

Related references

[Windows System Requirements](#)

[Mac System Requirements](#)

Solving Page Layout and Content Problems

Check these sections if you have problems with the layout or content of your printed pages.

Note: When printing using AirPrint, the available print settings are different from those covered in this manual. See the Apple website for details.

[Inverted Image](#)

[Too Many Copies Print](#)

[Blank Pages Print](#)

[Incorrect Margins on Printout](#)

[Border Appears on Borderless Prints](#)

[Incorrect Characters Print](#)

[Incorrect Image Size or Position](#)

[Slanted Printout](#)

Parent topic: [Solving Problems](#)

Inverted Image

If your printed image is inverted unexpectedly, try these solutions:

- Turn off any mirror or inversion settings in your printing application.
- Turn off the **Mirror Image**, **Flip horizontally**, or **Reverse page orientation** settings in your printer software. (This option has different names, depending on your operating system version.)

Parent topic: [Solving Page Layout and Content Problems](#)

Related references

[Image Options and Additional Settings - Windows](#)

[Print Options - Mac](#)

Too Many Copies Print

Make sure that the **Copies** setting in your printing program or printer software is not set for multiple copies.

Parent topic: [Solving Page Layout and Content Problems](#)

Blank Pages Print

If blank pages print unexpectedly, try these solutions:

- Make sure you selected the correct paper size settings in your printing program and printer software.
- If a blank page exists in a document you are printing and you want to skip printing it, select the **Skip Blank Page** setting in your printer software, if available.
- Run a print head nozzle check to see if any of the nozzles are clogged. Then clean the print head, if necessary.
- Make sure your product is selected as the printer in your printing program.

Parent topic: [Solving Page Layout and Content Problems](#)

Related concepts

[Print Head Nozzle Check](#)

[Print Head Cleaning](#)

Incorrect Margins on Printout

If your printed page has incorrect margins, try these solutions:

- Make sure you selected the correct paper size settings in your printing program and printer software.
- Make sure you selected the correct margins for your paper size in your printing program.
- Make sure your paper is positioned correctly for feeding into the printer.

You can use the preview option in your printer software to check your margins before you print.

Parent topic: [Solving Page Layout and Content Problems](#)

Related tasks

[Selecting Basic Print Settings - Windows](#)

[Selecting Basic Print Settings - Mac](#)

Border Appears on Borderless Prints

If you see a border on borderless prints, try these solutions:

- Make sure you are printing on a compatible borderless paper type and size.

Note: For custom paper sizes, make sure you select a supported borderless page width.

- **Windows:** Make sure you selected the **Borderless** setting in your printer software.
- **Mac:** Make sure you selected the **Borderless** checkbox or a paper size with a **Borderless** option in your printer software.
- Adjust the **Expansion** setting to adjust the amount of image expansion on the edges of borderless prints.
- Make sure the image size and the paper size are set correctly; if the image is small, the enlargement may not be enough to cover the paper.

Parent topic: [Solving Page Layout and Content Problems](#)

Related references

[Borderless Paper Type Compatibility](#)

Related tasks

[Selecting Basic Print Settings - Windows](#)

[Selecting Page Setup Settings - Mac](#)

Incorrect Characters Print

If incorrect characters appear in your prints, try these solutions before reprinting:

- Make sure any cables are securely connected at both ends.
- In Windows, delete all jobs from the Windows Spooler. Click **Print Queue** on the Maintenance tab in the printer settings window, and cancel any stalled print jobs.
- If your product is connected to a USB hub, connect it directly to your computer instead.
- If your computer entered sleep mode the last time you printed, the next print job after your computer exits sleep mode may contain garbled characters. Print your document again.
- If incorrect characters still appear in your prints, try connecting your product using a different cable.

Parent topic: [Solving Page Layout and Content Problems](#)

Incorrect Image Size or Position

If your printed image is the wrong size or in the wrong position, try these solutions:

- Make sure you selected the correct paper size and layout settings in your printing program and printer software.
- Make sure you selected the correct paper size on the control panel.
- Make sure your paper is positioned correctly for feeding into the printer.

You can use the preview option in your printer software to check your margins before you print.

Parent topic: [Solving Page Layout and Content Problems](#)

Related tasks

[Loading Paper in the Paper Feed Slot](#)

Slanted Printout

If your printouts are slanted, try these solutions:

- Slide the edge guide against the edge of the paper.
- Select a higher print quality setting in your printer software.
- Turn off any high speed settings in your product software.
- Align the print head.
- Make sure the product is not printing while tilted or at an angle.

Parent topic: [Solving Page Layout and Content Problems](#)

Related concepts

[Print Head Alignment](#)

Related tasks

[Selecting Basic Print Settings - Windows](#)

[Selecting Basic Print Settings - Mac](#)

Solving Print Quality Problems

Check these sections if your printouts have problems with print quality, but your image looks fine on your computer screen.

Note: When printing using AirPrint, the available print settings are different from those covered in this manual. See the Apple website for details.

[White or Dark Lines in Printout](#)
[Blurry or Smearred Printout](#)
[Faint Printout or Printout Has Gaps](#)
[Grainy Printout](#)
[Incorrect Colors](#)

Parent topic: [Solving Problems](#)

White or Dark Lines in Printout

If you notice white or dark lines in your prints (also called banding), try these solutions before you reprint:

- Run a nozzle check to see if any of the print head nozzles are clogged. Then clean the print head, if necessary.
- Make sure the paper type setting matches the type of paper you loaded.
- Make sure you loaded the printable side of the paper correctly for your product.
- Turn off any high speed settings in your product software.
- Align the print head.
- You may need to replace the ink cartridge.

Parent topic: [Solving Print Quality Problems](#)

Related concepts

[Print Head Nozzle Check](#)

[Print Head Cleaning](#)

Related references

[Paper or Media Type Settings - Product Software](#)

[Paper Type Settings - Control Panel](#)

Blurry or Smearred Printout

If your printouts are blurry or smearred, try these solutions:

- Make sure your paper is not damp, curled, old, or loaded incorrectly in your product.
- Use a support sheet with special paper, or load special paper one sheet at a time.
- Make sure your paper meets the specifications for your product.
- Use Epson papers to ensure proper saturation and absorption of genuine Epson inks.
- Make sure the paper type setting in your product software matches the type of paper you loaded.

- Make sure you loaded the printable side of the paper correctly for your product.
- Remove each sheet from the output tray as it is printed.
- Avoid handling printouts on glossy paper right after printing to allow the ink to set.
- If you print on both sides of a sheet of paper, smudges may appear on the reverse side of heavily saturated or dark images. If one side of a sheet will contain a lighter image or text, print that side first. Make sure the ink has dried before reloading the paper to print on the other side.
- Run a nozzle check to see if any of the print head nozzles are clogged. Then clean the print head, if necessary.
- Align the print head.
- Clean the paper path.

Note: Your product will not operate properly while tilted at an angle. Place it on a flat, stable surface that extends beyond the base of the product in all directions.

Parent topic: [Solving Print Quality Problems](#)

Related concepts

[Print Head Nozzle Check](#)

[Print Head Alignment](#)

Related references

[Paper Specifications](#)

[Available Epson Papers](#)

[Paper or Media Type Settings - Product Software](#)

[Paper Type Settings - Control Panel](#)

Related tasks

[Loading Paper in the Paper Feed Slot](#)

[Cleaning the Paper Path](#)

Faint Printout or Printout Has Gaps

If your printouts are faint or have gaps, try these solutions:

- Run a nozzle check to see if any of the print head nozzles are clogged. Then clean the print head, if necessary.
- The ink cartridge may be old or low on ink, and you may need to replace it.

- Make sure the paper type setting matches the type of paper you loaded.
- Make sure your paper is not damp, curled, old, or loaded incorrectly in your product.
- Align the print head.
- Clean the paper path.

Parent topic: [Solving Print Quality Problems](#)

Related concepts

[Print Head Nozzle Check](#)

[Print Head Alignment](#)

Related references

[Paper or Media Type Settings - Product Software](#)

[Paper Type Settings - Control Panel](#)

Related tasks

[Cleaning the Paper Path](#)

Related topics

[Replacing the Ink Cartridge and Maintenance Box](#)

Grainy Printout

If your printouts are grainy, try these solutions:

- Make sure you loaded the printable side of the paper correctly for your product.
- Select a higher print quality setting and turn off any high speed settings in your product software.
- Run a nozzle check to see if any of the print head nozzles are clogged. Then clean the print head, if necessary.
- Align the print head.
- You may need to increase the image resolution or print a smaller size; see your software documentation.

Note: Images from the Internet may be low resolution and not result in a high quality printout.

- If you enlarged the image size in an image-editing program, you need to increase the image resolution setting to retain a high image quality. Increase the image resolution by the same amount you increase the image size. For example, if the image resolution is 300 dpi (dots per inch) and you will double the image size for printing, change the resolution setting to 600 dpi.

Note: Higher resolution settings result in larger file sizes, which take longer to process and print. Consider the limitations of your computer system when selecting a resolution, and select the lowest possible resolution that produces acceptable quality to keep file sizes manageable.

Parent topic: [Solving Print Quality Problems](#)

Related concepts

[Print Head Nozzle Check](#)

[Print Head Alignment](#)

Related tasks

[Loading Paper in the Paper Feed Slot](#)

[Selecting Basic Print Settings - Windows](#)

[Selecting Basic Print Settings - Mac](#)

Incorrect Colors

If your printouts have incorrect colors, try these solutions:

- Make sure the paper type setting matches the paper you loaded.
- Make sure the **Black/Grayscale** or **Grayscale** setting is not selected in your printer software.
- Run a nozzle check to see if any of the print head nozzles are clogged. Then clean the print head, if necessary.
- The ink cartridge may be old or low on ink, and you may need to replace it.
- After you print, the colors in your printout need time to set as the ink dries. During this time, the colors may look different than you expect. To speed up drying time, do not stack your printouts on top of each other.
- Your printed colors can never exactly match your on-screen colors. However, you can use a color management system to get as close as possible. Try using the color management options in your printer software.
- For best results, use genuine Epson ink and paper.

Parent topic: [Solving Print Quality Problems](#)

Related concepts

[Print Head Nozzle Check](#)

Related references

[Paper or Media Type Settings - Product Software](#)

[Paper Type Settings - Control Panel](#)

Related tasks

[Selecting Basic Print Settings - Windows](#)

[Selecting Page Setup Settings - Mac](#)

Related topics

[Replacing the Ink Cartridge and Maintenance Box](#)

Solving Memory Card Problems

Check these solutions if you have problems using memory cards with your product.

[Memory Card Does Not Fit Into a Slot](#)

[Cannot View or Print Photos from a Memory Card or Device](#)

[Cannot Transfer Photos to or from a Memory Card or Device](#)

Parent topic: [Solving Problems](#)

Memory Card Does Not Fit Into a Slot

If a memory card does not fit properly in a slot, do not force it in. You may need to use an adapter with your memory card.

Parent topic: [Solving Memory Card Problems](#)

Related references

[Memory Card Specifications](#)

Cannot View or Print Photos from a Memory Card or Device

If you cannot view or print photos from a memory card or USB device inserted in your product, try these solutions:

- Make sure your memory card or device is compatible with the product.
- Make sure the files on your memory card or device are in the correct format.
- If you have too many photos on your memory card or device, you may not see all the photos you expect or may be prompted to select a group of photos by date. Reduce the number of photos on your card or select one group of photos at a time. Check the specifications for the maximum number of photos.

Parent topic: [Solving Memory Card Problems](#)

Related references

[Memory Card Specifications](#)

Cannot Transfer Photos to or from a Memory Card or Device

If you have problems transferring photos to or from a memory card, try these solutions:

- Make sure your memory card or device is compatible with the product.
- Make sure your product is set up wirelessly and connected to the same network as your computer.
- If you are transferring photos to a memory card, check the memory card's write-protect tab to make sure it is set to allow writing to the card.
- Make sure that the file sharing setting for your product is set correctly.

Parent topic: [Solving Memory Card Problems](#)

Related references

[Memory Card Specifications](#)

Related topics

[Wi-Fi Networking](#)

Uninstall Your Product Software

If you have a problem that requires you to uninstall and re-install your software, follow the instructions for your operating system.

[Uninstalling Printing Software - Windows](#)

[Uninstalling Product Software - Mac](#)

Parent topic: [Solving Problems](#)

Uninstalling Printing Software - Windows

You can uninstall and then re-install your printer software to solve certain problems.

1. Turn off the product.
2. Disconnect any interface cables.
3. Do one of the following:
 - **Windows 10:** Right-click  and select **Control Panel > Programs > Programs and Features**. Select the uninstall option for your Epson product, then select **Uninstall/Change**.

Note: If you see a **User Account Control** window, click **Yes** or **Continue**.

Select your product again, if necessary, then select **OK**, and click **Yes** to confirm the uninstallation.

- **Windows 8.x:** Navigate to the **Apps** screen and select **Control Panel > Programs > Programs and Features**. Select the uninstall option for your Epson product, then select **Uninstall/Change**.

Note: If you see a **User Account Control** window, click **Yes** or **Continue**.

In the next window, select your product, if necessary, and click **OK**. Then follow any on-screen instructions.

- **Windows (other versions):** Click  or **Start**, and select **All Programs** or **Programs**. Select **Epson**, select your product, then click **EPSON Printer Software Uninstall**.

Note: If you see a **User Account Control** window, click **Yes** or **Continue**.

In the next window, select your product, if necessary, and click **OK**. Then follow any on-screen instructions.

4. Restart your computer, then re-install your software.

Note: If you find that re-installing your product software does not solve a problem, contact Epson.

Parent topic: [Uninstall Your Product Software](#)

Uninstalling Product Software - Mac

In most cases, you do not need to uninstall your product software before re-installing it. However, you can download the Uninstaller utility from the Epson support website to uninstall your product software as described here.

Note: If you find that re-installing your product software does not solve a problem, contact Epson.

1. To download the Uninstaller utility, visit epson.com.jm/support and select your product.
2. Click **Downloads**.
3. Select your operating system, click **Utilities**, locate the Uninstaller utility, and click **Download**.
4. Run the file you downloaded.
5. Double-click the **Uninstaller** icon.

6. In the Epson Uninstaller screen, select the checkbox for each software program you want to uninstall.
7. Click **Uninstall**.
8. Follow the on-screen instructions to uninstall the software.
9. Reinstall your product software.

Note: If you uninstall the printer driver and your product name remains in the **Print & Fax, Print & Scan,** or **Printers & Scanners** window, select your product name and click the – (remove) icon to remove it.

Parent topic: [Uninstall Your Product Software](#)

Where to Get Help

If you need additional help with your Epson product, contact Epson.

Epson provides these technical support services:

Internet Support

Visit Epson's support website at epson.com.jm/support for solutions to common problems. You can download drivers and documentation, get FAQs and troubleshooting advice, or e-mail Epson with your questions.

Speak to a Support Representative

Before you call Epson for support, please have the following information ready:

- Product name
- Product serial number (located on a label on the product)
- Proof of purchase (such as a store receipt) and date of purchase
- Computer configuration
- Description of the problem

Then call:

Country	Telephone
Argentina	(54 11) 5167-0300 0800-288-37766

Country	Telephone
Bolivia*	800-100-116
Brazil	State capitals and metropolitan areas: 3004-6627 Other areas: 0800-377-6627 / 0800-EPSONBR
Chile	(56 2) 2484-3400
Colombia	Bogota: (57 1) 523-5000 Other cities: 018000-915235
Costa Rica	800-377-6627
Dominican Republic*	1-888-760-0068
Ecuador*	1-800-000-044
El Salvador*	800-6570
Guatemala*	1-800-835-0358
Honduras**	800-0122 Code: 8320
Mexico	Mexico City: (52 55) 1323-2052 Other cities: 01-800-087-1080
Nicaragua*	00-1-800-226-0368
Panama*	00-800-052-1376
Paraguay	009-800-521-0019
Peru	Lima: (51 1) 418-0210 Other cities: 0800-10126
Uruguay	00040-5210067
Venezuela	(58 212) 240-1111

* Contact your local phone company to call this toll-free number from a mobile phone.

** Dial first 7 digits, wait for a message, then enter code.

If your country does not appear in the list, contact the sales office in the nearest country. Toll or long distance charges may apply.

Purchase Supplies and Accessories

You can purchase genuine Epson ink and paper from an Epson authorized reseller. To find the nearest reseller, visit epson.com.jm or call your nearest Epson sales office.

Parent topic: [Solving Problems](#)

Technical Specifications

These sections list the technical specifications for your product.

[Windows System Requirements](#)

[Mac System Requirements](#)

[Paper Specifications](#)

[Printable Area Specifications](#)

[Ink Cartridge Specifications](#)

[Memory Card Specifications](#)

[External USB Device Specifications](#)

[Dimension Specifications](#)

[Electrical Specifications](#)

[Environmental Specifications](#)

[Interface Specifications](#)

[Network Interface Specifications](#)

[Safety and Approvals Specifications](#)

Windows System Requirements

To use your product and its software, your computer should use one of these Microsoft operating systems:

- Windows 10
- Windows 8.x
- Windows 7
- Windows Vista
- Windows XP Professional x64 Edition
- Windows XP SP3

Note: For the latest product software available for your operating system, visit the Epson support site at epson.com.jm/support, select your product, and select **Downloads**.

Parent topic: [Technical Specifications](#)

Mac System Requirements

To use your product and its software, your Mac should use one of these operating systems:

- macOS 10.12.x
- OS X 10.11.x
- OS X 10.10.x
- OS X 10.9.x
- OS X 10.8.x
- OS X 10.7.x
- OS X 10.6.8

Note: For the latest product software available for your operating system, visit the Epson support site at epson.com/jm/support, select your product, and select **Downloads**.

Parent topic: [Technical Specifications](#)

Paper Specifications

Note: Since the quality of any particular brand or type of paper may be changed by the manufacturer at any time, Epson cannot guarantee the quality of any non-Epson brand or type of paper. Always test a sample of paper stock before purchasing large quantities or printing large jobs.

Single-sheets

Size	A5 (5.8 × 8.2 inches [148 × 210 mm]) A6 (4.1 × 5.8 inches [105 × 148 mm]) 4 × 6 inches (102 × 152 mm) 5 × 7 inches (127 × 178 mm) 3.5 × 5 inches (89 × 127 mm) 16:9 wide (4 × 7.1 inches [102 × 181 mm])
Paper types	Plain paper and paper distributed by Epson
Thickness	0.002 inch (0.05 mm) to 0.02 inch (0.6 mm)

Weight 17 lb (64 g/m²) to 24 lb (90 g/m²)

Envelopes

Size No. 10 (4.1 × 9.5 inches [105 × 241 mm])

Paper types Plain bond paper

Weight 20 lb (75 g/m²) to 24 lb (90 g/m²)

Parent topic: [Technical Specifications](#)

Printable Area Specifications

Note: When printing borderless, quality may decline in the expanded printable area.

Single sheets - normal printing

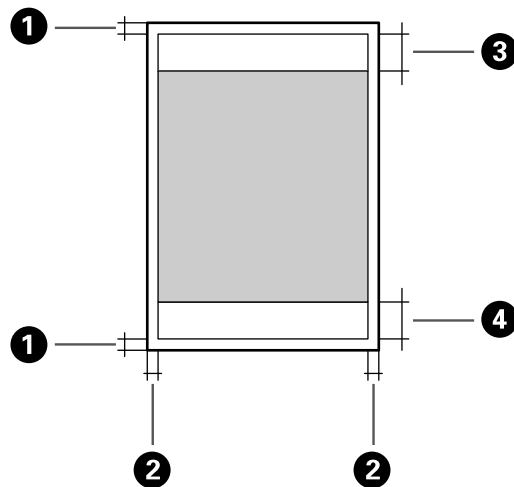

1 Margin: 0.12 inch (3.0 mm) minimum

2 A5 (5.8 × 8.2 inches [148 × 210 mm]) paper: 0.12 inch (3.0 mm) minimum

Paper smaller than A5 (5.8 × 8.2 inches [148 × 210 mm]): 0.39 inch (10.0 mm) minimum

- 3 Reduced print quality area (top): 1.46 inch (37.0 mm) minimum
- 4 Reduced print quality area (bottom): 1.54 inch (39 mm) minimum

Single sheets - borderless printing

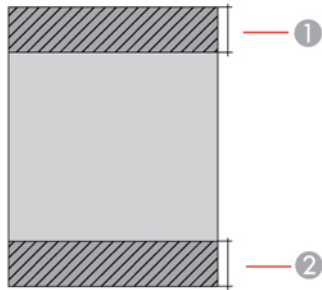

- 1 Reduced print quality area (top): 1.57 inch (40.0 mm) minimum
- 2 Reduced print quality area (bottom): 1.65 inch (42 mm) minimum

Envelopes

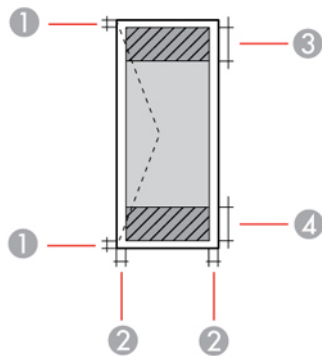

- 1 Left and right margins: 0.12 inch (3.0 mm) minimum
- 2 Top and bottom margins: 0.20 inch (5.0 mm) minimum
- 3 Reduced print quality area (right): 0.71 inch (18.0 mm) minimum

4 Reduced print quality area (left): 1.46 inch (37.0 mm) minimum

Parent topic: [Technical Specifications](#)

Ink Cartridge Specifications

Note: This product was originally designed to work with genuine Epson ink cartridges. Your product may not function properly if you use other types of cartridges or if you use refilled cartridges.

The included cartridge must be used for printer setup and is not for resale. For more information, see latin.epson.com/infocartucho (website available in Spanish only). Yields vary considerably based on images printed, print settings, paper type, frequency of use, and temperature. For print quality, a variable amount of ink remains in the cartridge after the "replace cartridge" indicator comes on.

Color	Cyan, Magenta, Yellow, Black
Cartridge life	Opened package: 6 months Unopened package: do not use if the date on the package has expired
Temperature	Storage: -22 to 104 °F (-30 to 40 °C) 1 month at 104 °F (40 °C) Ink freezes at 3.2 °F (-16 °C) Ink thaws and is usable after 3 hours at 77 °F (25 °C)

Note: For best printing results, use up a cartridge within 6 months of opening the package.

Parent topic: [Technical Specifications](#)

Memory Card Specifications

Note: Cards marked with an asterisk (*) require an adapter; consult your adapter documentation for details on using it.

Compatible types	SD: 2GB SDHC: 32GB SDXC: 64GB miniSD*: 2GB miniSDHC*: 32GB microSD*: 2GB microSDHC*: 32GB microSDXC*: 64GB
Media format DCF	JPEG with the Exif Version 2.3 standard taken by digital cameras DCF (Design rule for Camera File system) version 1.0 or 2.0 compliant
Voltage requirements	3.3 V type, dual voltage type (3.3 V and 5 V) type Supply voltage: 3.3 V (5 V memory cards not supported) Maximum current: 200 mA

Note: Photo data stored in the built-in memory of a digital camera is not supported.

Parent topic: [Technical Specifications](#)

External USB Device Specifications

Do not use devices with the following requirements:

- Dedicated driver
- Security settings, such as password or encryption, etc.
- Built-in USB hub

Note: Use only external storage devices with independent AC power sources. External storage devices that are powered via USB are not recommended. Epson cannot guarantee the operation of externally connected devices.

CD-ROM/CD-R drive	700MB maximum capacity CD-RW is not supported
--------------------------	--

DVD-ROM/DVD-R drive	4.7GB maximum capacity DVD+R, DVD±RW, DVD-RAM, and Blu-ray Disc are not supported
Magneto-optical drive	1.3GB
Hard disk and USB flash drives	2TB Formatted in FAT, FAT32, or exFAT.

Parent topic: [Technical Specifications](#)

Dimension Specifications

Height	Stored: 5.4 inches (137 mm) Printing: 8.3 inches (210 mm)
Width	Stored: 10.4 inches (265 mm) Printing: 10.4 inches (265 mm)
Depth	Stored: 7.7 inches (196 mm) Printing: 13.6 inches (345 mm)
Weight (without the ink cartridge and AC adapter)	5.1 lb (2.3 kg)

Parent topic: [Technical Specifications](#)

Electrical Specifications

AC Adapter

AC adapter model	A461H and A462E
Input	A461H: AC 100–240 V, 1 A, 50–60 Hz A462E: AC 220–240 V, 1 A, 50–60 Hz
Output	DC 24 V, 1 A

Printer Using the AC Adapter

Rated DC input voltage	DC 24 V
Rated DC input current	Printing: 0.7 A Charging battery: 1.0 A
Power consumption (USB Connection)	Not charging battery: Printing: Approximately 12 W (ISO/IEC24712) Ready mode: Approximately 5.0 W Sleep mode: Approximately 1.0 W Power off mode: Approximately 0.2 W Charging battery: Printing: Approximately 12 W (ISO/IEC24712) Ready mode: Approximately 24 W Sleep mode: Approximately 22 W Power off mode: Approximately 22 W

Battery

Type	Li-ion
Rated power supply voltage	14.8 V
Capacity of current	1730 mAh
Continuous print time	Approximately 2 hours when printing photos in this size with a fully-charged battery at an environmental temperature between 68 to 86 °F (20 to 30 °C): 4 × 6 inches (102 × 152 mm)
Continuous number of prints	Approximately 170 sheets when printing photos in this size with a fully-charged battery at an environmental temperature between 68 to 86 °F (20 to 30 °C): 4 × 6 inches (102 × 152 mm)
Charging time	Approximately 5.0 hours when charging the battery with the power off at an environmental temperature between 68 to 86 °F (20 to 30 °C)

Parent topic: [Technical Specifications](#)

Environmental Specifications

Temperature	Operating: 32 to 104 °F (0 to 40 °C) Storage: -4 to 104 °F (-20 to 40 °C) 1 month at 104 °F (40 °C)
Humidity (without condensation)	Operating: 20 to 80% RH Storage: 5 to 85% RH

Parent topic: [Technical Specifications](#)

Interface Specifications

Interface type	Hi-Speed USB (Device Class for computers) Hi-Speed USB (for external USB and PictBridge device)
-----------------------	--

Note: Epson cannot guarantee the operation of externally connected devices.

Parent topic: [Technical Specifications](#)

Network Interface Specifications

Wireless LAN standard	IEEE 802.11 b/g/n
Wireless security	WEP (64/128 bit) WPA2-PSK (AES); complies with WPA2 with support for WPA/WPA2 Personal
Frequency band	2.4 GHz
Communication mode	Infrastructure mode Wi-Fi Direct (not supported for IEEE 802.11b)

Note: Wireless LAN standard complies with either IEEE 802.11 b/g or IEEE 802.11 b/g/n, depending on purchase location.

Parent topic: [Technical Specifications](#)

Safety and Approvals Specifications

United States

Safety: UL60950-1

EMC: FCC part 15 Subpart B class B

Canada

Safety: CAN/CSA C22.2 No. 60950-1

EMC: CAN/CSA-CEI/IEC CISPR 22 Class B

This equipment contains the following wireless module:

- Manufacturer: Askey Computer Corporation
- Type: WLU6320-D69 (RoHS)

This product conforms to Part 15 of FCC Rules and RSS-210 of the IC Rules. Epson cannot accept responsibility for any failure to satisfy the protection requirements resulting from a non-recommended modification of the product. Operation is subject to the following two conditions: (1) this device may not cause harmful interference, and (2) this device must accept any interference received, including interference that may cause undesired operation of the device.

To prevent radio interference to the licensed service, this device is intended to be operated indoors and away from windows to provide maximum shielding. Equipment (or its transmit antenna) that is installed outdoors is subject to licensing.

This equipment complies with FCC/IC radiation exposure limits set forth for an uncontrolled environment and meets the FCC radio frequency (RF) Exposure Guidelines in Supplement C to OET65 and RSS-102 of the IC radio frequency (RF) Exposure rules. This equipment should be installed and operated so that the radiator is kept at least 7.9 inches (20 cm) or more away from a person's body (excluding extremities: hands, wrists, feet and ankles).

Parent topic: [Technical Specifications](#)

Notices

Check these sections for important notices about your product.

[FCC Compliance Statement](#)

[Trademarks](#)

[Copyright Notice](#)

FCC Compliance Statement

For United States Users

This equipment has been tested and found to comply with the limits for a Class B digital device, pursuant to Part 15 of the FCC Rules. These limits are designed to provide reasonable protection against harmful interference in a residential installation. This equipment generates, uses, and can radiate radio frequency energy and, if not installed and used in accordance with the instructions, may cause harmful interference to radio or television reception. However, there is no guarantee that interference will not occur in a particular installation. If this equipment does cause interference to radio and television reception, which can be determined by turning the equipment off and on, the user is encouraged to try to correct the interference by one or more of the following measures:

- Reorient or relocate the receiving antenna.
- Increase the separation between the equipment and receiver.
- Connect the equipment into an outlet on a circuit different from that to which the receiver is connected.
- Consult the dealer or an experienced radio/TV technician for help.

WARNING

The connection of a non-shielded equipment interface cable to this equipment will invalidate the FCC Certification or Declaration of this device and may cause interference levels which exceed the limits established by the FCC for this equipment. It is the responsibility of the user to obtain and use a shielded equipment interface cable with this device. If this equipment has more than one interface connector, do not leave cables connected to unused interfaces. Changes or modifications not expressly approved by the manufacturer could void the user's authority to operate the equipment.

For Canadian Users

CAN ICES-3(B)/NMB-3(B)

Parent topic: [Notices](#)

Trademarks

EPSON® is a registered trademark, EPSON Exceed Your Vision is a registered logomark, and Epson Connect™, Epson iPrint™ and Remote Print™ are trademarks of Seiko Epson Corporation.

Apple, App Store, AirPrint, iPad, iPhone, iPod touch, Mac, OS X, and macOS are trademarks of Apple Inc., registered in the U.S. and other countries.

Google® is a registered trademark and Android™, Chromebook™, Gmail™, Google Chrome™, Google Cloud Print™, Google Drive™, Google Photos™, and Google Play™ are trademarks of Google Inc.

Wi-Fi Direct® is a registered trademark of Wi-Fi Alliance®.

General Notice: Other product names used herein are for identification purposes only and may be trademarks of their respective owners. Epson disclaims any and all rights in those marks.



Parent topic: [Notices](#)

Copyright Notice

All rights reserved. No part of this publication may be reproduced, stored in a retrieval system, or transmitted in any form or by any means, electronic, mechanical, photocopying, recording, or otherwise, without the prior written permission of Seiko Epson Corporation. The information contained herein is designed only for use with this Epson product. Epson is not responsible for any use of this information as applied to other products.

Neither Seiko Epson Corporation nor its affiliates shall be liable to the purchaser of this product or third parties for damages, losses, costs, or expenses incurred by purchaser or third parties as a result of: accident, misuse, or abuse of this product or unauthorized modifications, repairs, or alterations to this product, or (excluding the U.S.) failure to strictly comply with Seiko Epson Corporation's operating and maintenance instructions.

Seiko Epson Corporation shall not be liable for any damages or problems arising from the use of any options or any consumable products other than those designated as Original Epson Products or Epson Approved Products by Seiko Epson Corporation.

Seiko Epson Corporation shall not be held liable for any damage resulting from electromagnetic interference that occurs from the use of any interface cables other than those designated as Epson approved Products by Seiko Epson Corporation.

This information is subject to change without notice.

[A Note Concerning Responsible Use of Copyrighted Materials](#)
[Default Delay Times for Power Management for Epson Products](#)
[Copyright Attribution](#)

Parent topic: [Notices](#)

A Note Concerning Responsible Use of Copyrighted Materials

Epson encourages each user to be responsible and respectful of the copyright laws when using any Epson product. While some countries' laws permit limited copying or reuse of copyrighted material in certain circumstances, those circumstances may not be as broad as some people assume. Contact your legal advisor for any questions regarding copyright law.

Parent topic: [Copyright Notice](#)

Default Delay Times for Power Management for Epson Products

This product will enter sleep mode after a period of nonuse. This is to ensure that the product meets Energy Star standards of energy efficiency. More energy savings can be achieved by setting the time to sleep to a shorter interval.

Parent topic: [Copyright Notice](#)

Copyright Attribution

© 2017 Epson America, Inc.

3/17

CPD-53210

Parent topic: [Copyright Notice](#)