

MakerBot Sketch Sprint

User Manual

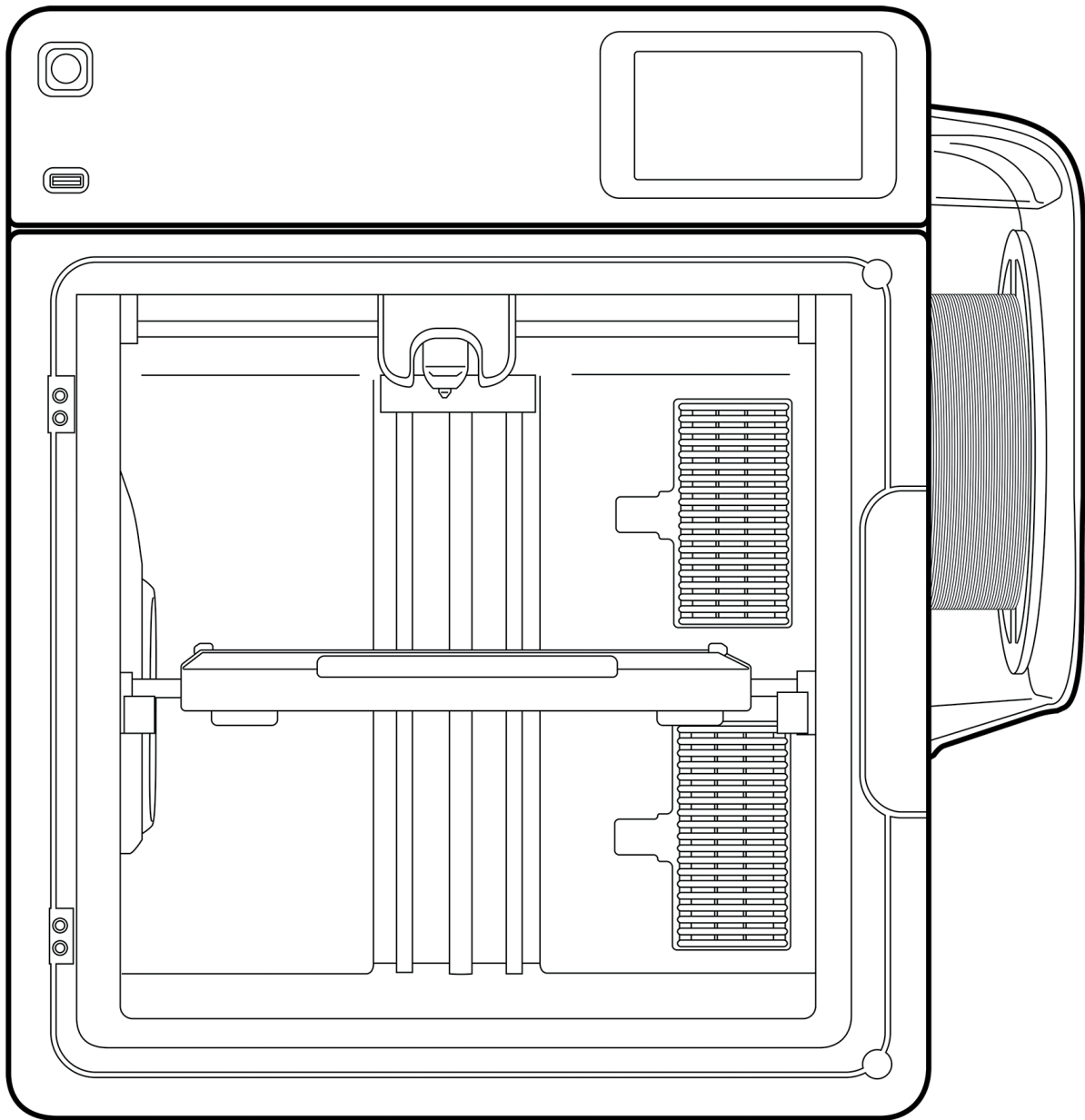

Legal notices

Limited warranty

The MakerBot Limited Warranty (available at makerbot.com/legal) applies to the MakerBot Sketch Sprint 3D Printer.

Overall provisions

All information in this user manual (“**Manual**”) is subject to change at any time without notice and is provided for convenience purposes only. MakerBot Industries, LLC and our respective affiliates and suppliers (“**MakerBot**”) reserves the right to modify or revise this Manual in its sole discretion and at any time and makes no commitment to provide any such changes, updates, enhancements, or other additions to this Manual in a timely manner or at all. Contact the MakerBot Support Team for up-to-date information. In order to protect MakerBot proprietary and confidential information and/or trade secrets, this manual may describe some aspects of MakerBot technology in generalized terms.

Disclaimers

MakerBot does not warrant the accuracy or completeness of the information, products, or services provided by or through this Manual and assumes no responsibility for any typographical, technical, or other inaccuracies in this Manual, which is provided “as is” and without any express or implied warranties of any kind, including warranties of merchantability, fitness for a particular purpose, or non-infringement of intellectual property. In connection with your use of this Manual, MakerBot shall not be liable to you for any damages whatsoever, be they direct, economic, commercial, special, consequential, incidental, exemplary, or indirect damages, even if MakerBot has been advised of the possibility of such damages, including without limitation, loss of business revenue or earnings, lost data, or lost profits. MakerBot assumes no responsibility, nor will be liable, for any damages to, or any viruses or malware that may infect, your computer, telecommunication equipment, or other property caused by or arising from your downloading of any information or materials related to this Manual. The foregoing exclusions do not apply to the extent prohibited by law; please refer to your local laws for any such prohibitions. MakerBot makes no warranties to those defined as “consumers” in the Magnuson-Moss Warranty-Federal Trade Commission Improvement Act.

Intellectual property

Certain trademarks, trade names, service marks, and logos (the “**Marks**”) used in this Manual are registered and unregistered trademarks, trade names, and service marks of MakerBot and its affiliates. Nothing contained in this Manual grants or should be construed as granting, by implication, estoppel, or otherwise, any license or right to use any Marks without the written permission of MakerBot. Any unauthorized use of any information, materials, or Marks may violate copyright laws, trademark laws, laws of privacy and publicity, and/or other laws and regulations. Other company and/or product names mentioned herein may be trademarks of their respective companies.

© 2024 MakerBot Industries, LLC. All rights reserved.

EN - Version 1.1 - Original Instructions

Table of contents

This manual includes the following chapters and topics:

Chapter 1	Safety and Compliance	4
	Compliance and regulatory information	4
	Safety certification	5
	Safety messages	6
	Hazards	7

Chapter 2	Introduction	9
	About the MakerBot Sketch Sprint	9
	Specifications	10
	Main components	11

Chapter 3	Getting started	12
	Unboxing	12
	Setting up the Sketch Sprint	13
	Guided setup	14

Chapter 4	Operation	16
	Touchscreen user interface	16
	Print	17
	Materials	19
	Settings	20

Chapter 5	UltiMaker Digital Factory	22
	Getting started with Digital Factory	22
	Preparing a print	22
	Printing with Digital Factory	22

Chapter 6	Printer maintenance	23
	Firmware	23
	Replacing the extruder	24
	Filament detection	25
	Air filters	25
	Leveling	26
	Build plate maintenance	26
	Lubricating the guide rods	26

Chapter 7	References	27
	Glossary	27
	Contact	28

Chapter 1 - Safety and Compliance

The MakerBot Sketch Sprint was designed with safety in mind. With its fully enclosed design, integrated HEPA filtration system, and compliance with industry safety guidelines, the Sketch Sprint is suitable for classrooms.

Compliance and regulatory information

EU and UK

EC declaration of conformity

The Sketch Sprint is compliant towards the essential requirements and other relevant provisions of:

- Machinery Directive 2006/42/EC,
- EMC Directive 2014/30/EU,
- RED 2014/53/EU,
- RoHS Directive 2011/65/EU,
- WEEE Directive 2012/19/EU.

USA

FCC Supplier's Declaration of Conformity

This equipment has been tested and found to comply with the limits for a Class B digital device, pursuant to part 15 of the FCC Rules. These limits are designed to provide reasonable protection against harmful interference in a residential installation. This equipment generates, uses and can radiate radio frequency energy and, if not installed and used in accordance with the instructions, may cause harmful interference to radio communications. However, there is no guarantee that interference will not occur in a particular installation. If this equipment does cause harmful interference to radio or television reception, which can be determined by turning the equipment off and on, the user is encouraged to try to correct the interference by one or more of the following measures:

- Reorient or relocate the equipment or receiver.
- Increase the separation between the equipment and receiver.
- Connect the equipment into an outlet on a circuit different from that to which the receiver is connected.

FCC Caution

This device complies with Part 15 of the FCC Rules. Operation is subject to the following two conditions: (1) This device may not cause harmful interference, and (2) this device must accept any interference received, including interference that may cause undesired operation. Any changes or modifications not expressly approved by the party responsible for compliance could void the user's authority to operate this equipment.

FCC RF Exposure Warning

This product complies with the FCC radiation exposure limits set forth for an uncontrolled environment with a minimum 8 inches spacing requirement between transmitter and all person's body during wireless modes of operation.

Canada

Industry Canada Compliance Statement

This Class A digital apparatus complies with Canadian ICES-003. This device contains license-exempt transmitter(s)/receiver(s) that comply with Innovation, Science and Economic Development Canada's license-exempt RSS(s). Operation is subject to the following two conditions:

1. This device may not cause interference
2. This device must accept any interference, including interference that may cause undesired operation of the device

Cet appareil contient des émetteurs / récepteurs exempts de licence qui sont conformes au (x) RSS (s) exemptés de licence d'Innovation, Sciences et Développement économique Canada. L'opération est soumise aux deux conditions suivantes:

Cet appareil ne doit pas causer d'interférences

Cet appareil doit accepter toute interférence, y compris les interférences pouvant provoquer un fonctionnement indésirable de l'appareil

Caution

The device for operation in the band 5150–5250 MHz is only for indoor use to reduce the potential for harmful interference to co-channel mobile satellite systems.

Avertissement

Les dispositifs fonctionnant dans la bande de 5150 à 5250MHz sont réservés uniquement pour une utilisation à l'intérieur afin de réduire les risques de brouillage préjudiciable aux systèmes de satellites mobiles utilisant les mêmes canaux;

Radiation Exposure Statement:

This equipment complies with Canada radiation exposure limits set forth for an uncontrolled environment. This equipment should be installed and operated with minimum distance 22cm between the radiator & your body.

Déclaration d'exposition aux radiations:

Cet équipement est conforme Canada limites d'exposition aux radiations dans un environnement non contrôlé. Cet équipement doit être installé et utilisé à distance minimum de 22cm entre le radiateur et votre corps.

Mexico

IFT (México): La operación de este equipo está sujeta a las siguientes dos condiciones: (1) es posible que este equipo o dispositivo no cause interferencia perjudicial y (2) este equipo o dispositivo debe aceptar cualquier interferencia, incluyendo la que pueda causar su operación no deseada.

Safety certification

This product complies with IEC62368-1 with CB Certification for the following countries:

USA/Canada	CSA/UL 62368-1:2019 (cULus)
EU	EN IEC 62368-1:2020+A11:2020
UK	BS EN IEC 62368- 1:2020+A11:2020
Australia	AS/NZS 62368.1:2022
Saudi Arabia	SASO-IEC 62368-1:2020
China	GB 4943.1-2022
Japan	J62368-1(2023)
Korea	KC 62368-1(2021-08)

Safety messages

Your safety and the safety of others are very important. Always read and obey all safety messages.

This guide contains safety and warning notices:



Warning (ISO 7010-W001)

This symbol is used for 'warning' and 'caution' messages:

Warning: You can be seriously injured if you don't follow the instructions.

Caution: You can be exposed to a potentially hazardous serious which, if not avoided, may result in minor or moderate injury.

The following ISO symbols are used to alert you to potential specific hazards:



Magnetic field (ISO 7010-W006)



Electricity hazard (ISO 7010-W012)



Hot surface (ISO 7010-W017)



Crushing of hands (ISO 7010-W024)



Pinching and entanglement hazard



Read the original instructions (ISO 7010-M002). Before using this product, read the complete User Manual to learn about all product features and safety related information.

General safety information

- MakerBot products are not intended for use by persons with reduced physical and/or mental capabilities, or persons with lack of experience and knowledge, unless they are supervised or have been given instructions concerning the use of the appliance by a person responsible for their safety.
- While using this product, children under 12 should be supervised by an adult responsible for their safety. Maintenance actions shall only be performed by an adult, following the provided instructions.
- Do not change the filters while the printer is in operation.
- Dust generation and accumulation should be minimized. Some dust and dry powders can build static electricity charges when subjected to friction and create an ignition hazard.
- If the door must be opened to remove the print, change the printer configuration, or for maintenance or repair actions, close the door immediately afterward to prevent the risk of bumping into it.

Hazards

Electrical safety



The MakerBot Sketch Sprint is powered by mains voltage, which is hazardous when touched. The power supply is located at the back of the printer and is not user-serviceable. Only skilled and instructed persons should remove the back panel. Always check local regulations.



Warning: There is a risk of shock. The electronics of the MakerBot Sketch Sprint are not user-serviceable.



A mains socket with protective earth/ground terminal must be used. Make sure that the building installation has dedicated means of over-current and short-circuit protection. Use a circuit breaker with a current rating not exceeding 16A (for 220-240 VAC circuits) or 20A (for 100-120 VAC circuits).



Caution: The socket outlet must be located near the printer and must be easily accessible. In case of emergency, immediately disconnect the MakerBot Sketch Sprint from the power outlet.



Caution: Plug directly into a socket outlet. If an extension cord is required, only use a properly rated cord with a minimum rating of 10A (for 220-240 VAC circuits) or 15A (for 100-120 VAC circuits).



Only use the original power cable supplied with the device. Do not damage, cut, or repair the cable. A damaged cable should be immediately replaced with a new one.



Always unplug the product before performing maintenance or modifications, unless explicitly stated otherwise for certain (maintenance) processes.

Mechanical safety



Warning: The MakerBot Sketch Sprint includes moving parts that may cause injury. Never reach inside the MakerBot Sketch Sprint while it is in operation. Keep the door and lid closed during operation.



Pinching and entanglement hazard. Do not reach into the top area of the printer during operation due to a pinching hazard. Do not lean over the printer during operation due to risk of entanglement of hair, jewelry, and/or scarfs. This may cause minor pain, but no significant injury to the user is expected from pinching or entanglement by the drive belts.



Crushing or pinching hazard. The force of the build plate is limited but may cause minor injury, so stay out of the reach of the build plate during operation.

Risk of burns



Hot surface hazard. There is a potential risk of burns: the MakerBot Sketch Sprint extruder can reach temperatures above 200 °C, while the heated build plate can reach temperatures above 100 °C. Do not touch either of these parts with your bare hands. This symbol is placed on the print head and on the build plate to warn the user about this risk.



Allow the MakerBot 3D printers to cool down sufficiently before reaching inside, or performing maintenance or modifications, unless explicitly stated otherwise for certain processes. Always wait until the display indicates that the extruder and build plate have cooled down to a safe temperature (below 50 °C). High temperatures are shown on the display with a red thermometer icon.

Emission hazard



Caution: The MakerBot Sketch Sprint melts plastic during printing. Plastic odors and particles may be emitted during this operation. Make sure to set up the MakerBot Sketch Sprint in a well-ventilated area.

During 3D printing, Ultrafine Particles (UFPs), Volatile Organic Compounds (VOCs), and other chemical substances may be emitted. Above certain concentrations (Threshold Limit Values, TLV), these emissions can pose a risk. Concentrations are influenced by the filament and adhesive used, print conditions (e.g. print temperature), room volume, Air Exchange Rate (AER), and number of printers in a room. MakerBot products are designed for use with MakerBot materials and are open for use with materials from third-party suppliers.

Safe use information for MakerBot materials

MakerBot materials can be printed safely without any additional filtering using the recommended temperatures and settings in a wellventilated area (minimum refresh rate or AER of 1.8 for a room size of 30.6 m³). When multiple MakerBot 3D printers are operated in a contained environment, concentrations of UFPs and/ or voes will increase. Depending on the specific situation, please consider other safety measures, such as a separate filter, cabinet, and/or dedicated ventilation system.

Safe use information for third-party materials

Make sure to check with your material supplier whether additional risks and safety measures apply. Additional safety measures may be required for the safe usage of such materials. Always take the relevant information provided by the supplier of third-party materials into account for safe operation. Please check the safety data sheet of each specific material for information. MakerBot cannot be held responsible for any adverse effects from the use and/or performance of third-party materials.

Magnetic field



Static magnetic field hazard. Due to the static magnetic field caused by the magnets in the printer, keep a distance of at least 4 cm (1.5 in) between any implanted electronic medical devices and implants containing ferromagnetic materials.

Personal protective equipment

The following items are recommended for working safely with MakerBot products, especially for performing maintenance actions:

Brush

This is required for safely removing material residue from the tip of the nozzle.

Thermal gloves

It is recommended to wear thermal gloves while cleaning the nozzle as the nozzle will be hot during these procedures.

Chapter 2 - Introduction

Welcome to your new MakerBot Sketch Sprint! In this section of the User Manual, you will be introduced to the parts and specifications of this 3D printer. Getting to know the main components and their names is helpful during the installation and operation of the MakerBot Sketch Sprint.

About the MakerBot Sketch Sprint

MakerBot, a sub-brand of UltiMaker, is the only 3D printing brand dedicated solely to education. For over 10 years, MakerBot has worked closely with educators to transform their classroom and STEM curriculum with 3D printing education.

How the MakerBot Sketch Sprint works.

The MakerBot Sketch Sprint makes three-dimensional objects out of different types of melted materials.

First, download a model from the internet or design a part, then use UltiMaker Digital Factory to translate (or “slice”) your 3D design files into a .makerbot file, which creates instructions for the MakerBot printer. Then, transfer the .makerbot file to the MakerBot printer via Digital Factory or USB drive. The MakerBot Sketch Sprint will melt materials and extrude it out onto the build plate in thin lines to build your object layer by layer. This 3D printing technology is called fused deposition modeling (FDM).

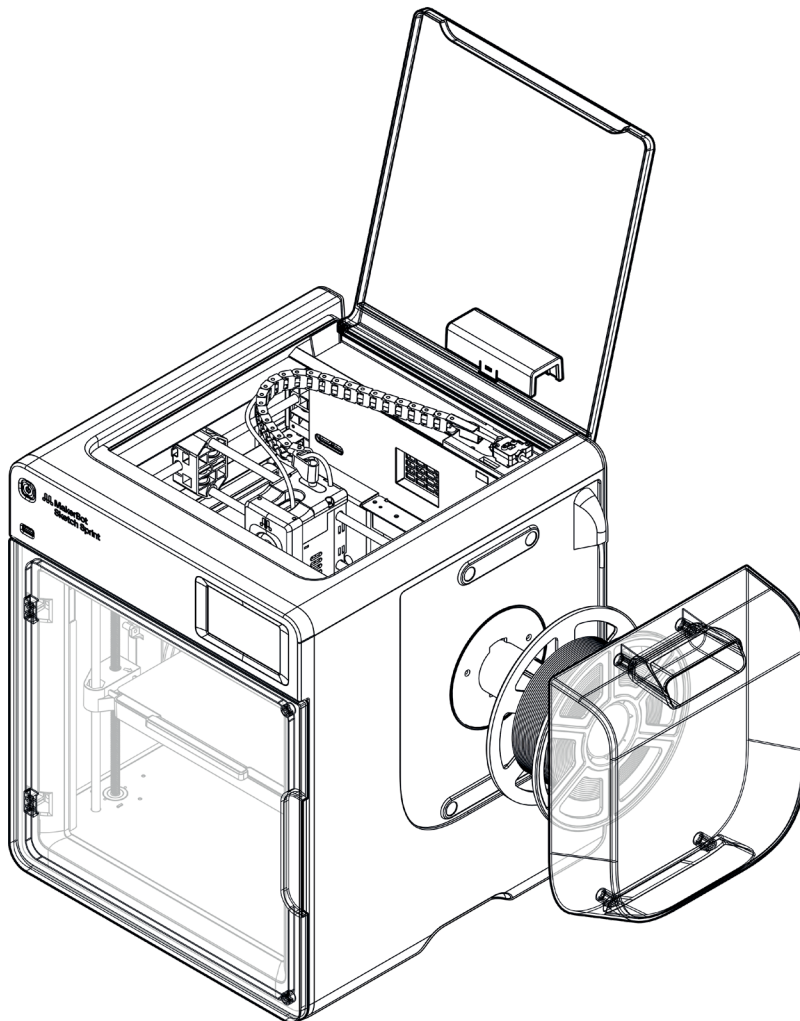

Specifications

Printing properties	
Technology	Fused deposition modeling (FDM)
Build speed	Up to 600 mm/sec
Layer resolution	Maximum capability: 100 - 400 microns Print mode tuned for: 200 microns to provide an optimal balance of high surface quality and quick print time
Maximum build volume	220 mm x 220 mm x 220 mm (8.66 in x 8.66 in x 8.66 in)
Filament diameter	1.75 mm (0.069 in)
Supported materials	MakerBot Sketch Series PLA and Tough PLA
Build plate temperature	110 °C (230 °F) max
Recommended print mode	Fast
Hardware properties	
Extruders	1 (user replaceable)
Nozzle diameter	0.4 mm
Nozzle material	Stainless Steel (SU303)
Sensors	Filament Detection, Mesh Bed Leveling
Build plate	Heated with removable, flexible build surface (PEI)
Filtration system	HEPA and Carbon filter
Display	109 mm color touchscreen (4.3 in)
Camera resolution	1080p
Power requirements	100-250 VAC 350 W / 320W ~50-60 HZ
Connectivity	USB drive, Ethernet, Wi-Fi 2.4GHz and 5GHz
Ambient conditions	
Operating volume	50 dB
Operating temperature	15 °C to 30 °C (59 °F to 86 °F) 10% to 70% RH non-condensing
Storage temperature	0 °C to 55 °C (32 °F to 131 °F)
Physical dimensions	
Dimensions	452 mm x 400 mm x 466 mm (17.79 in x 15.75 in x 18.35 in)
Weight	16kg (35.27lb)
Shipping dimensions	525 mm x 500 mm x 567 mm (20.67 in x 19.68 in x 22.32 in)
Shipping weight	22.26 kg (49.08 lb)
Spools and materials	
Material diameter	1.75 mm (0.069 in)
Spool type	MakerBot Sketch materials
Spool size	Weight: 1 kg (2.2 lb), Diameter: 203 mm (8 in)
System	Open Filament System
Software	
Print job preparation	Cloud: UltiMaker Digital Factory Desktop: Cura 5.9 or newer
Supported model file types	MakerBot (.makerbot), STL (.stl), .catpart, .dae, .gib, .iges, .ipt, .obj, .par, .sab, .sat, .sldprt, .wrl x_t, .3mf
Recommended browser	Latest version of Chrome, Edge, Firefox, or Safari
Safety and compliance	
Directives	LVD, WEEE, RoHS, Packaging, RED, EMC
Safety standards	IEC/ EN/UL 62368-1

MakerBot Sketch Sprint diagram

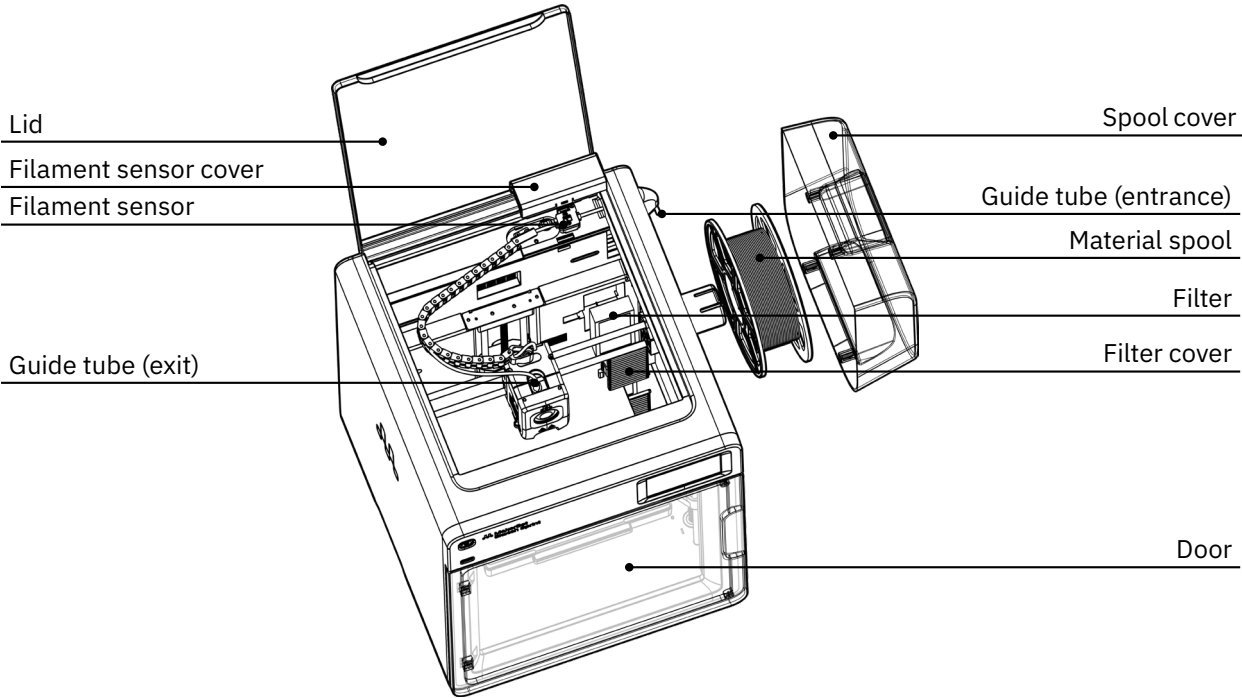
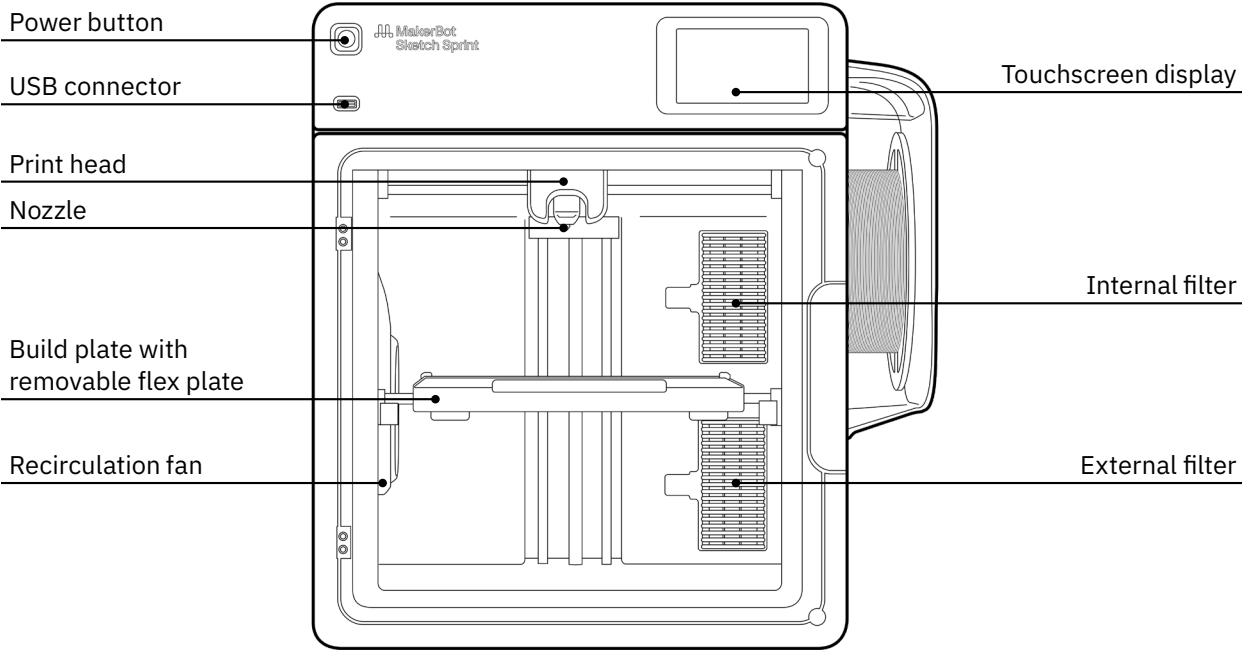

Chapter 3 - Getting Started

When you set up your MakerBot Sketch Sprint 3D Printer, remember that it was built and packaged very carefully. We hope you will take your time and be just as careful unpacking it and getting it set up.

Unboxing

A Quick Start Guide with unboxing instructions was included with the MakerBot Sketch Sprint. Follow these instructions to properly unbox your new 3D printer.

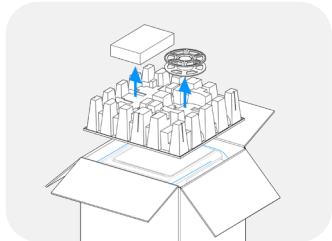

1. Open the box and remove the accessory box, filament spool, and top packaging material.

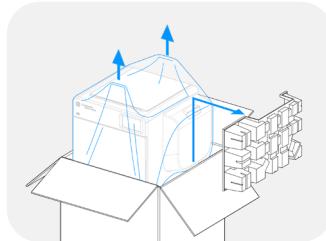

2. Use the plastic handle to lift the printer in the plastic bag out of the box.

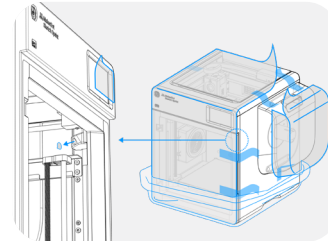

3. Take the printer out of the bag and remove the protective films on the outer panels and on the camera lens inside the build chamber.

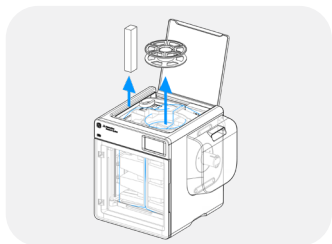

4. Open the top lid and remove the second filament spool and power cords.

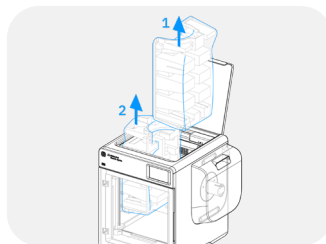

5. Remove the right (1) and then left (2) inner packing materials.

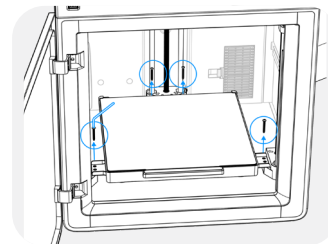

6. Use the 2mm hex key provided to remove 4 screws holding down the Z-stage.

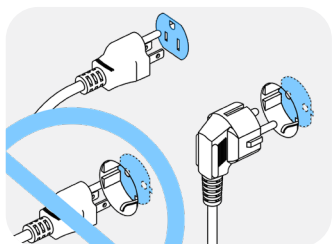

7. Locate the power input on the rear of the machine and use the correct cable to connect the machine to an accessible power outlet.

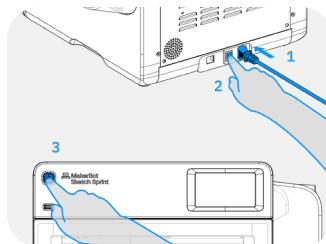

8. Enable power to the machine by using the switch next to the power inlet, then press the power button on the front left of the machine to turn it on.

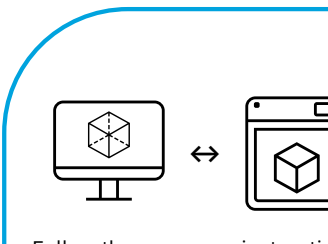

Follow the on-screen instructions to finish setting up the printer.

Visit digitalfactory.ultimaker.com to create an account and connect your printer to UltiMaker Digital Factory.

UltiMaker Digital Factory is a browser-based app that enables you to prepare and send files directly to your printer.

Setting up the Sketch Sprint

Note: In case of conflicting information between this Manual and the on-screen instructions, follow the on-screen information, since it is updated more frequently. Always ensure your printer is running the latest firmware version (see **Chapter 6 - Maintenance**).

Turning on your MakerBot Sketch Sprint

The power-enable switch on the MakerBot Sketch Sprint is located next to the power inlet at the bottom rear side of the printer. Once the printer is connected to a power outlet using the provided cable, toggle this switch to enable power to the machine.

Press the power button on the front left of the machine to turn the printer on.

To turn off your MakerBot Sketch Sprint, press the power button on the front of the printer and follow the print on the UI touchscreen. You can also hold the power button for 10 seconds to force the printer to shut down.

Turn the power-enable switch to the off position before unplugging the power cord.

The Guided Setup

When booting up your machine the first time, you will be guided through the initial onboarding setup process using the MakerBot Sketch Sprint user interface.

See the next section for more information and the steps included in the Guided Setup.

Preparing your model to print

The 3D model must be formatted, or “sliced” for the MakerBot Sketch Sprint using UltiMaker Digital Factory’s cloud slicer or the Cura desktop application. UltiMaker Digital Factory and Cura can import an STL or other supported 3D file type and export a MakerBot (.makerbot) file type.

Go to digitalfactory.ultimaker.com to get started with your Digital Factory workspace, or go ultimaker.com/cura to download the latest version of the UltiMaker Cura desktop application.

Please see **Chapter 5 - UltiMaker Digital Factory** for more information about print preparation.

Supported file types

MakerBot (.makerbot)

.stl, .catpart, .dae, .gib, .iges, .ipt, .obj, .par, .sab, .sat, .sldprt, .wrl, .x_t, .3mf

Guided Setup

The first time you turn on your MakerBot Sketch Sprint, you will be guided through the initial setup process using the MakerBot Sketch Sprint user interface. This guided setup will walk you through setting a name for your printer, connecting the printer to an internet connection, setting up a security PIN, running calibrations, loading material, running your test print, and connecting your printer to Digital Factory .

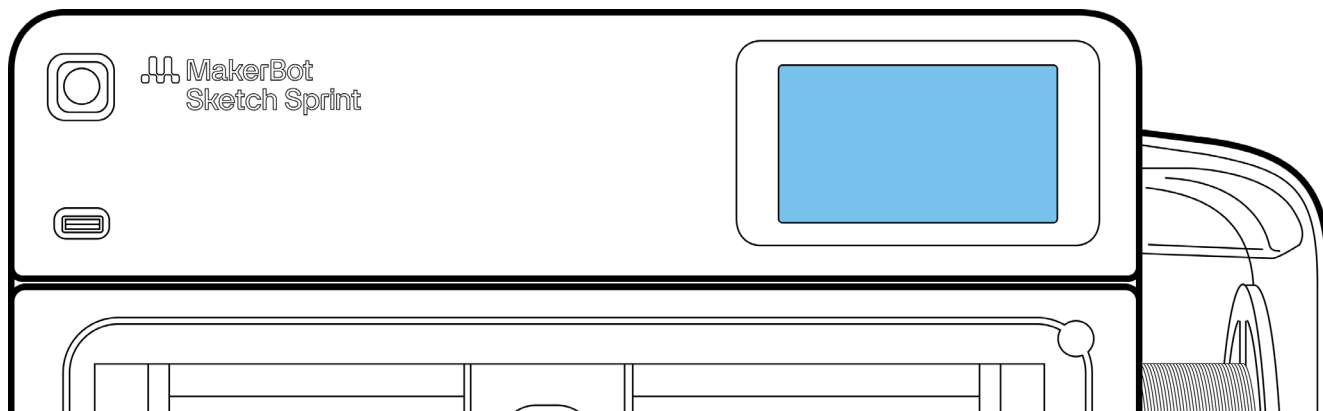

The touchscreen located at the upper right of the machine operates the MakerBot Sketch Sprint. After you turn on the printer for the first time, you are first asked to select your preferred language. You will then be taken through the guided setup, consisting of the following steps:

Naming your printer

You can choose a custom name for your MakerBot Sketch Sprint 3D printer. If you have multiple printers available, this is a very useful feature to tell them apart, especially when they are connected to the UltiMaker Digital Factory. Enter a custom name using the on-screen keyboard.

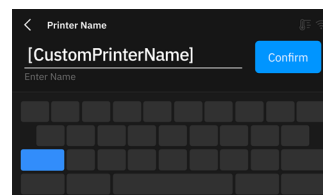

Network connection

The MakerBot Sketch Sprint can connect to a network via Wi-Fi or Ethernet. With an active network connection, you can set up the printer in your Digital Factory workspace. See **Chapter 4** for more information about networks and **Chapter 5** for more information about the UltiMaker Digital Factory.

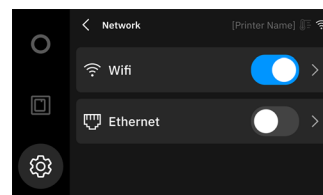

Setting a security PIN

The MakerBot Sketch Sprint includes a Security PIN feature which allows you to lock the printer interface to prevent unwanted or unsupervised activity. Choose a 4-digit PIN that will be used to unlock the printer when PIN mode is enabled. Learn more about this feature in **Chapter 3**.

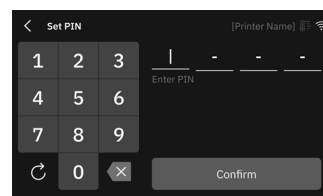

Calibration processes

The MakerBot Sketch Sprint has three automatic calibration processes that help maintain the best performance for optimal print quality. These calibrations include Leveling, Vibration Test, and Nozzle Temp Calibration. Run all three during the guided setup.

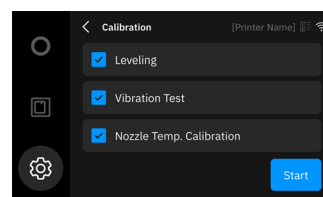

Loading the material

Before you can start a print, the filament must be loaded into the extruder. Follow the instructions on the touchscreen.

Place the spool on the spool holder and push the end of the filament through the guide tube toward the print head. Feed the filament into the print head until the extruder grips it. You can now reattach the guide tube. When the material is extruding from the nozzle, complete the process.



Warning: Hot surface! The nozzle will become hot during this process. Do not touch the nozzle and be careful when removing the extruded filament from the printer.

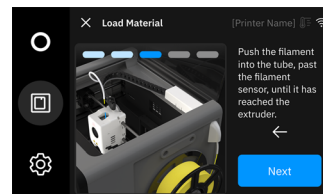
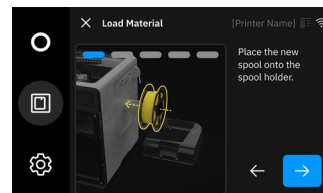

Test print

Once you have loaded material into the extruder, it is time to run a test print to ensure your MakerBot Sketch Sprint is set up successfully. Tap **Start Test Print** to begin; the build plate and extruder will heat up. It is recommended that you watch at least the first few layers to ensure the print is adhering to the build plate. The test print will take around 11 minutes. The display screen will show progress of the print.

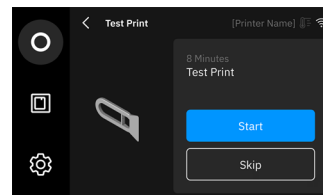

Connecting to Digital Factory

Connect your MakerBot Sketch Sprint to the UltiMaker Digital Factory for a seamless, cloud-based workflow.

Go to digitalfactory.ultimaker.com and log in (or create a new account). In the Printers tab, select Add Printer to set up a new machine. Choose MakerBot Sketch Sketch Sprint. The screen will ask for an authorization code. The printer will display a six-digit code on the touchscreen. Enter this in the Digital Factory to complete the printer connection.

Note: Your MakerBot Sketch Sprint must have an active internet connection.

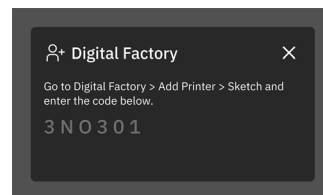
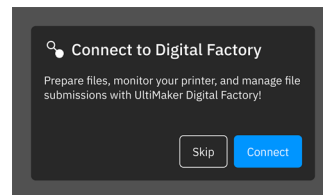

Rerun the guided setup

The guided setup is now completed! In case you want to go through the guided setup again, select **Settings > Utilities > Reset To Factory**. Resetting to factory settings will erase any modified printer settings and also remove any Digital Factory connections. Reboot the printer after the reset to rerun the guided setup.

Chapter 4 - Operation

Your MakerBot Sketch Sprint is now fully set up and ready to print! In this chapter, you'll learn how to navigate the printer's user interface, start and remove prints with ease, and change materials. We'll cover all handy features and options in the menu to help you make the most of your Sketch Sprint.

Touchscreen User Interface

The touchscreen interface gives you options for managing your printer and the printing process. Navigate through the menu to start and tune prints, or change settings for the printer.

Home screen

The touchscreen gives you three options for managing your printer and the printing process:

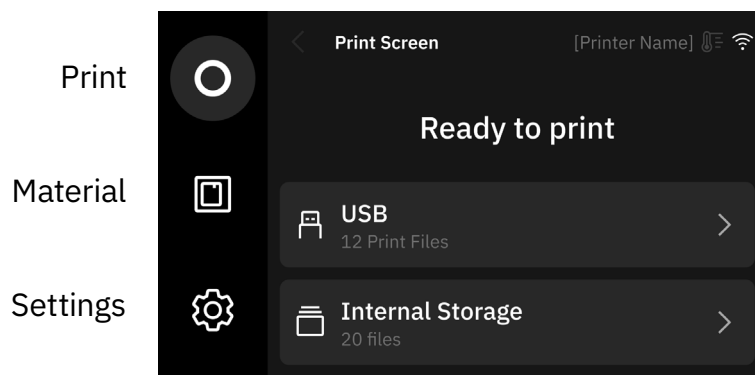

The **Print** menu (circle icon), is the default screen. From here, you can start print files from a USB drive or from the printer's internal memory. During a print, you can see the progress indicator and perform actions such as pause, abort, or tune the print.

In the **Material** menu (printer icon) you can see the printer's configuration. It shows which material is currently loaded and this menu provides instructions on how to unload and load material spools. From this menu, you can also manually set the temperatures for the extruder and build plate.

The **Settings** menu contains many additional features for the MakerBot Sketch Sprint. These options are divided into three sub-menus: **Printer** (maintenance actions and feature toggles), **Network** (change network options and connect to the Digital Factory), and **About/System** (security settings and firmware updates).

See the following sections for more information about all menu options.

UI features

The Sketch Sprint firmware contains colors and images to make all workflows as clear as possible:

- Green checkmarks indicate that a process was completed successfully.
- Yellow exclamation marks call your attention to an important notice.
- Red crosses warn that this cancels a process or that a procedure has failed.
- The action buttons are highlighted in blue to show the next step or ask to confirm. The button will be grayed out if you are not ready to proceed.
- Progress bars show how much time is left for a certain process.
- The thermometer icon in the top right corner turns red if the extruder or build plate is above 50 °C.
- Images with highlights clearly show what actions must be taken for some steps.

Print

Easily start and monitor print jobs from the MakerBot Sketch Sprint user interface. This section shows the offline workflow; starting a print from USB or the internal storage. You can also send print jobs to the printer via the Cloud, if the Sketch Sprint is connected to the Digital Factory. See more information in **Chapter 5**.

1. Start a print job

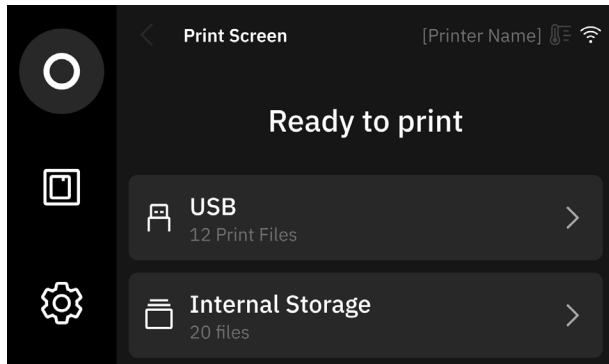

From the main screen, start a print file from your installed USB drive or saved on the printer's internal memory. Browse through the list or folders and select the file you want to print.

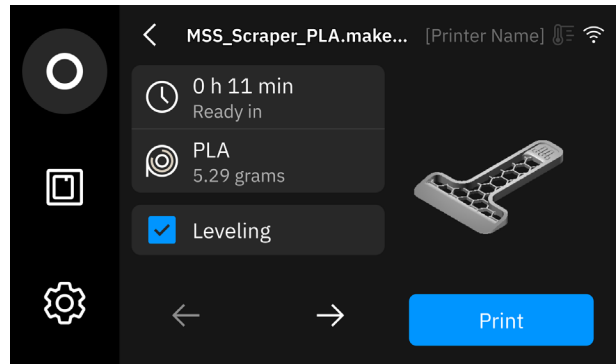

The next screen shows some information about the print job, such as the time and material required, and some of the main settings. Press the **Print** button to begin.

2. Print progress

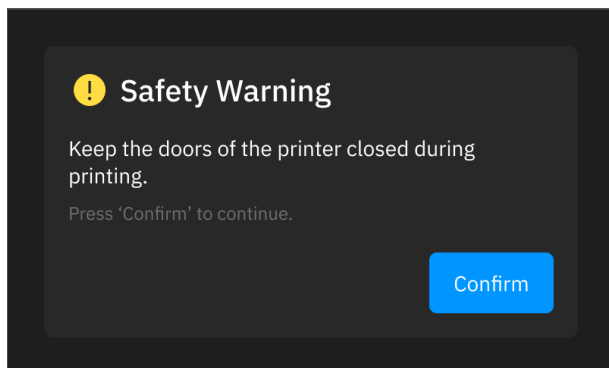

Before the print starts, a safety warning notifies you that the door and top lid should be kept closed during printing. The file will copy on to the printer and begin printing.

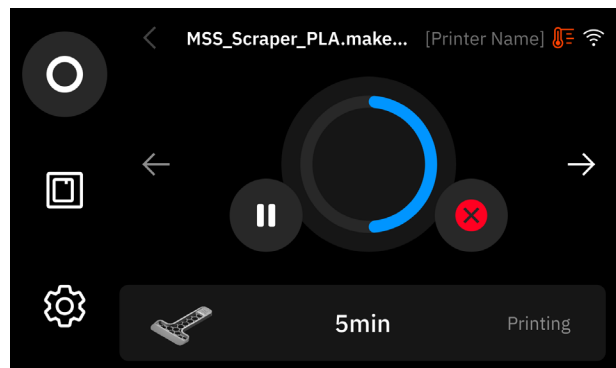

While printing, the progress will be shown on the screen. You can pause the print, change material, and access more info while a print is in progress. In case of problems, press the red **X** to abort the print.

3. Print complete

When the print is finished, the user interface will prompt you to remove the printed part from the printer. Always wait until all components have cooled down.

Remove the print, place back the build plate, and select **Confirm Removal**. This will allow the next print job to start.

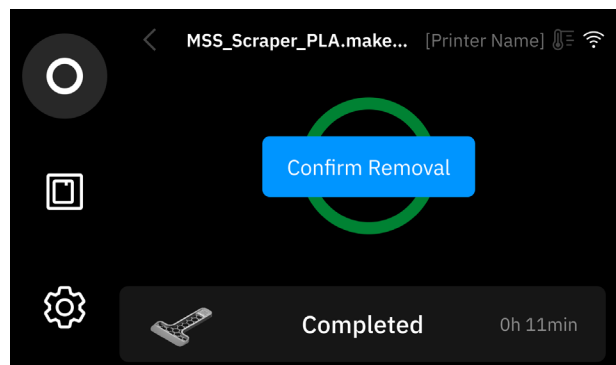

Pause or abort a print

If necessary, you can pause the print or abort it completely. You can do this from the print progress screen.

On the left of the print progress circle is a pause button. Press it to pause the print. This may take a few seconds. The printer will then stop the print process and the print head will move away from the printed part.

Note that components remain hot; be careful when reaching inside the printer. When you're ready, press the play icon to resume the print.

To abort a print that is in progress, press the red button with an **X** at the right side of the print progress circle. A popup screen will follow to make sure you intended to stop the print. After aborting, you cannot continue the print.

After a few seconds, the printer will stop and the build plate will move down. Wait until all components have cooled down and remove the print from the build plate.

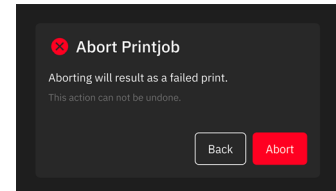
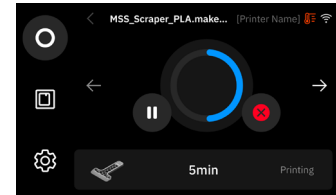

Removing a print from the build plate

When the print is finished (or aborted) and after it has cooled down, you can take the build plate with the print on it from the printer. To do so, hold the handle of the build plate at the front of the build platform and lift it up. Then pull the build plate and print towards you, to remove it from the printer.

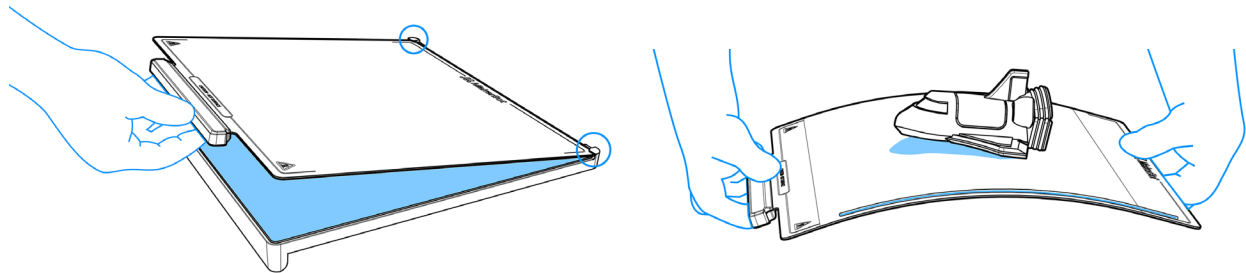

Detach the print from the build plate by slightly flexing the plate. Take proper measures to prevent the print from falling. If the print does not completely pop off the build plate's smooth surface, use your hands or a tool to gently separate the print from the plate. Make sure to also remove the purge line on the right side of the plate.

Some pieces of the print may remain on the plate or be more difficult to remove. Your printer comes with a scraper test print installed that can be used to help remove prints. Alternatively, you can use a flat, non-sharp tool such as a putty knife to remove the remaining pieces.

Note: Never use a sharp knife to remove printed material from the build plate; doing so can damage its surface.

When the build plate is cleared, place it back on the build platform. Start with positioning the rear corners of the build plate. Then lower the front of the build plate while it is being pulled in down by the magnets.



Warning: Hot surfaces! Parts of the printer might be hot. Leave the printer closed until the thermometer icon at the top right corner of the screen is not colored red anymore.

After you select **Confirm Removal** on the touchscreen, the next print job can be started.

Material

The MakerBot Sketch Sprint is compatible with Sketch series materials. This includes PLA and Tough PLA (1.75 mm). The spool is placed on the integrated spool holder on the right side of the printer. A clear cover is placed over the spool. This protects it from dust and external influences, such as someone accidentally touching the material during the print progress.

The extruder is located in the print head, this means loading a new spool or removing the material is a manual process. The printer will guide you through the steps. You will need the wire cutters from the Sketch Sprint accessory kit.

Select the **Material** menu to load or unload material. Follow the instructions on the display.

Load material

To place a new spool of filament, first ensure that the cover is removed and disconnect the guide tube from the print head.

1. Place the spool on the spool holder on the right, with the filament in a counter-clockwise direction.
2. Use the wire cutters to cut the end of your material to create a clean edge.
3. Insert the filament into the guide tube and push it until it reaches the extruder.
4. Wait for preheating to complete; this may take a few minutes. The screen will show the progress.
5. Guide the material into the extruder until you feel it getting pulled in.
6. Reattach the guide tube and wait for material to extrude from the nozzle.
7. You can now select the material type and place the cover back to complete the process.

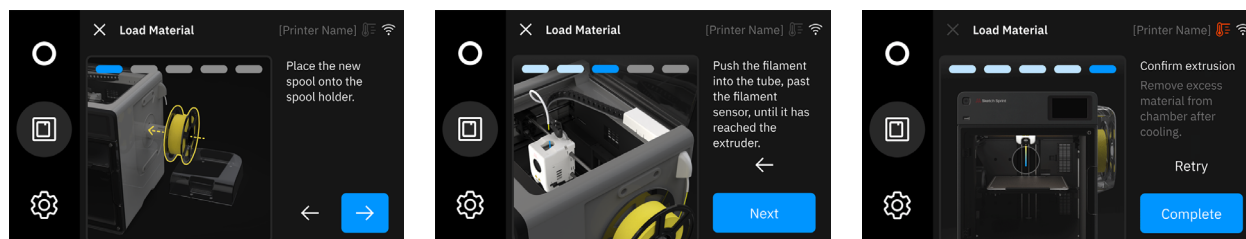

Loading tips:

- **Cut off bent portions:** Before loading a new spool, remove a few centimeters / inches from the spool (including any bent portions) before inserting it into the guide tube. Any materials that may be bent or crimped may get stuck or break along the way to the extruder.
- **Used spools:** When loading a previously used spool, remove any deformed material at the leading end of the filament.
- **Brittle materials:** If the material feels brittle or breaks easily, do not load this into the printer. Remove at least 60 cm / 2 feet of the material. To determine if your material is brittle, try to bend it a few times. If you can bend it at least three times before breaking, you can continue loading.
- **Color / material change:** When you are switching to a different color or material type, let it extrude for a while at the end of the loading process. Wait until the extruded material shows the color of the new spool.

Unload material

You can remove a spool from the printer if you want to switch to a different color or material type, if the filament runs out during printing, for repair or maintenance reasons, or if the printer will not be used for a while.

Note: The end of filament flow during printing is slightly different from removing a (partially) full spool. Follow the instructions on the display.

Disconnect the guide tube from the print head. Use the wire cutters to cut the material slightly above the print head.

When manually unloading a spool:

Remove the spool cover and rewind the spool to pull the filament out of the guide tube. If you want to switch to a different spool, follow the instructions under **Load material**.

In an End-of-filament situation during a print:

Pull the material out of the guide tube at the print head side. The procedure will automatically continue with loading a new material spool so you can continue printing.

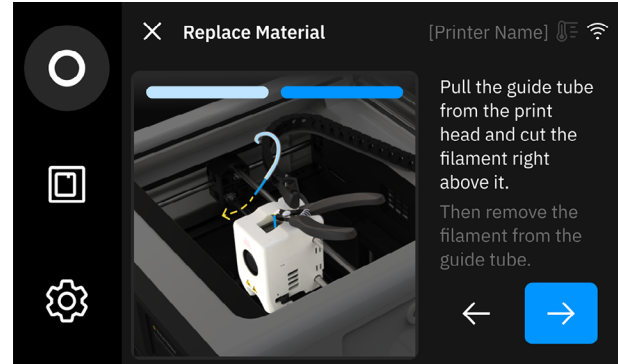

Unloading tips:

- **Keep the material tight:** As you are rewinding the spool, ensure to keep the material tightly wound. Hold the end of the filament as it comes out of the guide tube, otherwise, it could unravel or tangle on the spool.
- **Secure the end of the filament:** After unloading the filament, insert the end into one of the storage slots on the spool. This prevents the filament from getting tangled and makes it much easier when you want to reload the spool again later.
- **Material storage:** Store any unused spools in a cool dry place. For the best results, place any opened spools in a resealable bag with some desiccant.

Settings

The **Settings** menu contains a wide variety of options and features that help you make the most out of your 3D printer. This section explains all of the menu options.

Tip: Visit the MakerBot Sketch Sprint support pages at support.makerbot.com for more information about each of the settings.

Printer

Adjust Position: Manually move the extruder (X/Y) or build platform (Z) by selecting the appropriate icon and distance and then using the arrows. Press the home icon to home the system before manual position adjustments (required).

Maintenance: There are three calibration processes that help ensure the best performance of the printer.

- **Leveling** helps ensure good first layer performance.
- **Vibration Test** helps ensure good print quality, especially at the high speeds that Sprint operates at.
- **Nozzle Temp Calibration** helps finetune the heating for the particular nozzle that is installed.

All 3 processes should be performed after a factory reset or whenever a new nozzle is installed.

Filtration: Manually turn on the internal or external filtration system to circulate and filter the air inside the printer outside of a print process. You will also find instructions here on how to change the filters when replacement is due.

Camera + Video: Enable the camera to view the printer chamber from Digital Factory or to capture Timelapse Videos. Timelapse videos can be copied to a USB drive by pressing the edit icon and then the copy icon. Timelapse videos can be erased from printer memory by pressing the edit icon and then the trash icon.

Light: Toggle the chamber LEDs on or off.

Sound: Toggle the printer notification sounds on or off.

Change Nozzle: Select this option if you need to remove or install a new nozzle. The printer must be powered off before removing and installing a nozzle. Selecting this option will show a QR code to our support page with guidance on how to remove/install a nozzle. You can find these instructions [here](#).

Filament Detection: Toggle filament detection on or off. The filament detection switch is located at the top right rear corner of the printer, where the filament is routed from the spool to the extruder.

Auto Shut off: Toggle auto shut off on or off. If on, the printer will turn off to conserve power automatically after 30 minutes of inactivity.

Network

Wi-Fi: Enable Wi-Fi to view available networks and establish a Wi-Fi connection. To connect to a new network, you can use the on-screen keyboard to enter the password, if necessary. In this menu, you can also disable Wi-Fi or forget a saved Wi-Fi network connection.

Ethernet: Select this option to view the current Ethernet connection status. The printer must be connected via Ethernet cable. The port is located at the back of the printer.

Static IP: Use this option to configure your network connection with specific IP address, netmask, gateway, and DNS server.

Digital Factory: This will display a 6 digit code that is required to connect the printer to your workspace in the UltiMaker Digital Factory. See **Chapter 5 - UltiMaker Digital Factory** for more information.

About / System

Printer Info: View the following details of your printer: firmware version, serial number, hours of printing, filament usage, IP address, MAC addresses, and remaining available internal memory.

Printer Name: Change the name of your printer. This is very useful when you are working with multiple printers. This name is what will appear in Digital Factory.

Language: Change the language that is displayed on the printer user interface.

Copy Logs to USB: Select this option to copy printer logs to a USB drive inserted in the front USB port. Printer logs may be requested by our support team to help understand and resolve issues.

Update Firmware: If the printer has an active internet connection, selecting this option will check if there is a newer version of firmware available for download from our server.

Security Settings: Set or remove a security PIN. You can also lock the printer from this menu when a PIN is already set.

Factory Reset: Resetting to factory settings will erase any user data and modified settings from the printer. It will also erase any Digital Factory connections.

Chapter 5 - UltiMaker Digital Factory

UltiMaker Digital Factory gives you the tools to streamline your 3D printing workflow from a browser on your computer. From there, you can queue and start 3D prints, monitor 3D prints remotely, organize your 3D print files in a digital library, and manage printers and teams.

Getting started with Digital Factory

1. Go to digitalfactory.ultimaker.com.
2. Log into your UltiMaker Account. If you don't already have a UltiMaker account, click **Sign Up** to create one.
Tip: You can also log in using your MakerBot or Google Accounts.
3. Set up your EDU workspace.

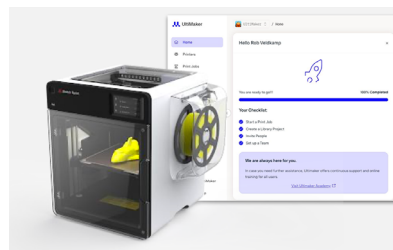

Add your printers

Your printer must have an active internet connection in order to be connected to Digital Factory.

To add printers to your account, navigate to the **Printers** tab and select: **Add Printer > MakerBot > Sketch Sprint** and follow the instructions on the screen. You will need the authorization code from the printer menu.

Preparing a print

To start a 3D print on the MakerBot Sketch Sprint, the 3D model must be sliced first. The printer reads 3D print files in the .makerbot format. UltiMaker Digital Factory can generate .makerbot files from many 3D file formats using a powerful and user-friendly cloud slicer.

Select the **Prepare** tab in UltiMaker Digital Factory and load a 3D file to get started. Ensure that the correct printer and material are selected on the right side.

You can use the adjustment tools on the left of the interface to move, scale, rotate, or multiple your model(s). On the right side of the interface, you find the profile and settings. Make adjustments if necessary, such as adding support structures or changing the infill settings.

When you are ready, click **Slice** to generate the .makerbot file. Use **Preview** to evaluate the result. This allows you to check the sliced print file layer by layer. You will also see information about the print, such as the duration and the amount of material needed.

Printing from Digital Factory

To start the actual print job, select queue and choose one of the connected printers to place the print job in its queue. Alternatively, you can choose to save the .makerbot file to a USB drive or store it in the **Library** of UltiMaker Digital Factory.

During the print, you can monitor the print progress and view the camera. If you want, you can pause the print from the Digital Factory by pressing the **Pause** button for the selected print job. In case of problems with the print, you can also abort the print job by pushing the X icon.

When the print has finished, remove it from the build plate. Don't forget to select **Confirm Removal**; this will make the printer available to start the next print job from the queue!

Chapter 6 - Printer Maintenance

As soon as you take your MakerBot Sketch Sprint 3D printer out of the box, it is ready to print high-quality models. However, like any machine, routine maintenance is needed. Here are some ways you can keep your MakerBot Sketch Sprint printing smoothly.

Firmware

Please ensure you have the latest firmware installed on your machine at all times. If your machine is connected to the internet, it will show a notification when a new firmware version is available for automatic download. If your printer is not connected to the internet, you may download the latest firmware file from ultimaker.com/sprint-firmware and install it via USB.

Having up-to-date firmware an important factor in getting the most out of your MakerBot Sketch Sprint.

Update via network

Connect your printer to the internet by using an Ethernet or Wi-Fi connection. See **Chapters 3 and 4** for more information about setting up a network connection.

Once your MakerBot Sketch Sprint has established an internet connection, it will notify you if a newer firmware version is available for download. Tap **Confirm** in the prompt to update to the latest firmware and the download will begin.

When downloading is completed, a printer restart is required to complete the update process. Follow the on-screen instructions to press and hold the power button for 10 seconds to shut the printer down. Then, press the power button again to restart the printer and finish the update.

Update via USB drive

If the MakerBot Sketch Sprint is not connected to a network, you can update the firmware using a USB drive. Visit ultimaker.com/sprint-firmware to download the latest firmware.

When the download is complete, transfer the file to a USB drive. Please ensure that the firmware file is not embedded inside another folder on your USB drive, or else the printer will not be able to select it. Also ensure that there is only one firmware file on your USB drive.

Insert your USB drive into the USB port below the power button on the front left of the printer. Next, power cycle the printer by pressing the power button, confirming the prompt on the touchscreen to power off, and then pressing the power button once more to reboot the machine.

Once the new firmware has been transferred to the printer, you will be prompted to remove the USB drive and restart the printer once more to complete the firmware update. Follow the on-screen instructions to press and hold the power button for 10 seconds to shut the printer down. Then, press the power button again to restart the printer and finish the update.

Calibrate after updating

When new firmware is installed, it's best to re-run all the calibrations (**Leveling, Vibration Test and Nozzle Temperature Calibration**). These are found under **Settings > Maintenance**.

Replacing the extruder

The extruder, or nozzle assembly, on the MakerBot Sketch Sprint, can easily be replaced. If the nozzle is clogged and the blockage can't be cleared, or if the nozzle is damaged, quickly replace it with a new one. This only takes a few minutes.

Remove the extruder

The extruder can be removed with material still inside; you'll have to cut it as when unloading a material spool. The printer must be powered off before removing or installing an extruder.

Note: The **Settings** menu contains an option for the nozzle replacement (**Printer > Change Nozzle**). This will direct you to a support article with more information and instruct you to turn off the printer.



Warning: Hot surfaces! Wait until the nozzle has cooled down to a safe temperature before proceeding. When the thermometer icon on the display is not red anymore, turn off the printer.

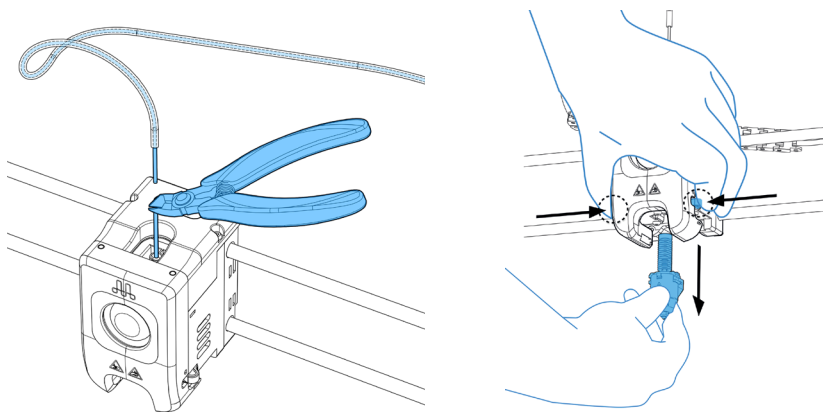

1. Disconnect the guide tube from the print head and cut the filament right above the extruder.
2. There is a small black clip on either side of the print head. Firmly squeeze the two clips.
3. While pressing the clips, grab the nozzle and pull it out of the print head. Keep pulling until the extruder (with the filament) is completely out.

Note: Depending on your printer, this may require a more secure grip on the extruder. You can wear gloves to prevent pinching.

Installing a new extruder

To install a new extruder, first ensure that it is correctly aligned with the print head. The connector should face toward the back of the print head. Make sure that the printer is turned off before removing or installing components.

1. Carefully but firmly slide the extruder upward into the print head until it clicks into place.
2. Check that the clips on each side of the print head have reset. If not, the extruder is not secured properly. You can gently pull at the extruder to check this.
3. Turn on the printer again.
4. On the touchscreen, select **Settings > Printer > Maintenance** and run the three calibration processes (**Leveling**, **Vibration Test** and **Nozzle Temp Calibration**) for the best results after installing a new extruder.
5. You can now reload the material and connect the guide tube to the print head again.

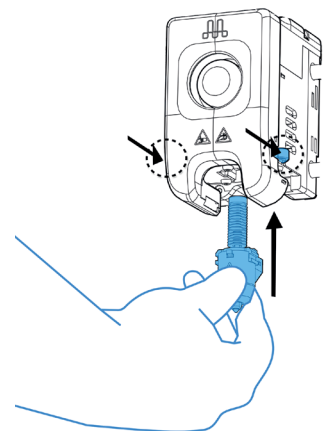

Filament detection

The printer has a filament detection sensor located underneath a white cover at the top back of the printer. The sensor detects when the printer has reached the end of the material spool. If filament detection is enabled, and the spool reaches the end of the filament during a print process, the print will be paused until a new spool is loaded.

It is recommended to ensure the filament detection sensor is enabled. This can prevent failed prints if the material runs out. You can change the settings for this sensor in the Sketch Sprint menu:

Settings > Printer > Filament Detection.

Air filters

To prevent the potential exposure of users to small particles, the Makerbot Sketch Sprint 3D printer can filter the air from the build chamber. The printer will automatically turn on the filtration system when printing. The filtration fans can also be turned on manually, outside of a print process.

Internal and External filtration

Filtration can be manually switched on or off, outside of the print process, in the touchscreen menu: **Settings > Printer > Filtration.** There, you can switch on either external filtration or internal filtration.

External filtration is used when printing materials such as PLA and Tough, that require relatively low build chamber temperatures. In this case the bottom filter is used.

Internal filtration is used when printing materials that require higher temperatures. Internal filtration keeps the heated air in the build chamber. The internal filtration prevents particle levels to build up inside the printer. In this case the top filter is used.

It is recommended to keep the door and lid of the printer closed while printing. The filtration system will be most effective if the build chamber is kept enclosed.

Filter replacement

The air filters are a consumable part and replacement is advised after 500 hours.

The printer keeps a record of the filter usage by counting the hours that filtering has been used during printing. The printer will notify you when 500 hours of printing have elapsed. You can also check if it is time to replace the filters by navigating to **Settings > Printer > Filtration.**

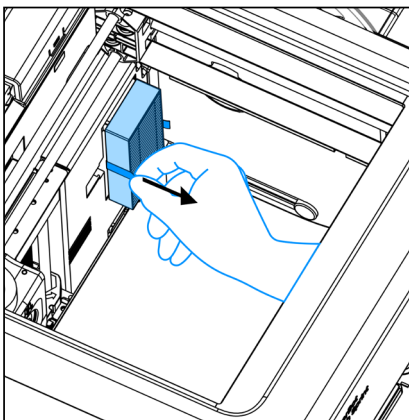
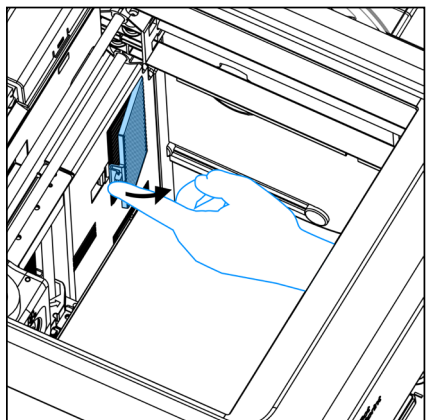

To replace the filters with new ones, select **Filter Usage > Change Filters**. The instructions on the display will guide you to adjust the build plate level and replace the filters. Make sure that you place the filters in the right orientation, with the pleats facing forward and the flat foam surface towards the rear of the printer.

The images below show the two sides of the filter. The foam side is highlighted in blue (left image), and the right side image below shows the front side of the filter, which should face towards you.

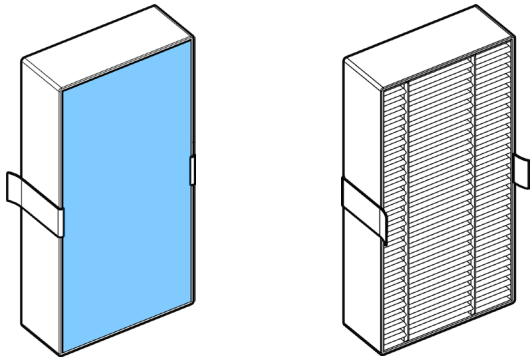

To fit the filter covers back in place, push the two hooks along the right side of the cover with the corresponding holes in the rearwall. Then push it in place at the left side to engage the snap hook. Be careful not to damage the pleats of the filter itself.

Pressing **Finish** at the end of this workflow will reset the 500 hour timer for the filter usage. Make sure to properly discard the used filters.

Leveling

The automatic mesh bed leveling process should be run if you are noticing any print quality issues, especially if related to the first layer, or whenever an extruder is removed and installed.

To run the leveling calibration process on the MakerBot Sketch Sprint, use the touchscreen to navigate to **Settings > Printer > Maintenance** and select **Leveling**.



Maintaining the build plate

The surface of the MakerBot Sketch Sprint build plate allows for excellent print adhesion and print quality. The surface can be cleaned with isopropyl alcohol or dish soap and water to remove oils and residue from handling.

Go to store.ultimaker.com to order more build plates (US and Canada), or contact your local reseller.

Lubricate the guide rods

Please apply grease to the printer guide rods once every month, or 500 hours of regular use, or if the printer has not been used for an extended period of time. Some grease is included in the accessory kit of the MakerBot Sketch Sprint.

Chapter 7 - Reference

Glossary

Build plate: Flexible metal plate on which the 3D print is built. This plate is optimized for a great user experience. It offers good adhesion during printing, but also easily releases the print when finished. Simply remove the plate from the printer and gently bend it. The removable flexible build plate is held onto the build platform with magnets.

Build platform: The complete Z stage assembly on which the flexible build plate is placed. This part of the printer moves up and down (Z direction). The build platform contains a heater and pressure sensors for automatic mesh bed leveling.

Calibrations: A set of three procedures to ensure optimal reliability of the Sketch Sprint. The calibrations include Leveling, Vibration Test, and Nozzle Temp Calibration.

Carriage: The print head assembly. This is mounted onto the guide rods and contains the extruder (nozzle) assembly. It moves in the X and Y directions during printing.

Ethernet cable: The cable used to connect your MakerBot Sketch Sprint to a local area network.

Extruder: This is the nozzle assembly, which is placed in the print head. This part heats up and melts the filament and deposits it during printing. The nozzle has a 0.4 mm diameter. The extruder assembly can easily be replaced.

Filament: The material used for 3D printing. The MakerBot Sketch Sprint is compatible with Sketch Series PLA and Tough (1.75 mm).

Firmware: The software that runs on your MakerBot Sketch Sprint containing the user interface.

Gantry: The part of the printer system containing timing belts and pulleys. The gantry is responsible for moving the carriage (print head) in the X and Y directions.

Guide tube: The plastic tube that guides the MakerBot filament from the material spool to the extruder (also referred to as filament guide tube).

Guided setup: The set of tasks that runs when you turn on the MakerBot Sketch Sprint for the first time. The setup assistant helps you load material and start a test print.

Internal storage: The part of the printer's onboard memory where your saved prints and timelapse videos are stored.

.makerbot: The format of print files for your MakerBot printer. Print files contain the instructions your printer uses to produce a print.

Profile: The settings used to slice your 3D model and create a print file. UltiMaker Cura and the Digital Factory cloud slicer contain preset print profiles.

Slicing: The process of turning a 3D model into a print file containing instructions for your MakerBot Sketch Sprint. The Sketch Sprint uses print files with the extension .makerbot.

Spool: This refers to the spool of 3D printing filament (material). The filament is wound on a spool that can be mounted onto the right side of the printer. A plastic cover protects the spool from dust and accidental interferences.

Touchscreen: The touchscreen at the upper right corner of the MakerBot Sketch Sprint. The touchscreen allows you to start prints, change settings, and view status information.

UltiMaker account: The username and password you will use to sign in to Digital Factory.

UltiMaker Digital Factory: A cloud-based platform for managing your printers, print jobs, and projects. The Digital Factory is compatible with the Sketch Sprint and other MakerBot and UltiMaker 3D printers.

USB drive: You can use a USB drive to transfer print files to and from the MakerBot Sketch Sprint. Make sure that the USB drive is formatted to FAT32. USB drives that are formatted to NTFS will not be recognized.

Contact

Support

support.makerbot.com

Our website has documentation and troubleshooting information about your MakerBot Sketch Sprint. It's a great resource when you want to try to solve issues quickly on your own.

support.makerbot.com/s/contactsupport

At MakerBot, we take pride in offering expert, responsive, friendly customer support to our customers around the world. If you need help resolving an issue with your MakerBot Sketch Sprint, open a case with the MakerBot Support Team at the web address above.

Sales

sales@makerbot.com

To learn about other MakerBot products, including MakerBot material, please email the address above, or call our Sales Team at +1 347.334.6800 (Americas).

For other regions, fill out the [contact form](#), or find a reseller near you at makerbot.com/resellers.

