

USER MANUAL

K3

CUSTOM[®]

CUSTOM S.p.A.
Via Berettine 2/B
43010 Fontevivo (PARMA) - Italy
Tel. : +39 0521-680111
Fax : +39 0521-610701
http: www.custom.biz

Customer Service Department:
Email : support@custom.it

© 2016 CUSTOM S.p.A. – Italy.
All rights reserved. Total or partial reproduction of this manual in whatever form, whether by printed or electronic means, is forbidden. While guaranteeing that the information contained in it has been carefully checked, CUSTOM S.p.A. and other entities utilized in the realization of this manual bear no responsibility for how the manual is used. Information regarding any errors found in it or suggestions on how it could be improved are appreciated. Since products are subject to continuous check and improvement, CUSTOM S.p.A. reserves the right to make changes in information contained in this manual without prior notification.

The pre-installed multimedia contents are protected from Copyright CUSTOM S.p.A. Other company and product names mentioned herein may be trademarks of their respective companies. Mention of third-party products is for informational purposes only and constitutes neither an endorsement nor a recommendation. CUSTOM S.p.A. assumes no responsibility with regard to the performance or use of these products.

THE IMAGES USED IN THIS MANUAL ARE USED AS AN ILLUSTRATIVE EXAMPLES. THEY COULDN'T REPRODUCE THE DESCRIBED MODEL FAITHFULLY.

UNLESS OTHERWISE SPECIFIED, THE INFORMATION GIVEN IN THIS MANUAL ARE REFERRED TO ALL MODELS IN PRODUCTION AT THE ISSUE DATE OF THIS DOCUMENT.

GENERAL INSTRUCTIONS

CUSTOM S.p.A. declines all responsibility for accidents or damage to persons or property occurring as a result of tampering, structural or functional modifications, unsuitable or incorrect installations, environments not in keeping with the equipment's protection degree or with the required temperature and humidity conditions, failure to carry out maintenance and periodical inspections and poor repair work.

GENERAL SAFETY INFORMATION

Your attention is drawn to the following actions that could compromise the characteristics of the product:

- Read and retain the instructions which follow.
- Follow all indications and instructions given on the device.
- Make sure that the surface on which the device rests is stable. If it is not, the device could fall, seriously damaging it.
- Make sure that the device rests on a hard (non-padded) surface and that there is sufficient ventilation.
- Do not fix indissolubly the device or its accessories such as power supplies unless specifically provided in this manual.
- When positioning the device, make sure cables do not get damaged.
- [Only OEM equipment] The equipment must be installed in a kiosk or system that provides mechanical, electrical and fire protection.
- The mains power supply must comply with the rules in force in the Country where you intend to install the equipment.
- Make sure that there is an easily-accessible outlet with a capacity of no less than 10A closely to where the device is to be installed.
- Make sure the power cable provided with the appliance, or that you intend to use is suitable with the wall socket available in the system.
- Make sure the electrical system that supplies power to the device is equipped with a ground wire and is protected by a differential switch.
- Before any type of work is done on the machine, disconnect the power supply.
- Use the type of electrical power supply indicated on the device label.
- These devices are intended to be powered by a separately certified power module having an SELV, non-energy hazardous output. (IEC60950-1 second edition).
- [Only POS equipment] The energy to the equipment must be provided by power supply approved by CUSTOM S.p.A.
- Take care the operating temperature range of equipment and its ancillary components.
- Do not block the ventilation openings.
- Do not insert objects inside the device as this could cause short-circuiting or damage components that could jeopardize printer functioning.
- Do not carry out repairs on the device yourself, except for the normal maintenance operations given in the user manual.
- The equipment must be accessible on these components only to trained, authorized personnel.
- Periodically perform scheduled maintenance on the device to avoid dirt build-up that could compromise the correct, safe operation of the unit.
- Do not touch the head heating line with bare hands or metal objects. Do not perform any operation inside the printer immediately after printing because the head and motor tend to become very hot.
- Use consumables approved by CUSTOM S.p.A.



THE CE MARK AFFIXED TO THE PRODUCT CERTIFY THAT THE PRODUCT SATISFIES THE BASIC SAFETY REQUIREMENTS.

The device is in conformity with the essential Electromagnetic Compatibility and Electric Safety requirements laid down in Directives 2006/95/CE and 2004/108/CE inasmuch as it was designed in conformity with the provisions laid down in the following Standards:

- EN 55022 Class B (*Limits and methods of measurements of radio disturbance characteristics of Information Technology Equipment*)
- EN 55024 (*Information Technology Equipment – Immunity characteristics – Limits and methods of measurement*)
- EN 60950-1 (*Safety of information equipment including electrical business equipment*)

The device is in conformity with the essential requirements laid down in Directives 1999/05/CE about devices equipped with intentional radiators. The Declaration of Conformity and other available certifications can be request to support@custom.it please providing the correct part number shown on product label or in the invoice.



GUIDELINES FOR THE DISPOSAL OF THE PRODUCT

The crossed-out rubbish bin logo means that used electrical and electronic products shall NOT be mixed with unsorted municipal waste. For more detailed information about recycling of this product, refer to the instructions of your country for the disposal of these products.

- Do not dispose of this equipment as miscellaneous solid municipal waste, but arrange to have it collected separately.
- The re-use or correct recycling of the electronic and electrical equipment (EEE) is important in order to protect the environment and the wellbeing of humans.
- In accordance with European Directive WEEE 2002/96/EC, special collection points are available to which to deliver waste electrical and electronic equipment and the equipment can also be handed over to a distributor at the moment of purchasing a new equivalent type.
- The public administration and producers of electrical and electronic equipment are involved in facilitating the processes of the re-use and recovery of waste electrical and electronic equipment through the organisation of collection activities and the use of appropriate planning arrangements.
- Unauthorised disposal of waste electrical and electronic equipment is punishable by law with the appropriate penalties.



The format used for this manual improves use of natural resources reducing the quantity of necessary paper to print this copy.

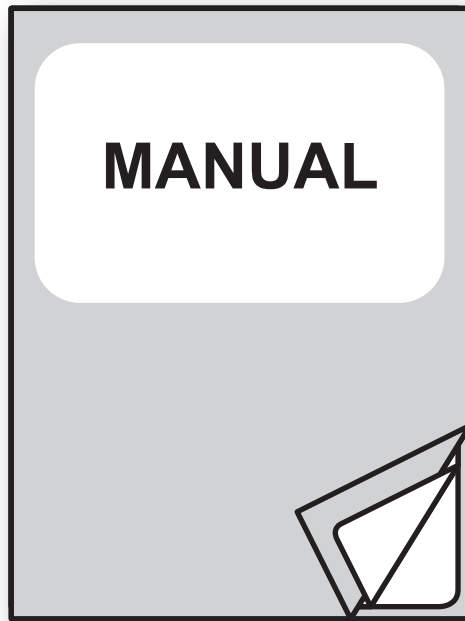

For details on the commands,
refer to the manual with code **77200000002700**

TABLE OF CONTENTS

1	INTRODUCTION	9
1.1	Document structure	9
1.2	Explanatory notes used in this manual	9
2	DESCRIPTION	11
2.1	Box contents	11
2.2	Device components	12
2.3	Product label	14
2.4	Key functions: power up	15
2.5	Key functions: standby	16
2.6	Status led flashes	17
3	INSTALLATION	19
3.1	Wall mounting	19
3.2	Connections	24
3.3	Pinout	25
3.4	Driver and SDK	29
4	OPERATION	31
4.1	Opening the cover	31
4.2	Adjusting the alignment sensor (optional)	32
4.3	Adjusting the paper width (optional)	34
4.4	Switch the device ON/OFF	35
4.5	Loading the paper roll	36
4.6	Loading the fanfold	37
5	CONFIGURATION	39
5.1	Configuration mode	39
5.2	Setup report	40
5.3	Device status	41
5.4	Printer parameters	42
5.5	Ethernet parameters	47
5.6	Hexadecimal dump	48
6	MAINTENANCE	49
6.1	Autocutter paper jam	49
6.2	Planning of cleaning operations	50
6.3	Cleaning	51
6.4	Upgrade firmware	56

7	SPECIFICATION	59
7.1	Hardware specifications	59
7.2	Character specifications	62
7.3	Device dimensions	63
7.4	Power supply dimensions cod. 963GE020000003	65
7.5	Paper specification	66
7.6	Character sets in CUSTOM/POS emulation	70
7.7	True Type fonts	72
8	CONSUMABLES	73
9	ACCESSORIES	75
10	ALIGNMENT	77
10.1	Enable alignment	78
10.2	Calibration	81
10.3	Alignment parameters	84
10.4	Printing area	87
11	TECHNICAL SERVICE	89
12	ADVANCED FUNCTIONS	91
12.1	File sharing	91
12.2	Drivers installation	92
12.3	Logos management	93
12.4	Fonts management	94
12.5	Setup	95

1 INTRODUCTION

1.1 Document structure

This document includes the following chapters:

1	INTRODUCTION	information about this document
2	DESCRIPTION	general description of device
3	INSTALLATION	information required for a correct installation of the device
4	OPERATION	information required to make the device operative
5	CONFIGURATION	description of the configuration parameters of the device
6	MAINTENANCE	information for a correct periodic maintenance
7	SPECIFICATION	technical specification for the device and its accessories
8	CONSUMABLES	description and installation of the available consumables for the device
9	ACCESSORIES	description and installation of the available accessories for the device
10	ALIGNMENT	information required for managing the paper alignment
11	TECHNICAL SERVICE	information required for contacting the technical service
12	ADVANCED FUNCTIONS	information about special functions available with the device

1.2 Explanatory notes used in this manual

NOTE:

Gives important information or suggestions relative to the use of the device

ATTENTION:

Gives information that must be carefully followed to guard against damaging the device

DANGER:

Gives information that must be carefully followed to guard against operator injury or damage

2 DESCRIPTION

2.1 Box contents

Remove the device from its carton being careful not to damage the packing material so that it may be re-used if the device is to be transported in the future.

Make sure that all the components illustrated below are present and that there are no signs of damage. If there are, contact Customer Service.

1. Device
2. AC adapter
3. AC Power cable
4. Short guide

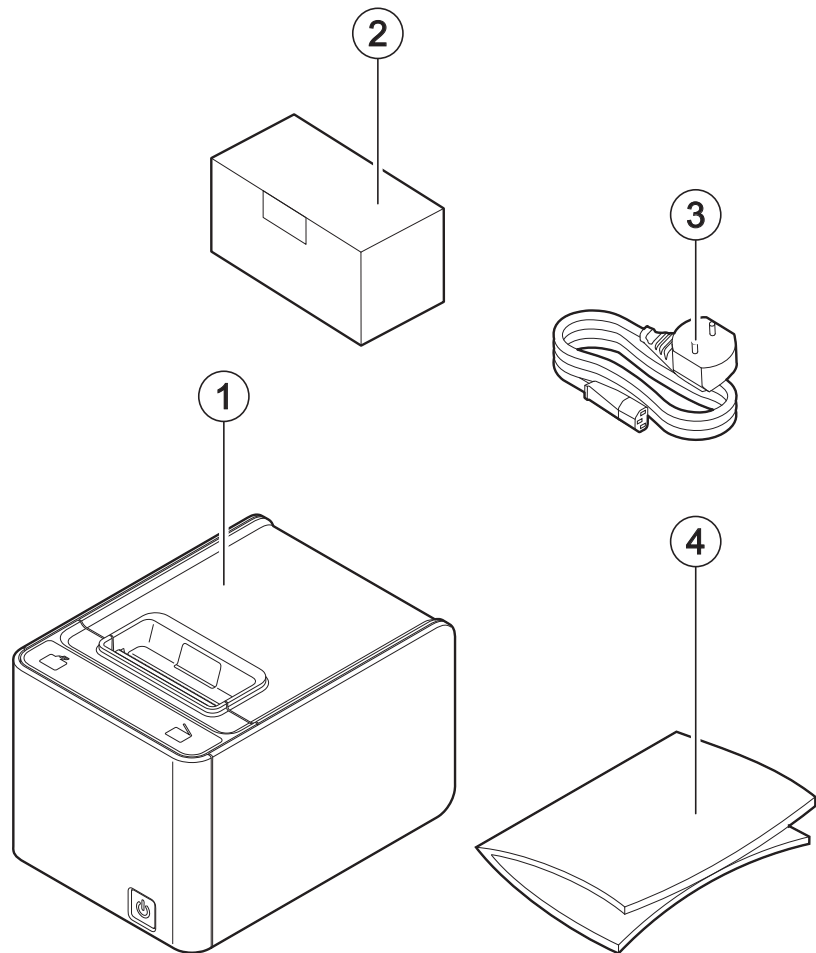

- Open the device packaging.
- Remove the packing frame content and remove the packing frame.
- Take out the device.
- Keep the box, trays and packing materials in the event the device must be transported/shipped in the future.

2.2 Device components

External view

1. Paper compartment
2. Service button for cover opening
3. Paper out with serrated blade
4. FEED key
5. OPEN key
6. Front cover
7. ON/OFF key
8. Opening levers of cables compartment
9. Cables compartment
10. Button for front cover release
11. Entrance for fanfold
12. Power supply port
13. RS232 serial interface port
14. USB interface port
15. Ethernet interface port
16. Drawer port
17. Customer display (optional)

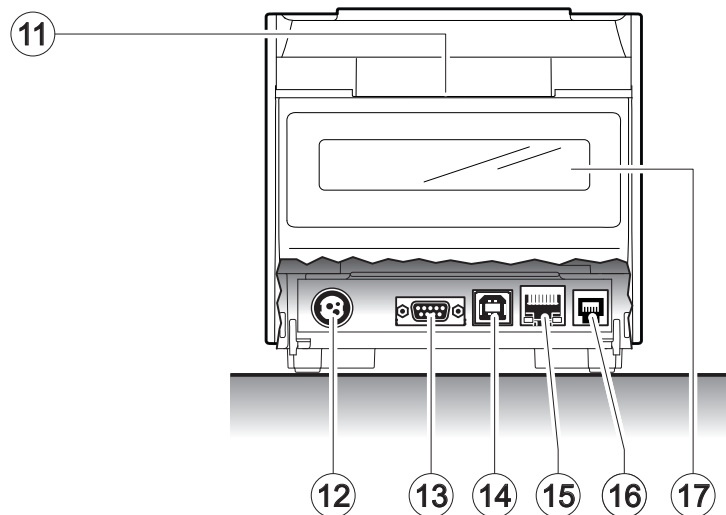
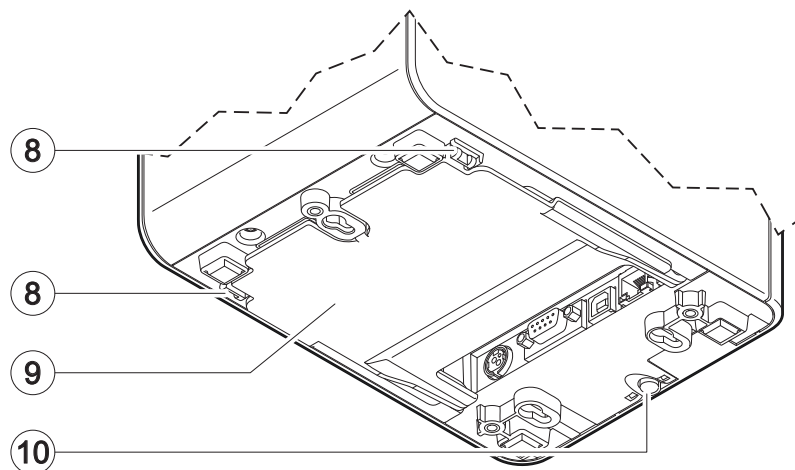
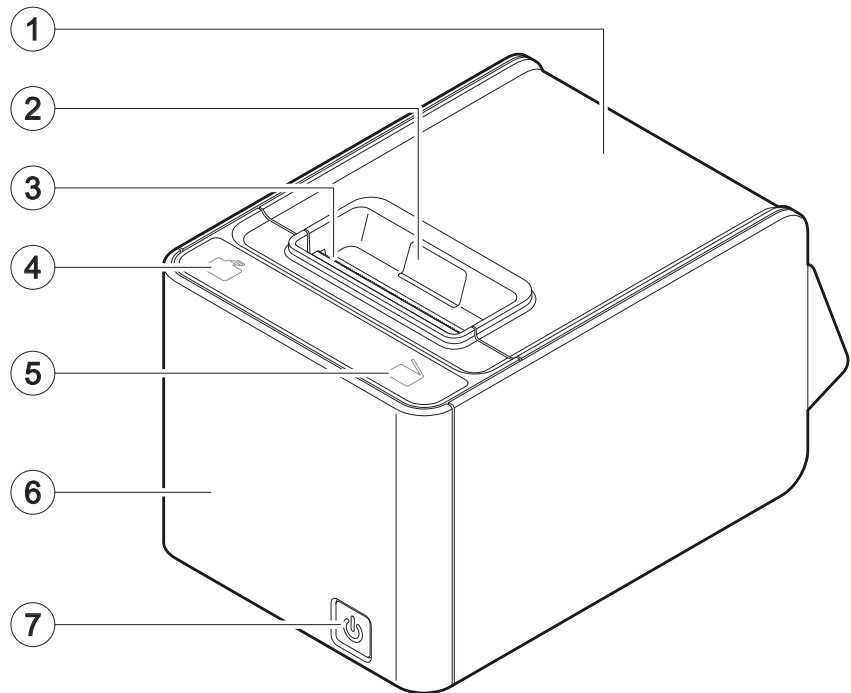

Internal view

1. System with three sensors for detecting black mark or hole on the non-thermal side of the paper (optional)
2. Sensor for paper and black mark detection
3. Sensor for cover open
4. Mobile sensor for detecting black mark or hole on the thermal side of the paper (optional)
5. Sensor for detecting low paper, adjustable in 2 positions (a = device in the normal position, b = device mounted on the wall)
6. Temperature sensor for the print-head

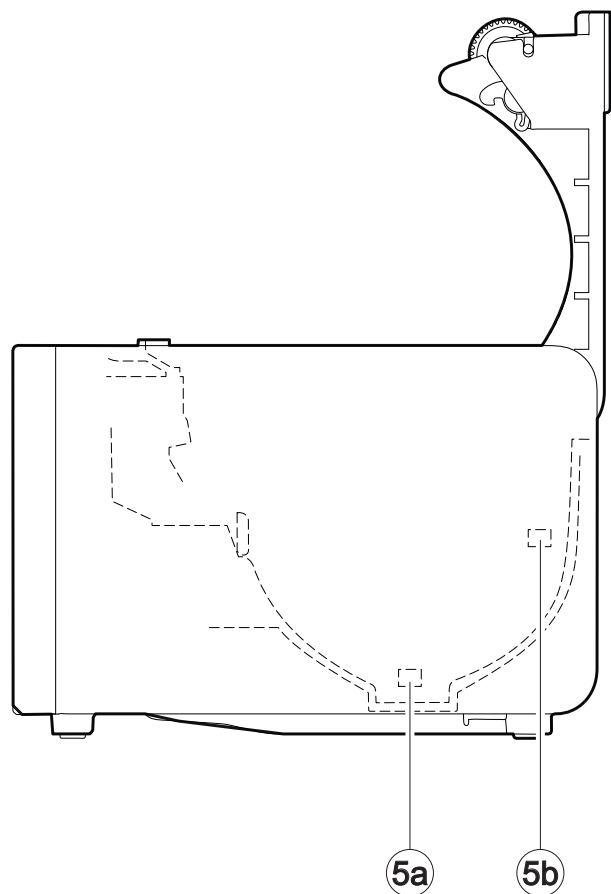
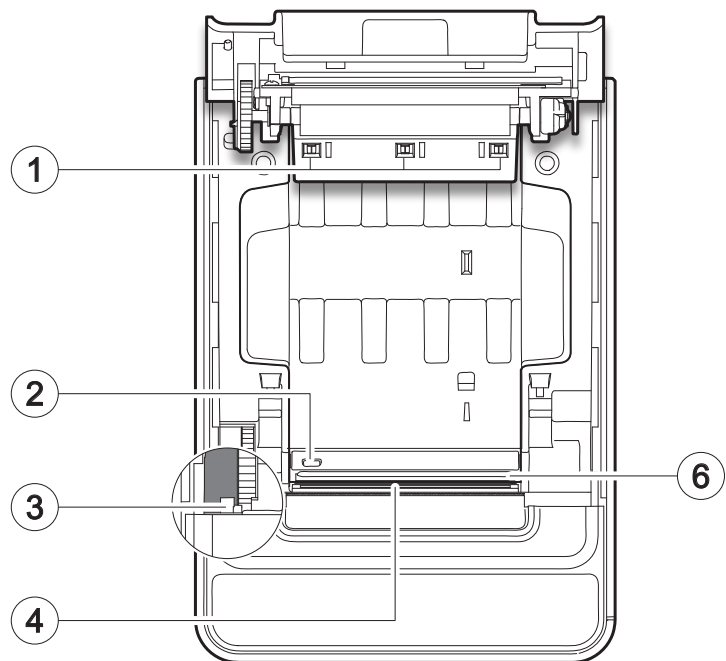

2.3 Product label

PC = Product code (14 digits)
SN = Serial number
HW = Hardware release

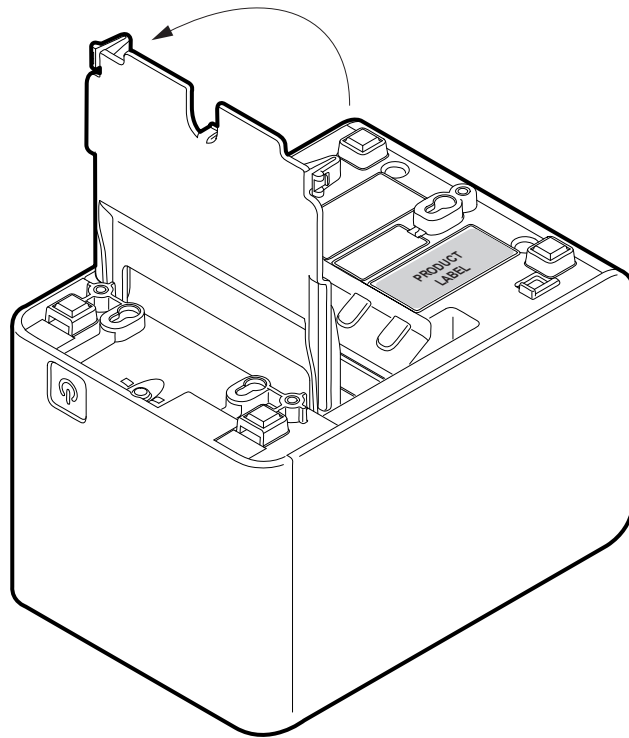
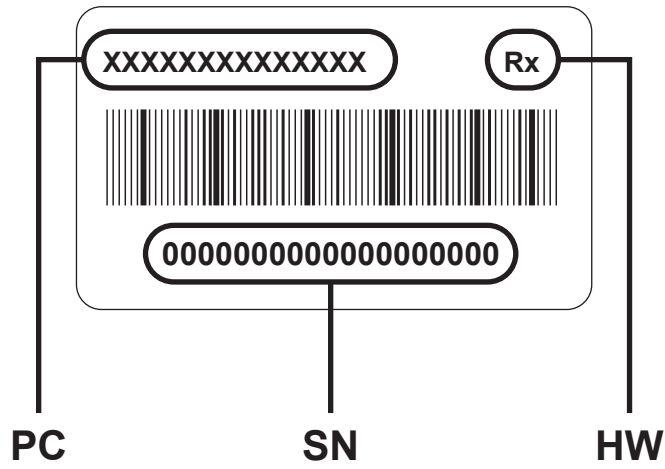

2.4 Key functions: power up

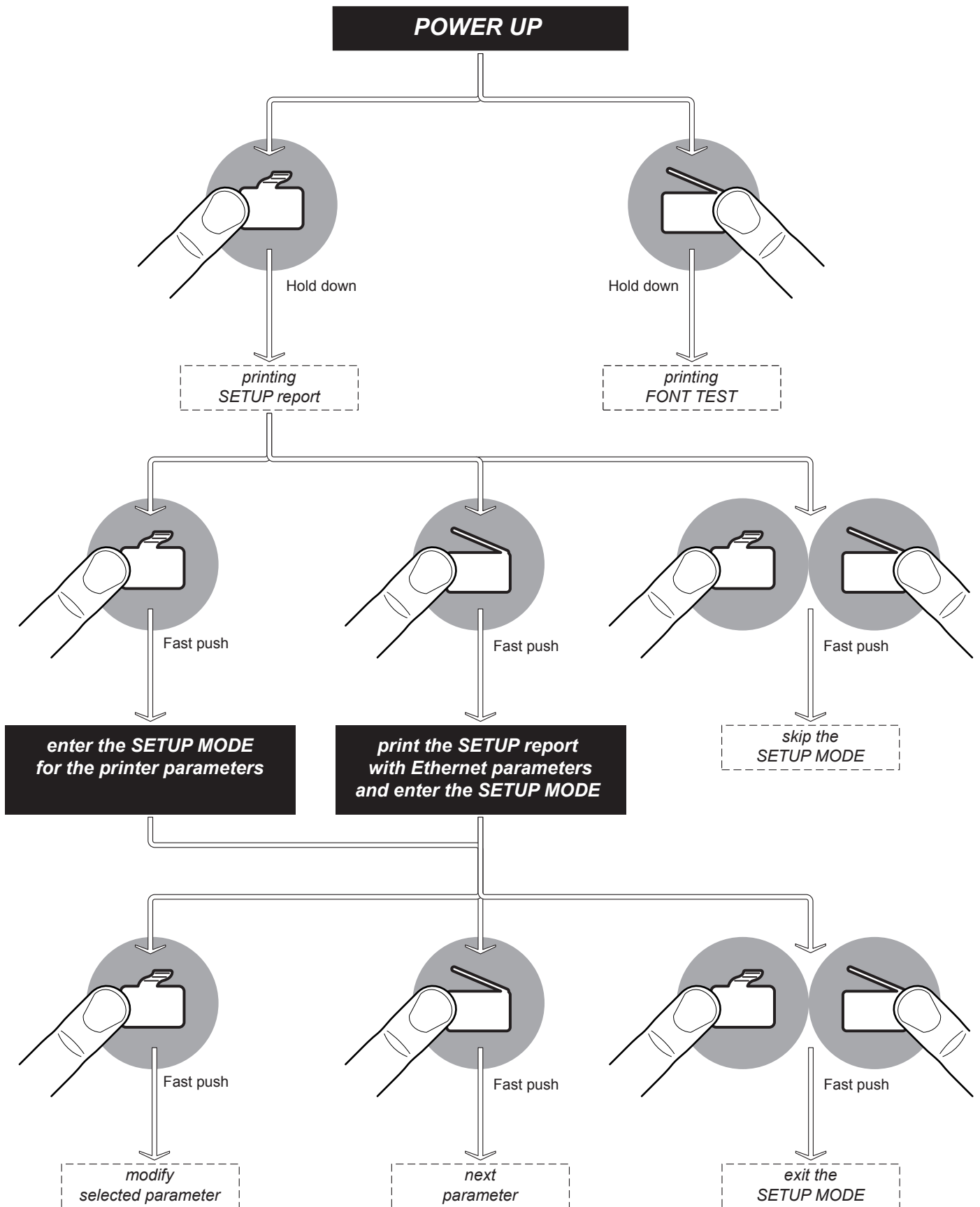



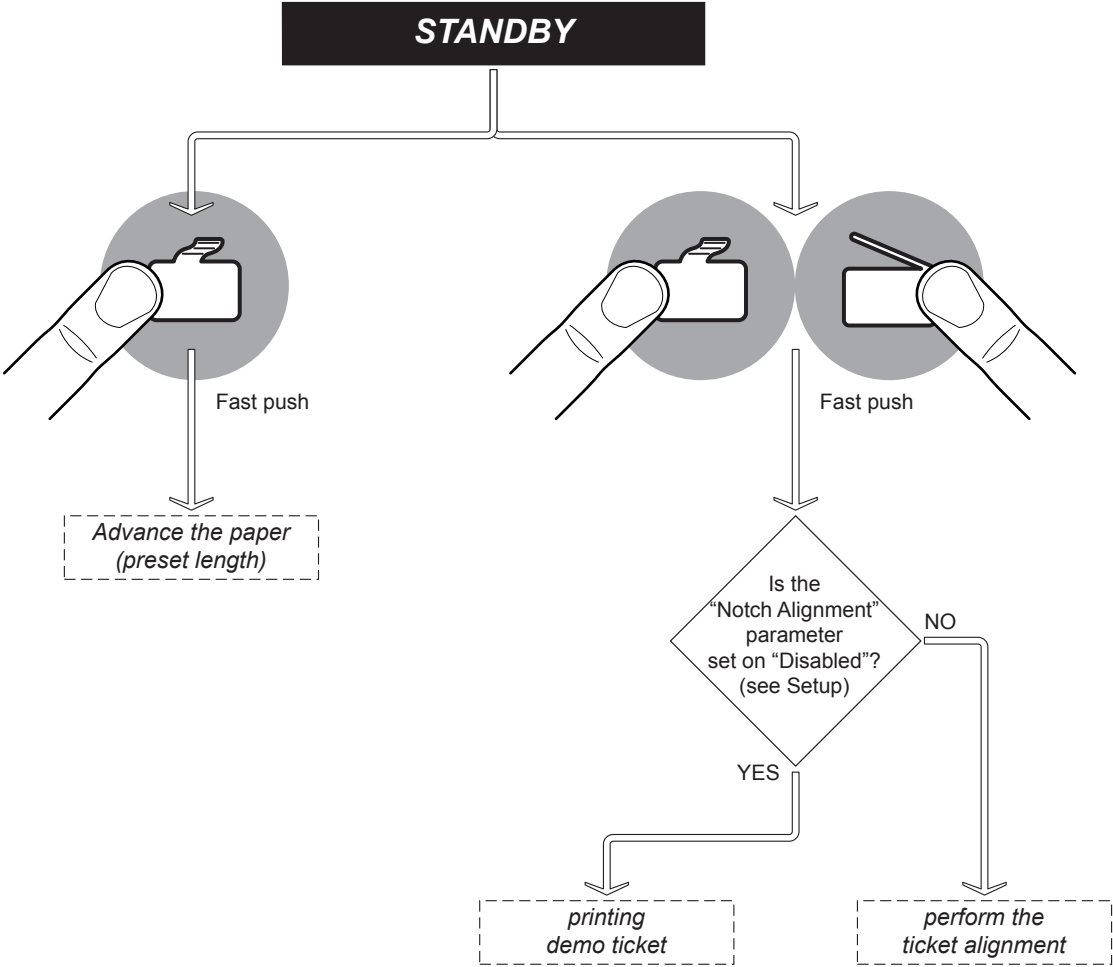

2.5 Key functions: standby



2.6 Status led flashes

The Status led indicates hardware status of device. Given in the table below are the various led signals and the corresponding device status.

STATUS LED		DESCRIPTION	
-		OFF	DEVICE OFF
BLUE NOTIFICATION STATUS		ON	DEVICE ON: NO ERROR
BLUE COMMUNICATION STATUS		1 x	RECEIVE DATA
		2 x	RECEPTION ERRORS (PARITY, FRAME ERROR, OVERRUN ERROR)
		3 x	COMMAND NOT RECOGNIZED
		4 x	COMMAND RECEPTION TIME OUT
		5 x	LOW PAPER
PURPLE RECOVERABLE ERROR		2 x	HEADING OVER TEMPERATURE
		3 x	PAPER END
		5 x	POWER SUPPLY VOLTAGE INCORRECT
RED UNRECOVERABLE ERROR		6 x	COVER OPEN
		3 x	RAM ERROR
		4 x	EXTERNAL FLASH ERROR
		5 x	CUTTER ERROR

3 INSTALLATION

3.1 Wall mounting

The device is equipped with a double vertical mounting capability of the machine:

- Setup 1: Three threaded holes for mounting with M4 screws
- Setup 2: Three slots for mounting on pins.

Both arrangements are placed at the bottom of the machine (see figure below). The dimensions shown in the image are expressed in millimetres.

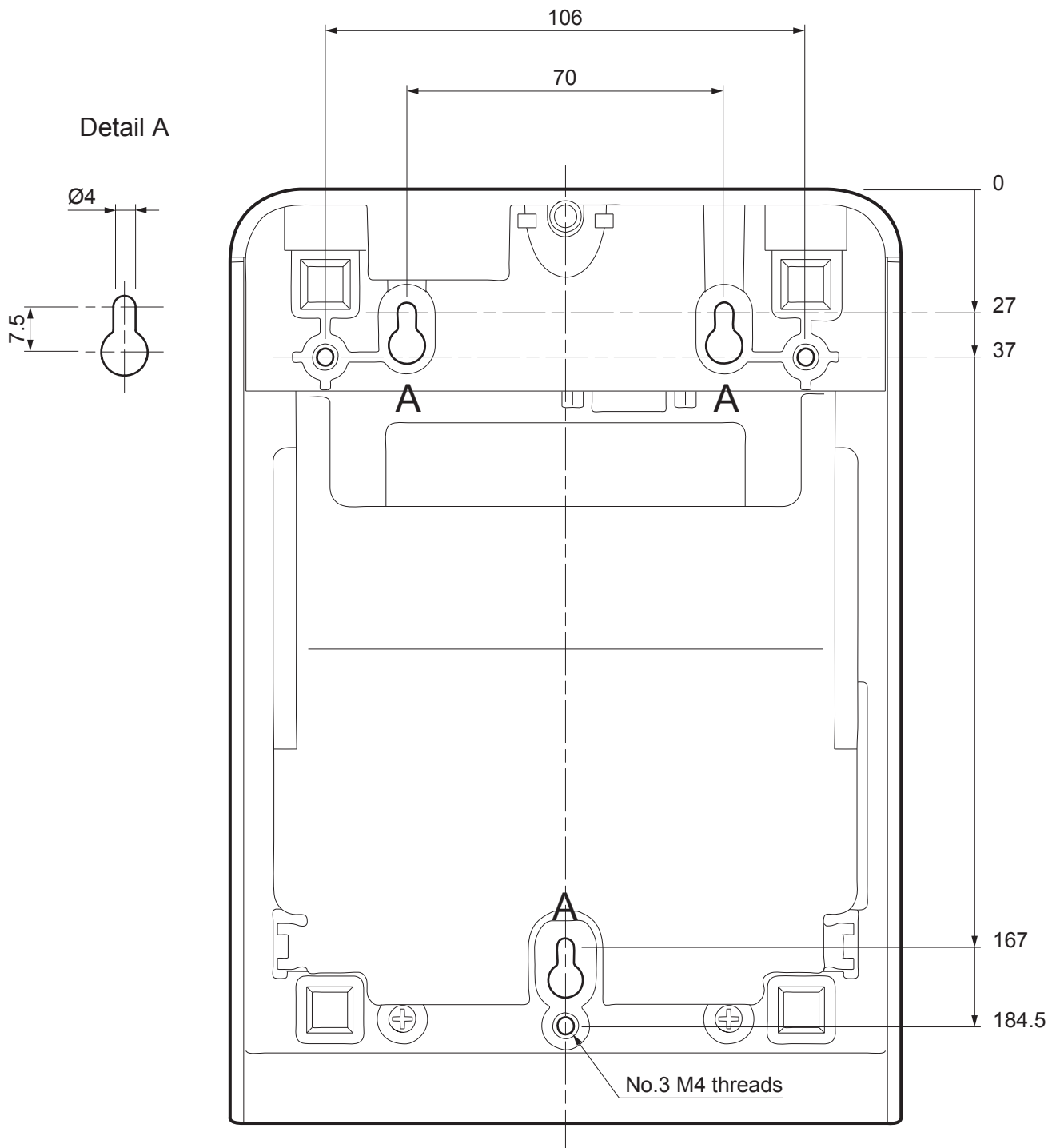

Guidelines for wall mounting with M4 screws

Drill holes in the fixing panel using the measurements shown on the previous page. Pay attention to the length of the screws used.

The screw length (L) will be calculated according to the thickness of the panel (SP) on which the device is fixed, as follows

$$L \leq 6 \text{ mm} + SP$$

For example, if panel thickness is 10 mm (SP = 10 mm), the max screw length will be 16 mm.

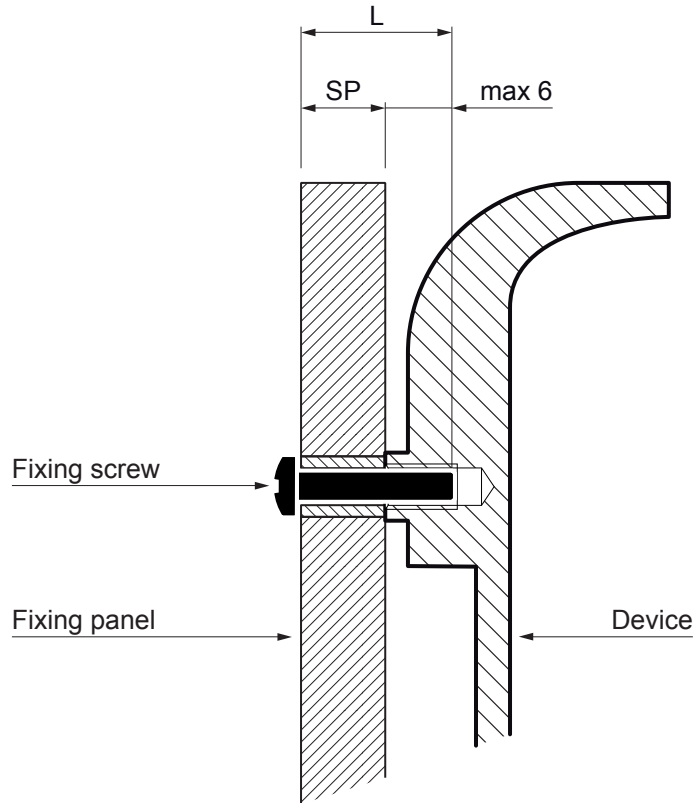

Guidelines for wall mounting on pins

Attach three pins to the wall using the measurements shown on the previous page. The dimensions of the fixing pins are provided below. The dimensions shown in the image are in millimetres.

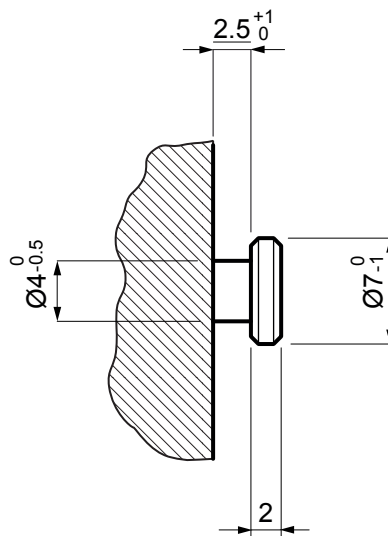

Mounting

1

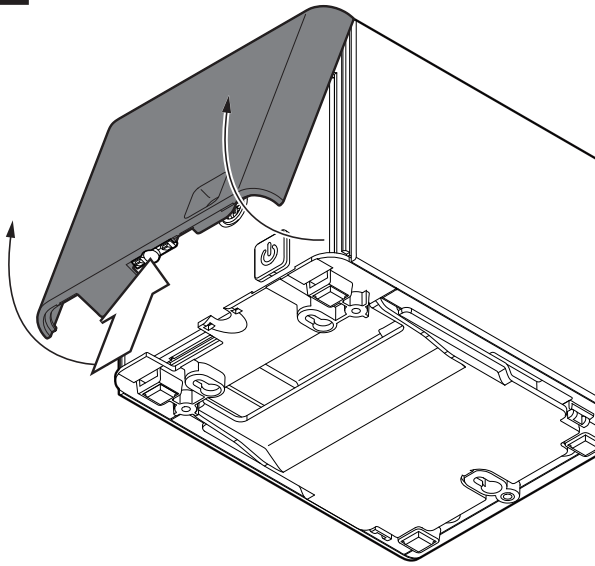

Press the release button and remove the front cover

2

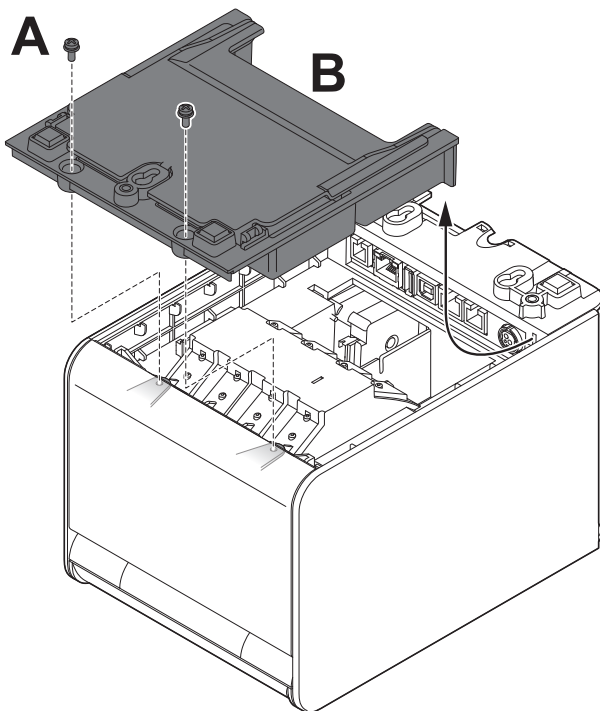

Turn the device upside down and unscrew the 2 fixing screws A. Remove the base B of the device by pulling it out from the seats in the direction shown.

3

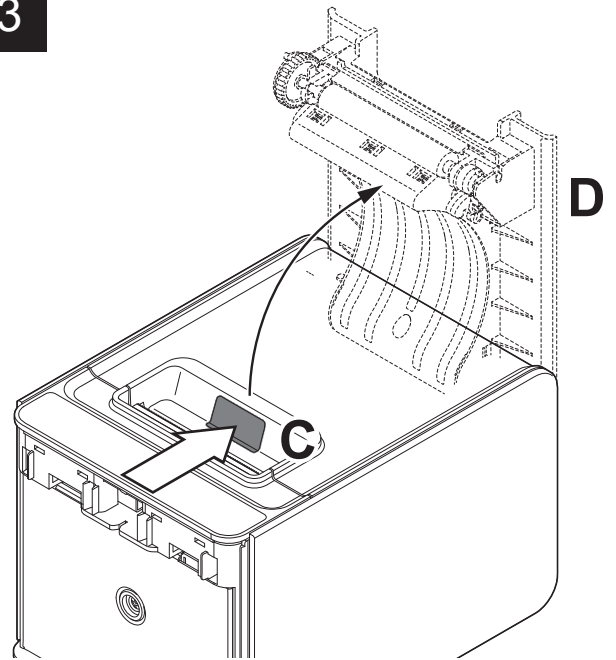

Press the service button C to open the device cover D

4

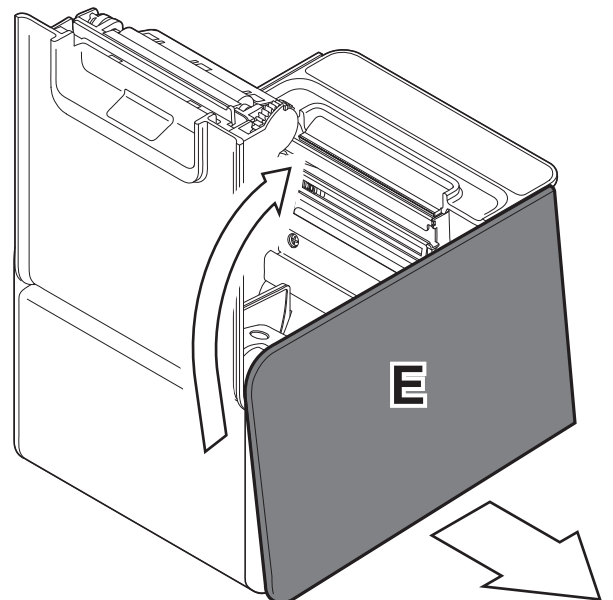

Pull the lower part of the side E. Rotate the rear to release it from its seats on the frame

5

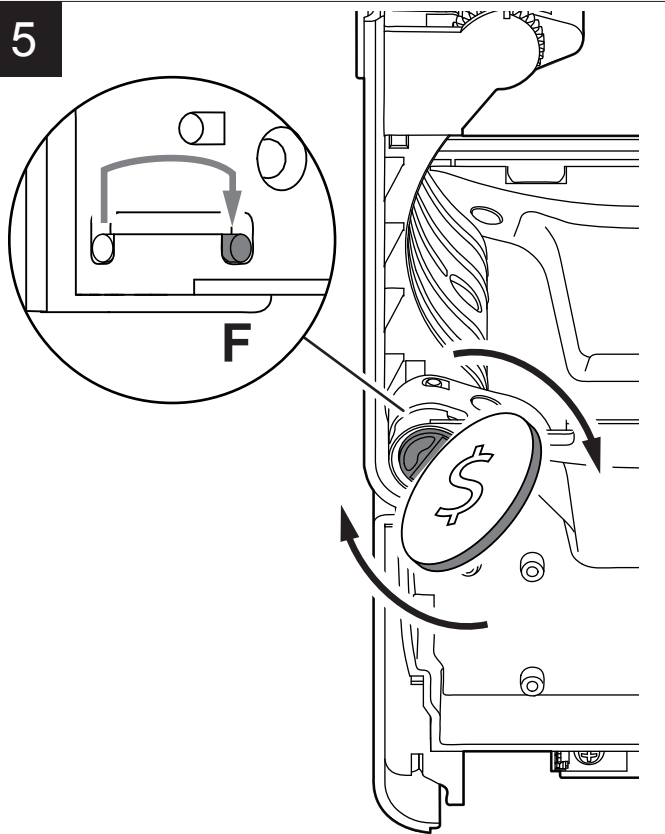

Rotate the selector that adjusts the load on the return spring for the cover in position F by using a coin

7

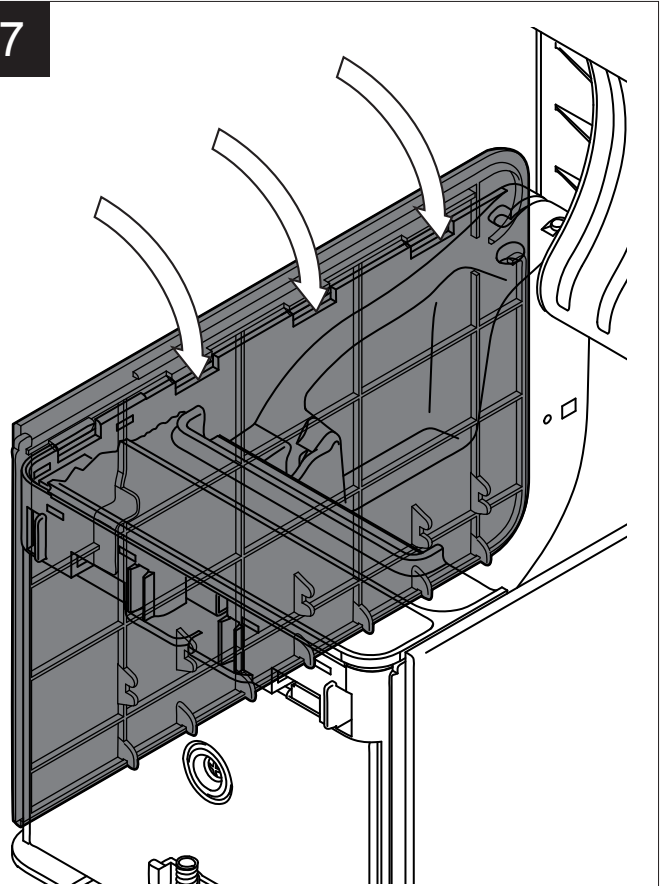

Turn down the side to lock the other pins in its seats on the frame.

6

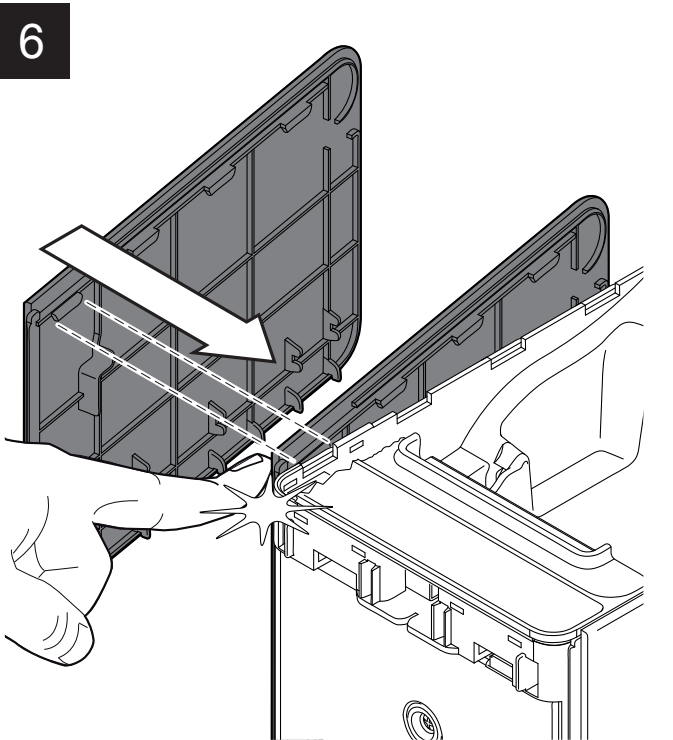

Tilt the side and insert the pin into its seat on the frame. Press in the specified position to lock the pin.

8

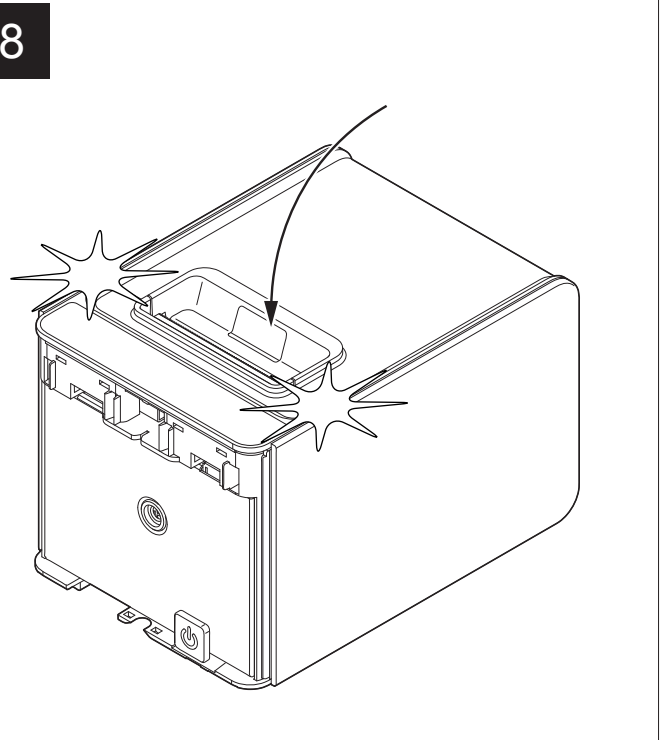

Close the device cover

9

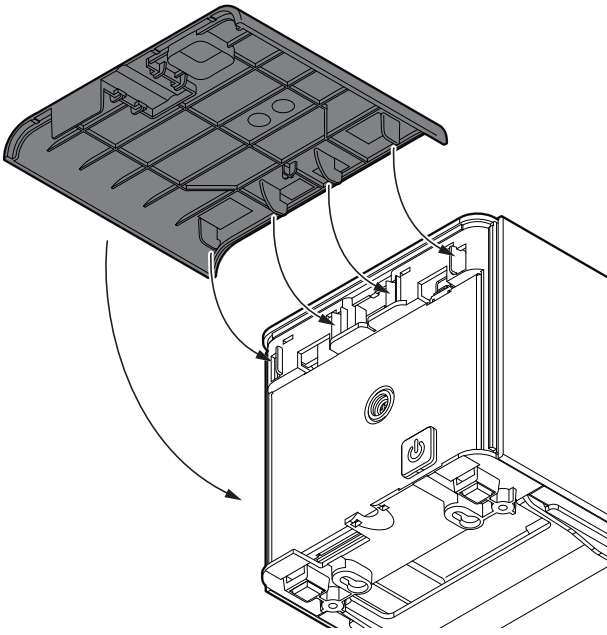

Reassemble the cover removed previously

10

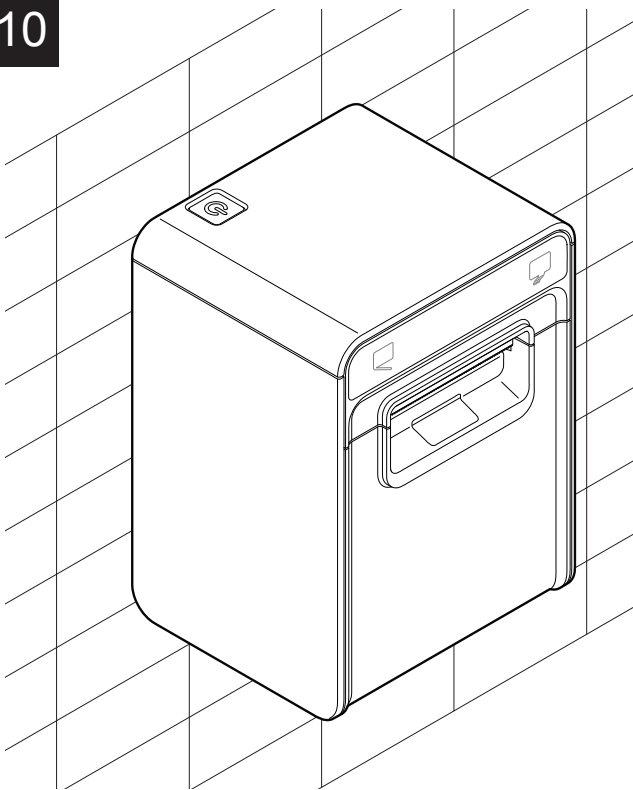

Fix the device to the wall

3.2 Connections

The following figure shows the possible connections for the device.

ATTENTION:

In some using conditions, we recommend the installation of a ferrite core on the power supply cable.

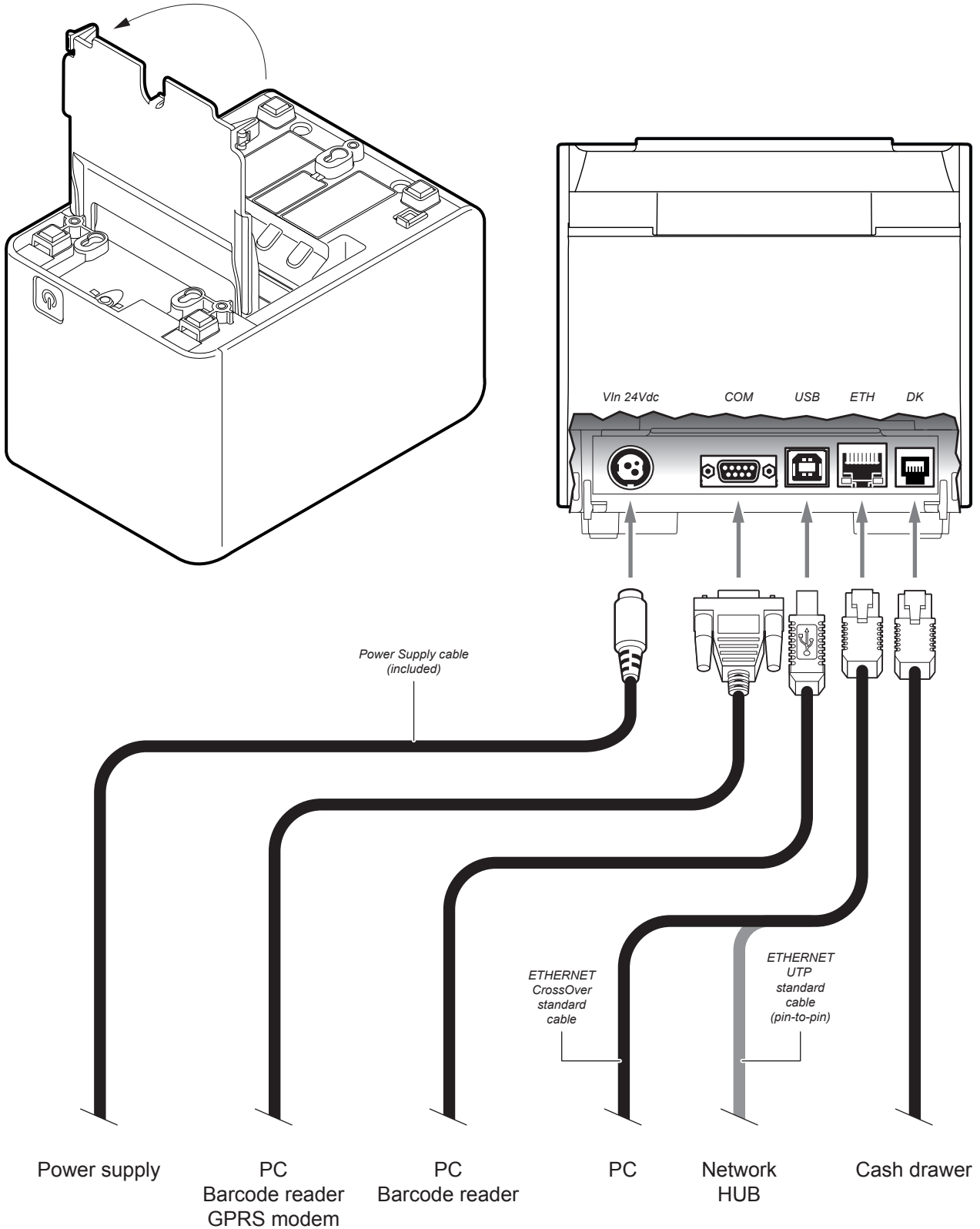

3.3 Pinout



POWER SUPPLY
Tripolar female connector

J1	1	+24 Vdc
	2	GND
	3	GND
	4	Frame GND

ATTENTION:
Respect power supply polarity.

NOTE:
Power supply cable
The following figure shows the connector pinout of the power supply cable for the device:

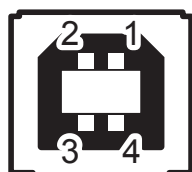
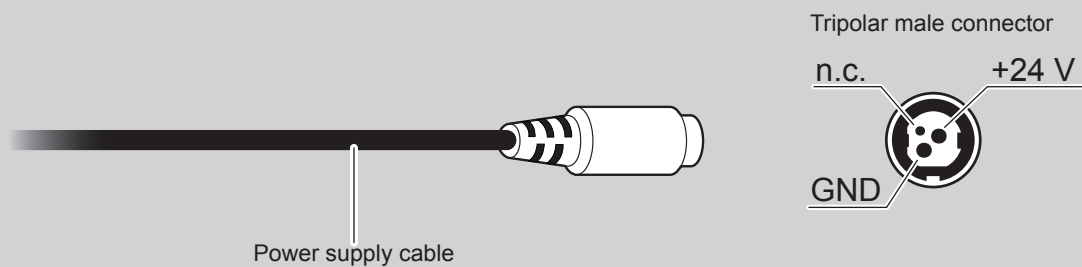

USB INTERFACE
Female USB type B connector

J4	1	USB0-VBUS	(in)
	2	D0 -	(in/out)
	3	D0 +	(in/out)
	4	GND	
	SH1	SHIELD	
	SH2	SHIELD	

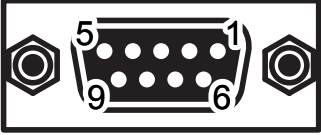

RS232 SERIAL INTERFACE

Female DB9 connector

J3	1	DTR	
	2	TX	During transmission, takes the values "0" and "1" depending on data.
	3	RX	During reception, takes the values "0" and "1" depending on data.
	4	DSR	
	5	GND	
	6	DTR	When "1", device is power on.
	7	CTS	
	8	RTS	When "1", device is ready to receive data
	9	n.c.	

NOTES:

Given the presence of the RS232 standard, logic value "0" corresponds to a voltage level of between +3Vdc and +15Vdc and logic value "1" corresponds to a voltage level of between -3Vdc and -15Vdc.

K3 > PC connection

The following picture shows an example of connections between the device and a personal computer using a 9 pin RS232 serial connectors:

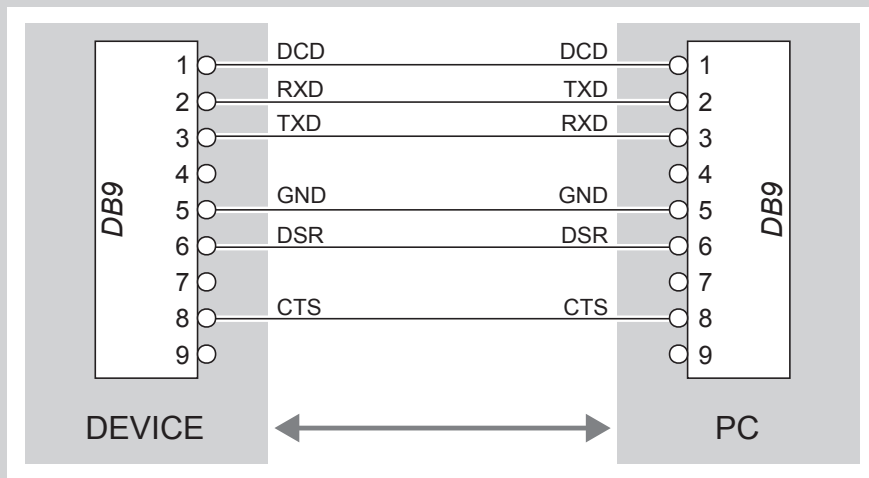

When use a serial cable, we recommend the installation of a ferrite core on the power supply cable.

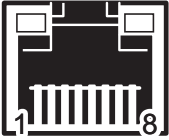

ETHERNET INTERFACE

Female RJ45 connector

J5	1	TPOUT +
	2	TPOUT -
	3	TPIN +
	4	GND
	5	GND
	6	TPIN -
	7	n.c
	8	n.c
	9	+3.3 V
	10	LED-LAN
	11	+3.3 V
	12	LED-LNK
	13	Shield
	14	Shield

NOTES:

The functionality of two led are specified in the following table:

LED	FUNCTION
LED-LNK	Link (yellow color): the led lights up when a connection is active
LED-LAN	Rx/Tx: (green color): the led lights up when occurs a data reception or transmission

- To directly connect the device to a Personal Computer, use a Cross-Over Ethernet cable.
- To connect the device to a hub device, use an UTP Ethernet cable (Pin to Pin).

The pinout shown in table represents the input signals to component J5 before the isolation voltage transformer (through-hole pin).



DRAWER CONNECTOR

Female RJ12 connector

J2	1	GND		
	2	SOL1	(out)	Drawer 1 command (open collector)
	3	CASS	(in)	Drawer status
	4	+24 Vdc		
	5	SOI2	(out)	Drawer 2 command (open collector)
	6	GND		

ATTENTION:

This device can manage drawers of different power supplies (6V, 12V, 18V, 24V). To prevent a current overload, check and set correctly the kind of cash drawer.

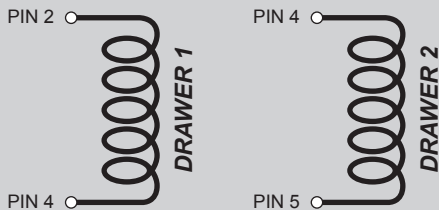

NOTE:

The solenoid of the drawer 1 must be connected from Pin 2 to Pin 4 on the drawer connector

The solenoid of the drawer 2 must be connected from Pin 4 to Pin 5 on the drawer connector

NOTE:

K3 > CASH DRAWER (optional) connection

Use an optional adapter cable RJ12-Jack to connect the device to a cash drawer. Refer to the picture below for the connector pin signals

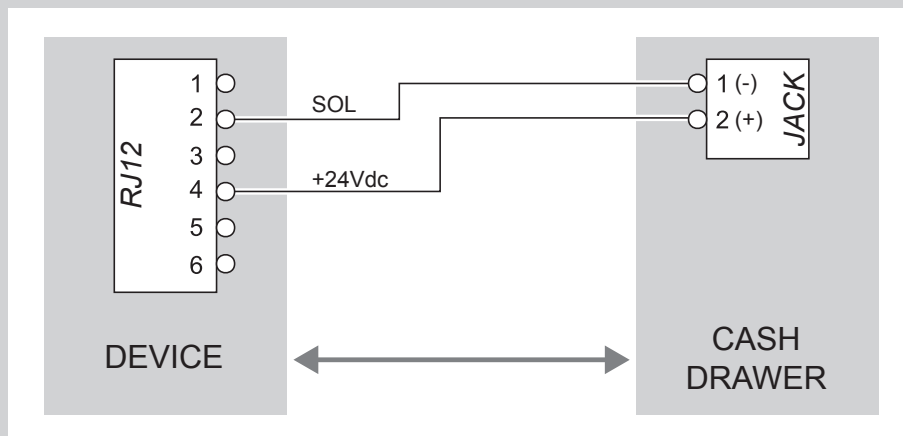

3.4 Driver and SDK

The drivers are available for the following operating system:

OPERATING SYSTEM	DESCRIPTION	INSTALLATION PROCEDURE
Windows	Driver for Windows XP	From the START menu, press Run and type-in the path where the SW was saved on your PC, then click OK. Follow the instructions that appear on the screen to install the driver.
	Driver for Windows VISTA (32/64bit)	
	Driver for Windows 7 (32/64bit)	
	Driver for Windows 8 (32/64bit)	
	Driver for OPOS	
Linux		Follow the instruction get back on the README.TXT file. You can find it in the software package downloaded in advance.
Windows / Linux	Driver for JavaPOS	Extract the zipped folder to the destination path desired.
Android	Library for CustomAndroidAPI	Extract the zipped folder to the destination path desired. Follow the instructions present in the software package that you downloaded on how to install and use the library.
iOS	Library for CustomiOSApi	Extract the zipped folder to the destination path desired. Follow the instructions present in the software package that you downloaded on how to install and use the library.
Windows Phone 8	Library for CeWP8Api	Extract the zipped folder to the destination path desired. Follow the instructions present in the software package that you downloaded on how to install and use the library.

NOTA:

All drivers can be found in the DOWNLOAD section of the web site www.custom.biz.

4 OPERATION

4.1 Opening the cover

Automatic

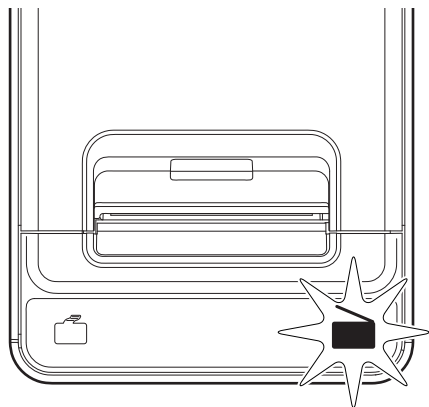
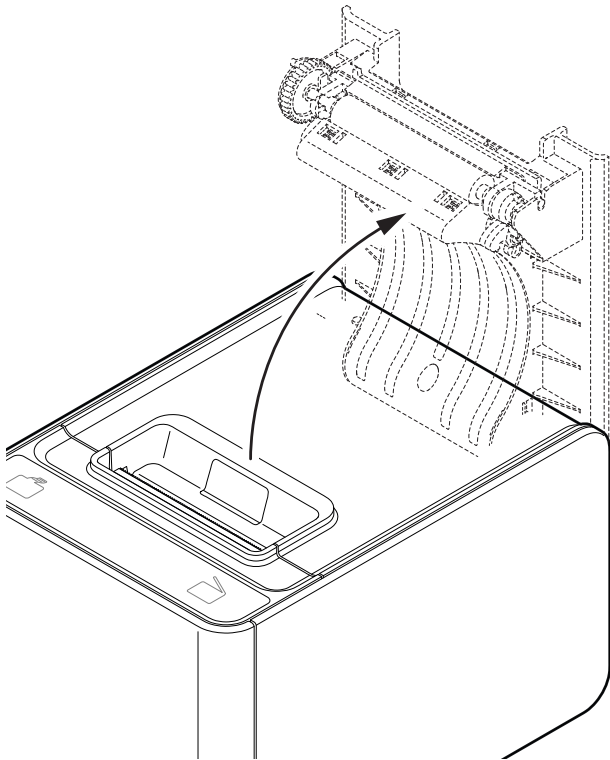

The cover-opening mechanism is automatically triggered as soon as the roll runs out in order to prompt the user to replace it.
The indicator shows the state "Paper end"

Manual

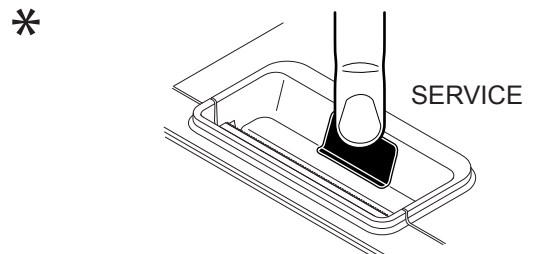
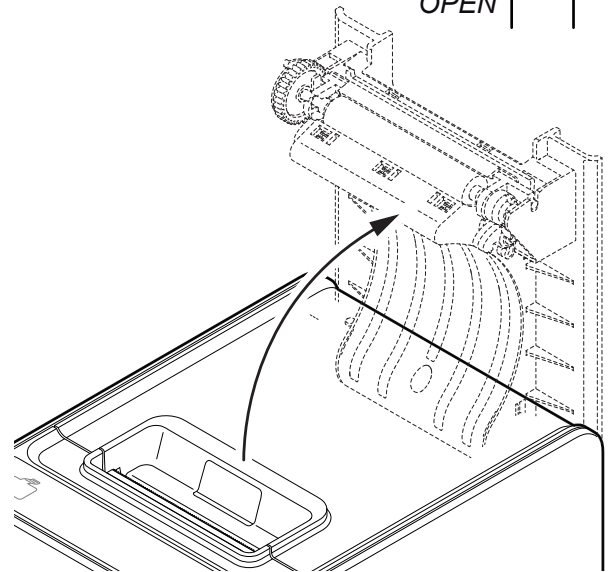
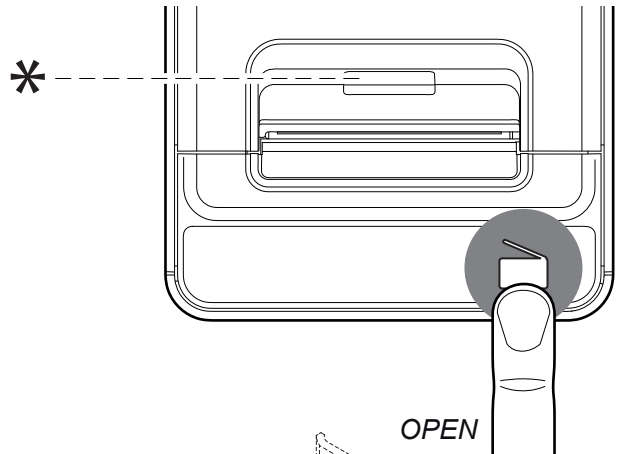

Press and hold the OPEN button to open the device cover.
Or in case of anomalies press the service button.

4.2 Adjusting the alignment sensor (optional)

The device can be optionally equipped with a mobile sensor for the detection of the alignment black mark placed on the thermal side of paper as shown below.

The device user will need to manually move this mobile sensor according to the position of the black mark on the paper (see next paragraphs).

To use this sensor for black mark detection, you must set the "Notch/B.Mark Position" setup parameter on the "Bottom" value (see Chapter 5).

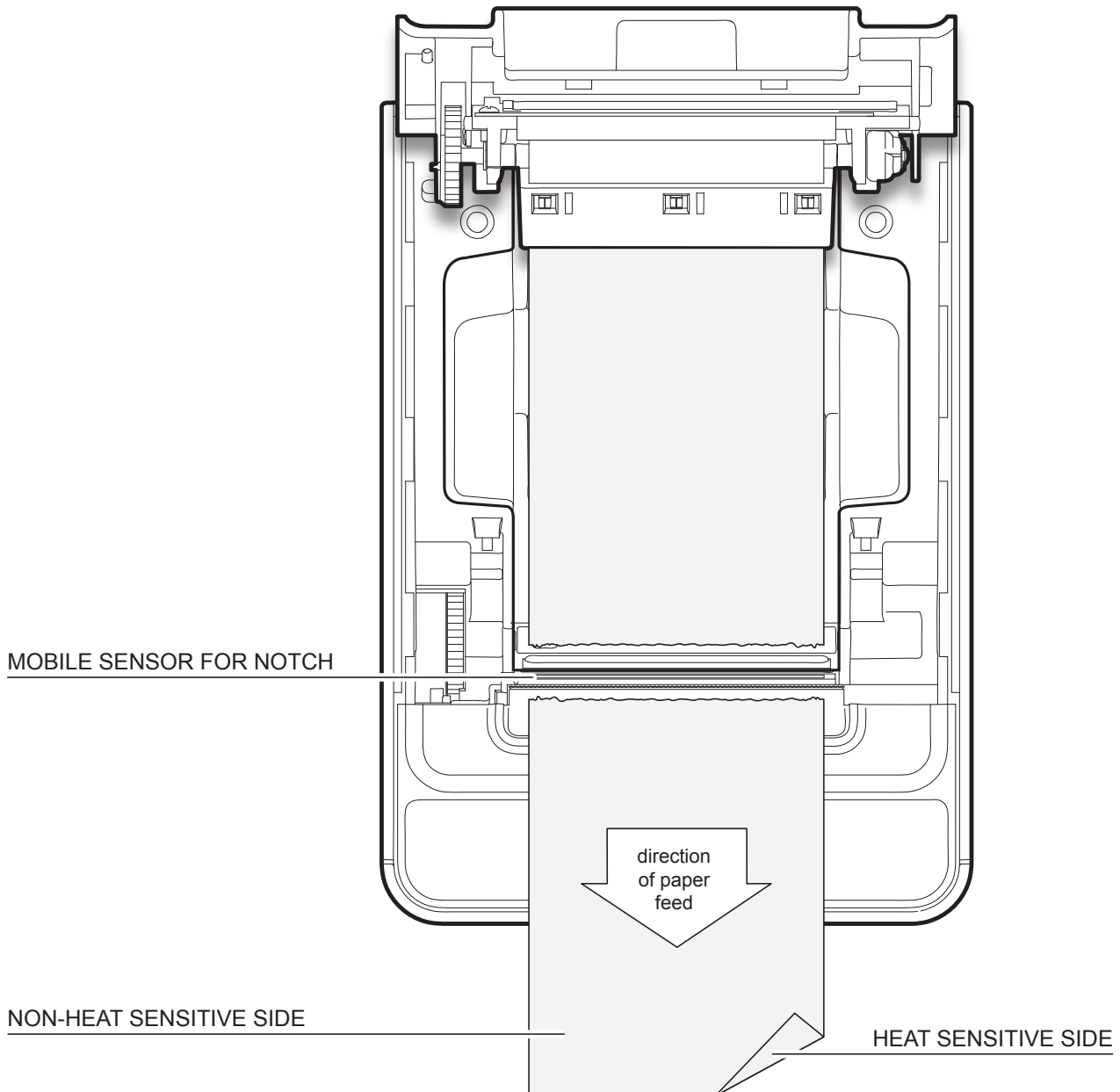

To adjust the mobile sensor position according to the black mark position on paper, open the device cover (see par. 4.1) and move the sensor to the desired position using a small screwdriver or a pointed object.

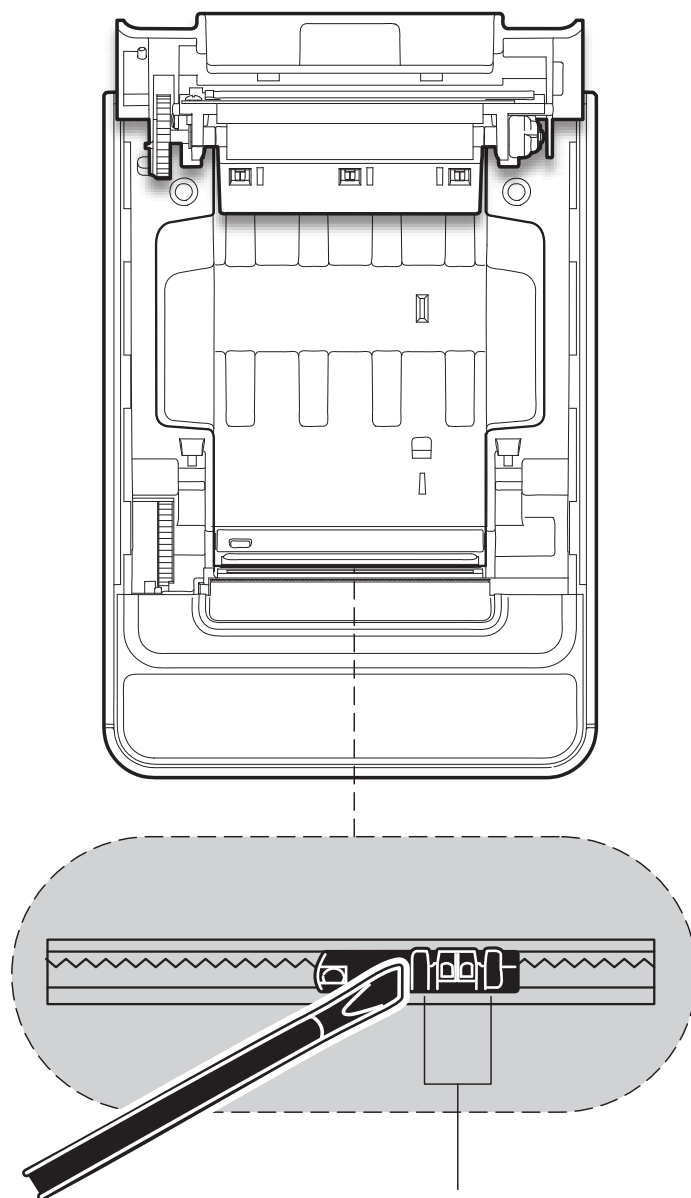

ATTENTION:
To avoid damaging the sensor,
use the plastic tabs as foothold
for the screwdriver to push
the sensor in the desired position.

4.3 Adjusting the paper width (optional)

The device can be optionally equipped with an adapter for the regulation of paper width to use. To adjust the paper width, proceed as follows.

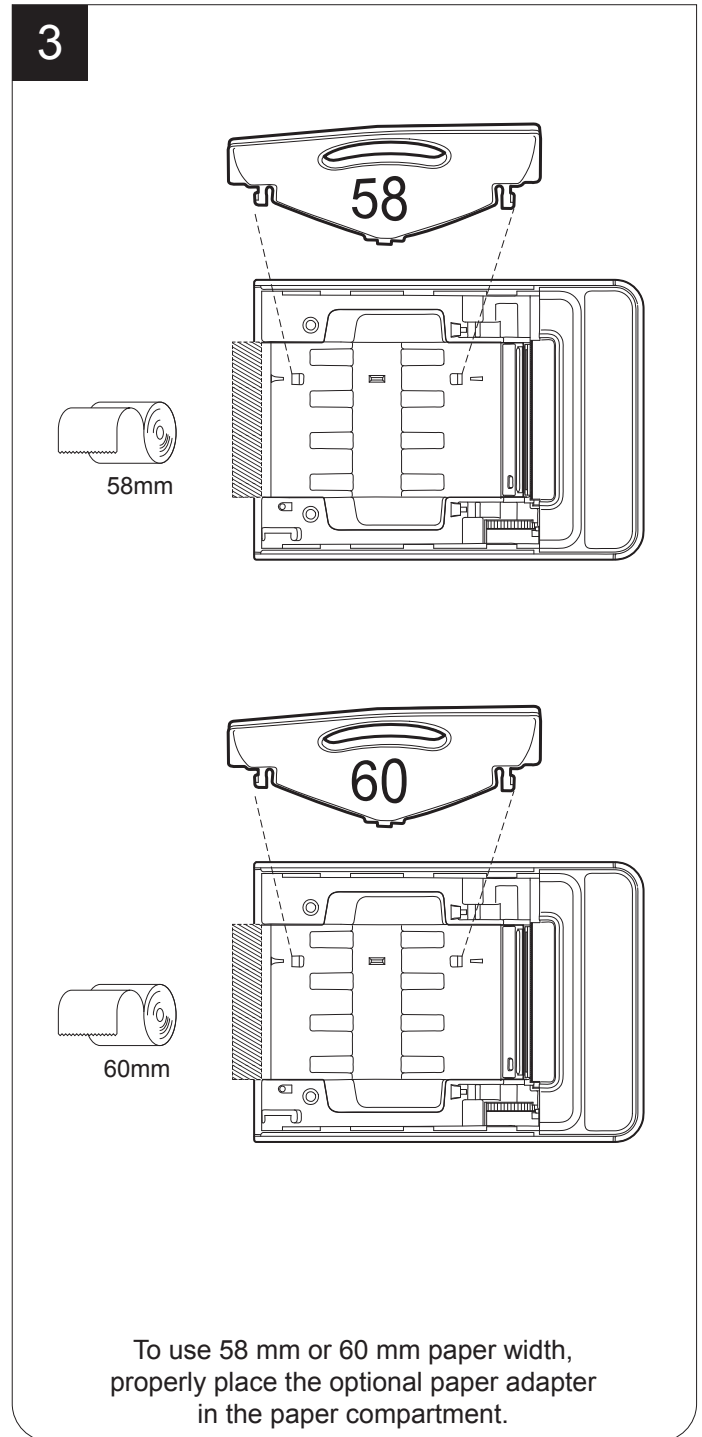
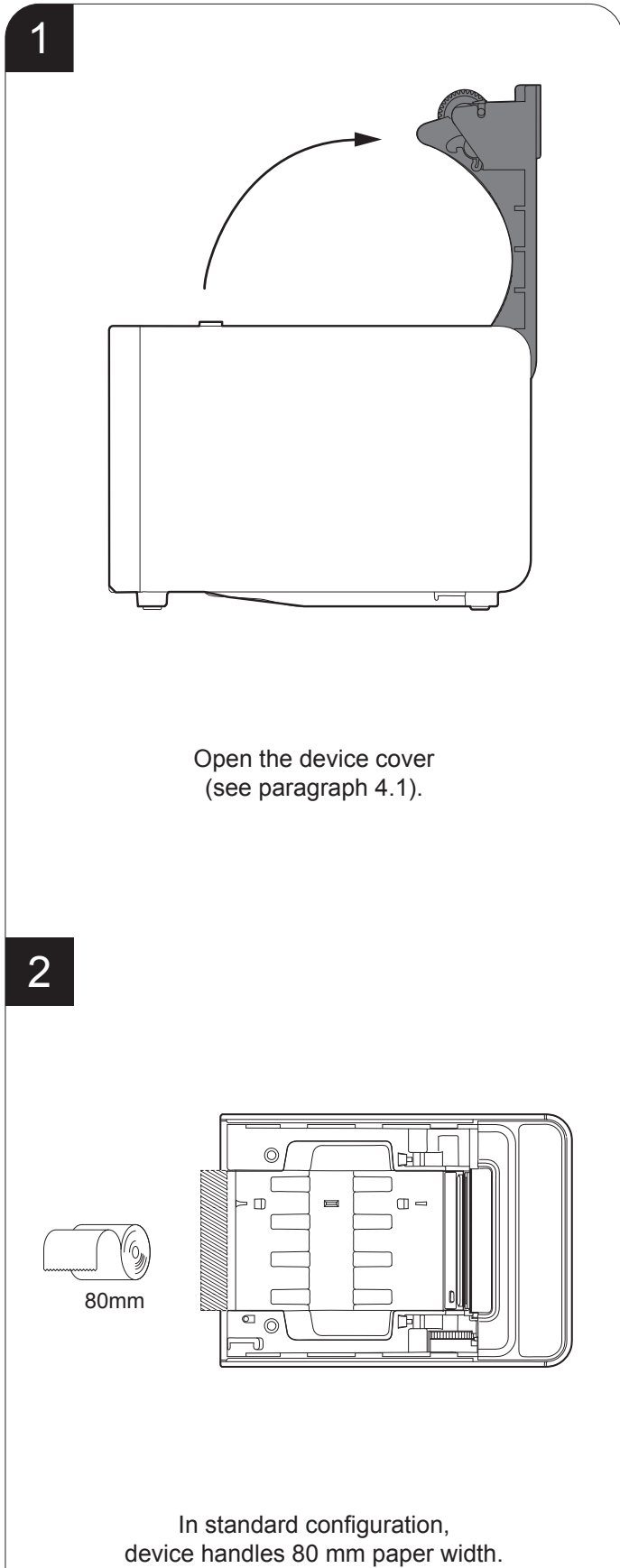

4.4 Switch the device ON/OFF

1

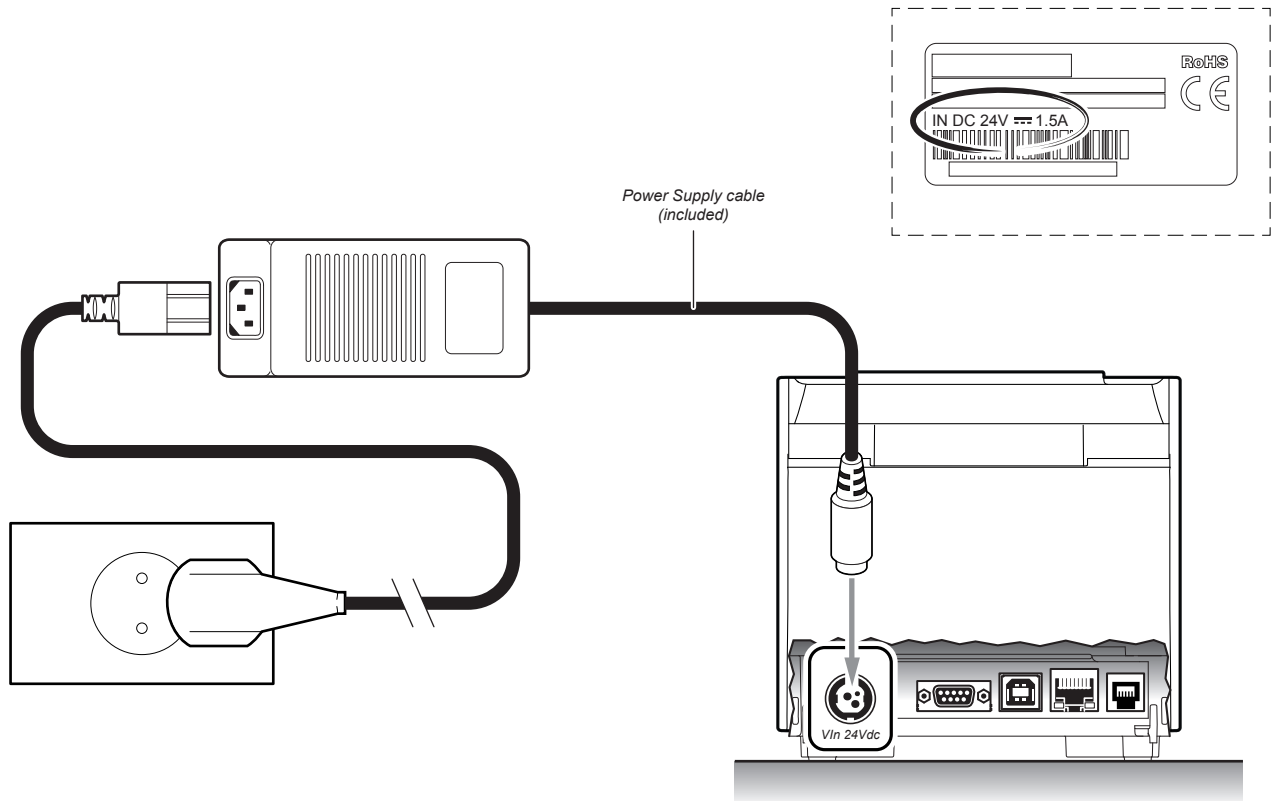

Connect the power adapter (supplied) to the device and the mains outlet.
Use the type of electrical power supply indicated on the label.

2

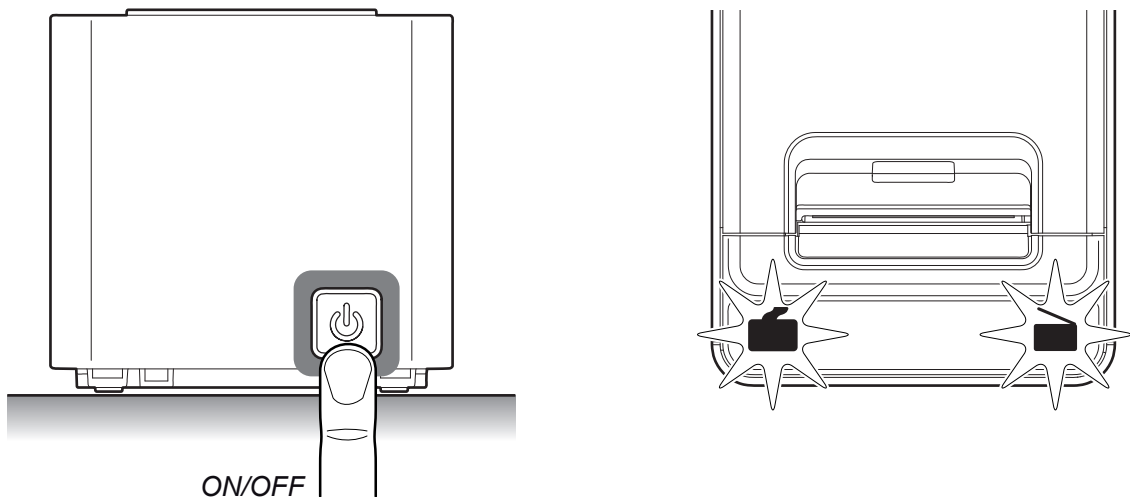

Switch device On pressing key ON/OFF, The indicator lights are switched on and the device is ready.
Switch device Off pressing key ON/OFF.

4.5 Loading the paper roll

To change the paper proceed as follows. At every change of paper, check inside the device to locate and remove any scraps of paper.

1

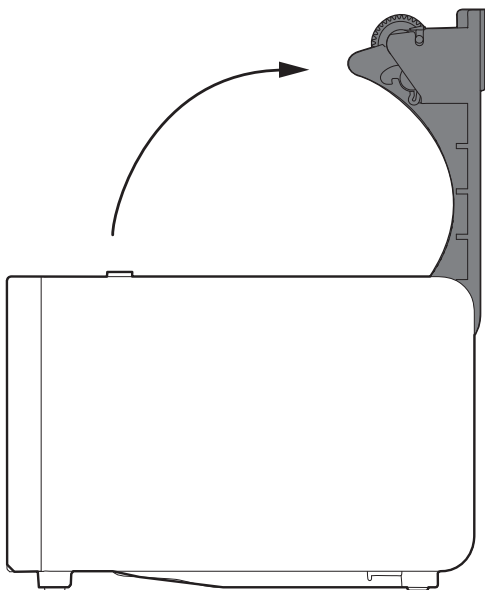

Open the device cover and if necessary, adjust the paper width (see previous paragraphs).

2

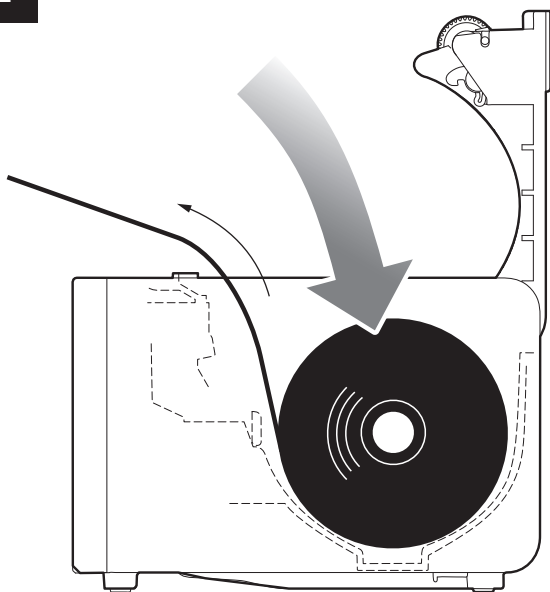

Place the roll in the paper compartment and pull out the paper for a few centimetres.

3

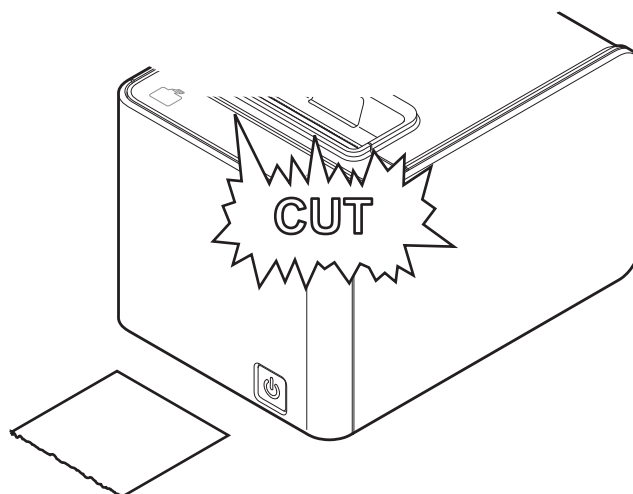
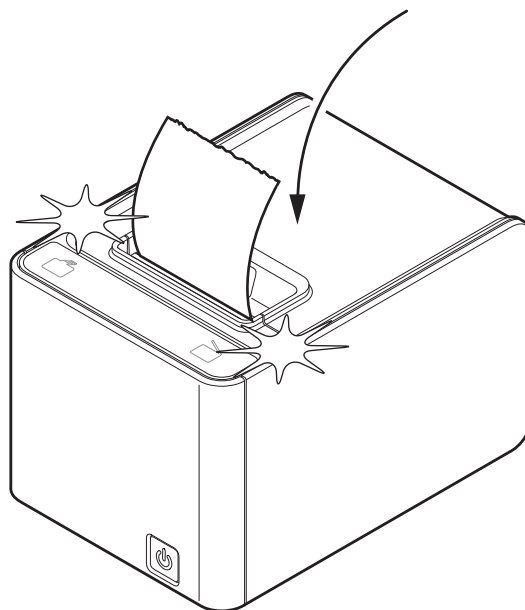

Close the device cover and wait until the paper is loaded and automatically cut off.

4.6 Loading the fanfold

To change the paper proceed as follows. At every change of paper, check inside the device to locate and remove any scraps of paper.

1

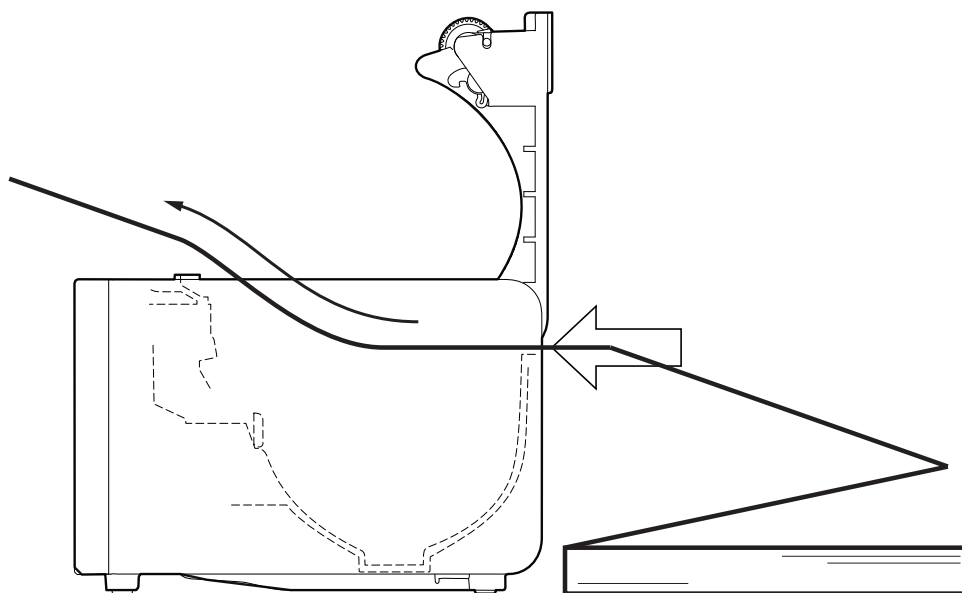

Open the device cover (see par. 4.1) and insert the fanfold through the input slot, located on the back of the device. Pull out the paper for a few centimetres.

2

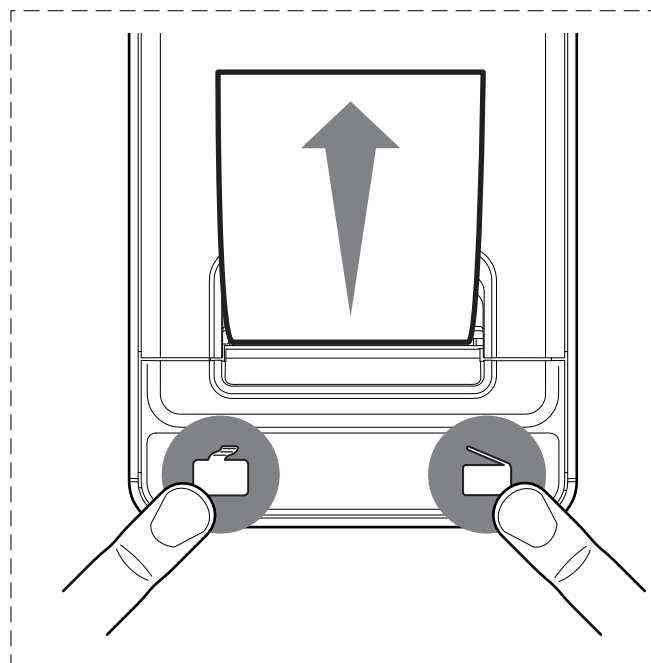
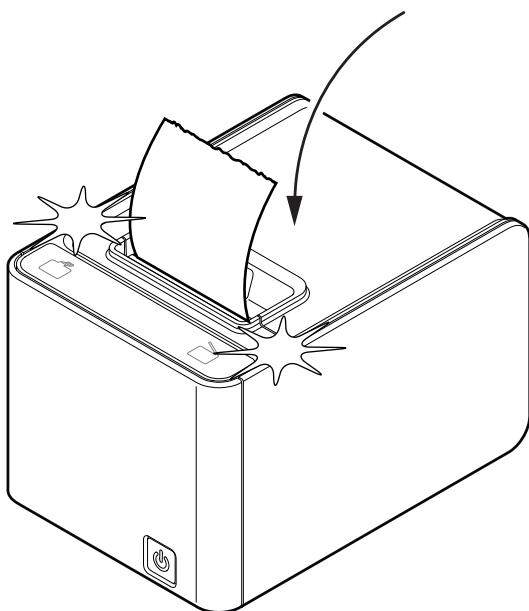

Close the device cover.

If the parameter "Notch Alignment" is enabled Proceed with alignment by pressing both keys

5 CONFIGURATION

5.1 Configuration mode

To enter the configuration mode and print a SETUP report with the operating parameters of the device, proceed as follows.

1

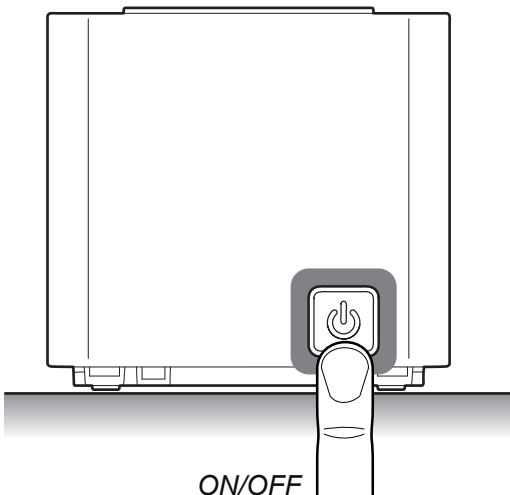

ON/OFF

Turn on the device by pressing the ON/OFF key.

2

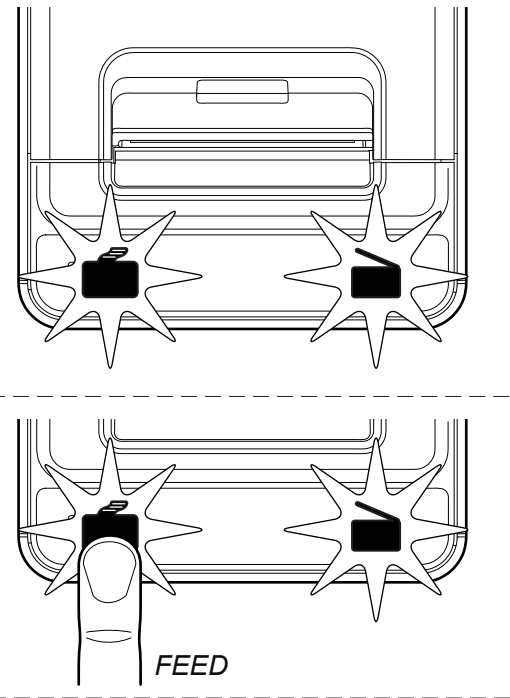

FEED

When the indicator lights come on, press and hold down the FEED key.

3

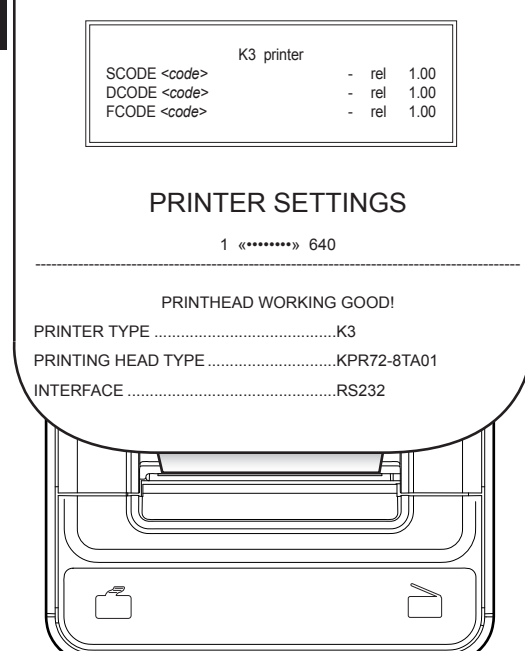

K3 printer
SCODE <code> - rel 1.00
DCODE <code> - rel 1.00
FCODE <code> - rel 1.00

PRINTER SETTINGS

1 «*****» 640

PRINTHEAD WORKING GOOD!

PRINTER TYPEK3
PRINTING HEAD TYPEKPR72-8TA01
INTERFACERS232

The device prints the report with parameters for printer settings.

4

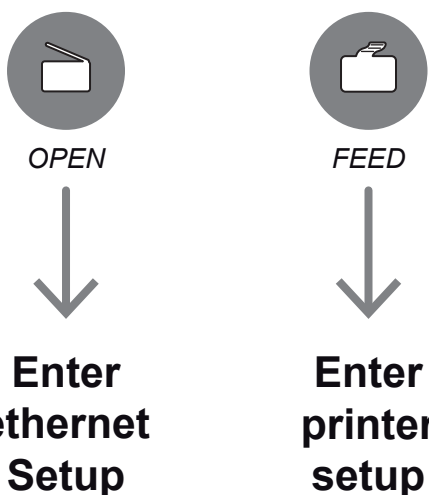

OPEN

FEED

↓

Enter ethernet Setup

Enter printer setup

Press the FEED key to enter the configuration mode or press the OPEN key to print the SETUP report with the Ethernet parameters.

5.2 Setup report

The following figures show the setup reports of the device. The shown values for parameters are sample values; for the list and the description of device and Ethernet parameters see the following paragraphs.

<p><i>DEVICE NAME and FIRMWARE MODULES RELEASE</i></p>	}	<p style="text-align: center;">K3 printer</p> <p>SCODE <code> - rel 1.00 DCODE <code> - rel 1.00 FCODE <code> - rel 1.00</p>
<p><i>PRINTING HEAD STATUS</i></p>	}	<p style="text-align: center;">PRINTER SETTINGS</p> <p style="text-align: center;">1 «*****» 576</p> <hr style="border-top: 1px dashed black;"/> <p style="text-align: center;">PRINthead WORKING GOOD!</p>
<p><i>DEVICE STATUS</i></p>	}	<p>PRINTER TYPEK3 PRINTING HEAD TYPE.....KPR72-8TA01 INTERFACERS232 PROGRAM MEMORY TEST.....OK DYNAMIC RAM TEST.....OK EXTERNAL MEMORY TESTOK CUTTER TEST.....OK HEAD VOLTAGE [V] = 23,37 HEAD TEMPERATURE [°C] = 25 POWER ON COUNTER = 4 PAPER PRINTED [cm] = 40 CUT COUNTER = 1</p>
<p><i>PRINTER PARAMETERS</i></p>	}	<p>Printer Emulation : CUSTOM/POS RS232 Baud Rate : 115200 bps RS232 Data Length..... : 8 bits/chr RS232 Parity : None RS232 Handshaking : Hardware Busy Condition : RxFull USB Mass Storage..... : Disabled USB Address Number : 0 USB Virtual COM..... : Disabled Print Mode : Normal Autofeed : CR Disabled Code Table [num] : 0 Chinese Font : Disabled Chars / inch : A=15 B=20 cpi Speed / Quality..... : Normal Print Width : 72mm[80PaperW] Paper Threshold : 40% Notch/B.Mark Position : Bottom Notch Threshold : 40% Notch Distance [mm] : +15 Total cut : Enabled PaperEnd Buffer Clear : Disabled PrintHead Test PowerOn..... : Disabled Data Logger..... : Disabled Line Space Reduction : Disabled Line Feed Reduction : Disabled Barcode height Reduct..... : Disabled Print Density : 0%</p>
<p><i>KEYS FUNCTIONS</i></p>	}	<p>[FEED] enter Printer setup [OPEN] enter Ethernet Setup [FEED + OPEN] skip Setup</p>

KEYS FUNCTIONS	{	<p>[FEED] enter Printer setup [OPEN] enter Ethernet Setup [FEED + OPEN] skip Setup</p>
ETHERNET PARAMETERS	{	<p>DHCP Client : Disabled FTP Server : Disabled</p> <p>IP Address : 192.168. 0. 1 Subnet Mask : 255.255.240. 0 Default Gateway..... : 192.168. 0. 5</p> <p>MAC Address : 00-0E-E2-02-0B-0D</p> <p>For advanced printer setup please connect to the site http://192.168.0.1</p>

5.3 Device status

The device operating status is indicated in the configuration print-out in which, next to the name of the components displayed, the following information is given:

PRINTER TYPE	<i>device model</i>
PRINTING HEAD TYPE	<i>print head model</i>
INTERFACE	<i>interface present</i>
PROGRAM MEMORY TEST	<i>OK appears if functioning and NOT OK if faulty</i>
DYNAMIC RAM TEST	<i>OK appears if functioning and NOT OK if faulty</i>
EXTERNAL MEMORY TEST	<i>OK appears if functioning and NOT OK if faulty</i>
CUTTER TEST	<i>OK appears if functioning and NOT OK if faulty</i>
HEAD VOLTAGE	<i>voltage of the head</i>
HEAD TEMPERATURE	<i>temperature of the head</i>
POWER ON COUNTER	<i>number of power-ups made</i>
PAPER PRINTED	<i>centimetres of paper printed</i>
CUT COUNTER	<i>number of cuts performed</i>

5.4 Printer parameters

This device allows the configuration of the parameters listed in the following table.

The parameters marked with the symbol ^D are the default values.

Settings remain active even after the device has been turned off and they are stored in non-volatile memory.

PRINTER EMULATION	<i>Available emulations for the device:</i> SVELTA CUSTOM/POS ^D
RS232 BAUD RATE	<i>Communication speed of the serial interface:</i> 115200 ^D 9600 57600 4800 38400 2400 19200 1200 NOTE: Parameter valid only with serial interface.
RS232 DATA LENGTH	<i>Number of bit used for characters encoding:</i> 7 bits/char 8 bits/char ^D NOTE: Parameter valid only with serial interface.
RS232 PARITY	<i>Bit for the parity control of the serial interface:</i> None ^D = parity bit omitted Even = even value for parity bit Odd = odd value for parity bit NOTE: Parameter valid only with serial interface.
RS232 HANDSHAKING	<i>Handshaking:</i> XON/XOFF = software handshaking Hardware ^D = hardware handshaking (CTS/RTS) NOTES: Parameter valid only with serial interface. When the receive buffer is full, if handshaking is set to XON/XOFF, the device sends the XOFF (0x13) on the serial port. When the receive buffer has cleared once again, if handshaking is set to XON/XOFF, the device sends the XON (0x11) on the serial port.
BUSY CONDITION	<i>Activation mode for Busy signal:</i> OffLine/ RXFull = Busy signal is activated when the device is both in OffLine status and the buffer is full RXFull ^D = Busy signal is activated when the buffer is full NOTE: Parameter valid only with serial interface.

USB MASS STORAGE *Sharing mode from Mass Storage:*

Disabled^D = sharing mode disabled
Enabled = sharing mode enabled

USB ADDRESS NUMBER *Numerical address code for the univocal identification of the USB device (in case of more than a USB device connected with the same PC):*

<i>0^D</i>	<i>2</i>	<i>4</i>	<i>6</i>	<i>8</i>
<i>1</i>	<i>3</i>	<i>5</i>	<i>7</i>	<i>9</i>

USB VIRTUAL COM *Setting the USB port as a virtual serial port:*

Disabled^D = Virtual COM disabled
Enabled = Virtual COM enabled

PRINT MODE *Printing mode:*

Normal^D = enables printing in normal writing way
Reverse = enables printing rotated 180 degrees

AUTOFEED *Setting of the Carriage Return character:*

CR disabled^D = Carriage Return disabled
CR enabled = Carriage Return enabled

NOTE: The parameter is printed only with CUSTOM/POS emulation enabled.

CODE TABLE [num] *Identifier number of the character code table to use.*
The numeric value of the identifier is made up with the following two parameters for the setting of two digits for the tens and the units:

Setting the digit for tens:

CODE TABLE [num x 10]	<i>0^D</i>	<i>2</i>	<i>4</i>
	<i>1</i>	<i>3</i>	<i>5</i>

Setting the digit for units:

CODE TABLE [num x 1]	<i>0^D</i>	<i>2</i>	<i>4</i>	<i>6</i>	<i>8</i>
	<i>1</i>	<i>3</i>	<i>5</i>	<i>7</i>	<i>9</i>

NOTE:
See the paragraph 7.6 to learn about the character tables corresponding to the identification numbers set with this parameter.
The character tables set with this parameter are the same set with the command 0x1B 0x74 (refer to the Commands Manual of the device).

CHINESE FONT *Setting of the chinese font:*

Disabled^D = Disables the use of the chinese extended font GB18030-2000
Enabled = Enables the use of the chinese extended font GB18030-2000

NOTE:
When the chinese font is enabled, the selection of the character code table is suspended (par. "CODE TABLE").
When the Chinese fonts is disabled, it returns the character code table previously in use (par. "CODE TABLE").

CHARS / INCH*Font selection:*

A = 11 cpi, B = 15 cpi
A = 15 cpi, B = 20 cpi^D
A = 20 cpi, B = 15 cpi

NOTES:
CPI = Characters Per Inch
The parameter is printed only with CUSTOM/POS emulation enabled.

SPEED / QUALITY*Setting of printing speed and printing quality:*

Normal^D
High Quality
High Speed
Gray scale

PRINT WIDTH*Width of printing area:*

50mm[58 PaperW]
54mm[60 PaperW]
72mm[80 PaperW]^D

PAPER THRESHOLD*Threshold value (in percent) for the recognition of the presence of paper by the paper presence sensor:*

<i>30%</i>	<i>60%</i>	<i>90%</i>
<i>40%^D</i>	<i>70%</i>	
<i>50%</i>	<i>80%</i>	

NOTCH/B.MARK POSITION*Position of the alignment notch and choice of appropriate notch sensor:*

Disabled^D = the notch alignment is not performed
Top = the notch position is detected by the upper sensors (reflection)
Bottom = the notch position is detected by the lower sensor (reflection)
Transparent = the notch is detected by the lower sensor and the upper sensor placed in front of (transparence)

NOTE:
The value "Top" can be enabled only in presence of the system with three top sensors (optional).
If the device is equipped with the optional mobile sensor and the value "Bottom" is enabled, the following happens: the fixed sensor takes care of detecting the paper presence and the mobile sensor takes care of detecting the notch.

NOTCH THRESHOLD*Threshold value (in percent) for the recognition of the presence of notch by the notch sensor:*

<i>30%</i>	<i>60%</i>	<i>90%</i>
<i>40%^D</i>	<i>70%</i>	
<i>50%</i>	<i>80%</i>	

NOTE: If the "Notch/B.Mark position" parameter is disabled, this parameter is not printed.

NOTCH DISTANCE

“Notch Distance” is the minimum distance (in millimetres) between the upper edge of ticket and the notch (see chapter 10).
The numeric value of the distance is made up with the following four parameters for the setting of three digits (two for the integer part of the number, one for the decimal part and of the sign):

Sign setting:

NOTCH DISTANCE SIGN

+^D = positive distance
- = negative distance

Setting the digit for tens:

NOTCH DISTANCE [mm x 10]

0 ^D	2	4	6	8
1	3	5	7	9

Setting the digit for units:

NOTCH DISTANCE [mm x 1]

0 ^D	2	4	6	8
1	3	5	7	9

Setting the digit for decimals:

NOTCH DISTANCE [mm x .1]

0 ^D	2	4	6	8
1	3	5	7	9

NOTES:

For example, to set the notch distance to 15 mm, modify the parameters as follows:

Notch Distance Sign = +
Notch Distance [mm x 10] = 1
Notch Distance [mm x 1] = 5
Notch Distance [mm x .1] = 0

If the “Notch/b.mark position” parameter is disabled, the parameters for the “Notch Distance” are not printed.

TOTAL CUT

Sets the behavior of the cutter when the total cut command 0x1B 0x69 (ESC i) is sent:

Disabled = The total cut command 0x1B 0x69 (ESC i) will be ignored and the device executes a partial cut

Enabled^D = The total cut command 0x1B 0x69 (ESC i) will be executed.

PAPEREND BUFFER CLEAR

Cleaning mode of the data in receive buffer, if the printing is stopped due to lack of paper:

Disabled^D = The data remain in the receive buffer. When the paper runs out, the device keeps the remaining data in the receive buffer and prints the remaining portion of the ticket after that the new paper is loaded.

Enabled = When the paper runs out, all data in the receive buffer are deleted.

PRINTHEAD TEST POWERON

Setting of the performing of the print head test:

Disabled^D = the test is performed only during the printing of the setup report

Enabled = the test is performed at each power on

DATA LOGGER

Setting of the data logger function on the LOG folder on the Flash memory:

*Disabled^D = data logger function disabled
Text = the printed text is stored in .txt file
Graphic = the printed graphic is stored in .bmp file
Text + Graphic = both text and graphic are stored in .txt and .bmp files*

NOTE:

The name of the first text file stored will be 00000001.txt; the name of the first graphic file stored will be 00000001.bmp; the file number is incremented automatically, when there is no more space, the oldest files are deleted.

**LINE SPACE
REDUCTION**

Reduction value of line spacing (vertical distance between the base line of a row and the next one). Recommended to reduce paper consumption.

*Disabled^D
25%
50%
75%*

**LINE FEED
REDUCTION**

Reduction value for the distance of paper feed. Recommended to reduce paper consumption.

*Disabled^D
25%
50%
75%*

**BARCODE HEIGHT
REDUCTION**

Reduction value for the height of the barcode printed. Recommended to reduce paper consumption.

*Disabled^D
25%
50%
75%*

PRINT DENSITY

Adjusting the printing density:

<i>-50%</i>	<i>-12%</i>	<i>+25%</i>
<i>-37%</i>	<i>0^D</i>	<i>+37%</i>
<i>-25%</i>	<i>+12%</i>	<i>+50%</i>

5.5 Ethernet parameters

This device allows the configuration of the parameters listed in the following table. The parameters marked with the symbol ^D are the default values. Settings remain active even after the device has been turned off.

DHCP CLIENT	<i>Setting of the DHCP protocol:</i> <i>Disabled ^D = protocol disabled</i> <i>Enabled = protocol enabled</i>
FTP SERVER	<i>Setting of the FTP server:</i> <i>Disabled ^D = server disabled</i> <i>Enabled = server enabled</i>
IP ADDRESS	<i>IP address of device; this parameter is assigned by the network administrator.</i> <div style="background-color: #f0f0f0; padding: 5px;"><i>NOTE: Press the FEED key to modify the value of the highlighted digit. Pressing OPEN key to move the cursor on the next digit (if the cursor is on the latest digit, proceed to next parameter by pressing the OPEN key).</i></div>
SUBNET MASK	<i>IP address of device; this parameter is assigned by the network administrator.</i> <div style="background-color: #f0f0f0; padding: 5px;"><i>NOTE: Press the FEED key to modify the value of the highlighted digit. Pressing OPEN key to move the cursor on the next digit (if the cursor is on the latest digit, proceed to next parameter by pressing the OPEN key).</i></div>
DEFAULT GATEWAY	<i>This parameter identifies the Gateway IP address used to send applications to the external network.</i> <div style="background-color: #f0f0f0; padding: 5px;"><i>NOTE: Press the FEED key to modify the value of the highlighted digit. Pressing OPEN key to move the cursor on the next digit (if the cursor is on the latest digit, proceed to next parameter by pressing the OPEN key).</i></div>
MAC ADDRESS	<i>This is the number, provided by the constructor, that identifies the device; this number is univocal.</i> <div style="background-color: #f0f0f0; padding: 5px;"><i>NOTE: This parameter can't be modified by set up.</i></div>

ATTENTION:

Any changes to network parameters will interrupt browser connection. If the server not responding you must reconnect to the new IP address set.

5.6 Hexadecimal dump

This function is used for the diagnosis of the characters received from the communications port. Characters are printed as hexadecimal code and the corresponding ASCII code (see below). Each line is preceded by a counter in hexadecimal that indicates the number of bytes received.

During the startup, if you hold down the FEED key, the printer enters the self-test routine and print the setup report. The printer remains in standby until a key is pressed or characters are received through the communication port (Hexadecimal Dump mode). For each character sent, the receipt contain an indication of the hexadecimal and ASCII values (if the characters are underlined, the receive buffer is full). Shown below is an example of a Hexadecimal Dump:

HEXADECIMAL DUMP									
31	32	33	34	35	...	<u>12345</u>	...		
39	30	31	32	33	...	<u>90123</u>	...		
37	38	39	75	69	...	<u>789ui</u>	...		
68	6B	6A	73	64	...	<u>hkjsd</u>	...		
73	64	66	6B	6A	...	<u>sdfkj</u>	...		
66	73	64	66	6B	...	<u>fsdfk</u>	...		
65	69	6F	79	75	...	<u>eioyu</u>	...		
6F	72	69	75	77	...	<u>oriuw</u>	...		
6F	75	77	65	72	...	<u>ouwer</u>	...		
77	65	72	69	6F	...	<u>werio</u>	...		
72	69	6F	75	77	...	<u>riouw</u>	...		
6B	6C	73	64	66	...	<u>kl sdf</u>	...		
64	66	6B	73	64	...	<u>dfksd</u>	...		
73	64	66	6B	6A	...	<u>sdfkj</u>	...		
66	6B	F2	6A	73	...	<u>fk>j</u>	...		
6A	6B	6C	68			<u>jklh</u>			

6 MAINTENANCE

6.1 Autocutter paper jam

1

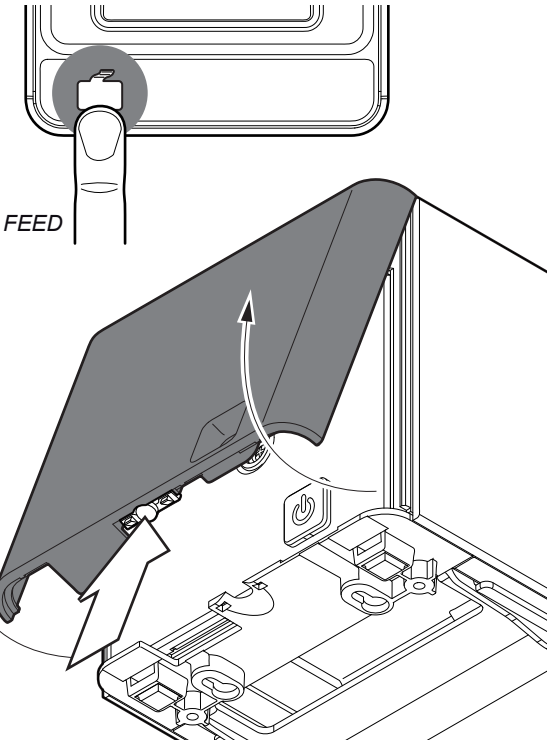

FEED

Press the FEED key to try to unlock the cutter.
If the cutter did not unlock press the release button
and remove the front cover.

2

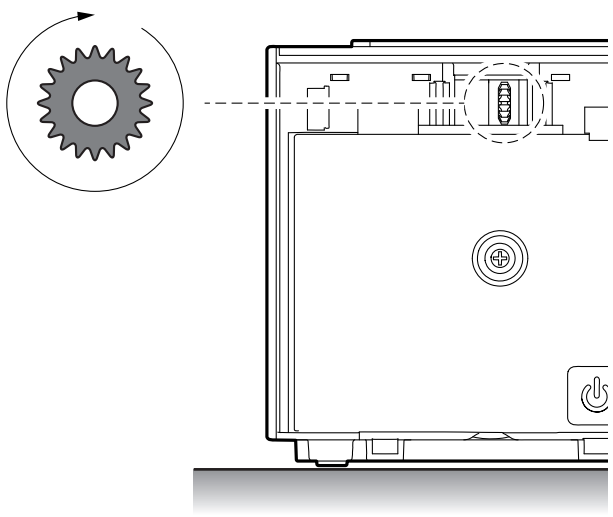

Rotate the gear in one of two directions (approximately
a full turn).

3

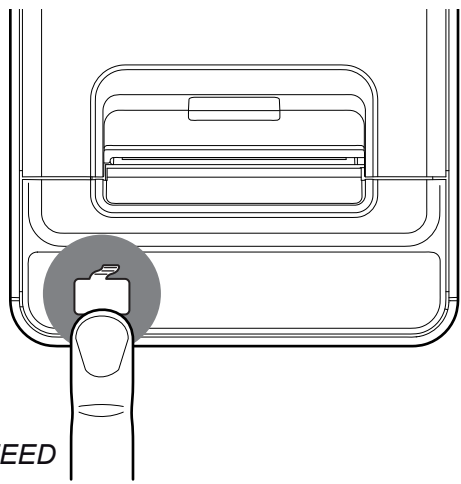

FEED

Press the FEED key.

4

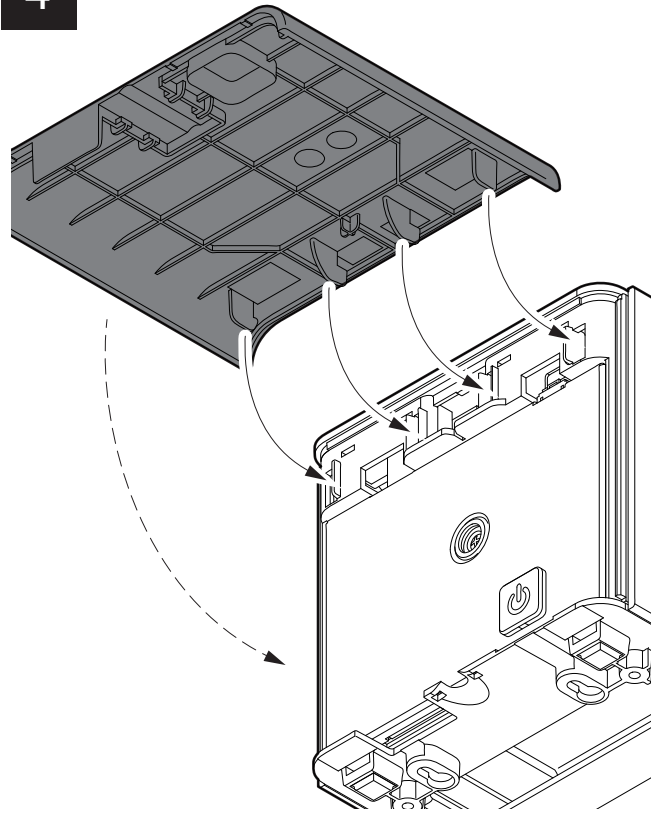

If the problem persists, please
contact the customer service.
Reassemble the cover removed previously.

6.2 Planning of cleaning operations

The regular cleaning of the device keeps the print quality and extends its life. The following table shows the recommended planning for the cleaning operations.

EVERY PAPER CHANGE	
Printhead	Use isopropyl alcohol
Rollers	Use isopropyl alcohol
EVERY 5 PAPER CHANGES	
Cutter	Use compressed air
Paper path	Use compressed air or tweezers
Sensors	Use compressed air
EVERY 6 MONTHS OR AS NEEDED	
Printer case	Use compressed air or a soft cloth

For specific procedures, see the following pages.

NOTE:

If you use the device in dusty environments, you must reduce the intervals between the cleaning operations.

6.3 Cleaning

For periodic cleaning of the device, see the instructions below

Sensors

1

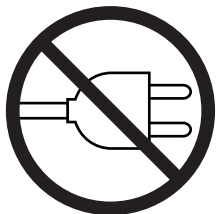

Disconnect the power supply cable and open the device cover (see par. 4.1)

2

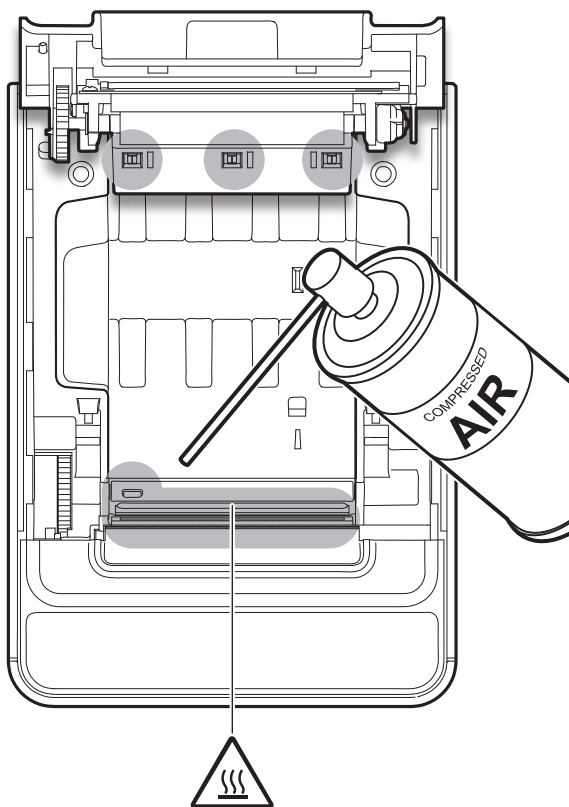

Clean the device sensors by using compressed air.

ATTENTION:

Do not use alcohol, solvents, or hard brushes.
Do not let water or other liquids get inside the machine.

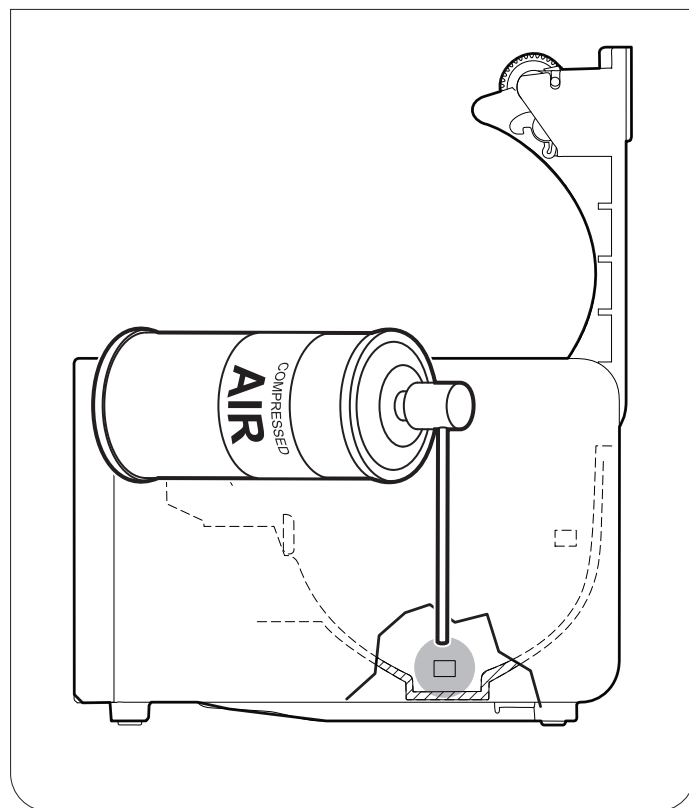

Paper path

1

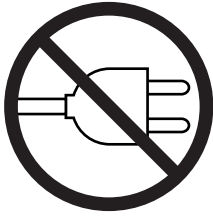

Disconnect the power supply cable and open the device cover (see par. 4.1)

2

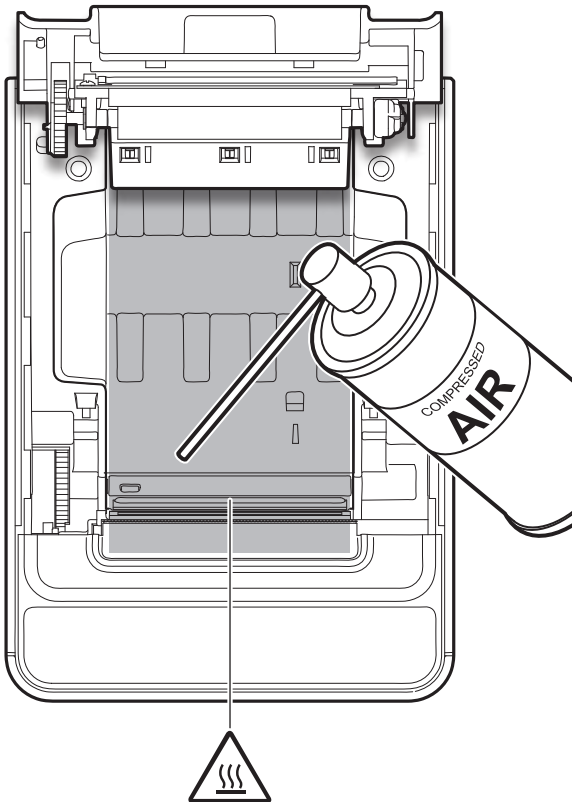

Clean the area involved in the passage of paper by using compressed air.

ATTENTION:

Do not use alcohol, solvents, or hard brushes.
Do not let water or other liquids get inside the machine.



Print head

1

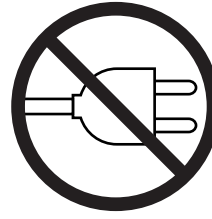

Disconnect the power supply cable and open the device cover (see par. 4.1)

2

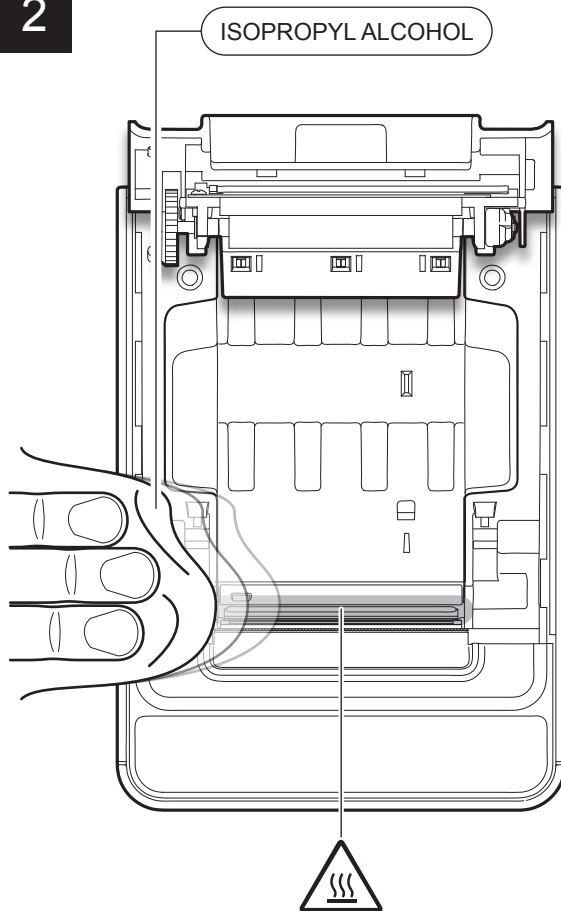

Clean the printing head by using a non-abrasive cloth moistened with isopropyl.

ATTENTION:

Do not use solvents, or hard brushes.
Do not let water or other liquids get inside the machine.



Printing roller

1

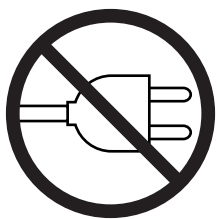

Disconnect the power supply cable and open the device cover (see par. 4.1)

2

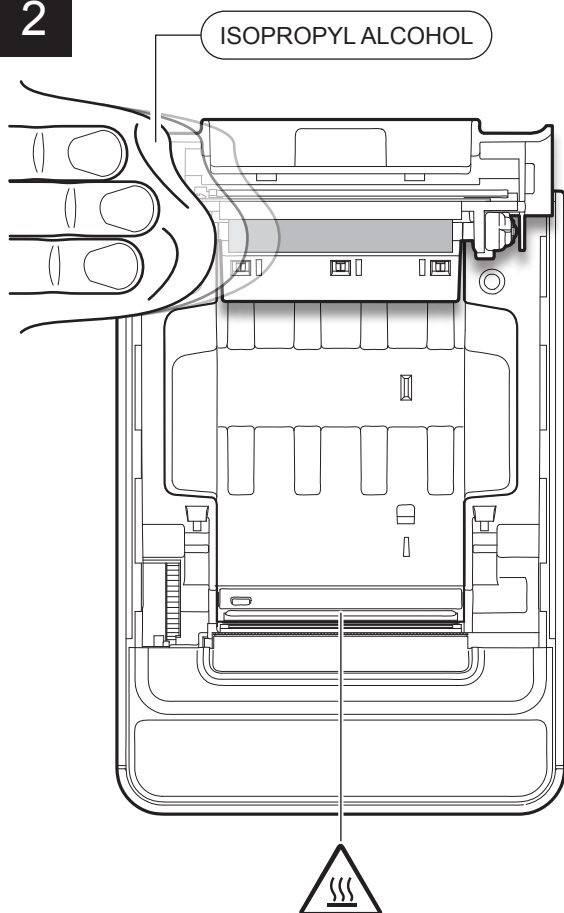

Clean the printing roller by using a non-abrasive cloth moistened with isopropyl.

ATTENTION:

Do not use solvents, or hard brushes.
Do not let water or other liquids get inside the machine.



Case

1

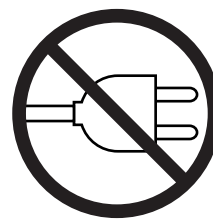

Disconnect the power supply cable

2

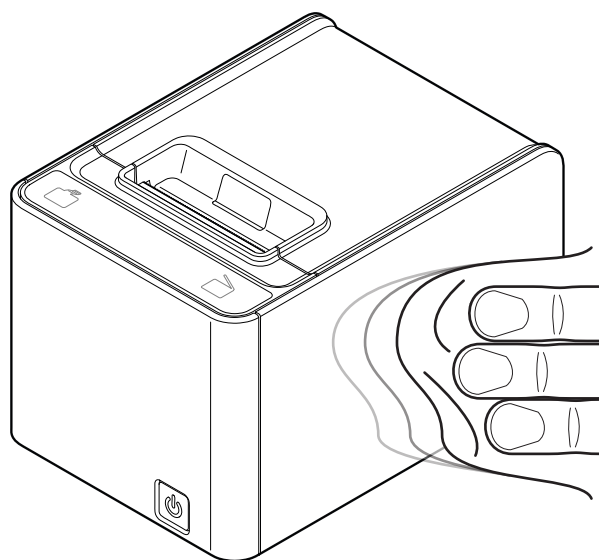

To clean the device, use compressed air or a soft cloth.

ATTENTION:

Do not use alcohol, solvents, or hard brushes.
Do not let water or other liquids get inside the machine.

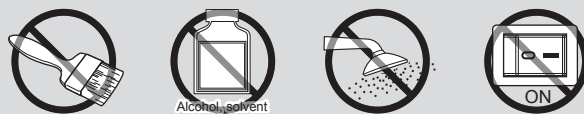

Cutter

1

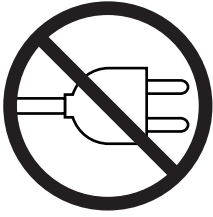

Disconnect the power supply cable and open the device cover (see par. 4.1)

2

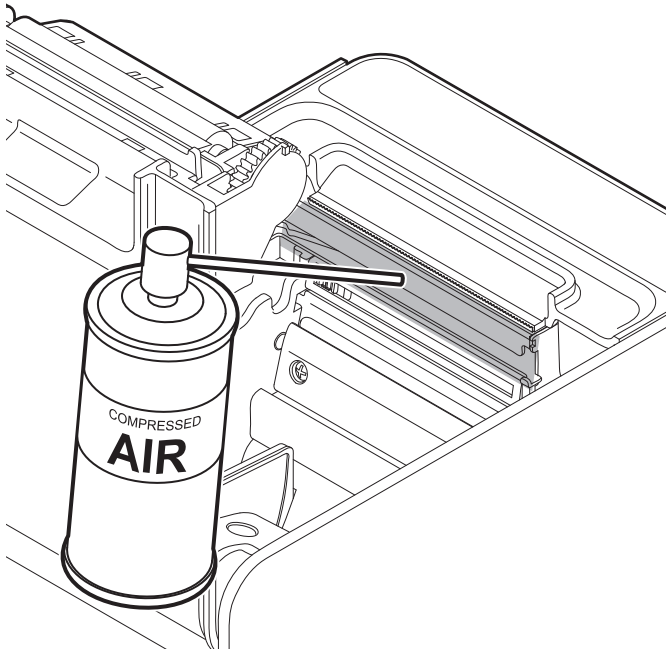

Clean the cutter compartment from the inside using compressed air.

ATTENTION:

Do not use alcohol, solvents, or hard brushes.
Do not let water or other liquids get inside the machine.



3

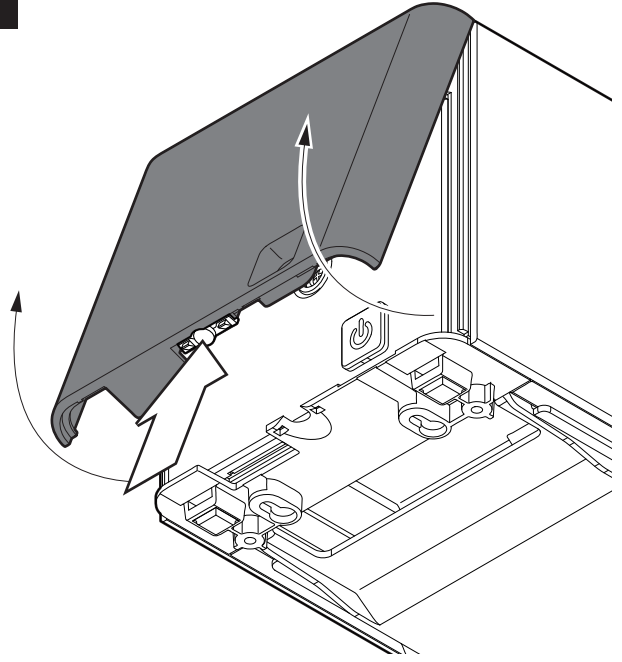

Press the release button and remove the front cover.

4

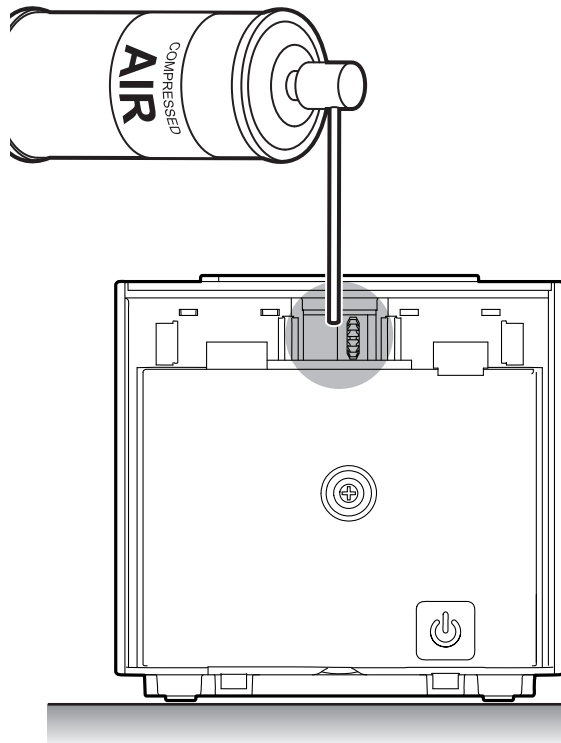

Clean the cutter compartment from the outside using compressed air.

5

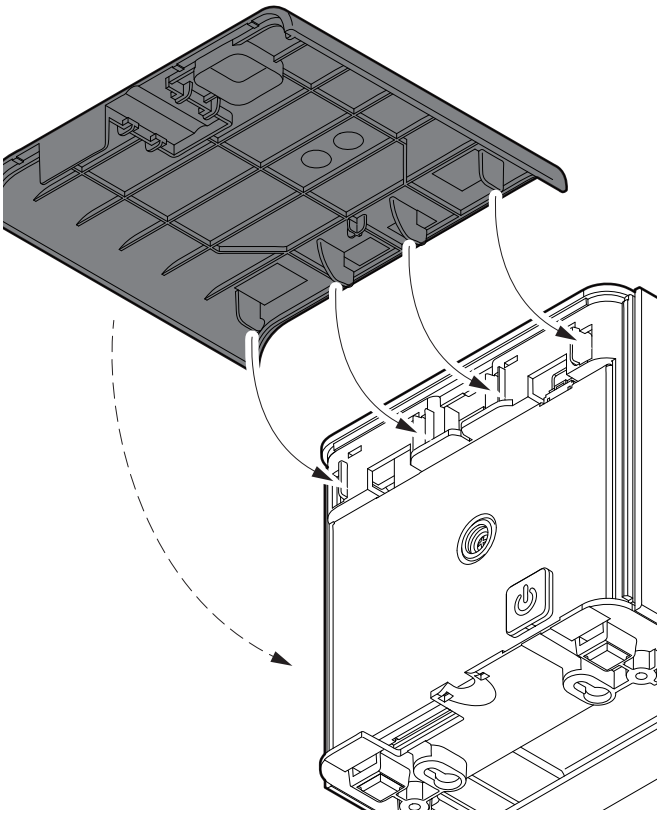

Reassemble the cover removed previously.

6.4 Upgrade firmware

WARNING: During communication between PC/device for the firmware update it is strictly forbidden to disconnect the communication cable or to remove the power supply of the devices not to endanger the proper functioning of the device.

NOTES:

The latest firmware of the device is available in the download area of the web site www.custom.biz

Install on the PC used for device upgrading the UPG-CEPRN software available in the download area of the web site www.custom.biz.

UPDATE VIA SERIAL INTERFACE

Proceed as follows:

1. Write down the product code (14 digits) printed on the product label (see par. 2.3).
2. Go to the web site www.custom.biz and download the appropriate firmware release from the DOWNLOAD area.
3. Print the SETUP report (see chapter 5).
4. Switch off the device.
5. Connect the device to the PC using a serial cable (see paragraph 3.2).
6. Switch on the device.
7. Launch the software UPGCEPRN.
8. Select the update file .PSW location:

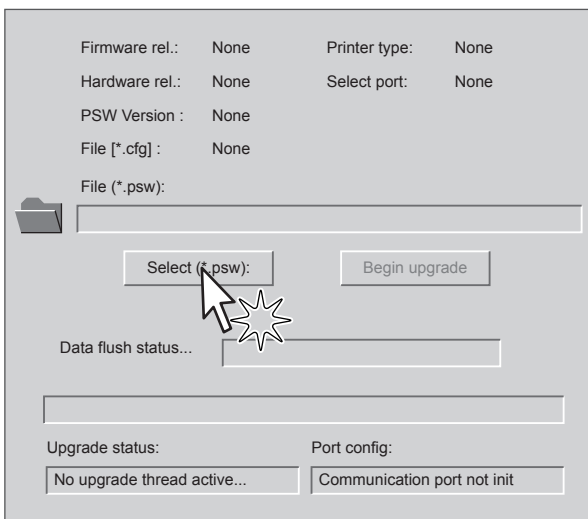

9. Select the serial communication port (ex. COM1):

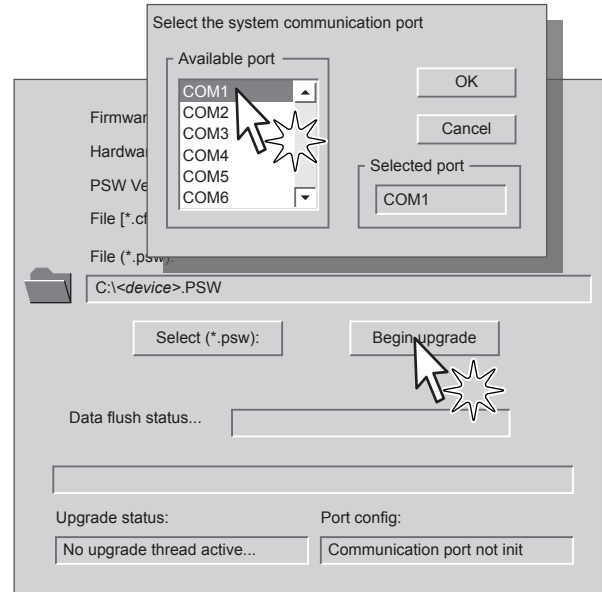

10. Detecting and setting of the parameters necessary for serial communication are performed automatically and then updating begins.
11. After a few minutes a message on the screen warns that the update is completed.

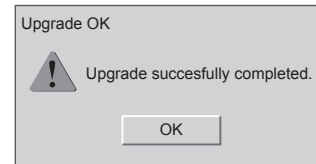

12. Print a new SETUP report to verify the new firmware release (see chapter 5).

UPDATE VIA USB INTERFACE

ATTENTION:

Only during the firmware update, the connection between PC and device must be direct, without the use of wireless HUB.

Only during the firmware update, do not connect or disconnect other USB devices.

NOTE: For communication via USB you must install on PC the device driver available in the download area of the web site www.custom.biz.

Proceed as follows:

1. Write down the product code (14 digits) printed on the product label (see par. 2.3).
2. Go to the web site www.custom.biz and download the appropriate firmware release from the DOWNLOAD area.
3. Print the SETUP report (see chapter 5).
4. Switch off the device.
5. Connect the device to the PC using a USB cable (see paragraph 3.2).
6. Switch on the device.
7. Launch the software UPGCEPRN.
8. Select the update file .PSW location:

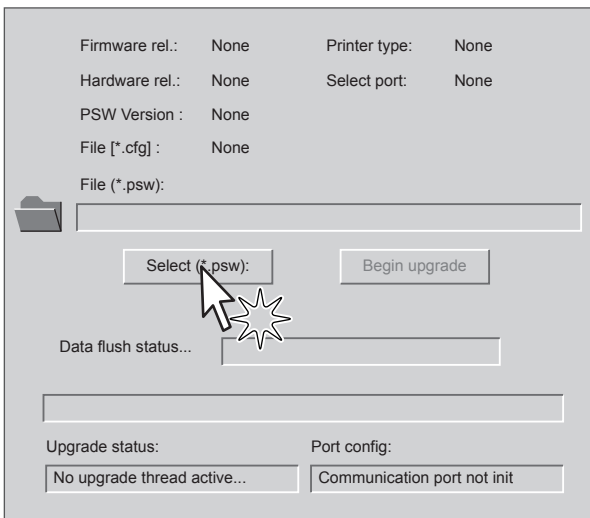

9. Select item USB and then select the USB device among those proposed (ex. device1):

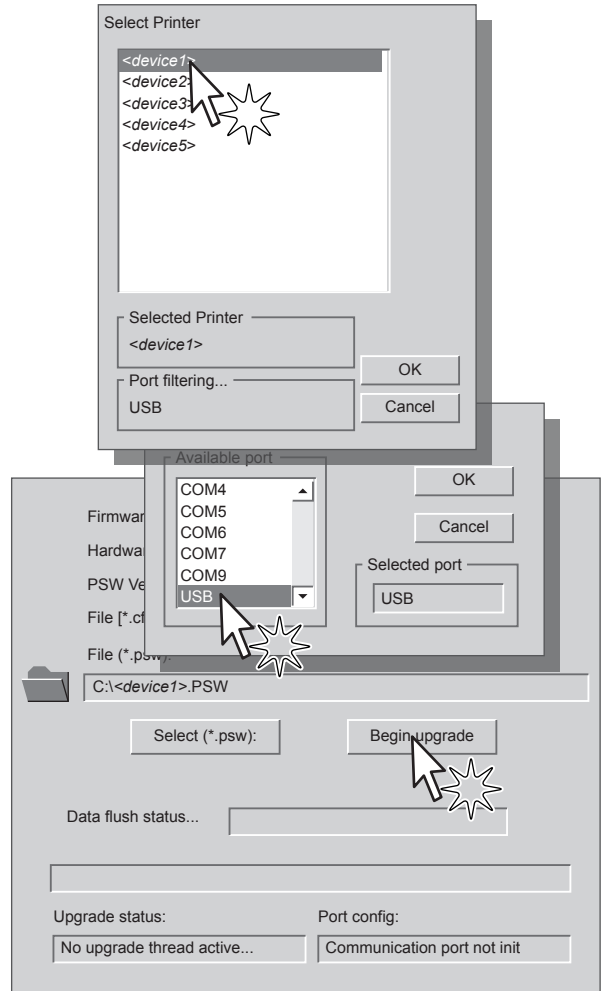

10. After a few minutes a message on the screen warns that the update is completed.

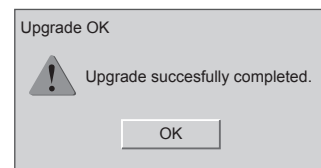

11. Print a new SETUP report to verify the new firmware release (see chapter 5).

7 SPECIFICATION

7.1 Hardware specifications

GENERALS	
Sensors	Head temperature, paper presence, detection of black mark, cover open, low paper, adjustable detection of black mark (optional), detection of black mark on non-thermal side (optional)
Emulations	CUSTOM/POS
Printing driver	Windows XP, VISTA (32/64bit), Windows 7 (32/64bit), Windows 8 (32/64bit), Linux, OPOS, JavaPOS, Android, iOS, Windows Phone 8
INTERFACES	
USB port	12 Mbit/s (USB 2.0 full speed)
RS232 serial port	from 1200 to 115200 bps
ETHERNET port	10 Mbit/s
MEMORIES	
Receive buffer	16 Kbytes
Flash memory	4 Mbytes (+1 Mbyte internal to the micro)
RAM memory	64 Mbytes
Graphic memory	Logos dynamic management (max 1 MB graphic memory)
PRINTER	
Resolution	203 dpi (8 dot/mm)
Printing method	Thermal, fixed head
Head life ⁽¹⁾	200 Km / 200M pulse

Printing width	50, 54, 72 mm
Printing mode	Normal, 90°, 180°, 270°
Printing format	Height/Width from 1 to 8, bold, reverse, underlined, italic
Character fonts	54 character code tables (see par. 7.6) 2 TrueType font ⁽²⁾ Extended chinese GB18030-2000
Printable barcode	UPCA, UPCE, EAN13, EAN8, CODE39, ITF, CODABAR, CODE93, CODE128, CODE32, PDF417, DATAMATRIX, AZTEC, QR CODE
Printing speed ^{(1) (3)}	High Speed = 280 mm/s Normal = 190 mm/s High Quality = 140 mm/s Grey Scale = 120 mm/s

PAPER

Type of paper	Thermal rolls, heat-sensitive side on outside of roll Fanfold
Paper width	80 mm ± 0.5 mm
Paper width (with optional paper width adapter)	58, 60, 80 mm ± 0.5 mm
Paper weight	from 58 g/m ² to 90 g/m ²
Paper thickness	from 63 µm to 85 µm
Recommended types of paper	KANZAN KF50 and KP460 MITSUBISHI PG5075 and TL4000
External roll diameter	max. 100 mm
External roll core diameter	25 mm (+ 1mm)
Core thickness	2 mm (+1 mm)
Paper end	Not attached to roll core
Core type	Cardboard or plastic

CUTTER

Paper cut	Total or partial
Estimated life ⁽¹⁾	1 000 000 cuts

PRINTER ELECTRICAL SPECIFICATIONS

Power supply	24 Vdc \pm 10% (optional external power supply)
Medium consumption ⁽³⁾	1.5 A
Stand-by consumption	0.1 A

ELECTRICAL SPECIFICATIONS POWER SUPPLY cod.963GE020000003

Power supply voltage	from 100 Vac to 240 Vac
Frequency	from 50 Hz to 60 Hz
Current (output)	2.5 A
Power	60 W

ENVIRONMENTAL CONDITIONS

Operating temperature	from 0°C to +50°C
Relative humidity	from 10% Rh to 85% Rh
Storage temperature	from -20 °C to +70 °C
Storage relative humidity	from 10% Rh to 90% Rh

NOTES:

(1) : Respecting the regular schedule of cleaning for the device components.

(2) : "Veramono.ttf" and "Vera.ttf" are installed on device flash disk. It is possible to install additional TrueType fonts (see par.12.8).

(3) : Referred to a standard CUSTOM receipt (L=10cm, Density = 12,5% dots on).

7.2 Character specifications

Character set		3	
Character density	11 cpi	15 cpi	20 cpi
Number of columns	32	44	57
Chars / second	2026	2806	3648
Lines / second	63	63	63
Characters (L x H mm)-Normal	2.25 x 3	1.625 x 3	1.25 x 3

7.3 Device dimensions

Standard model

Length	206 mm
Height	140 mm
Height with cover open	255 mm
Width	148 mm
Weight	1970 g

NOTE:

Dimensions referred to devices without paper roll.
All the dimensions shown in following figures are in millimetres.

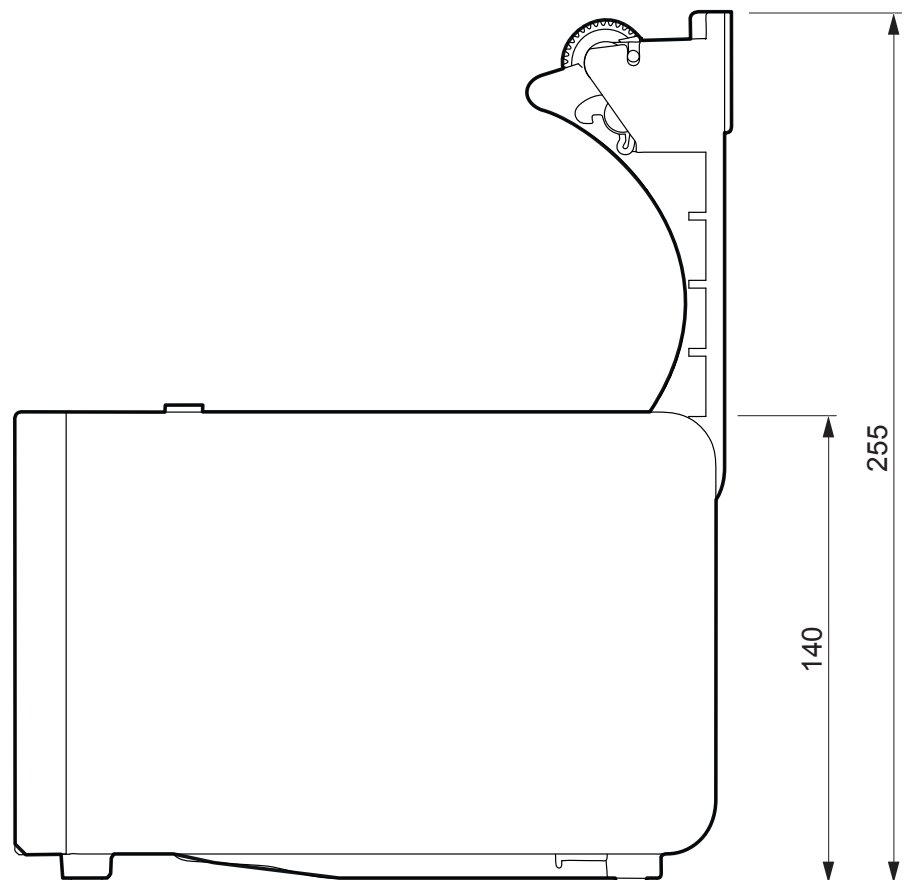
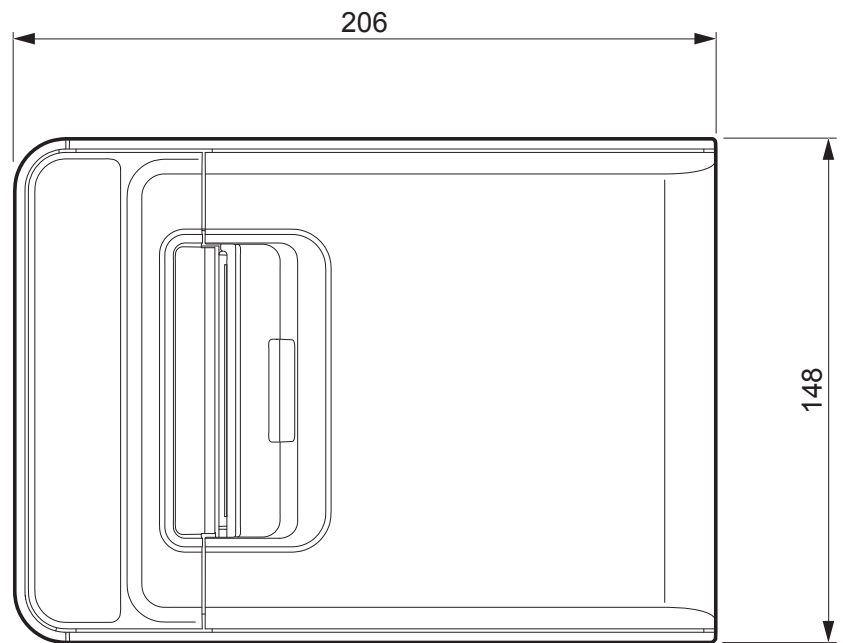

Model with display

Length	230.3 mm
Height	140 mm
Height with cover open	255 mm
Width	148 mm
Weight	2100 g

NOTE:
Dimensions referred to devices without paper roll.
All the dimensions shown in following figures are in millimetres.

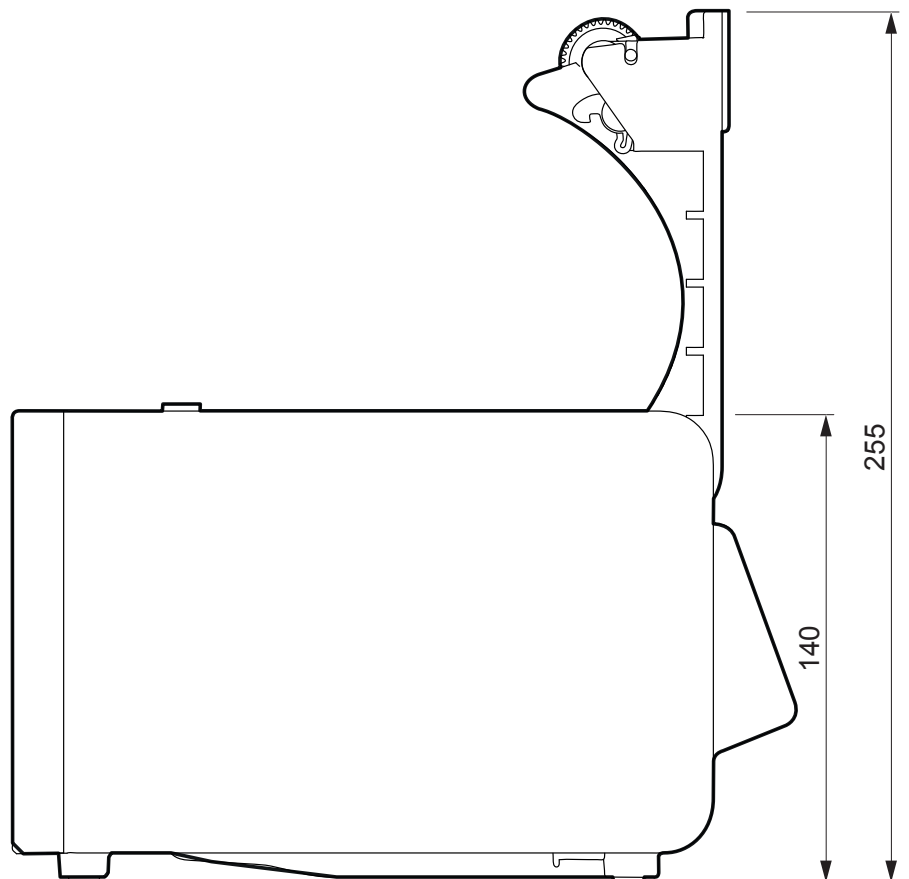
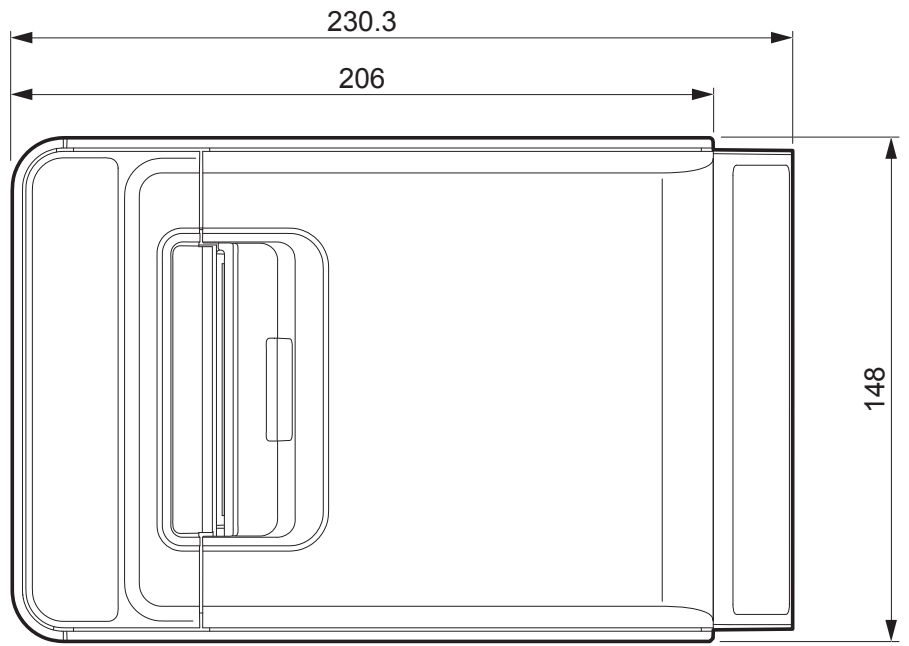

7.4 Power supply dimensions cod. 963GE020000003

Length	127 mm
Height	35.5 mm
Width	56 mm

All the dimensions shown in following figures are in millimetres.

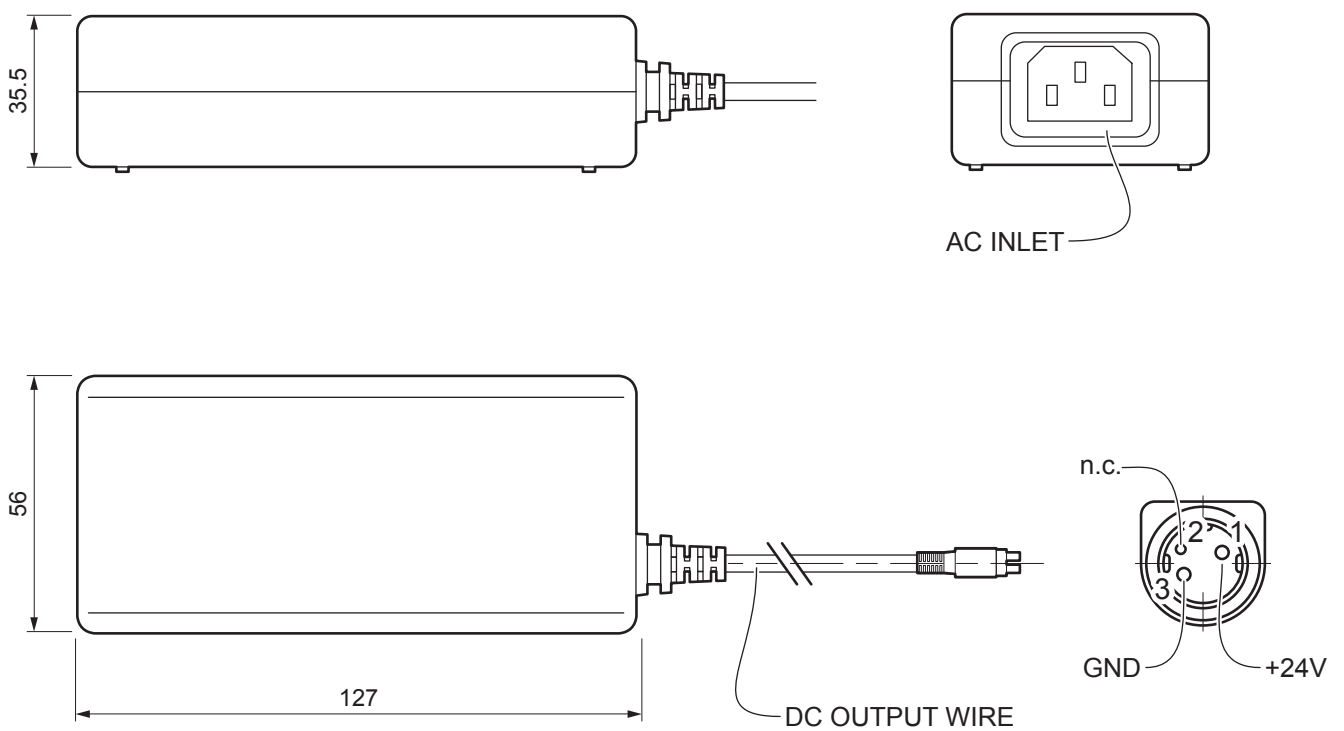

7.5 Paper specification

Paper with black mark for fixed sensor

The following image shows the placement of the black mark on the thermal side of the paper. For more information about the use of paper with black mark see Chapter 10.

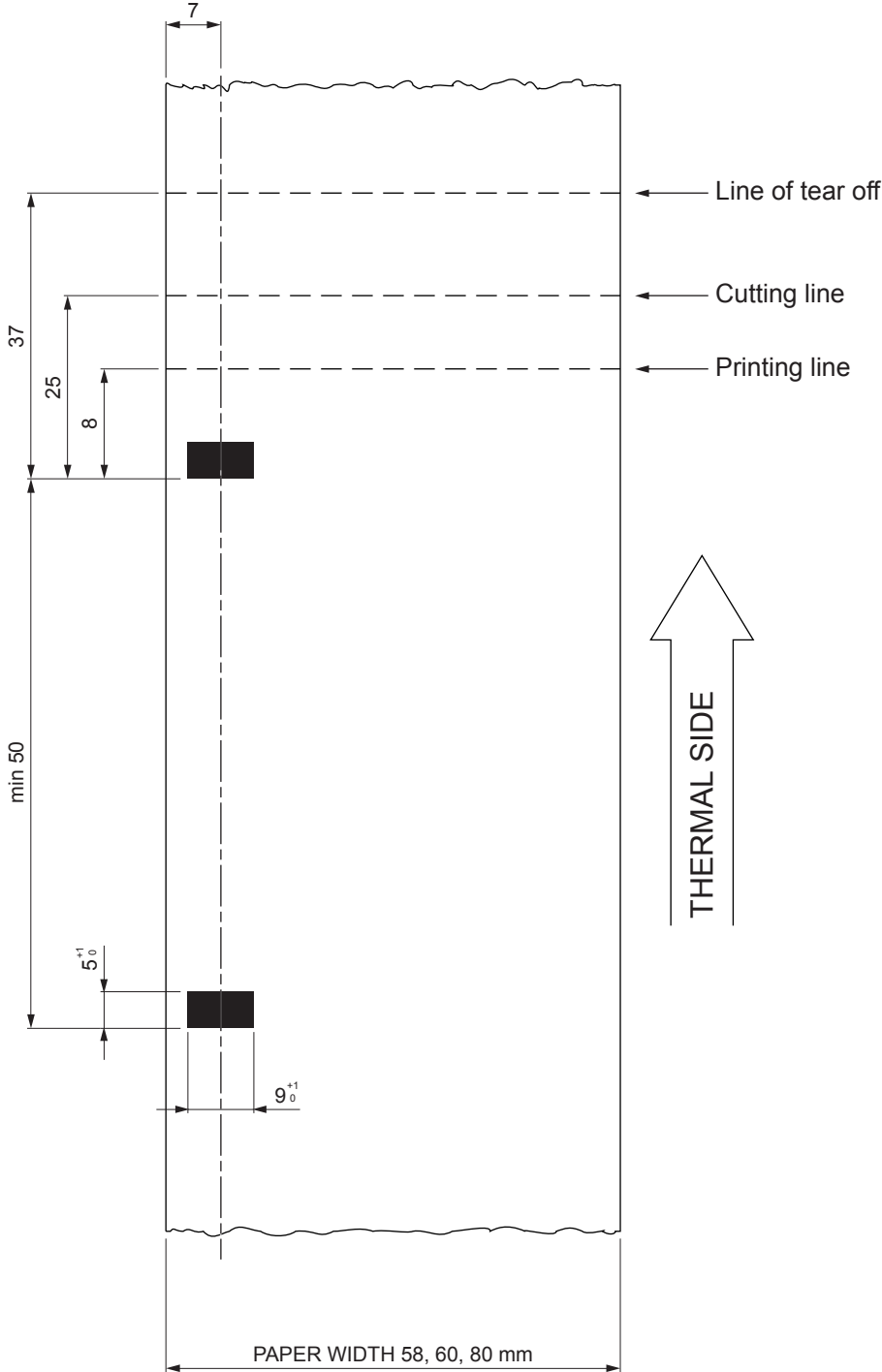

NOTES:
All the dimensions shown in figures are in millimetres.
Paper width 58 mm and 60 mm are available only with adapter paper guide provided as accessory (see chapter 9).

The following image shows the placement of the black mark on the non-thermal side of the paper. The black mark can be placed either in the position P1 or P2 (paper width 58 mm or 60 mm) or even as a P3 (paper width 80 mm). For more information about the use of paper with black mark Chapter 10.

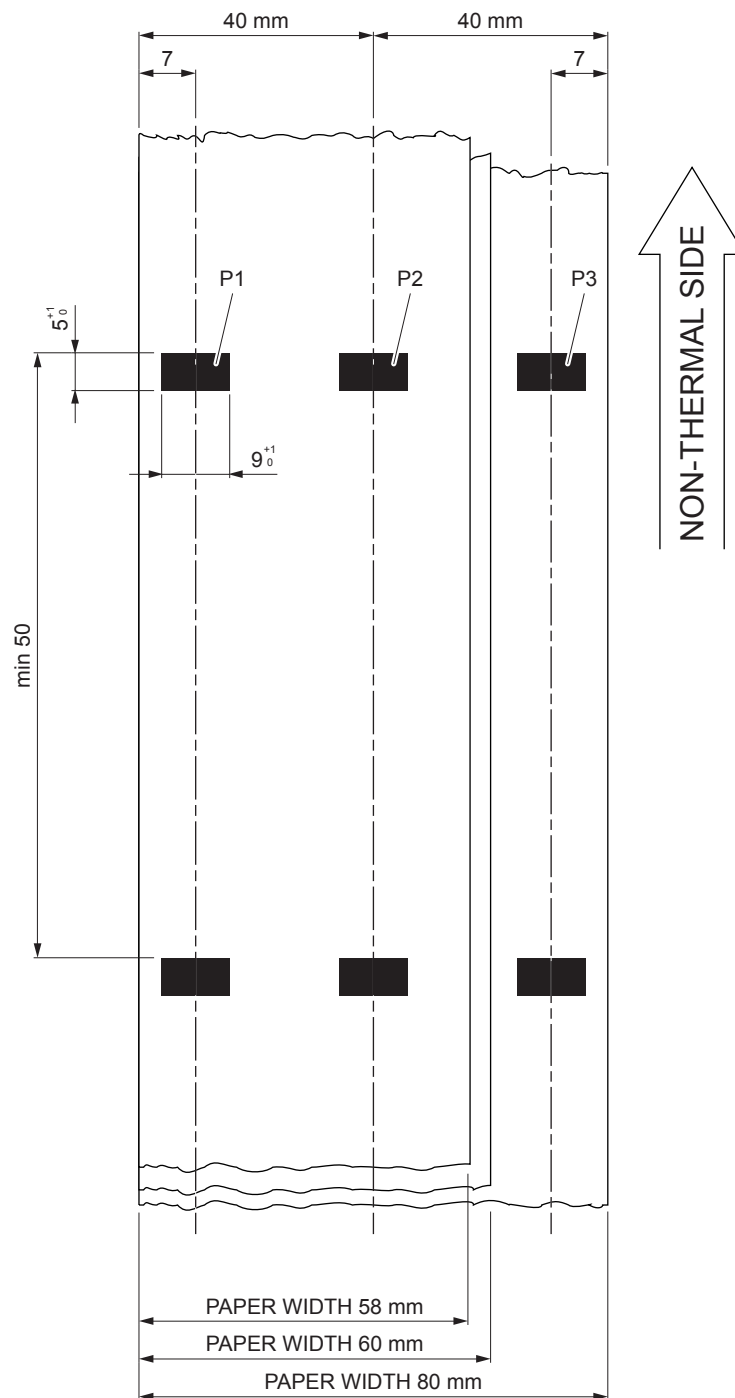

NOTES:

All the dimensions shown in figures are in millimetres.

Paper width 58 mm and 60 mm are available only with adapter paper guide provided as accessory (see chapter 9).

Paper with black mark for mobile sensor

The following image shows the placement of the black mark on the thermal side of the paper. The notch can be placed anywhere on the whole width of the paper.

For more information about the use of paper with black mark see Chapter 10.

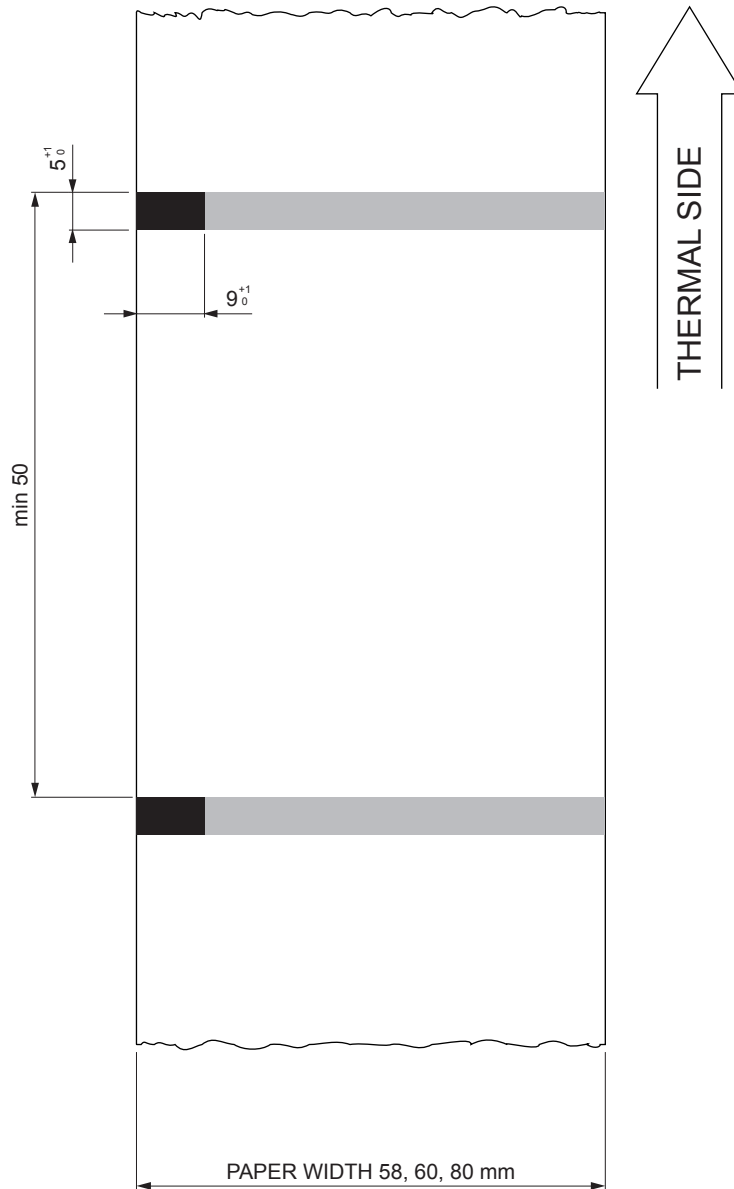

NOTES:

All the dimensions shown in figures are in millimetres.

Paper width 58 mm and 60 mm are available only with adapter paper guide provided as accessory (see chapter 9).

Fanfold paper with hole

The following image shows the placement of the hole on the paper by referring to the thermal side.
To manage tickets with hole, set the parameter "Notch / B.Mark position" to "Transparence" (see par. 5.4).
For more information about the use of paper with hole see Chapter 10.

All the dimensions shown in following figures are in millimetres.

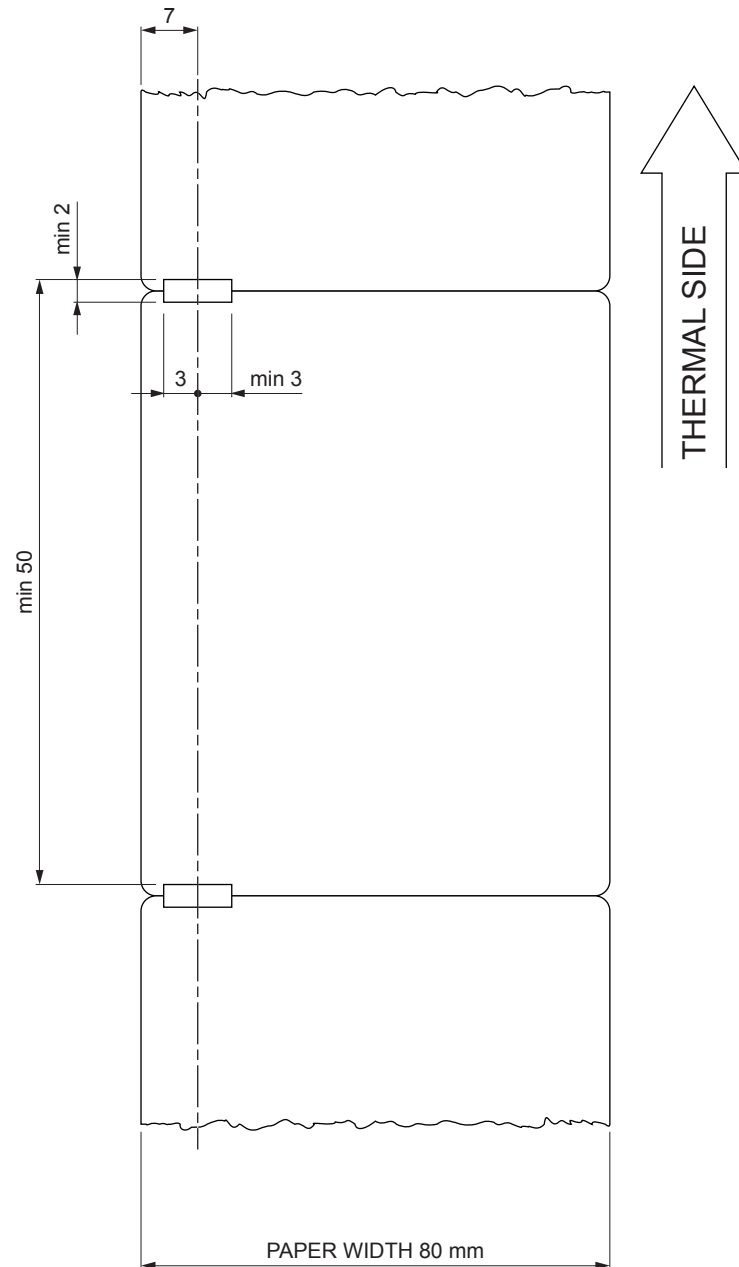

7.6 Character sets in CUSTOM/POS emulation

The printer has 3 internal fonts with a width of 11, 15, 20 cpi, which can be associated with one of the coding tables stored on the device.

To know the coding tables actually stored on the device, print the font test (see par.2.4).

The selection of the font and the encoding table is done via command (see the commands manual of the device) or through the Setup procedure by properly setting the parameter “Chars / Inch”, “Code Table” and “Chinese Font” (see par. 5.4).

The following is the complete list of coding tables that can be installed on the device.

<CodeTable>	Character Tables	
0	PC437 - U.S.A., Standard Europe	
1	Katakana	
2	PC850 - Multilingual	
3	PC860 - Portuguese	
4	PC863 - Canadian/French	
5	PC865 - Nordic	
11	PC851 - Greek	on request
12	PC853 - Turkish	on request
13	PC857 - Turkish	
14	PC737 - Greek	
15	ISO8859-7 - Greek	on request
16	WPC1252	
17	PC866 - Cyrillic 2	
18	PC852 - Latin 2	
19	PC858 for Euro symbol at position 213	
20	KU42 - Thai	
21	TIS11 - Thai	on request
26	TIS18 - Thai	on request
30	TCVN_3 - Vientamese	on request
31	TCVN_3 - Vientamese	on request
32	PC720 - Arabic	on request

<CodeTable>	Character Tables	
33	WPC775 - Baltic Rim	on request
34	PC855 - Cyrillic	
35	PC861 - Icelandic	on request
36	PC862 - Hebrew	
37	PC864 - Arabic	
38	PC869 - Greek	on request
39	ISO8859-2 - Latin 2	on request
40	ISO8859-15 - Latin 9	on request
41	PC1098 - Farci	
42	PC1118 - Lithuanian	on request
43	PC1119 - Lithuanian	on request
44	PC1125 - Ukranian	
45	WPC1250 - Latin 2	
46	WPC1251 - Cyrillic	
47	WPC1253 - Greek	
48	WPC1254 - Turkish	
49	WPC1255 - Hebrew	
50	WPC1256 - Arabic	
51	WPC1257 - Baltic Rim	
52	WPC1258 - Vientamese	
53	KZ1048 - Kazakhstan	
255	Space page	

7.7 True Type fonts

In CUSTOM/POS emulation, it is possible to use TrueType fonts. To be used, a TrueType font must be monospace type (every character of the font must have the same dimension). The check is made by the device when the font is selected.

TrueType fonts will be automatically scaled by the device in order to obtain the same available width for the embedded fonts (11, 15 and 20 cpi).

The quality of TrueType fonts and the correct positioning into the printable area will result from the font producers and the font implementation.

For the correct printing of the code tables, it is necessary that the selected TrueType font contains all the characters in the tables. Otherwise, the '□' symbol will be printed instead the missing character. All commands for printing configuration are usable both with TrueType fonts and with embedded fonts. It is possible to address the TrueType font respects the UNICODE™ standard (see www.unicode.org), by using UTF-8 or UTF-16 encoding.

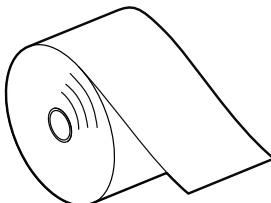
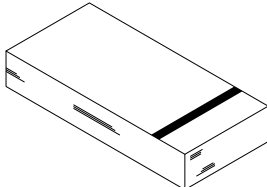

8 CONSUMABLES

The following table shows the list of available consumables for device:

DESCRIPTION	CODE
<p>THERMAL PAPER ROLL</p> <p>weight = 165 g/m² width = 80 mm Ø external = 180 mm Ø core = 25 mm</p>	<p>67300000000385</p> 
<p>FANFOLD</p> <p>weight = 255 g/m² dimensions = 155 mm x 65 mm</p>	<p>67A00000000305</p> 

9 ACCESSORIES

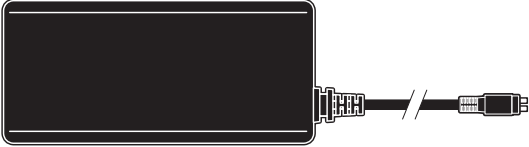
The following table shows the list of available accessories for device:

DESCRIPTION	CODE
POWER SUPPLY (for technical specifications, see the paragraph 7.1)	963GE020000003 
PAPER WIDTH ADAPTER for 58 mm and 60 mm paper width	21400000000193 

10 ALIGNMENT

Device is provided with sensors for the use of alignment notch in order to handle:

- roll of tickets with pre-printed fields and a fixed length;
- FanFold of tickets with pre-printed fields and a fixed length.

The alignment notch may be formed by

- black mark printed on paper (see par.7.5);
- hole between two tickets (see par.7.5);

All alignment sensors are “reflection” sensors: this kind of sensor emits a band of light and detects the quantity of light reflected to it. The presence of the notch is therefore detected by the amount of light that returns to the sensor, considering that the light is reflected by the white paper and absorbed by the black mark.

To use tickets with holes, it is possible to use the same sensors as “transparence” sensors, coupled two by two: a beam of light is emitted by the transmitter sensor and the quantity of light which reaches the opposite receiver sensor is detected. The presence of the hole is detected evaluating the amount of light that arrives to the opposite sensor, considering that the paper doesn't allow the beam of light to reach the receiver, whereas a hole lets the light to reach the receiver.

The following paragraphs show how to correctly set the configuration parameters of device in order to assure the alignment.

10.1 Enable alignment

Device is provided with one, two or three sensors for alignment, placed as follows:

- one fixed sensor on the lower flat of device
- one mobile sensor (optional) on the lower flat of device
- a system with three sensors on the upper flat of device.

To guarantee the alignment, it is necessary to correctly choose the sensor to use for the notch detection depending on the type of notch and its location on the ticket.

To do this, you must enable the parameter “Notch/B.Mark Position” during the Setup procedure (see chapter 5) and set the correct value of this parameter as described in the following table.

SENSOR USED (see following figures)	VALUE OF THE “NOTCH/B.MARK POSITION” PARAMETER	USING MODE OF SENSORS	NOTCH TYPE
-	Disabled	-	Alignment disabled
1	Bottom	Reflection	Black mark printed on the non-thermal side of paper
2	Top	Reflection	Black mark printed on the thermal side of paper
1 + 2	Transparence	Transparence	Hole between tickets

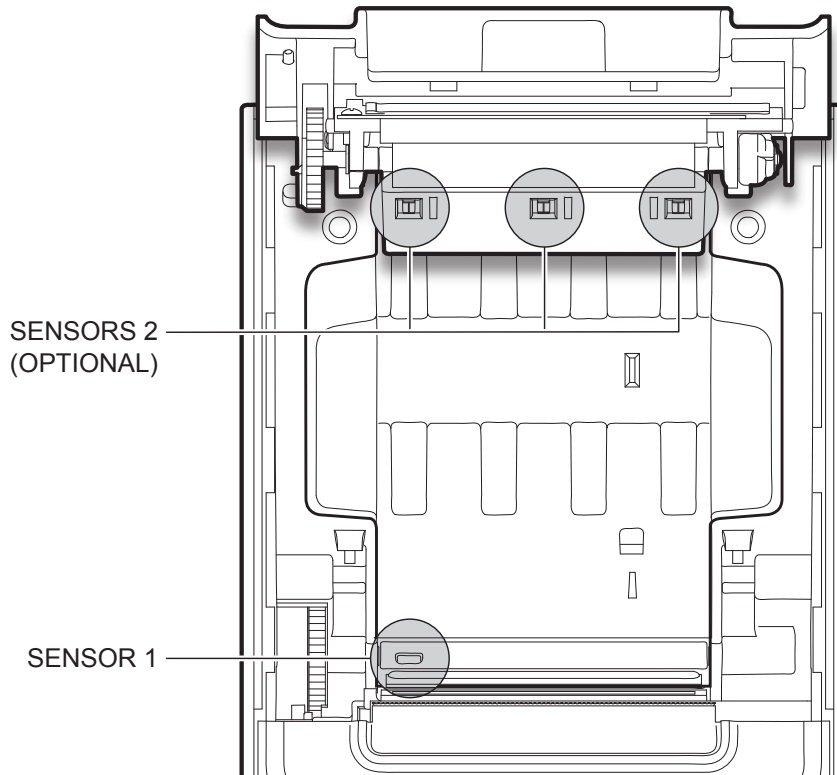

The following figures show the usable format of paper and the corresponding sensors used for alignment:

Paper with black mark on the thermal side

In the standard model the detection of black mark and paper presence is performed by the fixed sensor.

In the model with adjustable sensor (optional) detecting the presence of paper is executed by the fixed sensor while the black mark detection is performed by the mobile sensor.

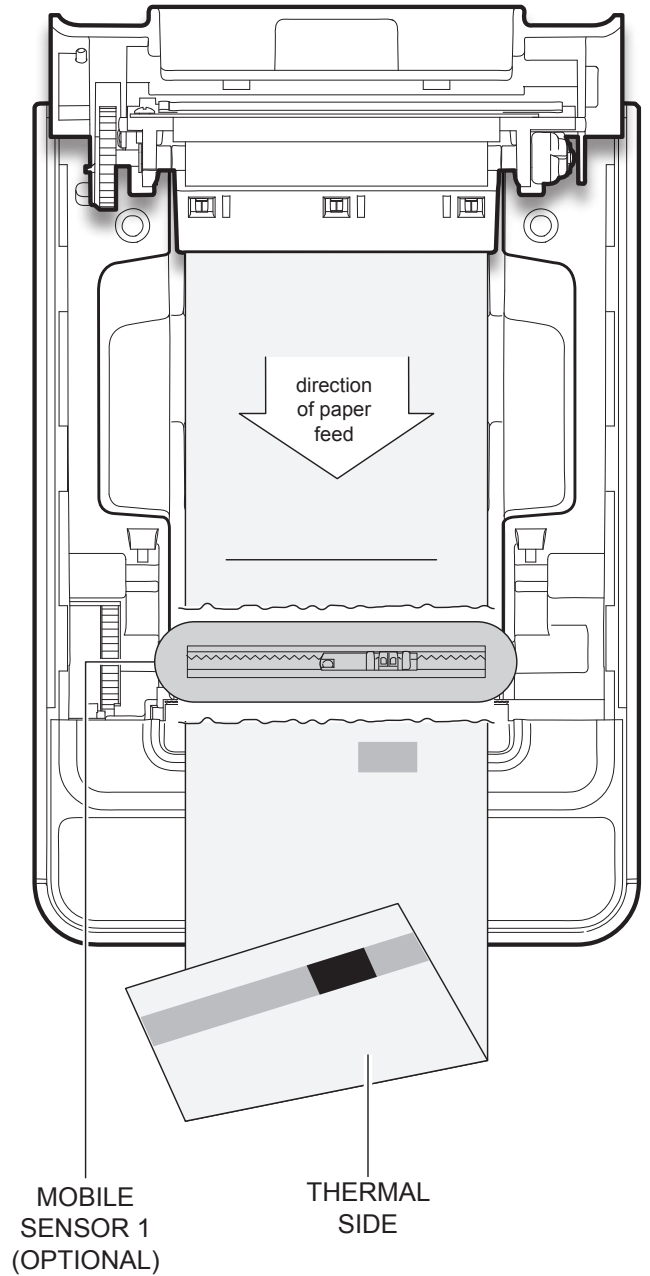
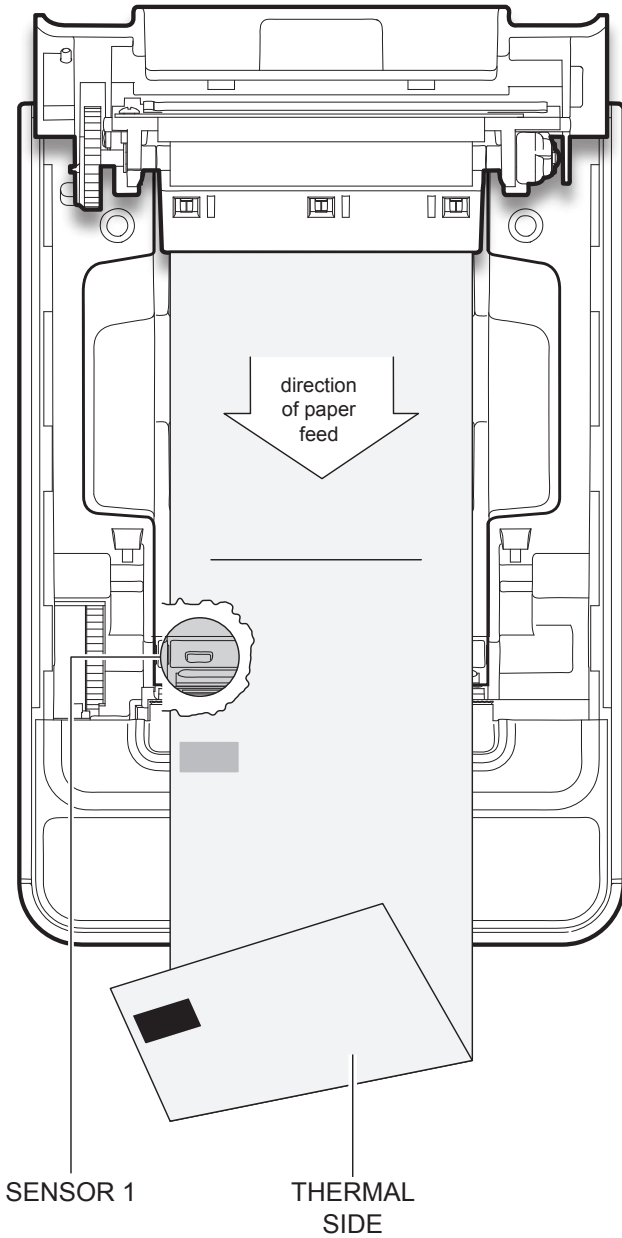

Paper with black mark on the non-thermal

The black mark can be placed in one of three zones shown. This configuration requires the system with three sensors (optional).

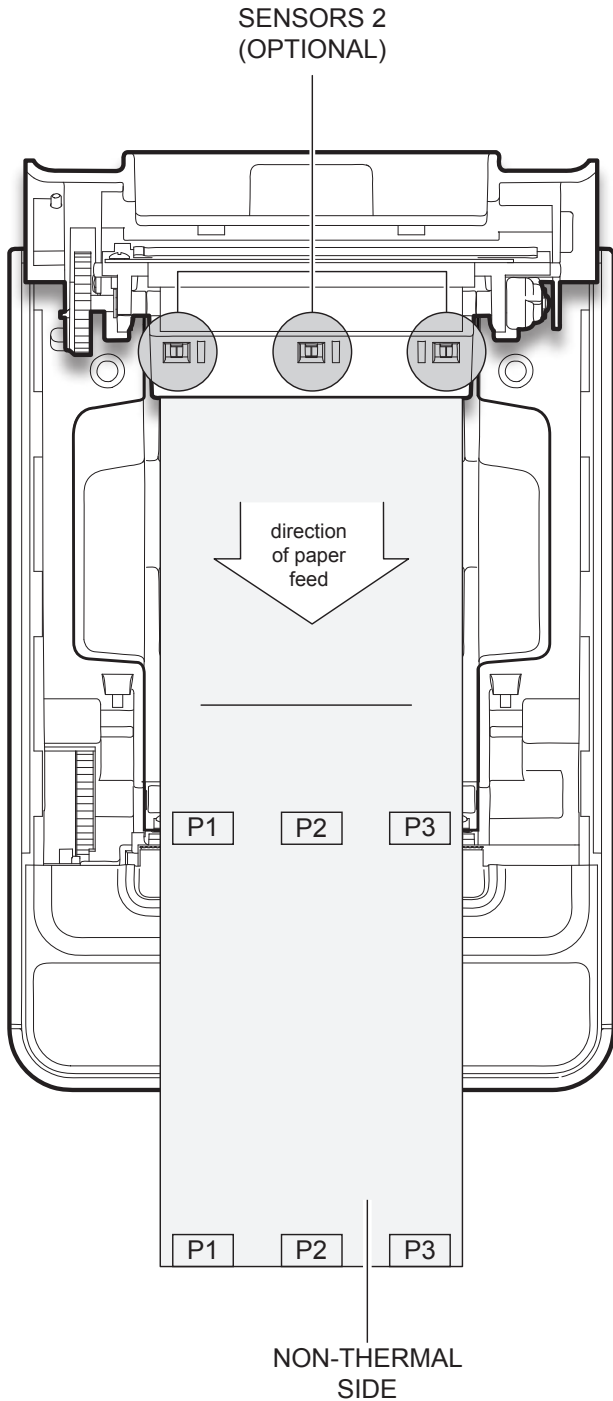

Tickets with hole

This configuration requires the system with three sensors (optional).

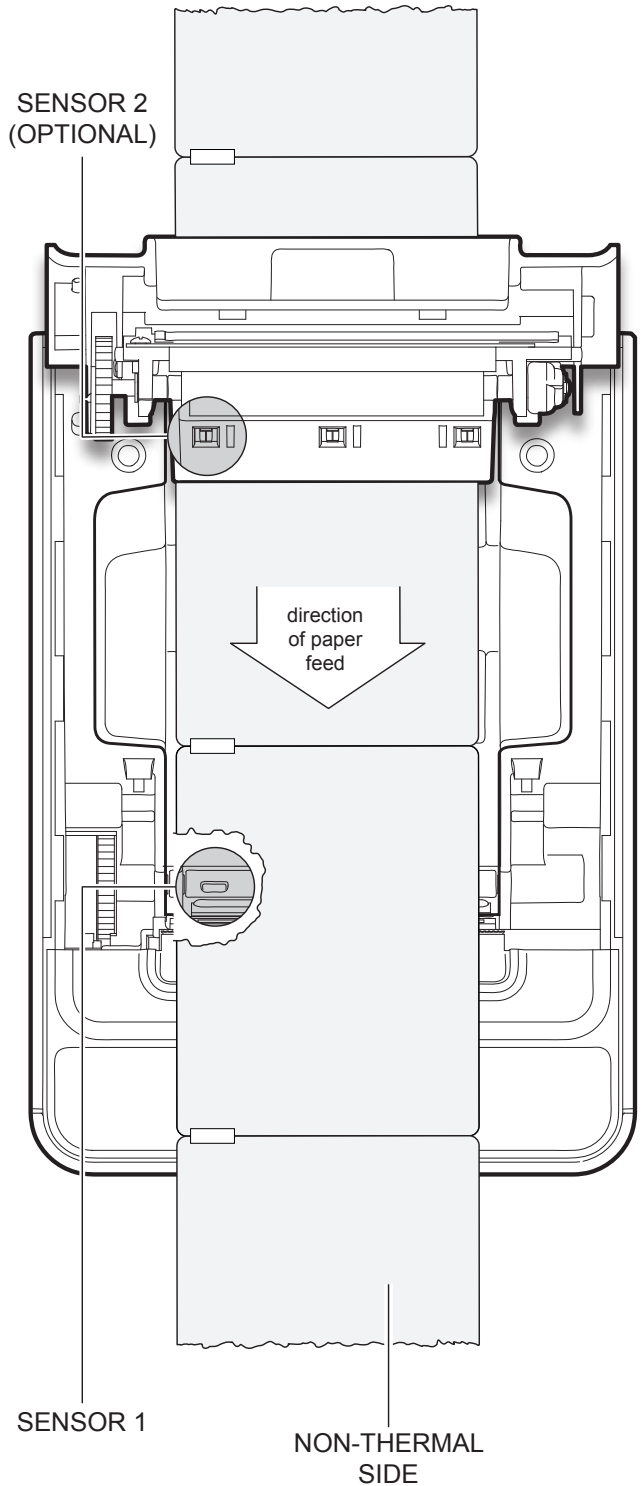

10.2 Calibration

The sensor calibration occurs automatically and consists in adjusting the quantity of light emitted to match the degree of whiteness of the paper used and the degree of black of the mark printed on paper.

The device automatically performs the self-calibration during the Setup procedure only if the “Notch/B.Mark Position” parameter is set to a value other than “Disabled” (see chapter 5).

When self-calibration starts, the device performs some paper feeds and then it prints the calibration result and the value of the PWM duty-cycle of the alignment sensor driver so that it can be perform an optimal notch detection:

Autosetting Notch : OK
PWM Duty Cycle : 85.3%

The “Autosetting Notch” parameter indicates the result of the self-calibration procedure; OK will appear if it has been successful, NOT OK will appear if the procedure has failed.

After the printing of the procedure result, the device offers the execution of the function of paper characterization “Characterize Paper” and the change of the “Notch/B.Mark Threshold” parameter which represents the detection threshold of the notch. Choosing the “Yes” value for the “Characterize Paper” parameter, the device prints a graphic representation (see following figures) of the outgoing voltage of the alignment sensor (expressed as a percentage) and the “Notch/B.Mark Threshold” value. This graphic representation is useful to set the most suitable value to assign to the “Notch/B.Mark Threshold” parameter and then to better identify the optimal threshold value which takes into account the variations of the signal and the small oscillations around zero.

The following figure shows an example of paper with the non-thermal paper printed with black marks: the outgoing voltage is constant while passing the white paper between two notches and presents a peak at each black mark. In this case, the optimal value for the “Notch/B.Mark Threshold” parameter is placed about half of the peak.

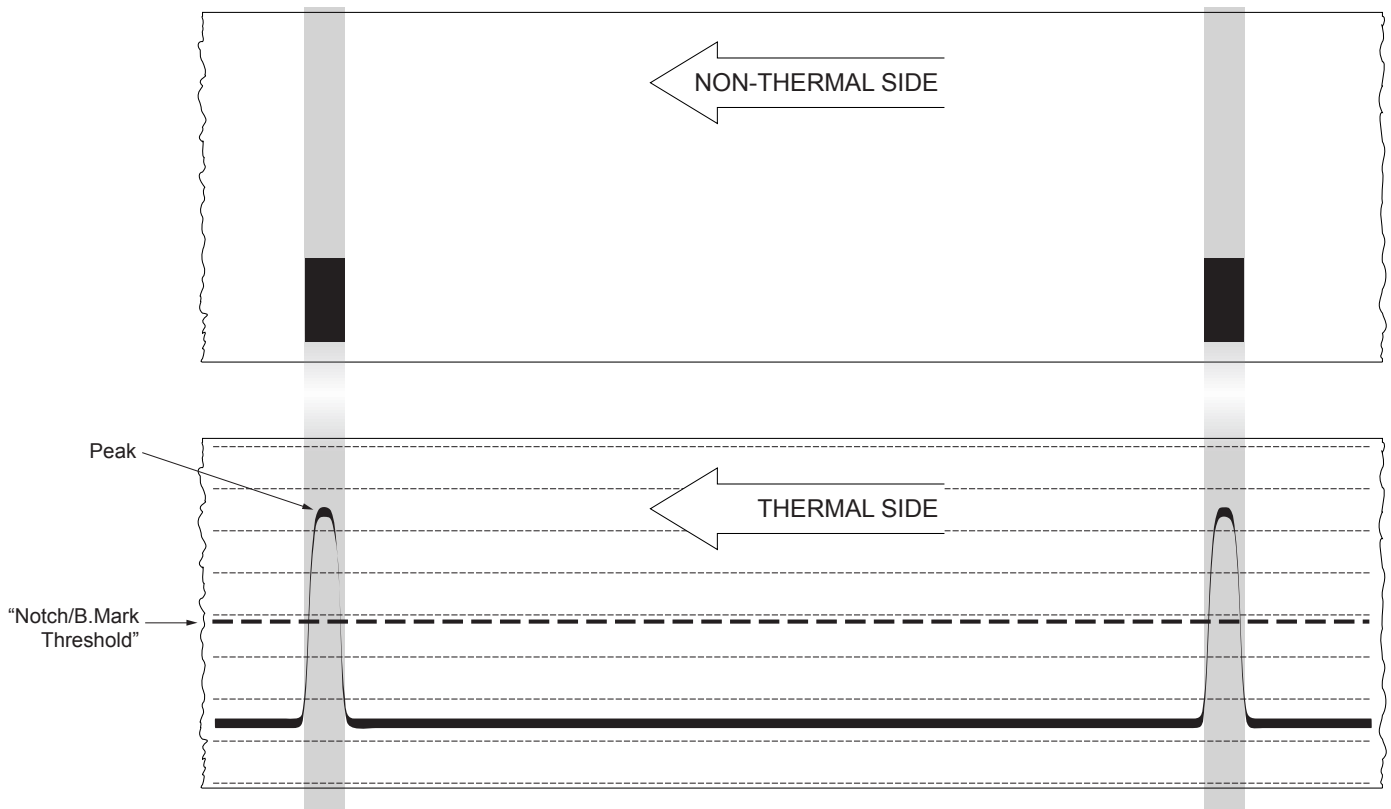

The following figure shows an example of paper with holes: the outgoing voltage is constant while passing the paper between two holes and presents a variation at each hole. In this case, the optimal value for the “Notch/B.Mark Threshold” parameter is placed about half of the variation.

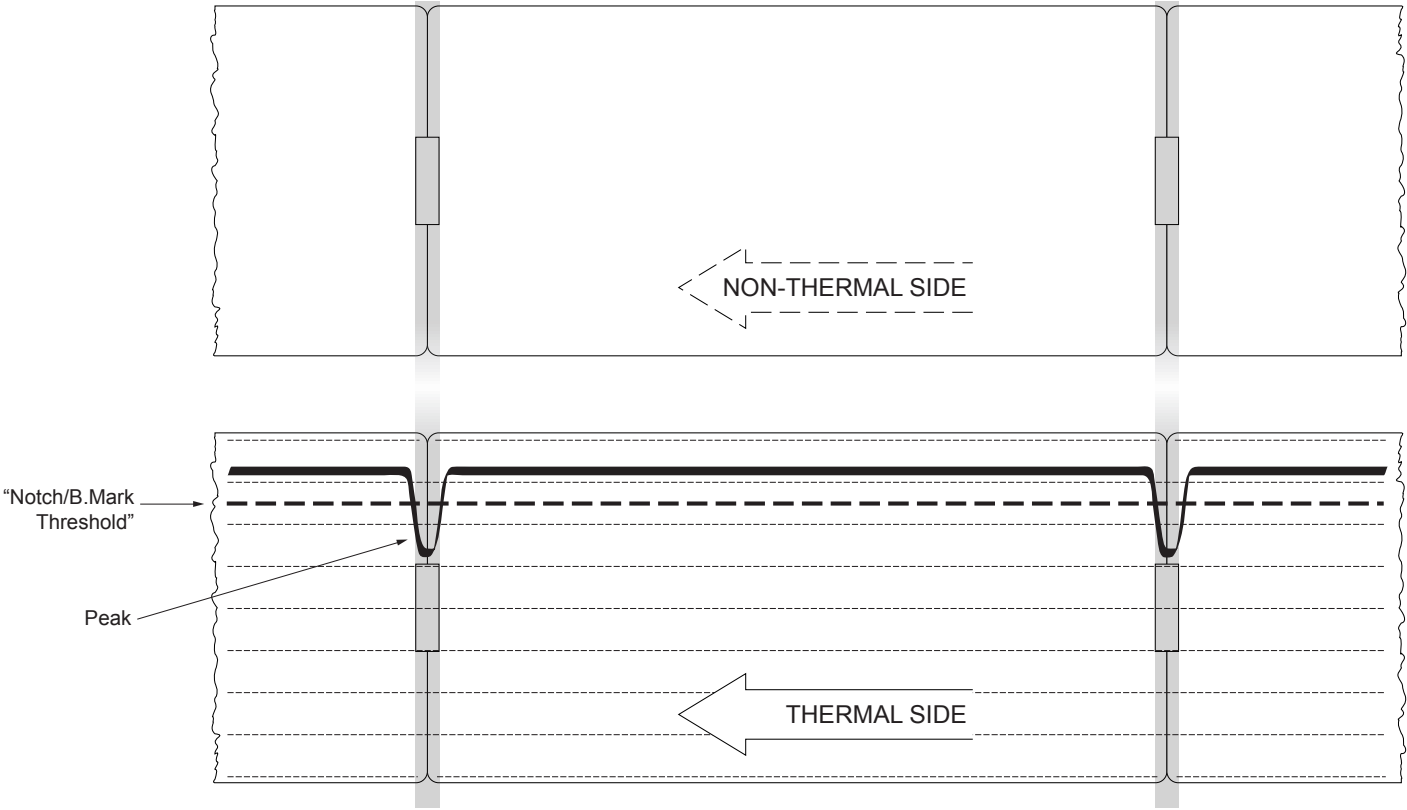

The following figure shows an example of paper with the non-thermal paper printed with black marks and other graphics (for example, a barcode): the outgoing voltage is constant while passing the white paper between two notches, presents a peak at each black mark and presents some “noise” at each barcode. In this case, the optimal value for the “Notch/B.Mark Threshold” parameter is located about halfway between the peak value and the maximum value of the “noise”.

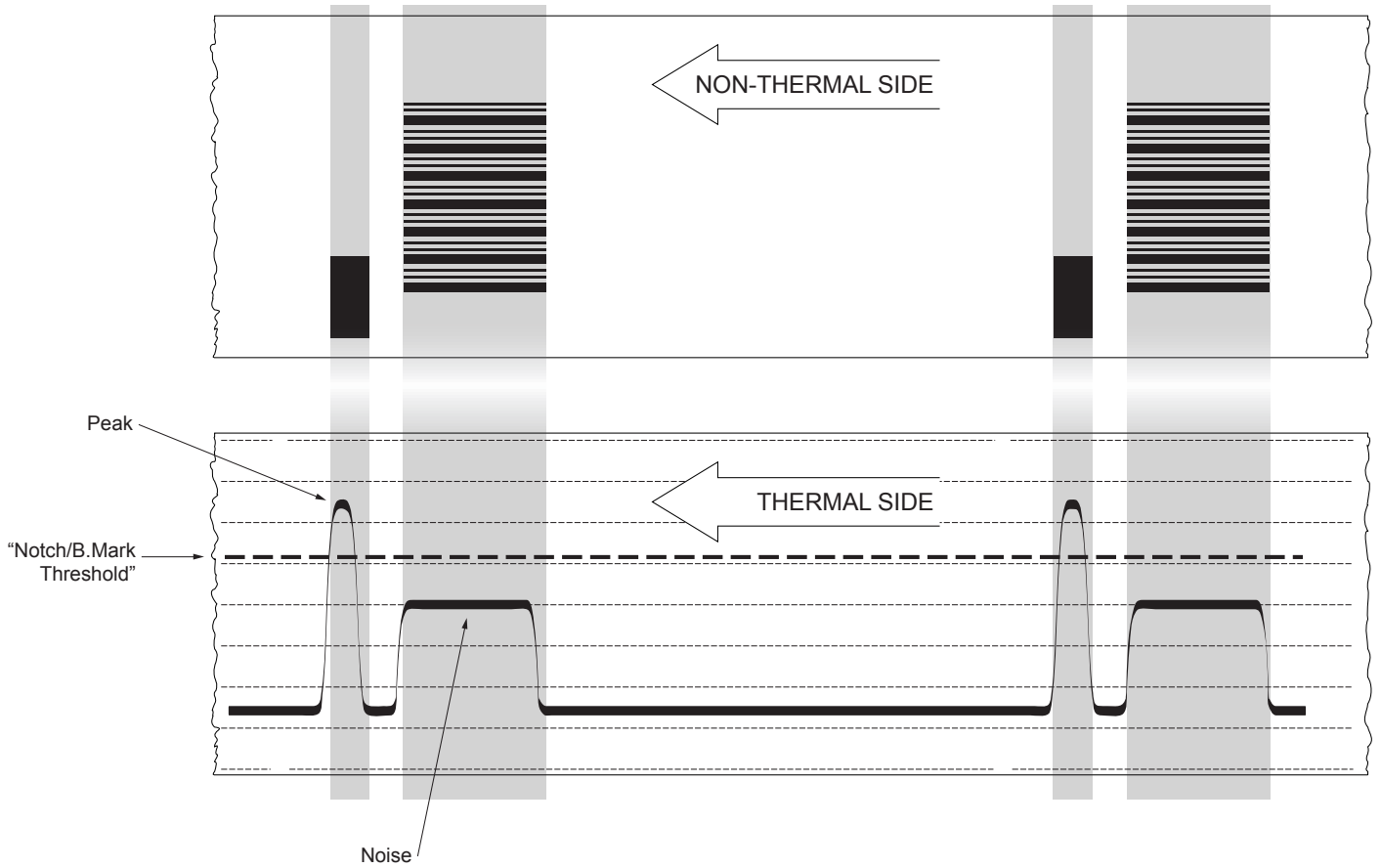

If the maximum value of “noise” read by the sensor is very close to the peak value, it might be difficult to place the value of the “Notch/B.Mark Threshold” at an intermediate point. In these cases, it is mandatory that the portion of paper between the point of printing end and the front notch is completely white (no graphics). In this way, the only next graphic detected by the sensor for alignment after the printing end will be the notch.

10.3 Alignment parameters

The “alignment point” is defined as the position inside the ticket to use for the notch alignment. The distance between the notch edge and the alignment point is defined as “Notch Distance”.

Referring to the front of the notch, the value of “Notch Distance” value varies from 0mm minimum and 99.9 mm maximum.

If the “Notch Distance” value is set to 0, the alignment point is set at the beginning of the notch.

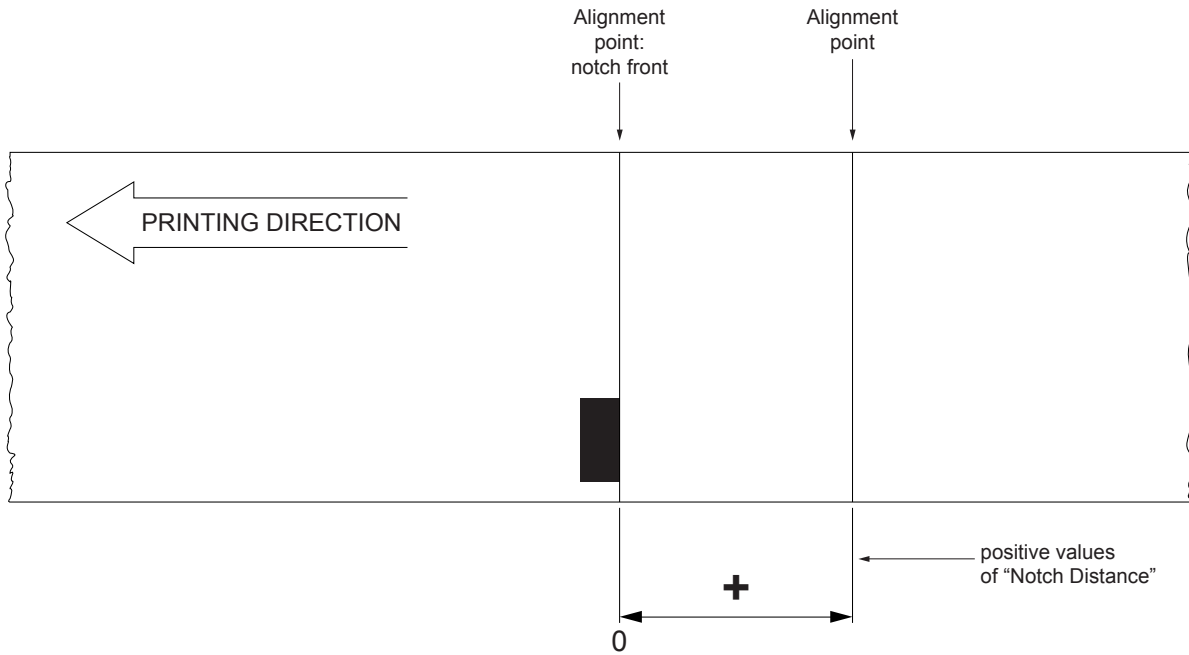

The following figure shows a section of the device with the paper path and the distances (in millimetres) between the alignment sensor, the print head and the cutter (cutting line).

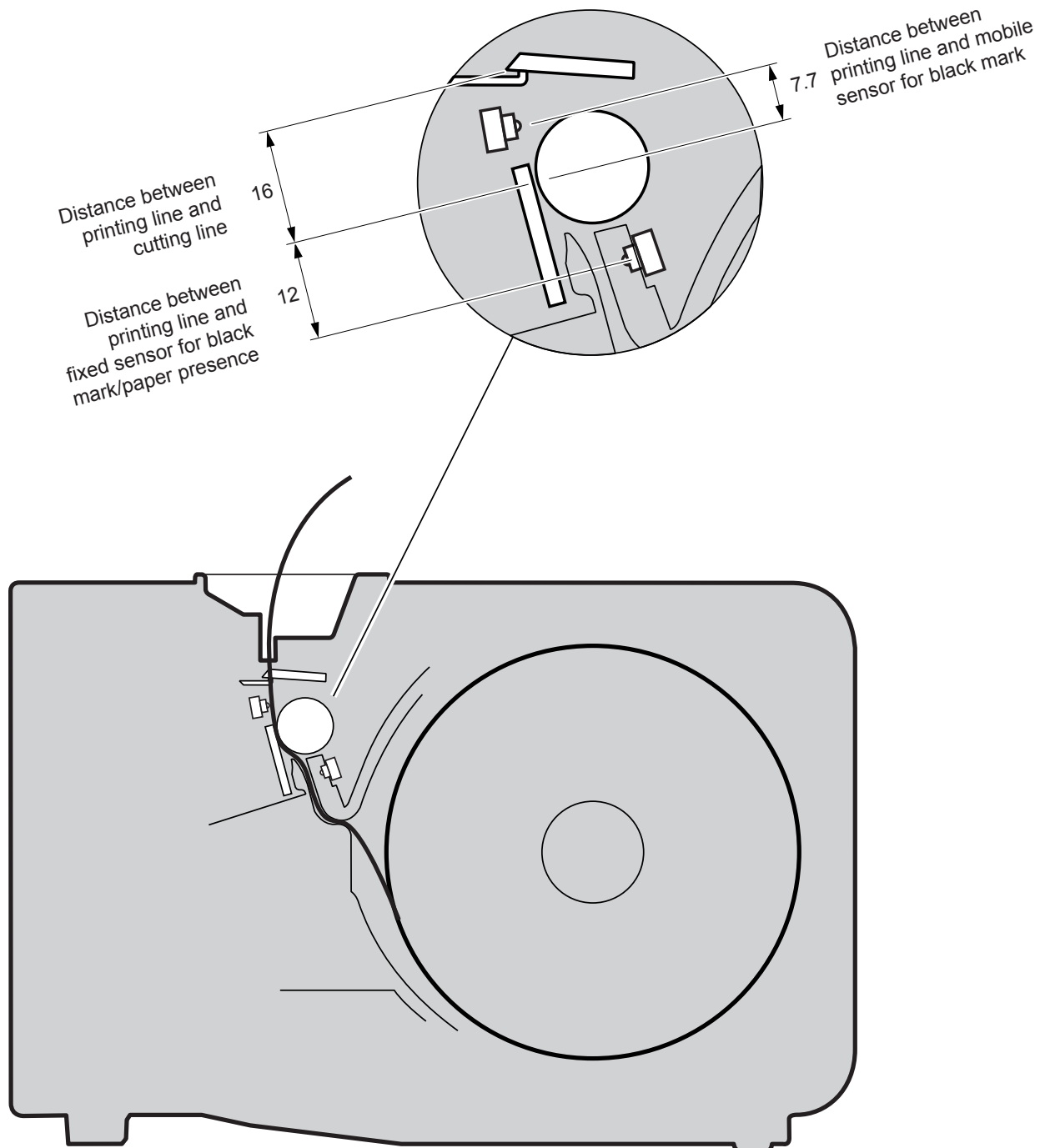

CUSTOM/POS EMULATION

To define the alignment point you need to set the device parameters that compose the numerical value of the “Notch Distance” parameter. (see par.5.4).

For example, to set a notch distance of 15 mm between the notch and the alignment point, the parameters must be set on the following values:

<i>Notch Distance Sign</i>	: +
<i>Notch Distance [mm x 10]</i>	: 1
<i>Notch Distance [mm x 1]</i>	: 5
<i>Notch Distance [mm x .1]</i>	: 0

The “Notch Distance” parameter, may be modified as follows:

- during the Setup procedure of the device (see chapter 5)
- by modifying the Setup.ini file (see par.12.9)
- by using the 0x1D 0xE7 command (for more details, refer to the commands manual)
- by driver

10.4 Printing area

In order to print ticket containing only one notch and to not overlay printing to a notch (that will make it useless for the next alignment), it is important to well calibrate the height of the printing area of ticket according to the inter-notch distance.

The following figure shows an example of tickets with “Notch Distance” set to 0:

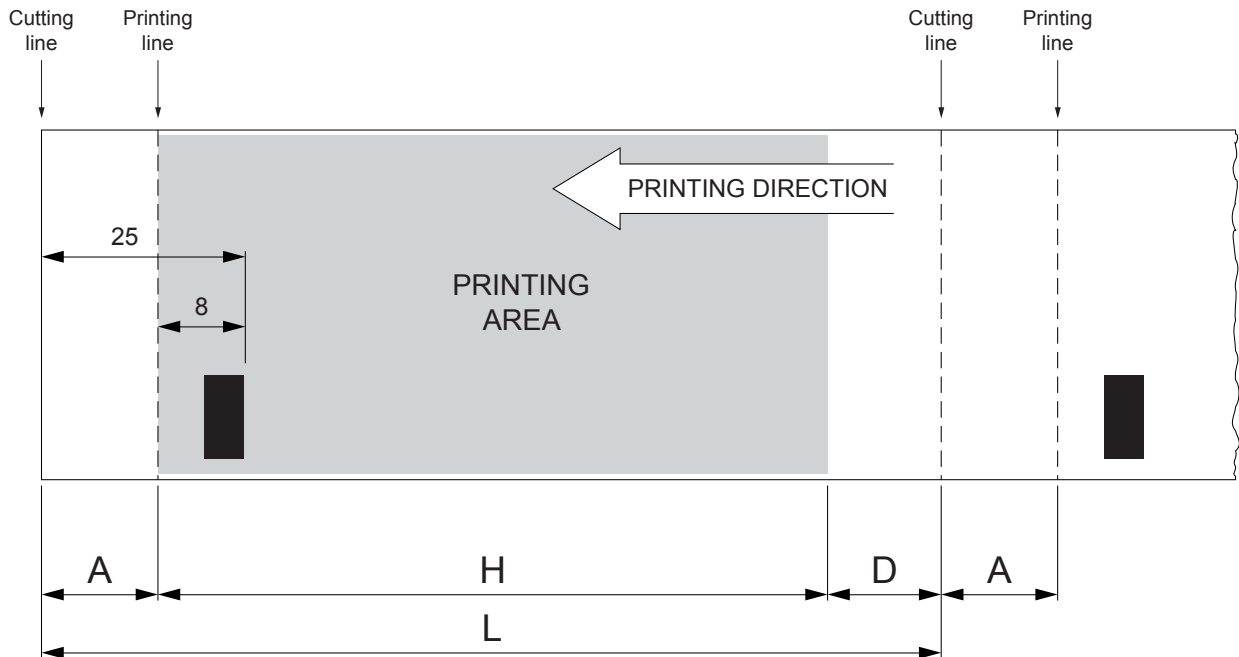

A “Non-printable area” of 17 mm generated from:

“Distance between notch front/cutting line” - “Distance between notch front/printing line”

where:

“Distance between notch front/cutting line” = 25 mm (fixed distance)

“Distance between notch front/printing line” = 8 mm (fixed distance)

H Distance between the first and the last print line, called “Height of the printing area”.

L Ticket length.

D Automatic feed for alignment at the next notch.

To use all the notches on the card, you must comply with the following equation:

$$H + A \leq L$$

The height of the printing area (H) can be increased to make no progress on alignment (D) but no further.

11 TECHNICAL SERVICE

In case of failure, contact the Technical Service by sending an e-mail to support@custom.it detailing:

1. Product code
2. Serial number
3. Hardware release
4. Firmware release

To get the necessary data, proceed as follows:

1



XXXXXXXXXXXXXXXXX Rx
00000000000000000000

Write down the data printed on the product label (see paragraph 2.3)

2

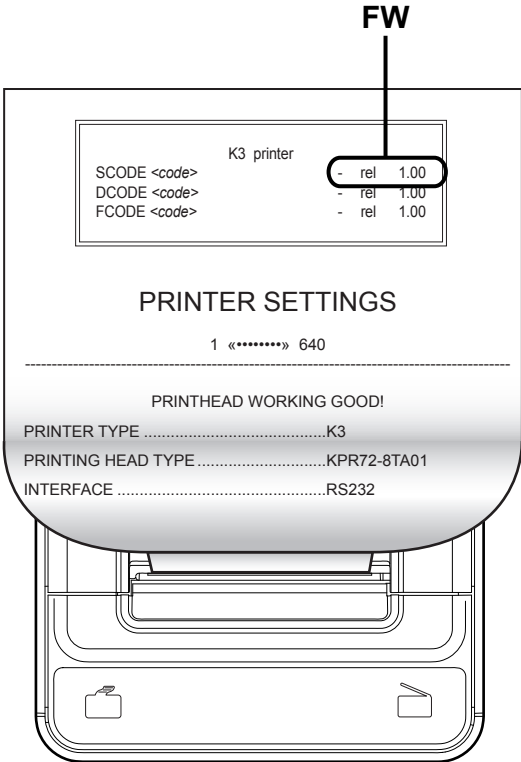

FW

K3 printer

SCODE <code>	- rel 1.00
DCODE <code>	- rel 1.00
FCODE <code>	- rel 1.00

PRINTER SETTINGS

1 «.....» 640

PRINthead WORKING GOOD!

PRINTER TYPEK3

PRINTING HEAD TYPEKPR72-8TA01

INTERFACERS232

Print a Setup report (see paragraph 5.1)
The Setup report shows the firmware release

3



support@custom.it
Customer Service Department

Send an e-mail to the Technical Service, with the data collected

12 ADVANCED FUNCTIONS

12.1 File sharing

The device can be connected to a PC with a USB cable (see par.3.2).

Through this kind of connection, it is possible to manage drivers, fonts and logos of the device and configure the operating parameters by files sharing from Mass Storage.

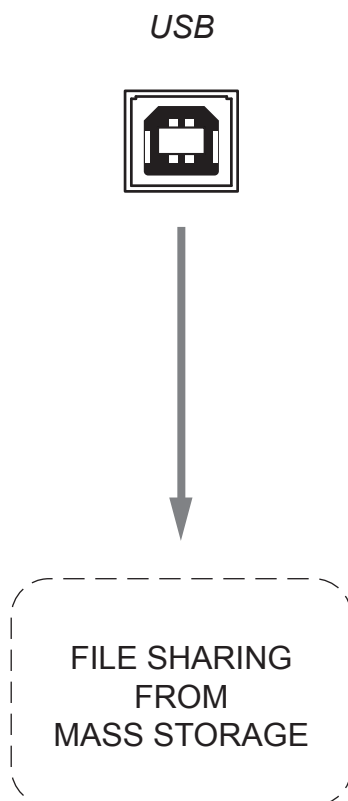

12.2 Drivers installation

It is possible to install the new driver update directly into the folder “DRIVER” on the Flash Drive of the device. To enter the Flash Drive by files sharing from Mass Storage you need to enable the relative parameter during the configuration process (see chapter 5).

12.3 Logos management

It is possible to store new logos in addition to default logos stored on Flash Disk. The device automatically provides to convert BMP image to the error-diffusion format in black and white.

It is possible to directly add the new logo directly into the folder "PICTURES" on the Flash Drive of the device. To enter the Flash Drive by files sharing from Mass Storage, you need to enable the relative parameter during the configuration process (see chapter 5).

After adding the logo, open the configuration file "PictList.ini" and add a new line with a number associated to the logo (to be used with device's commands), a letter for the memory unit and the logo file name, as indicated in the instructions written inside the "PictList.ini" file.

To delete a logos stored in the device, proceed as follows:

1. delete the selected logo from the "Pictures" folder on Flash Disk;
2. in the configuration file "PictList.ini", delete the line related to the erased logo.

The logos stored on Flash Disk and converted by the device, can be printed by using the number associated to the logo during the conversion step.

The correspondence between file-name and logo-number is warrant by the configuration file "PictList.ini" and it is verifiable with the logo test.

12.4 Fonts management

It is possible to store new font in addition to default fonts stored on Flash Disk.

You can directly add the new font directly into the folder “FONTS” on the Flash Drive of the device.

To enter the Flash Drive by files sharing from Mass Storage, you need to enable the relative parameter during the configuration process (see chapter 5).

NOTE:

Uploading the new font directly from the “Font” folder of Microsoft® Windows® directory, remember that the displayed font name into the “Font” folder may not match the real name of the font file.

12.5 Setup

It is possible to configure the default parameters for device setup by editing the "Setup.ini" file on the Flash Drive. To enter the Flash Drive by files sharing from Mass Storage, you need to enable the relative parameter during the configuration process (see chapter 5).

After editing device's parameter, simply save the "Setup.ini" file to make the modifies activated.

The "Setup.ini" file is a configuration file that contains all the configurable parameters listed in text format and divided into some sections (indicated in square brackets).

The available values for every parameter, are listed after the parameter name. The value marked with the symbol ' * ' is the default one. To modify printer's parameters, change the numeric value after the name of parameters. To set the parameter to the default value, change the numeric value with the symbol D.

The "Setup.ini" file permits the configuration of the following parameters:

[PRINT]

Print Mode	0*, 1	0 = Normal 1 = Reverse		
Autofeed	0*, 1	0 = CR disabled 1 = CR enable		
Chars / inch	0, 1*, 2	0 = A=11 B=15 cpi 1 = A=15 B=20 cpi 2 = A=20 B=15 cpi		
Code Table [num]	0			
Chinese font	0*, 1	0 = Disabled 1 = Enabled		
Speed / Quality	0, 1*, 2	0 = High Quality 1 = Normal 2 = High Speed 3 = Grey scale		
Paper Width	0, 1, 2*	0 = 50mm[58 PaperW] 1 = 54mm[60 PaperW] 2 = 72mm[80 PaperW]		
Paper Threshold	0, 1*, 2, 3, 4, 5, 6	0 = 30 % 1 = 40 % 2 = 50 %	3 = 60 % 4 = 70 % 5 = 80 %	6 = 90 %
Notch/B.Mark Position	0*, 1, 2	0 = Disabled 1 = Bottom 2 = Top		
Notch Threshold	0, 1*, 2, 3, 4, 5, 6	0 = 30 % 1 = 40 % 2 = 50 %	3 = 60 % 4 = 70 % 5 = 80 %	6 = 90 %

Notch Distance [mm]

Total cut	0*, 1	0 = Enabled 1 = Disabled
-----------	-------	-----------------------------

PaperEnd Buffer Clear	0*, 1	0 = Disabled 1 = Enabled
-----------------------	-------	-----------------------------

PrintHead Test PowerOn	0*, 1	0 = Disabled 1 = Enabled
------------------------	-------	-----------------------------

Data Logger	0*, 1, 2, 3	0 = Disabled 1 = Text 2 = Graphic 3 = Text + Graphic
-------------	-------------	---

Line Space Reduction	0*, 1, 2, 3	0 = Disabled 1 = 25% 2 = 50% 3 = 75%
----------------------	-------------	---

Line Feed Reduction	0*, 1, 2, 3	0 = Disabled 1 = 25% 2 = 50% 3 = 75%
---------------------	-------------	---

Barcode Height Reduction	0*, 1, 2, 3	0 = Disabled 1 = 25% 2 = 50% 3 = 75%
--------------------------	-------------	---

Print Density	0, 1, 2, 3, 4*, 5, 6, 7, 8	0 = - 50 % 1 = - 37 % 2 = - 25 %	3 = - 12 % 4 = 0 % 5 = + 12 %	6 = + 25 % 7 = + 37 % 8 = + 50 %
---------------	----------------------------	--	-------------------------------------	--

[INTERFACE]

RS232 Baud Rate	1, 2, 3, 4, 5, 6, 7, 8*	1 = 1200 bps 2 = 2400 bps 3 = 4800 bps	4 = 9600 bps 5 = 19200 bps 6 = 38400 bps	7 = 57600 bps 8 = 115200 bps
-----------------	-------------------------	--	--	---------------------------------

RS232 Data Length	0*, 1	0 = 8 bits/chr 1 = 7 bits/chr
-------------------	-------	----------------------------------

RS232 Parity	0*, 1, 2	0 = None 1 = Even	2 = Odd
--------------	----------	----------------------	---------

RS232 Handshaking	0, 1*	0 = Xon/Xoff 1 = Hardware		
Busy Condition	0*, 1	0 = RxFull 1 = OffLine/RxFull		
USB Virtual COM	0*, 1	0 = Disabled 1 = Enabled		
USB Mass Storage	0*, 1	0 = Disabled 1 = Enabled		
USB Address Number	0*, 1, 2, 3, 4, 5, 6, 7, 8, 9	0 = 0 1 = 1 2 = 2 3 = 3	4 = 4 5 = 5 6 = 6 7 = 7	8 = 8 9 = 9

[NETWORK]

DHCP Client	0*, 1	0 = Disabled 1 = Enabled		
FTP Server	0*, 1	0 = Disabled 1 = Enabled		
IP Address				
Subnet Mask				
Default Gateway				
Domain Name System				
TCP Printer Port				
MAC Address (Solo lettura)				

CUSTOM[®]

CUSTOM S.p.A.

World Headquarters

Via Berettine, 2/B - 43010 Fontevivo, Parma ITALY

Tel. +39 0521 680111 - Fax +39 0521 610701

info@custom.biz - www.custom.biz

All rights reserved