

## MCP7H50-H001R30-AO

Mellanox® MCP7H50-H001R30 Compatible TAA Compliant 200GBase-CU QSFP56 to 2xQSFP56 Infiniband HDR Direct Attach Cable (Passive Twinax, 1m, LSZH)

### Features

- PAM4 modulation
- MEET SFF-8636
- MEET IEEE802.3bj & IEEE802.3cd
- Support I2C two - line string interface, easy to control
- 1m length
- Low crosstalk
- Low power
- Operating case temperature: -20°C to +75°C
- Hot pluggable
- RoHS Compliant



### Application

- 10G/40G /100g/200G Ethernet
- Infiniband SDR, DDR, QDR, FDR, EDR, HDR SWITCH
- Router Concentrator
- Data center, cloud server

### Product Description

This is a Mellanox® MCP7H50-H001R30 compatible TAA compliant 200GBase-CU QSFP56 to 2xQSFP56 200G direct attach cable that operates over passive copper with a maximum reach of 1.0m (3.3ft). It has been programmed, uniquely serialized, and data-traffic and application tested to ensure it is 100% compliant and functional. This direct attach cable is TAA (Trade Agreements Act) compliant, and is built to comply with MSA (Multi-Source Agreement) standards. We stand behind the quality of our products and proudly offer a limited lifetime warranty.

AddOn's direct attach cables are RoHS compliant and lead-free.

TAA refers to the Trade Agreements Act (19 U.S.C. & 2501-2581), which is intended to foster fair and open international trade. TAA requires that the U.S. Government may acquire only "U.S. – made or designated country end products."



## Environment Performance

Parameter	Requirement	Test Condition
<b>Operating Temperature Range</b>	-20°C to +75°C	Cable operating temperature range.
<b>Storage Temperature Range (in packed condition)</b>	-40°C to +80°C	Cable storage temperature range in packed condition.
<b>Thermal Cycling Non-Powered</b>	No evidence of physical damage	EIA-364-32D, Method A, -25 to 90C, 100 cycles, 15 min. dwells
<b>Salt Spraying</b>	48 hours salt spraying after shell corrosive area less than 5%.	EIA-364-26
<b>Mixed Flowing Gas</b>	Pass electrical tests per 3.1 after stressing. (For connector only)	EIA-364-35 Class II, 14 days.
<b>Temperature Life</b>	No evidence of physical damage	EIA-364-17C w/ RH, Damp heat 90°C at 85% RH for 500 hours then return to ambient
<b>Cable Cold Bend</b>	4H, No evidence of physical damage	Condition: -20°C±2°C, mandrel diameter is 6 times the cable diameter.
<b>Low Level Contact Resistance</b>	70 milliohms Max. From initial.	EIA-364-23: Apply a maximum voltage of 20mV And a current of 100 mA.
<b>Insulation Resistance</b>	10 Mohm (Min.)	EIA-364-21: AC 300V 1 minute
<b>Dielectric Withstanding Voltage</b>	NO disruptive discharge.	EIA-364-20: Apply a voltage of 300 VDC for 1 minute between adjacent terminals And between adjacent terminals and ground.

## Electrical Performance

Parameter		Requirement	Test Condition																																			
Differential Impedance	Cable Impedance	105+5/-10Ω	Rise time of 25ps (20 % - 80 %).																																			
	Paddle Card Impedance	100±10Ω	Rise time of 25ps (20 % - 80 %).																																			
	Cable Termination Impedance	100±15Ω	Rise time of 25ps (20 % - 80 %).																																			
Differential (Input/Output) Return loss SDD11/SDD22		$\text{Return\_loss}(f) \geq \begin{cases} 16.5-2\sqrt{f} & 0.05 \leq f < 4.1 \\ 10.66-14\log_{10}(f/5.5) & 4.1 \leq f \leq 19 \end{cases}$ <p>Where f is the frequency in GHz Return_loss(f) is the return loss at frequency f</p>	10MHz≤f ≤19GHz																																			
Differential to common-mode (Input/Output) Return loss SCD11/SCD22		$\text{Return\_loss}(f) \geq \begin{cases} 22-(20/25.78)f & 0.01 \leq f < 12.89 \\ 15-(6/25.78)f & 12.89 \leq f \leq 19 \end{cases}$ <p>Where f is the frequency in GHz Return_loss(f) is the Differential to common-mode return loss at frequency f</p>	10MHz≤f ≤19GHz																																			
Common-mode to Common-mode (Input/Output) Return loss SCC11/SCC22		$\text{Return\_loss}(f) \geq 2\text{dB} \quad 0.2 \leq f \leq 19$ <p>Where f is the frequency in GHz Return_loss(f) is the common-mode to common-mode return loss at frequency f</p>	10MHz≤f ≤19GHz																																			
Differential Insertion Loss (SDD21 Max.)		(Differential Insertion Loss Max. For TPa to TPb Excluding Test fixture) <table border="1" style="width: 100%; border-collapse: collapse; text-align: center;"> <thead> <tr> <th>F AWG</th> <th>1.25GHz</th> <th>2.5GHz</th> <th>5.0GHz</th> <th>7.0GHz</th> <th>10GHz</th> <th>12.89GHz</th> </tr> </thead> <tbody> <tr> <td>30 (1m) Max.</td> <td>4.5dB</td> <td>5.4dB</td> <td>6.3dB</td> <td>7.5dB</td> <td>8.5dB</td> <td>10.5dB</td> </tr> <tr> <td>30/28 (3m) Max.</td> <td>7.5dB</td> <td>9.5dB</td> <td>12.2dB</td> <td>14.8dB</td> <td>18.0dB</td> <td>21.5dB</td> </tr> <tr> <td>26 (3m) Max.</td> <td>5.7dB</td> <td>7.2dB</td> <td>9.9 dB</td> <td>11.9dB</td> <td>14.1dB</td> <td>16.5dB</td> </tr> <tr> <td>26/25 (5m) Max.</td> <td>7.8dB</td> <td>10.0dB</td> <td>13.5dB</td> <td>16.0dB</td> <td>19.0dB</td> <td>22.0dB</td> </tr> </tbody> </table>	F AWG	1.25GHz	2.5GHz	5.0GHz	7.0GHz	10GHz	12.89GHz	30 (1m) Max.	4.5dB	5.4dB	6.3dB	7.5dB	8.5dB	10.5dB	30/28 (3m) Max.	7.5dB	9.5dB	12.2dB	14.8dB	18.0dB	21.5dB	26 (3m) Max.	5.7dB	7.2dB	9.9 dB	11.9dB	14.1dB	16.5dB	26/25 (5m) Max.	7.8dB	10.0dB	13.5dB	16.0dB	19.0dB	22.0dB	10MHz≤f ≤19GHz
F AWG	1.25GHz	2.5GHz	5.0GHz	7.0GHz	10GHz	12.89GHz																																
30 (1m) Max.	4.5dB	5.4dB	6.3dB	7.5dB	8.5dB	10.5dB																																
30/28 (3m) Max.	7.5dB	9.5dB	12.2dB	14.8dB	18.0dB	21.5dB																																
26 (3m) Max.	5.7dB	7.2dB	9.9 dB	11.9dB	14.1dB	16.5dB																																
26/25 (5m) Max.	7.8dB	10.0dB	13.5dB	16.0dB	19.0dB	22.0dB																																
Insertion Loss Deviation		$-0.176*f - 0.7 \leq \text{ILD} \leq 0.176*f + 0.7$	50MHz≤f ≤19GHz																																			
Differential to common-mode Conversion Loss-Differential Insertion Loss(SCD21-SDD21)		$\text{Conversion\_loss}(f) - \text{IL}(f) \geq \begin{cases} 10 & 0.01 \leq f < 12.89 \\ \{ 27-(29/22)f & 12.89 \leq f < 15.7 \} \\ 6.3 & 15.7 \leq f \leq 19 \end{cases}$ <p>Where f is the frequency in GHz Conversion_loss(f) is the cable assembly differential to common-mode conversion loss IL(f) is the cable assembly insertion loss</p>	10MHz≤f ≤19GHz																																			
MDNEXT (multiple disturber near-end crosstalk)		≥26dB @12.89GHz	10MHz≤f ≤19GHz																																			
Intra Skew		15ps/m,	10MHz≤f ≤19GHz																																			

## Mechanical and Physical Characteristics

Parameter	Requirement	Test Condition
<b>Vibration</b>	Pass electrical tests per 3.1 after stressing.	Clamp & vibrate per EIA-364-28E, TC-VII, test condition letter – D, 15 minutes in X, Y & Z axis.
<b>Cable Flex</b>	No evidence of physical damage	Flex cable 180° for 20 cycles ( $\pm 90^\circ$ from nominal position) at 12 cycles per minute with a 1.0kg load applied to the cable jacket. Flex in the boot area 90° in each direction from vertical. Per EIA-364-41C
<b>Cable Plug Retention in Cage</b>	90N Min. No evidence of physical damage	Force to be applied axially with no damage to cage. Per SFF 8661 Rev 2.1 Pull on cable jacket approximately 1 ft behind cable plug. No functional damage to cable plug below 90N. Per SFF-8432 Rev 5.0
<b>Cable Retention in Plug</b>	90N Min. No evidence of physical damage	Cable plug is fixtured with the bulk cable hanging vertically. A 90N axial load is applied (gradually) to the cable jacket and held for 1 minute. Per EIA-364-38B
<b>Mechanical Shock</b>	Pass electrical tests Per 3.1 after stressing.	Clamp and shock per EIA-364-27B, TC-G, 3 times in 6 directions, 100g, 6ms.
<b>Cable Plug Insertion</b>	40N Max. (QSFP56)	Per SFF8661 Rev 2.1
<b>Cable plug Extraction</b>	30N Max. (QSFP56)	Place axial load on de-latch to de-latch plug. Per SFF8661 Rev 2.1
<b>Durability</b>	50 cycles, No evidence of physical damage	EIA-364-09, perform plug & unplug cycles: Plug and receptacle mate rate: 250 times/hour. 50 times for QSFP28/SFP28 module (CONNECTOR TO PCB)

## Electrical Pin-Out Details

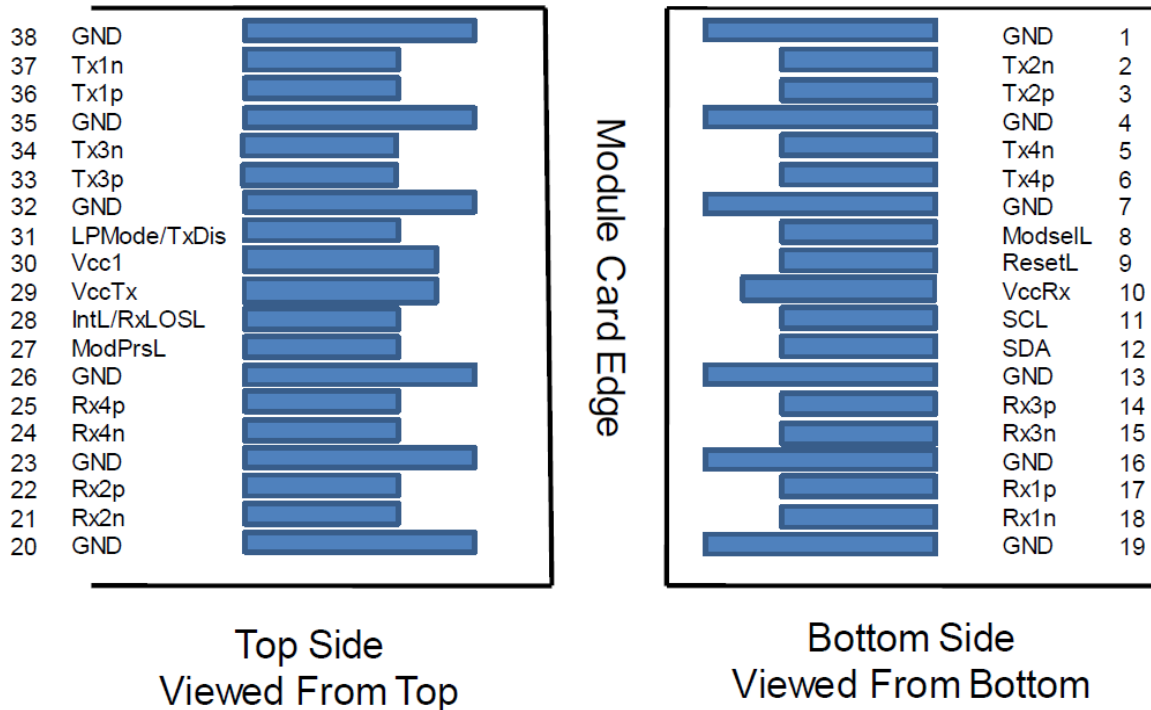

## Pin Descriptions

Pin	Logic	Symbol	Description	Notes
1		GND	Ground	1
2	CML-I	Tx2n	Transmitter Inverted Data Input	
3	CML-I	Tx2p	Transmitter Non-Inverted Data Input	
4		GND	Ground	1
5	CML-I	Tx4n	Transmitter Inverted Data Input	
6	CML-I	Tx4p	Transmitter Non-Inverted Data Input	
7		GND	Ground	1
8	LVTTTL-I	ModSelL	Module Select	
9	LVTTTL-I	ResetL	Module Reset	
10		Vcc Rx	+3.3V Power supply receiver	2
11	LVC MOS-I/O	SCL	2-wire serial interface clock	
12	LVC MOS-I/O	SDA	2-wire serial interface data	
13		GND	Ground	1
14	CML-O	Rx3p	Receiver Non-Inverted Data Output	
15	CML-O	Rx3n	Receiver Inverted Data Output	
16		GND	Ground	1
17	CML-O	Rx1p	Receiver Non-Inverted Data Output	
18	CML-O	Rx1n	Receiver Inverted Data Output	
19		GND	Ground	1
20		GND	Ground	1
21	CML-O	Rx2n	Receiver Inverted Data Output	
22	CML-O	Rx2p	Receiver Non-Inverted Data Output	
23		GND	Ground	1
24	CML-O	Rx4n	Receiver Inverted Data Output	
25	CML-O	Rx4p	Receiver Non-Inverted Data Output	
26		GND	Ground	1
27	LVTTTL-O	ModPrsL	Module Present	
28	LVTTTL-O	IntL	Interrupt	
29		Vcc Tx	+3.3V Power supply transmitter	2
30		Vcc 1	+3.3V Power Supply	2
31	LVTTTL-I	LPMode	Low Power Mode	
32		GND	Ground	1
33	CML-I	Tx3p	Transmitter Non-Inverted Data Input	
34	CML-I	Tx3n	Transmitter Inverted Data Input	

35		GND	Ground	1
36	CML-I	Tx1p	Transmitter Non-Inverted Data Input	
37	CML-I	Tx1n	Transmitter Inverted Data Input	
38		GND	Ground	1

**Note:**

- GND is the symbol for signal and supply (power) common for the QSFP module. All are common within the QSFP module and all module voltages are referenced to this potential unless otherwise noted. Connect these directly to the host board signal-common ground plane.
- Vcc Rx, Vcc1 and Vcc Tx are the receiver and transmitter power supplies and shall be applied concurrently. Vcc Rx, Vcc1 and Vcc Tx may be internally connected within the QSFP transceiver module in any combination. The connector pins are each rated for a maximum current of 500 mA.

**Wiring Diagram**

wire	Starting signal	Starting	End	End signal
W1	RX1+	X1.17	X2.36	TX1+
	RX1-	X1.18	X2.37	TX1-
	GND	X1.19	X2.38	GND
	TX1+	X1.36	X2.17	RX1+
	TX1-	X1.37	X2.18	RX1-
	GND	X1.38	X2.19	GND
W2	GND	X1.20	X2.1	GND
	RX2-	X1.21	X2.2	TX2-
	RX2+	X1.22	X2.3	TX2+
	GND	X1.1	X2.20	GND
	TX2-	X1.2	X2.21	RX2-
	TX2+	X1.3	X2.22	RX2+

wire	Starting signal	Starting	End	End signal
W3	RX3+	X1.14	X3.36	TX1+
	RX3-	X1.15	X3.37	TX1-
	GND	X1.16	X3.38	GND
	TX3+	X1.33	X3.17	RX1+
	TX3-	X1.34	X3.18	RX1-
	GND	X1.35	X3.19	GND
W4	GND	X1.23	X3.1	GND
	RX4-	X1.24	X3.2	TX2-
	RX4+	X1.25	X3.3	TX2+
	GND	X1.4	X3.20	GND
	TX4-	X1.5	X3.21	RX2-
	TX4+	X1.6	X3.22	RX2+

**Mechanical Specification**

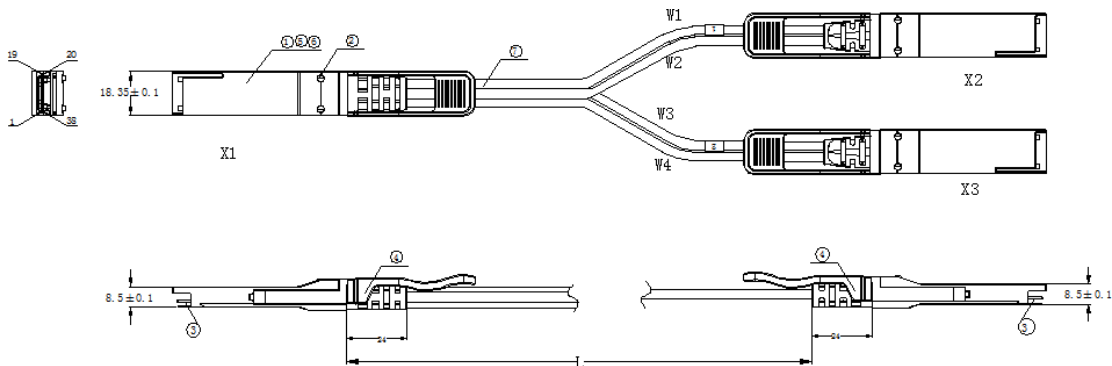

## **About AddOn Networks**

In 1999, AddOn Networks entered the market with a single product. Our founders fulfilled a severe shortage for compatible, cost-effective optical transceivers that compete at the same performance levels as leading OEM manufacturers. Adhering to the idea of redefining service and product quality not previously had in the fiber optic networking industry, AddOn invested resources in solution design, production, fulfillment, and global support.

Combining one of the most extensive and stringent testing processes in the industry, an exceptional free tech support center, and a consistent roll-out of innovative technologies, AddOn has continually set industry standards of quality and reliability throughout its history.

Reliability is the cornerstone of any optical fiber network and is engrained in AddOn's DNA. It has played a key role in nurturing the long-term relationships developed over the years with customers. AddOn remains committed to exceeding industry standards with certifications from ranging from NEBS Level 3 to ISO 9001:2005 with every new development while maintaining the signature reliability of its products.

## **U.S. Headquarters**

Email: [sales@addonnetworks.com](mailto:sales@addonnetworks.com)

Telephone: +1 877.292.1701

Fax: 949.266.9273

## **Europe Headquarters**

Email: [salesupportemea@addonnetworks.com](mailto:salesupportemea@addonnetworks.com)

Telephone: +44 1285 842070