

# Quick Start Guide

## Terms & Conditions

# SAMSUNG

# Galaxy XR

### Read this document before operating the product

Read this document before operating the mobile device, accessories, or software (defined collectively and individually as the "Product") and keep it for future reference. This document contains important Terms and Conditions. Electronic acceptance, opening the packaging, use, or retention of the Product constitutes acceptance of these Terms and Conditions.



QR code for Samsung use  
Printed in Korea  
GH68-57309A\_REV\_1.1

### In the box

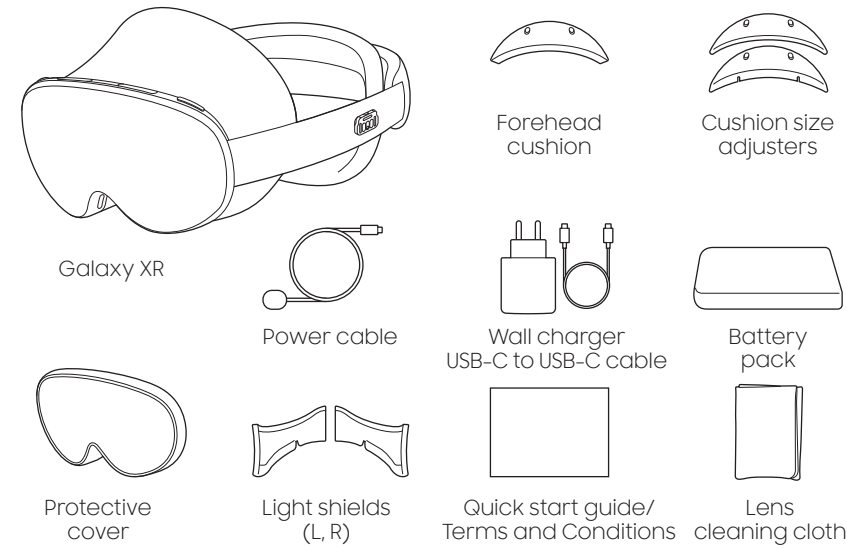

### Your device

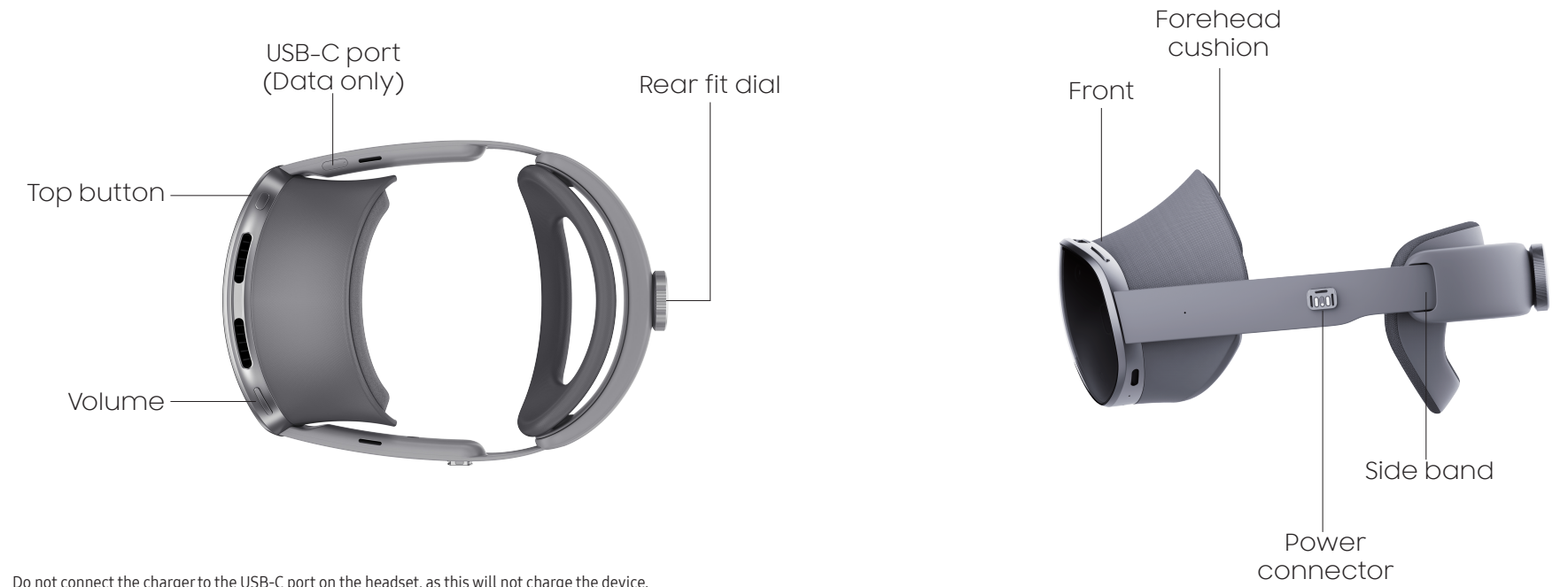

Do not connect the charger to the USB-C port on the headset, as this will not charge the device.

### Wear the device

The device should rest on your forehead, held in place by the band around your head. It should not rest on your nose or cheekbones.

- 1 Remove the Protective cover and put on the device, adjusting its position on your forehead until the center of the screen is clear.
- 2 You can turn the rear fit dial to adjust the device to fit your head and hold the device securely in place.

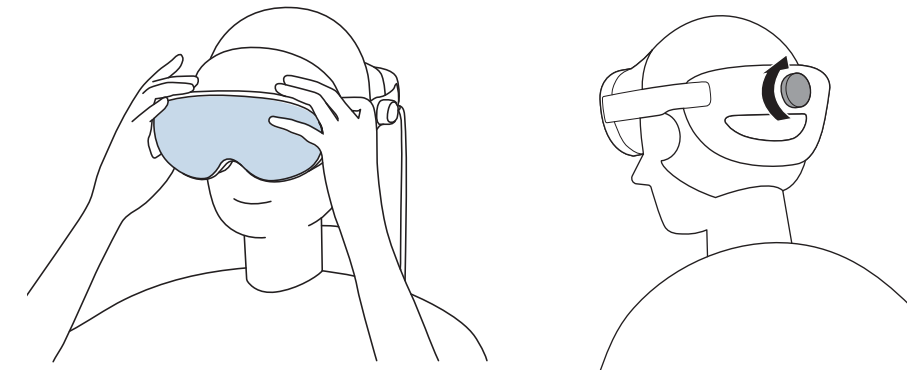

**CAUTION!** Avoid extended continuous use of the headset. Take regular breaks to rest your eyes; take more frequent and longer breaks if you feel discomfort. Consult a healthcare professional if you have serious or persistent discomfort.

### Set up the device

The first time you use your device, you'll set it up.

- 1 Remove the Protective cover, ensure the device is connected to the Battery pack using the Power cable, and then put on the device.
- 2 Follow the on-screen instructions to set up the device, or tap **Set up manually** to complete set-up.

### Your Samsung account

You'll be prompted to sign in to your Samsung account.

For more info on the privacy policy, visit [samsung.com/us/account/privacy-policy/](https://samsung.com/us/account/privacy-policy/)



### Find the user guide

The user guide is available on the device, under **Settings > User guide**.

### Power the device

Before using the device, charge the Battery pack. The Battery pack must be attached to the device while you're using it. You can also use the device while the Battery pack is connected to the Wall charger.

### Charge the Battery pack

- 1 Connect one end of the USB-C cable to the USB-C port on the Battery pack, and the other end to the Wall charger.
- 2 Connect the Wall charger into a wall outlet. The indicator light shows charging status.

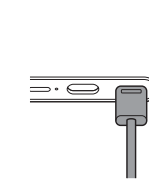

Power cable and USB Type-C accessory cable included. Use only compatible charging devices and accessories. Damage caused by use of accessories which are not compatible may not be covered by warranty. If battery pack heats up or malfunctions, the indicator light will blink. If this happens, disconnect the headset power cable from the battery pack, and let the pack cool before using.

**CAUTION!** To avoid electric shock and damaging your device, do not charge it while it is wet or near liquids. Do not handle device, charger or cords with wet hands.

**CAUTION!** Battery pack contains Lithium-ion (Li-ion) batteries; do not dispose of as household waste.

### Power the device while wearing it

- 1 Slide the cable end of the Power cable into the Power connector on the device until it clicks, and insert the other end of the Power cable into the center port on the Battery pack.
- 2 Connect the Battery pack to the Wall charger with the USB-C cable, and then connect the Wall charger to a wall outlet. While wearing the device, keep the Battery pack close to you, such as in a pocket, and keep the connection to the Wall charger and power outlet close by and free from obstructions while wearing the device.

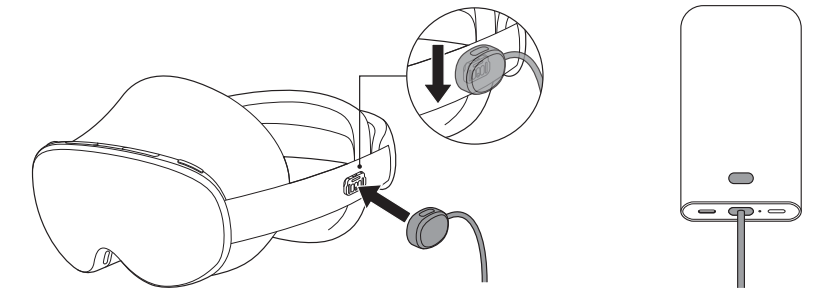

When not using the device, unplug the Power cable from the headset.

## Customize the fit

Use the provided accessories for the best fit.

- Adjust the distance between the screen and your eyes using the Cushion size adjusters.
- Block any unnecessary light coming from the outside by using the Light shields.
- Rotate the Rear fit dial to adjust how the device fits around your head.

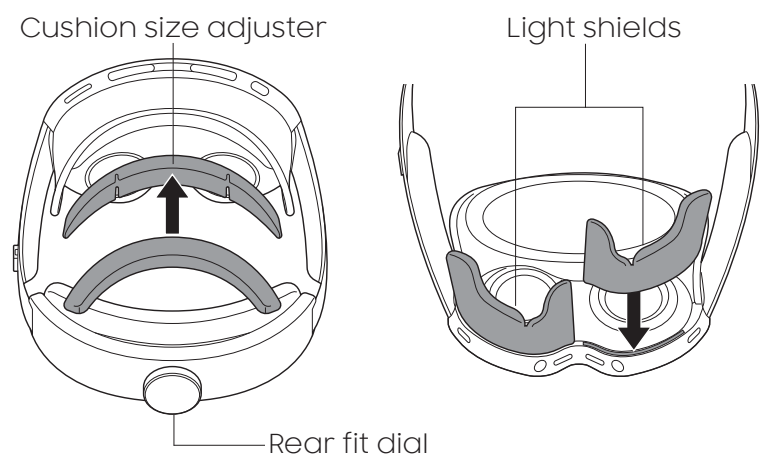

## Use optional prescription lenses (sold separately)

If you wear prescription glasses, you can order optional prescription lens inserts from a Samsung partner, to use with your Galaxy XR. Lens inserts are sold and delivered separately.

- 1 Align the left and right lens inserts by matching the circular L and R engravings.
- 2 Press the lens inserts into the device.

The first time you wear the device with the lenses, follow the on-screen prompts for set-up instructions.

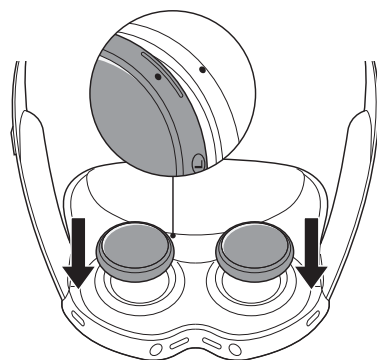

## Terms & Conditions

### Important legal information

Read this document before operating the mobile device, accessories, or software (defined collectively and individually as the “Product”) and keep it for future reference. This document contains important Terms and Conditions. Electronic acceptance, opening the packaging, use, or retention of the Product constitutes acceptance of these Terms and Conditions.

You can obtain a copy of the complete Terms and Conditions and Samsung Standard One-year Limited Warranty by contacting Samsung at the address or phone number provided in this document.

Dispute Resolution Agreement - This Product is subject to a binding Dispute Resolution Agreement, which includes arbitration terms, between you and SAMSUNG ELECTRONICS AMERICA, INC. (“Samsung”). You can opt out within 30 calendar days of purchase: email [optout@sea.samsung.com](mailto:optout@sea.samsung.com) or call 1-800-SAMSUNG (726-7864) and providing the applicable information.

The Dispute Resolution Agreement, Standard One-year Limited Warranty, End User License Agreement (EULA), and additional Health, Safety and Device care information, including:

- Device Temperature
- Samsung Knox security platform
- Maintaining Dust and Water Resistance (IP rating)
- Location, Navigation, GPS and AGPS

### Responsible listening

**CAUTION!** Avoid potential hearing loss by not exposing yourself to loud sounds for a prolonged period of time. For more information, visit [www.samsung.com/us/support/legal/mobile](http://www.samsung.com/us/support/legal/mobile) then select **Health and Safety Information > Responsible listening**

### Safety information

Read all safety information before using the device to ensure safe and proper use. You can access more safety information by opening **Settings > About headset > Legal information > Safety information**

When you are not using the device, to prevent damage, store it on a secure flat surface with the Protective cover attached.

Be careful not to bend the Power cable where it connects to the Battery pack to avoid damage to the cable.

The device can be used in locations with an ambient temperature of 0 °C to 30 °C. You can store the device at an ambient temperature of -20 °C to 45 °C. Using or storing the device outside of the recommended temperature ranges may damage the device or reduce the battery's lifespan.

Do not expose the device to physical impact or damage.

If any part of the device, such as the glass or acrylic body, is broken, smokes, or emits a burning odor, stop using the device immediately. Use the device again only after it has been repaired at a Samsung Service Center or an authorized service center.

### FCC Part 15 Information and Notices

This device complies with part 15 of the FCC Rules. Operation is subject to conditions: (1) This device may not cause harmful interference, and (2) this device must accept any interference received, including interference that may cause undesired operation. Operate devices that support wireless power sharing at least 8 inches/20 cm away from your body.

### FCC Radiation Exposure Statement

This equipment complies with FCC Radiation exposure limits set forth for an uncontrolled environment. This device and its antenna must not be co-located or operating in conjunction with any other antenna or transmitter.

### Pacemaker and implantable medical devices

**CAUTION!** Persons who have implantable medical devices should consult their health care provider before using mobile electronic devices. For more information, visit [www.samsung.com/us/support/legal/mobile](http://www.samsung.com/us/support/legal/mobile) then select **Health and Safety Information > FCC Part 15 Information and Notices**

**WARNING!** Your Samsung device contains magnets. Keep it away from credit cards and devices that may be affected by magnets. Keep your Samsung device more than 6 in./15cm away from medical devices. If you suspect interference with a medical device, stop using your Samsung device and consult your medical provider.

### Safe Handling & Recycling of Batteries and Electronics

**WARNING!** Never dispose of batteries in a fire because they may explode. Do not disassemble, crush, puncture, heat, burn or reuse batteries. For more information, visit [call2recycle.org](http://call2recycle.org) or call 1-800-822-8837.

**Dispose of unwanted electronics through an approved recycler:** To find the nearest recycling location, go to our website [www.samsung.com/recycling](http://www.samsung.com/recycling) or call 1-800-SAMSUNG (726-7864).

### Class 1 Laser Information

This product is classified as a class 1 laser product per IEC 60825-1 Ed. 3.0:2014. This product complies with 21 CFR 1040.10 and 1040.11 except for conformance with IEC 60825-1 Ed. 3., as described in Laser Notice No. 56, dated May 8, 2019.

**CAUTION:** Use of controls or adjustments or performance of procedures other than those specified herein may result in hazardous radiation exposure. There is no user service possible on the embedded laser module. Contact Samsung for service.

CLASS 1 LASER PRODUCT

- Wireless Emergency Alerts (WEA)
- Hearing Aid Compatibility (HAC)

are available at:

English: [www.samsung.com/us/support/legal/mobile](http://www.samsung.com/us/support/legal/mobile)

Spanish: [www.samsung.com/us/support/legal/mobile-sp](http://www.samsung.com/us/support/legal/mobile-sp)

This information is also on the device:

**Settings > About headset > Legal information**

You can access the Federal Communications Commission (FCC) certification, if applicable, by opening **Settings > About headset > Status information**.

### Diagnostic software

This device may be equipped with diagnostic software reporting usage and performance information used to assess, deliver and improve network quality and the overall device experience to wireless customers. Please refer to your service provider's terms and conditions or privacy policy for more information.

### Specific Absorption Rate (SAR) certification information

For information visit:

- [www.fcc.gov/general/radio-frequency-safety-0](http://www.fcc.gov/general/radio-frequency-safety-0)
- [www.fcc.gov/encyclopedia/specific-absorption-rate-sar-cellular-telephones](http://www.fcc.gov/encyclopedia/specific-absorption-rate-sar-cellular-telephones)
- [www.samsung.com/sar](http://www.samsung.com/sar)

The headset front visor window contains glass. Avoid impacts or any materials that might scratch or break the visor window. If the visor window is broken while you are using the device, hold the front frame securely, rotate the rear fit dial, and remove the device carefully. Do not use the device if the visor window is broken or severely scratched.

When cleaning the speaker, use a soft brush or cotton swab to remove any foreign materials.

When cleaning the visor window, use the supplied cleaning cloth. For more information about how to clean the device, refer to the user guide.

Do not share the device with people who have infectious diseases or illnesses or the symptoms of such diseases or illnesses on their eyes, skin, or scalp. There is a risk of infection with infectious diseases or illnesses, such as conjunctivitis.

There may be swelling, itching, and other irritation to parts of your body that have come into contact with the device, such as the scalp, during use. If the symptoms of skin irritation continue, stop using the device and consult a physician.

**Samsung Electronics America, Inc.**  
700 Sylvan Avenue  
Englewood Cliffs, NJ 07632  
Phone: 1-800-SAMSUNG (726-7864)  
Internet: [www.samsung.com](http://www.samsung.com)