

SMART Board®
M Pro
series interactive displays

Installation and maintenance guide

IDX55-5 | IDX65-5 | IDX75-5 | IDX86-5



Was this document helpful?
smarttech.com/docfeedback/171980

SMART®

Important information

Before installing or using a SMART Board® M Pro series interactive display, review the important information included with the display. If you cannot find this information, it is available online.

See > docs.smarttech.com/kb/171931

Learn more

This guide and other resources for the SMART Board M Pro series interactive display are available in the Support section of the SMART website (smarttech.com/support). Scan this QR code to view these resources on your mobile device.



ENERGY STAR is the government-backed symbol for energy efficiency, providing simple, credible, and unbiased information that consumers and businesses rely on to make well-informed decisions. ENERGY STAR-certified products are the simple choice for energy efficiency, making it easy for consumers and businesses to make purchases that save them money and protect the environment. The U.S. EPA ensures that each product that earns the label is independently certified to deliver the quality, performance, and savings that users have come to expect.

As shipped, your display delivers ENERGY STAR performance and savings. However, changing some settings may increase energy consumption beyond the limits required for ENERGY STAR certification. For example, increased brightness and contrast will increase power consumption.

Please consider the environment when you choose non-ENERGY STAR settings.



License

The terms HDMI, HDMI High-Definition Multimedia Interface, HDMI trade dress and the HDMI Logos are trademarks or registered trademarks of HDMI Licensing Administrator, Inc.



Trademark notice

SMART Board, SMART TeamWorks, SMART Meeting Pro, Object Awareness, smarttech, the SMART logo and all SMART taglines are trademarks or registered trademarks of SMART Technologies ULC in the U.S. and/or other countries. Google, Android, Chrome, and Google Drive are trademarks of Google Inc. Microsoft, Windows, and OneDrive are either registered trademarks or trademarks of Microsoft Corporation in the United States and/or other countries. Mac, macOS, iOS, and AirPlay are trademarks of Apple Inc., registered in the U.S. and other countries. Intel and Core are trademarks of Intel Corporation in the U.S. and/or other countries. All other third-party product and company names may be trademarks of their respective owners.

Copyright notice

© 2024 SMART Technologies ULC. All rights reserved. No part of this publication may be reproduced, transmitted, transcribed, stored in a retrieval system or translated into any language in any form by any means without the prior written consent of SMART Technologies ULC. Information in this manual is subject to change without notice and does not represent a commitment on the part of SMART.

This product and/or use thereof is covered by one or more of the following U.S. patents:

www.smarttech.com/patents

September 18, 2024

Contents

Chapter 1 Welcome	5
About this guide	5
About the display	6
More information	8
Chapter 2 Installing and maintaining the display	9
Is this the first time you've installed or maintained a SMART Board interactive display?	9
Installing the display	10
Installing SMART OPS appliances	11
Connecting to a network	11
Connecting power and turning on the display for the first time	13
Adjusting the display's settings	14
Updating iQ system software	14
Chapter 3 Connecting computers and other devices	15
Installing SMART software	16
Connecting room computers and guest laptops	16
Connecting other devices	22
Connector diagrams	27
Chapter 4 Troubleshooting	30
Troubleshooting the display and related SMART products	30
Contacting your reseller for additional support	30
Appendix A Managing the display using RS-232	31
Configuring the serial interface settings	31
Commands and responses	33
Power state commands	35
Input commands	35
Brightness commands	35
Freeze commands	36
Screen shade commands	36
Speaker commands	36
Firmware version commands	36
Model number commands	37
Serial number commands	37
Part number commands	37
Asynchronous messages	37

Contents

Appendix B Enrolling the display in SMART Remote Management 39
Certification and compliance 40

Chapter 1 **Welcome**

About this guide	5
About the display	6
More information	8

The SMART Board® M Pro series interactive display is the hub of your meeting room.

About this guide

This guide explains how to install and maintain a SMART Board M Pro series interactive display. It includes the following information:

- How to install the display and maintain it for years of use
- How to connect devices
- How to update the display
- Where to find troubleshooting information

In addition, this guide includes information about the display's support for RS-232 management and SMART Remote Management.

This guide is intended for those who install and maintain displays in their organizations. Other documentation and resources are available for those who use displays.

See > *More information* on page 8

About the display

If you need to install or maintain the display, take this tour to familiarize yourself with its components:

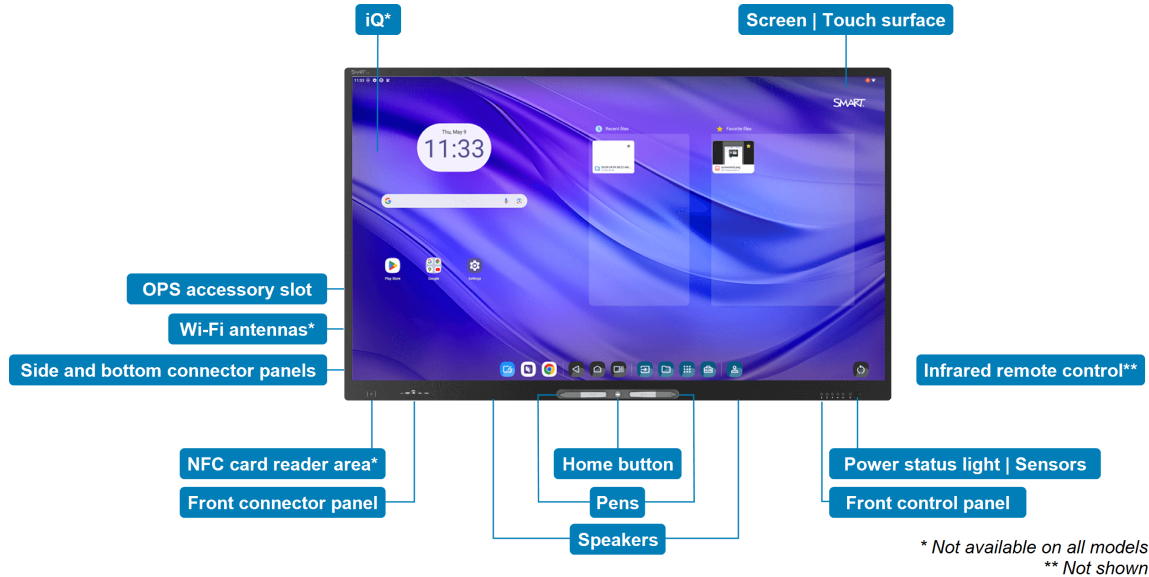

Component	Description	In this guide
iQ	<p>iQ is the embedded Android operating system on non-high-secure SMART Board M Pro series interactive display models.</p> <p>iQ runs on Android 13 (or later) and is EDLA-licensed by Google™.</p> <p>When you turn on the display for the first time, you're prompted to configure iQ.</p> <p>By default, the display downloads and installs iQ updates automatically. You can also download and install updates manually.</p>	<p>See > Page 13</p> <p>See > Page 14</p>
Screen Touch surface	<p>The display comes in the following screen sizes:</p> <ul style="list-style-type: none"> • 55" • 65" • 75" • 86" 	
Pens	<p>The display comes with two pens, which users can use to write or draw on the screen.</p> <p>Replace a pen if its nib becomes worn to prevent damage to the screen or impairment of pen and finger detection.</p>	

Component	Description	In this guide
Power status light Sensors	<p>The power status light indicates the display's status:</p> <ul style="list-style-type: none"> • When the power status light is red, the display is in Standby mode. • When the power status light is green, the display is in normal operating mode. <p>The display includes an infrared sensor that works with the infrared remote control and an ambient light sensor that can detect the brightness of the room and adjust the screen's brightness accordingly.</p> <p>You can enable or disable the ambient light sensor feature.</p>	
Infrared remote control	<p>When you first install and configure the display, you can use the infrared remote control to turn the display on or off, switch inputs, and view and change settings.</p> <p>After installation and configuration, you can give the remote to users for use with the display.</p>	
Home button	<p>Users can press the Home button to return to the iQ home screen at any time.</p>	
Front control panel	<p>The front control panel contains buttons for turning the display on and off, controlling the volume, freezing and unfreezing the screen, and showing and hiding a screen shade.</p>	
Front connector panel	<p>The front connector panel includes connectors for up to two computers or other devices as well as USB peripherals. It's typically used to connect users' laptops and peripherals and other devices users bring with them.</p>	
Side and bottom connector panels	<p>The side and bottom connector panels include connectors for multiple computers, peripherals, and other devices. They are typically used for room computers, peripherals, and other devices that are connected to the display all the time.</p>	
OPS accessory slot	<p>You can install a SMART OPS appliance, such as a SMART OPS PC module, in the OPS accessory slot.</p>	See > Page 11

Component	Description	In this guide
Wi-Fi antennas	You can use Wi-Fi (if you're using a display model that includes Wi-Fi) or Ethernet to connect to your organization's network. The displays require internet access to download updates to iQ, as do Google services and some apps.	See > Page 11
Speakers	The display includes two integrated speakers, designed to provide sound at the front of a room. As an alternative to using these integrated speakers, you can connect an external audio system.	See > Page 25
NFC card reader area	Non-high-secure SMART Board M Pro series interactive displays' integrated RFID NFC reader/writer supports a variety of contactless identification cards. You can use third-party, CCID compatible NFC cards and software with features such as logging in to Windows or other operating systems on a connected computer.	

More information

In addition to this guide, SMART provides other documents for the display in the Support section of the SMART website (smarttech.com/support).

Scan the QR code on page 2 to view links to SMART Board M Pro series interactive display documents and other support resources.

Chapter 2 Installing and maintaining the display

- Is this the first time you've installed or maintained a SMART Board interactive display? 9
- Installing the display 10
- Installing SMART OPS appliances 11
- Connecting to a network 11
- Connecting power and turning on the display for the first time 13
- Adjusting the display's settings 14
- Updating iQ system software 14

Is this the first time you've installed or maintained a SMART Board interactive display?

If you haven't installed or maintained a SMART Board interactive display before, refer to the SMART Board interactive display installation and maintenance hub for general instructions and best practices for installing and maintaining a display, including:

- Moving the display to the installation site
- Mounting the display on a wall, floor stand, or mobile stand
- Configuring the display after installation
- Regularly cleaning and maintaining the display to keep it in the best possible condition

! Important

Before you clean the display's screen, shut down or disconnect the computer. Otherwise, you may scramble the desktop icons or inadvertently activate applications when you wipe the screen.



See also > *SMART Board interactive display installation and maintenance best practices*
(docs.smarttech.com/kb/171035)

Installing the display

SMART recommends that only trained installers install SMART Board interactive displays.

Warning

Improper installation of a display can result in injury and product damage.

Caution

- Avoid setting up and using the display in an area with excessive levels of dust, humidity, or smoke.
- Make sure an electrical socket is near the display and remains easily accessible during use.
- The display should be used only with European TN and TT power distribution systems.

It is not suitable for older, IT-type power distribution systems found in some European countries. This system (IT-type) is widely used isolated from earth, in some installations in France, with impedance to earth, at 230/400V, and in Norway, with voltage limiter, neutral not distributed, at 230V line-to-line.

Contact qualified personnel if you're uncertain of the type of power system available where you're installing the display.

Important

- There are critical software updates for the display that you need to install to ensure the display is fully functional and provides the best experience. Connect the display to a network with internet access to automatically download and apply these updates as well as future updates.
- Refer to the display's specifications for its normal operating power requirements, additional requirements, and other information.

Note

For users in Australia and New Zealand: SMART does not provide stands for use in Australia and New Zealand, nor can we provide recommendations for stands from other vendors.

Refer to the illustrated installation instructions included with the display for specific information about installing it. If you've misplaced these instructions, they're also available online.

See > *SMART Board M Pro series TAA illustrated installation instructions*
(docs.smarttech.com/kb/171944)

Installing SMART OPS appliances

The display includes an OPS accessory slot in which your organization can install a SMART OPS PC module.

See > support.smarttech.com/accessories/computing-modules-and-appliances

Caution

- Only SMART-provided OPS appliances are supported in SMART Board interactive displays. Third-party OPS appliances are not supported, and their use can lead to poor performance or damage to the display.
- Do not install or remove the OPS appliance while the display is turned on. First make sure the power switch on the back of the display beside the AC power inlet is in the OFF (O) position. If you can't reach the power switch, use the front control panel's power button  to put the display in Standby mode, and then unplug the display's power cable from the power outlet.
- After you have turned the display's power switch off or unplugged it, wait at least 30 seconds before removing the appliance to allow its internal power supplies to discharge completely. You might also wait five minutes to give the appliance the opportunity to cool, if necessary.
- Make sure the OPS appliance is secured to the display with screws through the two anchor points. Inadequately secured appliances can damage the display. (An OPS appliance's anchoring screws are typically captive, although some simply include separate anchoring screws.)

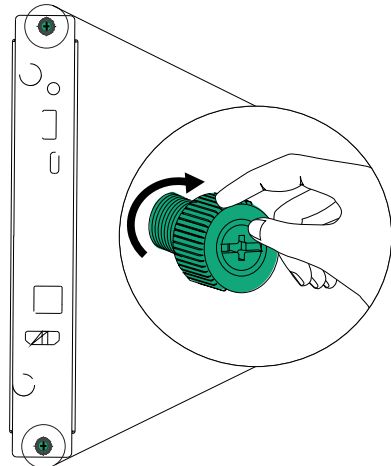

Connecting to a network

Before connecting the display, your organization's network administrators need to configure the network to allow users to update the display's firmware automatically and to use all the iQ features.

See > support.smarttech.com/docs/iq4pronetworksetup

The display requires an internet connection for downloading software and firmware updates, and a number of the iQ apps require a network connection as well. You can connect to the network with Wi-Fi or with an Ethernet cable attached to one of the RJ45 jacks.

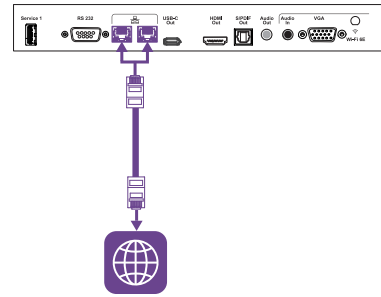

! **Important**

High-secure models do not include Wi-Fi.

Tip

If you're using one of the display's RJ45 jacks to connect to a network, you can connect a computer to the other RJ45 jack to provide network access for the computer. This is particularly useful if only one wired network connection is available in the room. Network access is available when Networked Standby is enabled in Settings but not when Standby is enabled.

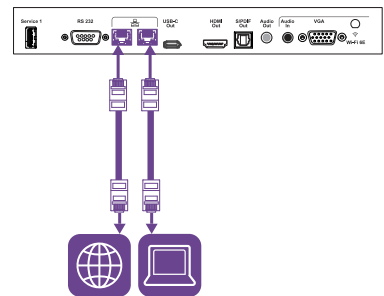

Notes

- If you are connecting the display to the network with Wi-Fi, the display's Wi-Fi channel availability and restrictions will depend on the country defined in system settings.
- If enabled, hotspot connections only use the 2.4 GHz and 5 GHz bands, not 6 GHz bands.

Connecting power and turning on the display for the first time

The final step in installing and configuring the display is to connect power, turn the display on, and configure iQ (if the display has iQ) following the steps in the wizard.

To connect the display to power

Connect the supplied power cable from the AC power inlet on the back of the display to a power outlet.

55" and 65" models

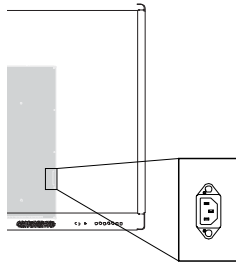

75" models

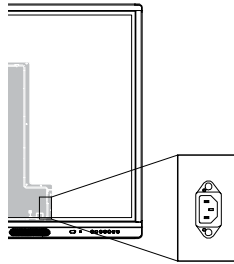

86" models

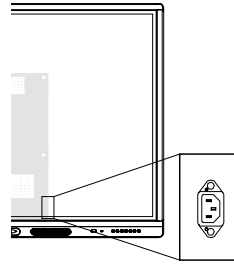

Note

Refer to the display's specifications for power requirements and power consumption information.

To turn on the display for the first time and configure iQ (if the display has iQ)

⚠ Important

The display needs an internet connection for downloading and installing important updates. Ask the network administrator to confirm that the network has been correctly configured for iQ.

See > *Connecting to a network* on page 11

Notes

- Touch is not available immediately after waking or turning on the display. Wait a few seconds, and then the display will respond to touch.
- If a USB drive is connected to the display's service port receptacle, do not remove the USB drive. The USB drive may contain an important firmware update.

1. Flick the switch beside the AC power inlet to the ON (I) position.

55" models

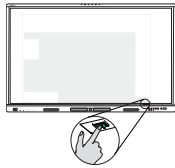

65" models



75" and 86" models

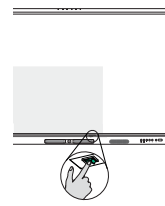

2. If the display has iQ, follow the steps in the wizard to configure iQ.

See > support.smarttech.com/docs/iq4prosetup

Adjusting the display's settings

You might need to adjust the display's settings when you initially install it or while maintaining it.

See > support.smarttech.com/docs/iq4prosettings

Updating iQ system software

SMART periodically releases updates to iQ system software. Depending on how you configure iQ, these updates download and install automatically or need to be downloaded and installed manually.

See > support.smarttech.com/docs/iq4proudates

Chapter 3 Connecting computers and other devices

- Installing SMART software 16
- Connecting room computers and guest laptops16
 - Viewing a connected computer’s input 21
 - Setting a connected computer’s resolution and refresh rate 21
- Connecting other devices 22
 - Connecting USB drives, peripherals, and other devices 23
 - Connecting a second SMART Board interactive display 24
 - Connecting an external display 24
 - Connecting an external video source 25
 - Connecting an external audio system 25
 - Connecting room control systems 26
- Connector diagrams 27
 - Side and bottom connector panels 27
 - Front connector panel 29

 **Warning**
Ensure that any cables that cross the floor to the display are properly bundled and marked to avoid a trip hazard.

Installing SMART software

The display comes with SMART software that you can install on connected room computers and guest laptops or access online. Other SMART software is optional.

Included



SMART Meeting Pro



SMART Product Drivers
and Ink

**SMART
Remote
Management**

SMART Remote
Management¹

Optional



SMART TeamWorks Room

See > smarttech.com/downloads

Connecting room computers and guest laptops

You can connect cables for room computers and guest laptops. By installing cables in advance, you make use of connectors that might not be accessible after the display is wall-mounted. You can then run the cables across floors or behind walls as needed.

¹Subscription for the length of the warranty; only included for models with iQ

- **USB-C 1**

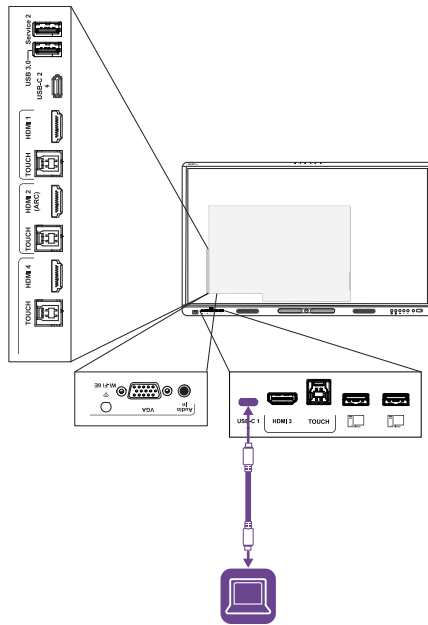

Video/audio/touch/network

Connector	USB-C 1
Standard	USB 3.2 Gen 1×1 (as DFP) Display Port 1.2.4-lane (as UFP)

- **USB-C 2**

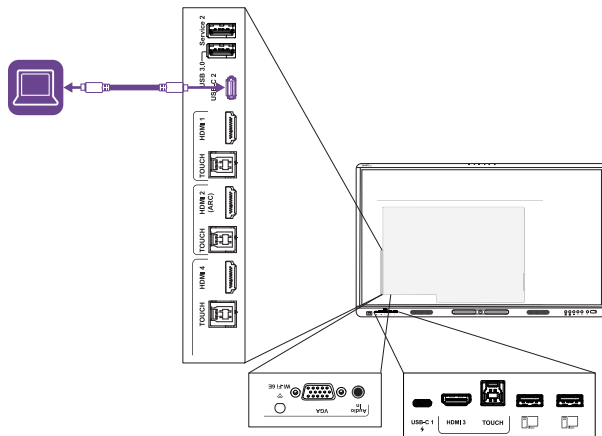

Video/audio/touch/network

Connector	USB-C 2
Standard	USB 3.2 Gen 1×1 (as DFP) Display Port 1.2.4-lane (as UFP)

- **HDMI 1**

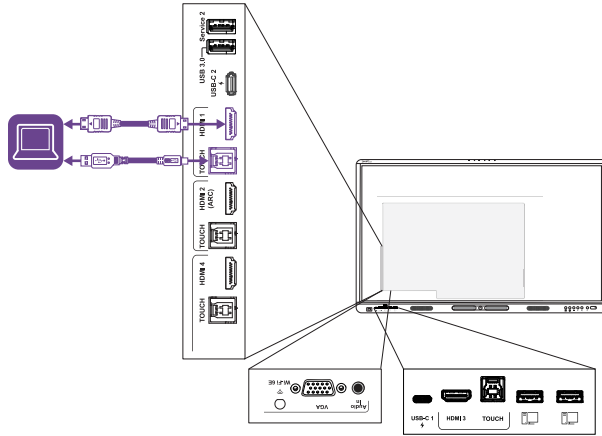

Video/audio

Connector HDMI 1

Standard HDMI 2.1

Touch

Connector Touch (USB Type-B)

Standard USB 3.2 Gen 1

- **HDMI 2**

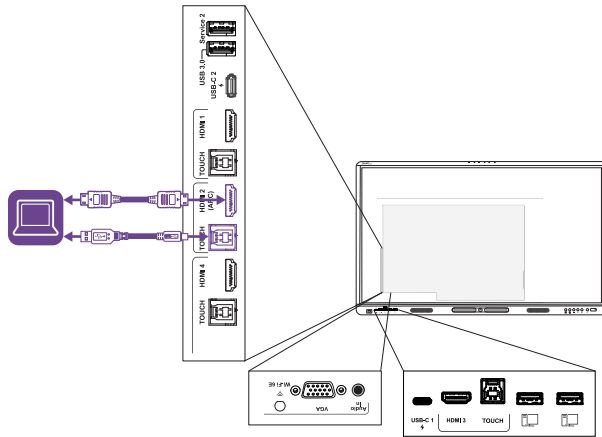

Video/audio

Connector HDMI 2

Standard HDMI 2.1

Touch

Connector Touch (USB Type-B)

Standard USB 3.2 Gen 1

• HDMI 3

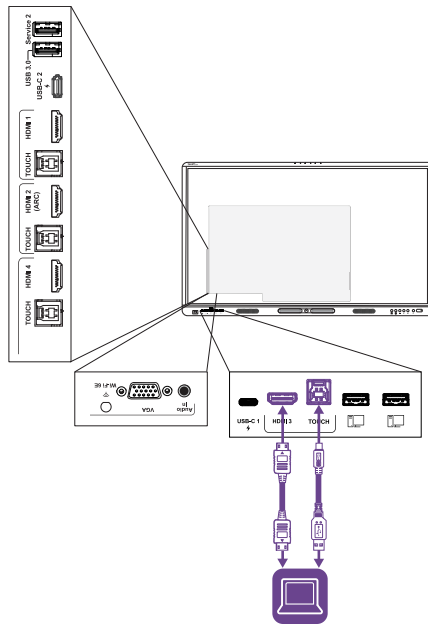

Video/audio

Connector HDMI 3

Standard HDMI 2.1

Touch

Connector Touch (USB Type-B)

Standard USB 3.2 Gen 1

• HDMI 4

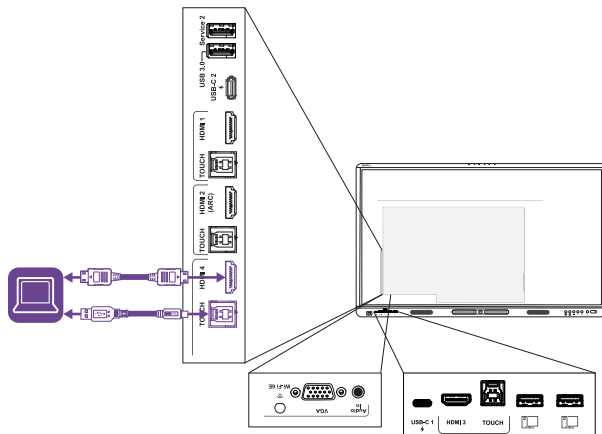

Video/audio

Connector HDMI 4

Standard HDMI 2.1

Touch

Connector Touch (USB Type-B)²

Standard USB 3.2 Gen 1

²The HDMI 4 and VGA inputs share a USB Type-B receptacle.

• **VGA**

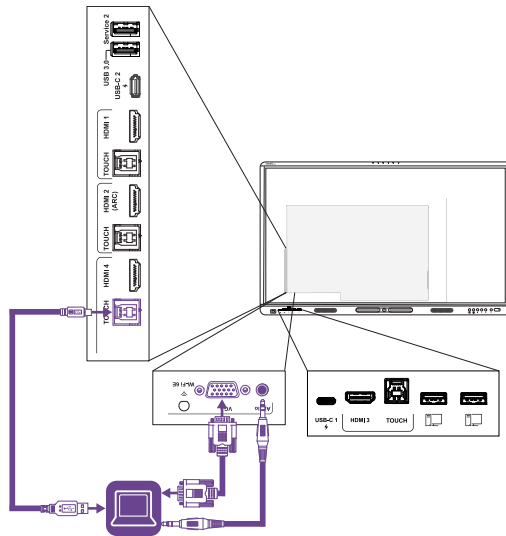

Video

Connector VGA

Standard VGA

Audio

Connector Audio In (Stereo 3.5 mm)

Standard Stereo 3.5 mm

Touch

Connector Touch (USB Type-B)³

Standard USB 3.2 Gen 1

Caution

When connecting a USB cable to a computer, make sure the computer has a USB compliant interface and bears the USB logo. In addition, the USB source computer must be compliant with IEC 62368-1. The source computer must be CE marked and carry safety certification marks for Canada and USA. This is for operating safety and to avoid damage to the display.

Notes

- A room computer or guest laptop connected to the display through a USB Type-B or Type-C receptacle has access to any networks connected to the display by Ethernet while the computer is the currently selected input on the display.





See > [Connecting to a network](#) on page 11

- Install SMART software on any computers you connect to the display.

See > [Installing SMART software](#) on page 16

- If a connected computer reports “Too many USB hubs” or “cannot start (code 10),” see the knowledge base article, [SMART Board interactive displays and USB tier structure use](#).

Viewing a connected computer's input

1. Connect the computer to the display.
2. View the available inputs in one of the following ways:
 - If the display has iQ, tap **Input**  on the Home screen.
 - OR
 - If the display doesn't have iQ, press the **Home** button .
 - Press **Input**  on the front control panel.
 - Press **Input**  on the remote control.

The input selection menu appears.

3. Tap the computer's input menu option.

Setting a connected computer's resolution and refresh rate

This table presents the recommended resolutions and refresh rates for the display's USB-C and HDMI inputs:

Resolution	Input aspect ratio	Mode	Refresh rate
3840 × 2160	16:9	UHD/2160p	59.94 Hz/60 Hz 50 Hz 29.97 Hz/30 Hz 25 Hz 23.98 Hz/24 Hz
1920 × 1080	16:9	FHD/1080p	59.94 Hz/60 Hz 50 Hz 29.97 Hz/30 Hz 25 Hz 23.98 Hz/24 Hz
1360 × 768	16:9	HD	60.015 Hz
1366 × 768	16:9	HD	60.015 Hz
1280 × 720	16:9	HD/720p	59.94 Hz/60 Hz 50 Hz 29.97 Hz/30 Hz 25 Hz 23.98 Hz/24 Hz
720 × 480	16:9	480p (DVD Player)	60 Hz

This table presents the recommend resolutions and refresh rates for the display's VGA input:

Resolution	Input aspect ratio	Mode	Refresh rate
1920 × 1080	16:9	N/A	60.000 Hz
1600 × 1200	4:3	N/A	60.000 Hz
1360 × 768	16:9	N/A	60.015 Hz
1280 × 1024	5:4	SXGA 60	60.020 Hz
1024 × 768	4:3	XGA 60	60.004 Hz
		XGA 70	70.069 Hz
		XGA 75	75.029 Hz
800 × 600	4:3	SVGA 60	60.317 Hz
		SVGA 72	72.188 Hz
		SVGA 75	75.000 Hz
640 × 480	4:3	VGA 60	59.940 Hz

If possible, set connected computers to these resolutions and refresh rates. See the connected computers' operating system documentation for instructions.

See also > support.smarttech.com/docs/resandrefreshrates

Connecting other devices

In addition to computers, you can connect a variety of other devices to the display:

- USB drives, peripherals, and other devices
- External displays
- External video sources
- External audio systems
- Room control systems

Connecting USB drives, peripherals, and other devices

The display includes the following USB receptacles. You can connect USB drives, peripherals (such as keyboards), and other devices to these receptacles and use the devices with iQ, connected computers, and OPS modules installed in the OPS accessory slot.

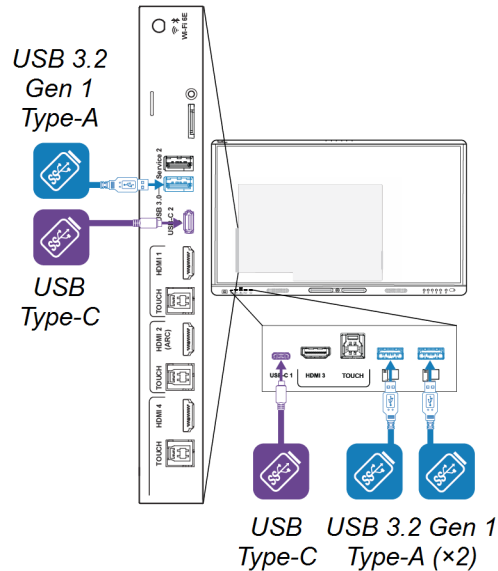

This table shows the supported USB speeds for each input:

Input	USB 2.0 Type-A	USB 3.2 Gen 1 Type-A	USB Type-C
iQ	Hi-Speed	SuperSpeed	SuperSpeed
USB-C 1	Hi-Speed	Hi-Speed	Hi-Speed
USB-C 2	Hi-Speed	Hi-Speed	Hi-Speed
HDMI 1	Hi-Speed	SuperSpeed	SuperSpeed
HDMI 2	Hi-Speed	SuperSpeed	SuperSpeed
HDMI 3	Hi-Speed	SuperSpeed	SuperSpeed
HDMI 4	Hi-Speed	SuperSpeed	SuperSpeed
VGA	Hi-Speed	SuperSpeed	SuperSpeed
OPS accessory slot	Hi-Speed	SuperSpeed	SuperSpeed

Notes

- Hi-Speed = 480 Mbps
- SuperSpeed = 5 Gbps

- You can charge devices using the display's USB Type-C receptacles:

Receptacle	Location	Maximum charging capacity
USB-C In 1	Front connector panel	30 W
USB-C In 2	Side connector panel (when a module is not installed in the accessory slot)	65 W
USB-C Out	Side connector panel.	4.5 W

Connecting a second SMART Board interactive display

You can connect the SMART Board interactive display to a second display by connecting a USB cable from the first display's USB Type-C Out receptacle to one of the second display's USB Type-C In receptacles.

The same input appears on both displays, and users can interact with the input by touching, writing on, drawing on, or erasing on either display.

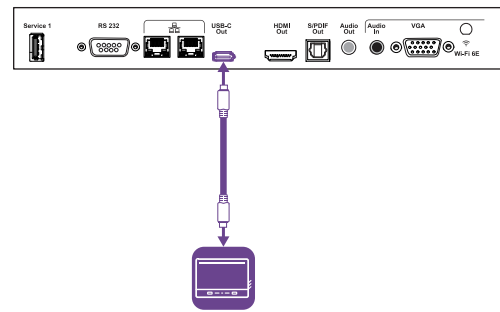

Connecting an external display

You can connect an external display to models that have an HDMI Out connector on the connector panel. The external display will show the same image. This is useful when you're using the display in an auditorium or other large space where it would be beneficial to have a second display.

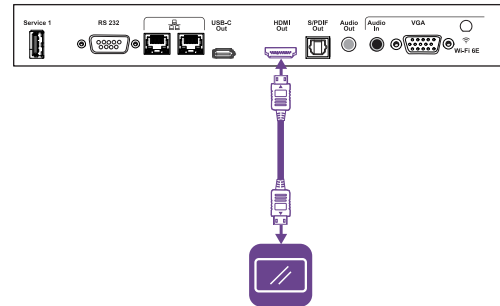

! Important

If the connected external display doesn't support HDCP, the image on the external display is limited to 480p resolution. For full resolution output, connect a display that supports HDCP.

Connecting an external video source

You can connect an external video source, such as a DVD player, media box, or cable box, to your display using an HDMI cable and any of the HDMI connectors on the display's connector panels. To view the source content, switch to the connected HDMI input.

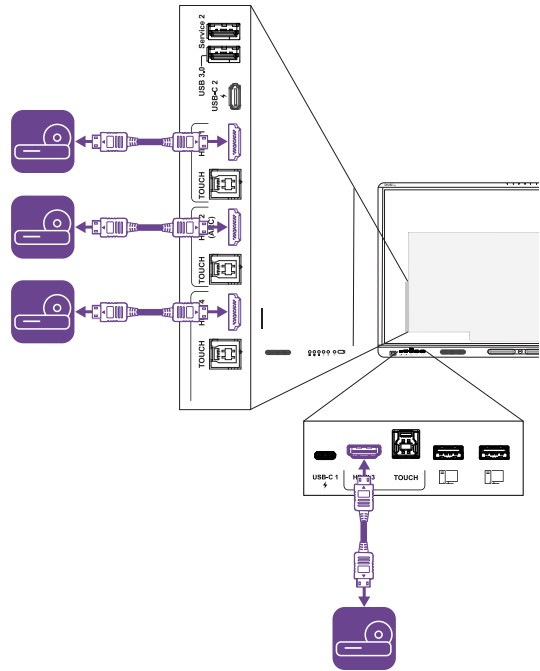

Connecting an external audio system

The display includes two speakers, which are designed to provide sound at the front of a room. You might want to connect an external audio system if you're providing sound in a larger space.

You can connect the display to an external audio system using the Stereo 3.5 mm Out connector. This disables the display's internal speakers. Alternatively, you can connect an external audio system directly to a room computer.

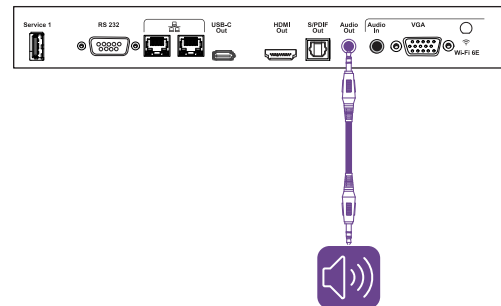

In addition to the Stereo 3.5 mm Out connector, the display provides a Sony/Philips Digital Interface (S/PDIF) Out connector. S/PDIF is a digital audio transmission medium. You need an audio system that has an S/PDIF input to decode this connection to analog. Most external sound bars include an S/PDIF connector.

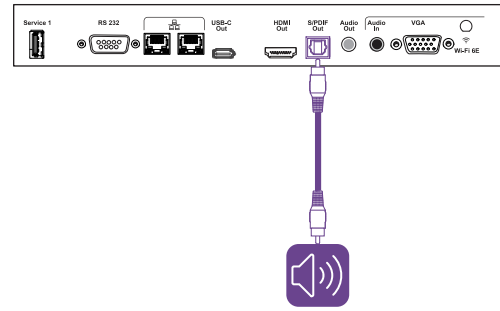

Note

The S/PDIF audio is a fixed-volume output. Adjusting the volume of the display's speakers does not affect the S/PDIF output.

If you have an external audio system with HDMI ARC (Audio Return Channel) or eARC (Enhanced Audio Return Channel), you can output the display's audio to the audio system by connecting the display's HDMI 2 In connector on the side connector panel to the HDMI Out connector on the audio system's receiver.

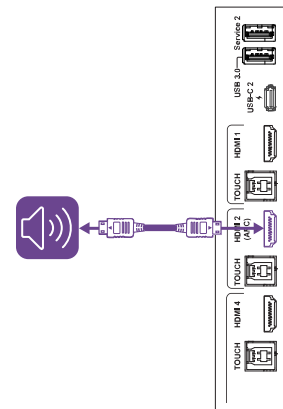

Connecting room control systems

A room control system enables users to control a room's lighting, audio system, and possibly, the display. Some installations may require you to integrate the display with a room control system.

You can use the display's RS-232 connector to connect a third-party external control system to the display.

Note

Displays are not compatible with centralized remote control systems, such as a universal remote control.

Connector diagrams

Side and bottom connector panels

This diagram and table present the connectors on the display's side and bottom connector panels:

Side

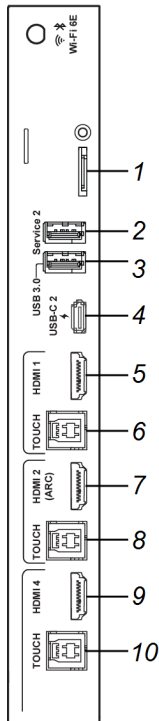

Bottom

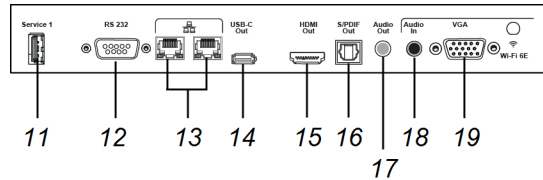

No.	Connector	Connects to	Notes
1	microSD	microSD card	This connector features a security cover to prevent theft of an installed microSD card.
2	USB 3.2 Gen 1 Type-A	N/A	This connector is a service port.
3	USB 3.2 Gen 1 Type-A	Supported USB drives, peripherals, and other devices	See > Page 23
4	USB Type-C	USB Type-C 2 input	See > Page 16 See > Page 23
5	HDMI 2.1 In	HDMI 1 input (video and audio)	See > Page 16 See > Page 25
6	USB 3.2 Gen 1 Type-B	HDMI 1 input (touch)	See > Page 16

No.	Connector	Connects to	Notes
7	HDMI 2.1 In	HDMI 2 input (video and audio)	This connector supports HDMI ARC (Audio Return Channel) and eARC (Enhanced Audio Return Channel), which allow audio signals to travel between the display and the connected device and improve audio quality as a result. See > Page 16 See > Page 25
8	USB 3.2 Gen 1 Type-B	HDMI 2 input (touch)	See > Page 16
9	HDMI 2.1 In	HDMI 4 input (video and audio)	See > Page 16 See > Page 25
10	USB 3.2 Gen 1 Type-B	HDMI 4 input (touch) OR VGA input (touch)	If you have devices connected to both the HDMI 4 and VGA inputs' connectors, you will need to share a USB cable connection between the devices (assuming you want touch on both devices). See > Page 16
11	USB 2.0 Type-A	N/A	This connector is a service port.
12	RS-232	Room control system	See > Page 31
13	RJ45 (×2)	Network	See > Page 11
14	USB Type-C	External display	See > Page 24
15	HDMI 2.1 Out	External display	See > Page 24
16	S/PDIF out	Digital audio output	See > Page 25
17	Stereo 3.5 mm Out	External audio system	See > Page 25
18	Stereo 3.5 mm In	VGA input (audio)	See > Page 16
19	VGA In	VGA input (video)	See > Page 16

Front connector panel

This diagram and table present the connectors on the display's front connector panel:

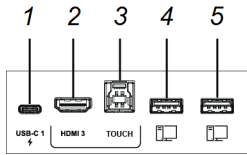

No.	Connector	Connects to	Notes
1	USB Type-C	USB Type-C 1 input	See > Page 16 See > Page 23
2	HDMI In	HDMI 3 input (video and audio)	See > Page 16 See > Page 25
3	USB 3.2 Gen 1 Type-B	HDMI 3 input (touch)	See > Page 16
4	USB 3.2 Gen 1 Type-A	Supported USB drives, peripherals, and other devices	See > Page 23
5	USB 3.2 Gen 1 Type-A	Supported USB drives, peripherals, and other devices	See > Page 23

Chapter 4 Troubleshooting

Troubleshooting the display and related SMART products

The Support section of the SMART website includes information about resolving a variety of common problems with the display and related SMART products.

See > support.smarttech.com/docs/mprot Troubleshooting

Contacting your reseller for additional support

If an issue you're experiencing with the display persists or isn't covered in the support section of the SMART website, contact your authorized SMART reseller (smarttech.com/where) for support.

Your reseller might ask you for the display's serial number.

The serial number is on a label located on the left side of the display.

Tip

Scan the QR code on the label to view the SMART Board M Pro series interactive display support pages on the SMART website.

Appendix A Managing the display using RS-232

Configuring the serial interface settings	31
Commands and responses	33
Power state commands	35
Input commands	35
Brightness commands	35
Freeze commands	36
Screen shade commands	36
Speaker commands	36
Firmware version commands	36
Model number commands	37
Serial number commands	37
Part number commands	37
Asynchronous messages	37

You can connect an RS-232 cable from a computer or a control system's serial output to the display's RS-232 In connector to remotely select video inputs, turn the display on or off, and get information about the display's current settings, such as volume and power state.

Important

Use only a standard RS-232 cable. Do not use a null modem cable. Null modem cables typically have ends of the same type.

Configuring the serial interface settings

Configure the computer or control system's serial interface before sending commands to the display.

1. Turn on the display.
2. If you're using a terminal application on a computer, activate local echo to see what you're typing and sending to the display.

- Configure the serial interface settings with the following values:

Baud rate	19200
Data length	8
Parity bit	None
Stop bit	1

- Send a carriage return character (<CR>) to the display. The display will show a command prompt (>) to indicate that the display can now accept commands.

Note

- If you're using a terminal application on a computer, pressing ENTER should send a carriage return character (<CR>) but may also send a line feed character (<LF>), depending on your terminal application configuration.
- If no message appears or an error message appears, the serial interface isn't configured correctly. Repeat steps 3 and 4.

When you use a control system program instead of terminal program, all lines output from the display are preceded by a carriage return character (<CR>) and line feed character (<LF>) and then followed by a carriage return character (<CR>) and line feed character (<LF>), as shown in the example below.

```
>set volume=0<CR>  
<CR><LF>  
volume=0<CR><LF>  
>
```

See also > wikipedia.org/wiki/ASCII

Commands and responses

To access display information or to adjust display settings using the room control system, send a command after the command prompt (>), send a carriage return character or press ENTER, and then wait for the response from the display. Responses are preceded by a carriage return character (<CR>) and line feed character (<LF>) and then followed by a carriage return character (<CR>) and line feed character (<LF>). If no command prompt is present, send a carriage return character to the display. If the display is ready to receive commands, it will show a command prompt (>) when the carriage return is received. See the example below.

Correct

```
>get volume  
volume=55  
>
```

Notes

- Use ASCII formatted commands.
- Commands aren't case-sensitive and extra spacing is ignored.
- Review each entry carefully before sending a command to the display.
- Don't send another command until you receive the response and the next command prompt (>). If no command prompt is present, send a carriage return character (<CR>) to the display. If the display is ready to receive commands, it will show a command prompt after receiving the carriage return.

To retrieve a setting's current value

Use a `get` command.

This example shows how to get the volume:

```
>get volume  
volume=55  
>
```

To assign a value to a setting

Use a `set` command.

This example sets the volume to 65:

```
>set volume=65  
volume=65  
>
```

To increase or decrease the value of a setting

Use the `set` command to increase or decrease the value by a designated number.

This example increases the volume by 5:

```
>set volume+5  
volume=70  
>
```

This example decreases the volume by 15:

```
>set volume-15  
volume=55  
>
```

To view information on all available commands¹

Use the `help` command.

```
>help
```

¹Including commands not in this appendix

Power state commands

Get command	Set command	Response
get powerstate	set powerstate[Value] Where [Value] is one of the following: <ul style="list-style-type: none"> • =on • =standby • =off 	powerstate=[Value] Where [Value] is one of the following: <ul style="list-style-type: none"> • on • standby • off

See also > support.smarttech.com/docs/energysavingmodes

Input commands

Get command	Set command	Response
get input	set input[Value] Where [Value] is one of the following: <ul style="list-style-type: none"> • =hdmi1 • =hdmi2 • =hdmi3 • =hdmi4 • =vga1 • =ops1 • =usbc1 • =usbc2 • =android 	input=[Value] Where [Value] is one of the following: <ul style="list-style-type: none"> • hdmi1 • hdmi2 • hdmi3 • hdmi4 • vga1 • ops1 • usbc1 • usbc2 • android

Brightness commands

Get command	Set command	Response
get brightness	set brightness[Value] Where [Value] is one of the following: <ul style="list-style-type: none"> • +[Value] • -[Value] • =[0-100] 	brightness=[Value] Where [Value] is a number between 0 and 100

Freeze commands

Get command	Set command	Response
get videofreeze	set videofreeze[Value] Where [Value] is one of the following: <ul style="list-style-type: none"> • =on • =off 	videofreeze=[Value] Where [Value] is one of the following: <ul style="list-style-type: none"> • on • off

Screen shade commands

Get command	Set command	Response
get screenshade	set screenshade[Value] Where [Value] is one of the following: <ul style="list-style-type: none"> • =on • =off 	screenshade=[Value] Where [Value] is one of the following: <ul style="list-style-type: none"> • on • off

Speaker commands

Get command	Set command	Response
get volume	set volume[Value] Where [Value] is one of the following: <ul style="list-style-type: none"> • +[Value] • -[Value] • =[0-100] 	volume=[Value] Where [Value] is a number between 0 and 100
get mute	set mute[Value] Where [Value] is one of the following: <ul style="list-style-type: none"> • =on • =off 	mute=[Value] Where [Value] is one of the following: <ul style="list-style-type: none"> • on • off

Firmware version commands

Get command	Response
get fwversion	fwversion=[Value] Where [Value] is the firmware version.

Model number commands

Get command	Response
get modelnum	modelnum=[Value] Where [Value] is one of the following: <ul style="list-style-type: none"> • SBID-MX055-V5 • SBID-MX065-V5 • SBID-MX075-V5 • SBID-MX086-V5

Serial number commands

Get command	Response
get serialnum	serialnum=[Value] Where [Value] is the serial number.

Part number commands

Get command	Response
get partnum	partnum=[Value] Where [Value] is the part number, including the revision.

Asynchronous messages

The display sends an asynchronous message when the front control panel, Settings app, or remote control are used to change a display's setting that can be controlled by RS-232. The display will also send an asynchronous message if the display's power state changes. Asynchronous messages are identified by a pound sign (#) before the message and aren't followed by a command prompt (>).

Change	Asynchronous message
Display power state	#powerstate=[Value] Where [Value] is one of the following: <ul style="list-style-type: none"> • on • standby • off

Change	Asynchronous message
Input selection	<p>#input=[Value] Where [Value] is one of the following:</p> <ul style="list-style-type: none"> • hdmi1 • hdmi2 • hdmi3 • hdmi4 • vga1 • ops1 • usbc1 • usbc2 • android
Brightness	<p>#brightness=[Value] Where [Value] is a number between 0 and 100</p>
Freeze frame	<p>#videofreeze=[Value] Where [Value] is one of the following:</p> <ul style="list-style-type: none"> • on • off
Screen shade	<p>#screenshade=[Value] Where [Value] is one of the following:</p> <ul style="list-style-type: none"> • on • off
Volume increase or decrease	<p>#volume=[Value] Where [Value] is a number between 0 and 100</p>
Volume mute	<p>#mute=[Value] Where [Value] is one of the following:</p> <ul style="list-style-type: none"> • on • off

Appendix B Enrolling the display in SMART Remote Management

SMART Board M Pro series interactive displays with iQ have a built-in feature that enables you to enroll the displays with your organization's SMART Remote Management account. When you enroll a display, you can use SMART Remote Management to centrally control the display's features and settings, such as:

- blocklists and allowlists
- Wi-Fi
- wallpaper
- certificates
- lock screen
- available apps

See > support.smarttech.com/docs/enrollingsrm

Certification and compliance

Electronic (e-label) information

Regulatory information is available in the display's settings. From the Home screen, tap **Settings > About > Regulatory Information**.

Informations électroniques (e-Label)

Les informations réglementaires sont disponibles dans les paramètres de l'écran. Depuis l'écran d'accueil, appuyez sur **Paramètres > À propos de > Informations réglementaires**.

Federal Communication Commission interference statement

FCC

Suppliers Declaration of Conformity

47 CFR § 2.1077 Compliance Information

Unique Identifier: IDX55-5, IDX65-5, IDX75-5, IDX86-5

Responsible Party – U.S. Contact Information

SMART Technologies Inc.

2401 4th Ave., 3rd Floor

Seattle, WA 98121

compliance@smarttech.com

This device complies with Part 15 of the FCC Rules. Operation is subject to the following two conditions:

1. This device may not cause harmful interference, and
2. this device must accept any interference received, including interference that may cause undesired operation.

Note

This equipment has been tested and found to comply with the limits for a Class A digital device, pursuant to part 15 of the FCC Rules. These limits are designed to provide reasonable protection against harmful interference when the equipment is operated in a commercial environment. This equipment generates, uses, and can radiate radio frequency energy and, if not installed and used in accordance with the instruction manual, may cause harmful interference to radio communications. Operation of this equipment in a residential area is likely to cause harmful interference in which case the user will be required to correct the interference at his own expense.

⚠ Caution

Any changes or modifications not expressly approved by the party responsible for compliance could void the user's authority to operate this equipment.

Restriction

Operations in the 5150–5250 MHz and 5925–6425 MHz bands are restricted to indoor usage only.

IEEE 802.11b or 802.11g operation of this product in the USA is firmware limited to channels 1 through 11.

⚠ Caution

- i. the device for operation in the band 5150–5250 MHz is only for indoor use to reduce the potential for harmful interference to co-channel mobile satellite systems;
- ii. the maximum antenna gain permitted for devices in the bands 5250–5350 MHz and 5470–5725 MHz shall comply with the e.i.r.p. limit; and
- iii. the maximum antenna gain permitted for devices in the band 5725–5825 MHz shall comply with the e.i.r.p. limits specified for point-to-point and non point-to-point operation as appropriate.
- iv. Users should also be advised that high-power radars are allocated as primary users (i.e., priority users) of the bands 5250–5350 MHz and 5650–5850 MHz and that these radars could cause interference and/or damage to LE-LAN devices.

Operation in the 5925–7125 MHz band shall be limited to indoor use only.

Operation on oil platforms, automobiles, trains, maritime vessels, and aircraft shall be prohibited except for on large aircraft flying above 3048 m (10,000 ft).

Devices shall not be used for control of or communications with unmanned aircraft systems.

Radiation exposure statement

This equipment complies with FCC radiation exposure limits set forth for an uncontrolled environment. This equipment should be installed and operated with minimum distance of 20 cm between the antenna of this device and all nearby persons. This transmitter must not be co-located or operated in conjunction with any other antenna or transmitter.

Innovation, Science and Economic Development Canada statement

This device complies with RSS-247 and RS-248 of the Innovation, Science and Economic Development Canada Rules. Operation is subject to the following two conditions:

1. This device may not cause harmful interference, and
2. this device must accept any interference received, including interference that may cause undesired operation.

Radiation exposure statement

This equipment complies with ISED radiation exposure limits set forth for an uncontrolled environment. This equipment should be installed and operated with minimum distance of 20 cm between the antenna of this device and all nearby persons. This transmitter must not be co-located or operated in conjunction with any other antenna or transmitter.

Innovation, Science et Développement économique Déclaration du Canada

Cet appareil est conforme à la norme ISED CNR-247 et CNR-248 pour les appareils radio agréés. Son fonctionnement est soumis aux deux conditions suivantes:

1. le dispositif ne doit pas produire de brouillage préjudiciable, et
2. ce dispositif doit accepter tout brouillage reçu, y compris un brouillage susceptible de provoquer un fonctionnement indésirable.

⚠ Advertissement

- i. les dispositifs fonctionnant dans la bande 5 150-5 250 MHz sont réservés uniquement pour une utilisation à l'intérieur afin de réduire les risques de brouillage préjudiciable aux systèmes de satellites mobiles utilisant les mêmes canaux;
- ii. le gain maximal d'antenne permis pour les dispositifs utilisant les bandes 5 250-5 350 MHz et 5 470-5 725 MHz doit se conformer à la limite de p.i.r.e.;
- iii. le gain maximal d'antenne permis (pour les dispositifs utilisant la bande 5 725-5 825 MHz) doit se conformer à la limite de p.i.r.e. spécifiée pour l'exploitation point à point et non point à point, selon le cas.
- iv. De plus, les utilisateurs devraient aussi être avisés que les utilisateurs de radars de haute puissance sont désignés utilisateurs principaux (c.-à-d., qu'ils ont la priorité) pour les bandes 5 250-5 350 MHz et 5 650-5 850 MHz et que ces radars pourraient causer du brouillage et/ou des dommages aux dispositifs LAN-EL.

Les opérations dans la bande 5925-7125 MHz doivent être limitées à une utilisation en intérieur.

L'utilisation sur les plates-formes énergétiques, les autos, les train, les vaisseaux navigateurs et les avions sera interdite, sauf sur les gros appareils volant au-dessus de 3 048 m (10 000 pieds).

Ces appareils ne doivent pas être utilisés pour contrôler des systèmes de navigation sans pilote ou pour communiquer avec eux.

Déclaration d'exposition aux radiations

Cet équipement est conforme aux limites d'exposition aux rayonnements ISED établies pour un environnement non contrôlé. Cet équipement doit être installé et utilisé avec un minimum de 20 cm de distance entre la source de rayonnement et votre corps. Cet émetteur ne doit pas être co-implantés ou exploités conjointement avec une autre antenne ou émetteur.

EU declaration of conformity

Hereby SMART Technologies ULC declares that the radio equipment type Interactive displays model IDX55-5, IDX65-5, IDX75-5, IDX86-5, and the OPS PCM11 are in compliance with Directive 2014/53/EU.

⚠ Warning

Operation of this equipment in a residential environment this equipment may cause radio interference.

The full text of the EU declaration of conformity is available at the following internet address: smarttech.com/compliance

The frequency band and the maximum transmitted power in EU are listed below:

Restrictions in

AT/BE/BG/CZ/DK/EE/FR/DE/IS/IE/IT/EL/ES/CY/LV/LI/LT/LU/HU/MTNL/NO/PL/PT/RO/SI/SK/TR/FI/SE/CH/UK/HR—5150MHz-5350MHz and 5925MHz-6425MHz are for indoor use only.

⚠ Caution: Exposure to Radio Frequency Radiation

This equipment complies with EU radiation exposure limits set forth for an uncontrolled environment. This equipment should be installed and operated with minimum distance 20 cm between the radiator and your body.

Hardware environmental compliance

SMART Technologies supports global efforts to ensure that electronic equipment is manufactured, sold, and disposed of in a safe and environmentally friendly manner.

Certification and compliance

Waste Electrical and Electronic Equipment and Battery regulations (WEEE and Battery Directives)

Electrical and electronic equipment and batteries contain substances that can be harmful to the environment and to human health. The crossed-out wheeled bin symbol indicates that products should be disposed of in the appropriate recycling stream and not as regular waste.



Batteries

Caution

There is a risk of fire or explosion if a battery is replaced by an incorrect type. Dispose of used batteries promptly. Follow handling instructions on coin cell packaging. Recycle or dispose of used batteries according to local guidelines.

The display contains a CR1220 battery coin cell battery. The remote control contains alkaline batteries. Recycle or dispose of batteries properly.

Perchlorate material

The coin cell battery contains perchlorate material. Special handling may apply.

See > dtsc.ca.gov/hazardouswaste/perchlorate

SMART Technologies

smarttech.com/support

smarttech.com/contactsupport

docs.smarttech.com/kb/171980