

# EdgeReady™ Micro Data Center

Premium Rack, 34U Usable, 6 kVA (N+N), 208/240V or 230V



## Benefits

- Provides preconfigured IT infrastructure for edge computing servers, storage and network hardware in your most critical applications
- Integrates secure rack space, reliable power distribution, expandable battery backup, remote management and optional cooling
- Prevents configuration errors, reduces installation time, decreases field costs and standardizes edge computing infrastructure
- Ships three business days from receipt of order, after design, assembly and testing by experts in a controlled environment

## Included Hardware

- A** **SR42UB** Premium Rack Enclosure (Standard Width/Depth)
- B** (2) **SU6000RT4UHV**G SmartOnline® UPS Systems with (2) **WEBCARDLX** Network Management Cards
- C** **E2MTHDI** Environmental Sensor (Temperature/Humidity/Digital Inputs)
- D** (2) **PDU**MV20HV Metered PDUs with (2) **P036-006** Input Cords

Assembled/tested unit also includes reinforced shock pallet and loading ramps for stable shipment and re-shipment with installed IT equipment.

See Next Page for Customization Options

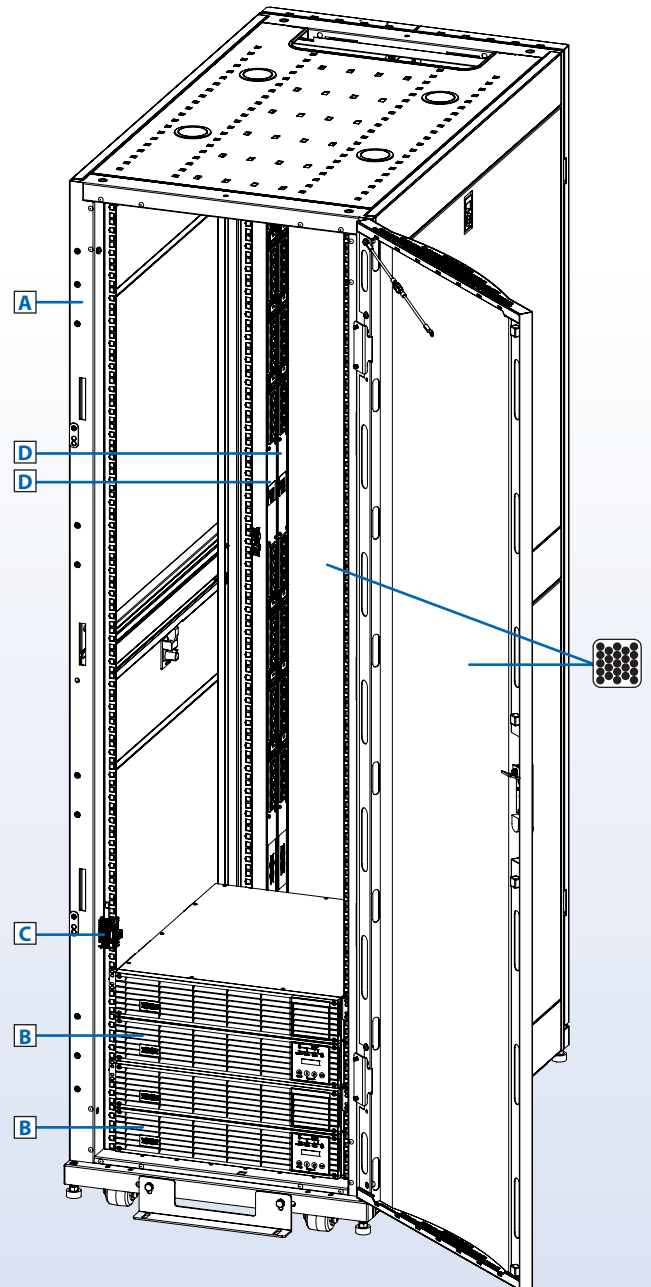

## Specifications

<b>Model (Kit)</b>	<b>MDK3F34UPX00000</b>
<b>Model (Assembled/Tested)</b>	<b>MDA3F34UPX00000</b>
Output Power Capacity	(2) 6 kVA/5.4 kW/26A Max (208V) (N+N Redundancy)
Rack Space	42U Total; 34U Usable
Weight Capacity	3000 lb. (1360 kg) Total; 2462 lb. (1116 kg) Usable
Maximum Device Depth	37 in. (940 mm)
Site Power Requirements	(2) 208/240V, 30A or 230V, 32A, 50/60 Hz (2 Separate Circuits)
Site Outlet Required	(2) Hardwire (208/240V 30A L1-L2-G or 230V 32A L-N-G)
UPS Type	On-Line with Pure Sine Wave Output and Zero Transfer Time
Runtime (50%/100% Load)	8.5/2 min. (Expandable)
High-Availability Features	N+N Redundancy; On-Line (VFI) Operation; Auto Bypass; Battery Backup; Hot-Swappable Batteries; Hot-Swappable Power Modules
Usable Outlets (UPS + PDU)	(64) C13, (18) C19
Dimensions (Assembled)	78.5 x 23.63 x 43 in. (1994 x 600 x 1092 mm)
Weight (Assembled)	538 lb. (244 kg)
Warranty*	2-Year Limited Warranty (Extendable)

\*Any component with a warranty longer than 2 years will be covered by the longer warranty.



Powering and Connecting Your World

# Unlimited Micro Data Center Customization

Tripp Lite's solutions team is standing by to help you tailor your EdgeReady™ micro data center to match the business and technology requirements of your edge deployment strategy. We ship custom solutions in as little as five business days, assembled and tested. We can help you customize your EdgeReady™ micro data center in several ways:

- Quick and easy customization via stocked add-on accessories for the base configurations
- Upgrades to included components of base configurations with stocked alternatives
- Customization of individual components like racks, PDUs and cables (increases lead time)

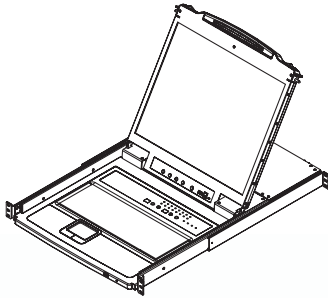

**B020-U16-19-IP**

1U Rack Console with 16-Port KVM Switch and Remote Access

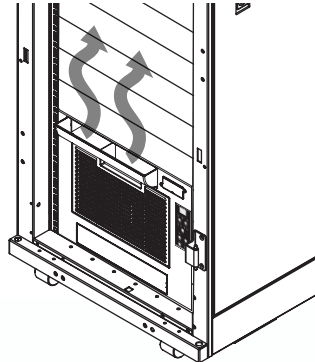

**SRCOOL7KRM**

8U Rack-Mount Air Conditioning Unit (2 kW)

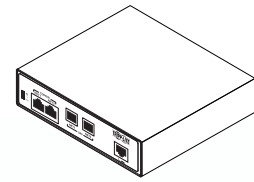

**B093-008-2E4U-M**

8-Port Console Server with Built-in Modem for Fail-Safe Access



**PDUMV20HVNETLX**

Vertical Switched PDU with Remote Current Monitoring, Alerts and Outlet Control

## Optional Accessories, Sold Separately (Visit [www.tripplite.com](http://www.tripplite.com) to see the full selection.)

Switched PDUs	(2) <b>PDUMV20HVNETLX</b> with (40) C13, (8) C19; 0U (Replace standard PDUs.)
Battery Packs for Extended Runtime (50%/100% Load)	22/8.5 min. with (2) <b>BP192V5RT2U</b> (Limit 1 per UPS); 42/17 min. with (2) <b>BP192V12-3U</b>
Cooling	<b>SRCOOL7KRM</b> (2 kW; 8U Rack-Mount, NEMA 5-15P) or <b>SRCOOL12K</b> (3.5 kW; Portable; NEMA 5-15P)
KVM Switch	<b>B022-U16-IP</b> ; <b>B020-U16-19-IP</b> (With LCD Console)
Console Server	<b>B093-008-2E4U-M</b>
Door Monitoring Kit	<b>SRSWITCH</b> (Monitors Front/Rear Doors)
Airflow Management	<b>SR1UPANEL10</b> and/or <b>SR1UBRUSH</b>
Cable Managers	40+ Horizontal, Vertical and External Cable Management Options at <a href="http://tripplite.com">tripplite.com</a>
Power Cords	Match to IT Equipment; 250+ Power Cord Options at <a href="http://tripplite.com">tripplite.com</a>
Network Cables	Match to IT Equipment; 1,000+ Copper and Fiber Network Cable Options at <a href="http://tripplite.com">tripplite.com</a>
Patch Panels	60+ Copper and Fiber Patch Panel Options at <a href="http://tripplite.com">tripplite.com</a>
Additional Sensors	<b>E2MT</b> (Up to 3 Sensors Total per WEBCARDLX to Monitor Top/Middle/Bottom Temperature)

1111 W. 35th Street, Chicago, IL 60609 USA | 773.869.1236 | [www.tripplite.com](http://www.tripplite.com)



Powering and Connecting Your World