



Epson[®] SureLab[®] D800 Series Operation Guide

Copyrights and Trademarks

Copyrights and Trademarks

EPSON®, SureLab®, and UltraChrome® are registered trademarks, and EPSON Exceed Your Vision is a registered logomark of Seiko Epson Corporation.

Epson PreferredSM and Epson StoreSM are service marks of Epson America, Inc.

Apple, Mac, OS X, and macOS are trademarks of Apple Inc., registered in the U.S. and other countries.

Windows is a registered trademark of Microsoft Corporation in the United States and/or other countries.

General Notice: Other product names used herein are for identification purposes only and may be trademarks of their respective owners. Epson disclaims any and all rights in those marks.

© 2019 Epson America, Inc.

6/19

CPD-57420

Contents

Introduction

Meaning of Symbols.	5
Screen Shots in the Guide.	5
Printer Parts.	6
Front.	6
Rear.	9
PaperFeed.	10
Print head	11
Roll Paper Spindle.	11
Lights.	12
Safety Instructions.	14
Meaning of Symbols and Marks.	14
Notes on Installation.	15
Notes on Handling.	15
Notes on the Power Supply.	17
Notes on Consumables.	18
Other Notes.	18
Notes on Usage.	19
Notes when Handling the Main Unit.	19
Notes on the Paper.	19
Notes on Ink Cartridges.	21
Disposing of Used Ink Cartridges and Maintenance Tanks.	22
Introducing the Software.	22

Printing Methods

Basic Printing Methods.	23
---------------------------------	----

Replacing Paper

How to replace.	25
Preparing to Replace Paper.	25
Recording the Remaining Paper Level.	27
Removing the Roll Paper Spindle from the Printer 29	
Removing the Roll Paper from the Spindle.	31
Placing Roll Paper on the Spindle.	32
Inserting the Roll Paper Spindle.	33
Changing Paper Settings.	38

Paper Output

Print tray (optional).	42
Large Print Tray (optional).	43

Attaching the Print Tray (Optional)	44
Attaching the Large Print Tray Optional.	46

Replacing Ink Cartridges

Checking Ink Levels.	48
Checking from the Printer.	48
Checking from the Computer.	49
Replacing the Ink.	52

Replacing the Maintenance Tank

Checking the Free Space in the Maintenance Tank.	56
Checking from the Printer.	56
Checking from the Computer.	57
Replacement Procedure.	59

Emptying the Scrap Paper Box

Cleaning the Platen

Maintenance

Maintenance Tool.	66
Regular Maintenance.	67
Scrap paper box.	67
Vacuuuming the Airflow Vents.	67

Troubleshooting

When an Error Occurs.	68
Light Status.	68
Error Messages (Windows).	71
Error Messages (Mac).	71
Errors and Solutions (Windows).	72
Errors and Solutions (Mac).	77
Cannot Clear the Displayed Error.	82
Paper Jams.	84
Deleting Print Jobs.	85
Paper is Jammed in the Roll Paper Feeder.	86
Paper is Jammed Inside the Printer.	92
Problems with Print Results.	98
Problems when Cutting Paper.	99

Contents

When a Problem Cannot be Cleared. 99

Appendix

Consumables and Optional Items. 100

Notes on Moving the Printer. 101

 Preparing to Move. 102

 After Moving. 102

Printer Specifications. 103

 Standards and Approvals. 104

 Necessary space. 105

Notes. 106

 FCC Compliance Statement. 106

 For European customers only. 106

Where To Get Help



Internet Support 108

Speak to a Support Representative. 108

Purchase Supplies and Accessories 108

Introduction

Meaning of Symbols

 Warning:	Warnings must be followed to avoid serious bodily injury.
 Caution:	Cautions must be followed to avoid damage to this product or bodily injury.
 Important:	Important must be followed to avoid damage to this product.
Note:	Notes contain important information on the operation of this product.

Screen Shots In the Guide

- Screen shots used in this manual may differ to the actual screens. Also, the screens may differ depending on the operating system used and the usage environment.
- Unless otherwise noted, screen shots in this manual are from Windows 7 and Mac OS X 10.7.

Printer Parts

Front

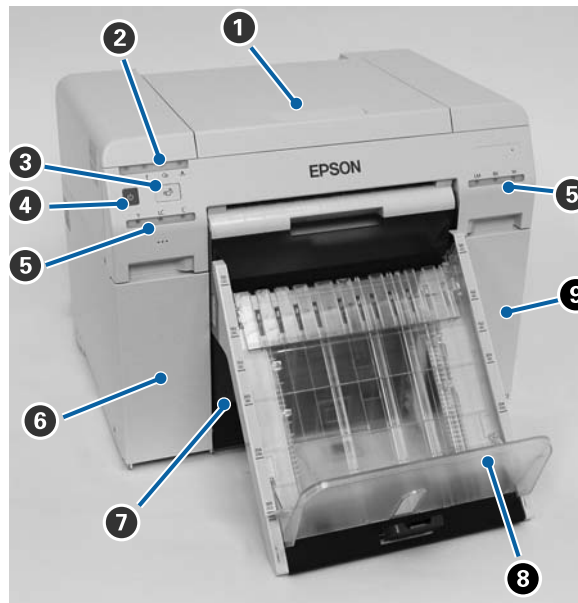

1 Top cover

Open when a paper jam occurs or to perform maintenance.

2 Status display light

This light indicates when the printer's status is normal or if an error has occurred.

[See "Lights" on page 12](#)

3  button

Press to replace the roll paper. The roll paper is wound back to the replacement position.

[See "Replacing Paper" on page 25](#)

4 Power button

5 Ink light (orange)

[See "Lights" on page 12](#)

6 Cartridge cover (left)

Open when replacing ink cartridges.

[See "Replacing Ink Cartridges" on page 48](#)

Before Use

7 Scrap paper box

Holds waste paper that is cut off during printing. Empty the scrap paper box when you replace the paper. Needs to be removed when loading or removing paper.

See “Emptying the Scrap Paper Box” on page 61

8 Print tray (optional)/Large print tray (optional)

Holds the ejected print outs.

See “Attaching and Removing the Print Tray (Optional)” on page 44

See “Attaching and Removing the Large Print Tray (Optional)” on page 46

9 Cartridge cover (right)

Open when replacing ink cartridges or the maintenance tank.

See “Replacing Ink Cartridges” on page 48

See “Replacing the Maintenance Tank” on page 56

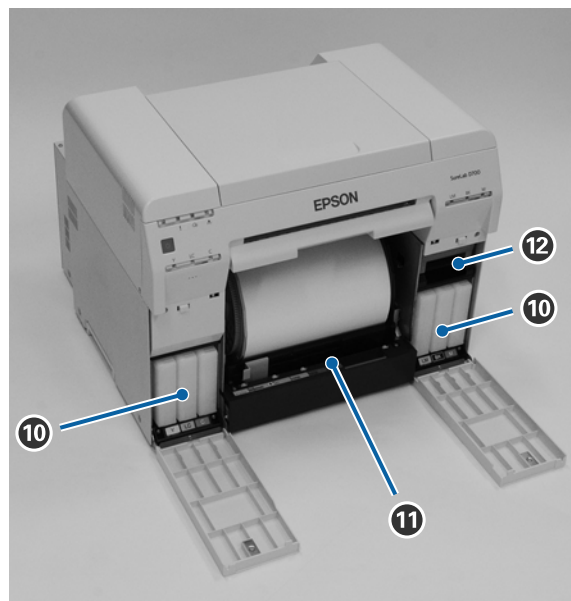

10 Ink cartridges

11 Roll paper feeder

Pull this to the front when removing the roll paper spindle.

Before Use

⑫ Maintenance Tank

Container that holds waste ink.

See “Replacing the Maintenance Tank” on page 56

Rear

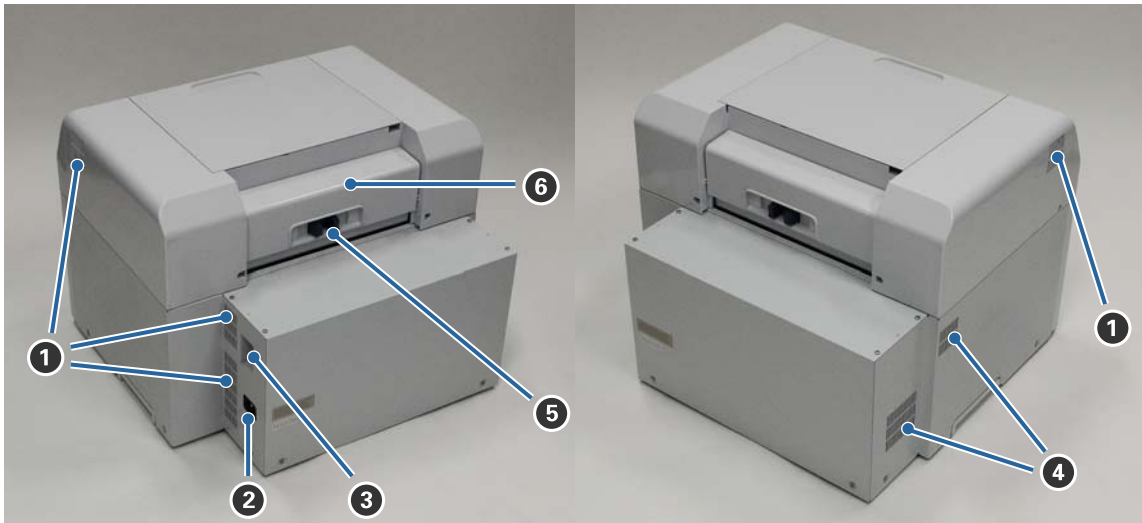

- 1 Exhaust vent**
Exhausts air used to cool the printer internally.

- 2 AC inlet**

- 3 USB port**

- 4 Airflow vent**
Takes in air to cool the printer internally.

- 5 Lock lever**
Releases the lock for the rear cover.

- 6 Rear cover**
Open when a paper jam occurs or to perform maintenance.

Paper Feed

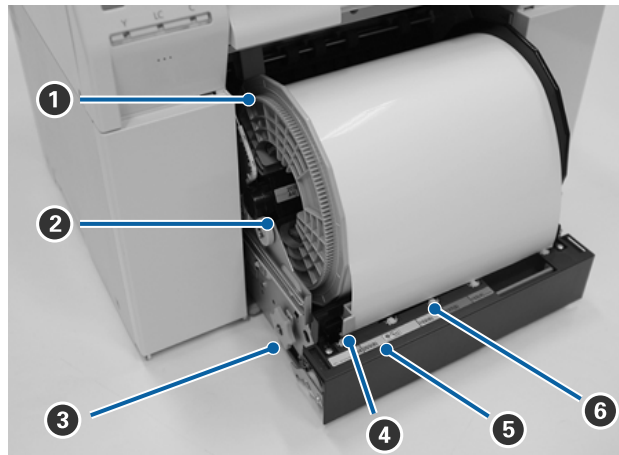

- 1 Inner edge guide**
Set this to the width of the roll paper.

- 2 Roll paper spindle**
Holds the roll paper.

- 3 Knob**
Turn this to rewind the roll paper onto the roll paper spindle.

- 4 Front edge guide**
Set this to the width of the paper.

- 5 Paper light (blue)**
Indicates the paper insertion status for the roll paper feeder.

On: Paper is loaded correctly.
Off: Paper is not been loaded.

- 6 Paper slot**
Insert the leading edge of the roll paper here.

Print head

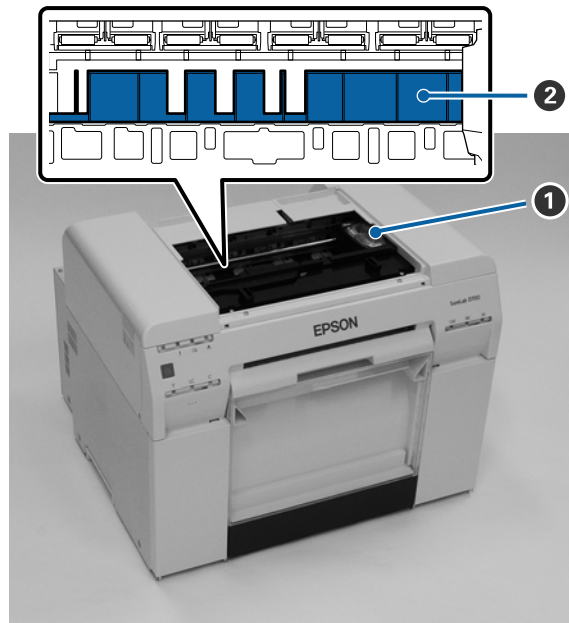

1 Print head

Do not touch the print head unless you are removing a paper jam. Manually moving the print head may damage the printer.

2 Platen

Clean the platen if the back of the printed paper is dirty.

See [“Cleaning the Platen” on page 63](#)

Roll paper spindle

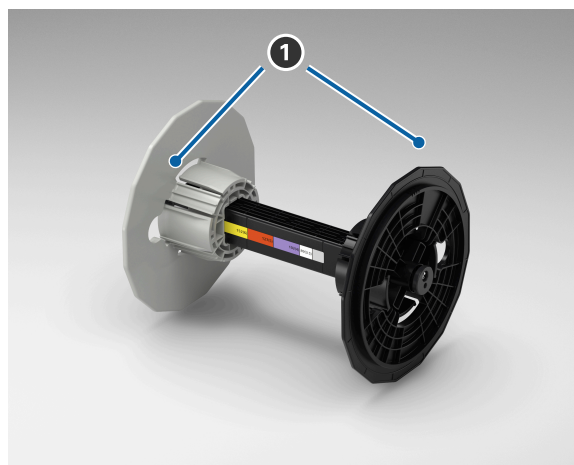

1 Adapter

Insert into the ends of the roll paper's roll core on the left and right to secure it.

Lights

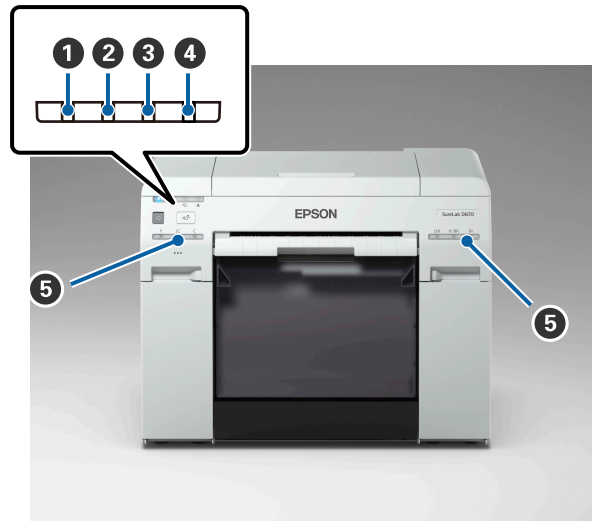

① light (blue)

Indicates the printer's operational status:

On: The printer is ready to print.

Flashing: The printer is printing, initializing, performing maintenance, etc.

Off: The printer is not on, or printer operations have stopped due to an error.

② light (orange)

Indicates the printer's error status:

On: An error has occurred, the printer is performing error recovery operations, or a printer system error has occurred.

Off: No error.

③ light (orange)

Indicates the status of the roll paper feeder:

On: Paper has not been loaded in the roll paper feeder, or the paper is out.

Flashing: A paper jam has occurred.

Off: No error.

Before Use

④ light (orange)

Indicates the status of the maintenance tank:

On: There is not enough free space in the maintenance tank, or an error has occurred because the maintenance tank was not recognized correctly.

[See “Replacing the Maintenance Tank” on page 56](#)

Off: No error.

⑤ Ink light (orange)

Indicates the status of the ink cartridges:

On: There is not enough ink in the ink cartridge, or the ink cartridge was not recognized correctly.

[See “Replacing Ink Cartridges” on page 48](#)

No error.

Off:

Safety Instructions

To use this printer safely, be sure to read the manual supplied with the printer before use. Not handling this printer as described in the supplied manual could cause a breakdown of the printer or an accident. To resolve any unclear points regarding the printer, keep this manual on hand at all times.

Meaning of Symbols and Marks

The symbols on this Epson product are used in order to ensure safety and proper use of the product and to prevent danger to customers and other persons, and property damage.

The symbols indicate the meaning below. Be sure that you completely understand the meaning of symbols on this product before using it.













Warning:

This symbol indicates information that, if ignored, could possibly result in serious injury or even death due to incorrect handling.



Caution:

This symbol indicates information that, if ignored, could possibly result in bodily injury or damage to property due to incorrect handling.

	Indicates that your hand could get trapped.		Indicates that the printer must not get wet.
	Indicates prohibited (do not do) actions.		Indicates items (instructions/operations) that must be performed.
	Indicates that disassembly is prohibited.		Indicates that the power plug must be unplugged.
	Indicates that you must not touch the printer with wet hands.		Indicates that the printer must be earthed.
	Indicates that specific parts must not be touched.		Stand-by
	Alternating Current		

Before Use

Notes on Installation

Warning



Do not block the printer's airflow vents.

If the airflow vents are blocked, the internal temperature rises and could cause a fire.

Do not cover with a cloth or other materials and do not install in an area with poor ventilation. Make sure to leave enough space around the printer. See the *Start Here* sheet for more information.

See ["Necessary space" on page 105](#)

Caution



Do not install or store the printer in a location that is unstable or subject to vibrations from other equipment. If the printer falls, an injury could occur.



Do not install the printer in smoky or dusty locations, humid locations, or locations where it is likely to get wet; Electric shock or fire could occur.



When lifting the printer, make sure you use correct lifting posture. If you do not use correct posture, an injury could occur.



If you place the printer on a stand with casters (wheels), make sure you secure the casters to prevent them from moving before starting operations.

If the stand moves unexpectedly during operations, an injury could occur.

Notes on Handling

Warning



Do not use in locations with volatile substances such as alcohol and thinner, or in locations with fires. Electric shock or fire could occur.



Do not use the printer if you notice smoke, strange odors, or sounds.

Electric shock or fire could occur.

If an abnormality occurs, turn off the printer immediately, unplug it from the electrical outlet, and contact your local dealer.









Do not use this printer if foreign materials, water, or other liquids have entered the printer.

Electric shock or fire could occur.







Turn off the printer immediately, unplug it from the electrical outlet, and contact your local dealer.

Before Use









⚠ Warning

	Except as instructed in the documentation, do not disassemble the printer.
	Making repairs yourself is extremely dangerous and must not be attempted.
	Do not use the printer in locations where flammable or explosive gas may be present in the atmosphere. Also, do not use sprays containing flammable gas inside or around this printer. A fire could ignite.
	Except as instructed in the documentation, do not perform any other wiring. A fire could ignite. Other connected equipment could also be damaged.
	Except as instructed in the documentation, do not touch any other parts inside this printer. Electric shock, burns, or injury could occur.
	Do not insert or drop any metallic or flammable objects into this printer through the openings. Electric shock or fire could occur.

⚠ Caution

	Do not climb on the printer and do not place any heavy objects on the printer. If it falls or breaks an injury could occur.
	When connecting cables or optional accessories, make sure they are installed in the correct direction and that you follow the procedures exactly. A fire or an injury could occur. Connect the cables or optional accessories correctly by following the instructions in the manual.
	When moving the printer, turn it off, unplug the power cable from the electrical outlet, and make sure that all cables have been disconnected. If cables are damaged, electric shock or fire could occur.
	Do not put your fingers near the paper roller section when the printer is on or when it is printing. If your fingers are caught in the paper roller, an injury could occur. Only handle the paper after it has been ejected completely.
	When storing or transporting this printer, do not tilt it, stand it on its side, or hold it upside down. Ink could leak out.
	When opening and closing the covers, do not place your hands near the points where the main unit and the cover join. If your fingers or hands are trapped, an injury could occur.
	When moving the roll paper feeder in or out, grip the handle. If you place your hands into any other sections, either side of your hand or fingers could be injured.

Notes on the Power Supply

 Warning	
	<p>Use only the type of the power supply indicated on the label. Electric shock or fire could occur.</p>
	<p>Do not use the power plug if any foreign materials such as dust are stuck to it. Electric shock or fire could occur.</p>
	<p>Make sure the power plug is fully inserted into the electrical outlet. Electric shock or fire could occur.</p>
	<p>Do not use the power cable if it is damaged. Electric shock or fire could occur.</p> <p>Contact your local dealer if the power cable is damaged. Note the following points to avoid damaging the power cable:</p> <ul style="list-style-type: none"> <input type="checkbox"/> Do not modify the power cable <input type="checkbox"/> Do not put heavy objects on the power cable <input type="checkbox"/> Do not bend, twist, or pull <input type="checkbox"/> Do not place it near heating appliances
	<p>Do not plug in or unplug the power cable with wet hands. Electric shock could occur.</p>
	<p>Do not perform daisy-chain wiring for the power cable. It could overheat and cause a fire. Take power directly from a residential electrical outlet.</p>
	<p>Unplug the power cable periodically and clean between the blades and the base of the blades. If the power cable is left plugged in for an extended period of time, dust could accumulate around the edge of the plug which could cause a short-circuit and a fire.</p>
	<p>When unplugging the power cable from the electrical outlet, grasp the plug itself and not the cable. The cable could be damaged or the plug could be deformed and an electric shock or fire could occur.</p>

Before Use

Caution



For safety reasons, when the printer is not used for an extended period of time, unplug the power cable from the electrical outlet.

Notes on Consumables

Caution



If ink gets in the eyes or mouth, or stains the skin, treat the area as follows:

- If ink adheres to your skin, immediately wash it off using soapy water.
- If ink enters your eyes, rinse immediately with water. Failure to observe this precaution could result in bloodshot eyes or mild inflammation. If you notice any abnormalities, consult a physician immediately.
- If ink enters your mouth, consult a physician immediately.



Do not disassemble ink cartridges and the maintenance tank. If it is disassembled, ink could get in your eyes or adhere to your skin.



Do not shake the ink cartridges too hard.
Ink may leak from the cartridge if you shake it too hard.



Do not store ink cartridges and the maintenance tank within the reach of children.

Other Notes

- Be sure your power cable meets relevant safety standards of the area where you plan to use it.
- Connect all equipment to properly grounded power outlets.
- Do not put your hand inside this product or touch the printer head during printing.
- Do not put your hand inside this product or touch the white flat cable during printing.

Notes on Usage

Notes when Handling the Main Unit

- Do not suddenly change the temperature in the room where this printer is installed. If the temperature changes suddenly, drops of water (condensation) could occur inside the printer which may have an adverse effect on operations.
- Use the printer in an environment with a temperature of 50 to 95°F (10 to 35°C), and a humidity of 20 to 80%. When the printer is placed on a system rack, make sure the environment of the rack is within these ranges.
- Do not place any containers containing water on the printer. If water enters the printer, it may damage the printer. Also, do not put any heavy objects on the printer.
- The printer is equipped with several airflow vents. The airflow vents allow air to go in and out of the printer. Do not block these airflow vents by placing any objects near them, or by covering them.
- Do not use accessories designed for this printer with any other products.
- If you open the printer's covers during printing, a safety device is activated and printing stops automatically. Do not turn off the printer in this condition. This could cause the print head nozzles to dry and print quality to decline.
- If the printer is not used for an extended period of time, make sure you leave the ink cartridges and maintenance tank installed.
- Contact Epson Service and Support for guidelines when transporting the printer.

Notes on the Paper

Notes on handling

Use paper recommended by Epson.

Note the following points when handling the paper:

- Do not bend the paper or scratch the surface of the printable side.
- Do not touch the printable side of the paper. Moisture and oil from hands can have an adverse effect on the print quality.
- Handle the paper by the edges.
- Do not throw away the paper packaging as you can use it for storing the paper.
- Do not wet the paper.

Before Use

- ❑ Do not use paper that is wrinkled, scuffed, torn, or dirty.
- ❑ If the printer is left with paper loaded for some time, the leading edge of the paper may curl and print quality may decline. Epson recommends removing paper from the printer when it is not in use.

Notes on storage

Before and after opening the paper, store it in an environment that is not subject to direct sunlight. If paper is not used after it has been opened, remove it from the roll paper spindle and wind it up before storing it in the original packaging.

Notes on printing

Make sure that the leading edge of the paper is perpendicular to the long side and cut completely straight.

Storing and displaying print outs

- Make sure you do not rub or scratch the printed side.
- Avoid locations that are subject to high temperature, humidity, and direct sunlight, and store in a dark place.
- Avoid displaying print outs outdoors or in direct sunlight. This may accelerate the fading.
- When displaying print outs, Epson recommends placing them in glass frames. This will minimize fading.

Notes on Ink Cartridges

- Ink yields vary considerably based on images printed, print settings, paper type, frequency of use and temperature. Cartridge Models: for print quality, a variable amount of ink remains in the cartridge after the "replace cartridge" indicator comes on.
- This printer is designed for use with Epson genuine cartridges and ink only, not third-party cartridges or ink.
- Epson periodically provides firmware updates to address issues of security, performance, minor bug fixes and ensure your printer functions as designed. Your printer was designed to work only with genuine Epson inks, therefore some updates may affect the functionality of third party ink.
- If you move the ink cartridges from a cold place to a warm place, leave them at room temperature for more than four hours before use.
- Ink cartridges should be stored in a cool location and used before the expiration date printed on the packaging. Ink cartridges should be used within six months of opening.
- Do not touch the ink supply port on the ink cartridge or its surrounding area. Ink may leak from it.
- The ink level and other data are stored in the IC chip, allowing ink cartridges to be used after being removed and replaced.
- To avoid getting dirt on the ink supply port, store the removed ink cartridge properly. The ink supply port has a valve in it and does not need to be capped or taped.
- Removed ink cartridges may have ink around the ink supply port, so be careful not to get any ink on the surrounding area when removing the cartridges.
- Do not touch the green section (IC chip) on the ink cartridge, otherwise you may not be able to print properly.
- Do not drop or knock ink cartridges against hard objects, otherwise the ink may leak.

Before Use

- ❑ Even while nothing is printed, the printer uses ink from all cartridges during head cleaning and other maintenance operations to keep the print head in good condition.
- ❑ Although the ink cartridges may contain recycled materials, this does not affect printer function or performance.
- ❑ Do not leave the printer without ink cartridges installed. The inks inside the printer may dry and you may not be able to print. When you are not using the printer, make sure there is an ink cartridge installed in each slot.
- ❑ Install ink cartridges into each slot. You cannot print if any of the slots are empty. To maintain the quality of the head, the printer stops printing before ink cartridges are completely expended. Some ink remains in used cartridges.
- ❑ Do not dismantle or remodel ink cartridges. You may not be able to print properly.

Disposing of Used Ink Cartridges and Maintenance Tanks

Dispose of consumables and optional parts in accordance with your local laws and statutes, such as by entrusting them to an industrial waste disposal company.

Introducing the Software

You need to install the printer driver on your computer to use the printer.

Software Name	Summary
Printer Driver	This software allows you to print using the printing instructions from another application. See "Printer Driver Operation Guide"
Maintenance Tool	This software allows you to perform adjustment and maintenance operations such as checking the printer's status, making settings, performing head cleaning. This is installed with the printer driver. See "Maintenance Tool Operation Guide"

Printing Methods

Basic Printing Methods

See the "Printer Driver Operation Guide" for more details on the printer driver.

- 1** Load paper into the printer.
[See "Replacing Paper" on page 25](#)
- 2** Display the print screen for the application you are using.
Click **Print** (or **Print...**) from the **File** menu.
Operations may differ depending on the application software being used. See the manual supplied with the application for more details.
- 3** Display the printer driver's screen from the application's print screen.
In Windows, select this printer, and then click **Print Settings** (or **Detailed Settings** or **Properties**).
On Mac, select this printer, and then select **Print Settings** from the list. You cannot select this from the macOS Sierra standard software.

Printing Methods

- 4 Select any of the settings as necessary.

Windows:

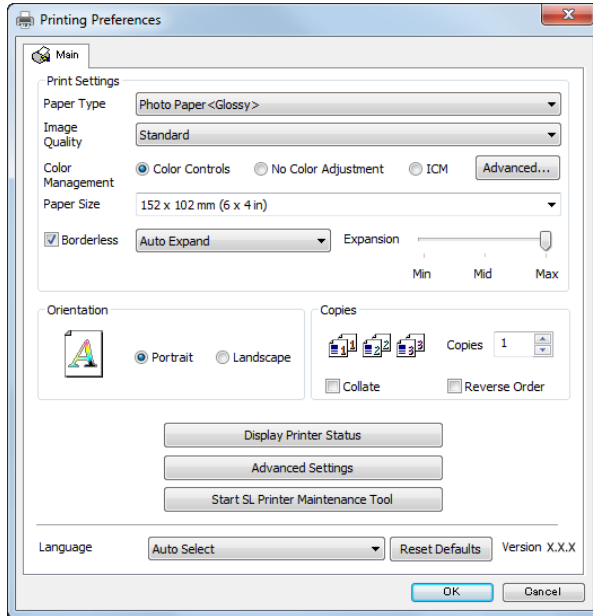

Mac:

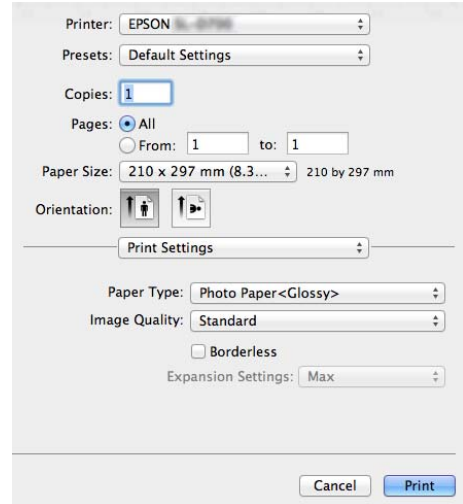

See the "Printer Driver Operation Guide" for an explanation of each setting item.

- 5 When you have finished, click **OK**.

- 6 On the application's print screen, click **Print** (or **Print...**) to start printing.

Replacing Paper

This section explains how to remove paper from the roll paper feeder and load new paper.

 **Important:**

Make sure the Paper Type setting in the Maintenance Tool matches the paper being loaded. Change the Paper Type setting immediately after replacing paper.

See “Changing Paper Settings” on page 38

Note:

- If the leading edge of the paper is ragged, cut it in a straight line with a pair of scissors and then load it.*
- See the following for supported paper types:
See “Printer Specifications” on page 103*
- The following conditions are necessary when replacing paper with the same paper width and type.*
 - Before replacing, note the current paper level.*
 - Set the paper level with the Maintenance Tool after replacement.*

If the Paper Level is not set correctly, the level displayed may not be correct.

See “Changing Paper Settings” on page 38

- You can load genuine Epson paper in 5", 6" and 8" roll widths in the roll paper feeder. The roll paper feeder supports roll paper between 3.5" and 8.3" wide.*

How to replace

Preparing to Replace Paper

Replace paper in the following order. Follow the steps for each procedure.

- See “Recording paper level” on page 27
- See “Removing the Roll Paper Spindle” on page 29
- See “Removing the Roll Paper” on page 31

Replacing Paper

- ❑ See “Attaching the Roll Paper” on page 32
- ❑ See “Attaching the Roll Paper Spindle” on page 33
- ❑ See “Changing Paper Settings” on page 38

Replacing Paper

Recording the Remaining Paper Level

If necessary, make a note of the paper level before replacing the paper.

Windows

- 1 Open the **Print Settings** menu.
See “Basic Printing Methods” on page 23
- 2 Click **Display Printer Status**.

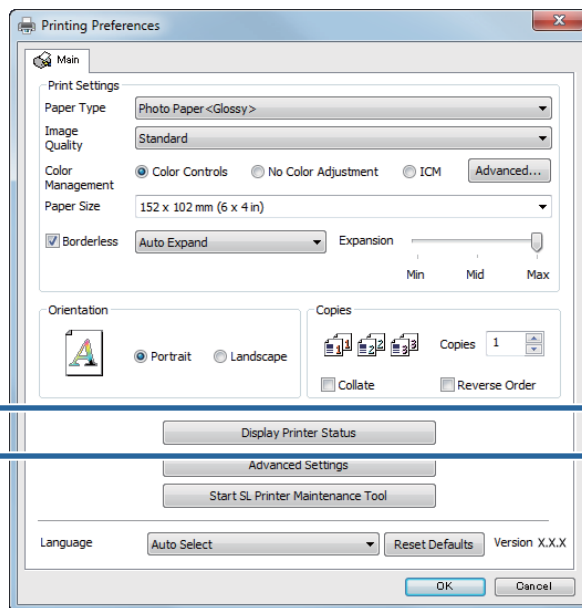

- 3 Make a note of the Paper Level from Paper Setup from Printer.

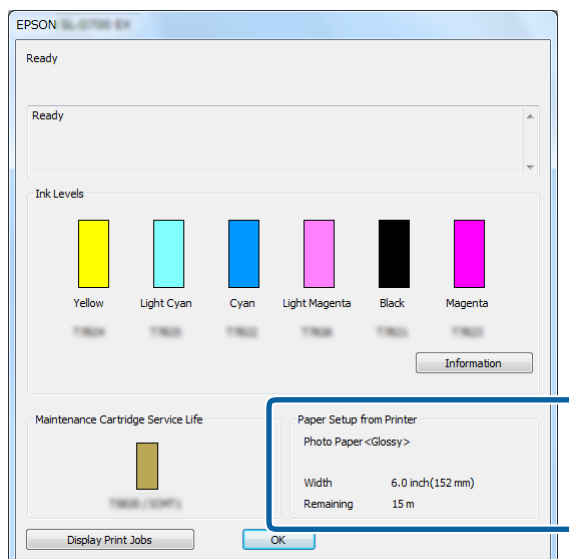

Replacing Paper

Mac

- 1 Start the Maintenance Tool.
See the following for information on starting the Maintenance Tool.
[See “Error Messages \(Mac\)” on page 71](#)
- 2 Click **Printer Window**.

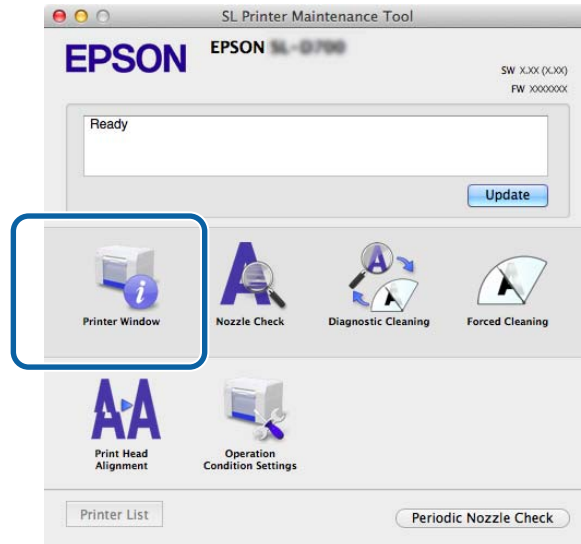

The **Printer Window** screen is displayed.

- 3 Make a note of the Paper Level from Paper Setup from Printer.

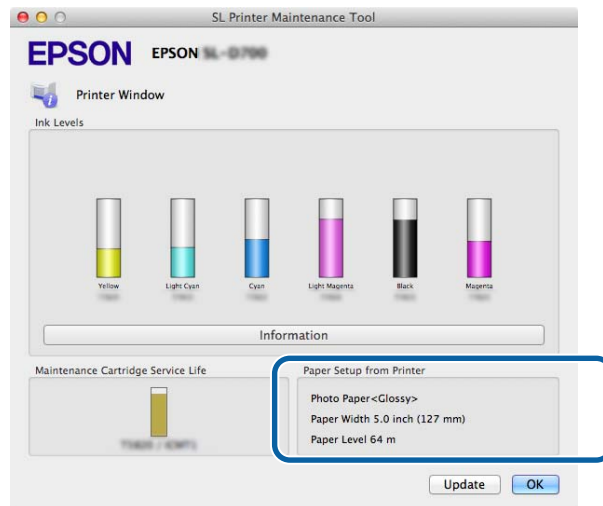

Removing the Roll Paper Spindle from the Printer

! *Important:*

When the  light is lit and paper is ejected from the eject slot, the printer is out of paper.



- 1 Check that the printer's  light is lit and isn't flashing.

! *Important:*

Make sure the power is on before replacing paper.

- 2 Press the  button and wait until the  light turns on.

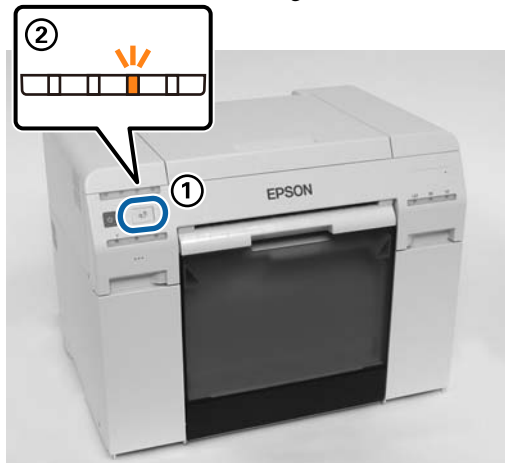

- 3 Remove the scrap paper box and empty out the scrap paper.
See [“Emptying the Scrap Paper Box”](#) on page 61

Replacing Paper

- 4 Grip the handle to release the roll paper feeder and pull it out.

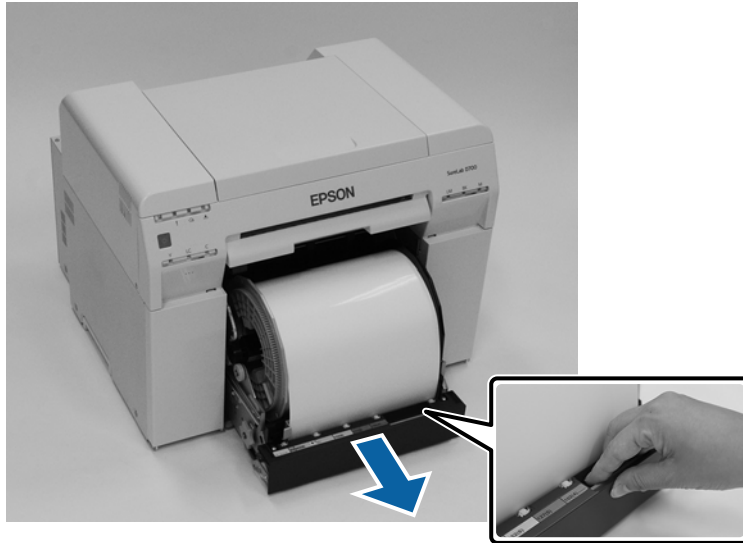

! **Important:**

If you cannot remove the roll paper feeder for some reason, do not try to pull it out by force. Paper may be jammed inside the printer. Remove the paper by following the procedure in "Paper is Jammed in the Internal Paper Feeder".

See "Paper is Jammed in the Internal Paper Feeder" on page 92

- 5 Remove the roll paper spindle.

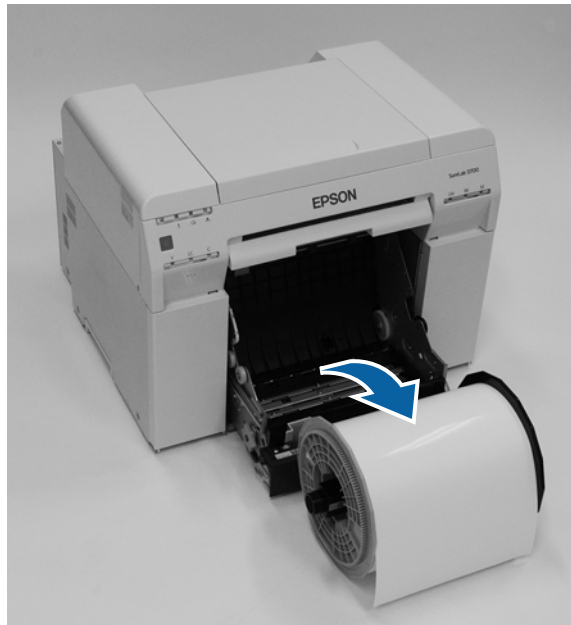

Removing the Roll Paper from the Spindle

- 1 Stand the roll paper spindle on a flat surface and remove the gray adapter.

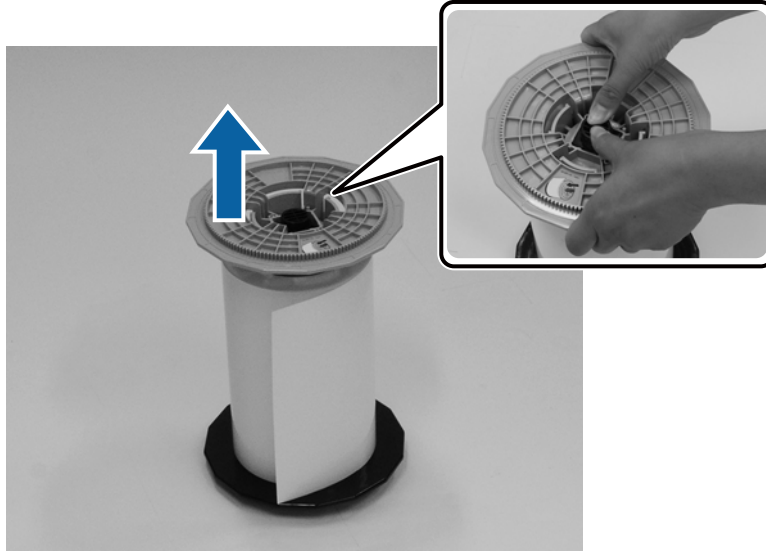

- 2 Remove the paper.

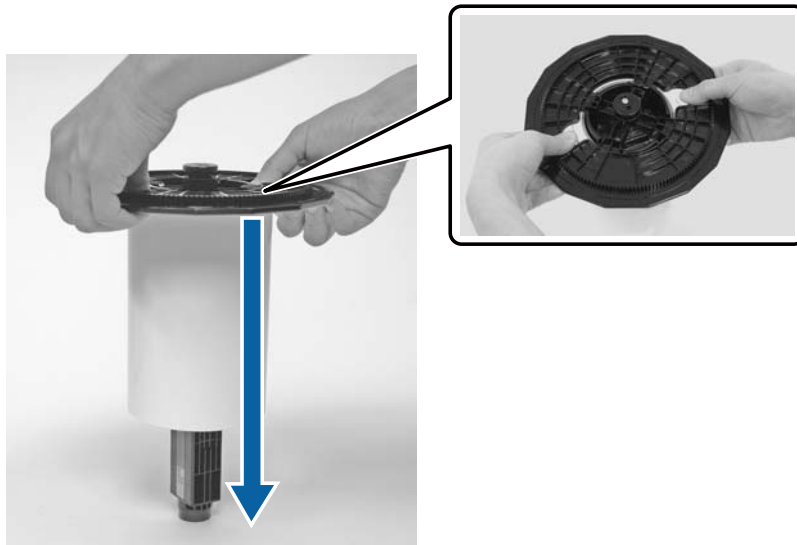

Note:

After carefully rewinding the paper, place it in its original packaging, and then store the paper.

Replacing Paper

Placing Roll Paper on the Spindle

- 1 Remove the new paper from its packaging, and stand it on a flat, clean surface. Wipe the edge of the paper with a soft, clean cloth several times to remove any dust. Flip the paper roll and repeat the process.



- 2 Place the paper roll on the spindle so that the paper winds clockwise.

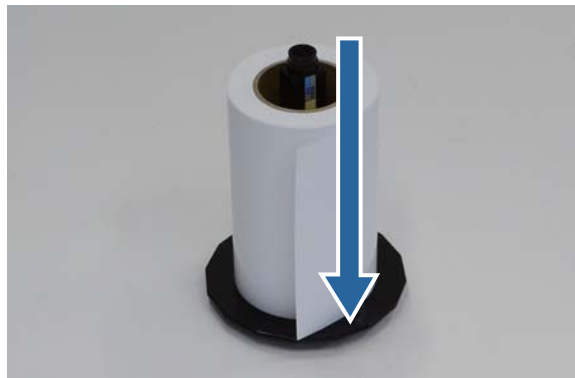

Replacing Paper

- 3 Insert the gray adapter onto the spindle and press down until there is no gap between the adapter and the roll paper.

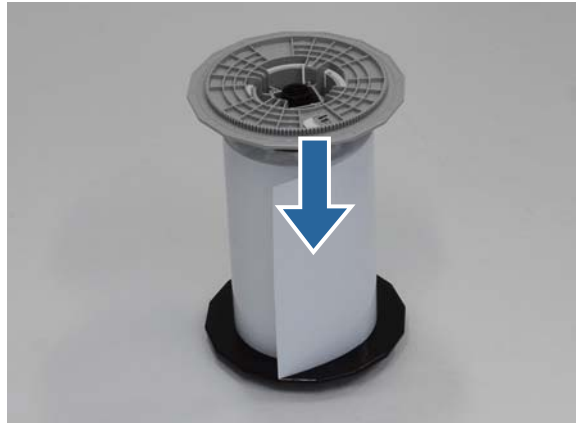

Inserting the Roll Paper Spindle

- 1 To adjust the position of the inner edge guide, lift it towards you slightly and slide it to the width of the roll paper.

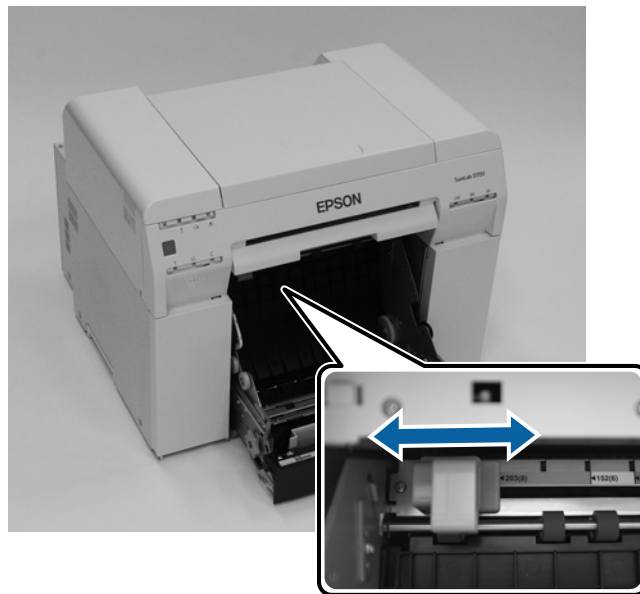

Replacing Paper

- 2 Hold the roll paper spindle in the orientation shown below, and place it in front of the roll paper feeder. Remove any tape or protective material from the paper. If the leading edge of the paper is not straight, cut it in a straight line with a pair of scissors.

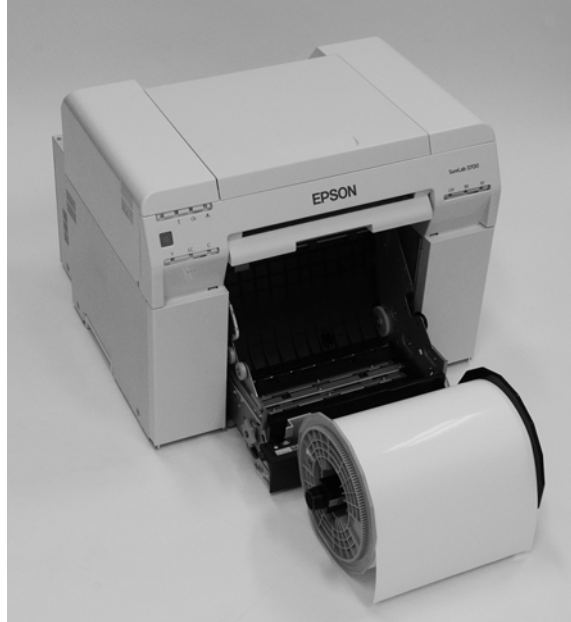

- 3 Load the roll paper spindle in the roll paper feeder with the gray adapter on the left. Check that the roll paper spindle fits between the rollers as shown.

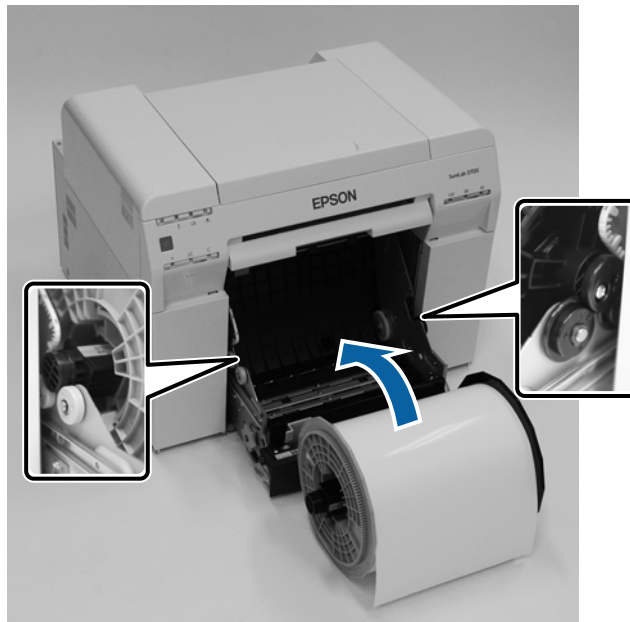

Replacing Paper

- 4 Lift the front edge guide and slide it to the width of the paper.

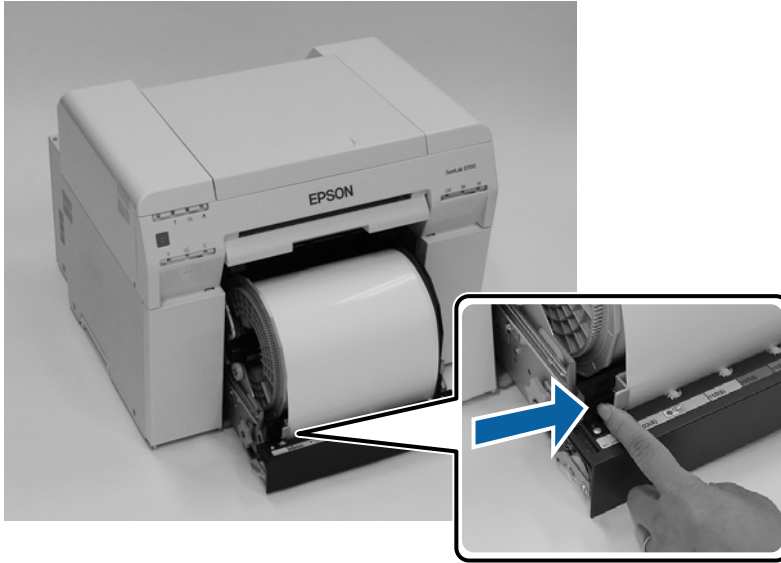

- 5 Insert the leading edge of the paper into the paper feed slot until the paper light turns on.
Make sure the leading edge is cut straight across to avoid paper feeding problems.

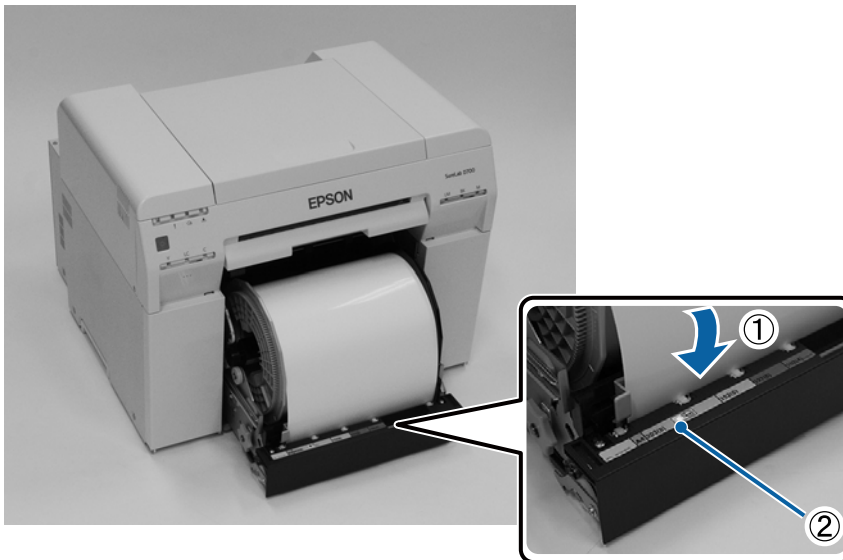

Replacing Paper

Note:

If the paper light does not turn on, turn the knob counter clockwise, and then insert the paper again.

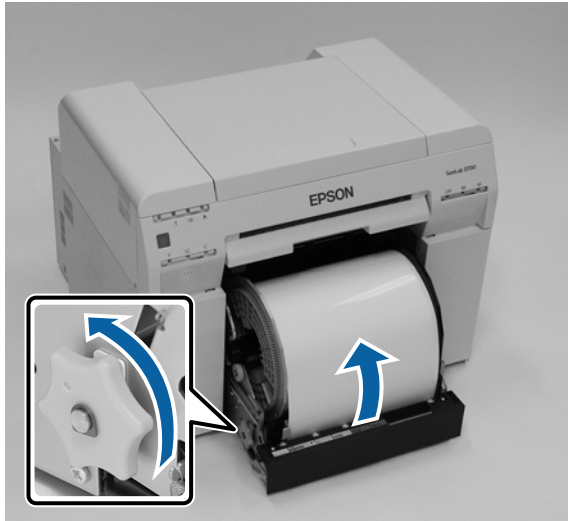

- 6** Push the roll paper feeder into the printer.



- 7** Carefully roll the paper into the printer to remove any slack.



Replacing Paper

! **Important:**

If the paper is slack, print quality may decline, and paper jams could occur.

8

Attach the scrap paper box.

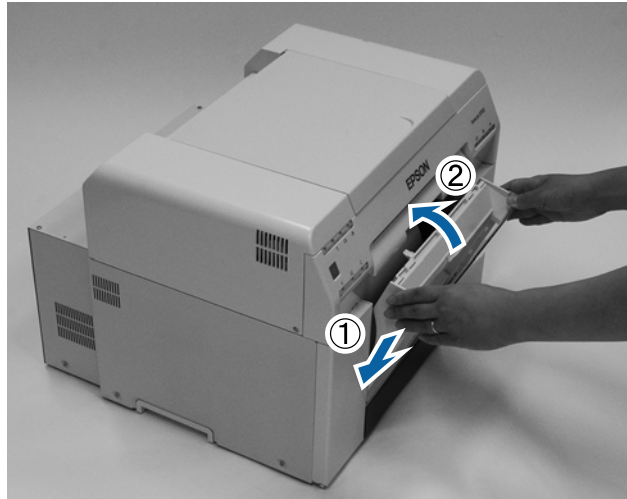

Check that the printer's  light is off.

! **Important:**

If the paper is left loaded in the printer for long periods of time, the leading edge of the paper may curl and print quality may decline. Epson recommends removing paper from the printer when it is not in use.

Replacing Paper

Changing Paper Settings

After replacing paper, set the Paper Type and the Paper Level in the Maintenance Tool.

See the "Maintenance Tool Operation Guide" for more details on the Maintenance Tool.

Windows

Set the **Paper Type** and **Paper Level** in **Paper Settings - Current media**, and then click **Set**.

The paper width set in **Paper Width** is displayed.

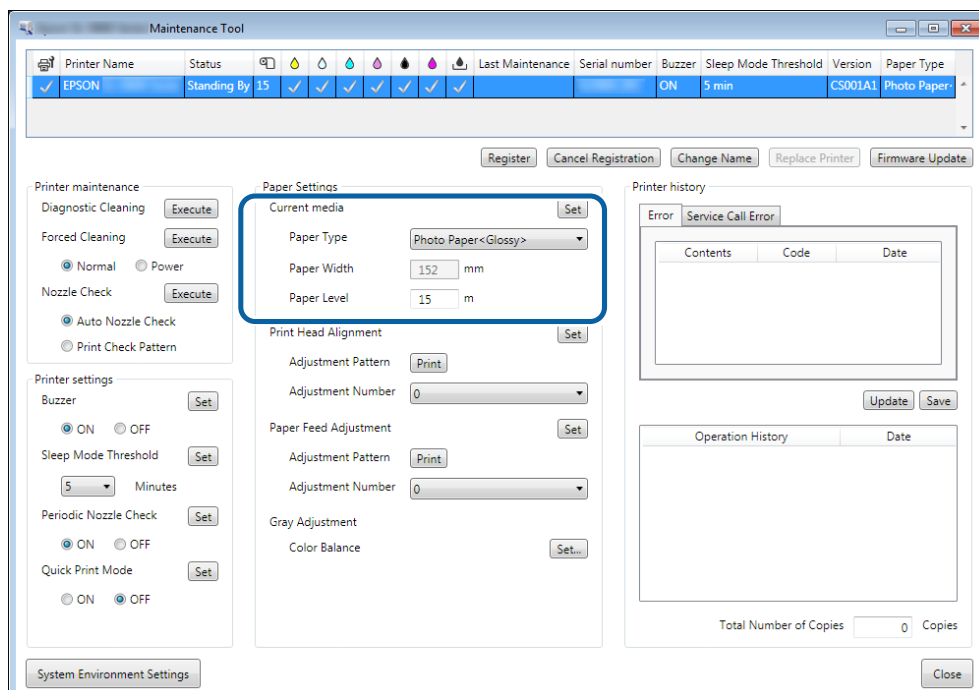

Replacing Paper

Mac

- 1 Click **Operation Condition Settings** on the Maintenance Tool's main screen.

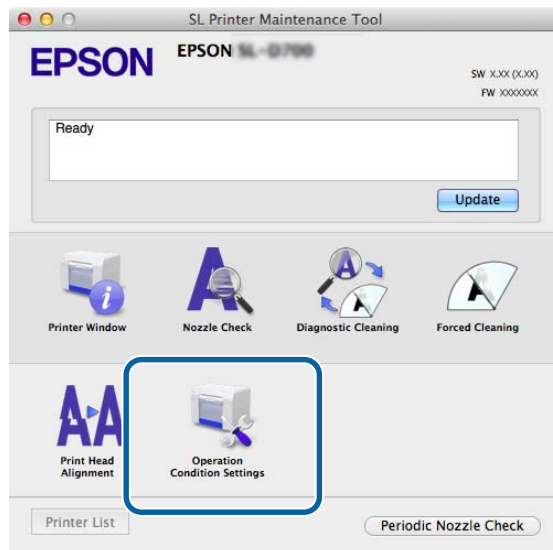

- 2 Select **Change the paper type and the paper remaining**.
When this is selected, you can change the **Paper Type** and **Paper Level**.

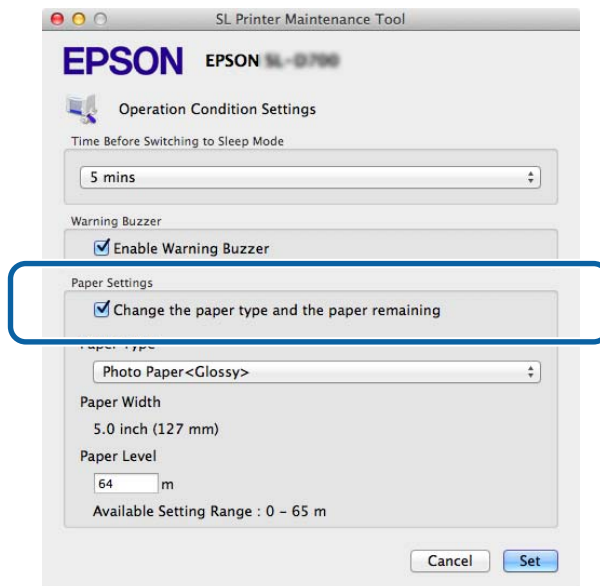

Replacing Paper

3

Set the **Paper Type** and the **Paper Level**, and then click **Set**.
The paper width set in **Paper Width** is displayed.

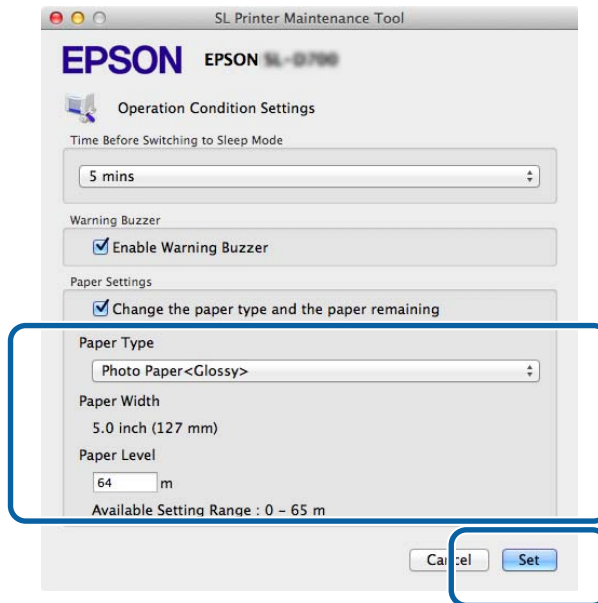

Paper Output

Printed paper is ejected from the front of the printer. Epson recommends that you use genuine Epson paper (available in 5, 6, or 8 inch widths), but you can use a variety of roll paper in sizes from 3.5 to 8.3 inches wide. By attaching the optional print tray or large print tray, you can collect multiple print outs. See the following for more details.

Print Size		Output Location	Capacity	
Length*	Width		Glossy/Luster	Matte
3.5 to 4 inches (89 to 102 mm)	5 to 8 inches (127 to 203 mm)	Print tray (optional)	20 copies	20 copies
4 to 8 inches (102 to 203 mm)		Print tray (optional)	20 copies	10 copies
		Large print tray (optional)	5 copies	1 copy
8 to 12 inches (203 to 305 mm)		Large print tray (optional)	5 copies	1 copy

* For prints longer than 12 inches (305 mm), remove the optional print tray or the large print tray, and eject one copy at a time from the front of the printer.



Ejecting Paper

! **Important:**

- Do not pull paper that is being ejected.
- When paper is being ejected from the front, do not pull it or raise it higher than the output slot. Otherwise, print quality may decline.



Note:

When removing the scrap paper box, make sure you remove the print tray first.

Print tray (optional)

After printing, the paper is cut to the specified size and ejected to the print tray.



Ejecting Paper

Large print tray (optional)

After printing, the paper is cut to the specified size and ejected to the large print tray.



Attaching the Print Tray (Optional)



- 1 Tilt to insert the hooks, and then lower to hook it in place.

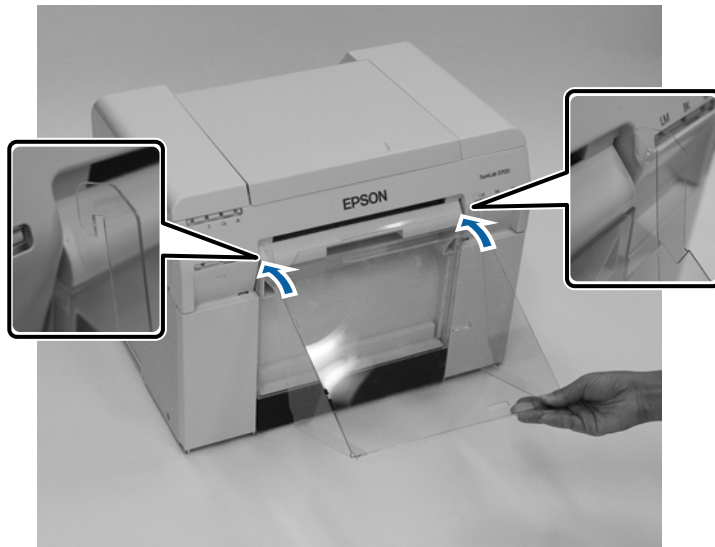

Ejecting Paper

2

When the length of the print size is 3.5 to 4 inches (89 to 102 mm), place the hooks into the top holes.
When the length of the print size is 4 to 8 inches (102 to 203 mm), place the hooks into the bottom holes.

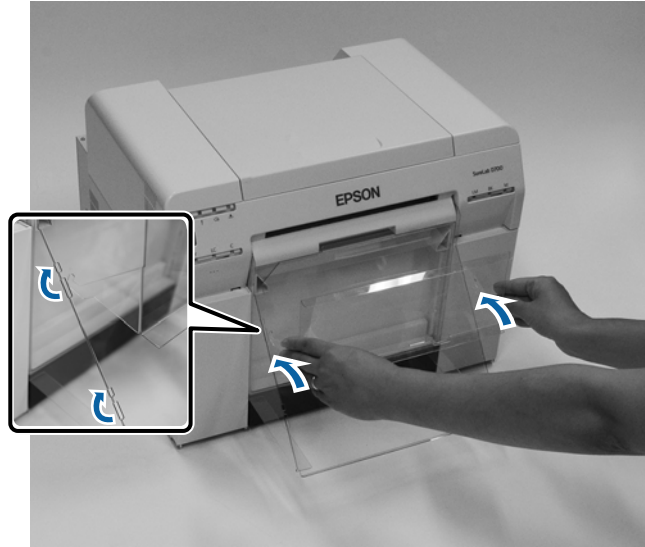

Attaching the Large Print Tray (Optional)



- 1 Tilt to insert the hooks, and then lower to hook it in place.

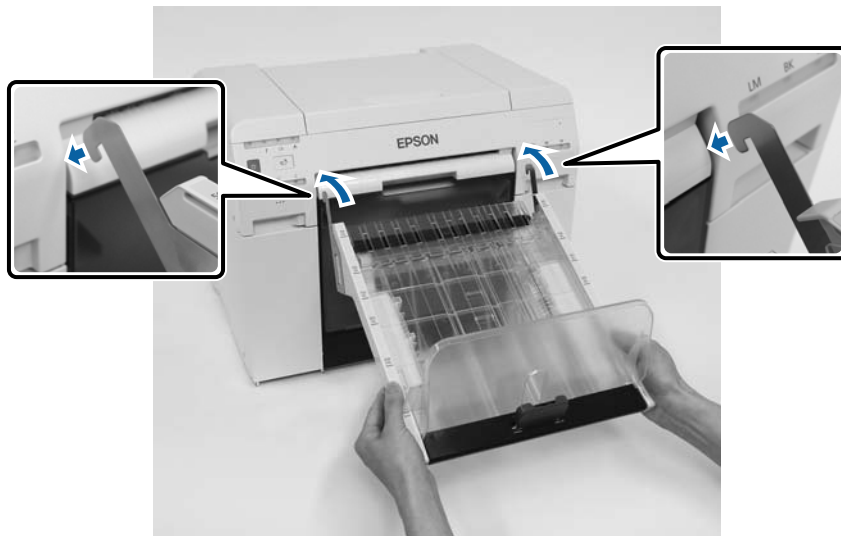

Ejecting Paper

2

Pinch the handle and move it to match the length of the printer size.



Replacing Ink Cartridges



Caution:

- Do not disassemble ink cartridges.
If disassembled, ink could get in your eyes or adhere to your skin.
- Do not shake the ink cartridges too vigorously; this can cause them to leak.
- Keep ink cartridges out of the reach of children and do not drink the ink.
- If ink gets on your skin, wash it thoroughly with soap and water. If ink gets into your eyes, flush them immediately with water. If ink gets into your mouth, spit it out and see a doctor right away.



Important:

- See the following points when working with ink cartridges.
[“Notes on Ink Cartridges” on page 21](#)
- If you do not have a new ink cartridge for installation, leave the expended ink cartridge in the printer until the new one is ready. If the printer is left without the ink cartridges, it may malfunction.
- When an ink cartridge is running low, replace it with a new ink cartridge as soon as possible.
- Do not leave the printer without ink cartridges installed. The inks inside the printer may dry and you may not be able to print. When you are not using the printer, make sure there is an ink cartridge installed in each slot.

Checking Ink Levels

Checking from the Printer

The ink lights on the front of the printer light up when the corresponding ink cartridge is low.

See [“Front” on page 6](#)

Ink light

Replacing Ink Cartridges

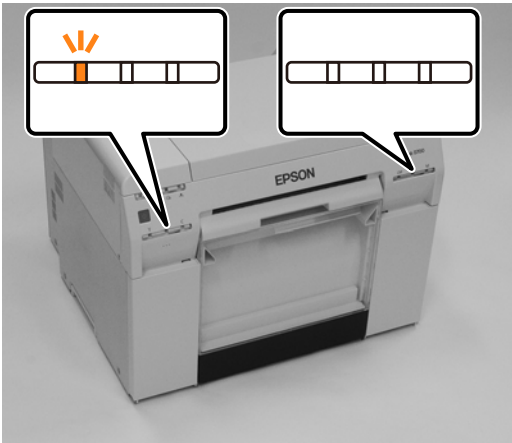

Checking from the Computer

Windows

- 1 Click **Display Printer Status** in the printer driver .

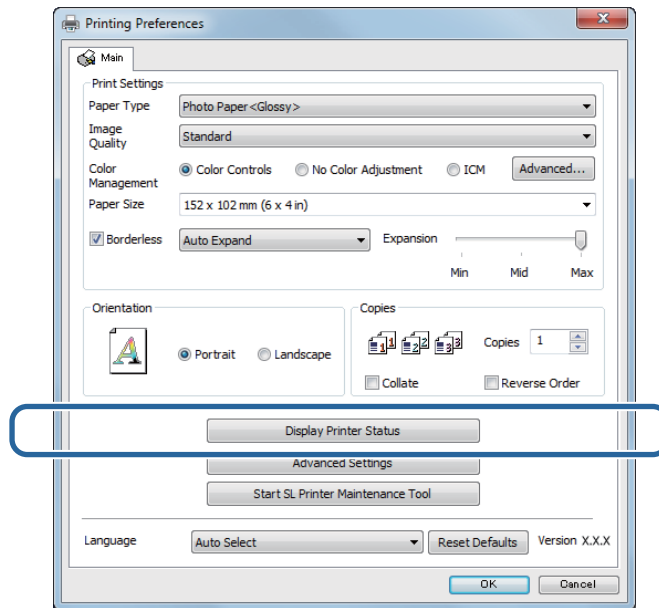

Replacing Ink Cartridges

2

Check how much ink remains.

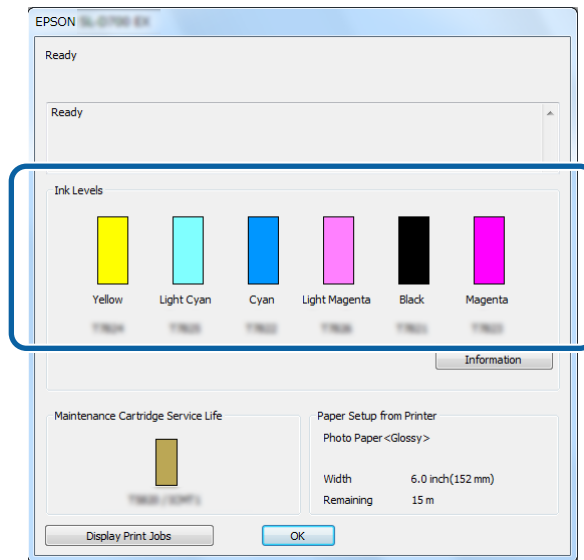

When you have finished checking, click **OK**.

Replacing Ink Cartridges

Mac

- 1 Start the Maintenance Tool.
See the following for information on starting the Maintenance Tool.
[See “Error Messages \(Mac\)” on page 71](#)
- 2 Click **Printer Window** on the main screen.

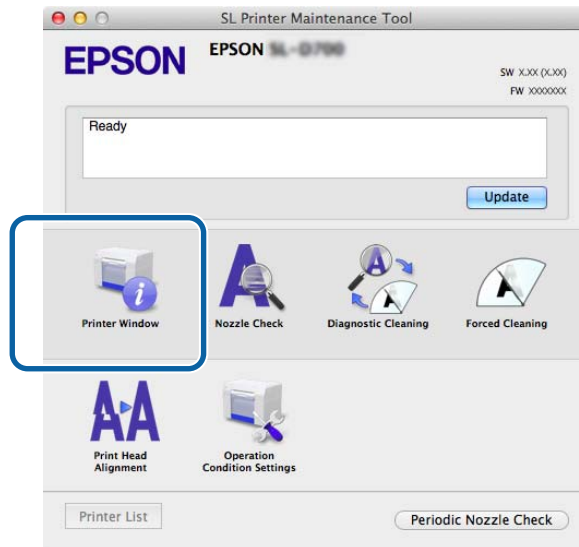

The **Printer Window** screen is displayed.

- 3 Check how much ink remains.

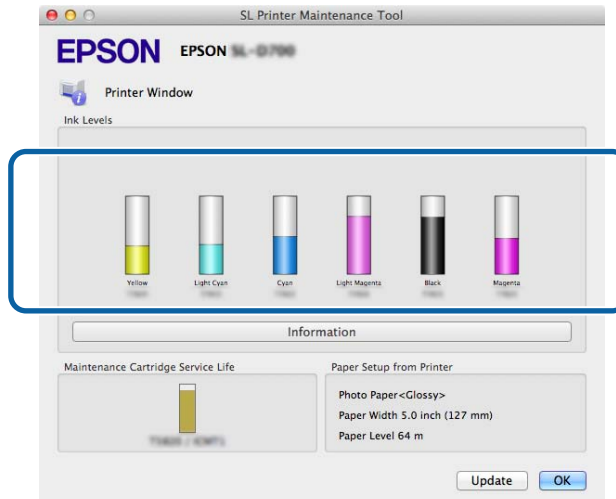



When you have finished checking, click **OK**.

Replacing the Ink

! *Important:*

- ❑ *Install ink cartridges into each slot. You cannot print if any of the slots are empty.*

- 1 Check that the printer's  light is on.
If the  light is flashing, the printer is operating. Wait until all operations have stopped.
- 2 The ink light indicates if it is necessary to replace the ink cartridges.
In this example we are replacing the Y (yellow) cartridge. The procedure is the same for the other colors.

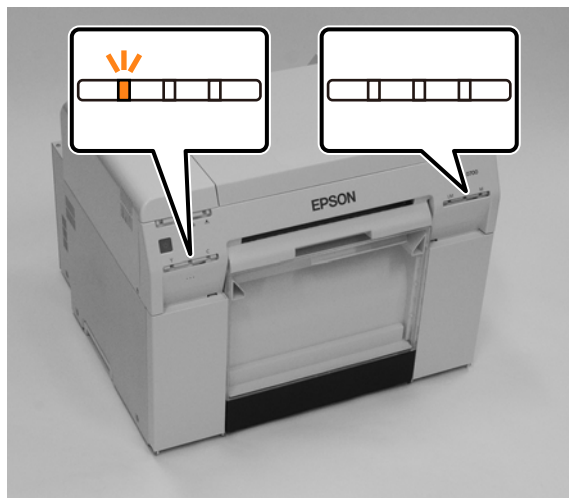

Replacing Ink Cartridges

- 3** Open the cartridge cover on the side that needs to be replaced.
A warning buzzer sounds when you open the cover.



- 4** Gently push in the empty ink cartridge so that it pops out a little, and then remove.
See the following for more information on disposing of ink cartridges.
[“Disposing of Used Ink Cartridges and Maintenance Tanks” on page 22](#)

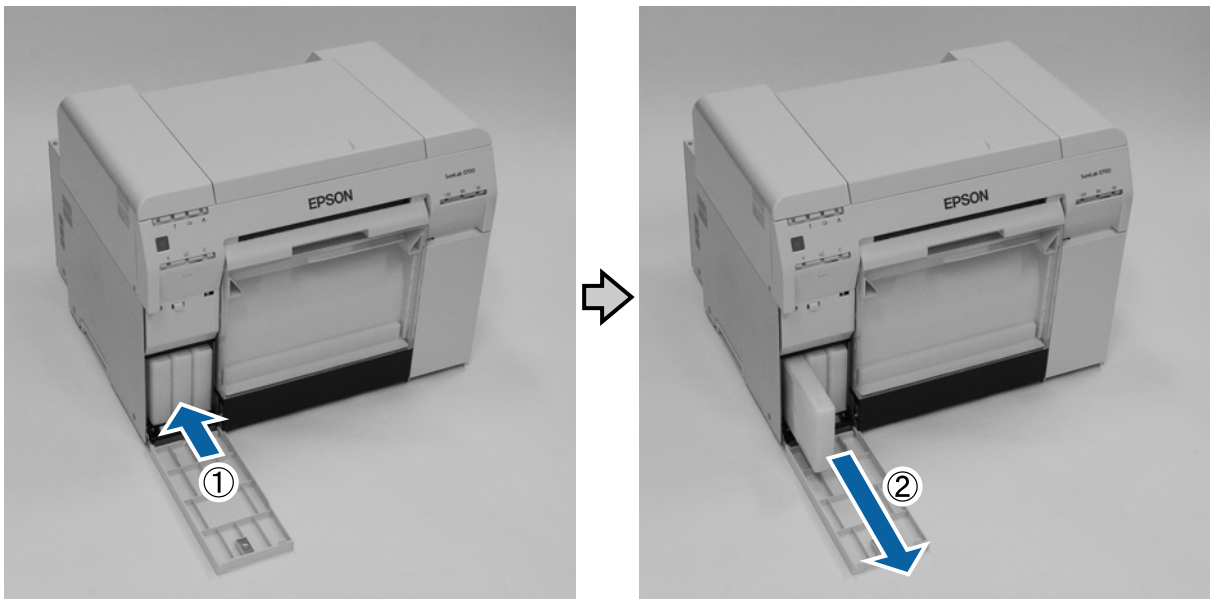

Replacing Ink Cartridges

! **Important:**

Removed ink cartridges may have ink around the ink supply port, so be careful not to get any ink on the surrounding area when removing the cartridges.

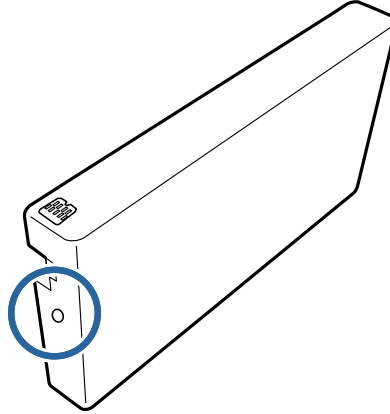

5

Remove the new ink cartridge from the box.

! **Important:**

- Do not touch the chip (A) on the ink cartridge. Doing so may affect normal operation and printing.
- Do not touch the ink supply port (B) on the ink cartridge. Ink could leak out.

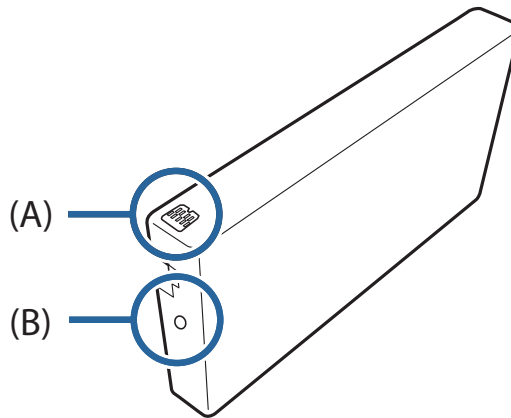

Replacing Ink Cartridges

- 6 Slide the ink cartridge all the way into the printer.



- 7 Close the cartridge cover.



- 8 Check that the printer's  light is lit and isn't flashing.

Replacing the Maintenance Tank

The maintenance tank absorbs ink consumed during head cleaning. This section explains how to replace used maintenance tanks.

 **Important:**

After removing the maintenance tank, do not leave the cartridge cover open, install a new tank immediately.

Checking the Free Space in the Maintenance Tank

Checking from the Printer

When it is time to replace the maintenance tank, the printer's  light turns on.

See “Lights” on page 12



Replacing the Maintenance Tank

Checking from the Computer

Windows

1 Click **Display Printer Status** in the printer driver.

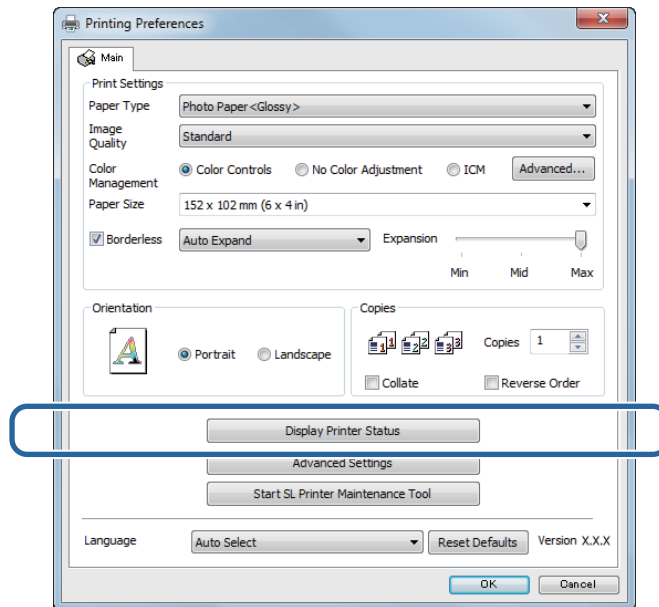

2 Check the free space in the maintenance tank.

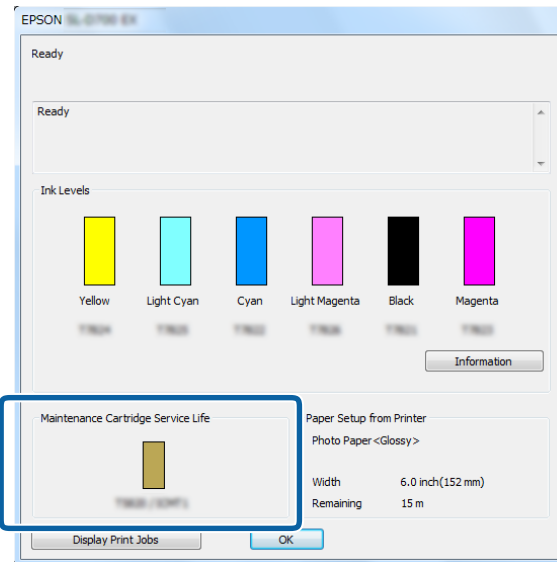

When you have finished checking, click **OK**.

Replacing the Maintenance Tank

Mac

- 1 Start the Maintenance Tool.
See the following for information on starting the Maintenance Tool.
[See “Error Messages \(Mac\)” on page 71](#)
- 2 Click **Printer Window** on the main screen.

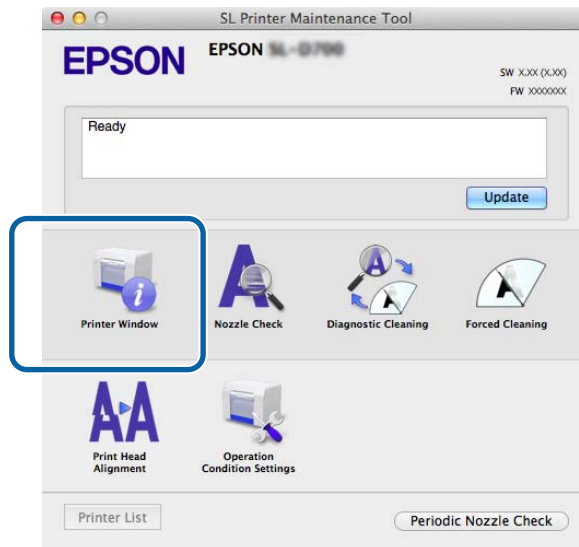

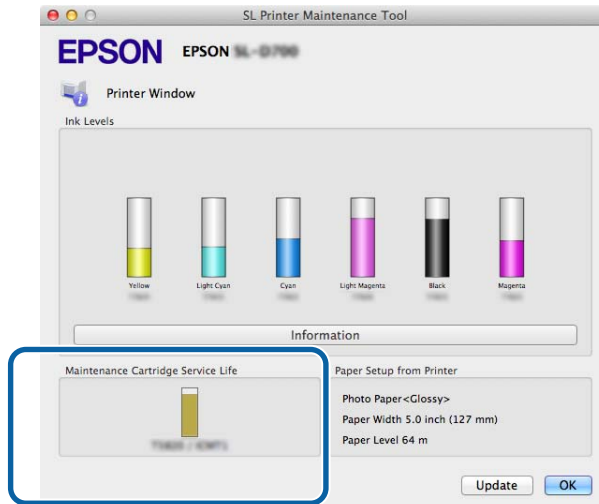

The **Printer Window** screen is displayed.

- 3 Check the free space in the maintenance tank.



When you have finished checking, click **OK**.

Replacement Procedure

- 1 Check that the printer's  light is on.
If the  light is flashing, the printer is operating. Wait until all operations have stopped.
- 2 Open the cartridge cover on the right.
A warning buzzer sounds when you open the cover.



- 3 Be careful not to tilt the maintenance tank, and remove it carefully.
Push up, and then pull it out.
See the following for more information on disposing of maintenance tanks.
[“Disposing of Used Ink Cartridges and Maintenance Tanks” on page 22](#)



Replacing the Maintenance Tank

- 4 Prepare a new maintenance tank.

! *Important:*

Do not touch the chip on the maintenance tank. Doing so may affect normal operation and printing.

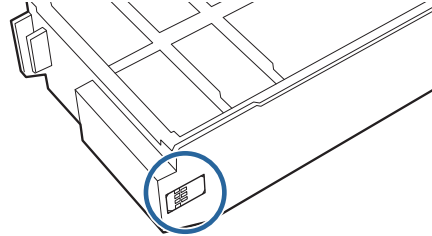

- 5 Insert the new maintenance tank.



- 6 Close the cartridge cover.





- 7 Check that the printer's  light is lit and isn't flashing.

Emptying the Scrap Paper Box

Scraps of paper cut during printing accumulate in the scrap paper box. You need to empty out the paper scraps before the box is full.

Check visually how much scrap paper has accumulated in the box. Empty the scrap paper box when you replace the paper.

- 1** Check that the printer's  light is on.
If the  light is flashing, the printer is operating. Wait until all operations have stopped.
- 2** Remove the scrap paper box.
Pull the top section forward and then lift out the bottom section.

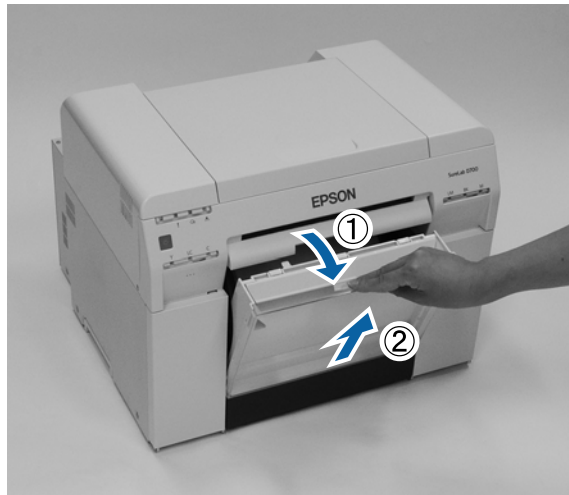

- 3** Empty out the scrap paper.

 **Important:**

After emptying the scrap paper, check that the flap for the scrap paper box is in the correct position as shown in the following photo.



Emptying the Scrap Paper Box

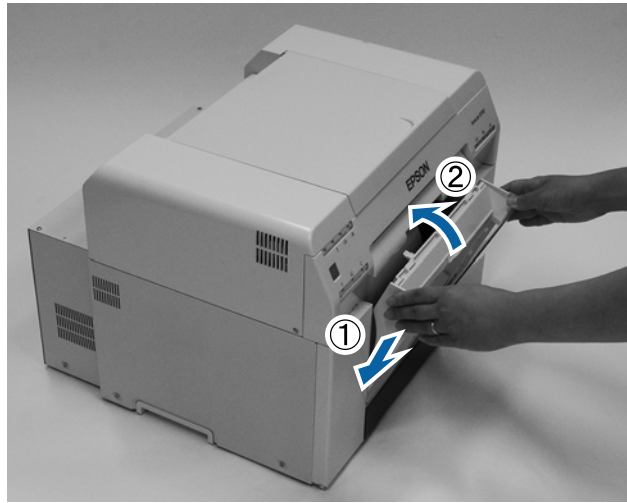

- 4 Attach the scrap paper box.
Insert the bottom section, and then push the top section into place.



- 5 Check that the printer's  light is lit and isn't flashing.

Cleaning the Platen

When the back of print outs is dirty, paper dust has accumulated on the platen. Follow the steps below to clean the platen. Perform cleaning with the power on.

- 1** Press the  button and wait until the  light turns on.

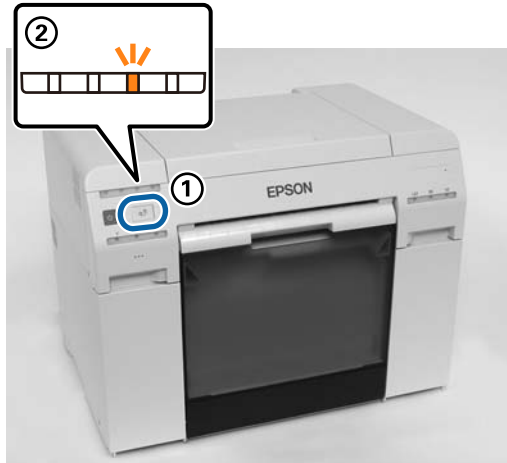

- 2** Open the top cover by sliding it forward.



 **Important:**

- Do not move the print head unit manually with too much force.
- Do not touch the rollers inside the printer. This could cause print outs to be soiled.
- Do not touch the ink tubes inside the printer. Otherwise, it may breakdown.

Cleaning the Platen

- 3 Wipe off any paper dust (this is normally white dust) on the platen (the blue sections in the following figure) with a commercially available cotton swab.



! **Important:**

Do not use a dirty swab when cleaning the platen.

- 4 Wipe off any paper dust that has accumulated in the borderless absorbent areas (the blue sections in the following figure) with a commercially available cotton swab.



Cleaning the Platen

- 5** If there is no paper dust on the right side of the platen, go to step 7.
If there is paper dust on the right side of the platen, press the  button for three seconds.

The print head moves to the left.



- 6** Perform steps three and four to wipe off any paper dust.

- 7** Press the  button for three seconds.

The print head moves to the right.

- 8** Close the top cover.



Maintenance

Maintenance Tool

With the Maintenance Tool, you can perform various adjustment and maintenance operations from your computer.

Windows

In operator mode, you can only use **Current media** for **Printer maintenance** and **Paper Settings**.

Items of the Main Screen	Settings
Printer maintenance	Perform print head maintenance functions such as Diagnostic Cleaning , Forced Cleaning , and Nozzle Check .
Paper Settings	Set the Paper Type and the Paper Level . Make these settings when replacing the paper. You can also perform printer adjustment functions such as Print Head Alignment , Paper Feed Adjustment , and Gray Adjustment .
Printer settings	You can execute various printer settings such as the Buzzer , Sleep Mode Threshold , Periodic Nozzle Check , and Quick Print Mode .
Printer history	Check the Operation History , and save log files in Collect Logs .
Printer Management	You can execute printer management operations such as Register , Cancel Registration , and Replace Printer .

Mac

Main Screen Menu	Settings
Message	Displays the printer's status.
Printer Window	Allows you to check the amount of ink remaining, the free space in the maintenance tank.
Nozzle Check	Allows you to print a check pattern and visually check for clogged nozzles.
Diagnostic Cleaning	Detects clogged nozzles and automatically performs cleaning.
Forced Cleaning	Performs manual cleaning.
Print Head Alignment	Corrects the print misalignment.
Operation Condition Settings	Allows you to make various printer settings such as Time Before Switching to Sleep Mode , Warning Buzzer , Quick Print Mode , and Paper Settings .
Printer List	Displays a list of available printers allowing you to select the printer you want to configure.
Periodic Nozzle Check	Allows you to set whether or not to automatically perform a nozzle check.

See the "Maintenance Tool Operation Guide" for more details.

Regular Maintenance

To keep your printer working correctly and to prevent any issues with print quality, perform the regular maintenance described below.

Check Part	Contents	Checking Time	Reference
Scrap paper box	Empty out the scrap paper.	When replacing paper	See "Emptying the Scrap Paper Box" on page 61
Airflow vent	Clean the airflow vent filter with a vacuum cleaner.	Every three months	See "Vacuuming the Airflow Vents" on page 67

Vacuuming the Airflow Vents

Clean the airflow vent filter with a vacuum cleaner.



Troubleshooting

Note:

See the "Printer Driver Operation Guide" for more details on troubleshooting the printer driver.

See Printer Driver Operation Guide" - "Troubleshooting"

When an Error Occurs

Light Status

When the warning buzzer sounds or the lights turn on or flash, check the solutions in the following table and take the recommended steps.

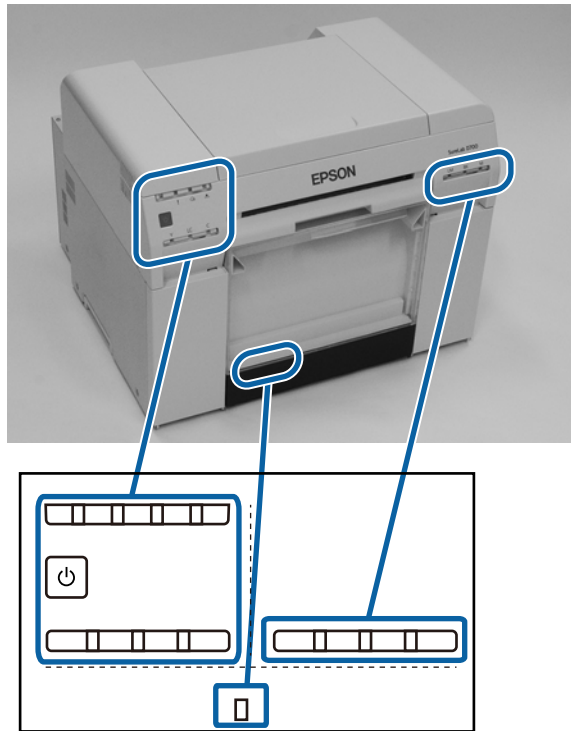

Troubleshooting

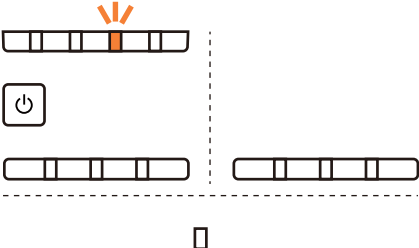
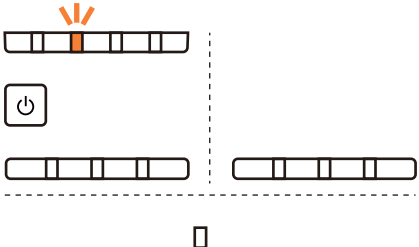
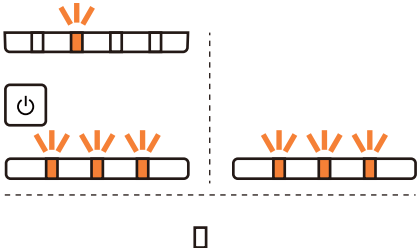
Light Indicator	Warning Buzzer*	Problems and Solutions
<p>☐ light on Paper light off</p> 	None	<p>There is no paper loaded in the roll paper feeder. Load the paper.</p> <p>See "Replacing Paper" on page 25</p>
<p>! light on</p> 	The warning buzzer continues to sound intermittently until you remove the scrap paper box.	<p>Operations have stopped because an error has occurred, the printer is performing error recovery operations, or a printer system error has occurred.</p> <ul style="list-style-type: none"> ☐ Check the code on the computer's screen. See the following to solve the problem. See "Errors and Solutions (Mac)" on page 77 ☐ Contact your local dealer if a printer system error has occurred.
<p>! light on</p> 		<p>The ink cartridge indicated by the ink light is expended, or an error has occurred. Replace the ink cartridges.</p> <p>See "Replacing Ink Cartridges" on page 48</p>

Troubleshooting

Light Indicator	Warning Buzzer*	Problems and Solutions
<p>! light on ☐ light on Paper light off</p>	<p>The warning buzzer continues to sound intermittently until you remove the scrap paper box.</p>	<p>There is no paper loaded in the roll paper feeder, or the paper has run out. Load the paper.</p> <p>See "Replacing Paper" on page 25</p>
<p>! light on ☐ light flashing</p>		<p>Paper is jammed or the paper has not been fed correctly. Clear the paper jam, or feed the paper again.</p> <p>See "Paper Jams" on page 84</p>
<p>! light on ☑ light on</p>		<p>The ink remaining in the cartridge indicated by the ink light has fallen below the minimum value, or an error has occurred. Replace the maintenance cartridge(XXXX).</p> <p>See "Replacing the Maintenance Tank" on page 56</p>
<p>All lights flashing</p>		<p>Continues sounding until the power button is turned off.</p>

* You can turn the warning buzzer on and off in the Maintenance Tool.

Error Messages (Windows)

Error messages are displayed when an error occurs in the printer while printing.

The code, error details, and solutions are displayed on the screen.

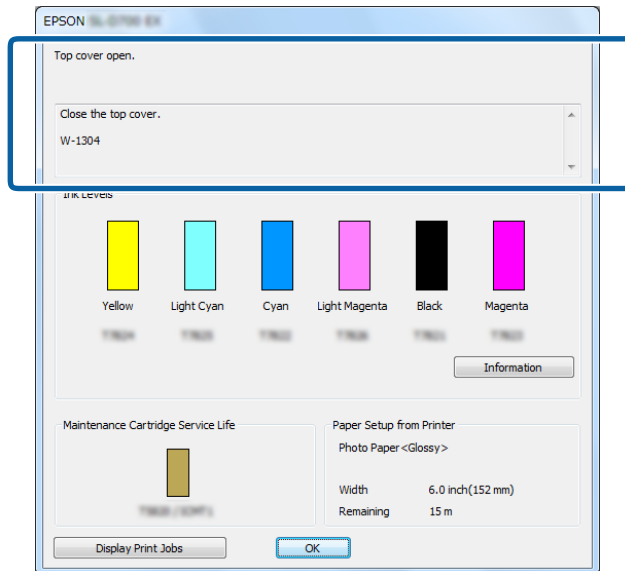

Error Messages (Mac)

When errors occur in the printer while printing, you can check the content of the error and solutions with the Maintenance Tool. Click **Printer Window** to display a detailed error message.

See the "Maintenance Tool Operation Guide" for more details on the Maintenance Tool.

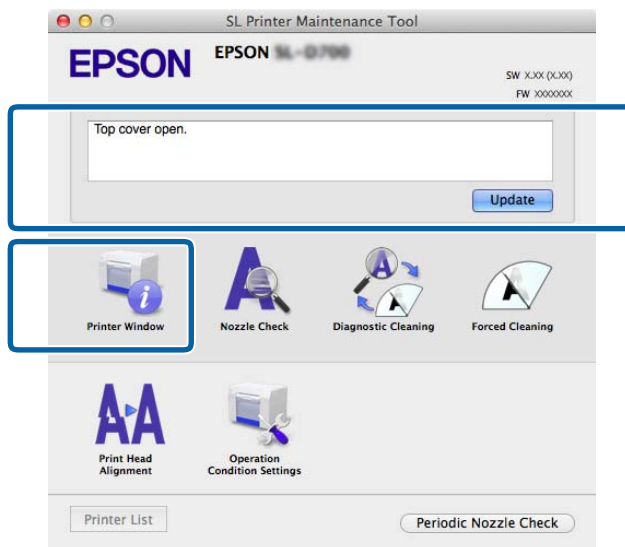

Use one of the following methods to start the Maintenance Tool.

- 1 Select **System Preferences > Print & Scan** (or **Print & Fax**) from the **Apple** menu.

Troubleshooting

2

Select the printer and click **Options & Supplies > Utility > Open Printer Utility.**

Errors and Solutions (Windows)

Check the details of the error displayed, and then take the necessary measures.

Code	Message	What to do
W-2301 to W-2303 W-2305 to W-2306	Cannot perform [Detect Clogging] correctly. Start [Maintenance tool], select [Printer maintenance] and perform [Diagnostic Cleaning]. Contact service support if the error continues to occur.	Perform Diagnostic Cleaning in the Maintenance Tool. See the "Maintenance Tool Operation Guide" for more details on the Maintenance Tool. If "Auto nozzle check failed." is displayed on the Windows screen, contact Epson Product Support .
I-2307	Cannot perform [Detect Clogging] correctly. Room temperature may not be within the guaranteed operating range. Check the room temperature.	Check the room temperature. Use within the recommended operating temperature range.
W-2311	Clogged nozzle(s) detected. Start [Maintenance tool], select [Printer maintenance] and perform [Diagnostic Cleaning].	Perform Diagnostic Cleaning in the Maintenance Tool. See the "Maintenance Tool Operation Guide" for more details on the Maintenance Tool.
I-2401	Replace the maintenance cartridge soon. Prepare a new maintenance cartridge(xxxx). You can continue printing until replacement is required.	Check the message, and then click OK . Prepare a new maintenance cartridge with the model number displayed in xxxx. See "Replacing the Maintenance Tank" on page 56
I-2201	Ink Low (xxxx) Prepare a new ink cartridge. You can continue printing until replacement is required. Epson recommends the genuine Epson cartridges listed above.	Check the message, and then click OK . Prepare a new ink cartridge for replacement. See "Replacing Ink Cartridges" on page 48
I-2101 to I-2104	It is nearly time to replace parts. xxxxxx Contact a technical representative. You cannot print if parts have reached the end of their service life.	Contact Epson Product Support and request replacement for the part displayed in xxxxxx.
W-1301	The scrap paper box has come off. Install the scrap paper box correctly.	Attach the scrap paper box. If a message is displayed, check the details.

Troubleshooting

Code	Message	What to do
W-1302	Cartridge cover (right) open. When replacing a cartridge, check the location and the cartridge type. Close the cartridge cover.	Close the cartridge cover (right). If a message is displayed, check the details.
W-1303	Cartridge cover (left) open. When replacing a cartridge, check the location and the cartridge type. Close the cartridge cover.	Close the cartridge cover (left). If a message is displayed, check the details.
W-1304	Top cover open. Close the top cover.	Close the top cover. If a message is displayed, check the details.
W-1305	Rear cover open. Close the rear cover.	Close the rear cover. If a message is displayed, check the details.
I-1311	Check the scrap paper box. Empty the box if it is full.	Check the scrap paper box. Check the scrap paper box, and empty it if it is full. See "Emptying the Scrap Paper Box" on page 61
W-1101	A paper jam has occurred. Remove any paper remaining from the roll paper feeder, and then reload the paper.	Remove the paper from the roll paper feeder, and then reload the paper. See "Paper Jams" on page 84
W-1102	A paper jam has occurred. Open the rear cover and the top cover, remove any paper remaining, and then reload the paper.	Remove the paper from the internal paper feeder, and then reload the paper. If the printer is setup so that you cannot access the rear of the printer to perform maintenance, contact Epson Product Support See "Paper Jams" on page 84
W-1103	An error has occurred in the paper feeding unit. Reload the paper in the same way as when replacing paper.	Check that there is no paper inside the printer, and then reload the paper. If a message is displayed, check the details. See "Replacing Paper" on page 25
W-1104	Paper is not loaded correctly. Check the positions of the edge guides, and then reload the paper.	Check that there is no paper inside the printer, and then reload the paper. When loading the paper, match the inner edge guide and the front edge guide to the width of the paper. If a message is displayed, check the details. See "Replacing Paper" on page 25
W-1105	Paper is out. Load paper.	Check that there is no paper inside the printer, and then reload the paper. If a message is displayed, check the details. See "Replacing Paper" on page 25
W-1106	Paper is out or not loaded correctly. Load paper.	

Troubleshooting

Code	Message	What to do
W-1108	The width of the loaded paper is not supported. Load supported paper.	Load the appropriate paper. See "Replacing Paper" on page 25
W-1109	Cannot recognize the paper type. Update the paper information.	Update the paper information. See the "Maintenance Tool Operation Guide" for more details on updating the information.
W-2101 to W-2104	Parts have reached the end of their service life. xxxxxx Do you want to continue using the printer or replace parts? If you continue to use the printer, ink could leak or a malfunction could occur. Do you want to continue?	Contact Epson Product Support and request replacement for the part displayed in xxxxxx.
W-2401	Maintenance cartridge not installed Install the maintenance cartridge(xxxx).	Correctly reinstall the maintenance cartridge for the model number displayed in xxxx. See "Replacing the Maintenance Cartridge" on page 56
W-2402	Maintenance cartridge usage exceeded the application limit. Replace the maintenance cartridge(xxxx).	Replace the maintenance cartridge with the model number displayed in xxxx. See "Replacing the Maintenance Cartridge" on page 56
W-2201	Ink cartridge error (xxxx) Please install correct cartridge. Epson recommends the genuine Epson cartridges listed above.	Check the ink cartridge with the color displayed in xxxx, and then replace the cartridge. If a message is displayed, check the details. See "Replacing Ink Cartridges" on page 48
W-2202	Replace Cartridge (xxxx) Epson recommends the genuine Epson cartridges listed above.	Check the ink cartridge with the color displayed in xxxx, and then replace the cartridge. If a message is displayed, check the details. See "Replacing Ink Cartridges" on page 48
W-2203	Ink cartridge error (xxxx) Remove and reinstall them correctly or replace them. Epson recommends the genuine Epson cartridges listed above.	Check the ink cartridge with the color and model number displayed in xxxx, and then replace the cartridge or reinstall it correctly. If a message is displayed, check the details. See "Replacing Ink Cartridges" on page 48

Troubleshooting

Code	Message	What to do
W-2204	Ink cartridge error (xxxx) Please install correct cartridge. Epson recommends the genuine Epson cartridges listed above.	Check the ink cartridge with the color and model number displayed in xxxx, and then replace the cartridge. If a message is displayed, check the details. See "Replacing Ink Cartridges" on page 48
W-2205	Insufficient ink left to perform head cleaning or initial charge. Replace the ink cartridge indicated by the ink light that is turned on. The cartridge being used can be installed again for printing.	Replace the ink cartridge indicated by the ink light that is turned on. If a message is displayed, check the details. See "Replacing Ink Cartridges" on page 48
W-2403	Maintenance cartridge cannot be recognized Install the maintenance cartridge correctly.	Replace or correctly reinstall the maintenance cartridge with the model number displayed in xxxx. If a message is displayed, check the details. See "Replacing the Maintenance Tank" on page 56
W-2404	Insufficient free space in the maintenance cartridge. Replace the maintenance cartridge(xxxx), and then perform head cleaning or initial charge. The cartridge being used can be reinstalled for printing.	Replace the maintenance cartridge with the model number displayed in xxxx. If a message is displayed, check the details. See "Replacing the Maintenance Tank" on page 56
E-5101	The printer is disconnected. Check that the cable is connected, and then turn the printer back on. Contact service support if the error continues to occur. Please order the prints again if there are image files that have not been printed. Code:xxxx	Check that the cables are connected correctly, and then restart the printer. If the error persists, contact Epson Product Support
E-2101 to E-2104	Parts have reached the end of their service life. xxxxxx Contact a technical representative.	Contact Epson Product Support and request replacement for the part displayed in xxxxxx.
E-9901, E-9902	A printer system error occurred. Turn the printer off. Check if there is any paper remaining inside the printer, and then turn the printer back on. Contact service support if the error continues to occur. Please order the prints again if there are image files that have not been printed. Code:xxxx	Turn off the printer, and then start it again. If the error persists, a malfunction may have occurred. Contact Epson Product Support .

Troubleshooting

Code	Message	What to do
W-5201	<p>The paper set in Print Settings and the paper loaded in the printer differ.</p> <p>After replacing the paper, click [OK]. If printing is currently being performed, when printing has stopped, replace the paper, and then click [OK].</p> <p>To continue printing using the current settings, click [Print].</p>	<p>Load the appropriate paper. After replacing the paper, set the Paper Type and the Paper Level in the Maintenance Tool.</p> <p>See "Replacing Paper" on page 25</p> <p>To continue printing with the current settings, click Print.</p>
W-2206	<p>You have not installed genuine Epson ink cartridges.</p> <p>Information about ink levels may not be displayed, and use of non-genuine ink is recorded for possible use in service support.</p> <p>For optimum quality and reliability Epson recommends using genuine Epson ink.</p> <p>Do you want to continue?</p> <p>Please call Epson user service hot-line 400-810-9977 for genuine I/C purchase.</p>	<p>This printer is developed for use with genuine ink cartridges. If you use non-genuine cartridges, the print result may be faint, or the ink remaining may not be detected normally. We recommend using genuine Epson products.</p>
E-5201	<p>Failed to acquire printing calibration data.</p> <p>Check that the cable is connected, and then turn the printer back on.</p> <p>Contact service support if the error continues to occur.</p>	<p>Turn off the printer, and then start it again.</p> <p>If the error persists, contact Epson Product Support .</p>
I-5201, W-5202	<p>Amount of data in print jobs sent to printer nearly at maximum limit.</p> <p>Stop sending the current print job and send the remaining pages as another print job.</p>	<p>The print job is too large.</p> <p>After deleting all of the print jobs, split up the data, and then try printing again.</p>

Troubleshooting

Errors and Solutions (Mac)

Check the details of the error displayed, and then take the necessary measures.

Code	Message	What to do
W-2301 to W-2303 W-2305 to W-2306	Cannot perform [Detect Clogging] correctly. Delete all print jobs remaining in the operating system's print queue. Perform [Diagnostic Cleaning]. Contact service support if the error continues to occur.	After deleting all of the print jobs, perform Diagnostic Cleaning in the Maintenance Tool. See the "Maintenance Tool Operation Guide" for more details on the Maintenance Tool. If "Auto nozzle check failed." is displayed on the screen, contact Epson Product Support .
I-2307	Cannot perform [Detect Clogging] correctly. Room temperature may not be within the guaranteed operating range. Check the room temperature.	Check the room temperature. Use within the recommended operating temperature range.
W-2311	Clogged nozzle(s) detected. Delete all print jobs remaining in the operating system's print queue. Perform [Diagnostic Cleaning].	After deleting all of the print jobs, perform Diagnostic Cleaning in the Maintenance Tool. See the "Maintenance Tool Operation Guide" for more details on the Maintenance Tool.
I-2401	Replace the maintenance cartridge soon Prepare a new maintenance cartridge(XXXX). You may continue printing until replacement of the maintenance cartridge is required.	Check the message, and then click OK . Prepare a new maintenance cartridge with the model number displayed in XXXX. See "Replacing the Maintenance Cartridge" on page 56
I-2201	Ink Low (XXXX) Prepare a new ink cartridge. You may continue printing until replacement of the ink cartridge is required. Epson recommends the genuine Epson cartridges listed above.	Check the message, and then click OK . Prepare a new ink cartridge for the color and model number displayed in XXXX, and then get ready to replace the cartridge. See "Replacing Ink Cartridges" on page 48
I-2101 to I-2104	It is nearly time to replace parts. XXXXXX Contact a technical representative. You cannot print if parts have reached the end of their service life.	Contact Epson Product Support and request replacement for the part displayed in XXXXXX.
W-1301	The scrap paper box has come off. Delete all print jobs remaining in the operating system's print queue. Install the scrap paper box correctly.	After deleting all of the print jobs, attach the scrap paper box. If a message is displayed, check the details.

Troubleshooting

Code	Message	What to do
W-1302	<p>Cartridge cover (right) open.</p> <p>Delete all print jobs remaining in the operating system's print queue.</p> <p>When replacing a cartridge, check the location and the cartridge type.</p> <p>Close the cartridge cover.</p>	<p>After deleting all of the print jobs, close the cartridge cover (right). If a message is displayed, check the details.</p>
W-1303	<p>Cartridge cover (left) open.</p> <p>Delete all print jobs remaining in the operating system's print queue.</p> <p>When replacing a cartridge, check the location and the cartridge type.</p> <p>Close the cartridge cover.</p>	<p>After deleting all of the print jobs, close the cartridge cover (left). If a message is displayed, check the details.</p>
W-1304	<p>Top cover open.</p> <p>Delete all print jobs remaining in the operating system's print queue.</p> <p>Close the top cover.</p>	<p>After deleting all of the print jobs, close the top cover. If a message is displayed, check the details.</p>
W-1305	<p>Rear cover open.</p> <p>Delete all print jobs remaining in the operating system's print queue.</p> <p>Close the rear cover.</p>	<p>After deleting all of the print jobs, close the rear cover. If a message is displayed, check the details.</p>
I-1311	<p>Check the scrap paper box.</p> <p>Empty the box if it is full.</p>	<p>Check the scrap paper box. Check the scrap paper box, and empty it if it is full.</p> <p>See "Emptying the Scrap Paper Box" on page 61</p>
W-1101	<p>A paper jam has occurred.</p> <p>Delete all print jobs remaining in the operating system's print queue.</p> <p>Remove any paper remaining from the roll paper feeder, and then reload the paper.</p>	<p>After deleting all of the print jobs, remove the paper from the roll paper feeder, and then reload the paper.</p> <p>See "Paper Jams" on page 84</p>
W-1102	<p>A paper jam has occurred.</p> <p>Delete all print jobs remaining in the operating system's print queue.</p> <p>Open the rear cover and the top cover, remove any paper remaining, and then reload the paper.</p>	<p>After deleting all of the print jobs, remove the paper from the internal paper feeder, and then reload the paper.</p> <p>If the printer is setup so that you cannot access the rear of the printer to perform maintenance, contact Epson Product Support .</p> <p>See "Paper Jams" on page 84</p>
W-1103	<p>An error has occurred in the paper feeding unit.</p> <p>Delete all print jobs remaining in the operating system's print queue.</p> <p>Reload the paper in the same way as when replacing paper.</p>	<p>After deleting all of the print jobs, check that there is no paper inside the printer, and then reload the paper. If a message is displayed, check the details.</p> <p>See "Replacing Paper" on page 25</p>

Troubleshooting

Code	Message	What to do
W-1104	<p>Paper is not loaded correctly.</p> <p>Delete all print jobs remaining in the operating system's print queue.</p> <p>Check the positions of the edge guides, and then reload the paper.</p>	<p>After deleting all of the print jobs, check that there is no paper inside the printer, and then reload the paper.</p> <p>When loading the paper, match the inner edge guide and the front edge guide to the width of the paper. If a message is displayed, check the details.</p> <p>See "Replacing Paper" on page 25</p>
W-1105	<p>Paper is out.</p> <p>Delete all print jobs remaining in the operating system's print queue.</p> <p>Load paper.</p>	<p>After deleting all of the print jobs, check that there is no paper inside the printer, and then reload the paper. If a message is displayed, check the details.</p>
W-1106	<p>Paper is out or not loaded correctly.</p> <p>Delete all print jobs remaining in the operating system's print queue.</p> <p>Load paper.</p>	<p>See "Replacing Paper" on page 25</p>
W-1108	<p>The width of the loaded paper is not supported.</p> <p>Delete all print jobs remaining in the operating system's print queue.</p> <p>Load supported paper.</p>	<p>After deleting all of the print jobs, load the appropriate paper.</p> <p>See "Replacing Paper" on page 25</p>
W-1109	<p>Cannot recognize the paper type.</p> <p>Delete all print jobs remaining in the operating system's print queue.</p> <p>Update the paper information.</p>	<p>Update the paper information. See the "Maintenance Tool Operation Guide" for more details on updating the information.</p>
W-2101 to W-2104	<p>Parts have reached the end of their service life.</p> <p>xxxxxx</p> <p>Do you want to continue using the printer or replace parts?</p> <p>Delete all print jobs remaining in the operating system's print queue.</p> <p>If you continue to use the printer, ink could leak or a malfunction could occur.</p> <p>Do you want to continue?</p>	<p>Contact Epson Product Support and request replacement for the part displayed in xxxxxx.</p>
W-2401	<p>Maintenance cartridge not installed</p> <p>Delete all print jobs remaining in the operating system's print queue.</p> <p>Install the maintenance cartridge.</p>	<p>After deleting all of the print jobs, install the maintenance cartridge correctly.</p> <p>See "Replacing the Maintenance Cartridge" on page 56</p>
W-2402	<p>Maintenance cartridge usage exceeded the application limit.</p> <p>Delete all print jobs remaining in the operating system's print queue.</p> <p>Replace the maintenance cartridge(xxxx).</p>	<p>After deleting all of the print jobs, replace the maintenance cartridge with the model number displayed in xxxx.</p> <p>See "Replacing the Maintenance Cartridge" on page 56</p>

Troubleshooting

Code	Message	What to do
W-2201	<p>Ink cartridge error (xxxx)</p> <p>Delete all print jobs remaining in the operating system's print queue. Please install correct cartridge.</p> <p>Epson recommends the genuine Epson cartridges listed above.</p>	<p>After deleting all of the print jobs, check the ink cartridge with the color displayed in xxxx, and then replace the cartridge.</p> <p>If a message is displayed, check the details.</p> <p>See "Replacing Ink Cartridges" on page 48</p>
W-2202	<p>Replace Cartridge (xxxx)</p> <p>Delete all print jobs remaining in the operating system's print queue. Epson recommends the genuine Epson cartridges listed above.</p>	<p>After deleting all of the print jobs, check the ink cartridge with the color and model number displayed in xxxx, and then replace the cartridge.</p> <p>If a message is displayed, check the details.</p> <p>See "Replacing Ink Cartridges" on page 48</p>
W-2203	<p>Ink cartridge error (xxxx)</p> <p>Delete all print jobs remaining in the operating system's print queue. Remove and reinstall them correctly or replace them. Epson recommends the genuine Epson cartridges listed above.</p>	<p>After deleting all of the print jobs, check the ink cartridge with the color and model number displayed in xxxx, and then replace the cartridge or reinstall it correctly.</p> <p>If a message is displayed, check the details.</p> <p>See "Replacing Ink Cartridges" on page 48</p>
W-2204	<p>Ink cartridge error (xxxx)</p> <p>Delete all print jobs remaining in the operating system's print queue. Please install correct cartridge.</p> <p>Epson recommends the genuine Epson cartridges listed above.</p>	<p>After deleting all of the print jobs, check the ink cartridge with the color and model number displayed in xxxx, and then replace the cartridge.</p> <p>If a message is displayed, check the details.</p> <p>See "Replacing Ink Cartridges" on page 48</p>
W-2205	<p>Insufficient ink left to perform head cleaning or initial charge. Replace the ink cartridge indicated by the ink light that is turned on. Delete all print jobs remaining in the operating system's print queue. The cartridge being used can be installed again for printing.</p>	<p>Replace the ink cartridge for which the ink light is on, and then delete all print jobs.</p> <p>If a message is displayed, check the details.</p> <p>See "Replacing Ink Cartridges" on page 48</p>
W-2403	<p>Maintenance cartridge cannot be recognized Delete all print jobs remaining in the operating system's print queue. Install the maintenance cartridge correctly.</p>	<p>After deleting all of the print jobs, replace the maintenance cartridge or reinstall it correctly.</p> <p>If a message is displayed, check the details.</p> <p>See "Replacing the Maintenance Tank" on page 56</p>

Troubleshooting

Code	Message	What to do
W-2404	<p>Insufficient free space in the maintenance cartridge.</p> <p>Delete all print jobs remaining in the operating system's print queue.</p> <p>Replace the maintenance cartridge (xxxx), and then perform head cleaning or initial charge.</p>	<p>After deleting all of the print jobs, replace the maintenance cartridge.</p> <p>If a message is displayed, check the details.</p> <p>See "Replacing the Maintenance Tank" on page 56</p>
E-5101	<p>The printer is disconnected.</p> <p>Delete all print jobs remaining in the operating system's print queue.</p> <p>Check that the cable is connected, and then turn the printer back on.</p> <p>Contact service support if the error continues to occur.</p>	<p>After deleting all of the print jobs, check that the cables are connected correctly, and then restart the printer.</p> <p>If the error persists, contact Epson Product Support</p>
E-2101 to E-2104	<p>Parts have reached the end of their service life.</p> <p>xxxxxx</p> <p>Contact a technical representative.</p> <p>Delete all print jobs remaining in the operating system's print queue.</p>	<p>After deleting all of the print jobs, contact Epson Product Support and request replacement for the part displayed in xxxxxx.</p>
E-9901 (xxxx), E-9902 (xxxx)	<p>A printer system error occurred.</p> <p>Delete all print jobs remaining in the operating system's print queue.</p> <p>Turn the printer off. Check if there is any paper remaining inside the printer, and then turn the printer back on.</p> <p>Contact service support if the error continues to occur.</p>	<p>After deleting all of the print jobs, restart the printer.</p> <p>If the error persists, a malfunction may have occurred. Contact Epson Product Support.</p>
I-5201	<p>Amount of data in print jobs sent to printer nearly at maximum limit.</p> <p>Stop sending the current print job and send the remaining pages as another print job.</p>	<p>The print job is too large.</p> <p>After deleting all of the print jobs, split up the data, and then try printing again.</p>
W-2206	<p>You have not installed genuine Epson ink cartridges.</p> <p>xxxx</p> <p>Information about ink levels may not be displayed, and use of non-genuine ink is recorded for possible use in service support.</p> <p>For optimum quality and reliability Epson recommends using genuine Epson ink.</p>	<p>This printer is developed for use with genuine ink cartridges. If you use non-genuine cartridges, the print result may be faint, or the ink remaining may not be detected normally. We recommend using genuine Epson products.</p>
W-2207	<p>A non-genuine or refilled cartridge has been detected. Ink levels may not be shown because of unknown ink volume.</p>	
W-2208	<p>A non-genuine or refilled cartridge has been detected. Ink levels may not be shown because of unknown ink volume.</p>	

Cannot Clear the Displayed Error

If an error is displayed that cannot be cleared, follow the steps below to restart the printer.

- 1 Check that the printer's  light is on. Press the power button to turn the power off (the light turns off).



If you cannot turn off the power using the button, unplug the power cable.



- 2 Reconnect the power cable, and then press the power button (the light turns on).
The  light turns on.



Troubleshooting

Note:

If the error persists even after restarting, contact Epson Product Support .

Paper Jams

This section explains how to clear paper jammed in the printer.

When a paper jam occurs, the **!** light on the front of the printer turns on, and the  light flashes.

See “Lights” on page 12

 light



The procedure differs for the roll paper feeder and the internal paper feeder. Check the error message to determine which procedure to use.

- W-1101 When the message "A paper jam has occurred. Delete all print jobs remaining in the operating system's print queue. Remove any paper remaining from the roll paper feeder, and then reload the paper." is displayed, check for paper jams in the roll paper feeder.
[See “Paper is Jammed in the Roll Paper Feeder” on page 86](#)
- W-1102 When the message "A paper jam has occurred. Delete all print jobs remaining in the operating system's print queue. Open the rear cover and the top cover, remove any paper remaining, and then reload the paper." is displayed, check for paper jams in the internal paper feeder.
[See “Paper is Jammed in the Internal Paper Feeder” on page 92](#)

 **Important:**

- Do not leave the printer with a paper jam. Fire could ignite or smoke could be emitted.*
- When a printer system error occurs, if the error persists after restarting the printer, check if a paper jam has occurred.*
- Do not remove the paper forcibly when clearing paper jams. Otherwise, the printer could be damaged.*

Deleting Print Jobs

Before starting operations on Mac, delete all jobs from the print queue.

Mac

- 1 Click the printer icon in the Dock.



- 2 Select the job you want to cancel, and then click [x] (or **Delete**).

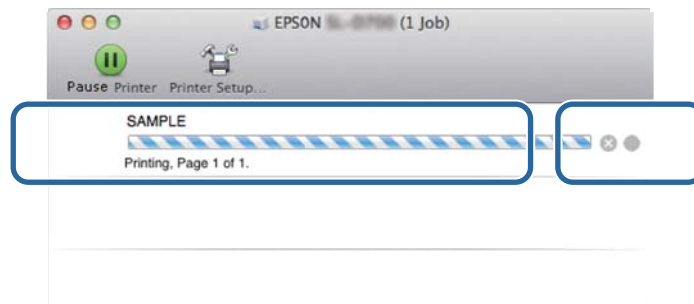

Paper is Jammed in the Roll Paper Feeder

Error message W-1101 - When the message "Remove any paper remaining from the roll paper feeder, and then reload the paper. " is displayed, follow the steps below.

1 For Mac, delete all jobs from the print queue.

2 Remove the scrap paper box.

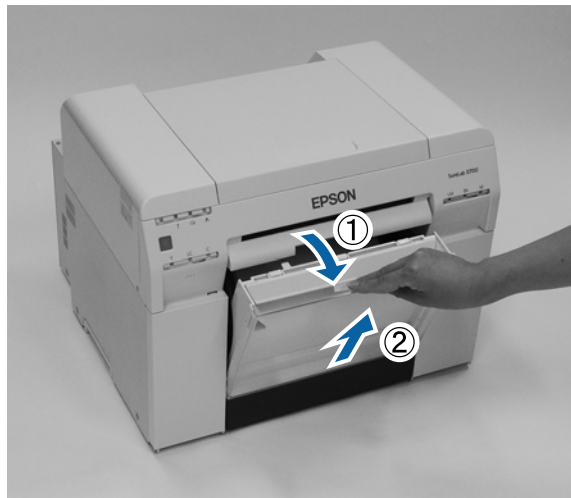

3 Grip the handle to release the roll paper feeder and then pull it out.

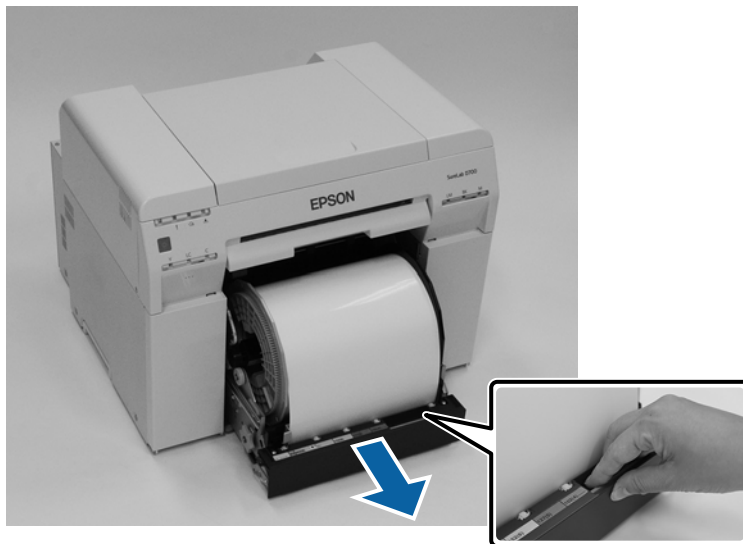

Troubleshooting

! **Important:**

If you cannot remove the roll paper feeder for some reason, do not try to pull it out by force. Paper may be jammed inside. When you can access the top and rear of the printer, remove the paper by following the procedure in the next section "Paper is Jammed in the Internal Paper Feeder".

See "Paper is Jammed inside the Printer" on page 92

Contact your local dealer if you cannot access the top or rear of the printer.

- 4** Turn the knob on the left of the roll paper feeder counter clockwise until the leading edges releases from the paper feed slot.

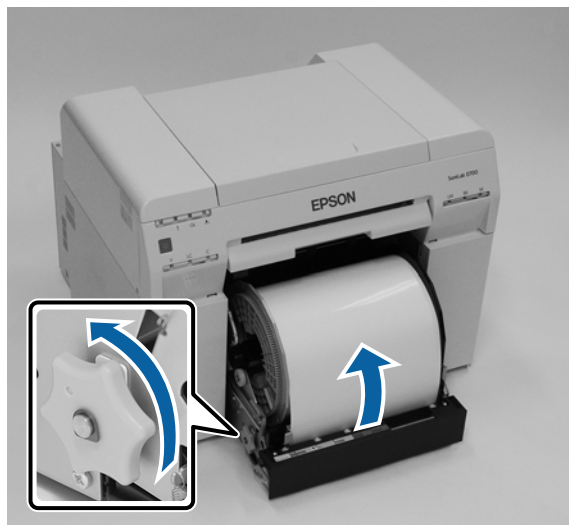

- 5** If the leading edge of the paper is ragged, cut it in a straight line with a pair of scissors. Cut the paper as straight as possible.



Troubleshooting

- 6 Remove the roll paper spindle.

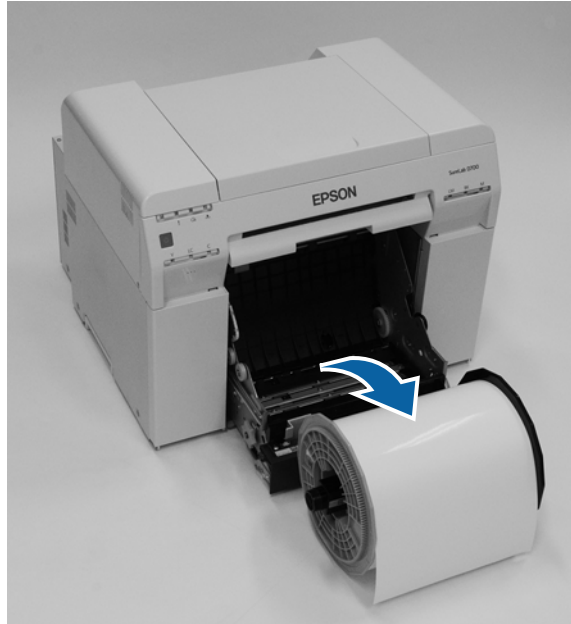

- 7 Lift the rear plate.

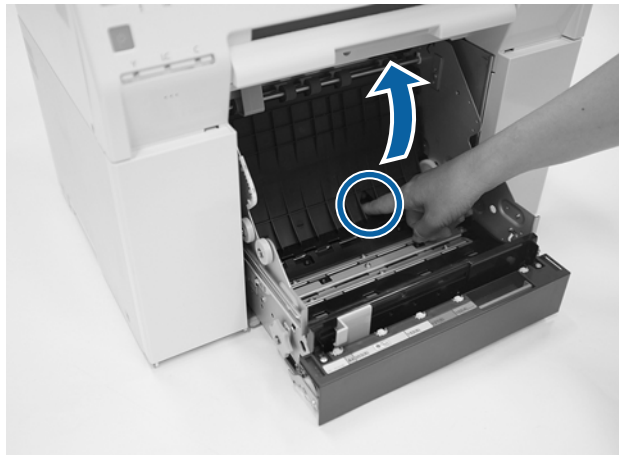

Troubleshooting

- 8** Check that there is no paper or foreign material inside of the printer.
If there is a jam, remove the paper slowly.

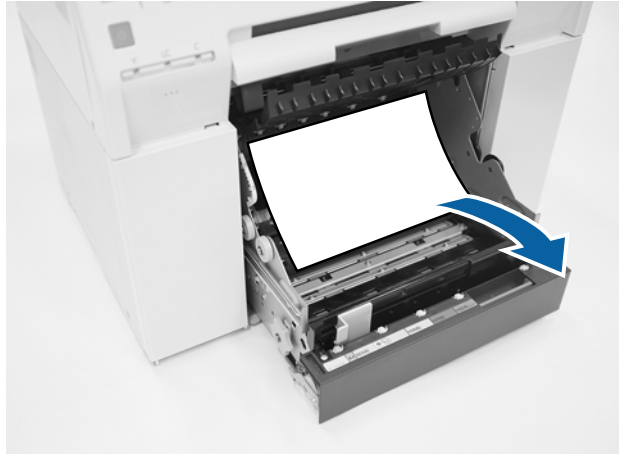

- 9** Lift the front plate.

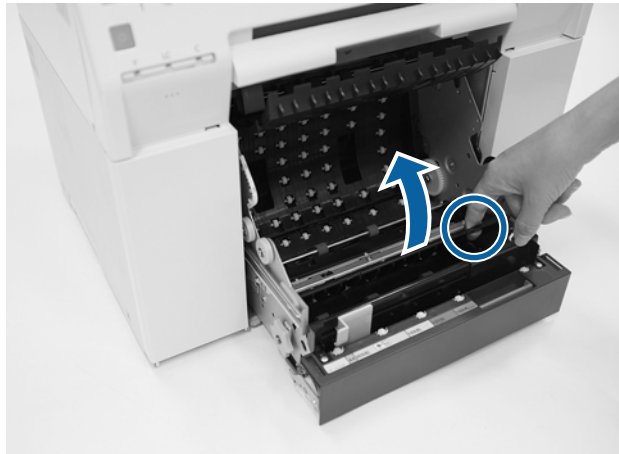

- 10** Check that there is no paper, foreign material, or scrap paper at the back of the printer.
If there is a jam, remove the paper slowly.

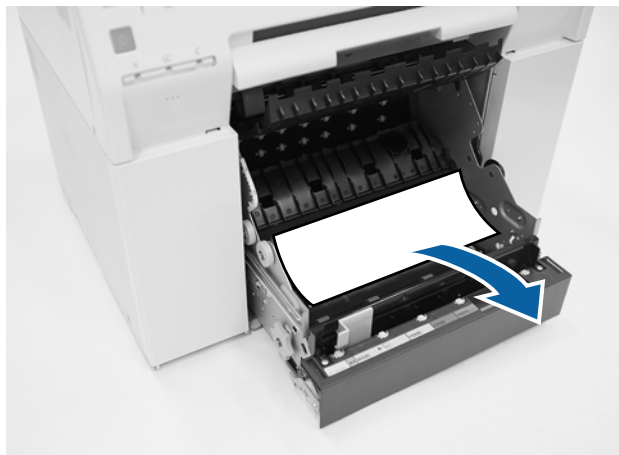

Troubleshooting

- 11 Lower the front plate and press down until you hear it click into place. Repeat this for the rear plate.

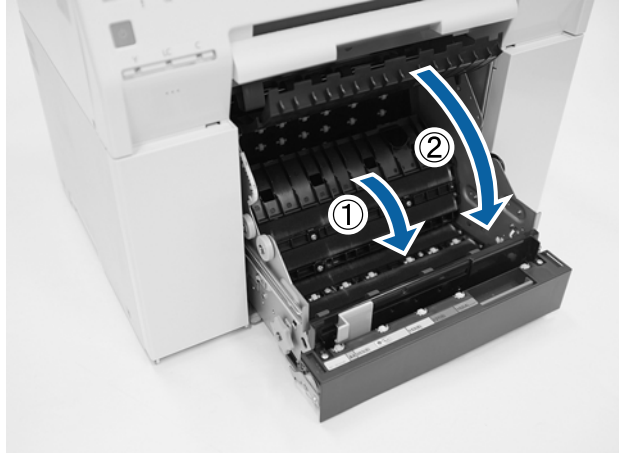

- 12 Reload the paper.
Make sure the leading edge is cut straight across to avoid paper feeding problems.
[See “Replacing Paper” on page 25](#)

- 13 If an error message is still displayed on a Windows computer's screen, click **OK** to close the screen.

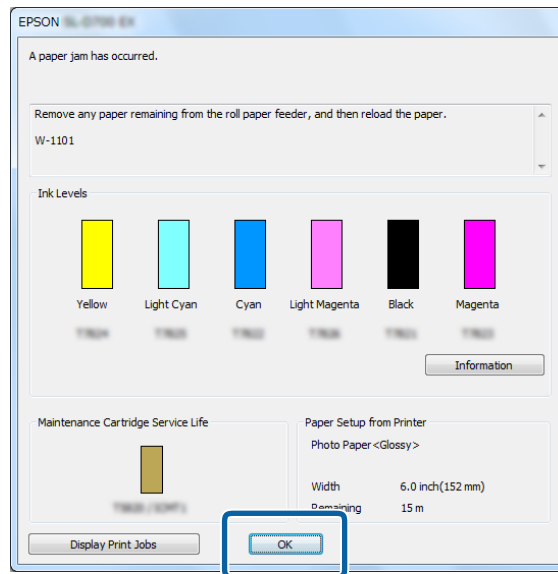

Troubleshooting

- 14 Check that the ! light turns off, and the ⏻ light is lit and isn't flashing.



Paper is Jammed Inside the Printer

Error message W-1102 - When the message "Open the rear cover and the top cover, remove any paper remaining, and then reload the paper." is displayed, follow the steps below.

If you have cleared a paper jam from the roll paper feeder but the error is still not cleared, or you cannot pull out the roll paper feeder, there may be a jam inside the printer.

! **Important:**

Contact your local dealer if you cannot access the top or rear of the printer.

1 For Mac, delete all jobs from the print queue.

2 Remove the scrap paper box.

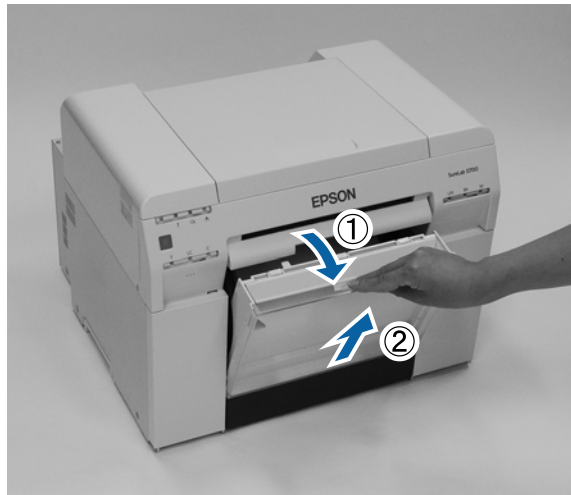

3 Squeeze the lock lever on the back to release the lock, and then open the rear cover.

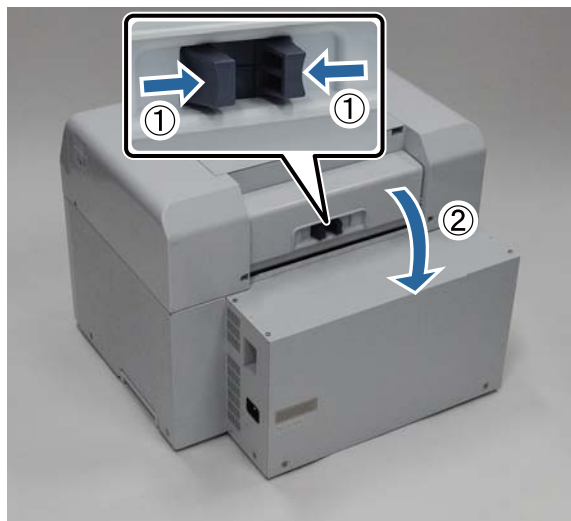

Troubleshooting

- 4 Open the top cover.
Check the point where the jam occurred.



- 5 If paper is caught in the the front of the printer, cut the paper in front of the jam with a pair of scissors.

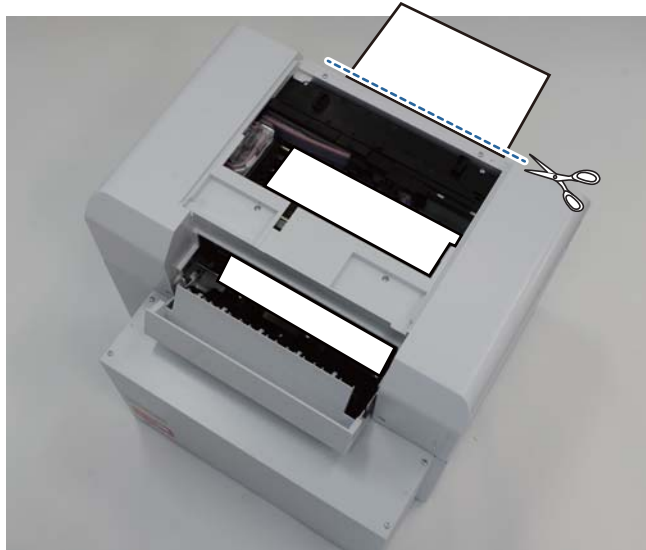

Troubleshooting

6

Slowly pull the remaining paper towards the back of the printer.

If you successfully pull out the paper, go to step 8.

If the paper is caught under the print head and cannot be easily removed, go to step 7.

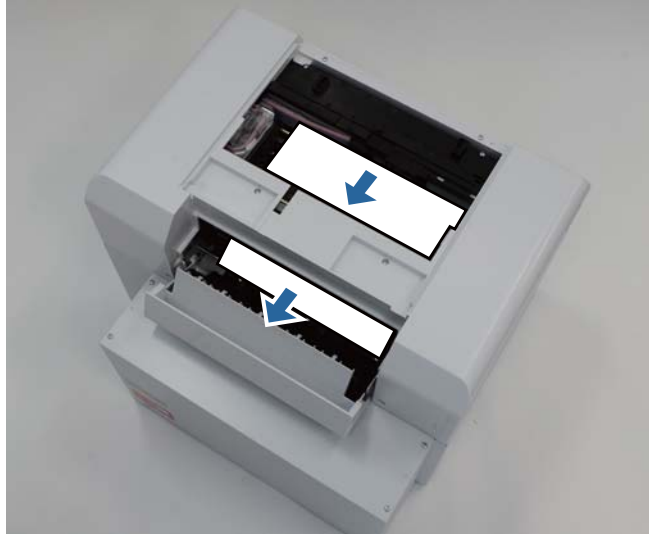

7

Move the print head manually, and remove the paper from the back of the printer.

Make sure to move the print head away from the paper (for example, if the paper is on the right, move the print head to the left).



Troubleshooting

! *Important:*

- ❑ *If you cannot move the print head unit, do not try to force it to move, contact Epson support. Otherwise, the print head unit could be damaged.*
- ❑ *When removing the paper, do not touch the ink absorbing areas.*

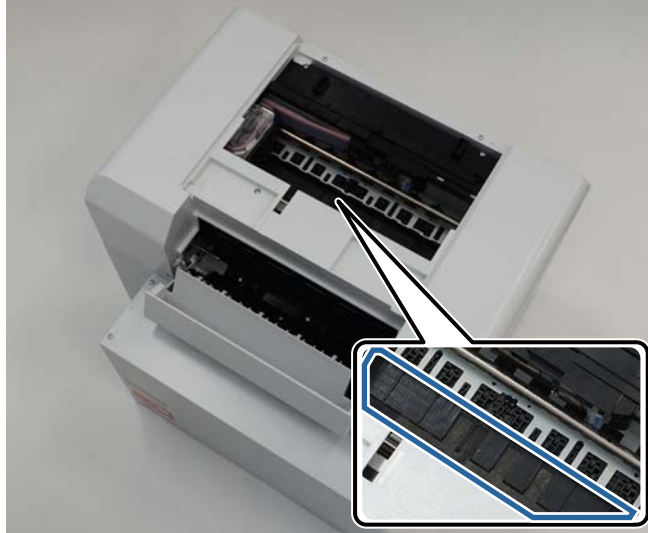

8

Cut the paper you have pulled out with scissors.



! *Important:*

After cutting the paper, do not pull the paper inside the printer to the upper section.

Troubleshooting

- 9 Close the top cover.

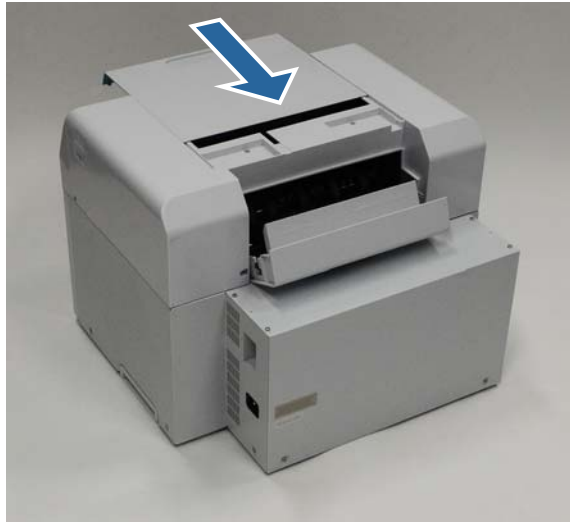

- 10 Check if there is a paper jam in the roll paper feeder.
Perform steps 2 to 11 in "Paper is Jammed in the Roll Paper Feeder".
See ["Paper is Jammed in the Roll Paper Feeder" on page 86](#)

- 11 Close the rear cover.



- 12 Remove the roll paper spindle from the printer and reload it.
See ["Replacing Paper" on page 25](#)

Troubleshooting

13

If an error message is still displayed on a Windows computer's screen, click **OK** to close the screen.

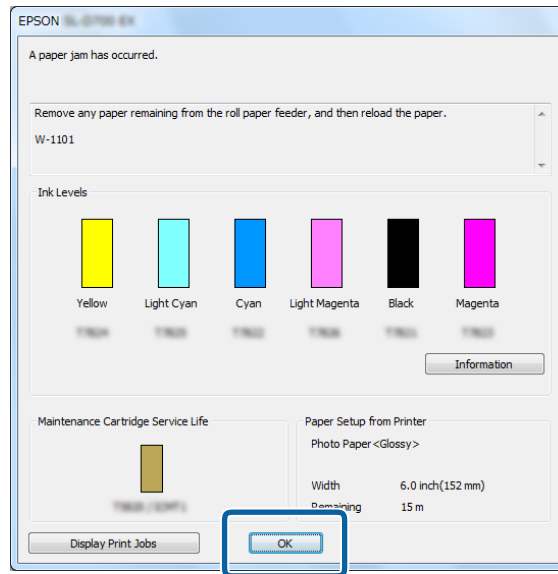

14

Check that the ! light turns off, and the ⏻ light is lit and isn't flashing.

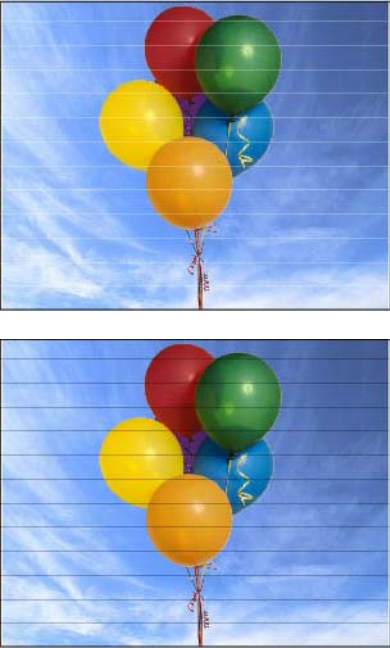

Problems with Print Results

Cause	What to do
<p>Stripes appear at regular intervals in the print outs.</p> 	<p>Are the print head unit nozzles clogged? If the print head unit is clogged, stripes appear at regular intervals, and print quality declines. Check the nozzle status in the Maintenance Tool, and then try cleaning.</p> <p>See the "Maintenance Tool Operation Guide" for more details on the Maintenance Tool.</p>
<p>Print quality is poor, uneven, too light, or too dark.</p>	<p>Are the print head unit nozzles clogged? If the nozzles in the print head unit are clogged, specific nozzles do not fire ink and the print quality declines. Check the nozzle status in the Maintenance Tool, and then try cleaning.</p> <p>See the "Maintenance Tool Operation Guide" for more details on the Maintenance Tool.</p> <p>Are you using a genuine ink cartridge? This printer is developed for use with genuine ink cartridges. If you use non-genuine ink cartridges, the prints may smear, or the color of the printed image may be changed because the remaining ink level is not correctly detected. Be sure to use the correct ink cartridge.</p> <p>Are you using an old ink cartridge? The print quality declines when an old ink cartridge is used. Replace the old ink cartridge with a new one. We recommend using all the ink in the ink cartridge before the expiry date printed on the package (within six months of installation).</p> <p>See "Replacing Ink Cartridges" on page 48</p> <p>Do the settings in the Maintenance Tool and the settings in the printer driver match the paper loaded in the printer? If the loaded paper type and the set Paper Type differ, print quality may decline. Check the settings.</p> <p>See "Changing Paper Settings" on page 38</p> <p>Have you compared the print result with the image on the display monitor? Since monitors and printers produce colors differently, printed colors will not always match on-screen colors perfectly.</p>

Troubleshooting

Cause	What to do
The printed surface is scuffed or soiled.	Is the paper too thick or too thin? Check that the paper can be used with this printer. See "Printer Specifications" on page 103
The back of the printed paper is dirty.	Is there paper powder on the platen? Clean the platen. See "Cleaning the Platen" on page 63
The paper is creased.	Are you using the printer at normal room temperature? The printer should be used at normal room temperature (temperature: 59 to 77°F (15 to 25 C), humidity: 40 to 60 %). For information about paper such as thin paper from other manufacturers that requires special handling, see the documentation supplied with the paper

Problems when Cutting Paper

Cause	What to do
The cut is crooked, the cut edge is frayed or turned up, or the coating is cracked.	The cutter needs to be replaced. Contact Epson Product Support to request cutter replacement.

When a Problem Cannot be Cleared

If you cannot resolve a problem after taking the measures described in the "Troubleshooting" section, contact Epson Product Support

Appendix

Consumables and Optional Items

The following consumable products and optional items are available for use with your printer. (As of April, 2019)

Ink cartridges

This printer is developed for use with genuine ink cartridges.

If you use non-genuine cartridges, the print result may be faint, or the ink remaining may not be detected normally.

Model name	Ink color	Product number
SL-D800	Black	T43U1
	Cyan	T43U2
	Magenta	T43U3
	Yellow	T43U4
	Light Cyan	T43U5
	Light Magenta	T43U6
SL-D830	Black	T43Y1
	Cyan	T43Y2
	Magenta	T43Y3
	Yellow	T43Y4
	Light Cyan	T43Y5
	Light Magenta	T43Y6
SL-D860	Black	T43X1
	Cyan	T43X2
	Magenta	T43X3
	Yellow	T43X4
	Light Cyan	T43X5
	Light Magenta	T43X6

Appendix

Model name	Ink color	Product number
SL-D870	Black	T43S120
	Cyan	T43S220
	Magenta	T43S320
	Yellow	T43S420
	Light Cyan	T43S520
	Light Magenta	T43S620

Others

Product name	Product number	Explanation
MAINTENANCE CARTRIDGE	T5820000	Absorbs ink consumed during head cleaning. See "Replacing the Maintenance Cartridge" on page 56
ROLL PAPER SPINDLE	C12C934881	The same as the roll paper spindle supplied with the printer. Remove the tape before use.
PRINT TRAY	C12C891171	This tray holds print outs that are 102 mm or less.
LARGE PRINT TRAY	C12C934781	This tray holds print outs.

Notes on Moving the Printer

Perform the following operations when moving the printer.



Caution:

- When lifting this printer, make sure you use the correct posture.
- When lifting the printer, hold it in the areas indicated in the manual. The printer may fall if you lift it by holding other areas, and your fingers could be caught which may cause an injury.

Appendix

Place your hands at the points indicated in the photo, and then lift.

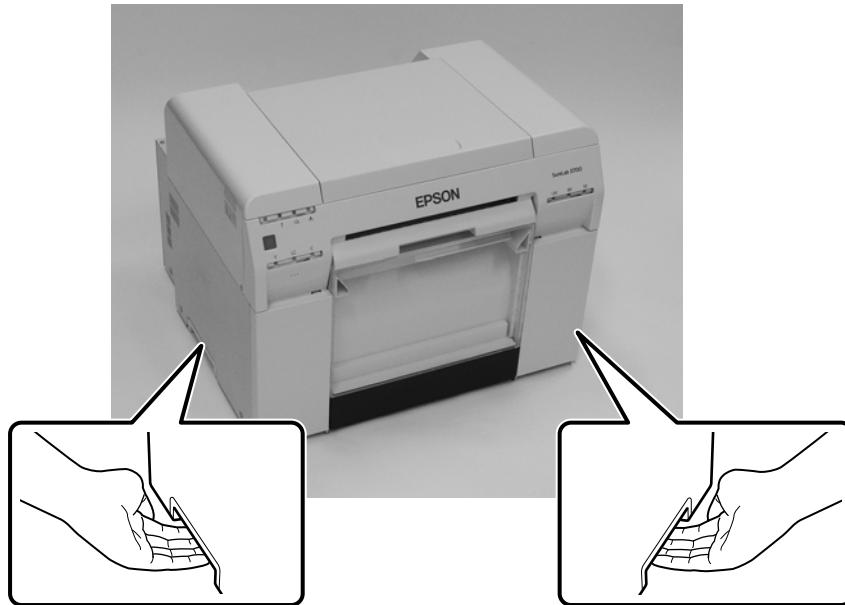

Important:

- Only hold the required area. Otherwise, it may breakdown.
- Move the printer with ink cartridges installed. Do not remove the ink cartridges; otherwise, the nozzles may be clogged and make it impossible to print, or ink may leak.
- When moving the printer, do not tilt it. Ink could leak out.

Preparing to Move

Make the following preparations in advance before moving the printer.

- Turn off the printer and remove all cables.
- Remove any trays if they are installed.
- Remove any paper.

After Moving

After moving, make sure that the print head is not clogged before use.

See "Maintenance Tool Operation Guide"

Printer Specifications

Basic specifications	
Printing method	On-demand ink jet
Nozzle configuration	180 nozzles for each color
Print direction	Bidirectional printing
Highest resolution	1440 x 720 dpi
Paper feed method	Friction feed
Interface	Universal Serial Bus Specifications Revision 2.0

Important:

Use this printer at an altitude of up to 6500 feet (2000 m).

Electrical Specifications		
Rated voltage	AC 100 to 120 V	AC 220 to 240 V
Rated frequency range	50/60 Hz	50/60 Hz
Rated current	3.0 A	1.5 A
Power consumption	Operating: Approximately 140 W When standing by: Approximately 60 W Sleep mode: Approximately 6 W Power off: Less than 0.5 W	Operating: Approximately 140 W When standing by: Approximately 60 W Sleep mode: Approximately 6 W Power off: Less than 0.5 W

Paper Feeder Specifications	
Paper core size	Roll paper feeder (3-inch core diameter): Outer diameter less than 6.7 inches (170 mm)
Paper length	2 to 39.3 inches (50 to 1000 mm)
Paper width	3.5 inches (89 mm), 4 inches (102 mm), 5 inches (127 mm), 6 inches (152 mm), 8 inches (203 mm), 8.3 inches (210 mm)

Ink Specifications	
Type	Ink cartridges
Ink type	Six-color water-based dye
Use by date	Three years after manufacture
Storage temperature	In the packaging: -4 to 104°F (-20 to 40°C) (within one month at 104°F (40°C)) Installed in printer: -4 to 104°F (-20 to 40°C) (within one month at 104°F (40°C)) Transport: -5 to 140°F (-20 to 60°C) (within one month at 104°F (40°C), 72 hours at 140°F (-60°C))
Capacity	200 mL

Appendix

Ink Specifications	
Cartridge dimensions	1 (W) x 7.9 (D) x 3.9 (H) inches (25 (W) x 200 (D) x 100 (H) mm)



Important:

- The ink freezes if left at below 5°F (-15°C) for a long time. If it does freeze, leave it at room temperature (77°F (25°C)) for at least four hours until it has defrosted (without condensation).*
- Do not disassemble the ink cartridges or refill the ink.*

Maintenance Cartridge Specifications	
Type	Maintenance cartridge for waste ink
Number installed	1
Environmental conditions	In the packaging: -4 to 104°F (-20 to 40°C) (temperature), 20 to 85% (humidity) Installed in printer: Conforms to the general specifications below Transporting: -4 to 140°F (-20 to 60°C) (temperature) 5 to 85% (humidity) (within one month at 104°F (40°C), 120 hours at 140°F (60°C))
Cartridge dimensions	3.1 (W) x 10 (D) x 1.5 (H) inches (78.8 (W) x 254.5 (D) x 38.5 (H) mm)

General Specifications	
Temperature	Operating: 50 to 95°F (10 to 35°C) Storage (before unpacking): -4 to 140°F (-20 to 60°C) (within 120 hours at 140°F (60°C), one month at 104°F (40°C)) Storage (after unpacking): -4 to 104°F (-20 to 40°C) (within one month at 104°F (40°C))
Humidity	Operating: 20 to 80% (without condensation) Storage (before unpacking): 5 to 85% (without condensation) Storage (after unpacking): 5 to 85% (without condensation)
Weight	Approx. 50.7 pounds (23 kg) (printer only)
Dimensions	18.1 (W) x 16.9 (D) x 13.9 (H) inches (460 (W) x 430 (D) x 354 (H) mm) See "Necessary space" on page 105

Standards and Approvals

Safety	UL 60950-1	
	CAN/CSA No. 60950-1	
	Low Voltage Directive 2014/35/EU	EN 62368-1

Appendix

EMC	FCC part 15 subpart B class A	
	ICES-003 Class A	
	AS/NZS CISPR 32 Class A	
	EMC Directive 2014/30/EU	EN55032 Class A
		EN 55024
		EN 61000-3-2
		EN 61000-3-3

⚠ Warning:

This is a class A product. In a domestic environment this product may cause radio interference in which case the user may be required to take adequate measures.

Necessary space

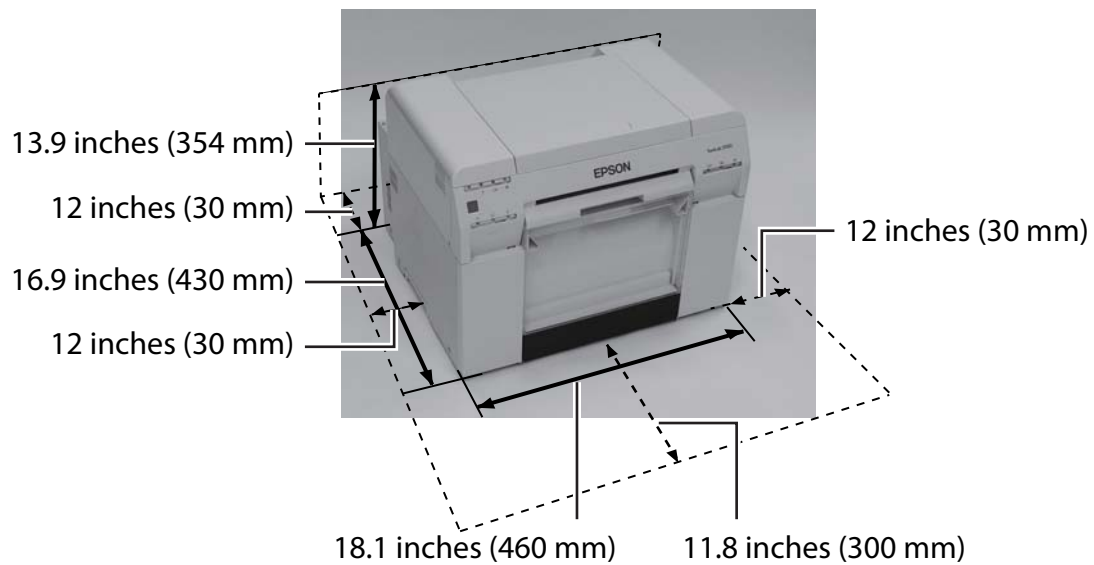

Notes

- ❑ Unauthorized reproduction of a part or all of this manual is strictly prohibited.
- ❑ The contents of this manual are subject to change without prior notice.
- ❑ Contact our company if you have any questions, find a mistake, or encounter a missing description, in the contents of this manual.
- ❑ Regardless of the previous point, we will under no conditions be liable for any damages or losses resulting from operation of this product.
- ❑ We will under no conditions be liable for any damages or losses resulting from operation of this product in any way other than described in this manual, inappropriate use of this product, or repairs or modifications performed by a third party other than our company or our suppliers.
- ❑ We are unable to accept responsibility for any problems resulting from the use of options or consumable products other than our genuine products, or products that we recommend, even if the problem occurs within the warranty period. In this case, a fee will be required for any necessary repairs.

FCC Compliance Statement

For United States Users

NOTE: This equipment has been tested and found to comply with the limits for a Class A digital device, pursuant to Part 15 of the FCC Rules. These limits are designed to provide reasonable protection against harmful interference when the equipment is operated in a commercial environment. This equipment generates, uses, and can radiate radio frequency energy and, if not installed and used in accordance with the instruction manual, may cause harmful interference to radio communications. Operation of this equipment in a residential area is likely to cause harmful interference in which case the user will be required to correct the interference at his own expense.

For European customers only

The crossed out wheeled bin label that can be found on your product indicates that this product should not be disposed of via the normal household waste stream. To prevent possible harm to the environment or human health please separate this product from other waste streams to ensure that it can be recycled in an environmentally sound manner. For more details on available collection facilities please contact your local government office or the retailer where you purchased this product.

This information only applies to customers in the European Union, according to Directive 2002/96/EC OF THE EUROPEAN PARLIAMENT AND OF THE COUNCIL OF 27 January 2003 on waste electrical and electronic equipment (WEEE) and legislation transposing and implementing it into the various national legal systems.

For other countries, please contact your local government to investigate the possibility of recycling your product.



Appendix

Indication of the manufacturer and the importer in accordance with requirements of directive 2011/65/EU (RoHS)

Manufacturer: SEIKO EPSON CORPORATION

Address: 3-5, Owa 3-chome, Suwa-shi, Nagano-ken 392-8502 Japan

Telephone: 81-266-52-3131

Importer: EPSON EUROPE B.V.

Address: Azie building, Atlas ArenA, Hoogoorddreef 5, 1101 BA Amsterdam Zuidoost The Netherlands

Telephone: 31-20-314-5000

CE Marking

Information of EU declaration of conformity: The full text of the EU declaration of conformity of this equipment is available at the following internet address. <https://www.epson.eu/conformity>

Where To Get Help

Internet Support

Visit Epson's support website at www.epson.com/support/D870 or www.epson.ca/support/D870 and select your product for solutions to common problems. You can download drivers and documentation, get FAQs and troubleshooting advice, or e-mail Epson with your questions.

Speak to a Support Representative

Epson provides technical support and information on installation, configuration, and operation of professional printing products through the Epson PreferredSM Limited Warranty Plan. Dial (888) 377-6611, 6 AM to 6 PM, Pacific Time, Monday through Friday. Days and hours of support are subject to change without notice.

Before you call Epson for support, please have the following information ready:

- Product name
- Product serial number
- Proof of purchase (such as a store receipt) and date of purchase
- Computer configuration
- Description of the problem

Note:

If you experience difficulty with the toll-free line, call (562) 276-1305.

Purchase Supplies and Accessories

You can purchase genuine Epson ink cartridges, maintenance cartridges, paper, and accessories from an Epson authorized reseller. To find the nearest reseller, call 800-GO-EPSON (800-463-7766). Or you can purchase online at <http://www.epsonstore.com> (U.S. sales) or <http://www.epson.ca> (Canadian sales).