

SUPERMICRO® SuperServer 510P-M/MR Quick Reference Guide

Board Layout

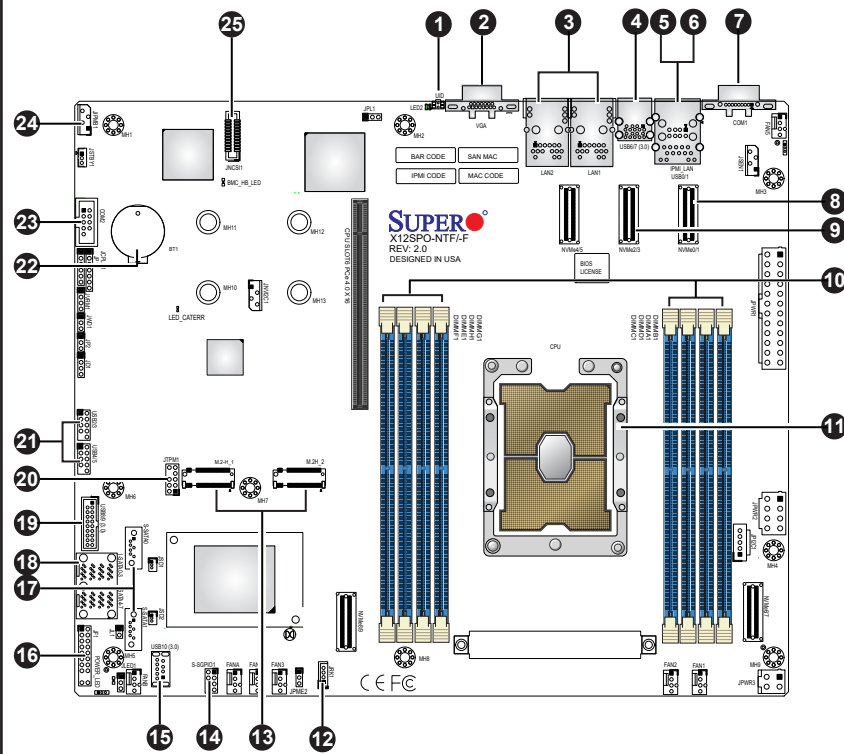

Item	Description
1	UID Button (Unit Identifier Button)
2	VGA Port
3	Two 1GbE LAN Ports
4	USB 3.2 Gen 1 Port
5	Dedicated LAN for IPMI
6	USB 2.0 Port
7	COM Port (Serial Port)
8	NVME0/1: PCI-E 4.0 x8 Slimline SAS Connector
9	NVME2/3: PCI-E 4.0 x8 Slimline SAS Connector
10	DIMM A1-H1 Slots
11	CPU
12	Intel RAID Key Header
13	M.2 PCI-E/SATA Interface

Item	Description
14	S-SGPIO Header
15	USB 3.2 Gen 1 Type A Port
16	Front Control Panel Header
17	S-SATA0-1: Internal SATA Ports
18	I-SATA0-7: Internal SATA Ports
19	USB 3.2 Gen 1 Header
20	TPM Header
21	USB 2.0 Header
22	Onboard CMOS Battery
23	COM Port Header (Serial Port)
24	JIPMB1 4-pin BMC External I2C Header
25	NC-SI Header for IPMI Support

Front View and Features

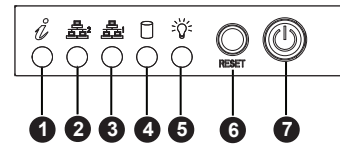
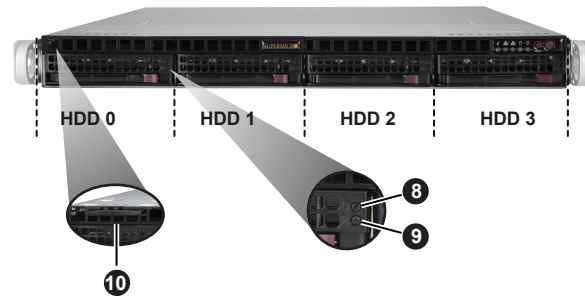

Control Panel Features	
Item	Description
1	Information LED
2	NIC2 LED
3	NIC1 LED
4	HDD LED
5	Power LED
6	Reset Button
7	Power Button
8	Drive Activity LED
9	Drive Status LED
10	Service/Asset Tag (pull-out identifier with BMC ADMIN default password underneath)

Rear View and Features

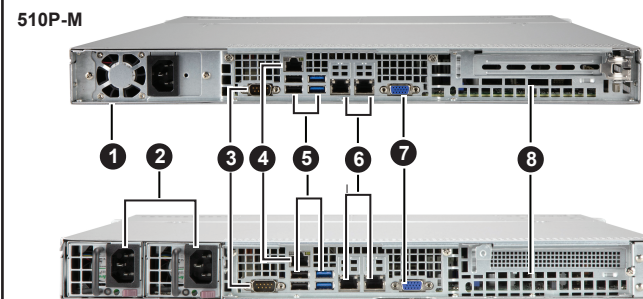

Item	Description
1	Single Power Supply Module
2	Redundant Power Supply Modules
3	Serial Port
4	Dedicated IPMI Port
5	Two USB 3.2 (blue) and Two USB 2.0 (black) Ports
6	LAN 1 (left) and LAN 2 (right) Ports
7	VGA Port
8	PCI-E 4.0 x16 Expansion Slot 1 (FHHL)

BMC Password Label

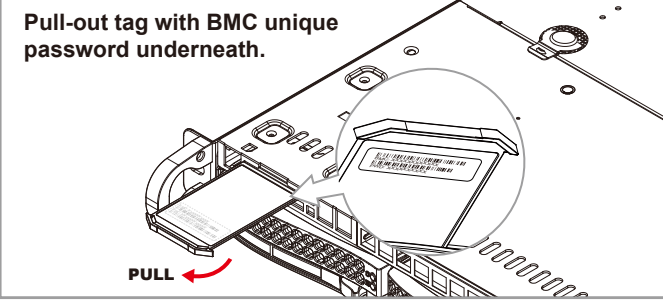

Each system comes with a unique default password for the ADMIN user. This can be found on a sticker on the motherboard and a sticker underneath the service tag on chassis. If necessary, the password can be reset by the Supermicro IPMICFG tool.

For more information, please visit <https://www.supermicro.com/en/solutions/management-software/bmc-resources>

Memory

DIMM Installation

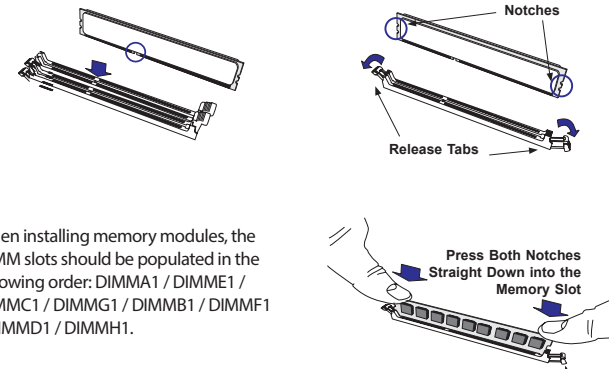

When installing memory modules, the DIMM slots should be populated in the following order: DIMMA1 / DIMME1 / DIMMC1 / DIMMG1 / DIMMB1 / DIMMF1 / DIMMD1 / DIMMH1.

- Always use DDR4 DIMM modules of the same type, size, and speed.
- Mixed DIMM speeds can be installed. However, all DIMMs will run at the speed of the slowest DIMM.
- The motherboard will support odd-numbered modules (3, 5, or 7 modules installed). However, to achieve the best memory performance, fully populated the motherboard with validated memory modules.

1 CPU, 8-DIMM Slots	
Number of DIMMs	Memory Population Sequence
1	DIMMA1
2	DIMMA1 / DIMME1
3	DIMMA1 / DIMME1 / DIMMC1
4	DIMMA1 / DIMME1 / DIMMC1 / DIMMG1
5	DIMMA1 / DIMME1 / DIMMC1 / DIMMG1 / DIMMB1
6	DIMMA1 / DIMME1 / DIMMC1 / DIMMG1 / DIMMB1 / DIMMF1
7	DIMMA1 / DIMME1 / DIMMC1 / DIMMG1 / DIMMB1 / DIMMF1 / DIMMD1
8	DIMMA1 / DIMME1 / DIMMC1 / DIMMG1 / DIMMB1 / DIMMF1 / DIMMD1 / DIMMH1

CPU Installation and Removal

Supports a single Intel Xeon Ice Lake Scalable Processor (LGA 4189)

- A. Creating the Intel Ice Lake Carrier Assembly Module (PHM)**
1. Locate small gold triangle (Pin 1) on processor and corresponding hollowed triangle on carrier.
 2. Using the triangles as a guide, carefully align and snap into place to fasten onto Point B.
- B. Assembling the Processor Heatsink Module (PHM)**
1. Turn the heatsink upside down, and hold the processor carrier assembly with the gold contacts facing up.
 2. Align the triangle (Pin 1) on the assembly with the triangle cutout "A" of the heatsink and press into place such that the clips lock in.

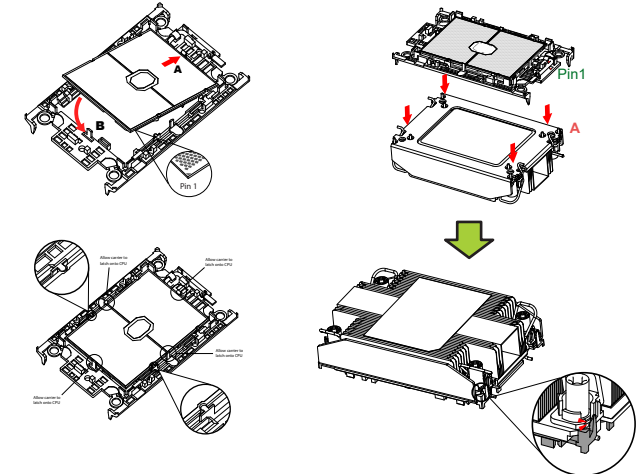

- C. Preparing the CPU Socket for Installation**
- Gently pull off the plastic protective cover by one corner to remove it from the CPU socket.

- D. Installing the Processor Heatsink Module**
1. Align the golden triangle (Pin 1) of the processor with the printed triangle on the socket. All four holes should be aligned.
 2. Ensure that the four rotating wires are in an "up" (unlocked) position.
 3. Mount the PHM onto the CPU socket on the motherboard and gently press into place. Flip the rotating wires to the sides to a locked position.
 4. With a T30 Torx-bit screwdriver, gently tighten peek nuts 1-4 in the order described on the heatsink label.

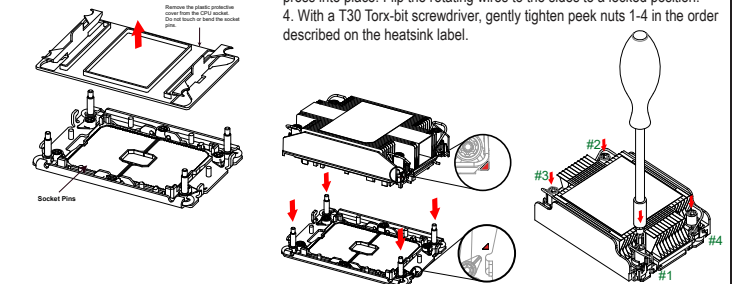

Removing the Processor Heatsink Module

1. Using a T30 Torx-bit screwdriver, loosen the four peek nuts in a backward sequence of 4, 3, 2, 1.
2. Ensure that the four rotating wires are in an "up" (unlocked) position.
3. Gently lift the module up to remove it from the socket.
4. Flip the PHM with the gold contacts facing up. Unlock the lever and gently remove the CPU.

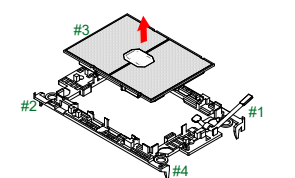

Caution

SAFETY INFORMATION
IMPORTANT: See installation instructions and safety warning before connecting system to power supply.
http://www.supermicro.com/about/policies/safety_information.cfm

WARNING:
To reduce risk of electric shock/damage to equipment, disconnect power from server by disconnecting all power cords from electrical outlets. If any CPU socket empty, install protective plastic CPU cap

WARNING:
Always be sure all power supplies for this system have the same power output. If mixed power supplies are installed, the system will not operate.

For more information go to : <http://www.supermicro.com/support>

