

DS-SFP-FC32G-SW-AO

Cisco® Compatible TAA Compliant 32GBase-SW Fibre Channel SFP+ Transceiver (MMF, 850nm, 100m, LC, DOM)

Features:

- SFF-8432 and SFF-8472 MSA Compliant
- Compliant with IEEE 802.3ae
- Duplex LC Connector
- Up to 28.05Gbps bi-directional data links
- VCSEL transmitter and PIN receiver
- Up to 100m over multi-mode fiber
- Built-in digital diagnostic functions
- 3.3V power supply and 1W power dissipation
- Support Hot Pluggable
- Metal with lower EMI
- Excellent ESD protection
- RoHS compliant and Lead Free

Applications:

- Tri-Rate 8.5/14.025/28.05 Gbps Fibre Channel
- 32G Fibre Channel
- Access, Datacentre and enterprise

Product Description

This Cisco® compatible SFP+ transceiver provides 32GBase-SW Fibre Channel throughput up to 100m over multi-mode fiber (MMF) using a wavelength of 850nm via an LC connector. It is guaranteed to be 100% compatible with the equivalent Cisco® transceiver. This easy to install, hot swappable transceiver has been programmed, uniquely serialized and data-traffic and application tested to ensure that it will initialize and perform identically. Digital optical monitoring (DOM) support is also present to allow access to real-time operating parameters. This transceiver is Trade Agreements Act (TAA) compliant. We stand behind the quality of our products and proudly offer a limited lifetime warranty.

AddOn's SFP+ transceivers are RoHS compliant and lead-free.

TAA refers to the Trade Agreements Act (19 U.S.C. & 2501-2581), which is intended to foster fair and open international trade. TAA requires that the U.S. Government may acquire only "U.S. – made or designated country end products."



Regulatory Compliance

- ESD to the Electrical PINs: compatible with MIL-STD-883E Method 3015.4
- ESD to the LC Receptacle: compatible with IEC 61000-4-3
- EMI/EMC compatible with FCC Part 15 Subpart B Rules, EN55022:2010
- Laser Eye Safety compatible with FDA 21CFR, EN60950-1& EN (IEC) 60825-1,2
- RoHS compliant with EU RoHS 2.0 directive 2015/863/EU

Absolute Maximum Ratings

Parameter	Symbol	Min.	Max.	Unit
Maximum Supply Voltage	V _{CC}	0	3.6	V
Storage Temperature	T _S	-40	85	°C
Operating Case Temperature	T _C	0	70	°C
Operating Humidity	RH	5	85	%
Receiver Power	R _{MAX}		-1	dBm
Maximum Bitrate	B _{max}	8.5	28.05	Gbps

Electrical Characteristics (TOP=25°C, V_{CC}=3.3Volts)

Parameter	Symbol	Min.	Typ.	Max.	Unit	Notes
Power Supply Voltage	V _{CC}	3.13	3.30	3.47	V	
Power Supply Current	I _{CC}			300	mA	
Power Consumption	P _{DISS}			1	W	
Transmitter						
Differential data input swing	28.05Gbps	V _{in,pp}	50		900	mV
	14.025Gbps & 8.5Gbps	V _{in,pp}	180		700	mV
Input differential impedance	Z _{in}	90	100	110	Ω	
Receiver						
Differential data output swing	V _{out, pp}	300		850	mV	
Output differential impedance	Z _{in}	90	100	110	Ω	

Optical Characteristics

Parameter		Symbol	Min.	Typ.	Max.	Unit	Notes
Transmitter							
Optical Power (average)	28.05Gbps	P_{AVE}	-8.2			dBm	1
	14.025Gbps	P_{AVE}	-7.8			dBm	1
	8.5Gbps	P_{AVE}	-6.7			dBm	1
Optical Modulation amplitude (OMA)	28.05Gbps	P_{OMA}	-3.2			dBm	2
	14.025Gbps	P_{OMA}	-4.8			dBm	2
	8.5Gbps	P_{OMA}	-5.2			dBm	2
Optical Extinction Ratio		ER	2			dB	
Optical Wavelength		$T\lambda$	840	850	860	nm	
Insertion loss		IL		2			
Receiver							
Receiver Sensitivity (average)		R_{AVE}			-13	dBm	3
Receiver Sensitivity (OMA)	28.05Gbps	R_{OMA}			-10.2	dBm	2
	14.025Gbps	R_{OMA}			-10.5	dBm	2
	8.5Gbps	R_{OMA}			-11.2	dBm	2
Receiver overload		P_{max}	-1			dBm	4
Receiver wavelength		$R\lambda$	840		860	nm	

Notes:

1. Coupled into a Multi-mode fibre
2. Per IEEE 802.3ae specification
3. Average power, back-to-back, @10.31Gbps, BER 1E-12, PRBS 231-1.
4. Exceeding the Receiver overload can physically damage the module. Please use appropriate attenuation.

Pin Descriptions

Pin	Symbol	Name/Descriptions	Ref.
1	VeeT	Transmitter Ground (Common with Receiver Ground).	1
2	TX Fault	Transmitter Fault. LVTTTL-O	2
3	TX Disable	Transmitter Disable. Laser output disabled on high or open. LVTT-I.	3
4	SDA	2-Wire Serial Interface Data Line (Same as MOD-DEF2 in INF-8074i). LVTTTL-I/O.	
5	SCL	2-Wire Serial Interface Data Line (Same as MOD-DEF2 in INF-8074i). LVTTTL-I.	
6	MOD_ABS	Module Absent, Connect to VeeT or VeeR in Module.	4
7	RS0	Rate Select 0. Not used	5
8	LOS	Loss of Signal indication. Logic 0 indicates normal operation. LVTTTL-O.	2
9	RS1	Rate Select 1. Not used	5
10	VeeR	Receiver Ground (Common with Transmitter Ground).	1
11	VeeR	Receiver Ground (Common with Transmitter Ground).	1
12	RD-	Receiver Inverted DATA out. AC Coupled. CML-O.	
13	RD+	Receiver Non-inverted DATA out. AC Coupled. CML-O.	
14	VeeR	Receiver Ground (Common with Transmitter Ground).	1
15	VccR	Receiver Power Supply.	
16	VccT	Transmitter Power Supply.	
17	VeeT	Transmitter Ground (Common with Receiver Ground).	1
18	TD+	Transmitter Non-Inverted DATA in. AC Coupled. CML-I.	
19	TD-	Transmitter Inverted DATA in. AC Coupled. CML-O.	
20	VeeT	Transmitter Ground (Common with Receiver Ground).	1

Notes:

1. The module signal ground contacts, VeeR and VeeT, should be isolated from the module case.
2. This contact is an open collector/drain output and should be pulled up to the Vcc_Host with resistor in the range 4.7KΩ to 10KΩ. Pull ups can be connected to one or several power supplies, however the host board design shall ensure that no module contract has voltage exceeding module VccT/R +0.5.V.
3. Tx_Disable is an input contact with a 4.7KΩ to 10KΩ pull-up resistor to VccT inside module.
4. Mod_ABS is connected to VeeT or VeeR in the SFP+ module. The host may pull the contract up to Vcc_Host with a resistor in the range from 4.7KΩ to 10KΩ. Mod_ABS is asserted "High" when the SFP+ module is physically absent from a host slot.
5. Internally pulled down per SFF-8431

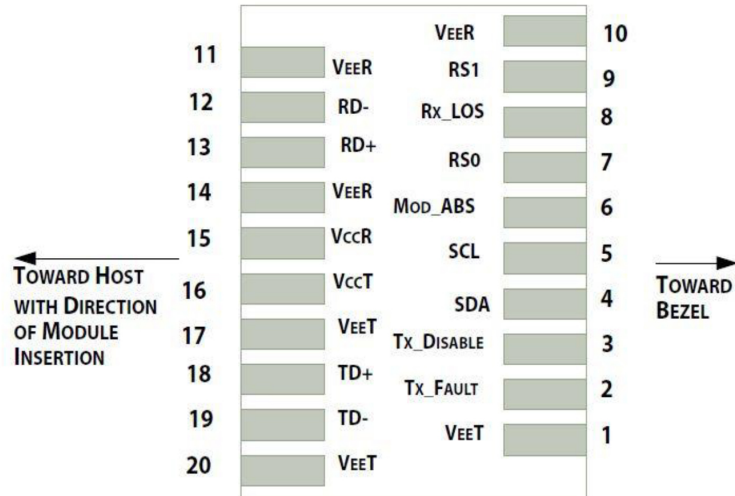

Pin-out of connector Block on Host board

Recommended Circuit Schematic

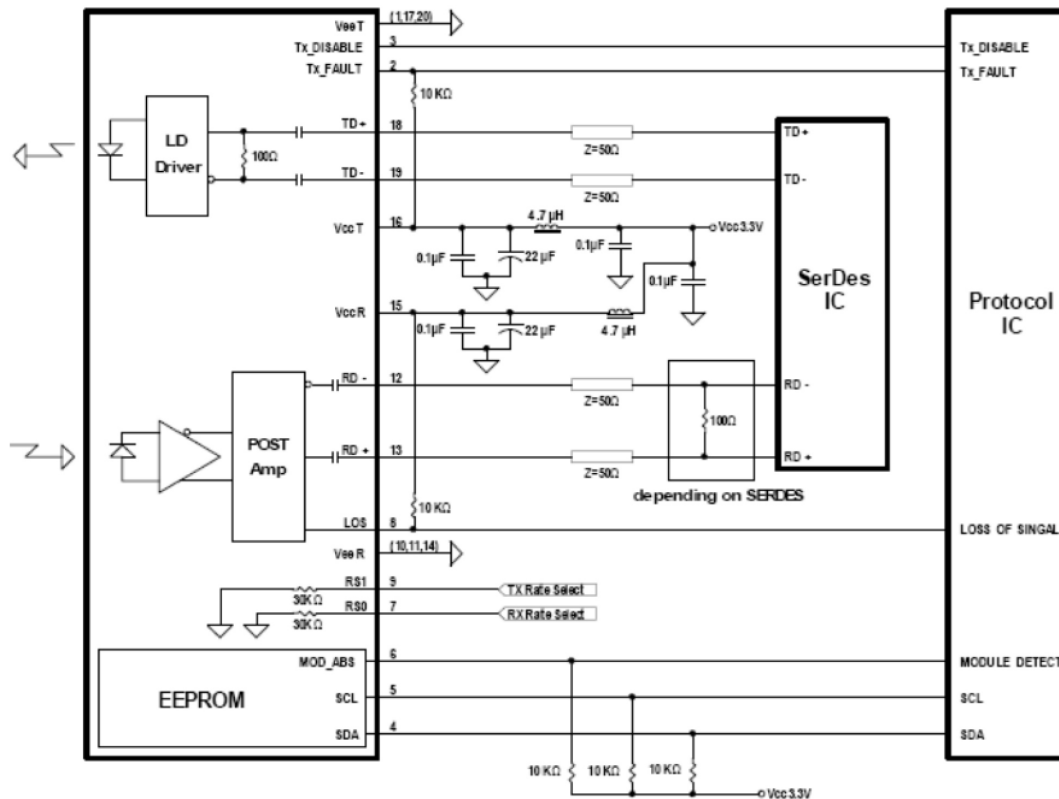

Mechanical Specifications

Small Form Factor Pluggable (SFP) transceivers are compatible with the dimensions defined by the SFP Multi-Sourcing Agreement (MSA).

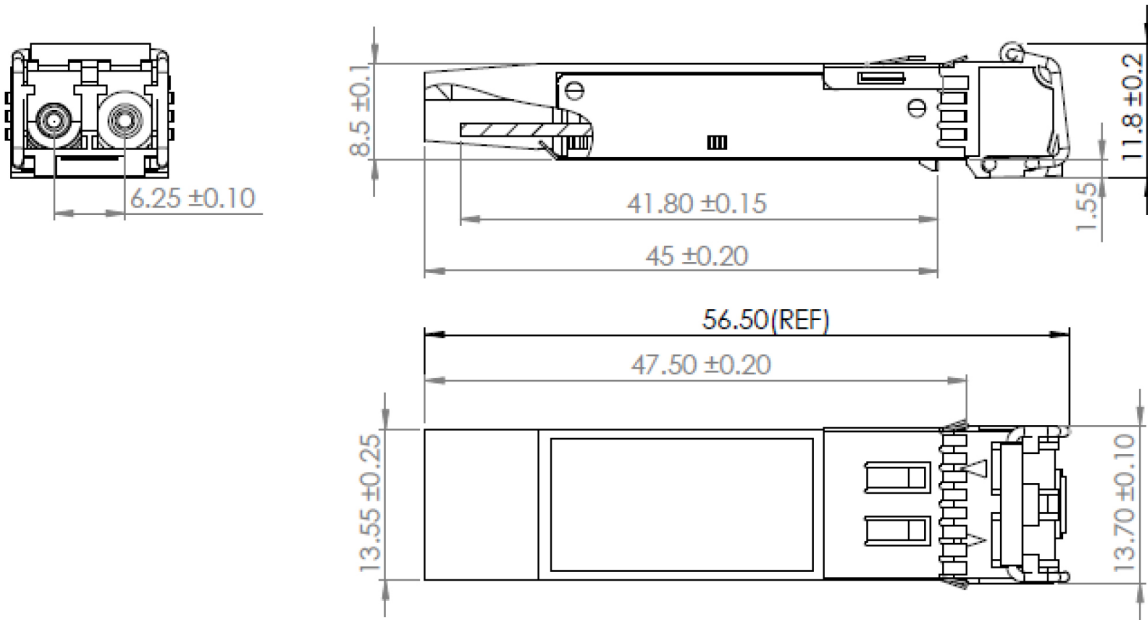

EEPROM Information

EEPROM memory map specific data field description is as below:

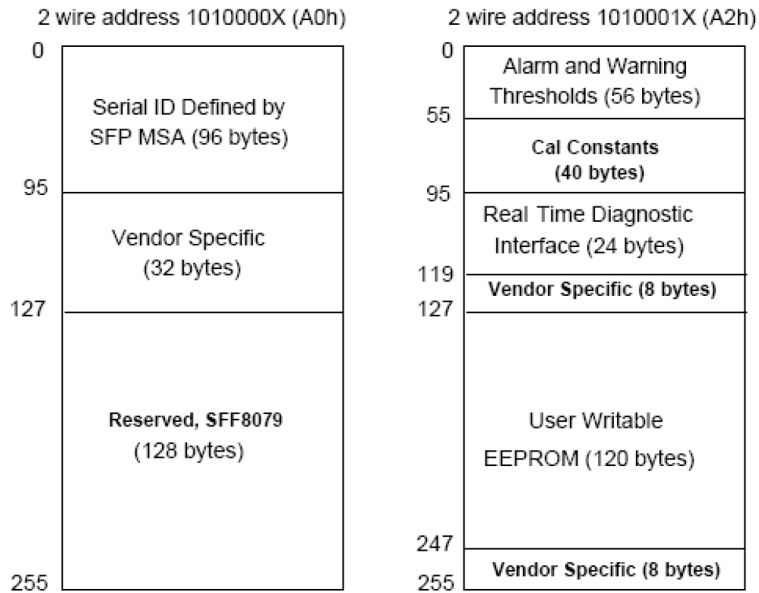

Contact Information

Founded in 1999, AddOn Networks is North America's leading provider of transceivers and high speed cabling. With a reputation for high quality products as well as an extensive custom design portfolio, AddOn has the connectivity solution regardless of the requirement.

At AddOn, 100% of the products we ship every day are tested in the specific application for which they are intended—never batch or spec tested only. We run bandwidth, distance and IOS network tests. We have documented an impressive 0.03% failure rate over the last 10 years. To continue this rate of success we invest millions annually in our own on-site testing lab.

Corporate office:
AddOn Networks
15775 Gateway Circle
Tustin, CA 92780

Tel: 877-292-1701

Fax: 949-266-9273

Email: sales@addonnetworks.com

Email: support@addonnetworks.com

Web: <http://www.addonnetworks.com>