

# HP LaserJet Pro 4006 - 4008

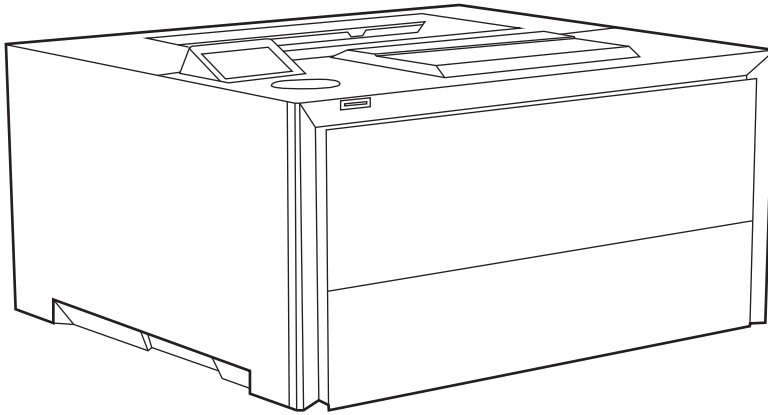

4006n, 4006dn, 4007d, 4007n, 4007dn, 4008d, 4008dn



(EN) Installation Guide  
(ES) Guide d'installation

(FR) Guía de instalación  
(PT) Guia de instalação

(ES) Lea esto primero

[hp.com/start/LJP4006](http://hp.com/start/LJP4006)  
[hp.com/start/LJP4007](http://hp.com/start/LJP4007)  
[hp.com/start/LJP4008](http://hp.com/start/LJP4008)



8X3D2-90001

1

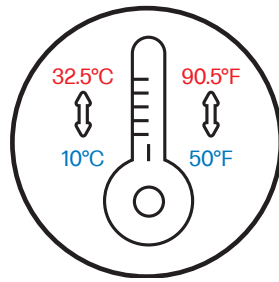
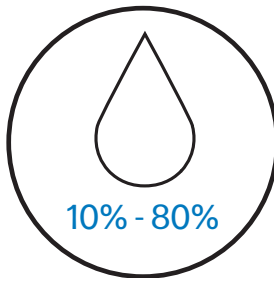
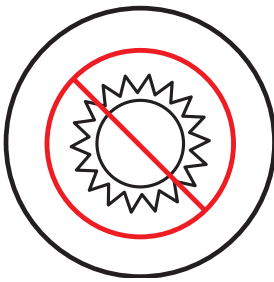
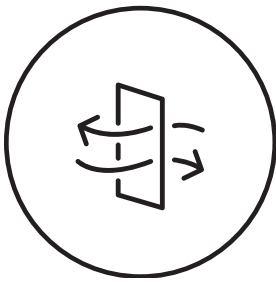

(EN) Select a stable, well-ventilated, dust-free area, not exposed to direct sunlight.

(ES) Choisissez un endroit stable, bien ventilé, sans poussière et non exposé à la lumière directe du soleil.

(FR) Sélectionnez une zone stable, bien ventilée, sans polvo y que no esté expuesta a la luz solar directa.

(PT) Selecione uma área estável, bem ventilada e sem poeira, não exposta à luz solar direta.

2

7.7 kg  
17 lb

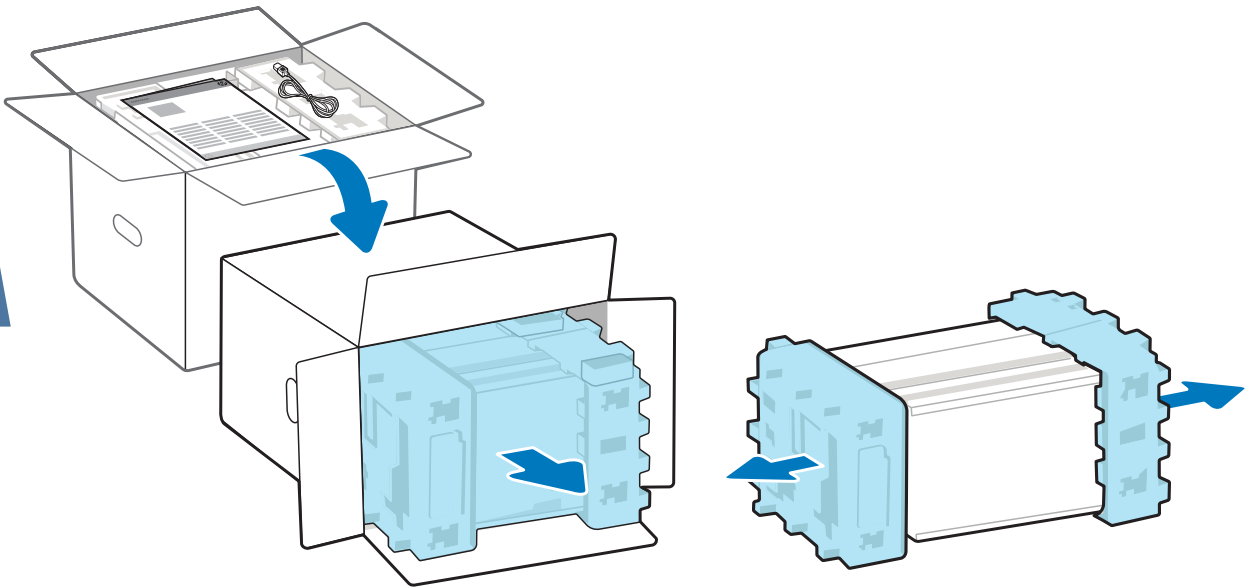

3

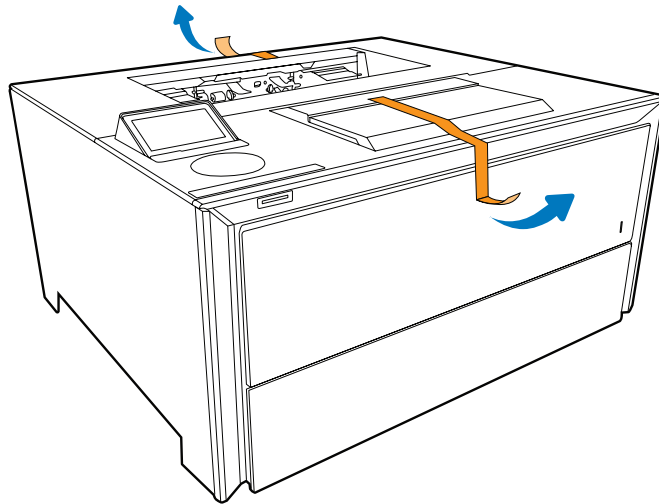

4

4.1

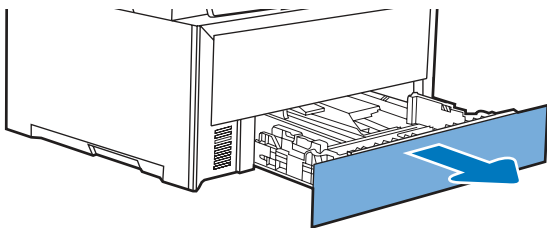

4.2

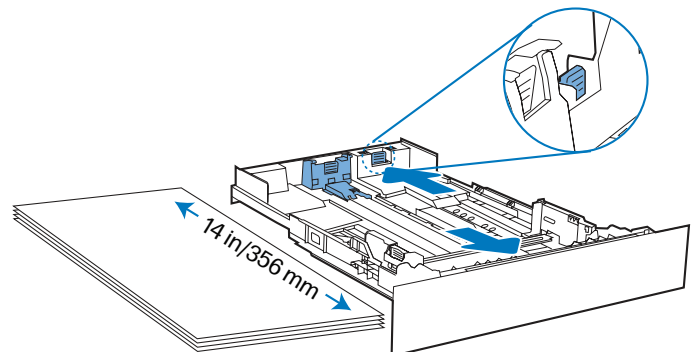
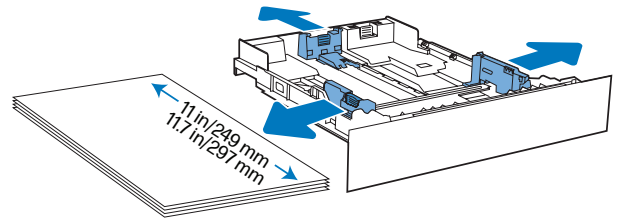

**EN** **Note**  
If loading legal paper, squeeze the latch in the rear of the tray and pull back. Tray 2 will extend from the rear of the printer an additional 110 mm (4.3 inches).

**ES** **Nota**  
Si va a cargar papel legal, apriete el pestillo situado en la parte posterior de la bandeja y tire hacia atrás. La bandeja 2 se extenderá desde la parte trasera de la impresora 110 mm adicionales.

**FR** **Note**  
Si vous chargez du papier au format Legal, appuyez sur le loquet situé à l'arrière du bac et tirez vers l'arrière. Le bac 2 dépasse l'arrière de l'imprimante de 110 mm (4,3 pouces) supplémentaires.

**PT** **Nota**  
Se estiver colocando papel ofício, aperte a trava na parte traseira da bandeja e empurre para trás. A Bandeja 2 se estenderá da parte traseira da impressora por mais 110 mm (4,3 polegadas).

## 4.3

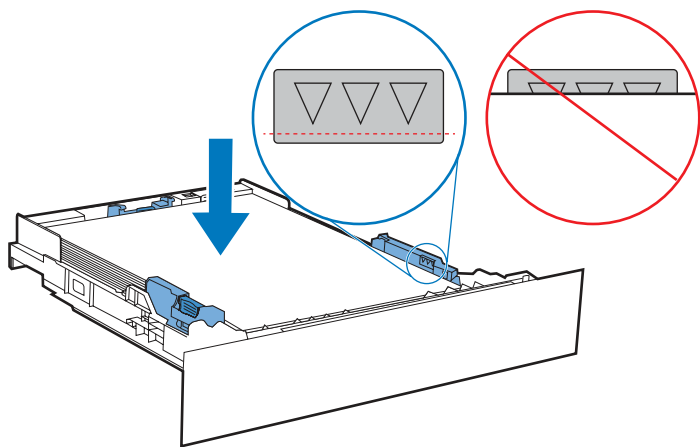

## 4.4

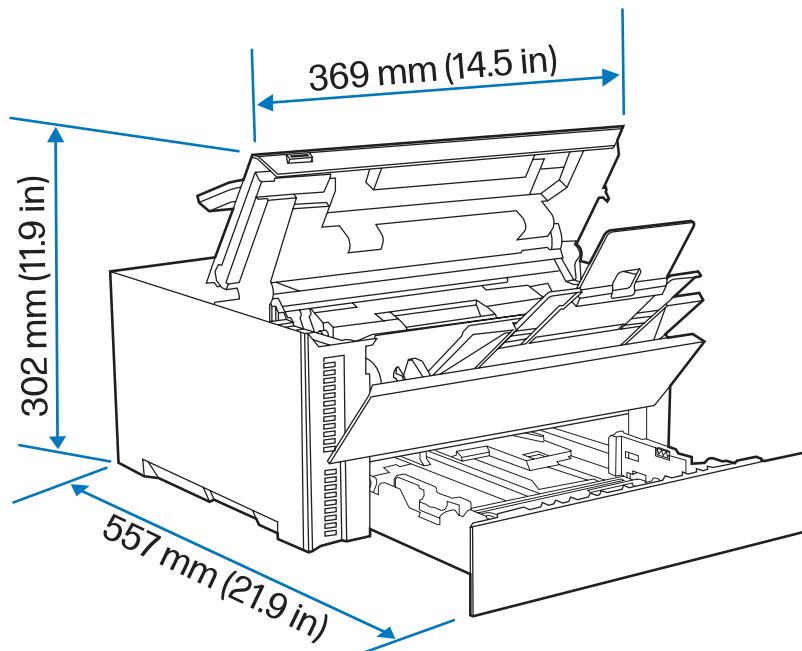
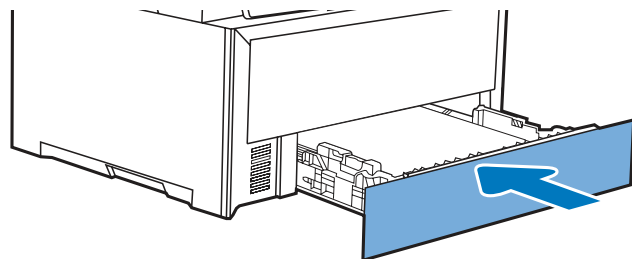

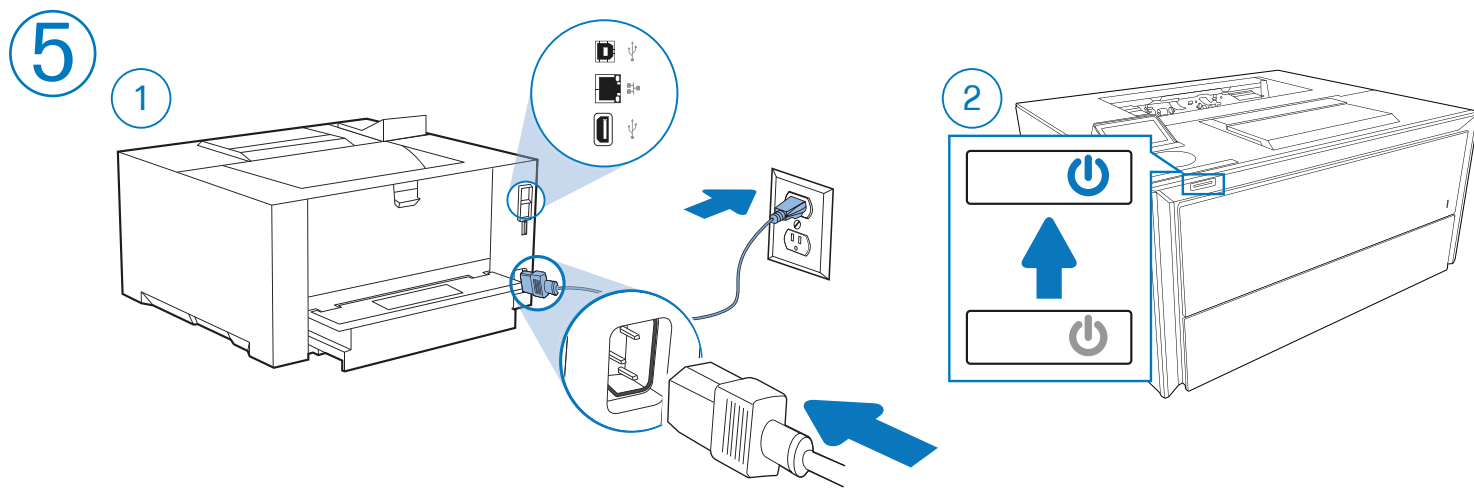

EN

**Connect and power on**

1. Connect an Ethernet or USB cable.
2. Plug in and power on the printer.

**Configure printer**

1. On the control panel, select your language and location.
2. Follow the on-screen prompts to complete printer configuration.

FR

**Connexion et mise sous tension**

1. Branchez un câble Ethernet ou USB.
2. Branchez l'imprimante et allumez-la.

**Configuration de l'imprimante**

1. Sur le panneau de commande, sélectionnez votre langue et votre région.
2. Suivez les instructions à l'écran pour compléter la configuration de l'imprimante.

ES

**Conectar y encender**

1. Conecte un cable Ethernet o USB.
2. Enchufe y encienda la impresora.

**Configurar impresora**

1. En el panel de control, seleccione su idioma y ubicación.
2. Siga los mensajes que aparecen en pantalla para completar la configuración de la impresora.

PT

**Conectar e ligar**

1. Conecte um cabo Ethernet ou USB.
2. Conecte e ligue a impressora.

**Configurar a impressora**

1. No painel de controle, selecione seu idioma e localização.
2. Siga as instruções na tela para concluir a configuração da impressora.

6



[hp.com/start/LJP4006](http://hp.com/start/LJP4006)  
[hp.com/start/LJP4007](http://hp.com/start/LJP4007)  
[hp.com/start/LJP4008](http://hp.com/start/LJP4008)

EN

#### Download software and drivers

1. Get software and drivers to enable printing from the computer.  
[hp.com/start/LJP4006](http://hp.com/start/LJP4006)  
[hp.com/start/LJP4007](http://hp.com/start/LJP4007)  
[hp.com/start/LJP4008](http://hp.com/start/LJP4008)
2. Setup is complete after driver installation.

FR

#### Téléchargement des pilotes du logiciel

1. Configurez le logiciel et les pilotes pour permettre l'impression depuis l'ordinateur.  
[hp.com/start/LJP4006](http://hp.com/start/LJP4006)  
[hp.com/start/LJP4007](http://hp.com/start/LJP4007)  
[hp.com/start/LJP4008](http://hp.com/start/LJP4008)
2. L'installation est terminée après l'installation du pilote.

ES

#### Descargar los controladores de software

1. Obtenga el software y los controladores necesarios para poder imprimir desde el equipo.  
[hp.com/start/LJP4006](http://hp.com/start/LJP4006)  
[hp.com/start/LJP4007](http://hp.com/start/LJP4007)  
[hp.com/start/LJP4008](http://hp.com/start/LJP4008)
2. La configuración finalizará después de instalar el controlador.

PT

#### Download dos drivers de software

1. Obtenha o software e os drivers para ativar a impressão a partir do computador.  
[hp.com/start/LJP4006](http://hp.com/start/LJP4006)  
[hp.com/start/LJP4007](http://hp.com/start/LJP4007)  
[hp.com/start/LJP4008](http://hp.com/start/LJP4008)
2. A Instalação é concluída após a instalação do driver.

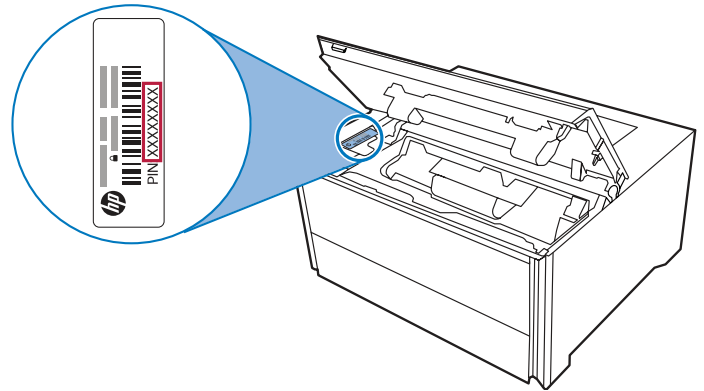
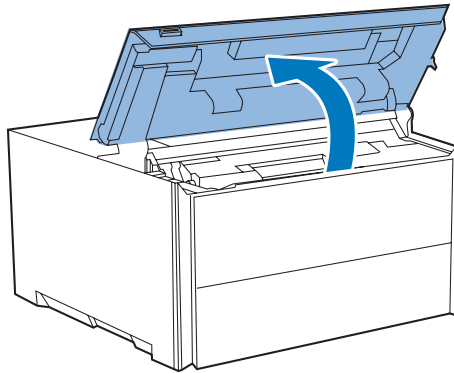

EN

#### Locate the printer PIN

If prompted for a PIN, lift the toner access door and locate the PIN label.

FR

#### Localisation du code PIN de l'imprimante

Si un code PIN vous est demandé, ouvrez le capot d'accès au toner et localisez l'étiquette du code PIN.

ES

#### Localizar el PIN de la impresora

Si se le solicita un PIN, levante la puerta de acceso al tóner y localice la etiqueta del PIN.

PT

#### Localizar o PIN da impressora

Se um PIN for solicitado, levante a porta de acesso ao toner e localize a etiqueta do PIN.

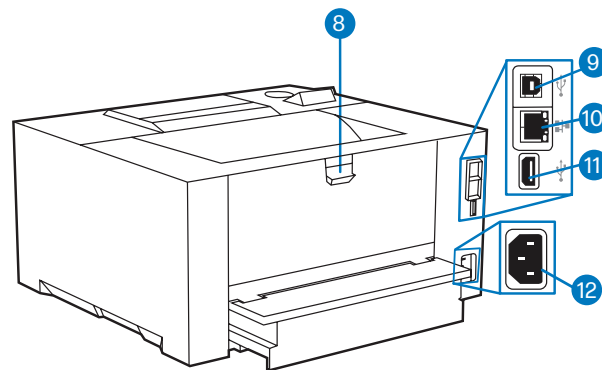
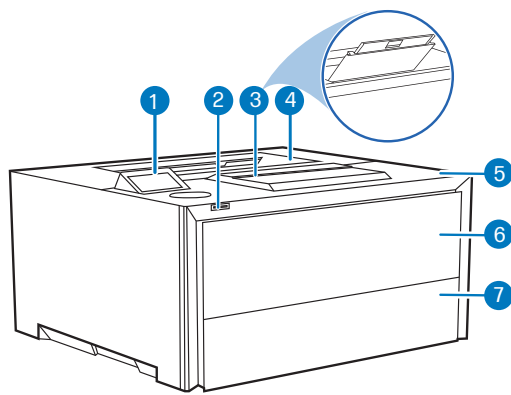

## EN Printer features

### Front view

1. Control panel
2. Power button
3. Output tray extender
4. Output tray
5. Toner access door
6. Paper tray 1
7. Paper tray 2

### Rear view

8. Rear door
9. USB port for computer connection (USB-B)
10. Ethernet port (n and dn models only)
11. USB for job storage (USB-A) (n and dn models only)
12. Power connection

## FR Caractéristiques de l'imprimante

### Vue avant

1. Panneau de commande
2. Bouton d'alimentation
3. Bras d'extension du bac de sortie
4. Bac de sortie
5. Porte d'accès au toner
6. Bac papier 1
7. Bac papier 2

### Vue arrière

8. Porte arrière
9. Port USB pour la connexion à l'ordinateur (USB-B)
10. Port Ethernet (modèles n et dn uniquement)
11. USB pour le stockage des travaux (USB-A) (modèles n et dn uniquement)
12. Branchement de l'alimentation

## ES Características de la impresora

### Vista frontal

1. Panel de control
2. Botón de encendido
3. Extensor de la bandeja de salida
4. Bandeja de salida
5. Puerta de acceso al tóner
6. Bandeja del papel 1
7. Bandeja del papel 2

### Vista posterior

8. Puerta trasera
9. Puerto USB para conexión del equipo (USB-B)
10. Puerto Ethernet (solo modelos n y dn)
11. USB para almacenamiento de trabajos (USB-A) (solo modelos n y dn)
12. Conexión de alimentación

## PT Recursos da impressora

### Vista frontal

1. Painel de controle
2. Botão Liga/Desliga
3. Extensão do compartimento de saída
4. Bandeja de saída
5. Porta de acesso ao toner
6. Bandeja de papel 1
7. Bandeja de papel 2

### Vista posterior

8. Porta traseira
9. Porta USB para conexão do computador (USB-B)
10. Porta Ethernet (somente modelos n e dn)
11. USB para armazenamento de tarefas (USB-A) (somente modelos n e dn)
12. Conexão da alimentação

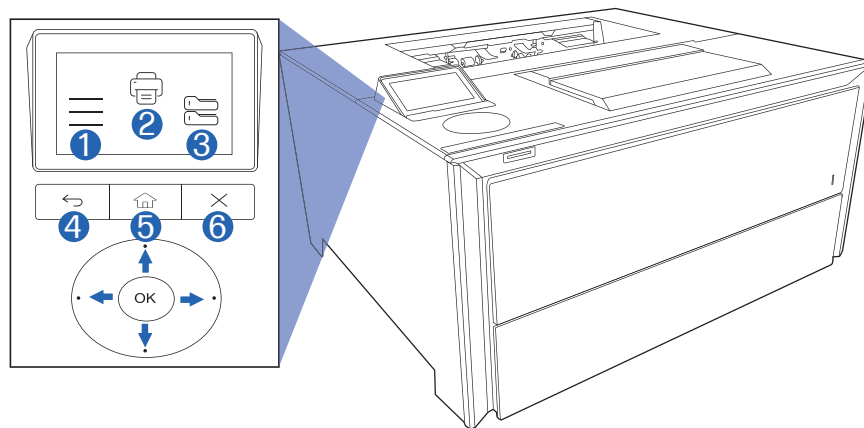

## EN Control panel

1. Menu icon
2. Print icon
3. Trays icon
4. Back button
5. Home button
6. Cancel button

## FR Panneau de commande

1. Icône du menu
2. Icône Imprimer
3. Icône Bacs
4. Bouton Précédent
5. Bouton Accueil
6. Bouton Annuler

## ES Panel de control

1. Icono Menú
2. Icono Imprimir
3. Icono Bandejas
4. Botón Atrás
5. Botón Inicio
6. Botón Cancelar

## PT Painel de controle

1. Ícone Menu
2. Ícone Imprimir
3. Ícone Bandejas
4. Botão Voltar
5. Botão Início
6. Botão Cancelar

© Copyright 2026 HP Development Company, L.P.

Reproduction, adaptation or translation without prior written permission is prohibited, except as allowed under the copyright laws.

The information contained herein is subject to change without notice.

The only warranties for HP products and services are set forth in the express warranty statements accompanying such products and services. Nothing herein should be construed as constituting an additional warranty. HP shall not be liable for technical or editorial errors or omissions contained herein.

## Trademark Credits

Microsoft, Windows, and Windows Server are trademarks of the Microsoft Group of companies.

macOS is a trademark of Apple Inc., registered in the U.S. and other countries.

AirPrint and the AirPrint logo are trademarks of Apple Inc.



La reproduction, l'adaptation ou la traduction de ce document sans l'autorisation écrite préalable de HP est interdite, sauf dans des conditions conformes aux lois relatives au copyright.

Les informations contenues dans ce document peuvent être modifiées sans préavis.

Les seules garanties pour les produits et services HP sont décrites dans les déclarations de garantie expresse qui accompagnent ces produits et services. Les informations contenues dans ce document ne constituent en aucun cas une garantie supplémentaire. HP n'est pas responsable des erreurs d'ordre technique ou éditorial ou des omissions contenues dans ce document.

## Crédits concernant les marques

Microsoft, Windows et Windows Server sont des marques commerciales du groupe de sociétés Microsoft.

macOS est une marque commerciale d'Apple Inc. aux États-Unis et dans d'autres pays/régions.

Le nom et le logo AirPrint sont des marques de commerce d'Apple Inc.

