



Epson[®] SureColor[®] F9370 User's Guide

Contents

Epson SureColor F9370 User's Guide	7
Introduction to Your Printer.....	8
Notations Used in the Documentation	8
Printer Part Locations	8
Product Parts - Top and Right Side	9
Product Parts - Inside	12
Product Parts - Back.....	13
Control Panel Parts	14
Consumables and Replacement Parts	18
Printer Usage Guidelines	19
Using Your Printer	19
Handling Ink Packs and Ink Tanks.....	20
Handling Media.....	21
Storing Your Printer	21
Media Handling.....	23
Media Handling Precautions	23
Loading Media.....	24
Viewing and Changing Media Settings.....	39
Saving Sets of Media Settings.....	41
Printable Area and Media Size Checking	42
Printing the Amount of Media Remaining	44
Aligning the Print Head.....	45
Media Feed Adjustment	46
Adjusting the Media Feed Automatically.....	47
Adjusting the Media Feed Manually.....	47
Adjusting the Media Feed During Printing	49
Adjusting Heating and Drying During Printing	49
Cutting Media	50
Using the Auto Take-up Reel	52
About the Auto Take-up Reel	52

Attaching the Take-up Roll Core to the Auto Take-up Reel	53
Take Up with the Printable Side In.....	60
Take Up with the Printable Side Out.....	66
Removing Media from the Auto Take-up Reel.....	72
Using the Control Panel Menus.....	75
Accessing the Printer's Menus	75
Media Setup Menu Settings	75
Printer Setup Menu Settings	80
Maintenance Menu Settings.....	83
Printer Status Menu Settings.....	84
Other Settings Menu Settings	84
Maintenance.....	86
When to Maintain Your Product	86
Preparing for Maintenance	88
Maintenance Supplies	88
Maintenance Precautions.....	90
Using Ink Cleaner	91
Moving the Print Head for Maintenance.....	92
Stirring High Density Black Ink	93
Replacing the Ink and Chip Unit.....	97
About Ink and Chip Unit Replacement.....	98
Ink and Chip Unit Precautions	98
Replacing the Chip Unit and Refilling Ink.....	99
Print Head Maintenance.....	112
Checking for Clogged Print Head Nozzles.....	113
Cleaning the Print Head.....	114
Cleaning Around the Print Heads	115
Cleaning the Anti-drying Caps.....	117
Cleaning the Platen and Media Edge Guides	122
Cleaning the Heat Shield.....	124
Replacing the Waste Ink Bottle	126
Replacing the Head Cleaning Set	130
Replacing the Media Edge Guides	134

Applying Carriage Rod Grease.....	141
Moving or Transporting the Product	147
Preparing to Move the Product.....	147
Setting Up the Product After Moving	148
Solving Problems	150
Product Status Messages	150
Solving Printer Problems.....	154
Printer Does Not Turn On	154
LCD Screen Shuts Off	154
After Heater Shuts Off	154
Forgot the Administrator Password	155
Red Light Shines Inside the Printer	155
Solving Printing Problems	155
Nothing Prints	155
Cannot Print Over a Network.....	156
Print Head Moves But Nothing Prints	156
Media Is Creased	157
Printing Continues After Media Roll Empties	158
Removing Jammed Media.....	158
Media Does Not Feed Correctly	161
Solving Media Skew Problems.....	161
Parallel Adjustment Tools.....	162
Adjusting the Auto Take-up Reel (Parallel Adjustment)	162
Solving Print Quality Problems.....	181
Nozzle Check Pattern Prints Incorrectly	182
Print Head Nozzles Remain Clogged	182
Overall Print Quality Is Poor	183
Printed Media Is Stained or Marred	184
Image Is Not Positioned Correctly On the Media	185
Uninstall Your Product Software.....	185
Uninstalling Printing Software - Windows	186
Where to Get Help.....	187

Technical Specifications	188
Windows System Requirements	188
Printing Specifications	189
Electrical Specifications	189
Environmental Specifications	190
Dimension Specifications	190
Interface Specifications	190
Ink Pack Specifications	191
Media Specifications	191
Safety and Approvals Specifications	192
Notices	193
Important Safety Instructions.....	193
General Product Safety Instructions	193
Ink Pack Safety Instructions	195
FCC Compliance Statement.....	195
Trademarks	196
Copyright Notice.....	196
A Note Concerning Responsible Use of Copyrighted Materials.....	197
Copyright Attribution	197

Epson SureColor F9370 User's Guide

Welcome to the Epson SureColor F9370 *User's Guide*.

For a printable PDF copy of this guide, [click here](#).

Introduction to Your Printer

Refer to these sections to learn more about your printer and this manual.

[Notations Used in the Documentation](#)

[Printer Part Locations](#)

[Consumables and Replacement Parts](#)

[Printer Usage Guidelines](#)

Notations Used in the Documentation

Follow the guidelines in these notations as you read your documentation:

- **Warnings** must be followed carefully to avoid bodily injury.
- **Cautions** must be observed to avoid damage to your equipment.
- **Notes** contain important information about your printer.
- **Tips** contain additional printing information.

Parent topic: [Introduction to Your Printer](#)

Printer Part Locations

Check the printer part illustrations to learn about the parts on your printer.

[Product Parts - Top and Right Side](#)

[Product Parts - Inside](#)

[Product Parts - Back](#)

[Control Panel Parts](#)

Parent topic: [Introduction to Your Printer](#)

Product Parts - Top and Right Side

Front/Top

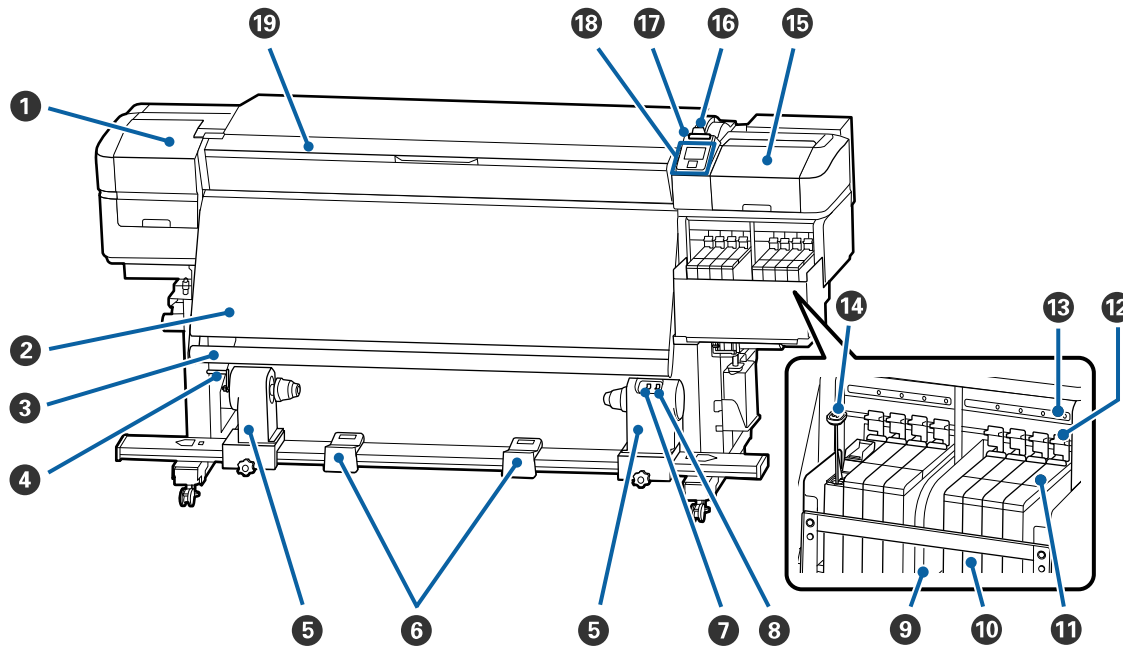

- 1 Maintenance cover (left)
- 2 After heater
- 3 Media guide bar
- 4 Roll core holder handle
- 5 Roll core holder (auto take-up reel)
- 6 Roll supports
- 7 **Auto** switch
- 8 **Manual** switch
- 9 Heat shield
- 10 Ink tank

- 11 Slider (chip holder)
- 12 Lock lever
- 13 Chip unit check light
- 14 Stirring stick
- 15 Maintenance cover (right)
- 16 Media loading lever
- 17 Alert light
- 18 Control panel
- 19 Front cover

Right Side

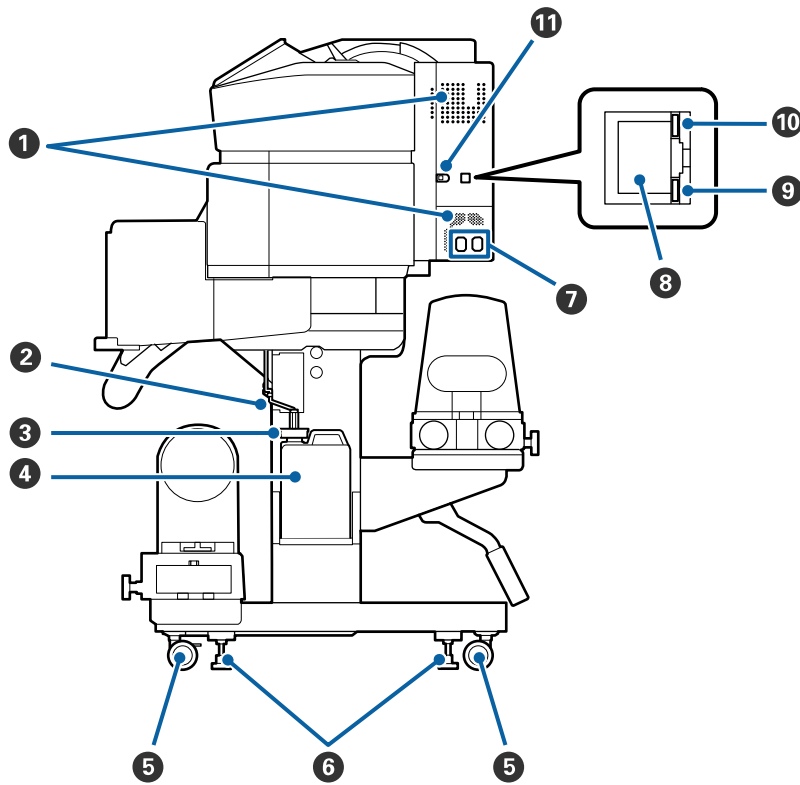

- 1 Airflow vents
- 2 Waste ink tube
- 3 Waste ink bottle stopper
- 4 Waste ink bottle
- 5 Casters
- 6 Adjusters
- 7 AC inlet #1 and #2
- 8 LAN port
- 9 Data light (orange)
- 10 Status light
Red: 100Base-TX
Green: 1000Base-T
- 11 USB port

Slider (Chip Holder) Parts

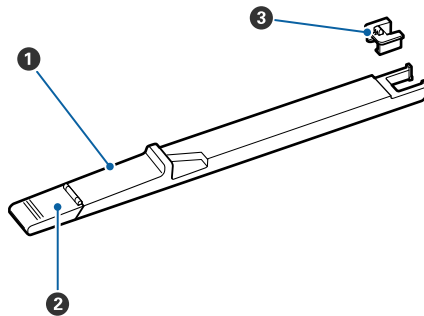

- 1 Slider
- 2 Ink inlet cover
- 3 Chip unit

Parent topic: [Printer Part Locations](#)

Product Parts - Inside

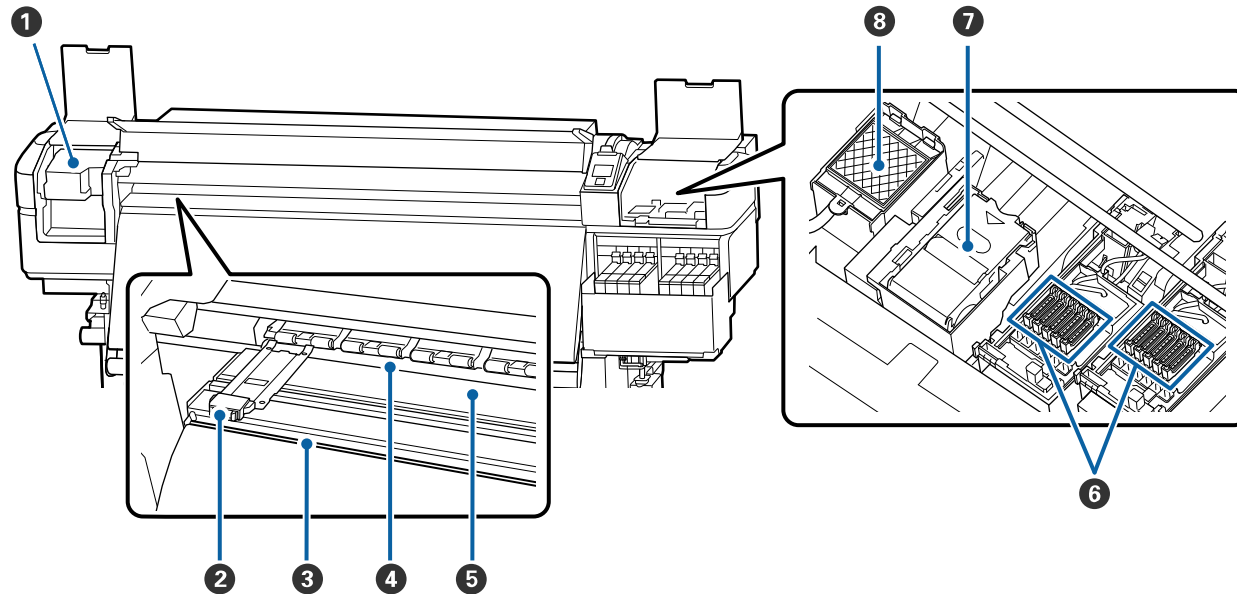

- 1 Print head
- 2 Media edge guide
- 3 Cutter groove
- 4 Pressure rollers
- 5 Platen
- 6 Anti-drying caps
- 7 Wiper unit
- 8 Flushing pad

Parent topic: [Printer Part Locations](#)

Product Parts - Back

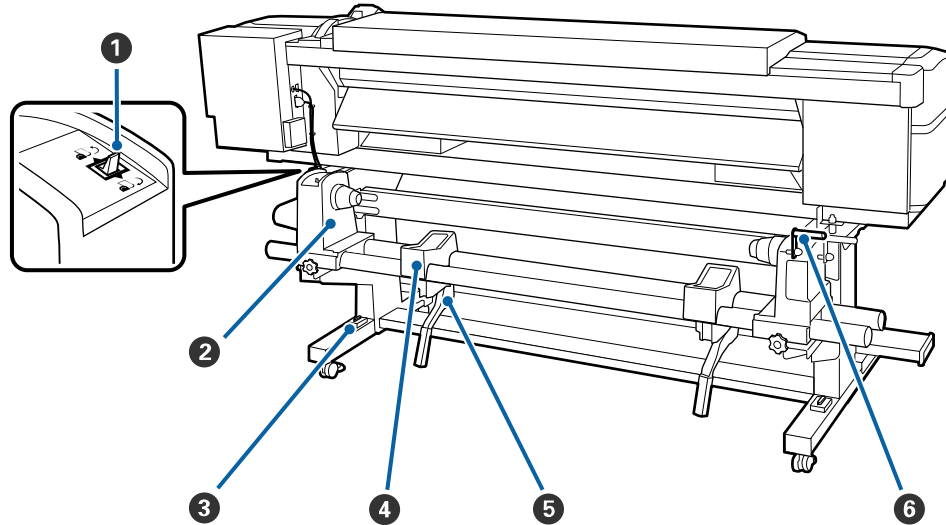



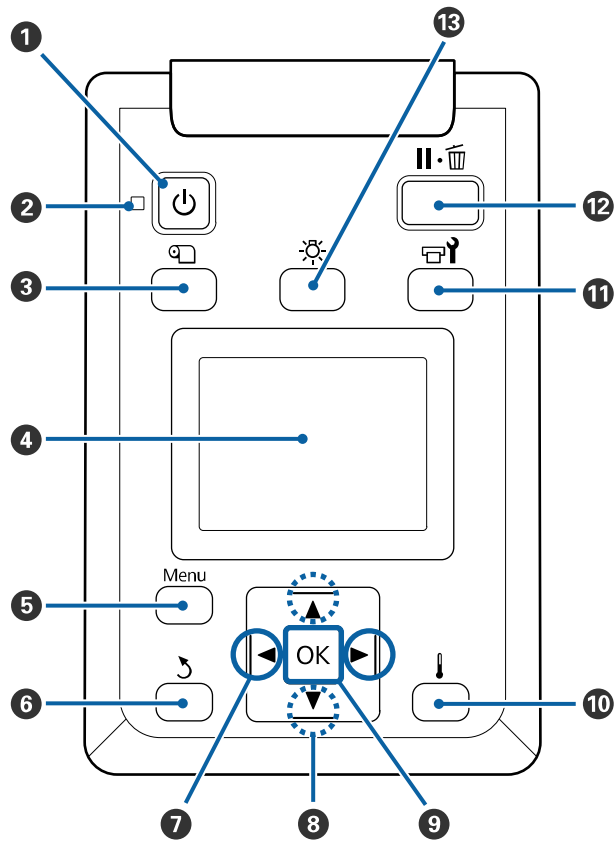

- 1 Drive switch
- 2 Roll core holder (media feeding unit)
- 3 Level gauge
- 4 Roll support
- 5 Lift lever
- 6 Roll core holder handle

Parent topic: [Printer Part Locations](#)

Control Panel Parts









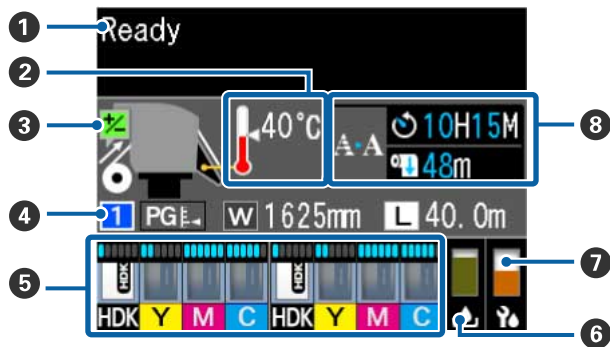





- 1  power button
- 2  power light
- 3  media setup button
- 4 LCD screen
- 5 **Menu** button
- 6  back button
- 7 Left and right arrow buttons

- 8 Up and down/media feed buttons
- 9 **OK** button
- 10 ↓ heat/dry menu button
- 11 🛠 maintenance button
- 12 || 🗑 pause/cancel button
- 13 ☀ internal light button

LCD Screen Display



1	Status messages
2	After heater temperature status  : After heater is the selected temperature  : After heater has not yet reached the selected temperature
3	Feed adjustment information, if you have entered a value during printing

4	<p>Media information</p> <p>Displays, from left to right, the selected media (0 indicates RIP settings are in use), platen gap, media width, and remaining media.</p> <p>: platen gap is 1.6</p> <p>: platen gap is 2.0</p> <p>: platen gap is 2.5</p> <p>: width of loaded media</p> <p>: remaining length of loaded media (increments of 3.9 in [0.1 m])</p> <p>: remaining length of loaded media (increments of 39.4 in [1 m])</p>
5	Chip unit status (see the next table)
6	<p>Waste ink bottle status</p> <p>The waste ink bottle status indicates the waste ink level and changes from normal (left) to warning or error status (right) if necessary.</p> <p> → </p> <p>: Waste ink bottle is almost full; prepare a new waste ink bottle</p> <p>: Waste ink bottle is full; replace the waste ink bottle</p>
7	<p>Head cleaning set status</p> <p>: The level on the icon goes down as replacement time approaches</p>
8	<p>Cleaning notification</p> <p>Displays the time or remaining media length before an automatic or periodic cleaning occurs</p>

Chip unit status

	<p>The chip unit status (1) changes from normal (left) to warning or error status (right) if necessary.</p> <p>The ink color is shown below (2).</p> <ul style="list-style-type: none"> • HDK: High Density Black • Y: Yellow • M: Magenta • C: Cyan
	<p>Remaining ink level indicators</p>
	<p>Ink is low</p>
	<p>Ink is nearing the end of its life. Check the remaining ink in the ink tank using the scale on the ink pack and, if necessary, refill the ink and replace the chip unit.</p>
	<p>Ink is out and printing is stopped. Replace the chip unit and refill the ink.</p>
	<p>A chip unit for automatic charging is mounted. When ink gets low, a low ink warning does not appear. If the icon is flashing, the chip has been removed.</p>
	<p>The lock lever is raised; automatic charging cannot occur. Lower the lock lever.</p>
	<p>The chip unit is mounted incorrectly or incompatible.</p>
	<p>Check the displayed chip unit message.</p>

Parent topic: [Printer Part Locations](#)

Related references

[Media Setup Menu Settings](#)

Related tasks

[Replacing the Waste Ink Bottle](#)

[Replacing the Head Cleaning Set](#)

[Replacing the Chip Unit and Refilling Ink](#)

Consumables and Replacement Parts

You can purchase genuine Epson ink, paper, and accessories from an Epson authorized reseller. To find the nearest reseller, visit proimaging.epson.com (U.S.) or proimaging.epson.ca (Canada), select your product series and product, and click the **Where to Buy** button. Or call 800-GO-EPSON (800-463-7766) in the U.S. or 800-807-7766 in Canada.

Caution: Using ink from an non-genuine ink pack may result in a malfunction. Epson shall not be held responsible for any damages or problems with the product that may occur when using non-genuine ink packs.

Ink pack	Part number
High-density black	T741X00
Cyan	T741200
Magenta	T741300
Yellow	T741400

Replacement part	Part number
Maintenance kit	C13S210063
Waste ink bottle	T724000
Media edge guide	C932121
Head cleaning set	C13S210051
Cleaning stick	C13S090013
Cleaning wipes	C13S090016

Option	Part number
1-year extended Epson Preferred Plus service plan	EPPF90SB1

Parent topic: [Introduction to Your Printer](#)

Printer Usage Guidelines

Follow the guidelines in these sections as you use your printer, consumables, and print media.

[Using Your Printer](#)

[Handling Ink Packs and Ink Tanks](#)

[Handling Media](#)

[Storing Your Printer](#)

Parent topic: [Introduction to Your Printer](#)

Using Your Printer

Follow these guidelines as you use your printer:

- Operate the printer only within the specified operating temperature and humidity range for your product and your media.
- Check to make sure you maintain the specified humidity range, especially in dry areas or air conditioned environments.
- Keep the printer out of direct sunlight.
- Do not install the printer next to heat sources or directly in the path of exhaust from a ventilator or air conditioner. Failure to observe this precaution could result in the print head nozzles drying out and clogging.
- Make sure the product work space is kept free of dust or lint that could damage your product or clog the print head nozzles.
- Use the product in a sufficiently ventilated area.
- When using a commercially available heater, operate it only within the specified temperature range to maintain print quality and prevent clogging the print head nozzles.
- Perform maintenance operations according to usage frequency or at the recommended intervals. Failure to perform regular maintenance could reduce print quality or damage the print head.
- Do not bend or pull on the waste ink tube. Otherwise ink may leak inside or outside the printer.

- Be sure that the waste ink bottle is installed whenever the printer is turned on.
- If an error occurs and the printer is turned off without first resolving the error, the print head may not be in the home position, which may cause the print head to dry out. In this case, turn on the power and wait until the carriage is in the home position.
- When the printer is on, do not disconnect the power cable or cut the power at the circuit breaker. The print head may not be in the home position. In this case, turn on the power and wait a while until the print head is in the home position.
- For consistent color, maintain a constant room temperature between 59 °F (15 °C) and 77 °F (25 °C).

Note: To keep the print head in the optimum operating condition, ink is used in maintenance operations such as head cleaning in addition to printing.

Parent topic: [Printer Usage Guidelines](#)

Related references

[Environmental Specifications](#)

Handling Ink Packs and Ink Tanks

Follow these guidelines as you handle the ink packs and ink tanks:

- Do not remove the ink tanks. Ink tanks are calibrated at installation and removing them can decrease their functionality.
- Do not place items on an ink tank or subject the ink tanks to strong impacts, or the tank may detach. If an ink tank comes off, contact Epson support.
- Store ink packs at room temperature, out of direct sunlight.
- To ensure print quality, use all the ink in the ink pack before the date printed on the ink pack or within 25 days of refilling the ink tank, whichever is earlier.
- Allow ink packs that have been stored at low temperatures for an extended period of time to return to room temperature for four hours before use.
- Refill the ink tank as soon as possible after opening an ink pack.
- When refilling an ink tank, use all of the ink in the ink pack at once.

Parent topic: [Printer Usage Guidelines](#)

Related references

[Ink Pack Specifications](#)

Handling Media

Follow these guidelines as you handle or store media:

- Read and follow the guidelines provided with each type of media.
- Do not fold the media or otherwise damage its printable surface.
- Do not touch the printable surface. This prevents oil from your hands from causing print quality problems.
- When handling media, hold it by both edges, preferably while wearing cotton gloves.
- Keep the media dry and avoid storage locations subject to direct sunlight, excessive heat, and high humidity.
- Retain the media packaging materials so you can use it to store unused media.
- After printing, do not touch, rub, or scratch the printed surface to avoid removing the ink.
- Dry printed media completely before folding or stacking it, or the printed surface may be damaged.
- Keep printed media out of direct sunlight.
- Display and store printed media as instructed in the media documentation.
- When you are not printing on media, remove it from the printer and place it in its original packaging to prevent deterioration.

Parent topic: [Printer Usage Guidelines](#)

Storing Your Printer

Follow these guidelines if you need to store your printer for a long period:

- If the printer is not used for an extended period of time with the power off, clean the print head nozzles. Turn the printer on at least once every two weeks to automatically clean the print head and prevent the nozzles from clogging. If you do not turn on the printer for a long time, the printer may malfunction.
- If you will not use the printer for more than two weeks, maintenance must be performed by a service engineer before and after this period. Contact Epson support.
- Even if the printer is not turned on, ink that has accumulated in the waste ink tube may leak out. Make sure the waste ink bottle is installed even when the printer is not on.
- Remove any loaded media before storing the printer to prevent the pressure rollers from causing creases in the media, which may cause jams or damage to the print head.
- Make sure that the print head is in the home position before storing the printer. If it is left away from the home position for a long time, the print quality may decline.

- Close all the covers on the printer to prevent dust and debris from getting in. If the printer will be not be used for an extended period of time, protect it with an anti-static cloth or other cover. The print head nozzles can become clogged if fine dust gets on the print head, and you may not be able to print properly.
- Store the printer on a level surface; do not store it on angle, on its end, or upside down.

Parent topic: [Printer Usage Guidelines](#)

Related references

[Where to Get Help](#)

Related tasks

[Cleaning the Print Head](#)

[Cutting Media](#)

Media Handling

See these sections to load and handle media on your product.

[Media Handling Precautions](#)

[Loading Media](#)

[Viewing and Changing Media Settings](#)

[Saving Sets of Media Settings](#)

[Printable Area and Media Size Checking](#)

[Printing the Amount of Media Remaining](#)

[Aligning the Print Head](#)

[Media Feed Adjustment](#)

[Adjusting Heating and Drying During Printing](#)

[Cutting Media](#)

[Using the Auto Take-up Reel](#)

Media Handling Precautions

Follow these guidelines as you load media in your product and remove printed media.

- Be careful when you touch the after heater and media edge guides; they may be hot and could burn you.
- Take care not to trap your fingers when opening and closing the front cover.
- Do not rub your hands along the edges of the media; the sharp edges could cut you.
- Media is very heavy, so use at least two people to carry the rolls.
- Load media just before printing on it to avoid creases from the pressure rollers; creases may cause jams or cause the media to rub against the print head.

- Do not place unwrapped media directly on the floor or press it against your clothing to avoid damaging the media surface.

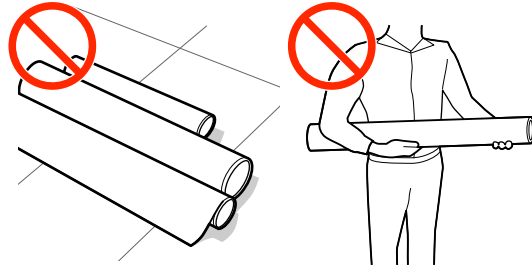

- Place unused media in its original packaging for storage.
- Do not load media if the edges are uneven on the roll; this could cause feeding problems. Rewind the media on the roll or use a different roll.

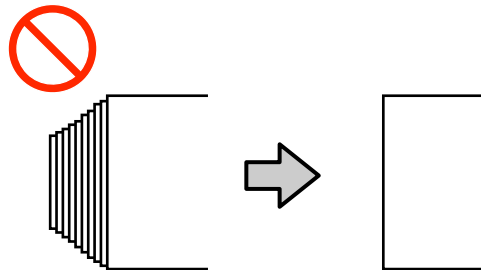

Parent topic: [Media Handling](#)

Loading Media

Before loading media in your printer, review and follow the media handling guidelines for the best results.

Caution: Wait until just before printing to load media. This avoids creases in the media that may be caused by the pressure rollers. Creased, wavy, or curled media could cause it to jam inside the printer or contact the print head.

1. Press the  power button and wait until you see this message on the LCD screen: **Load media**.

2. Open the front cover and raise the media loading lever.

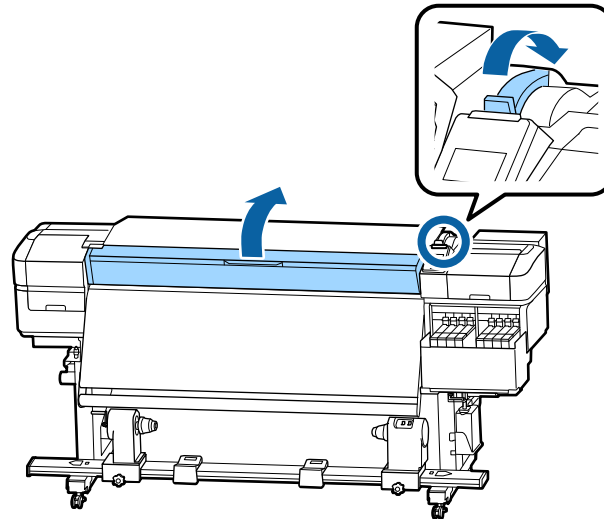

3. Grasp the tabs on the media edge guides and slide them out of the way.

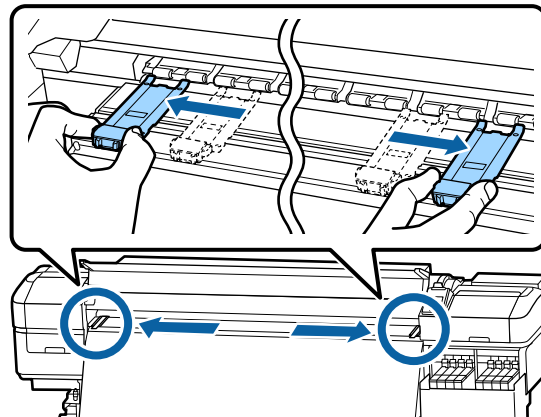

4. On the back of the product, loosen the right roll core holder locking screw and slide the roll core holder all the way out.

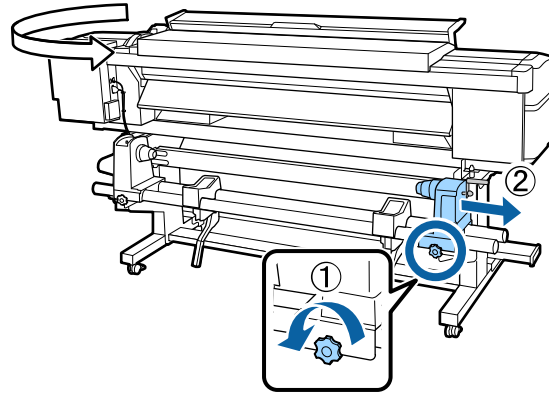

Note: If the right holder handle shaft is not visible, rotate the handle forward until it stops or the media cannot load properly.

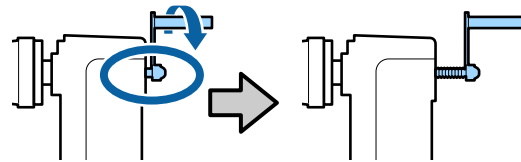

5. Move the left roll core holder to the correct position for the media roll size you are loading.

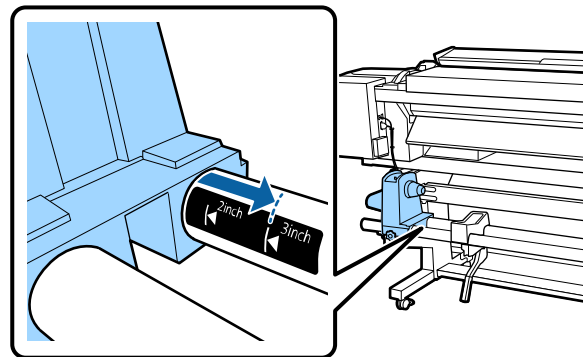

6. Hold down the left roll core holder and tighten the locking screw so the roll core holder does not move.

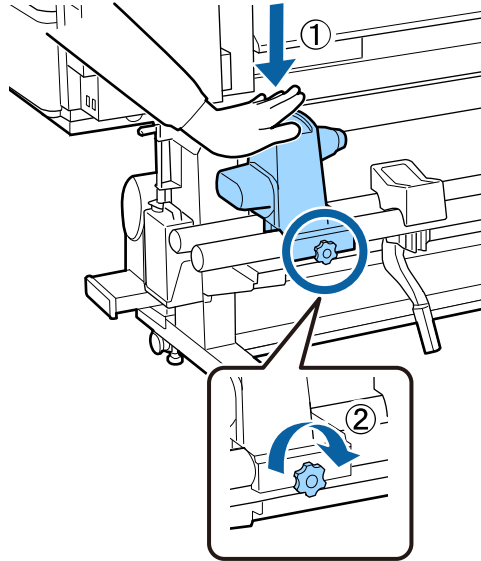

7. Place your media on the roll supports temporarily, making sure the printable side of the media on the roll faces the correct direction.

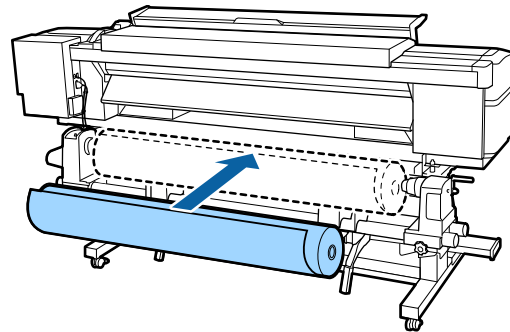

Printable side out

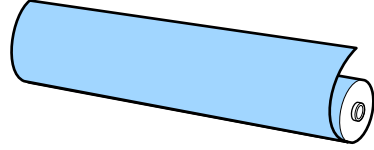

Printable side in

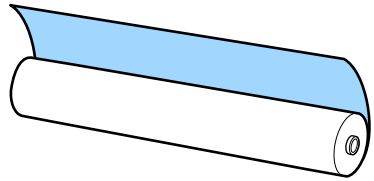

8. On the left side of the product, raise the lift lever to lift the media into position.

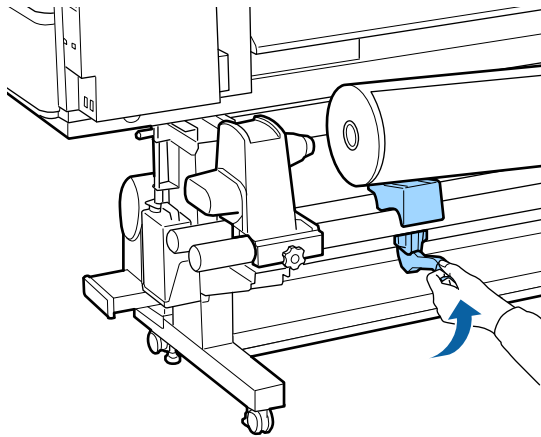

9. Firmly insert the roll core onto the left roll core holder.

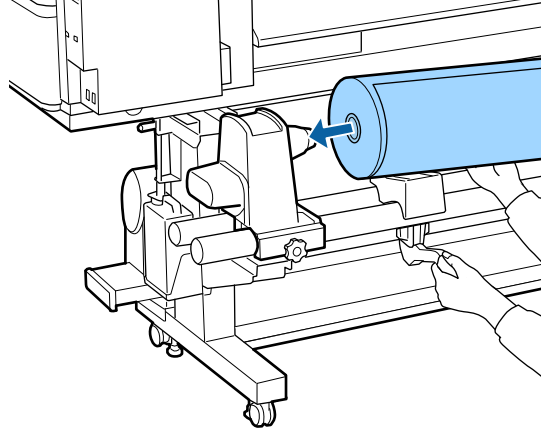

Note: If your roll is too small to lift into place with the lift lever, lift it onto the roll core holder by hand.

10. On the right side of the product, raise the lift lever to lift the media into position.

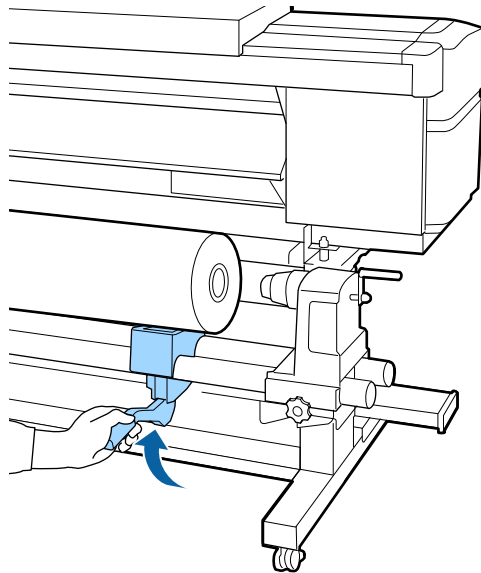

11. Firmly push the right roll core holder into the roll core.

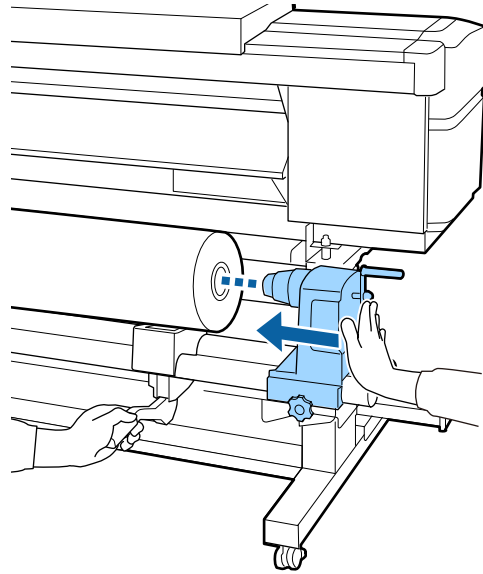

12. Push the right roll core holder twice to securely insert it into the roll core.

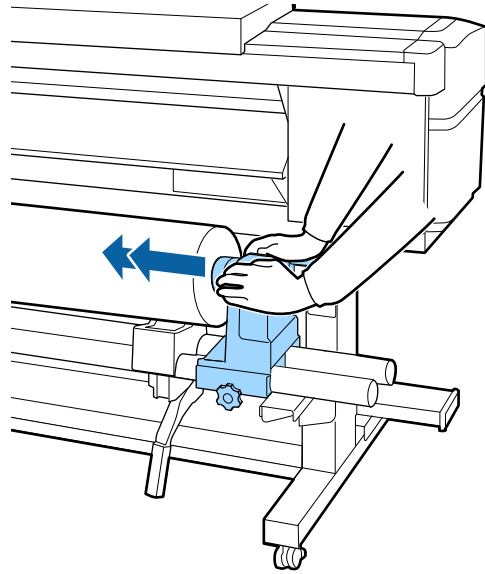

Note: Make sure the roll core holder is fully inserted into the roll core or media may not feed correctly, may slip during printing, or may cause banding in your printouts.

13. Hold down the right roll core holder and tighten the locking screw so the roll core holder does not move.

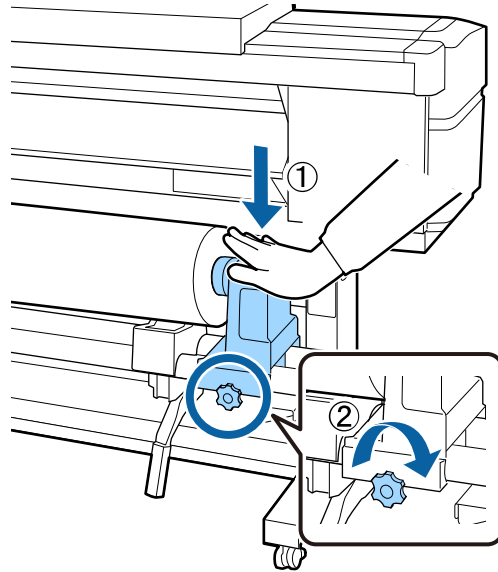

Note: Make sure the locking screw is fully secured or the roll core holder may move during printing, causing banding in your printouts.

14. Rotate the handle shown here until part A is hidden from view, then stop turning the handle.

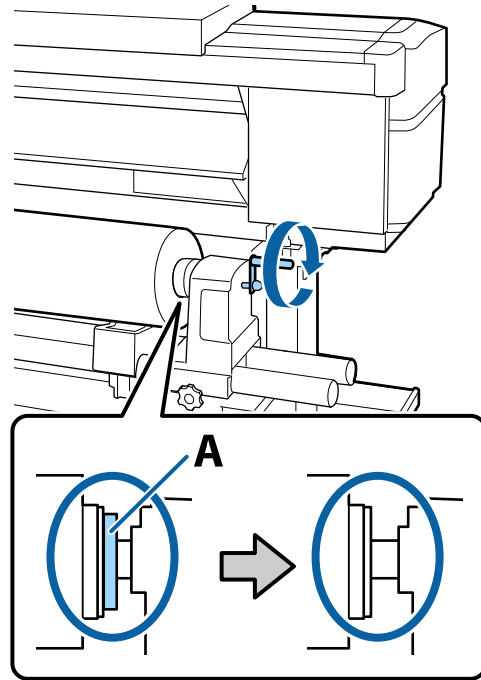

Caution: Once part A is hidden, do not turn the handle further or you may damage the roll core holder. If part A remains visible after turning the handle fully, rewind the handle, loosen the locking screw, and reload the right side of the roll on the product.

15. Make sure that the left and right sides of the media roll are aligned and realign them, if necessary.

16. Insert approximately 11.8 inches (30 cm) of media into the opening in the product, then lower the media loading lever.

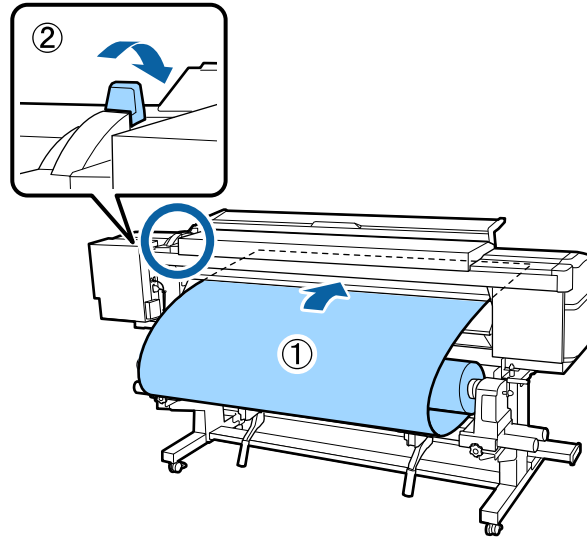

17. Confirm that the left edge of the media lays over some portion of the black rectangle on the loading guide label as shown.

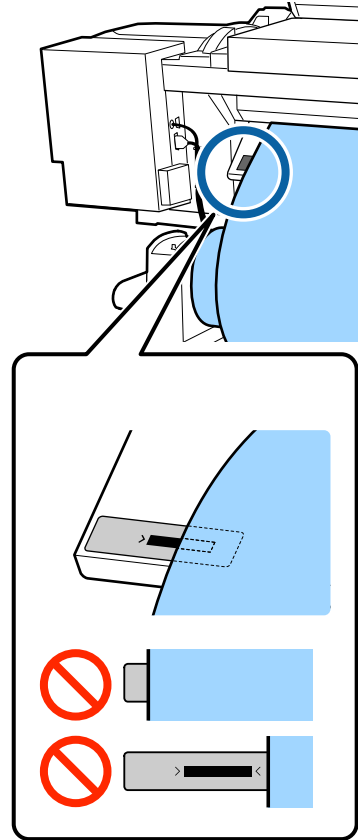

Note: If the media does not lay over the rectangle on the label, reverse these steps to remove the media and load it again. Do not reposition the roll core holders while your media is loaded.

18. On the front of the product, grasp the media and raise the media loading lever.

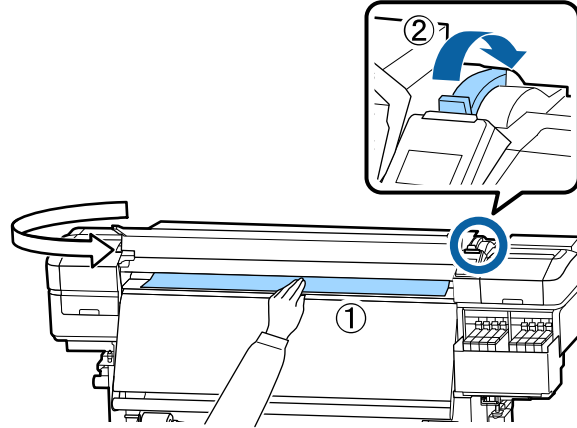

19. Hold the center of the media with one hand and pull it straight forward and down until it is aligned with the bottom edge of the label on the after heater.

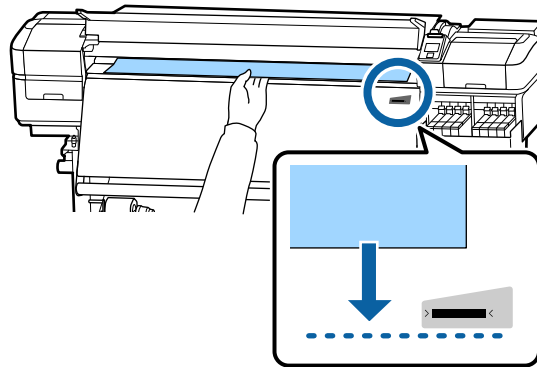

Note: Do not pull media with both hands; the media may become skewed or move around.

20. Lower the media loading lever to secure the media in place.

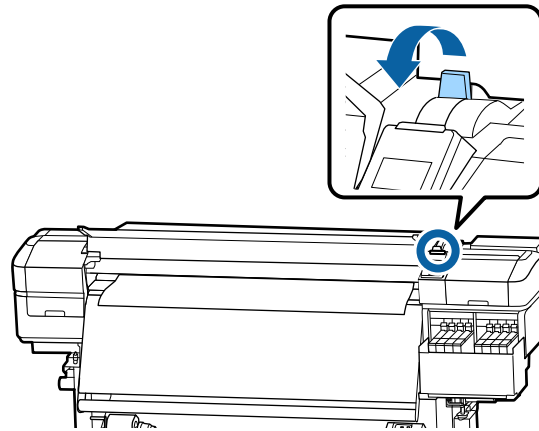

21. On the rear of the product, tap lightly on both ends of the media to check that the tension is even on both sides. If necessary, raise the media loading lever and correct the media tension, then lower the media loading lever.

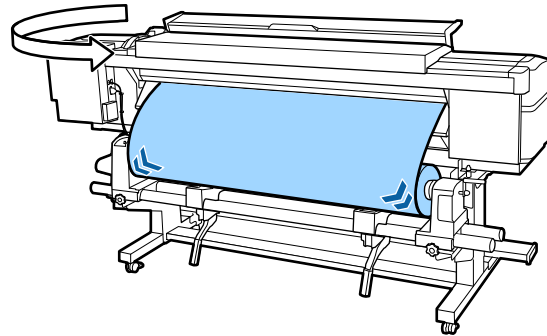

22. Grasp the tabs on the media edge guides on both sides and move them to the edges of the media. Adjust the guides so the round holes are centered over the edges of the media as shown.

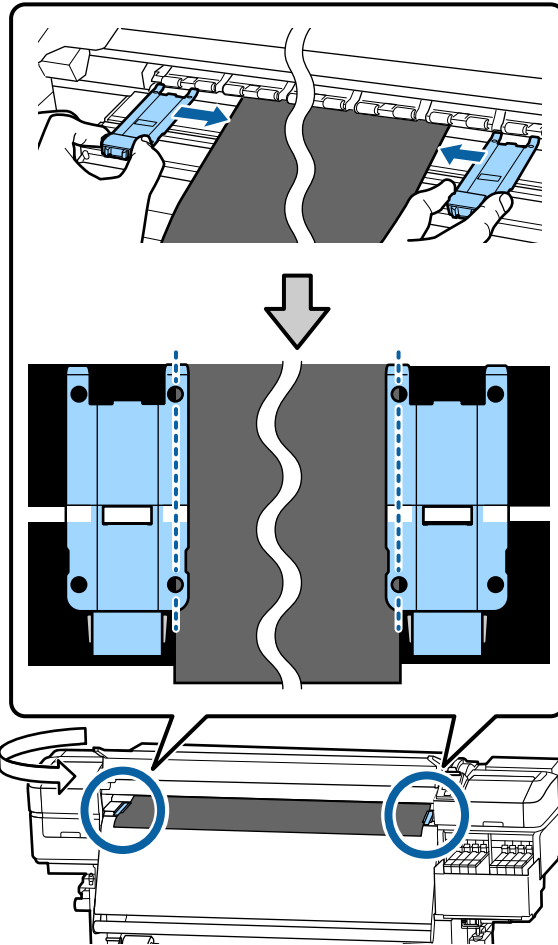

Caution: If your media is more than 0.02 inch (0.4 mm) thick, leave the media edge guides on the sides of the product or they could damage the print head.

Note: Make sure to correctly position the media edge guides as shown here or your printouts may contain banding, uneven tint, or stripes. Do not use the media edge guides if the sides of your printouts are smudged or torn.

23. Close the front cover.

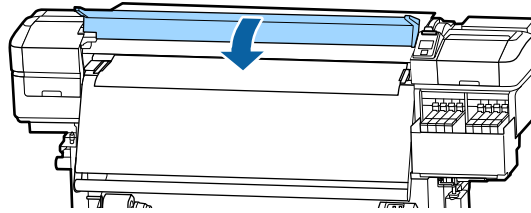

24. Select your media settings on the control panel.

Parent topic: [Media Handling](#)

Related references

[Media Handling Precautions](#)

Related tasks

[Viewing and Changing Media Settings](#)

Viewing and Changing Media Settings

After you load media in your product, you can create settings for it. The media settings include the options selected and stored for each media setting group or RIP setting you created.

1. Press the up or down arrow button to select a stored or empty media setting number for the loaded media and press the **OK** button.

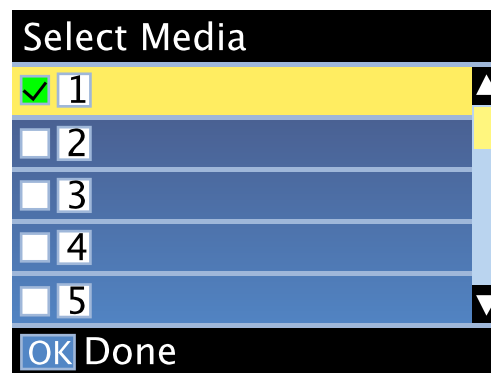

2. Press the up or down arrow button to select the roll type you loaded and press the **OK** button.

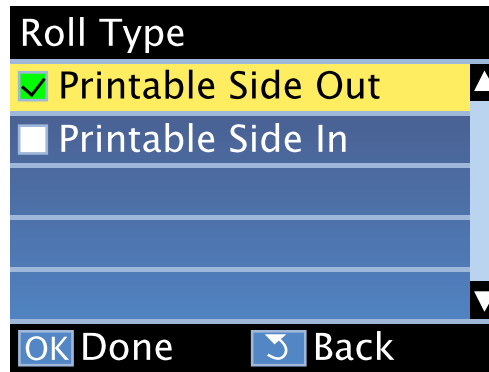

If you turned on the **Media Remaining** setting, you see a prompt to enter the length of the currently loaded media.

3. Press the up or down arrow button to select a roll length from 3 to 1968 feet (1 to 600 m) long and press the **OK** button.

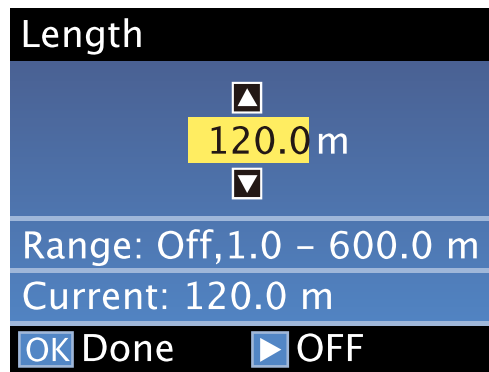

After a moment you see **Ready** on the LCD screen indicating that the printer is ready to print.

Parent topic: [Media Handling](#)

Related references

[Media Setup Menu Settings](#)

Related tasks

[Saving Sets of Media Settings](#)

Saving Sets of Media Settings

You can store sets of media settings for each type of media you use. This lets you quickly select all the necessary settings whenever you print on that media type.

Note: Make sure that you loaded the media type for which you are selecting settings.

1. Press the **Menu** button on the product control panel.
2. Press the **OK** button to select **Media Setup**.
3. Press the down arrow button to select **Easy Media Setup** and press the **OK** button.
4. Press the up or down arrow button to select a number for the set of media settings (from 1 to 30) and press the **OK** button.
5. Press the up or down arrow button to display the characters you can use to name the media set. When you see the desired character, press the right arrow button to select it and move to the next character position. Repeat this step as necessary to complete the setting name. When you finish, press the **OK** button.

Note: If you need to delete the previous character, press the left arrow button.

6. Press the up or down arrow button as necessary to select each available media setting and press the **OK** button. If necessary, press the  back button to return to the menu to select additional settings.

Parent topic: [Media Handling](#)

Related tasks

[Loading Media](#)

Printable Area and Media Size Checking

The left and right edges of media recognized by your product vary depending on the **Media Size Check** setting.

- When the **Media Size Check** setting is turned on, your product automatically detects the left and right edges of the media within 0.2 inches (5 mm), as long as the media edge guides are attached correctly.

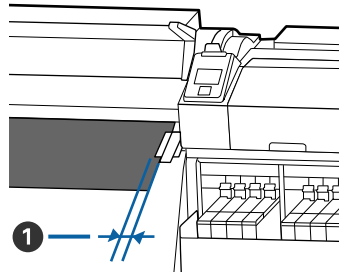

1

0.2 inches (5 mm)

- When the **Media Size Check** setting is turned off, your product uses the longest scale on the after heater label shown as the standard position for the right edge of the media. The left edge of the media is determined to be 64 inches (1626 mm) from the standard position for the right edge, no matter the width of the loaded media. The printable area ranges for the media are described in the table here.

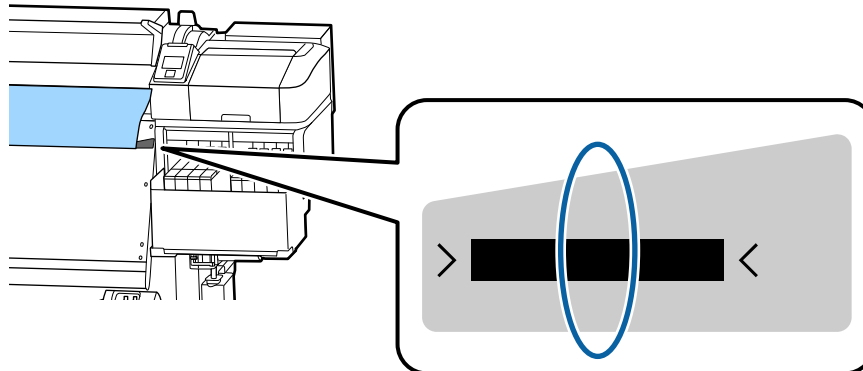

Note: If you turn off the **Media Size Check** setting, printing may occur outside the edges of your media, causing ink to stain the product. Make sure your print data width does not exceed the loaded media width. When you load media to the left of the right side reference position, adjust the **Print Start Position** setting on the product control panel to match the position where the media is loaded.

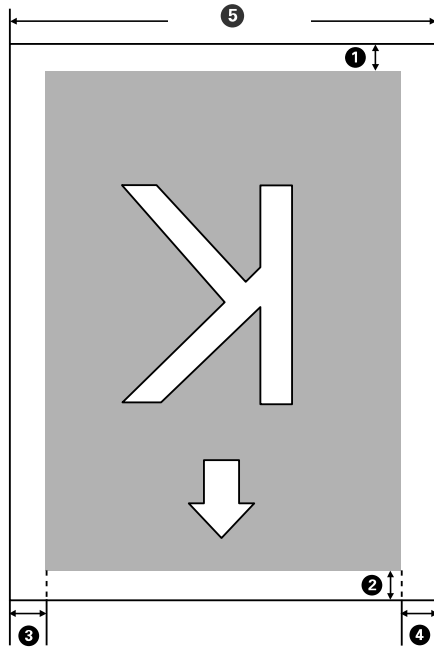

1	<p>Bottom margin¹</p> <p>You can configure this margin in the RIP software from 0.2 inch (5 mm) to 0.7 inch (17 mm); if you set it below 0.2 inch (5 mm) or above 0.7 inch (17 mm), it is changed to 0.2 inch (5 mm) and 0.7 inch (17 mm) to maintain feeding accuracy.</p>
2	<p>Top margin^{1, 2}</p> <p>You can configure this margin in the RIP software from 0.2 inch (5 mm) and above; if you set it below 0.2 inch (5 mm), it is changed to 0.2 inch (5 mm) to maintain feeding accuracy. The margin differs based on how far you pulled the media during loading.</p>

3	<p>Left margin^{3, 4}</p> <p>You select this margin as the Side Margin(Left) setting on the product control panel. The default setting is 0.2 inch (5 mm), but you can select from 0.12 inch (3 mm) to 0.98 inch (25 mm).</p>
4	<p>Right margin^{3, 4}</p> <p>You select this margin as the total of the values for the Print Start Position (default setting is 0) and Side Margin(Right) (default setting is 0.2 inch [5 mm]) settings on the product control panel. You can select from 0.12 inch (3 mm) to 32.5 inches (825 mm).</p>
5	<p>Media width</p> <p>11.8 to 64 inches (300 to 1626 mm); if Media Size Check is off, the product assumes this is 64 inches (1626 mm) regardless of the actual width</p>

¹ The configured margin and the actual print results may differ depending on the RIP software you use. Contact the RIP manufacturer for more information.

² When you set the **Margin Between Pages** setting to the **No Margin** option on the product control panel, you can adjust the margin from –0.39 inch (–10 mm) to 0.39 inch (10 mm).

³ Depending on the RIP software, you may be able to use it to set these margins. Contact the RIP manufacturer for more information.

⁴ When using the media edge guides, leave margins of at least 0.4 inch (10 mm) to avoid printing over them. If the total of the print data width and left and right margins exceeds the printable area, a portion of the print data will not print.

Parent topic: [Media Handling](#)

Related references

[Printer Setup Menu Settings](#)

Printing the Amount of Media Remaining

After you print, you can print the amount of media remaining on the leading edge of the remaining roll. This lets you enter the number the next time you load the media for the most accurate accounting of the media remaining on each roll.

Note: You must turn on the **Media Remaining** setting on the product control panel to calculate the amount of media remaining.

1. Make sure your product is ready to print.
2. Press the  media setup button.

3. Press the down button to select **Media Remaining** and press the **OK** button.
4. Press the **OK** button to select **Print Remaining Length**.
5. Press the **OK** button to print the amount of media remaining.

Parent topic: [Media Handling](#)

Related references

[Media Setup Menu Settings](#)

Aligning the Print Head

If your printouts are grainy or blurry, you need to align the print head. The thickness of your print media determines the alignment options you select. You can store separate alignment values for each type of media you use for quick selection.

Before aligning the print head, make sure you have correctly loaded the media you plan to print on.

1. Press the **Menu** button.
2. Press the **OK** button to select **Media Setup**.
3. Press the down arrow button to select **Customize Settings** and press the **OK** button.
4. Press the up or down arrow button to select the number of the media settings you selected for the currently loaded media. Then press the **OK** button.
5. Press the down arrow button to select **Media Adjust** and press the **OK** button.
6. Press the down arrow button to select **Manual** and press the **OK** button.
7. Press the down arrow button to select **Head Alignment** and press the **OK** button.

Your product prints an alignment test pattern and automatically feeds the media to viewing position.

Note: If you want to cut the media to better view the pattern, press the up arrow button to move the media past the cutter groove. Be careful not to rewind curled media past the front cover.

8. Examine the alignment test pattern to select the pattern number with the fewest gaps as shown.

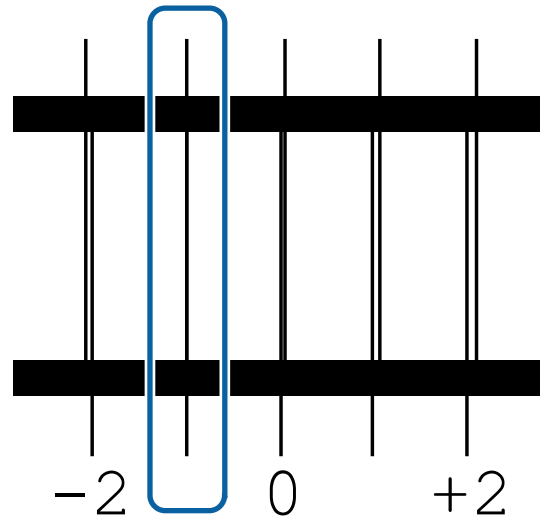

9. Press the left or right arrow button to select the number of the best pattern and press the **OK** button. Repeat this step for all the color patterns.

After you select the final color pattern number, the control panel returns to its ready status.

Parent topic: [Media Handling](#)

Related references

[Media Setup Menu Settings](#)

Media Feed Adjustment

If your printouts contain horizontal banding, uneven tint, or stripes, you need to adjust the feed of the media. You do this by printing and examining a test pattern, and then selecting the feed adjustments you need.

Adjust the feed using the same media type and print conditions you use for printing. For example, if you are using the auto take-up reel, you should use it during feed adjustment. You may need to adjust the feed again if you load media of a different width, change the feeding or take-up tension, or adjust the suction.

Before adjusting the feed, make sure you have correctly loaded the media you plan to print on and selected all the options you plan to use for printing.

Note: You can also adjust the feed during printing without printing a test pattern.

[Adjusting the Media Feed Automatically](#)

[Adjusting the Media Feed Manually](#)

[Adjusting the Media Feed During Printing](#)

Parent topic: [Media Handling](#)

Adjusting the Media Feed Automatically

You can perform an automatic feed adjustment from the product control panel. Make sure the length of the loaded media is at least 26 inches (670 mm).

1. Press the **Menu** button.
2. Press the **OK** button to select **Media Setup**.
3. Press the down arrow button to select **Customize Settings** and press the **OK** button.
4. Press the down arrow button to select **Media Adjust** and press the **OK** button.
5. Press the **OK** button to select **Auto Feed Adjustment**.

An adjustment pattern is printed. View the results and determine if a manual adjustment is necessary.

Parent topic: [Media Feed Adjustment](#)

Related references

[Media Setup Menu Settings](#)

Adjusting the Media Feed Manually

You can perform a manual feed adjustment from the product control panel if you can still see banding after performing an automatic feed adjustment.

1. Press the **Menu** button.
2. Press the **OK** button to select **Media Setup**.
3. Press the down arrow button to select **Customize Settings** and press the **OK** button.
4. Press the down arrow button to select **Media Adjust** and press the **OK** button.
5. Press the down arrow button to select **Manual** and press the **OK** button.
6. Press the **OK** button to select **Feed Adjustment**.

7. Press the up or down arrow button to select an adjustment pattern and press the **OK** button.
 - **500mm Pattern:** We recommend starting with this pattern. Make sure the length of the loaded media is at least 38 inches (970 mm).
 - **250mm Pattern:** Make sure the length of the loaded media is at least 28 inches (720 mm).
 - **100mm Pattern:** Make sure the length of the loaded media is at least 22 inches (570 mm).
 - **Standard:** Make sure the length of the loaded media is at least 13 inches (330 mm).

Your product prints an adjustment pattern and automatically feeds the media to viewing position.

8. Do the following to adjust the media feed:
 - If you selected **500mm Pattern** (recommended), **250mm Pattern**, or **100mm Pattern**, measure the distance between the **+** symbols in each test pattern as shown.

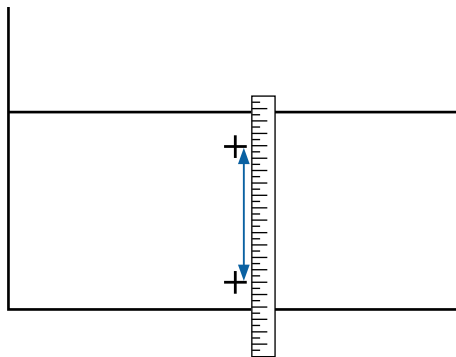

On the product control panel, enter the value for the distance between the **+** symbols and press the **OK** button.

- If you selected **Standard**, your product prints two groups of adjustment patterns (A and B).

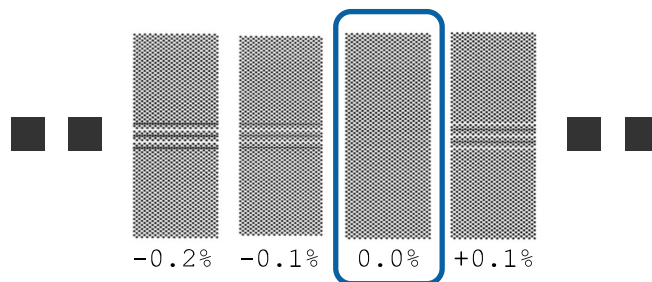

On the product control panel, enter the values with the least amount of overlapping or gaps for each group and press the **OK** button.

Parent topic: [Media Feed Adjustment](#)

Related references

[Media Setup Menu Settings](#)

Adjusting the Media Feed During Printing

You can adjust the feed and correct banding during printing without printing a test pattern.



1. During printing, press the  media setup button.
The product control panel displays an adjustment value.
2. Press the up or down arrow button to adjust the feed depending on these banding results in your printout:
 - If black bands or dark stripes appear, press the up arrow button to increase the feed amount.
 - If white bands or pale stripes appear, press the down arrow button to decrease the feed amount.
3. Check the results in your printout and do one of the following:
 - If further adjustment is necessary, repeat the last step.
 - If the print quality is good, press the **OK** button.

Parent topic: [Media Feed Adjustment](#)

Adjusting Heating and Drying During Printing

Follow the steps here to adjust the heating and drying settings during printing.

Note: If the room temperature is too low and you send a print job with high ink density or a small number of print passes, the print job may pause while the after heater warms up.

1. During printing, press the  heat/dry menu button.
2. Press the **OK** button to select **Heater Temperature**.
3. Press the up or down arrow button to change the after heater temperature.
4. Press the **OK** button.
5. Press the  back button until **Ready** appears on the LCD screen.

Parent topic: [Media Handling](#)

Related references

[Media Setup Menu Settings](#)

Cutting Media

When you finish printing, use a commercially available cutter to cut the media.

Warning: Be careful not to cut yourself when using cutters or other sharp blades. Also be careful touching areas near the after heater since the after heater may be hot and you could be burned.

1. Press  media setup button.
2. Press the **OK** button to select **Feed to Cut Position**.
3. Make sure the trailing edge of the printout has fed beyond the cutter groove on the product, then open the front cover.

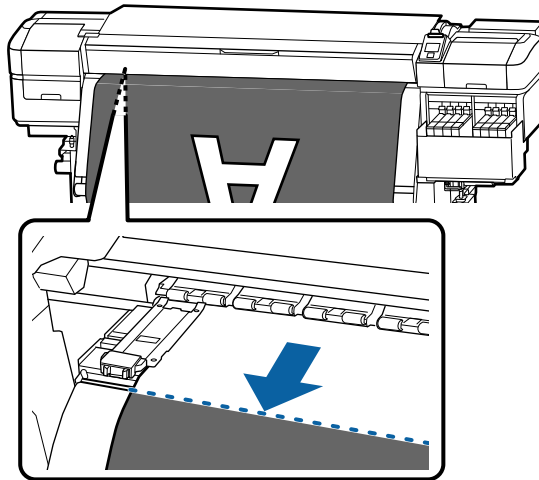

Note: If you printed the amount of media remaining onto your media, press the up arrow button to rewind the media as necessary to keep this information with the unprinted roll.

4. Use your cutting tool to cut the media along the cutter groove.

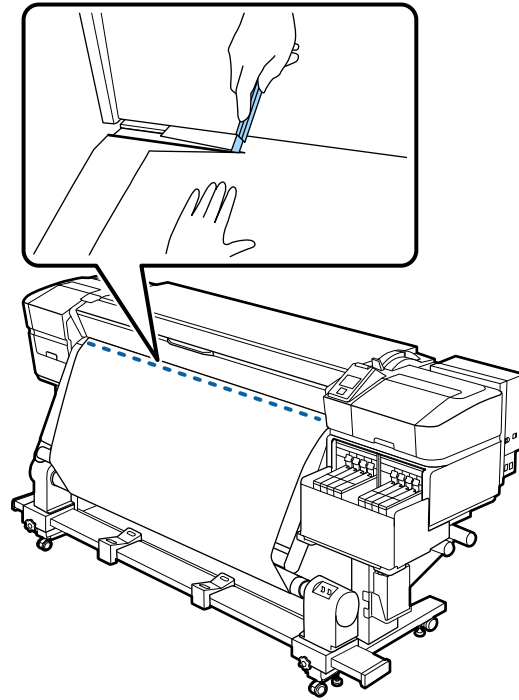

5. If you are using the auto take-up reel, move the **Auto** switch to the **off** position. Use the **Manual** switch to take up the cut media, depending on the printable side of the media:
 - Move the switch to the  position for printable-side-out media.

- Move the switch to the  position for printable-side-in media.

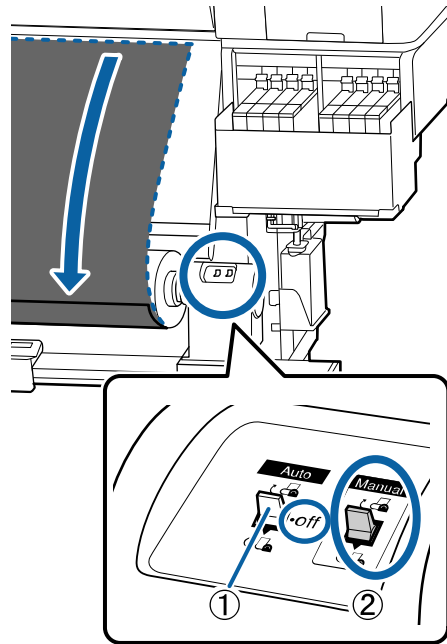

Parent topic: [Media Handling](#)

Using the Auto Take-up Reel

See these sections to use the auto take-up reel with your product.

[About the Auto Take-up Reel](#)

[Attaching the Take-up Roll Core to the Auto Take-up Reel](#)

[Take Up with the Printable Side In](#)

[Take Up with the Printable Side Out](#)

[Removing Media from the Auto Take-up Reel](#)

Parent topic: [Media Handling](#)

About the Auto Take-up Reel

The auto take-up reel automatically rolls up printed media as you print.

You can use the auto take-up reel for media with the printable side in (on the left) or printable side out (on the right).

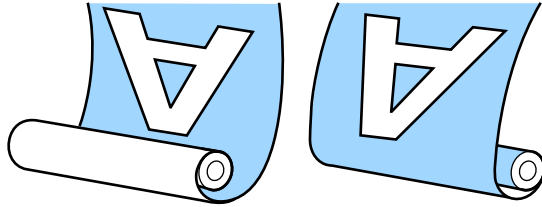

It is best to do the following when using the auto take-up reel:

- Use media that is 36 inches (91.44 cm) or wider.
- Load media with the printable side in.
- Use a take-up roll core that is the same width as your media so the core does not bend or take up media incorrectly.

Parent topic: [Using the Auto Take-up Reel](#)

Attaching the Take-up Roll Core to the Auto Take-up Reel

Be sure to attach a take-up roll core that is the same width as your media.

1. Press and hold the down arrow button until the edge of the loaded media reaches the roll core holder.

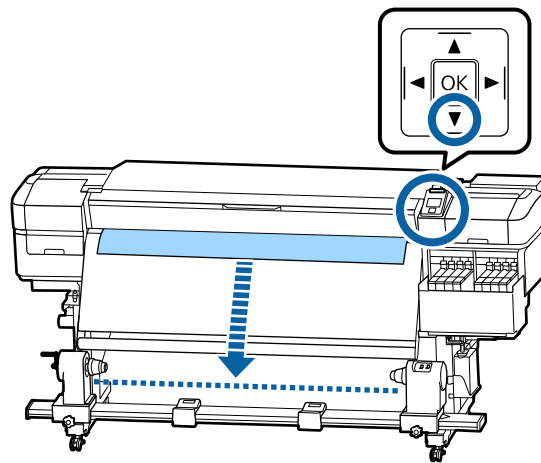

Note: Always use the down arrow button to feed loaded media or the media may twist during take-up.

2. Loosen the roll core holder locking screws and adjust the roll core holders so they are wider than your media. Then center the roll supports between the roll core holders.

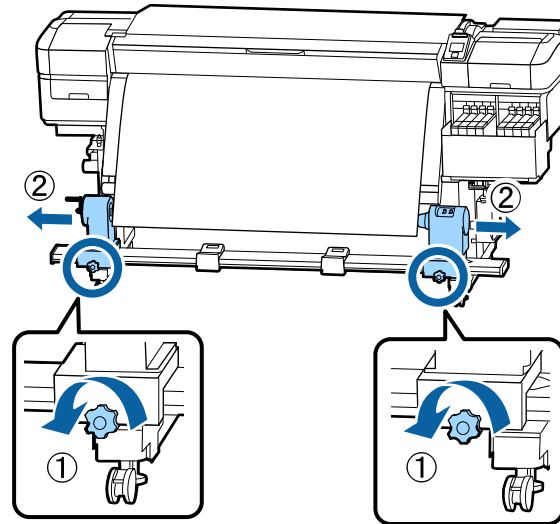

Note: If the left roll core holder handle shaft is not visible, rotate the handle as shown here until it stops or the roll core cannot take up media properly.

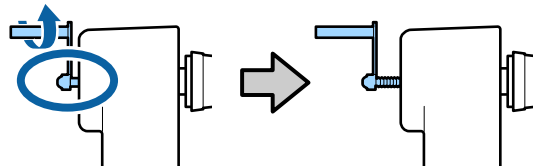

3. Align the right roll core holder with the right edge of the media.

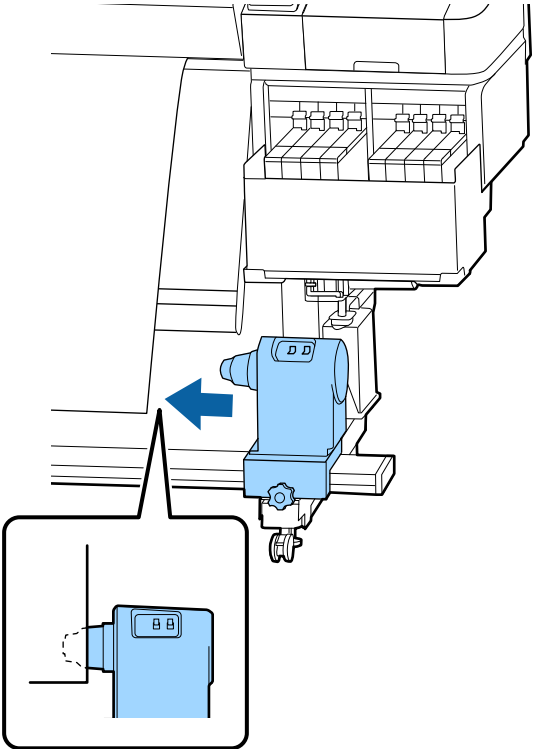

4. Hold down the right roll core holder and tighten the locking screw so the roll core holder does not move.

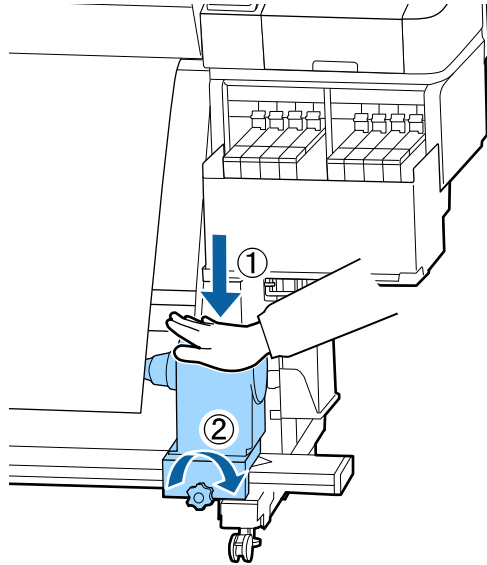

5. Insert the roll core onto the right roll core holder.

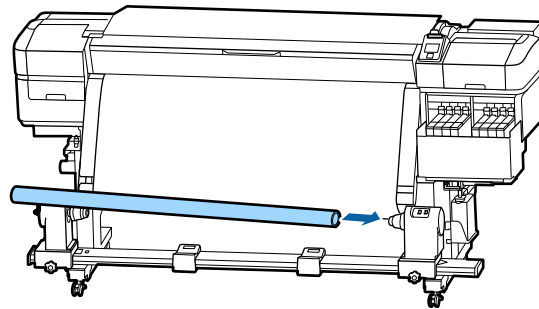

6. Insert the left side of the roll core onto the left roll core holder.

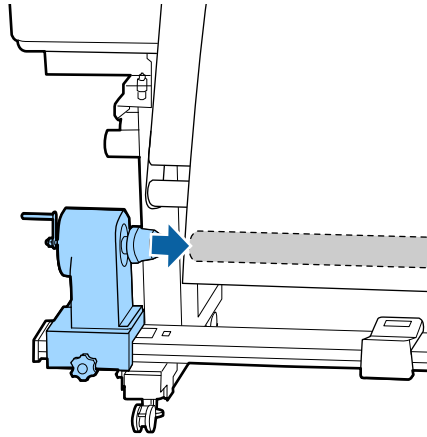

7. Push the left roll core holder twice to securely insert it into the roll core.

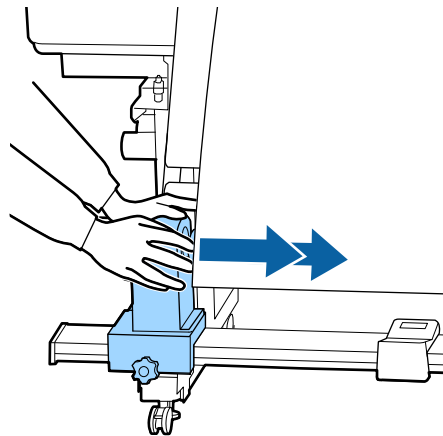

8. Confirm that the roll core and the edges of the media are aligned. If they are misaligned, loosen the right roll core holder locking screw and repeat these steps to attach the roll core again.

9. Hold down the left roll core holder and tighten the locking screw so the roll core holder does not move.

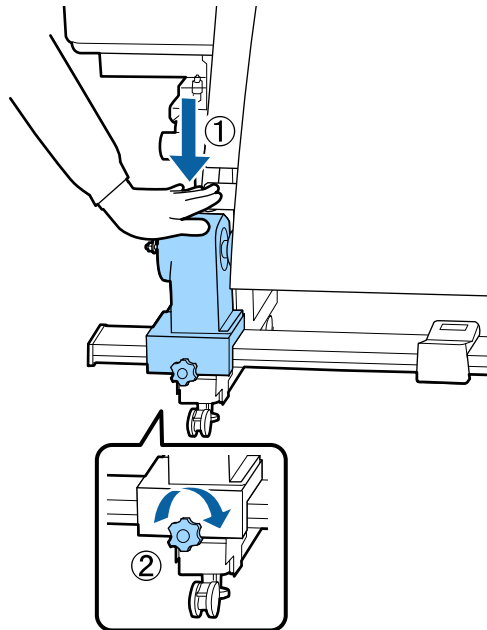

10. Rotate the handle shown here until part A is hidden from view, then stop turning the handle.

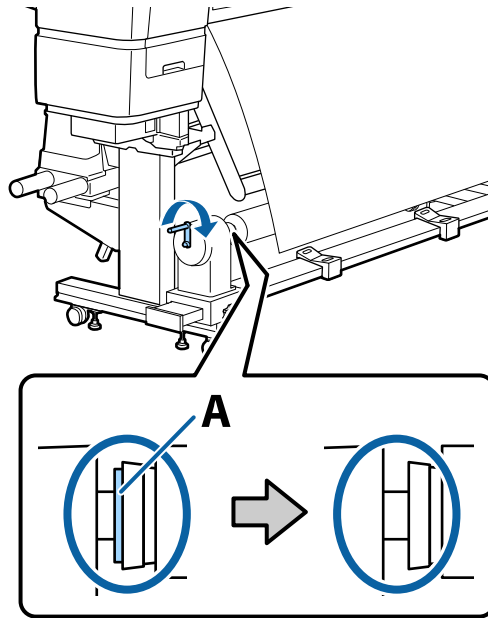

Caution: Once part A is hidden, do not turn the handle further or you may damage the roll core holder. If part A remains visible after turning the handle fully, rewind the handle, loosen the locking screw, and reload the roll core on the auto take-up reel.

11. Cut off about 9.8 inches (25 cm) from the corners of the end of the media on each side as shown to prevent folding or catching before take up.

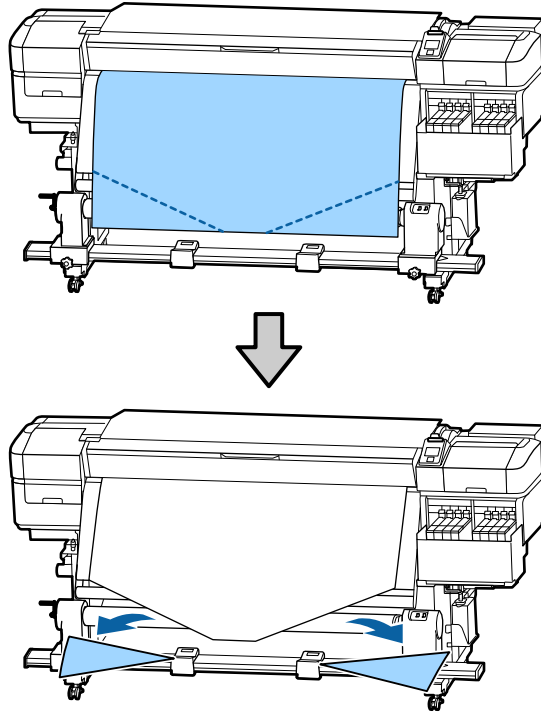

Parent topic: [Using the Auto Take-up Reel](#)

Take Up with the Printable Side In

After attaching the roll core on the auto take-up reel, follow these steps to take up media with the printable side in.

1. Guide your loaded media over the media guide bar and behind the roll core, then attach the media to the roll core with tape as shown here.

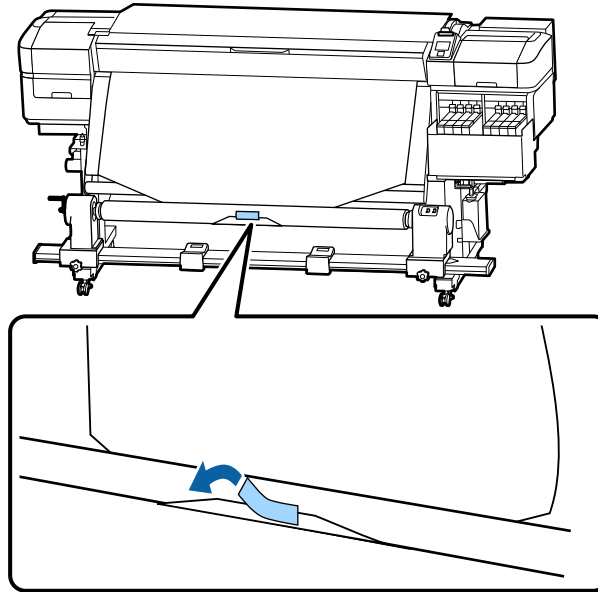

Note: Make sure the media lays flat across the roll core without any gaps. If necessary, add more tape or reattach the tape so the media is taken up correctly.

- 2. Press and hold the down arrow button on the control panel to feed enough media for it to wrap once around the roll core.

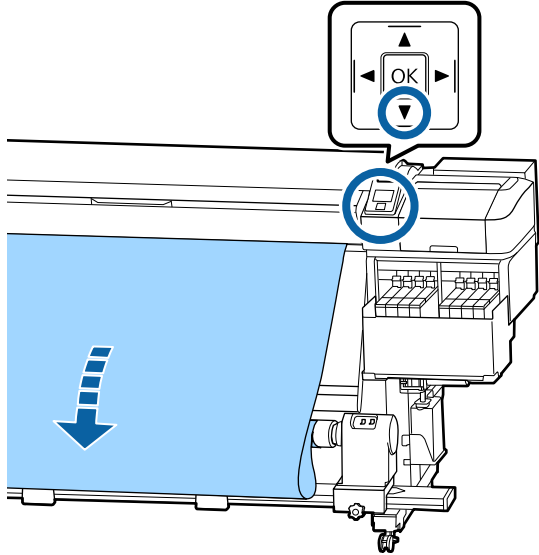

3. Confirm that the **Auto** switch on the auto take-up reel is set to the **off** position, then push and hold the **Manual** switch up to the  position to wind the media around the roll core.

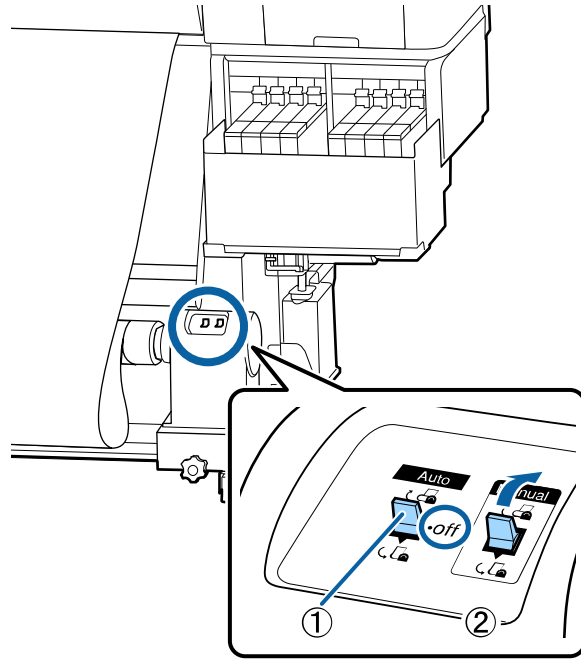

4. Move the **Auto** switch up to the  position.

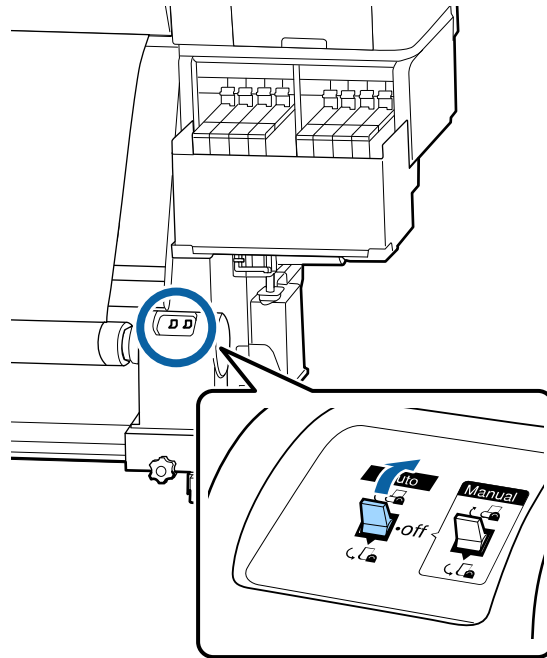

5. Make sure the media is taut and loads evenly on both sides.

Note: If the media is looser on one side than the other, the media cannot be taken up correctly. Repeat these steps to reload the media on the auto take-up reel.

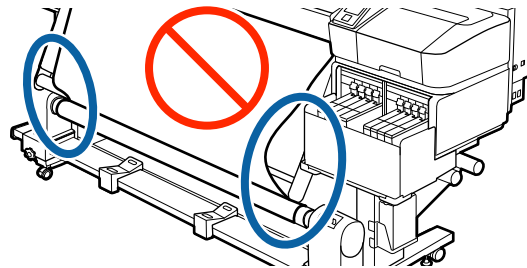

6. Confirm that the tension is even by lightly tapping the media on both sides as shown here.

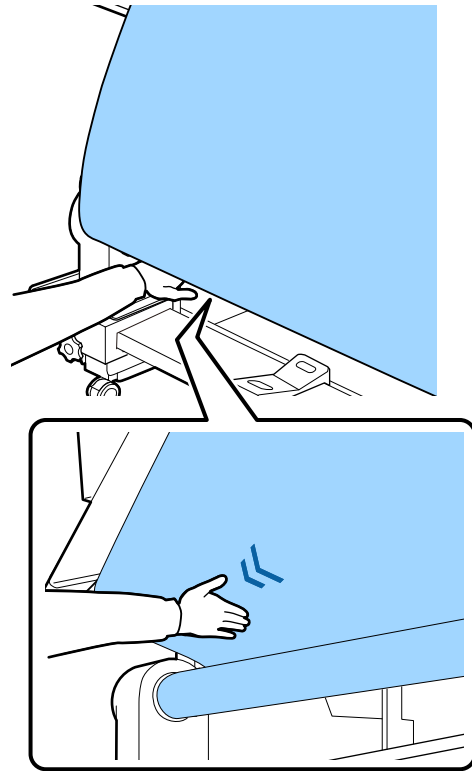

7. Press and hold the down arrow button on the control panel until the edges of the media are taken up and the media wraps once or twice around the roll core.

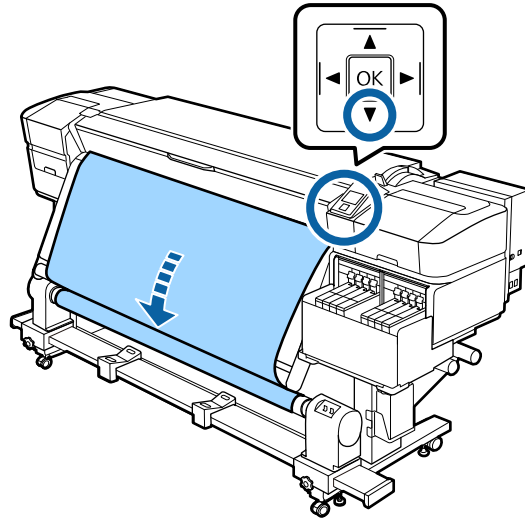

Parent topic: [Using the Auto Take-up Reel](#)

Take Up with the Printable Side Out

After attaching the roll core on the auto take-up reel, follow these steps to take up media with the printable side out.

1. Guide your loaded media over the media guide bar and the roll core, then attach the media to the roll core with tape as shown here.

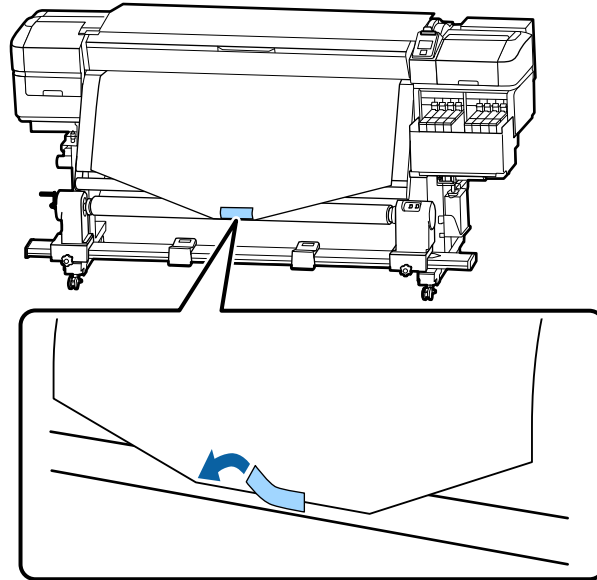

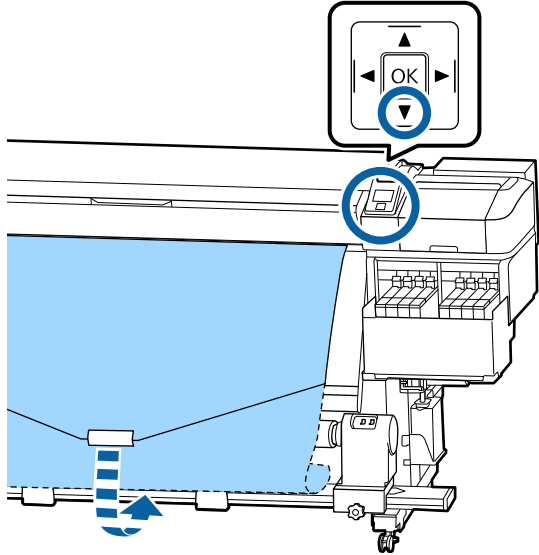

Note: Make sure the media lays flat across the roll core without any gaps. If necessary, add more tape or reattach the tape so the media is taken up correctly.

- 2. Press and hold the down arrow button on the control panel to feed enough media for it to wrap once around the roll core.

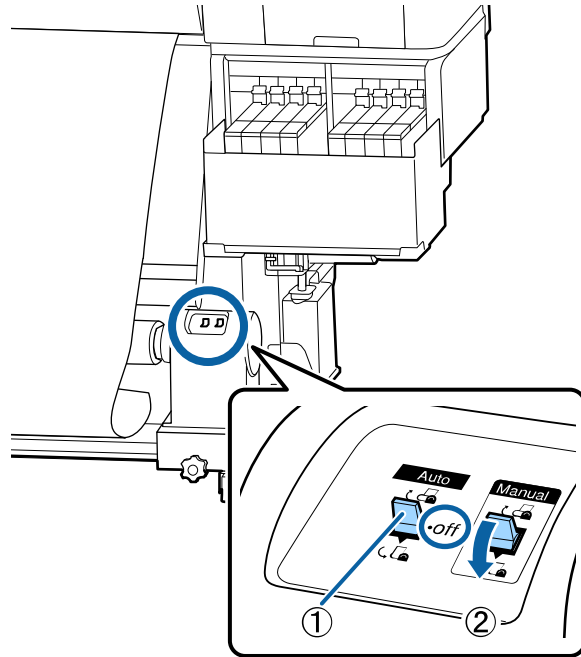

3. Confirm that the **Auto** switch is set to the **off** position, then push and hold the **Manual** switch down to the  position to wind the media around the roll core.



4. Move the **Auto** switch down to the  position.

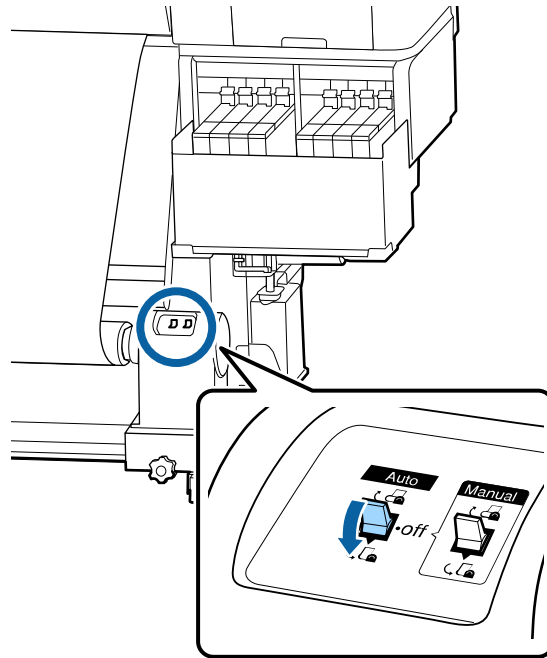

5. Make sure the media is taut and loads evenly on both sides.

Note: If the media is looser on one side than the other, the media cannot be taken up correctly. Repeat these steps to reload the media on the auto take-up reel.

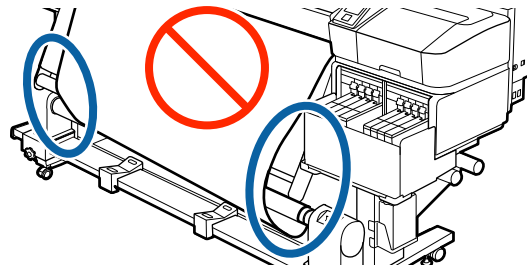

6. Confirm that the tension is even by lightly tapping the media on both sides as shown here.

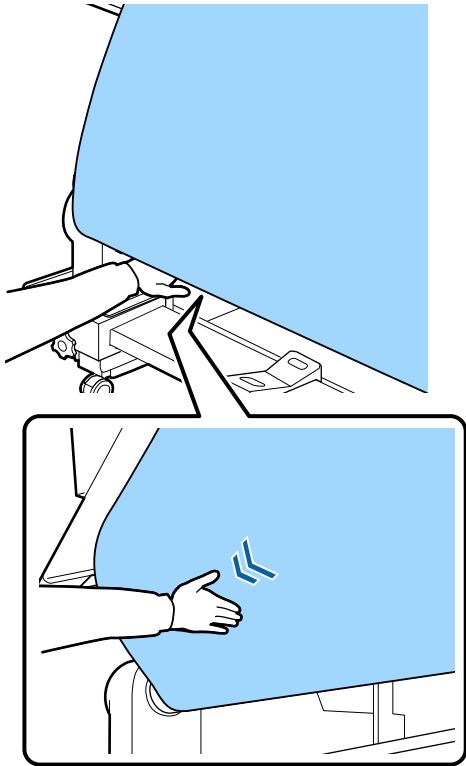

7. Press and hold the down arrow button on the control panel until the edges of the media are taken up and the media wraps once or twice around the roll core.

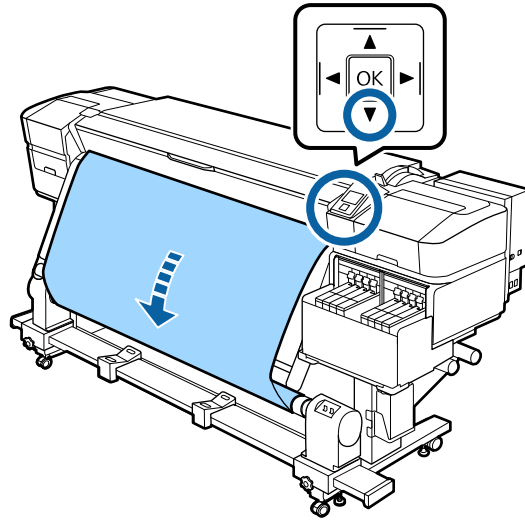

Parent topic: [Using the Auto Take-up Reel](#)

Removing Media from the Auto Take-up Reel

After printing on media loaded on auto take-up reel, follow these steps to remove it.

Note: Make sure the media is cut before removing it from the auto take-up reel.

1. Rotate the handle of the left roll core holder.

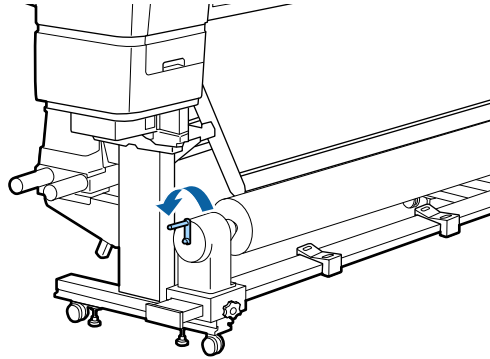

2. While supporting the left side of the media roll, loosen the left roll core holder locking screw and remove the roll core holder from the roll.

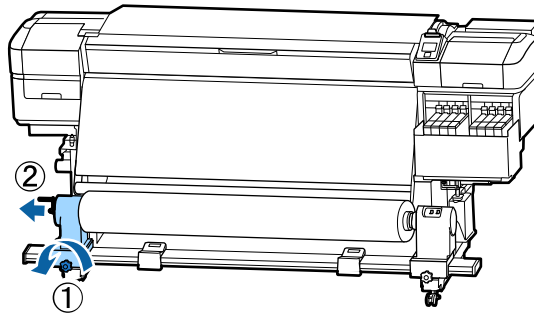

3. Lower the left side of the media roll onto the roll support.

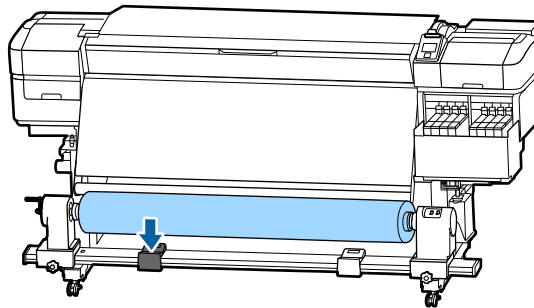

4. While supporting the right side of the media roll, loosen the right roll core holder locking screw and remove the roll core holder from the roll.

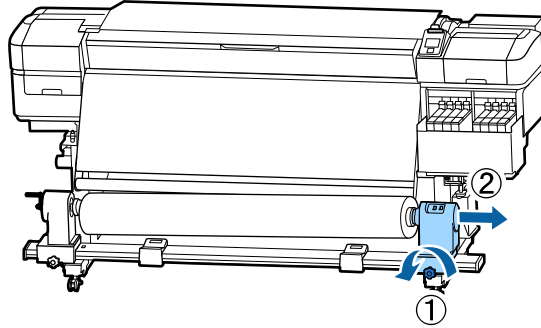

5. Lower the right side of the media roll onto the roll support.

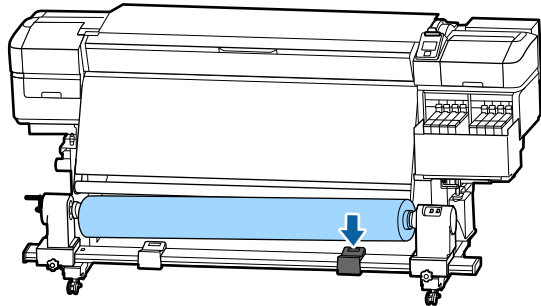

Parent topic: [Using the Auto Take-up Reel](#)

Related tasks

[Cutting Media](#)

Using the Control Panel Menus

Follow the instructions in these sections to access the printer menu system and select settings.

[Accessing the Printer's Menus](#)

[Media Setup Menu Settings](#)

[Printer Setup Menu Settings](#)

[Maintenance Menu Settings](#)

[Printer Status Menu Settings](#)

[Other Settings Menu Settings](#)

Accessing the Printer's Menus

You can use the printer menus to adjust the settings that control how your product works.

1. Press the **Menu** button on the control panel.

You see the menus on the LCD screen.

2. Press the up or down arrow button to scroll through the menus.

Note: Press the  back button to go back.

3. To change settings in the highlighted menu, press the **OK** button.
4. Press the up or down arrow button to move through the settings. Press the right or left arrow button to position the cursor when entering data on the screen.
5. To select a setting, press the **OK** button.
6. When you finish changing settings on a menu, press the  pause/cancel button to return to the main screen.

Parent topic: [Using the Control Panel Menus](#)

Media Setup Menu Settings

Settings on the Media Setup menu let you customize various adjustments for up to 30 different media types.

Caution: Follow the instructions in the topic links below the table to use these menu settings correctly.

Setting	Options	Description
Feed to Cut Position	—	Sends the end of the print to the cutting groove.
Easy Media Setup	1 to 30	Store new media settings.
Screen Display	Media Remaining	Displays the length of the remaining roll media in increments of 3.9 inches (0.1 m).
	Print Length	Displays the length per printed job in increments of 39.4 inches (1 m).
Media Remaining	Print Remaining Length	Prints the amount of media remaining on the current roll.
	Length	Enter the total roll length, from 3 to 1969 ft (1.0 to 600.0 m).
	Remaining Alert	Enter the length at which the printer will alert you to the amount of media remaining, from 4 to 50 ft (1 to 15 m).
Reset Print Length	Manual Reset	Resets the print length value to 0 when you press the OK button.
	Auto Reset	Select Per Job to reset the print length value to 0 for every new job. If you select Off , you must manually reset the value.
Customize Settings	Current Settings	Selects the current media setting to customize (see the next table).
	1 to 30	Selects a stored media setting to customize (see the next table).
Select Media	1 to 30	Selects a stored media setting to use for printing.

Customize Settings options

Setting	Options	Description
Setting Name	—	Enter a name up to 22 characters long for the group of media settings.
Media Type	Thinnest	Select for media 16 lb (60 g/m ²) or less.
	Thin	Select for media 17 to 22 lb (61 to 80 g/m ²).
	Thick	Select for media 23 to 32 lb (81 to 120 g/m ²).
	Thickest	Select for media 33 lb (121 g/m ²) or more.
	Adhesive	Select when using any weight of adhesive media.
Media Adjust	Auto Feed Adjustment	Select Print to perform an automatic feed adjustment.
	Manual	Select Feed Adjustment and select a pattern type (Standard , 100mm Pattern , 250mm Pattern , or 500mm Pattern). Select Head Alignment to adjust only the head alignment.
Advanced Settings	—	See the next table.
Restore Settings	—	Select Yes to return all settings for the selected media to their default values.

Advanced Settings options

Setting	Options	Description
Platen Gap	1.6	Select if print quality is unsatisfactory.
	2.0	Select for most media; default setting.
	2.5	Select only if printouts are scratched or smudged. Choosing a larger gap than necessary can cause ink stains inside the product, reduce print quality, or shorten product life.
Heating & Drying	Heater Temperature	Set from 86 to 131 °F (30 to 55 °C); defaults to 122 °F (50 °C).
	Drying Time Per Pass	Set from 0 to 10 seconds. You can maintain a constant drying time by basing it on the media width.
	Blank Area Feed	Speeds up feeding of blank areas. Select Quick , Standard , Slow , or Slowest .
	After Heater Feed	Select On to feed media to the after heater after printing (if the media will be cut before the next job starts).
Feeding Tension	Lv1 to Lv8	Increase the value if creases appear in media during printing.
Take-up Tension	Auto	Select for most media.
	Manual	Select a value from Lv1 to Lv9 . Decrease the value if creases appear in media during printing or ink adheres to the back of the take-up roll. Increase the value if thick media cannot be wound correctly.
Media Suction	0 to 10	Select a value to increase the gap between the print head and thin or flexible media. If print quality is reduced or media does not feed correctly, you may need to lower the value.

Setting	Options	Description
Head Movement	Data Width	Select to move the print heads within the range of the print data's width.
	Printer Full Width	Select to move the print heads within the range of the printer's maximum media width.
	Media Width	Select to move the print heads within the range of the width of the loaded media.
Multi-Strike Printing	Off	Disable the feature.
	2 to 8	Select the number of times each line is printed.
Feed Speed Limiter	On	Select if thin media wrinkles or tears easily (print speed decreases).
	Off	Select for normal printing.
Pressure Roller Load	Low	Select if there is wrinkling around the pressure rollers or stains on the roller to reduce pressure on the rollers.
	Medium	Select for normal printing.
	High	Select if using media with a slippery coating to increase pressure on the rollers.
Remove Skew	On	Select to perform skew correction for loaded media.
	Off	Select if media shows traces from the rollers.
Periodic CL Cycle	Auto	Select to let the product determine when to perform a head cleaning based on the selected media setting.
	Manual	Select to set the interval for head cleaning. You can choose from Printing Time or Media Usage .

Setting	Options	Description
Prevent Sticking	On	Select only if the media sticks to the platen when the printer is turned on or when printing starts.
	Off	Select for normal printing.
Reduce Print Streak	Off	Select for most print jobs.
	Light	If streaks appear in a printout, select one of the options to make streaks less evident.
	Medium	
	Heavy	

Parent topic: [Using the Control Panel Menus](#)

Related tasks

[Cutting Media](#)

[Loading Media](#)

[Saving Sets of Media Settings](#)

[Adjusting the Media Feed Automatically](#)

[Adjusting the Media Feed Manually](#)

[Adjusting Heating and Drying During Printing](#)

[Aligning the Print Head](#)

Printer Setup Menu Settings

The Printer Setup menu lets you control margin settings, automatic cleaning cycles, and other aspects of your product's operation.

Caution: Follow the instructions in the topic links below the table to use these menu settings correctly.

Setting	Options	Description
Margin Setting	Side Margin(Right)	Sets the width of the right or left margin from 0.12 to 1.00 inch (3 to 25 mm).
	Side Margin(Left)	
Print Start Position	0.00 to 32.00 inches (0 to 800 mm)	Sets an additional margin on the right side of the media.

Setting	Options	Description
Margin Between Pages	Normal No Margin	Sets a margin between pages.
Media Check	Media Size Check	Automatically detects the edges of the media. Select On unless the printer displays Media Size Error when media is loaded correctly. If you select Off , the printer may print beyond the edges of the media. Changes to the settings are applied after the media is reloaded.
	Media End Check	Automatically detects the end of the media. Select On unless the printer displays Media Out when media is loaded correctly.
	Media Skew Check	Stops printing and displays an error when skewed media is detected. Select On to avoid jams caused by skewed media.
Media End Option	Continue Stop Printing	Selects whether to continue an unfinished print job after a media roll is replaced.
Btw Pages Nozzle Check	Off Print Pattern (1 to 10 pages)	Selects how often to print an automatic nozzle check pattern between printed pages.
Lamp Setting	Auto Manual	Selects if the light inside the front cover turns on automatically. If you select Manual , press the  internal light button on the control panel to turn the light on or off.

Setting	Options	Description
Head Mode	2 Heads Mode Head1 Head2	Select 2 Heads Mode in most situations. If there is a clogged nozzle in a single print head that cannot be cleared after several head cleanings, you can continue printing by selecting one of the unclogged heads.
Sleep Mode	15 to 240 minutes	Sets the number of minutes of inactivity before the product enters sleep mode. Press any button on the control panel to resume operation.
Charge Settings	Extend Charge Timing Forced Charge	Adjusts the chip unit if there is a discrepancy between the estimated ink level indicator on the LCD screen and the actual amount of remaining ink.
Cleaning During Standby	When to Clean Cleaning Level	Sets the time (1 to 240 hours) to perform head cleaning and the strength level of cleaning when the product has not been in use.
Head Maint. Interval	20 to 400 m	Sets when to perform head maintenance after the selected length of media has been printed.
Restore Settings	Yes No	Returns all items in the Printer Setup menu to their default settings.

Parent topic: [Using the Control Panel Menus](#)

Related references

[Printable Area and Media Size Checking](#)

Related tasks

[Cleaning the Print Head](#)

[Checking for Clogged Print Head Nozzles](#)

Maintenance Menu Settings

The Maintenance menu lets you run nozzle checks, cleaning cycles, and other maintenance operations. You can access the menu directly by pressing the  maintenance button.

Caution: Follow the instructions in the topic links below the table to use these menu settings correctly.

Setting	Options	Description
Nozzle Check	Print At Right Print At Center Print At Left	Prints a nozzle check pattern in the specified location on the media.
Cleaning	Cleaning (Light) Cleaning (Heavy) Preventive Cleaning	Lets you clean all or selected nozzles, based on the nozzle check pattern. Select the light cleaning level first. If nozzles are still clogged, select the heavy cleaning level. If you anticipate automatic or periodic head cleaning will occur during a print job, select Preventive Cleaning to avoid the cleaning and continue the print job.
Head Maintenance	Auto Head Maintenance	Select Execute if nozzles are still clogged after head cleaning.
	Regular Cleaning	Select Move Head to position the print heads for cleaning.
Replace Ink Bottle	—	View instructions on how to replace the waste ink bottle on the LCD screen.
Head Cleaning Set	—	View information about the head cleaning set on the LCD screen.
Other Maintenance	Grease Carriage Rod	Select Yes if a message to apply carriage rod grease appears on the LCD screen.

Parent topic: [Using the Control Panel Menus](#)

Related tasks

[Checking for Clogged Print Head Nozzles](#)

[Cleaning the Print Head](#)

[Replacing the Waste Ink Bottle](#)

[Replacing the Head Cleaning Set](#)

[Applying Carriage Rod Grease](#)

Printer Status Menu Settings

The Printer Status menu displays the printer's firmware version number.

Parent topic: [Using the Control Panel Menus](#)

Other Settings Menu Settings

The Other Settings menu includes network settings and other preferences you can customize.

Setting	Options	Description
Network Setup	IP Address Setting	Determines whether IP addresses are obtained automatically through DHCP or manually. Select Panel to enter an IP address, subnet mask, and default gateway address.
	Print Status Sheet	Prints the current network status and settings.
	Restore Settings	Select Yes to restore all the Network Setup settings to their defaults.
Preferences	Date And Time	Sets the printer's built-in clock. The time and date are used in logs and status sheets.
	Language	Selects the language used on the control panel display.
	Units	Selects length or temperature units displayed on the LCD screen or printed test patterns.

Setting	Options	Description
Alert Sound Setting	On	Enables the alert sound when an error occurs.
	Off	
Alert Lamp Setting	On	Enables the alert light when an error occurs.
	Off	
Reset All Settings	Yes	Resets all settings (except in the Preferences menu) to their defaults.
	No	

Parent topic: [Using the Control Panel Menus](#)

Maintenance

See the instructions in these sections to maintain your printer for optimum results.

[When to Maintain Your Product](#)

[Preparing for Maintenance](#)

[Stirring High Density Black Ink](#)

[Replacing the Ink and Chip Unit](#)

[Print Head Maintenance](#)

[Cleaning Around the Print Heads](#)

[Cleaning the Anti-drying Caps](#)

[Cleaning the Platen and Media Edge Guides](#)

[Cleaning the Heat Shield](#)

[Replacing the Waste Ink Bottle](#)

[Replacing the Head Cleaning Set](#)

[Replacing the Media Edge Guides](#)

[Applying Carriage Rod Grease](#)

When to Maintain Your Product

See the guidelines here to determine when you perform maintenance operations on your product or replace or refill consumables. If you need to perform an operation, use the links at the end of this topic.

Caution: To prevent sedimentation and incorrect colors in your printouts, stir the High Density Black ink in the ink tank once a week.

Note: You can set up certain maintenance operations to run automatically using settings on your product control panel.

Symptom	Maintenance or consumable operation
A low ink warning appears on the LCD screen.	Check if you need to replace an ink and chip unit for the indicated color.
A prepare and replacement message appears on the LCD screen.	Replace the waste ink bottle.

Symptom	Maintenance or consumable operation
A message on the LCD screen tells you to apply carriage rod grease.	Apply carriage rod grease to the carriage rods.
You want to check the print quality for clogged nozzles.	Run a nozzle check to print a check pattern.
A nozzle check pattern indicates clogged nozzles.	Clean the print head.
Print quality has declined.	
Printed media is faint, or contains horizontal stripes or uneven colors.	
Even after cleaning the print head several times, print quality has declined.	Perform the following as necessary: <ul style="list-style-type: none"> • Clean around the print heads. • Clean the anti-drying caps.
Printed media is smudged.	
Ink, paper particles, or lint from the media accumulate on the platen or media edge guides.	Clean the platen and media edge guides as necessary.
Ink adheres to the heat shield.	Clean the heat shield.
The media edge guides are deformed or damaged.	Replace the media edge guides.
A message on the LCD screen tells you the head cleaning set is nearing the end of its life.	Replace the head cleaning set.

Parent topic: [Maintenance](#)

Related tasks

[Replacing the Chip Unit and Refilling Ink](#)

[Replacing the Waste Ink Bottle](#)

[Applying Carriage Rod Grease](#)

[Checking for Clogged Print Head Nozzles](#)

[Cleaning the Print Head](#)

[Cleaning Around the Print Heads](#)

[Cleaning the Anti-drying Caps](#)

[Cleaning the Platen and Media Edge Guides](#)

[Cleaning the Heat Shield](#)

[Replacing the Media Edge Guides](#)

Preparing for Maintenance

Before you perform any maintenance procedures, see these sections to prepare for maintenance.

[Maintenance Supplies](#)

[Maintenance Precautions](#)

[Using Ink Cleaner](#)

[Moving the Print Head for Maintenance](#)

Parent topic: [Maintenance](#)

Maintenance Supplies

Before performing any maintenance tasks or replacing ink, make sure you have the maintenance supplies listed here.

Protective eyewear

Obtain commercially available eyewear to protect your eyes from ink and ink cleaner.

Mask

Obtain a commercially available mask to protect your mouth and nose from ink and ink cleaner.

Maintenance tools

Use the maintenance tools that came with your product for general cleaning.

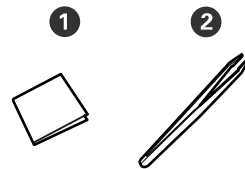

Number	Part	Quantity
1	Cleaning wipes	100
2	Tweezers	1

Maintenance Kit

Use the maintenance kit that came with your product for cleaning ink stains. The kit contains the following items:

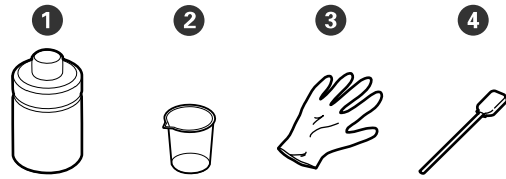

Number	Part	Quantity
1	Ink cleaner	1
2	Cup	1
3	Gloves	12
4	Cleaning stick	25

Metal tray

Use the tray that came with your product to hold cleaning tools and removed consumables.

Soft cloth

Obtain a commercially available static-free, lint-free soft cloth to clean inside the product.

Grease Kit

Use the grease kit that came with your product to apply grease to the carriage rods.

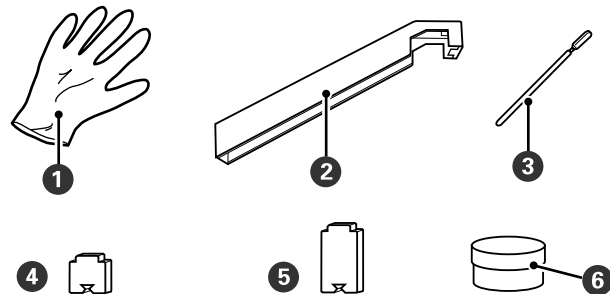

Number	Part	Quantity
1	Gloves	16
2	Grease tool	1
3	Cleaning stick	8
4	Pad A	16
5	Pad B	16
6	Secondary carriage rod grease	2

Parent topic: [Preparing for Maintenance](#)

Related references

[Consumables and Replacement Parts](#)

Maintenance Precautions

Follow these precautions as you maintain your product:

- Remove loaded media from the product before performing any maintenance tasks.
- Touch a metal object to discharge any static electricity before performing any maintenance tasks.
- Never touch the belts, cables, circuit boards, or other parts not covered in the maintenance task steps or you could adversely affect the print quality or damage your product.
- Use only the cleaning sticks included in the product maintenance kit to clean your product to avoid damaging the print head.
- Do not reuse cleaning sticks.
- Do not touch the ends of the cleaning sticks to prevent oil from your hands from damaging the print head.
- Do not use alcohol or water to clean the nozzle surface, caps, or wiper or you may damage your product.
- Store ink packs, secondary carriage rod grease, and waste ink out of the reach of children.
- Wear protective eyewear, gloves, and a mask when performing maintenance tasks.
- Wash your hands after performing maintenance.

Warning: If ink, waste ink, ink cleaner, or secondary carriage rod grease contact your skin, or get into your eyes or mouth, immediately do the following:

- Thoroughly wash the substance from your skin with soapy water. If your skin becomes irritated or discolored, contact a doctor.
- Immediately rinse the substance from your eyes with water to avoid bloodshot eyes or mild inflammation. If you experience eye problems, contact a doctor.
- If a substance gets in your mouth, contact a doctor immediately.
- If you swallow a substance, do not induce vomiting and contact a doctor immediately. Inducing vomiting may cause material to get in your windpipe and cause injury.

Parent topic: [Preparing for Maintenance](#)

Related references

[Maintenance Supplies](#)

Using Ink Cleaner

Use the ink cleaner and cup that came in the maintenance kit to clean only when instructed to. Whenever you use the ink cleaner, follow the steps here.

Caution: Using ink cleaner on any other parts of your product could damage the product.

Be sure to do the following:

- Store ink cleaner at room temperature and out of direct sunlight.
- Use fresh ink cleaner with a fresh cleaning stick each time; do not reuse them.
- Dispose of used cleaning sticks and ink cleaner according to local disposal regulations.

1. Place the cup on a tray and pour approximately 0.3 ounce (10 ml) of ink cleaner into the cup.

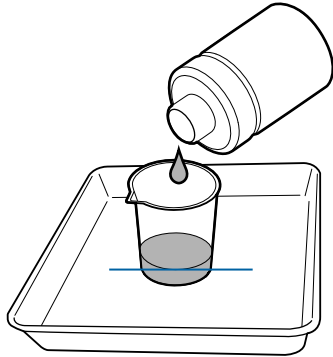

2. Recap the ink cleaner bottle.
3. Dip a fresh cleaning stick into the ink cleaner and let any excess cleaning solution drip into the cup.

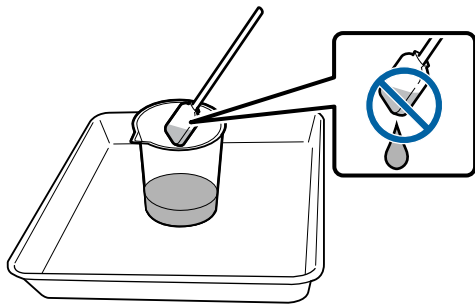

Parent topic: [Preparing for Maintenance](#)

Related references

[Maintenance Supplies](#)

Moving the Print Head for Maintenance

Certain maintenance tasks require that you move the print head as described here before performing the task.

Caution: Always move the print head as described here. Do not move the print head manually or you may cause your product to malfunction.

1. When the product is turned on, press the **M** maintenance button on the control panel.
You see the **Maintenance** menu.
2. Press the down arrow button to select **Head Maintenance** and press the **OK** button.
3. Press the down arrow button to select **Regular Cleaning** and press the **OK** button.
The print head moves into maintenance position.
4. Perform your maintenance task as necessary.

Note: After 10 minutes, an alarm sounds to warn you that the print head is still in the maintenance position. You also see a notice on the LCD screen telling you to clean the print heads after maintenance. After completing your maintenance task, press the **OK** button to clean the print heads. The alarm sounds again at 10 minute intervals if the print heads are not in the home position.

Parent topic: [Preparing for Maintenance](#)

Related references

[Maintenance Menu Settings](#)

Stirring High Density Black Ink

To prevent sedimentation and incorrect colors in your printed media, stir the High Density Black ink in the ink tank once a week.

1. Open the ink inlet cover for the High Density Black ink shown here.

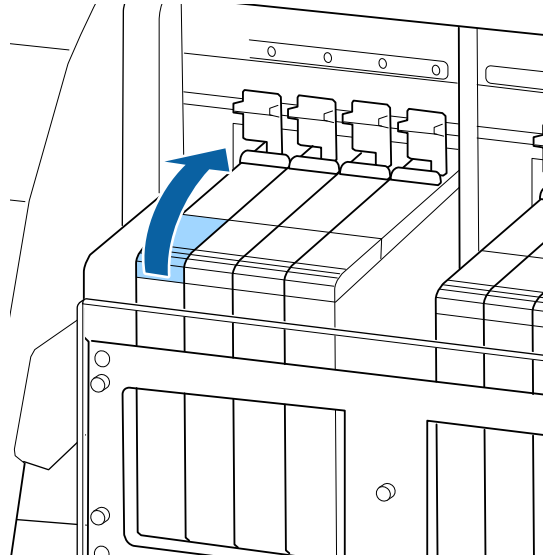

2. Grasp the loop at the top of the ink inlet cap and slowly remove the ink inlet cap.

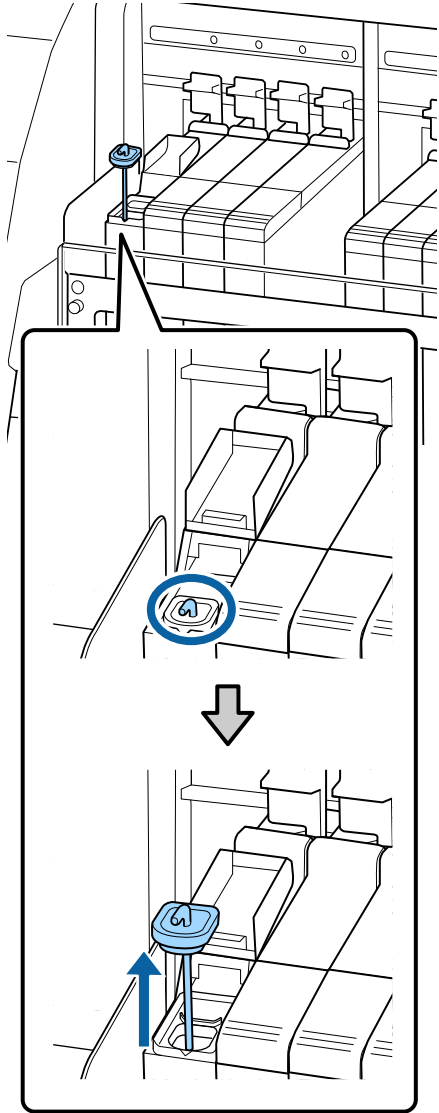

3. Move the stirring stick up and down 15 times. Insert the stick completely into the ink tank and raise the stick up to the top each time.

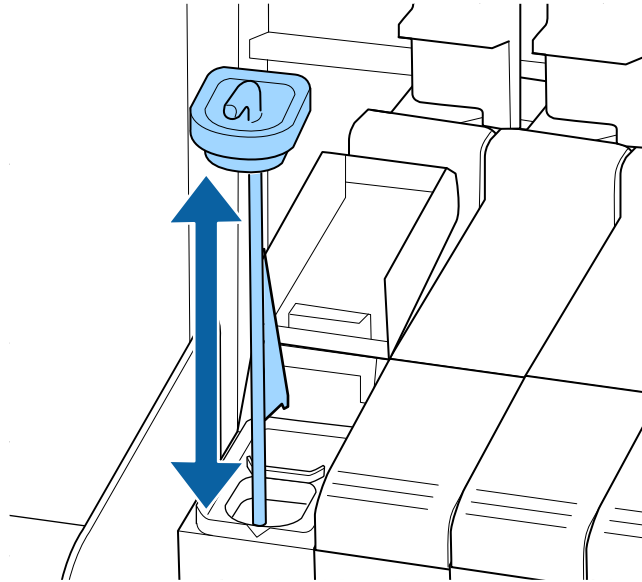

Caution: Move the stick slowly and steadily, or ink may splatter.

4. Insert the stirring stick into the ink tank and replace the ink inlet cap

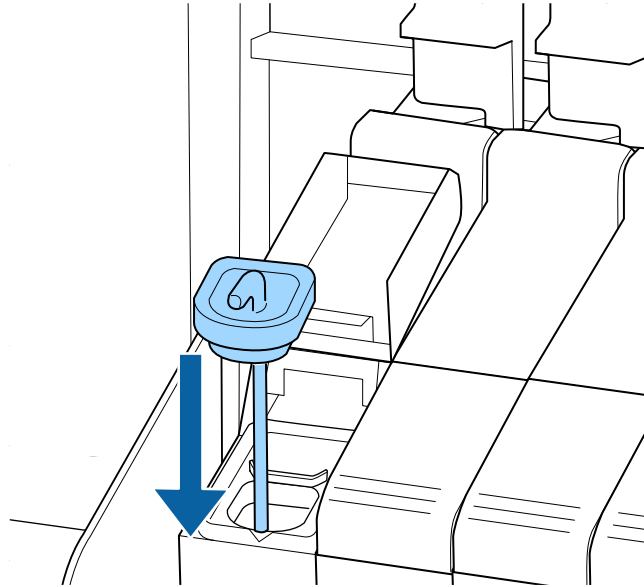

Caution: Press the ink inlet cap down firmly. If the slider comes into contact with the ink inlet cap when pulling it out, the cap could get damaged.

5. Close the ink inlet cover.

Parent topic: [Maintenance](#)

Replacing the Ink and Chip Unit

See these sections to replace the ink chip unit in your product.

[About Ink and Chip Unit Replacement](#)

[Ink and Chip Unit Precautions](#)

[Replacing the Chip Unit and Refilling Ink](#)

Parent topic: [Maintenance](#)

Related references

[Consumables and Replacement Parts](#)

About Ink and Chip Unit Replacement

When the message **Check Ink Levels** is displayed on the LCD screen, you need to refill the ink and replace the chip unit soon. Obtain an ink pack of the appropriate color as soon as possible.

You will be unable to print if a chip unit needs to be replaced. If the **Check Ink Levels** message is displayed during a print job, the print job pauses while you refill the ink and replace the chip unit. You can use the same procedure to refill the ink and replace chip units for all colors.

Note: When the message **Refill Ink Tank** is displayed on the LCD screen and the remaining ink level is greater than 2.8 in. (70 mm) from the base of the ink tank, it is time to replace the ink tank. The ink tank must be replaced because fine dirt, dust, and other foreign material causes the ink tank's filter to malfunction. The ink tank replacement interval depends on the usage environment and conditions. Contact Epson Support for information on replacing components.

Note: Your product has a remaining ink warning system. This system does not directly detect the amount of ink remaining in the ink tank. Instead, the amount of ink remaining is estimated based on the ink usage conditions and displayed as a message. The accuracy of this system depends on consistent and proper ink refills.

If the procedure for replacement and ink refilling here is not followed correctly, the remaining ink warning system may not function properly. To prevent this, replace the chip unit and refill the ink as soon as possible once the remaining ink level falls below 2.8 inches (70 mm) from the base of the ink tank.

Parent topic: [Replacing the Ink and Chip Unit](#)

Related tasks

[Replacing the Chip Unit and Refilling Ink](#)

Ink and Chip Unit Precautions

Follow these precautions as you refill the ink in your product:

- Store ink packs in a location out of the reach of children.
- Wear protective eyewear and gloves when refilling ink.
- Be sure to read the Safety Data Sheet (SDS) before using ink packs. To download it, visit epson.com/support/sds (U.S.) or epson.ca/support/sds (Canada) and select your product.
- Gently cut or tear off the ink pack spout seal. If you cut the ink pack spout seal too quickly, ink may splatter.
- Do not squeeze open ink packs. Ink may spill.
- Gently tilt the ink pack when pouring ink into the ink tank.

- Do not place anything on the ink tank or subject it to strong impacts, or the ink tank could detach.
- Do not switch between High Density Black ink and Black inks in the same ink tank. You must contact Epson Support to have a service engineer replace the type of ink being used in an ink tank.
- Epson recommends the use of genuine Epson ink packs.
- Epson cannot guarantee the quality or reliability of non-genuine ink. The use of non-genuine ink may cause damage that is not covered by Epson's warranties, and under certain circumstances, may cause erratic printer behavior.
- Information about non-genuine chip unit status may not be displayed, and use of non-genuine ink is recorded for possible use in service support.

Warning: Should ink contact your skin or enter your eyes or mouth, immediately take the following actions:

- If fluid contacts your skin, immediately wash it off using large volumes of soapy water. Consult a physician if the skin appears irritated or discolored.
- If fluid enters your eyes, rinse them immediately with water. Failure to observe this precaution could result in bloodshot eyes or mild inflammation. If problems persist, consult with a physician.
- If swallowed, do not induce vomiting and consult with a physician immediately. Inducing vomiting may cause material to get in your windpipe and cause injury.

Parent topic: [Replacing the Ink and Chip Unit](#)

Replacing the Chip Unit and Refilling Ink

Follow the steps here to replace the chip unit and refill the ink in your product.

1. When the message **Check Ink Levels** appears on the LCD screen, use the scale on the ink pack to check how much ink is left in the ink tank.

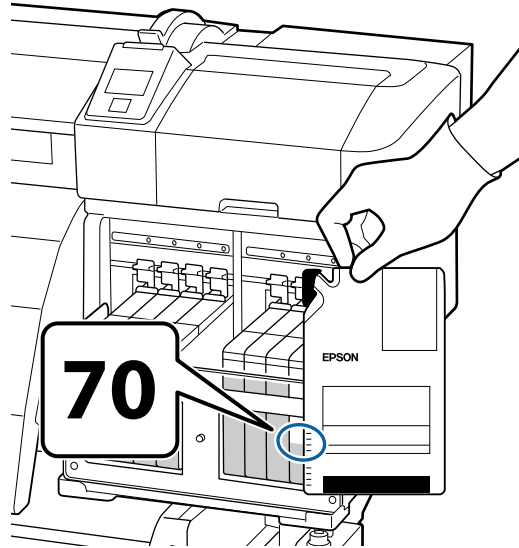

If the remaining ink level is greater than 2.8 in. (70 mm) from the base of the ink tank, continue to use the printer until the remaining ink level is 2.8 in. (70 mm) from the base of the ink tank so that you can use all the ink in a new ink pack to refill the ink tank.

If the remaining ink level is 2.8 inches (70 mm) or less, go to the next step.

Note: When the message **Refill Ink Tank** is displayed on the control panel screen and the remaining ink level is greater than 2.8 in. (70 mm) from the base of the ink tank, it is time to replace the ink tank. The ink tank must be replaced because fine dirt, dust, and other foreign material causes the ink tank's filter to malfunction. The ink tank replacement interval depends on the usage environment and conditions. Contact Epson Support for information on replacing components.

2. Lift the lock lever for the slider of the chip unit you intend to replace.

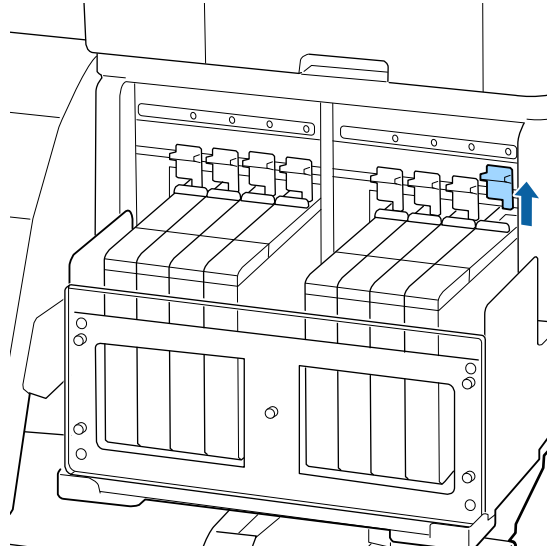

3. Insert a finger into the groove on the top of the slider and pull the slider straight out.

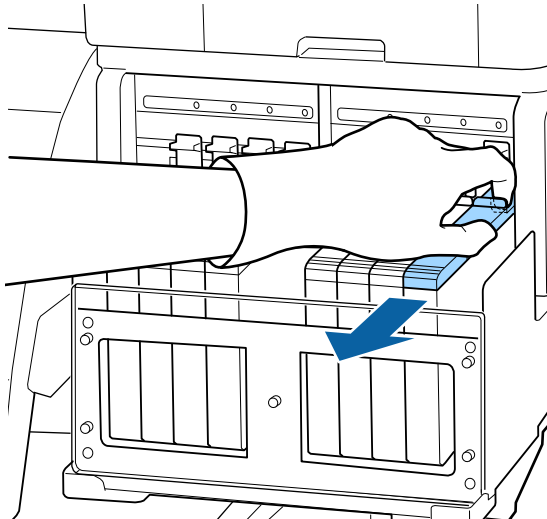

Caution: Do not tilt the slider. If you drop the chip unit, it may break.

4. Remove the chip unit from the slider.

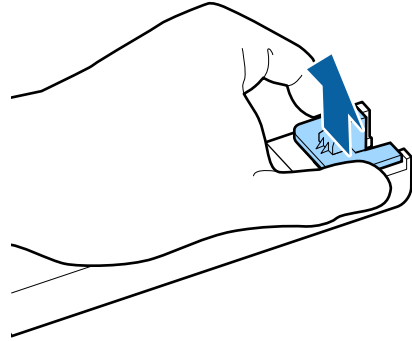

5. Confirm that the label color on the slider matches the label on the new ink pack. Then attach the chip unit supplied with the new ink pack to the slider.

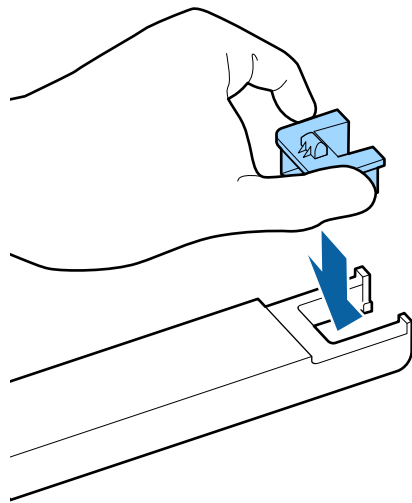

6. Hold the slider level and insert it. Lower the lock lever.

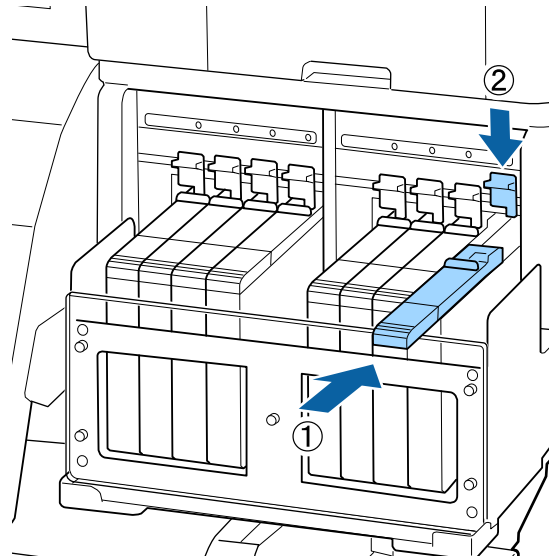

Caution: Do not push the slider in with too much force. Failure to observe this precaution could damage the printer.

7. Shake the new ink pack horizontally approximately 2 inches (5 cm) left and right for 5 seconds (approximately 15 times).

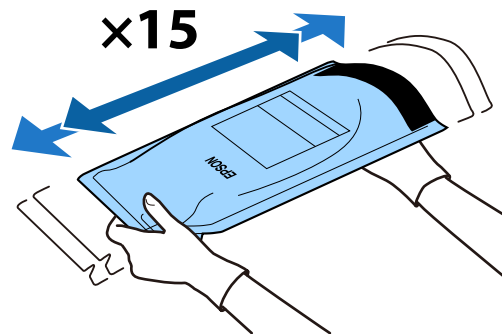

8. Open the ink inlet cover.

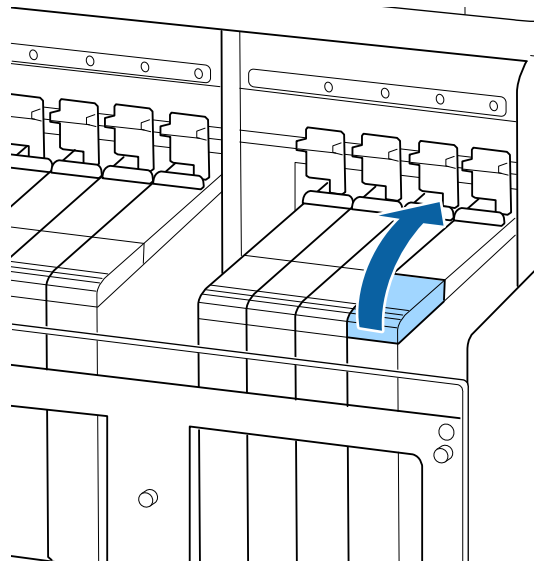

9. Do the following:

- For all ink colors except High Density Black ink, remove the ink inlet cap from the ink tank.

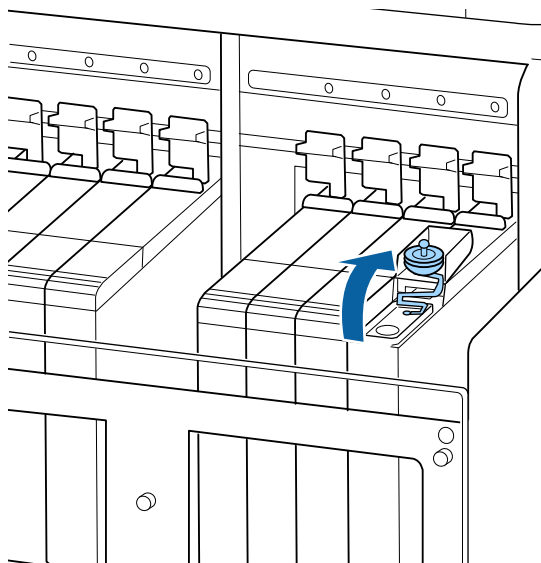

- For the High Density Black ink, grasp the loop at the top of the ink inlet cap and slowly remove the ink inlet cap.

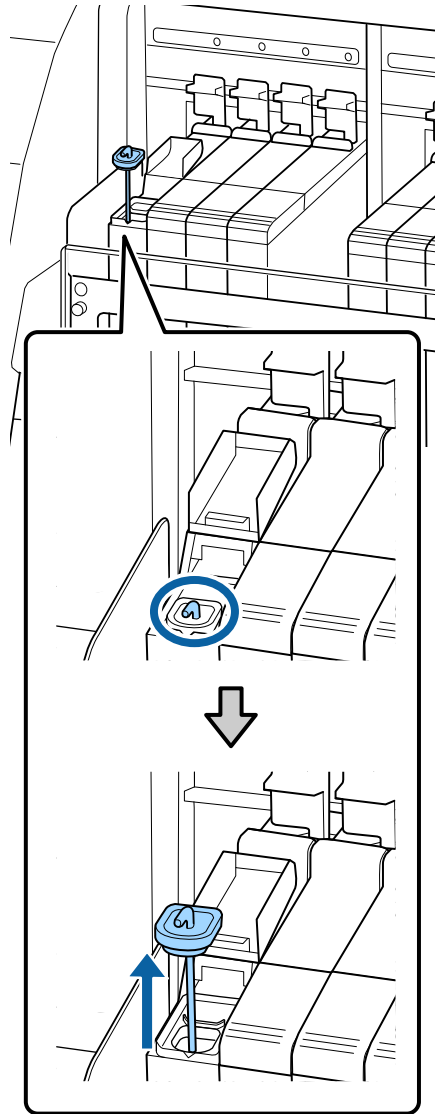

Rest the stirring stick on the tab at the edge of the tank as shown.

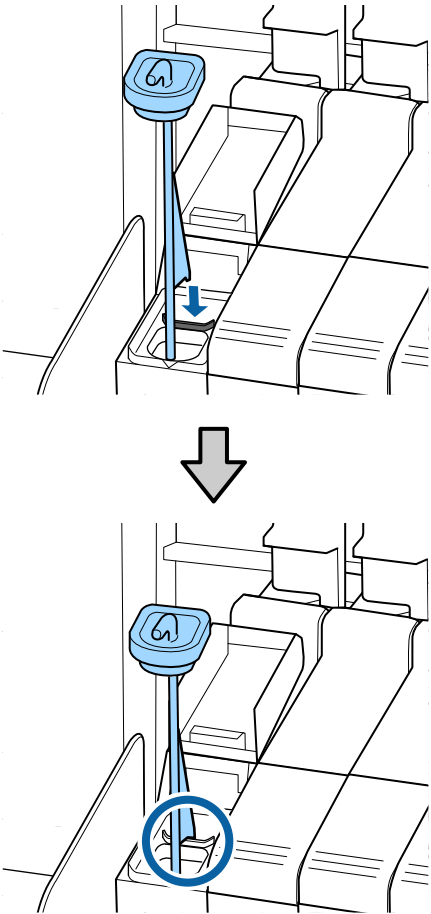

10. Cut or tear off the ink pack spout seal.

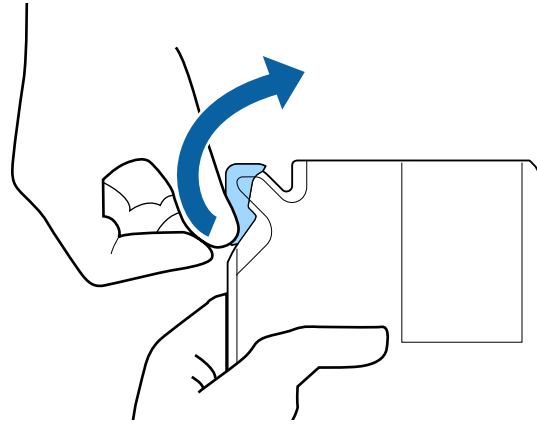

11. Insert the spout of the ink pack into the groove and slowly tilt it to pour the ink.

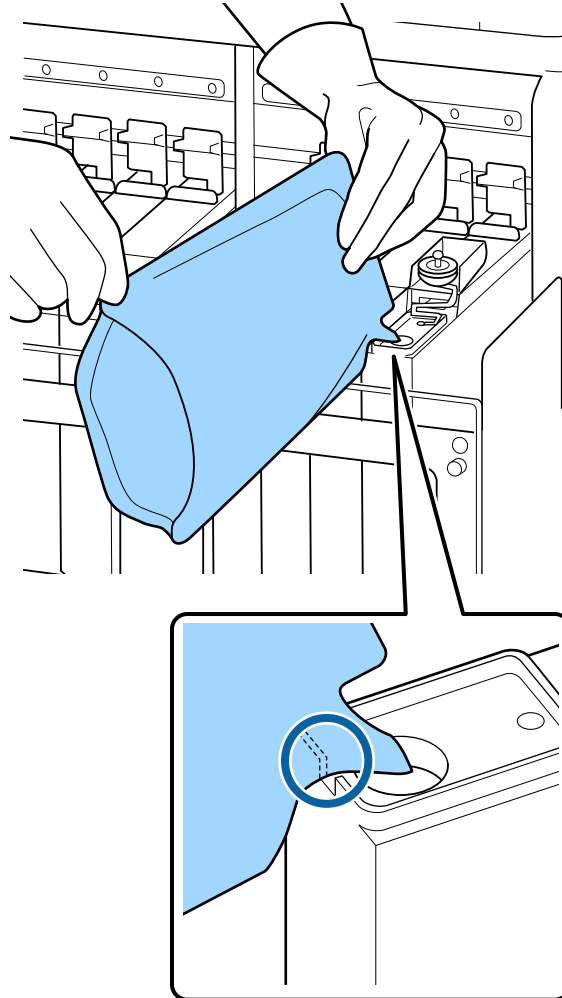

Note: Be sure to completely empty the ink pack into the tank. Do not use an ink pack to refill multiple ink tanks. This can prevent the proper display of messages from the remaining ink warning system.

12. Do the following:

- For all ink colors except High Density Black ink, replace the ink inlet cap.

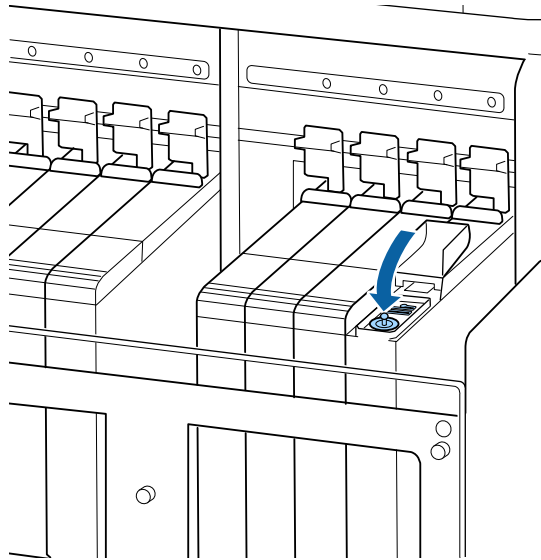

- For the High Density Black ink, lift up the stirring stick, guide it into the ink tank, and replace the ink inlet cap as shown.

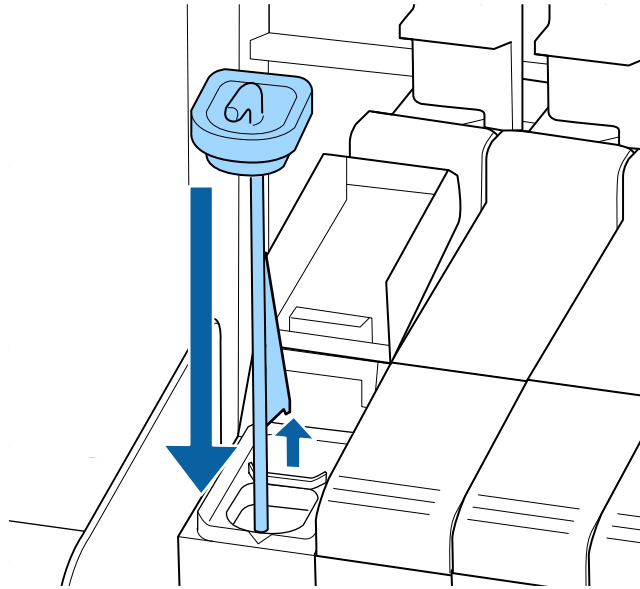

Caution: Press down the ink inlet cap firmly so it does not interfere with the slider and damage the ink inlet cap.

13. Close the ink inlet cover.

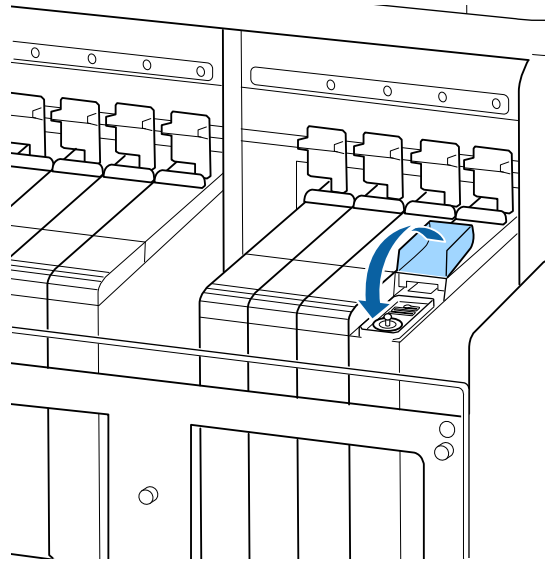

Note: If ink adheres to the heat shield, clean the heat shield.

Parent topic: [Replacing the Ink and Chip Unit](#)

Related concepts

[About Ink and Chip Unit Replacement](#)

Related references

[Ink and Chip Unit Precautions](#)

[Consumables and Replacement Parts](#)

[Where to Get Help](#)

Print Head Maintenance

Print head maintenance ensures the best print quality.

Perform the following maintenance as necessary:

- **Nozzle Check:** Check for clogged nozzles before each print job or if you have not used the printer for an extended period of time. Inspect the printed check pattern and clean the print head if you notice faint or missing areas.
- **Head Cleaning:** Clean the print head if you notice faint areas or gaps in the printed result.

[Checking for Clogged Print Head Nozzles](#)

[Cleaning the Print Head](#)

Parent topic: [Maintenance](#)

Checking for Clogged Print Head Nozzles

To maintain optimum print quality, perform a nozzle check before printing. This lets you visually inspect the printed check pattern and clean the nozzles, if necessary. There are two ways to check the nozzles:

- Set up the product to automatically print a check pattern before each print job. You can select how often the product performs a nozzle check in the **Printer Setup** menu.
- Manually run a nozzle check from the product control panel, as described here.

1. Press the  maintenance button.

You see the **Maintenance** menu.

2. Press the **OK** button to select **Nozzle Check**.
3. Press the up or down arrow button to select a print position for the check pattern and press the **OK** button.

The product prints a nozzle check pattern.

4. Check the printed pattern to see if there are gaps in the lines.

Nozzles are clean

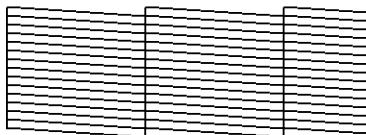

Nozzles need cleaning



5. If there are no gaps, the print head is clean and you can continue printing.

If there are gaps or the pattern is faint, clean the print head.

Parent topic: [Print Head Maintenance](#)

Related references

[Printer Setup Menu Settings](#)

[Maintenance Menu Settings](#)

Related tasks

[Loading Media](#)

[Cleaning the Print Head](#)

Cleaning the Print Head

If printouts are faint or have gaps, you should clean the print head to clear the clogged nozzles. Clean the print head only if print quality declines or image colors are incorrect. You can clean the print head when printing is paused, if necessary, but the colors in your printout may change when you resume printing.

Note: You can also set up the product to automatically clean the print head at selected intervals using the **Periodic CL Cycle** setting in the **Media Setup** menu.

You can select from two levels of head cleaning:

- **Cleaning (Light):** Use this cleaning level first.
- **Cleaning (Heavy):** Use this cleaning level if you cannot clear the clogged nozzles after cleaning with the light level.

Note: If colors are faint or missing even after cleaning the print head, manually clean around the print head inside the product.

1. Press the  maintenance button on the control panel.
You see the **Maintenance** menu.
2. Press the down arrow button to select **Cleaning** and press the **OK** button.
3. Press the up or down arrow button to select a cleaning level and press the **OK** button.
4. Press the up or down arrow button to choose one of the following cleaning options:
 - **All Nozzles**: Select this option when you see faint printing or gaps in all rows of nozzles in the check pattern.
 - **Selected Nozzles**: Select this option when you see faint printing or gaps in only certain rows of nozzles in the check pattern. You can select to clean multiple nozzle rows, if necessary. Continue to step 5.
5. To select the nozzle rows for cleaning, press the up or down arrow button to highlight the row number and press the **OK** button. Repeat for each row you want to clean. When you finish, select **Execute With Selection** and press the **OK** button.

Print head cleaning starts. When it is complete, the menu closes.

Note: If you paused printing to clean the print head, printing resumes when cleaning is finished.

6. Print a nozzle check pattern or check your printout to confirm that the nozzles are cleared.

Parent topic: [Print Head Maintenance](#)

Related references

[Printer Setup Menu Settings](#)

[Maintenance Menu Settings](#)

Related tasks

[Checking for Clogged Print Head Nozzles](#)

Cleaning Around the Print Heads

Clean around the print heads to remove any ink, lint, or dust that could affect print quality.

1. Before you clean around the print heads, move the print heads into maintenance position.

2. Open the left maintenance cover.

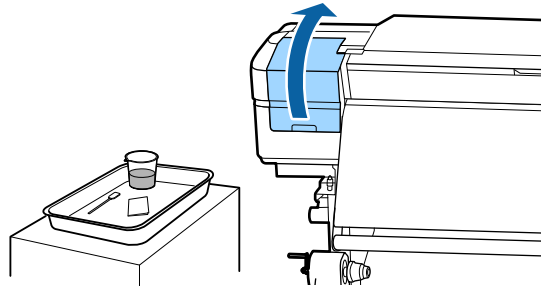

3. Dampen a new cleaning stick with ink cleaner.
4. Using the cleaning stick, wipe off any ink, lint, or dust from the parts shown. Wipe in the direction of the arrow around both print heads.

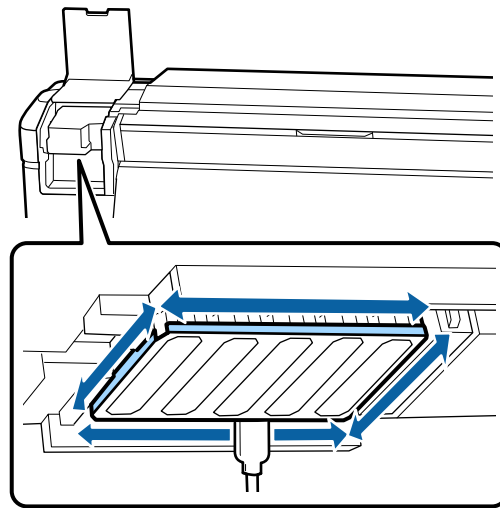

Caution: Do not move the cleaning stick back and forth; wipe in only one direction.

5. Wipe off any ink, lint, or dust from the areas shown.

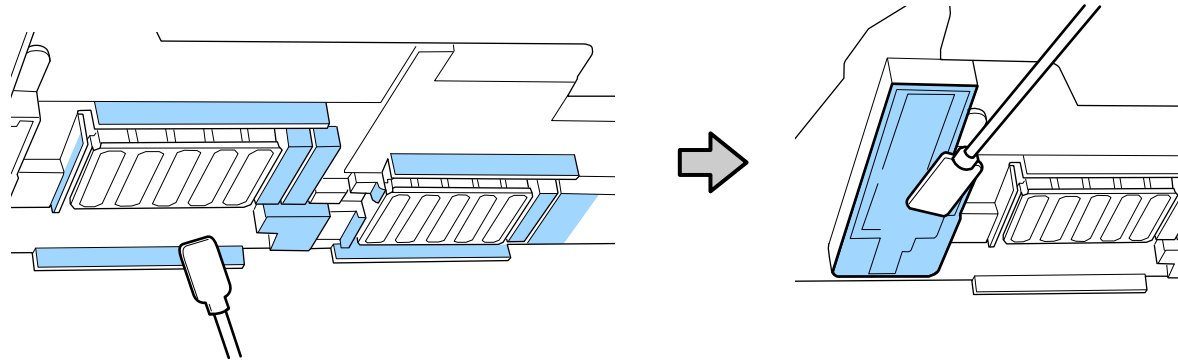

6. Close the left maintenance cover.

Parent topic: [Maintenance](#)

Related references

[Maintenance Supplies](#)

[Maintenance Precautions](#)

Related tasks

[Moving the Print Head for Maintenance](#)

Cleaning the Anti-drying Caps

Clean the anti-drying caps to remove any ink that may affect print quality.

1. Open the right maintenance cover.

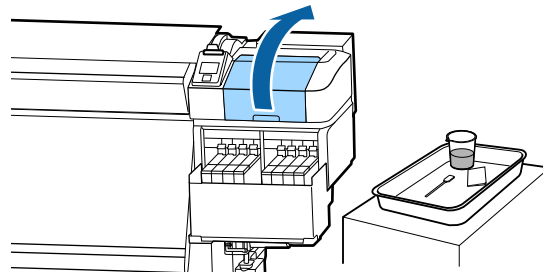

2. Dampen a new cleaning stick with ink cleaner.
3. Hold a cleaning stick flat and wipe the tops of the edges of the caps.

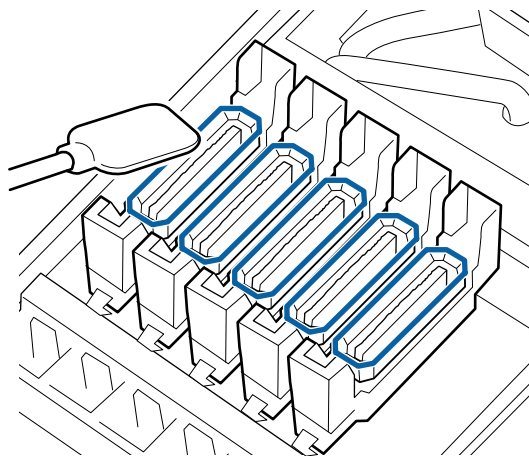

Note: Do not touch the inside of the caps shown here to avoid damaging the caps and preventing the print head from capping correctly.

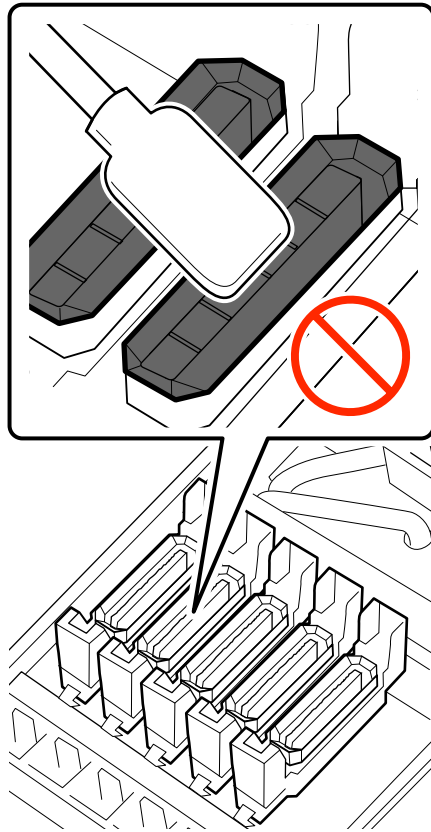

4. Hold a cleaning stick perpendicularly and wipe off any ink around the outsides of the caps.

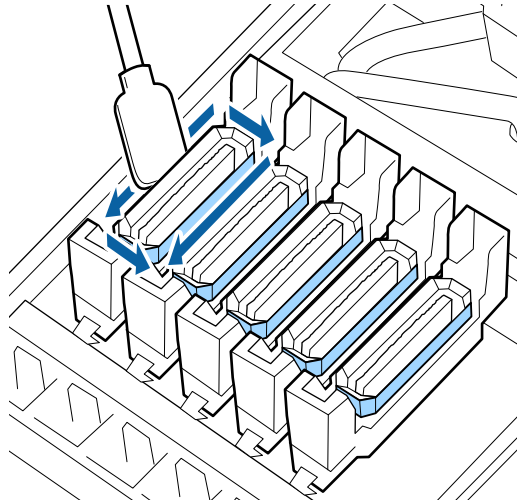

5. Wipe inside the guides as shown here.

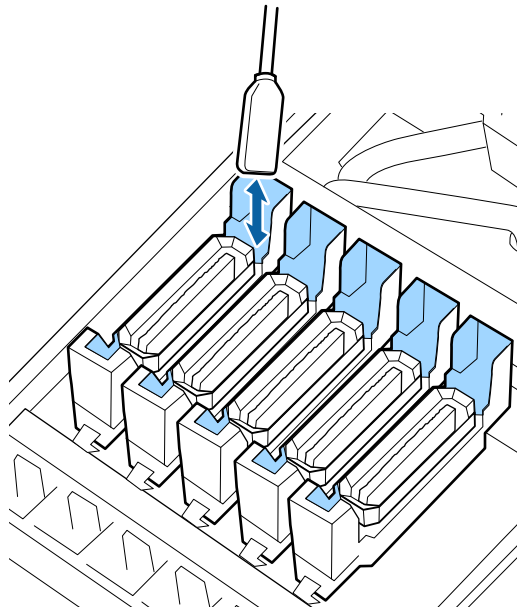

6. If there is any lint or dust in the cap, use the tip of the cleaning stick or the tweezers to remove it.

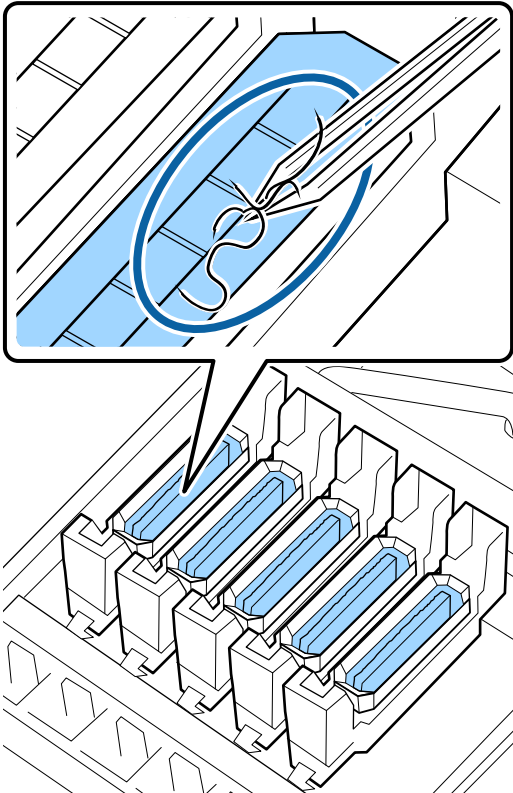

7. If there is any lint or dust attached to the flushing pad, use the tip of the cleaning stick to wipe it off or remove it.

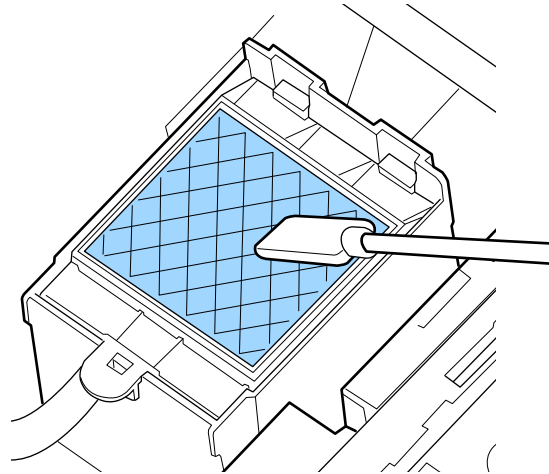

8. When you are finished, close the maintenance cover and press the **OK** button.

Parent topic: [Maintenance](#)

Related references

[Maintenance Supplies](#)

[Maintenance Precautions](#)

Related tasks

[Moving the Print Head for Maintenance](#)

Cleaning the Platen and Media Edge Guides

Carefully follow the steps here to clean the platen and media edge guides to remove ink, paper particles, and lint. We recommend cleaning these parts daily.

Caution: If ink remains on these parts, it could transfer to your printouts. Continued use of your product with ink, paper particles, or lint on these surfaces could damage the print heads or clog the nozzles.

Warning: The after heater may be hot; take care not to burn yourself as you clean your product.

1. Turn off the product, wait for the LCD screen to turn off, and unplug the power cable from the electrical outlet.
2. Wait for one minute before continuing.
3. Open the front cover.
4. Using a soft cloth lightly dampened with water, wipe side to side over the platen to clean it as shown here. Also remove any lint or dust from the cutter groove in the platen.

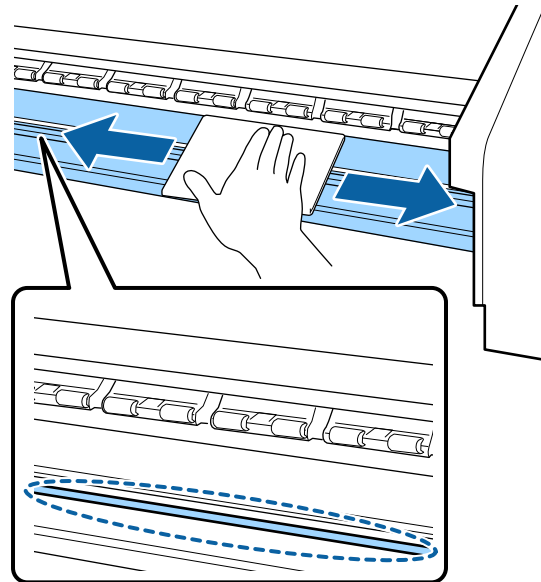

Note: Do not use ink cleaner when cleaning the platen or media edge guides.

5. Using a soft cloth lightly dampened with water, wipe the media edge guides to clean them. If ink or media glue adheres to the media edge guides, remove them and clean both sides as shown here.

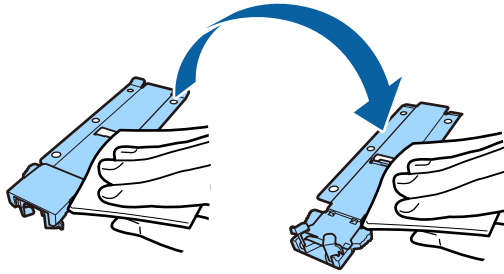

6. Close the front cover, plug in the power cord, and turn the product back on.

Parent topic: [Maintenance](#)

Related tasks

[Replacing the Media Edge Guides](#)

Cleaning the Heat Shield

Clean the heat shield to remove any ink that could affect print quality. You need a Philips-head screwdriver to remove the shield for cleaning.

1. Use the screwdriver to remove the four screws securing the heat shield and remove the heat shield from the ink tank cover.

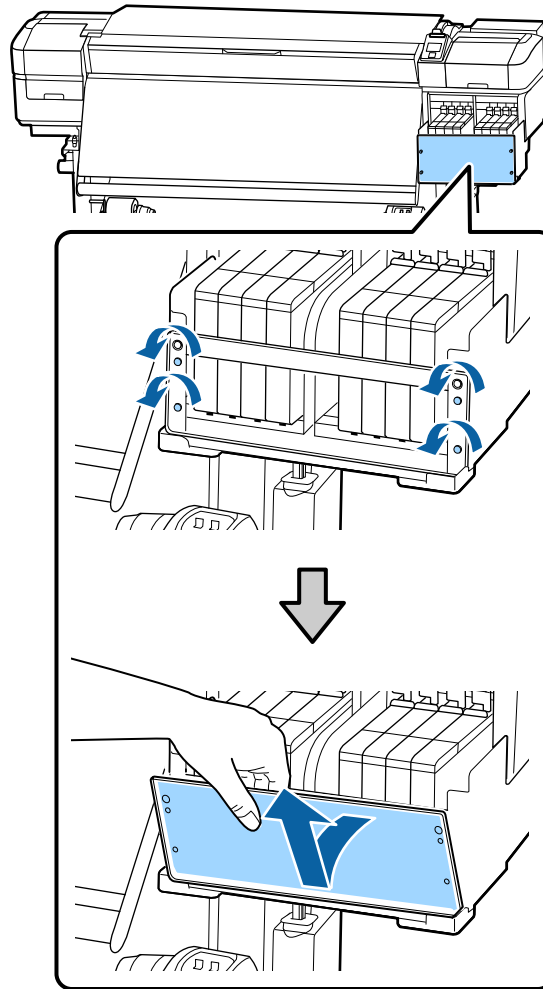

- Using a soft cloth slightly dampened with water, wipe off both sides of the heat shield as necessary.

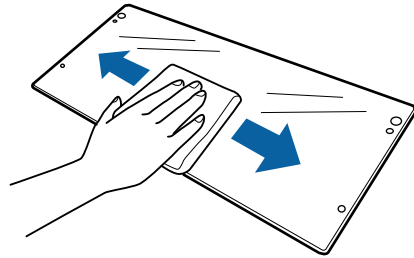

- Align the holes in the heat shield with the holes in the ink tank cover. Then insert and tighten the screws using the screwdriver to secure the cover.

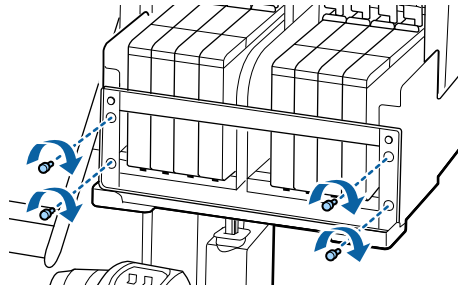

Parent topic: [Maintenance](#)

Replacing the Waste Ink Bottle

When you see one of these messages on the product's LCD screen, you need to replace the waste ink bottle:

- **Prepare empty waste ink bottle**
- **Replace waste ink bottle and press OK**

Wait until the product is not printing or cleaning the print heads before replacing the waste ink bottle.

Caution: Replacing the waste ink bottle during printing or cleaning could cause waste ink to leak. When replacing the waste ink bottle, always wear the gloves included in the maintenance kit. Leave the waste ink in the bottle for disposal and do not transfer it to another container.

1. Raise the stopper on the waste ink bottle.

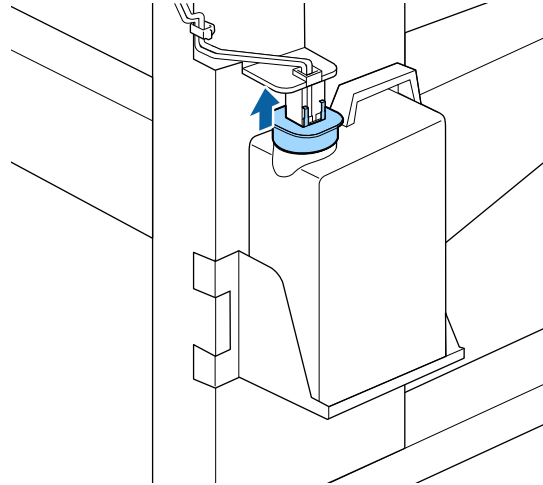

2. Lift up the waste ink bottle and remove it from the holder as shown.

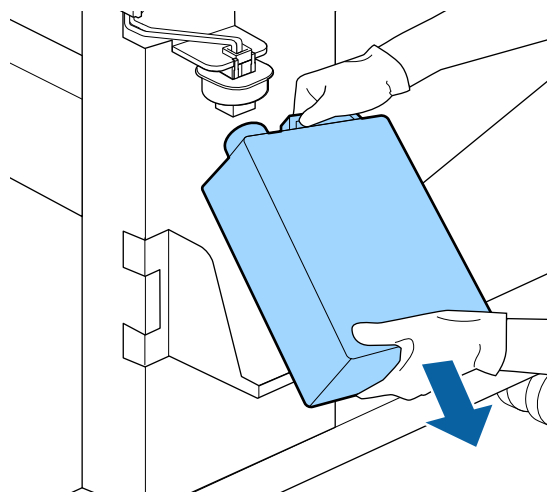
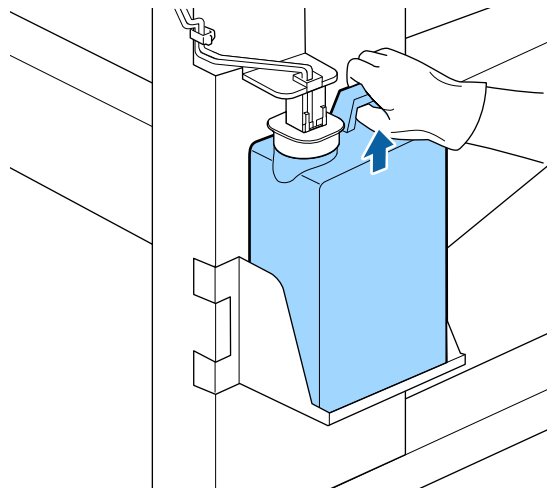

3. Remove the inner seal and cap from the new waste ink bottle and put them on the used waste ink tank bottle.
4. Insert the waste ink tube into the new waste ink bottle and place the bottle in the holder.

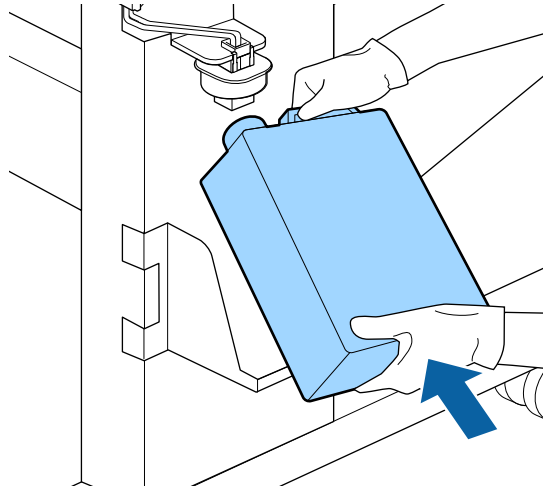

Caution: Be sure the waste ink tube is inserted in the waste ink bottle or waste ink could spill onto your product.

5. Lower the stopper onto the waste ink bottle and make sure it firmly seals to the mouth of the bottle.

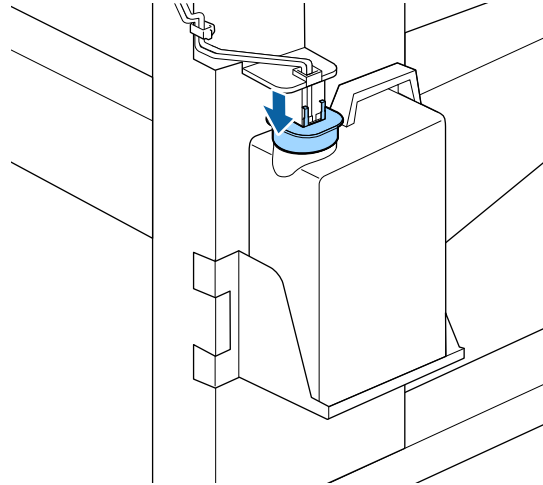

Caution: If the ink splash guard does not firmly seal, waste ink could spill onto your product.

6. Press the **OK** button on the product control panel.
7. Press the **OK** button again to reset the waste ink counter.

Note: If you replaced the waste ink bottle before the replacement message appeared on the control panel, press the  maintenance button and select **Waste Ink Counter** to clear the waste ink counter.

Parent topic: [Maintenance](#)

Related references

[Maintenance Precautions](#)

[Consumables and Replacement Parts](#)

Replacing the Head Cleaning Set

If you notice any of the following, you need to replace the head cleaning set:

- Your printouts are faint or smudged.

- Segments are missing even after cleaning the print head.
 - You see a message on the LCD screen.
1. Before you replace the head cleaning set, move the print heads into maintenance position.
 2. After the print heads move to the left side of the printer, open the right maintenance cover.

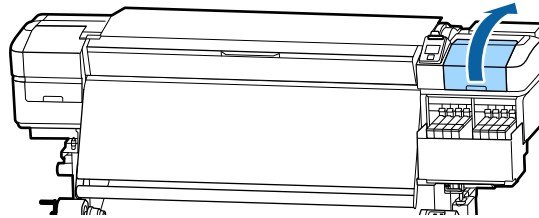

3. Grip the back of the wiper unit and tilt it up slightly.

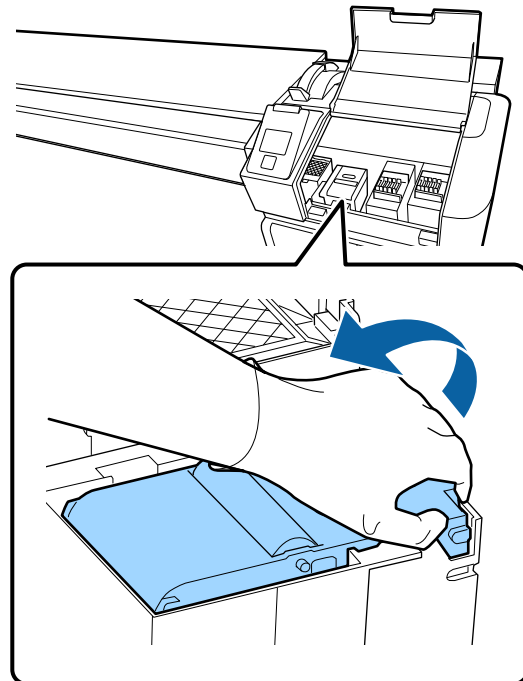

4. Grip the sides of the wiper unit and pull it straight up to remove it.

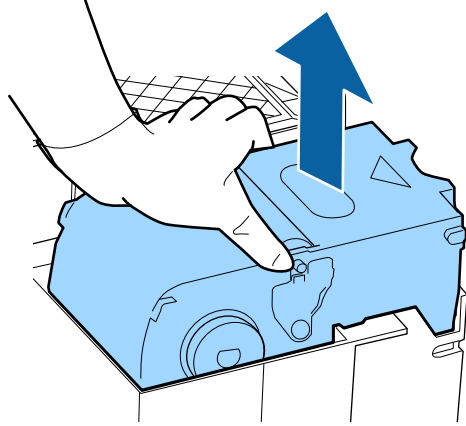

5. Wrap the used wiper unit in the packaging supplied with the new wiper unit to prevent ink leaks.
6. Place the new wiper unit on the attachment point and press it down until it clicks into place.

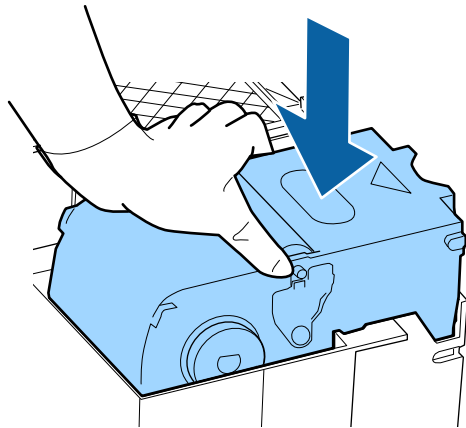

7. Press the **OK** button.

8. Lift up the tab on the flushing pad and remove the pad.

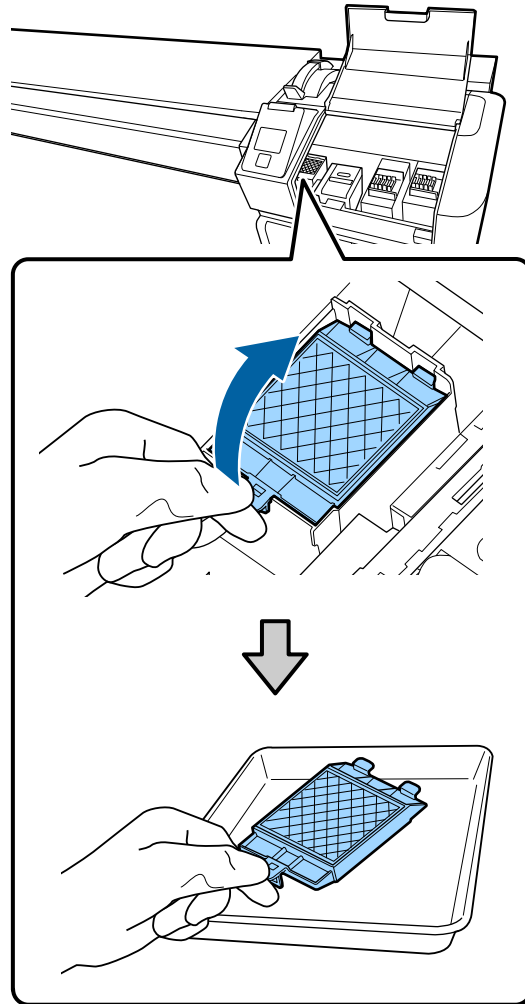

9. Insert the two hooks on the new flushing pad into the slots and press the tab down until it clicks into place.

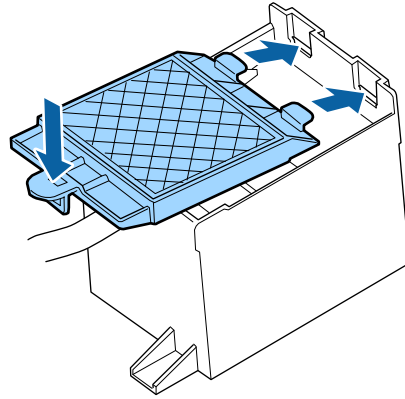

10. Press the **OK** button.
11. Close the maintenance cover and press the **OK** button.
12. Press the up or down arrow buttons to select **Yes** and press the **OK** button to return the print heads to the home position.

Parent topic: [Maintenance](#)

Related references

[Maintenance Precautions](#)

[Consumables and Replacement Parts](#)

Related tasks

[Moving the Print Head for Maintenance](#)

Replacing the Media Edge Guides

If the media edge guides that came with your product become damaged or deformed, you need to replace them.

Caution: Continued use of damaged or deformed media edge guides may damage the print heads.

1. Remove any media loaded in the product and turn off the product. Wait one minute before continuing.

2. Open the left maintenance cover and the front cover.

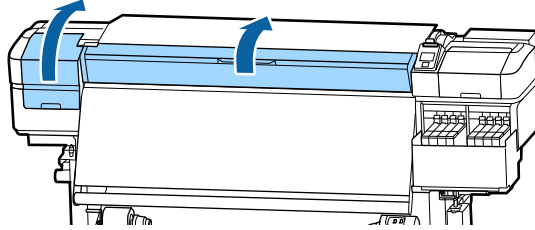

3. Grasp the tabs on the media edge guides and slide them to the left edge of the platen.

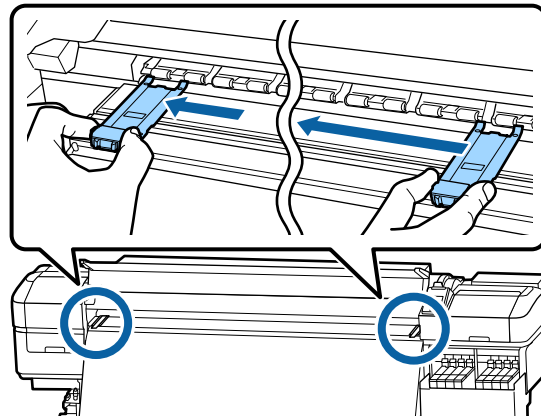

4. Remove the left media edge guide as shown, then remove the right media edge guide in the same manner.

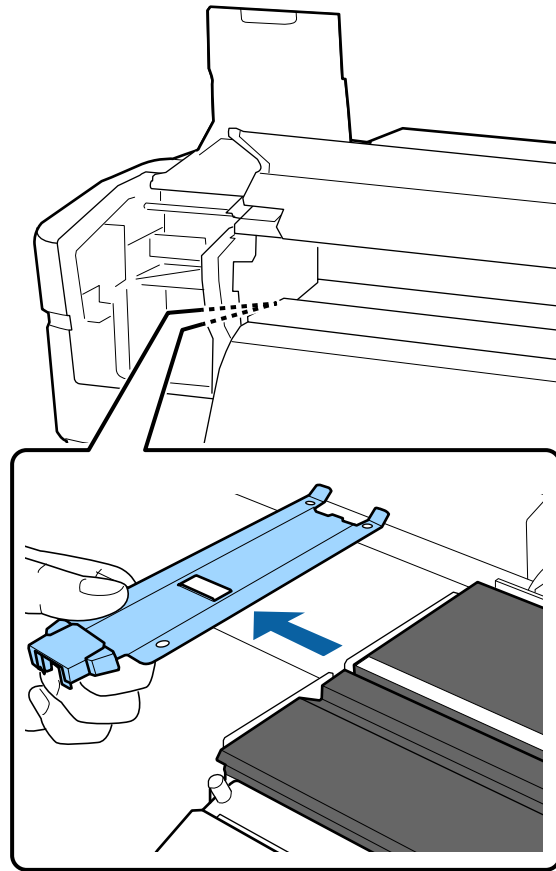

5. Align the white line on a new media edge guide with the edge of the platen.

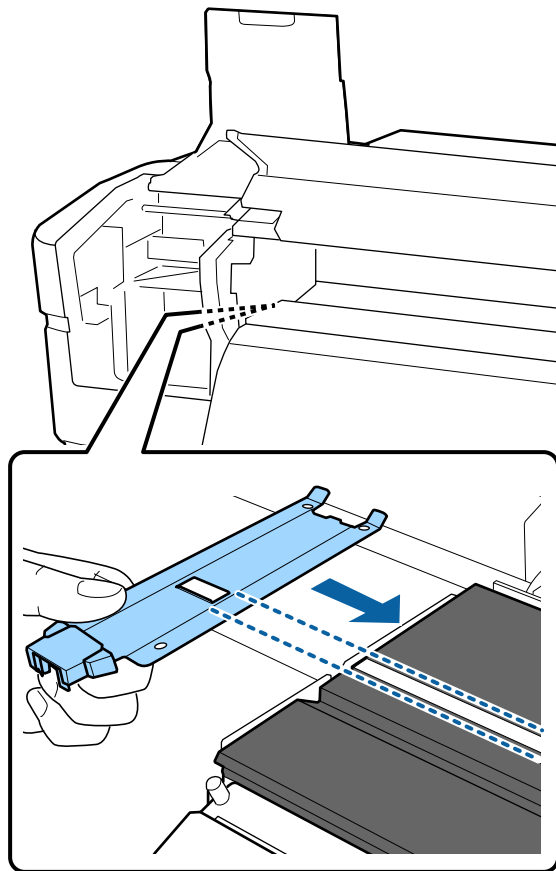

6. While pressing the tip of the media edge guide against the platen, attach the hooks to the front corner of the platen.

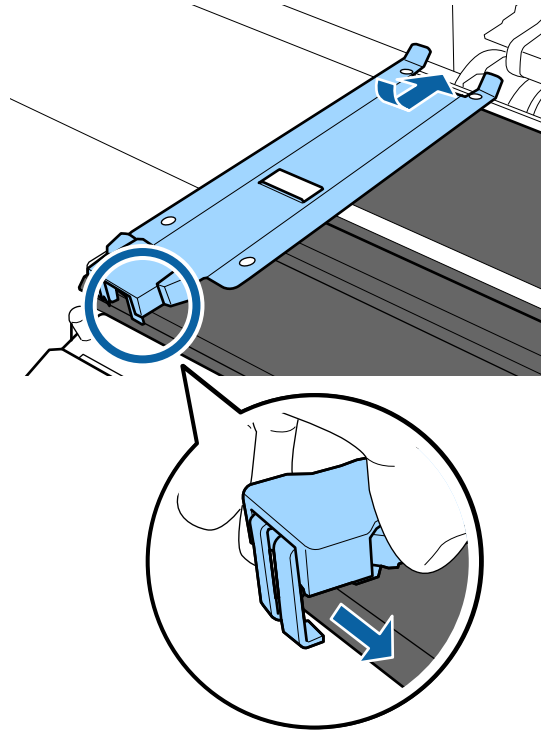

Caution: Do not install the media edge guides on the right edge of the platen or they could drop into the product and cause it to malfunction.

7. Confirm that the three hooked sections of the media edge guide are securely attached as shown, with no gap between the guide and the platen.
 - The hook at the front of the tab (1) should hook onto the corners of the platen.
 - The hook at the rear of the square hole (2) should rest in the groove in front of the white line on the platen.

- The hook at the rear of the tab (3) should hook onto the front corner of the platen.

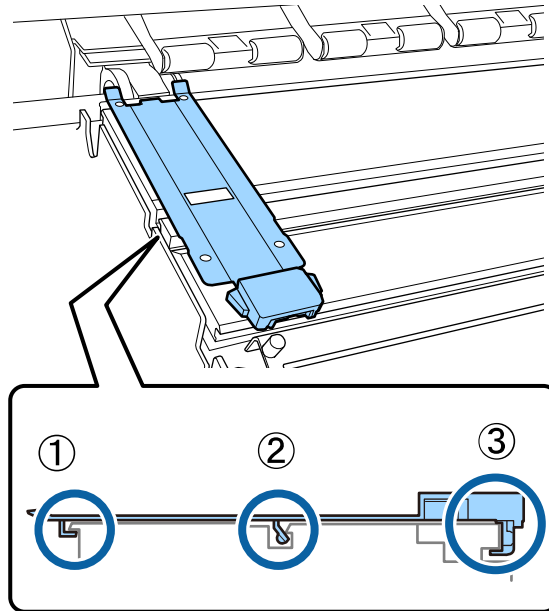

Caution: If the media edge guides are not attached correctly, repeat these steps to reattach them or the print heads may be damaged.

8. Repeat the previous steps to align and attach the other media edge guide, confirming that it is attached correctly.

9. Grasp the tabs on the media edge guides and slide them to the left and right edges of the platen. Release the tabs when they are in position.

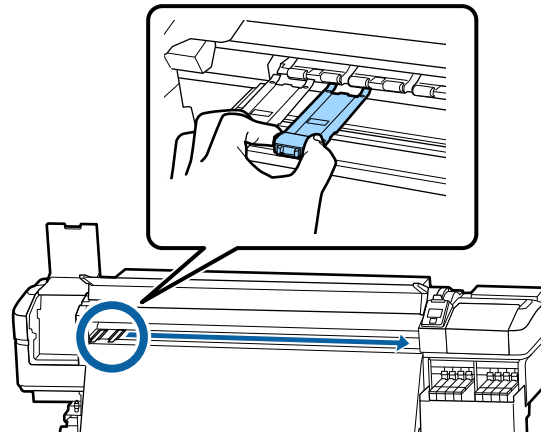

10. Close the left maintenance cover and the front cover.

Parent topic: [Maintenance](#)

Related references

[Maintenance Precautions](#)

[Consumables and Replacement Parts](#)

Related tasks

[Cutting Media](#)

Applying Carriage Rod Grease

When you see the message **Apply secondary carriage rod grease** on the LCD screen, you need to apply grease to carriage rods A and B using the grease and tools that came with your product. Use a new grease pad when applying grease to the carriage rods.

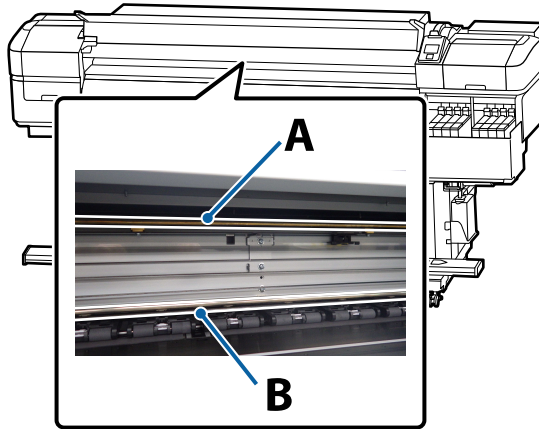

1. To grease carriage rod A, locate the grease tool and pad A that came with your product.

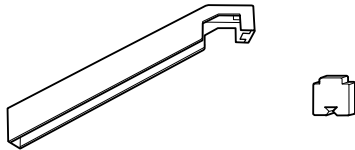

2. Press the  maintenance button.
You see the **Maintenance** menu.
3. Press down arrow button to select **Other Maintenance** and press the **OK** button.
4. Press the **OK** button to select **Grease Carriage Rod**.
You see the message **Grease kit is needed. Continue?**
5. Press the **OK** button to select **Yes**.
6. Open the front cover.

7. Firmly insert the tab on pad A into the slot on the grease tool and rotate the pad onto the tool as shown here.

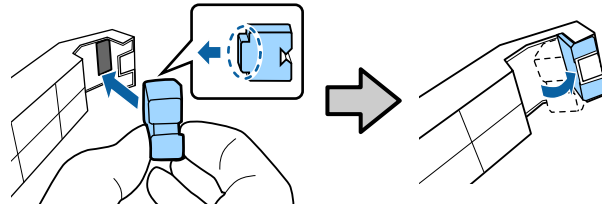

8. Hold the grease tool against the back of carriage rod A and smoothly slide it from right to left across the carriage rod four times.

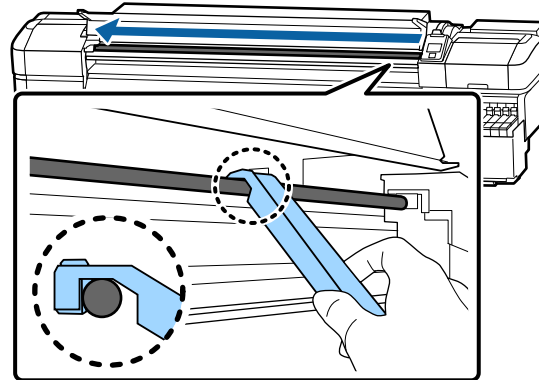

Caution: Do not slide the tool back and forth; dust may enter the print head and damage can occur.

9. Remove the stained pad from the grease tool.
10. Attach a fresh pad A to the grease tool.
11. Use one of the cleaning sticks to stir the grease in the container approximately 10 times. Then wipe the tip of the cleaning stick on the edge of the container to remove the excess grease.

Note: Be sure to remove the excess grease from the cleaning stick or it may fall off the stick and onto the platen or your media.

12. Fully submerge the tip of the cleaning stick into the grease, rotate the stick two or three times, and remove it from the grease. Then apply the grease to pad A on the end of the grease tool.

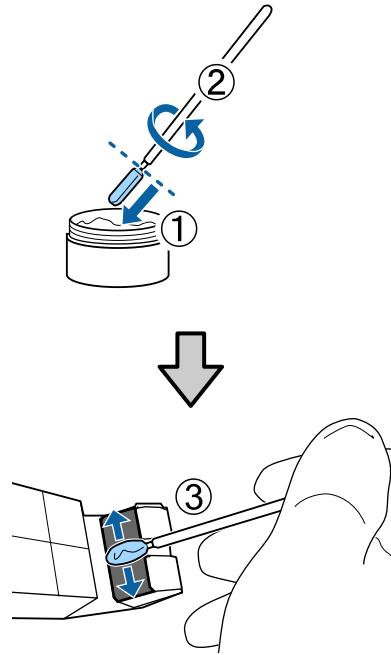

13. Hold the grease tool against the back of carriage rod A and smoothly slide it back and forth twice across the carriage rod to grease the rod, as shown in step 8.
14. To grease carriage rod B, locate pad B that came with your product.



15. Hold pad B against the front of carriage rod B and smoothly slide it from right to left across the carriage rod four times.

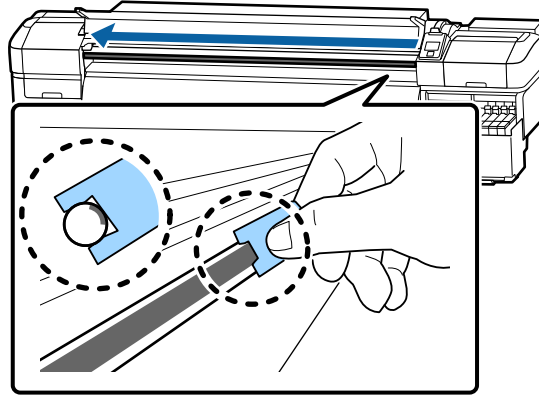

Caution: Do not slide the tool back and forth; dust may enter the print head and damage can occur.

16. Fully submerge the tip of a cleaning stick into the grease, rotate the stick two or three times, and remove it from the grease. Then apply the grease to pad B.

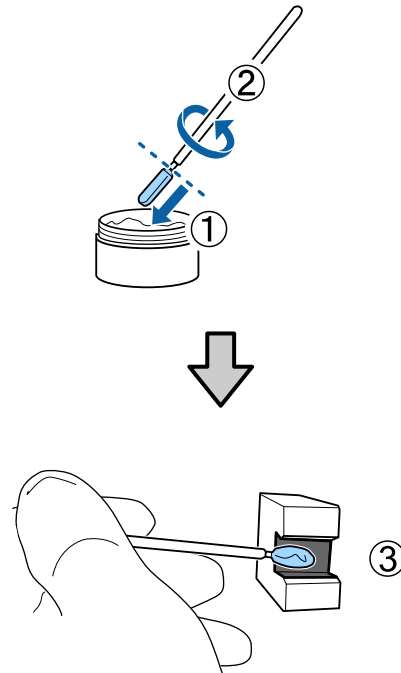

17. Hold pad B against the front of carriage rod B and smoothly slide it back and forth twice across the carriage rod to grease the rod, as shown in step 15.
18. Close the front cover and press the **OK** button.
The carriage moves back and forth.
19. Remove the used pad A from the grease tool, and dispose of pad A and pad B properly. Close the grease container and store it out of direct sunlight and at room temperature along with the grease tool and other supplies.

Parent topic: [Maintenance](#)

Related references

[Maintenance Precautions](#)

[Consumables and Replacement Parts](#)

Maintenance Supplies
Maintenance Menu Settings

Moving or Transporting the Product

When moving the product, see these sections to prepare and move the product, and set it back up after moving it.

If you need to transport the product a long distance, contact Epson support.

[Preparing to Move the Product](#)

[Setting Up the Product After Moving](#)

Preparing to Move the Product

Do the following before moving the product:

1. Remove any loaded media from the media feeding unit and auto take-up reel.
2. Turn off the product.
3. Remove the waste ink bottle.
4. Remove all cables.
5. Make sure the adjusters next to the casters are raised. Using a wrench, loosen the nut at the top of each adjuster and turn the nut on the bottom counterclockwise until the adjuster raises off the floor.

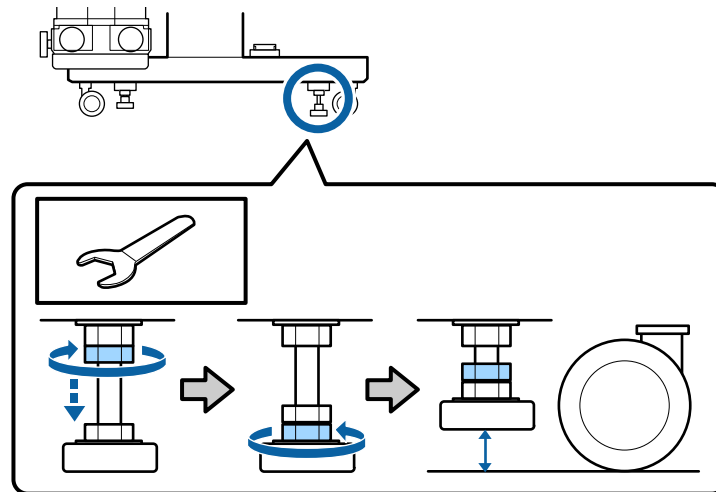

6. Unlock the two casters.

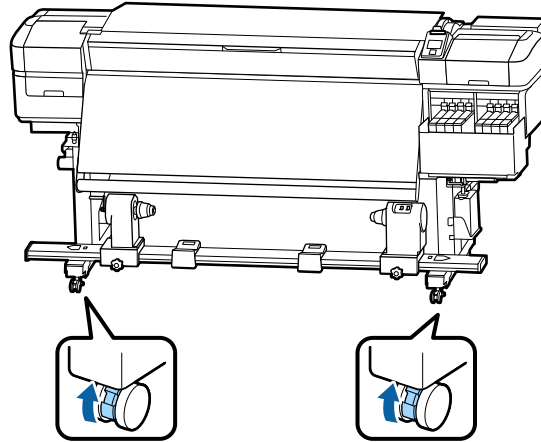

Caution: Roll the product on the casters for only a short distance over a level floor. Do not transport the product using the casters.

Parent topic: [Moving or Transporting the Product](#)

Related tasks

[Cutting Media](#)

[Replacing the Waste Ink Bottle](#)

Setting Up the Product After Moving

Follow these steps to set up the product after moving it.

1. Verify that the location is suitable for installation.
2. Perform parallel adjustment for the media feeding unit and auto take-up reel as necessary.
3. Install the waste ink bottle.
4. Connect the power cable to an electrical outlet and turn on the printer.
5. Load media in the product.
6. Adjust the media feed from the **Customize Settings** menu.

Parent topic: [Moving or Transporting the Product](#)

Related references

[Media Setup Menu Settings](#)

Related tasks

[Replacing the Waste Ink Bottle](#)

[Loading Media](#)

[Checking for Clogged Print Head Nozzles](#)

[Cleaning the Print Head](#)

[Adjusting the Auto Take-up Reel \(Parallel Adjustment\)](#)

Solving Problems

Check these sections for solutions to problems you may have using your product.

[Product Status Messages](#)

[Solving Printer Problems](#)

[Solving Printing Problems](#)

[Solving Media Skew Problems](#)

[Solving Print Quality Problems](#)

[Uninstall Your Product Software](#)



[Where to Get Help](#)

Product Status Messages

You can often diagnose problems with your product by checking the messages on the LCD screen.

LCD screen message	Solution
Prepare empty waste ink bottle.	The waste ink bottle is almost full. Make sure you have a replacement waste ink bottle handy.

LCD screen message	Solution
Chip unit error Chip unit not recognized. Replace chip unit.	Remove and reinstall the chip unit. If the error recurs, replace the chip unit with a new one. Make sure the chip unit is installed properly on the correct ink tank color. Condensation may have formed inside the ink tank. Make sure the ink is at room temperature for at least four hours.
Chip unit error Cannot be recognized. Remove or replace chip unit.	If you still have problems, contact Epson for support.
Chip unit error Chip unit not recognized. Did you check the names of the supported products on the ink pack before adding the ink into the printer?	
Chip unit error Replace with chip unit that supports this printer.	
Please check ink level.	Check the remaining ink in the ink tank using the scale on the ink pack and, if necessary, refill the ink and replace the chip unit.
Printing will pause if chip unit is not replaced.	Make sure you have a replacement ink pack in the correct color handy.
Warming Up... OK Force to start printing	The after heater is still warming to the specified temperature. Press the OK button to start printing without waiting for the after heater to warm up.
Clogged nozzles detected. Cleaning recommended.	Press the II  pause/cancel button and select Job Cancel to cancel printing. Perform a head cleaning based on the printout results.

LCD screen message	Solution
F/W Install Error Firmware update failed. Restart the printer.	Turn off the product, wait a few minutes, and turn it on again. Then reinstall the firmware again. If this message persists, contact Epson for support.
Print head is nearing end of service life.	Contact Epson for support.
Auto Take-up Reel Unit stopped.	Press the II  pause/cancel button and select Job Cancel to cancel printing. Then set the Auto switch on the auto take-up reel to the off position, set it back to the original position, and reattach the media to the auto take-up reel.
Internal Temp. High Lower room temperature.	Lower the room temperature to the range specified.
Internal Temp. High Turn printer off. Wait for printer to cool and then turn on again.	Turn off the product. Lower the room temperature to the range specified. If the message still appears when the power is turned back on, the room temperature is still too hot.
Media Size Error Load correct size media.	Raise the media loading lever and remove the currently loaded media. Be sure the media is at least 11.8 inches (300 mm) wide. If this message appears even when the media is a supported width, turn off the Media Size Check setting and try printing again.
Media Sensor Error Loaded media or sensor has a problem. Refer to the manual for error details.	Press the II  pause/cancel button and select Job Cancel to cancel printing. Make sure media has an even surface and does not bleed through easily. Set the Platen Gap setting to 2.5 . Make sure the product is not exposed to direct sunlight.
Media Sensor Error Refer to manual for details of error. Adjust manually?	If the error persists, perform a manual feed adjustment in the Media Setup menu.

LCD screen message	Solution
Roll Type Error Release and then reset the media loading lever, then match Roll Type setting to actual media.	Make sure the Roll Type setting is correct for the loaded media. Follow the on-screen instructions to clear the error.
Refer to manual and perform regular cleaning.	You have not performed regular cleaning for one month. If you do not clean the print head, nozzle clogs or print head damage may occur.
Maintenance Request Replace Part Now/Replace Part Soon XXXXXXXXXXXX	The indicated product part is nearing or at the end of its service life. Contact Epson for support and provide them with the service code shown on the LCD screen. You must replace the part before printing again. If you continue to print, a call for service occurs.
Call For Service XXX Error XXX Power off and then on. If this doesn't work, note the code and call for service.	A call for service occurs when: <ul style="list-style-type: none"> • The power cable is not connected securely • An error occurs that cannot be cleared When a call for service has occurred, the printer automatically stops printing. Turn off the printer, disconnect the power cable from both the outlet and the printer, and then reconnect them. Turn the printer on and off several times. If the same call for service is displayed on the LCD screen, contact Epson for support and provide them with the service code shown on the LCD screen.

Parent topic: [Solving Problems](#)

Related references

[Where to Get Help](#)

[Environmental Specifications](#)

[Media Setup Menu Settings](#)

[Printer Setup Menu Settings](#)

Related tasks

[Replacing the Waste Ink Bottle](#)

[Replacing the Chip Unit and Refilling Ink](#)

[Cleaning the Print Head](#)

[Checking for Clogged Print Head Nozzles](#)

Solving Printer Problems

Check these sections if you have problems operating your product.

[Printer Does Not Turn On](#)

[LCD Screen Shuts Off](#)

[After Heater Shuts Off](#)

[Forgot the Administrator Password](#)

[Red Light Shines Inside the Printer](#)

Parent topic: [Solving Problems](#)

Printer Does Not Turn On

If the printer does not turn on, try these solutions:

- Make sure the power cable is securely connected.
- Make sure the power outlet works by connecting the power cable for another electronic device.

Parent topic: [Solving Printer Problems](#)

LCD Screen Shuts Off

If the LCD screen shuts off intermittently, the printer may be in sleep mode. Try these solutions:

- Press any of the buttons on the control panel to exit sleep mode.
- You can adjust the delay time before the product enters sleep mode in the Printer Setup menu.

Parent topic: [Solving Printer Problems](#)

Related references

[Printer Setup Menu Settings](#)

After Heater Shuts Off

If the after heater turns off automatically, try these solutions:

- The after heater shuts off when the product is in sleep mode. Press any of the buttons on the control panel to exit sleep mode.
- You can adjust the delay time before the product enters sleep mode in the Printer Setup menu.

Parent topic: [Solving Printer Problems](#)

Related references

[Printer Setup Menu Settings](#)

Forgot the Administrator Password

If you forgot the administrator password you created during network setup, contact Epson for support.

Parent topic: [Solving Printer Problems](#)

Related references

[Where to Get Help](#)

Red Light Shines Inside the Printer

The red light always shines inside the printer. This is normal.

Parent topic: [Solving Printer Problems](#)

Solving Printing Problems

Check these sections if you have problems printing with your product.

[Nothing Prints](#)

[Cannot Print Over a Network](#)

[Print Head Moves But Nothing Prints](#)

[Media Is Creased](#)

[Printing Continues After Media Roll Empties](#)

[Removing Jammed Media](#)

[Media Does Not Feed Correctly](#)

Parent topic: [Solving Problems](#)

Nothing Prints

If you have sent a print job and nothing prints, try these solutions:

- Make sure your printer is turned on .
- Make sure any interface cables are connected securely at both ends. If you have a spare cable, try connecting with the spare cable.
- Check the model and specifications of the interface cable to see if the cable is appropriate for your computer and printer.

- If you connected your printer to a USB hub, make sure it is a first-tier hub. If it still does not print, connect your printer directly to your computer instead of the hub.
- Make sure the USB hub is recognized correctly on the computer. Disconnect all USB hubs from the computer and connect the printer directly to the computer's USB port.
- Make sure the USB cable length does not exceed 10 feet (3 m).

Parent topic: [Solving Printing Problems](#)

Related references

[Interface Specifications](#)

Cannot Print Over a Network

If you cannot print over a network, try these solutions:

- Make sure that your printer is turned on.
- If you are using TCP/IP, make sure the printer's IP address is set correctly for your network. If your network does not assign IP addresses using DHCP, set the IP address manually.
- Check your wired LAN router or access point to see if the LED for the port to which your printer is connected is on or flashing. If the link LED is off, try the following:
 - Make sure the Ethernet cable is securely connected to your printer and to your router, access point, switch, or hub.
 - Try connecting your printer to a different port or a different router, access point, switch, or hub.
 - Try connecting with a different Ethernet cable.
 - Try printing to your printer from another computer on the network.

Parent topic: [Solving Printing Problems](#)

Related references

[Other Settings Menu Settings](#)

Print Head Moves But Nothing Prints

If the print head is moving and nothing prints, print a nozzle check pattern. If the pattern does not print correctly, clean the print head. (If the printer has not been used for a long time the nozzles may be clogged.)

Parent topic: [Solving Printing Problems](#)

Related tasks

[Cleaning the Print Head](#)

Checking for Clogged Print Head Nozzles

Media Is Creased

If media loaded in your printer is creased, try these solutions:

- Check that the **Feeding Tension** and **Feed Speed Limiter** settings on the product control panel are correct for the currently loaded media.
- If you printed thin media or media lengthened by water absorption at a high density take-up setting, creases that look like this may appear in the media in the after heater:

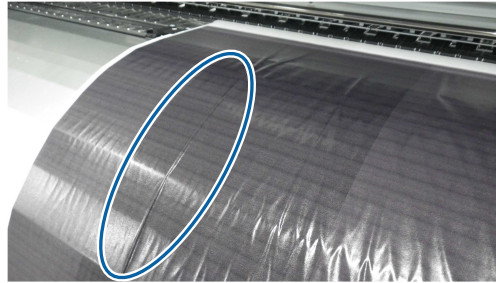

Set the **Take-up Tension** setting to **Manual** and decrease the tension values, or print on thicker media.

- If you printed thin media or media lengthened by water absorption, vertical creases that look like this may occur between the pressure rollers:



Do the following to reduce creasing:

- Set the **Feeding Tension** setting to **Manual** and increase the tension values.
- Set the **Take-up Tension** setting to **Manual** and decrease the tension values.
- Attach a spacer in the slot of the media loading lever.

Parent topic: [Solving Printing Problems](#)

Related references

[Media Setup Menu Settings](#)

Printing Continues After Media Roll Empties

If printing does not stop when the media roll ends, make sure the **Media End Check** setting is set to **On**. For best results, leave this setting turned on.

Parent topic: [Solving Printing Problems](#)

Related references

[Printer Setup Menu Settings](#)

Removing Jammed Media

If media jams in the printer, check the following:

- Make sure the media is not curled, creased, or folded on the leading edge. Do not use media in poor condition.
- Check the media specifications to make sure you can use the media with your printer and your RIP software. Check the RIP software manufacturers media guidelines.
- Set the **Media Suction** setting to a lower value on the product control panel.

Follow the steps here if media becomes jammed in the product.

1. Open the front cover.

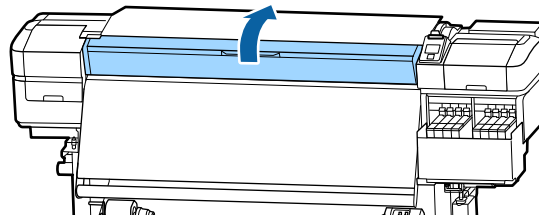

2. Turn off the product.

Note: If you see a message on the product control panel and the product will not turn off, unplug the power cable.

3. Grasp the tabs on the media edge guides and slide them to the left and right sides.

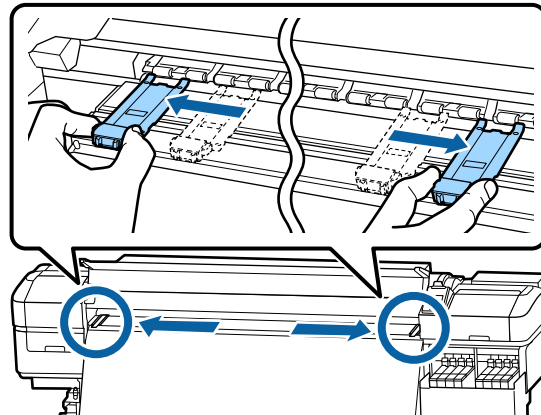

Caution: If the media edge guides are deformed or damaged, do not continue to use them or you could damage the pressure rollers or print heads. Replace the media edge guides before continuing with these steps to remove jammed media.

4. If the print head is over the media, move it away from the jam area by hand.

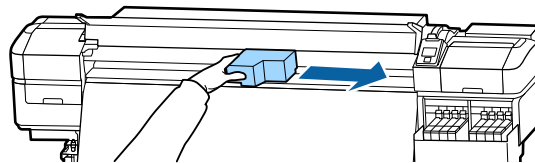

5. Raise the media loading lever.

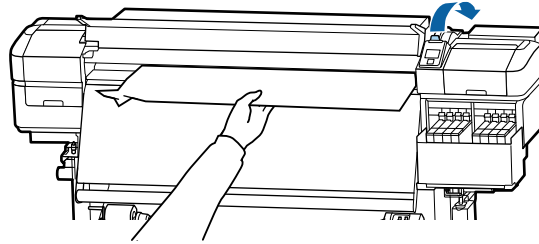

6. Pull the media to the cutter groove and cut off the torn or creased media from the roll.

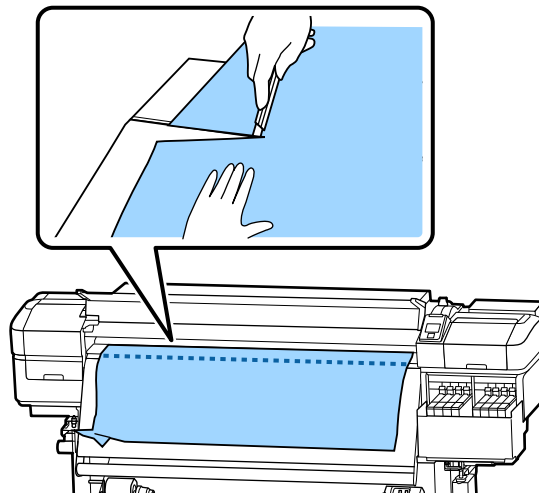

7. Manually rewind the media.
8. Remove any media that remains inside the product.
9. Turn the product back on, load media, run a nozzle check and, if necessary, clean the print heads.

Caution: Do not leave the product turned off with the print heads in an uncapped position for an extended period. The print heads may dry out and the product may not print properly.

Parent topic: [Solving Printing Problems](#)

Related references

[Media Setup Menu Settings](#)

Related tasks

[Cutting Media](#)

[Cleaning the Print Head](#)

[Checking for Clogged Print Head Nozzles](#)

Media Does Not Feed Correctly

If media does not feed straight or roll up on the auto take-up reel correctly, try these solutions:

- Make sure your media is at least 36 inches (91.4 cm) wide for best results.
- If your media is attached to the auto take-up reel with the printable side out, try attaching with the printable side in instead.
- If your media is thick, set the RIP software settings to use 3 passes or higher for best results.
- Perform the parallel adjustment procedures to correct the feed misalignment, especially after moving the printer.

Parent topic: [Solving Printing Problems](#)

Related references

[Media Specifications](#)

Related tasks

[Adjusting the Auto Take-up Reel \(Parallel Adjustment\)](#)

[Loading Media](#)

Solving Media Skew Problems

If media skew is detected by your product, perform the parallel adjustment procedure to ensure that the media is fed straight into the product and onto the auto take-up reel.

Note: Also perform the parallel adjustment procedure after you have moved the printer.

In addition to parallel adjustment, do the following to avoid media skew problems:

- Set the auto take-up reel to roll the media with the printable side in.
- Use media at least 36 inches (91.4 cm) wide.
- With thick media, set the software RIP to 3 passes or higher.

Parallel Adjustment Tools

Adjusting the Auto Take-up Reel (Parallel Adjustment)

Parent topic: [Solving Problems](#)

Parallel Adjustment Tools

Use these tools to perform the parallel adjustment procedure.

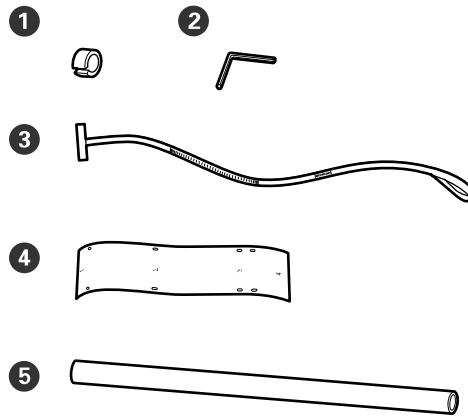

- 1 Counterweights (2)
- 2 Hexagon wrench
- 3 Adjustment tool
- 4 Adjustment guides (2)
- 5 Roll core

Parent topic: [Solving Media Skew Problems](#)

Adjusting the Auto Take-up Reel (Parallel Adjustment)

Two people are required for parallel adjustment: one in front of the printer and one in back.

1. Turn off the product.

2. Loosen both roll core holder locking screws and move the roll core holders inward.

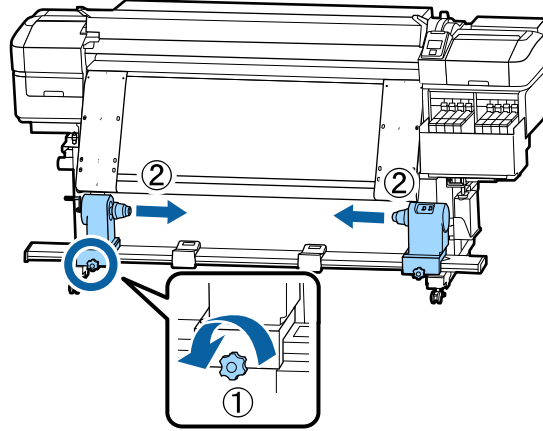

3. Remove the screws and turn the covers shown here to open them.

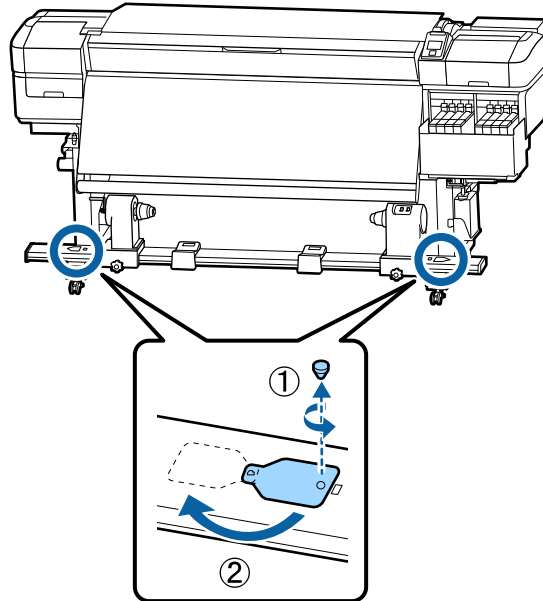

4. Open the front cover and raise the media loading lever.

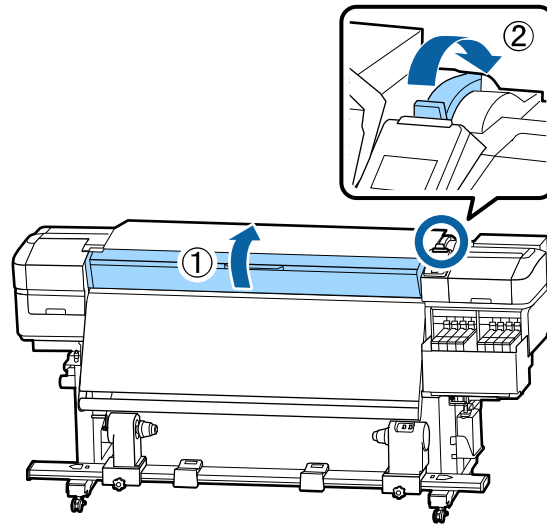

5. Remove the protective film from the back of one adjustment guide.

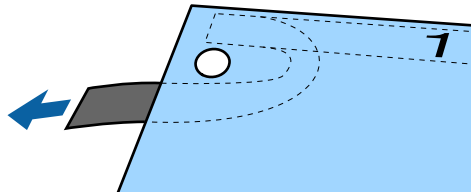

6. Align Hole 1 of the adjustment guide with the screw on the left edge at the top of the after heater and adhere the adjustment guide to the after heater.

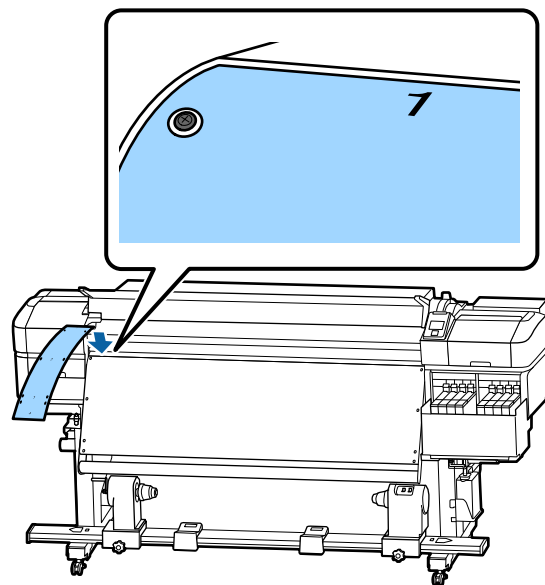

- Align Hole 2, Hole 3, and Hole 4 with the screws on the left edge of the after heater and adhere them.

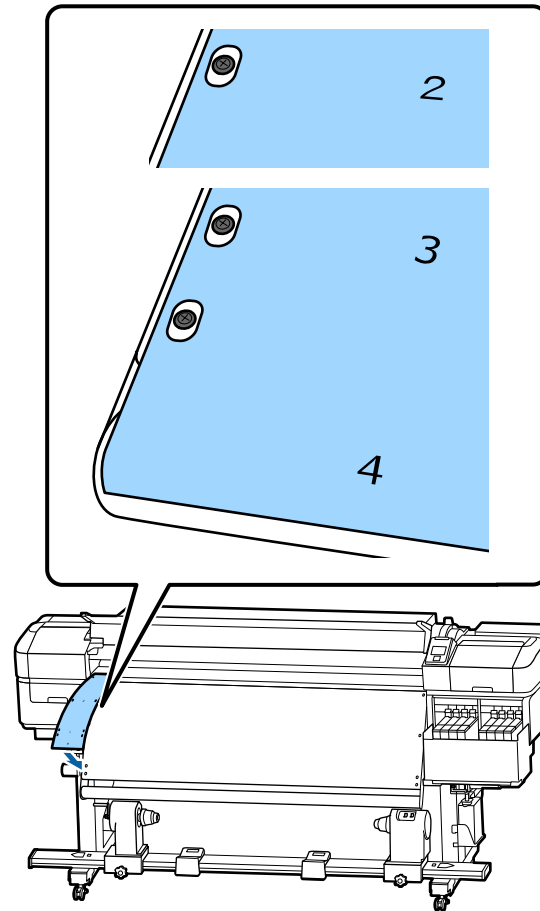

- Repeat steps 5 through 7 to attach the other adjustment guide to the right side of the after heater.

9. Move the left roll core holder outward.

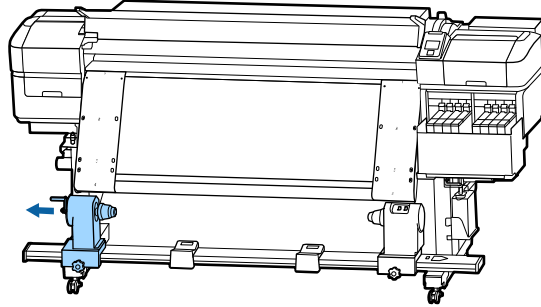

Note: If the left roll core handle shaft is pushed in, rotate the handle as shown until it stops.

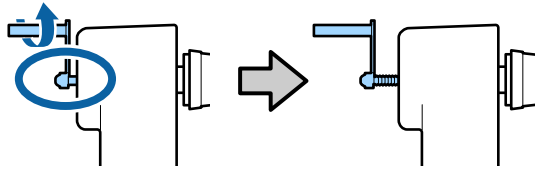

10. Align the right roll core holder with the dotted line as shown and tighten the right roll core locking screw.

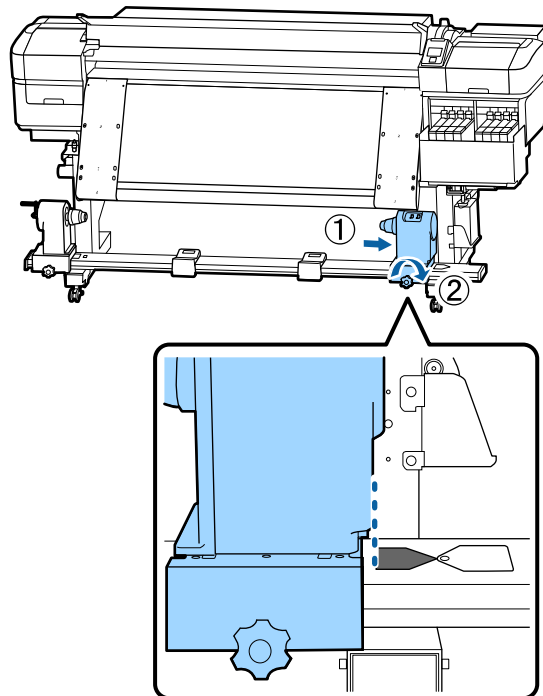

11. Pass the loop on the end of the adjustment tool through the auto take-up reel roll core.

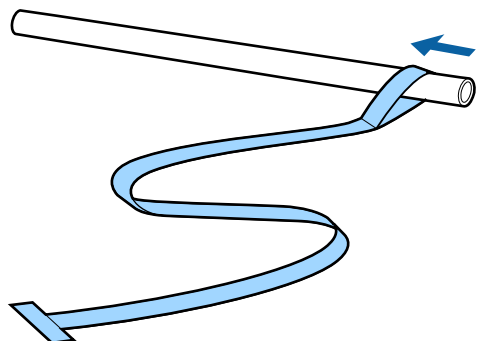

12. Insert the roll core onto the right roll core holder.

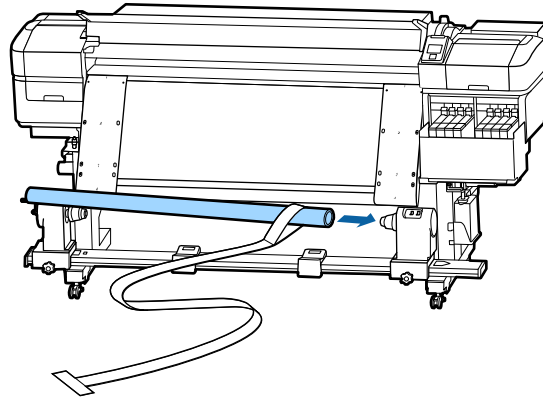

13. Insert the left roll core holder and tighten the roll core holder locking screw.

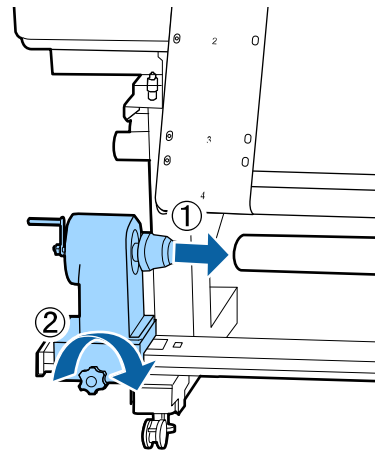

14. Rotate the left roll core handle until part A is fully inserted as shown.

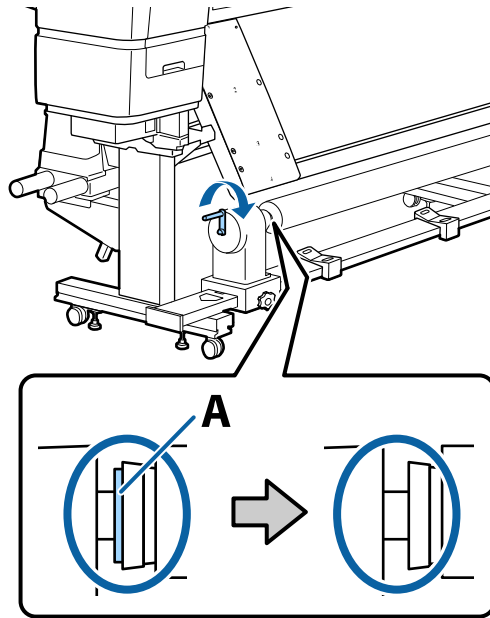

15. Move the adjustment tool to the left side of the after heater. Insert the leading edge of the adjustment tool through the paper path between the media guide bar and the after heater.

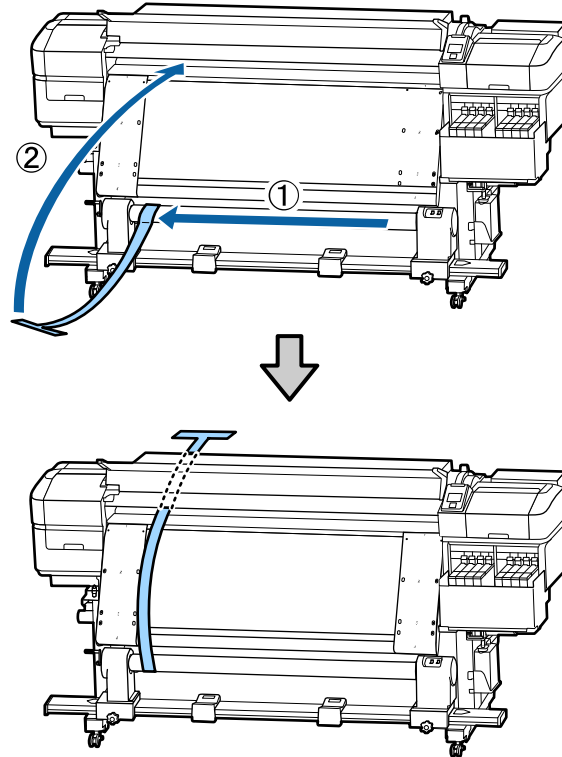

16. Align the adjustment tool and adjustment guide on the left side of the after heater and line them up at the front of the product.

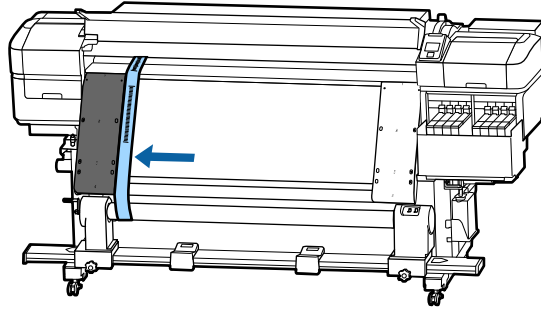

17. Attach a counterweight to the end of the adjustment tool at the back of the product and let it hang as shown. Let the counterweight come to a complete standstill.

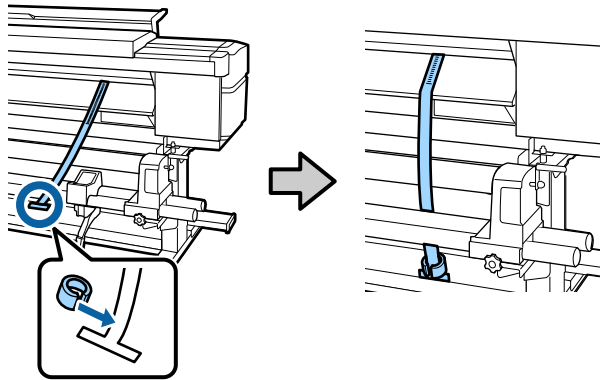

18. Note the value of the scale where the adjustment tool overlaps the front edge of the white line on the platen.

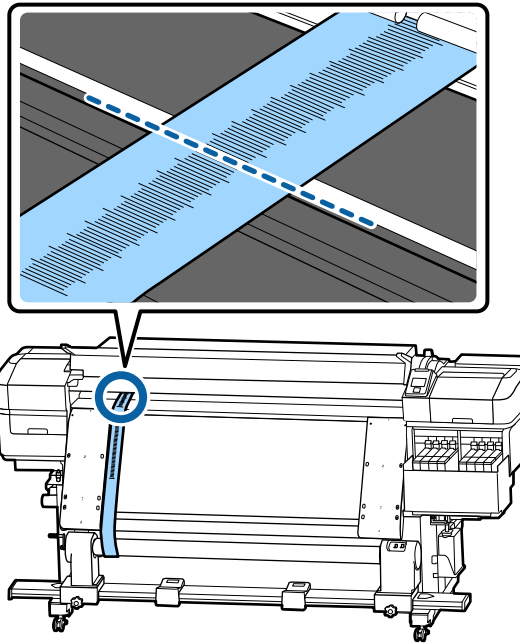

19. Lift up the adjustment tool and slide it to the right side of the after heater. Align the adjustment tool and adjustment guide and line them up at the front of the product. Let the counterweight attached to

the adjustment tool come to a complete standstill. Note the value of the scale where the adjustment tool overlaps the front edge of the white line on the platen.

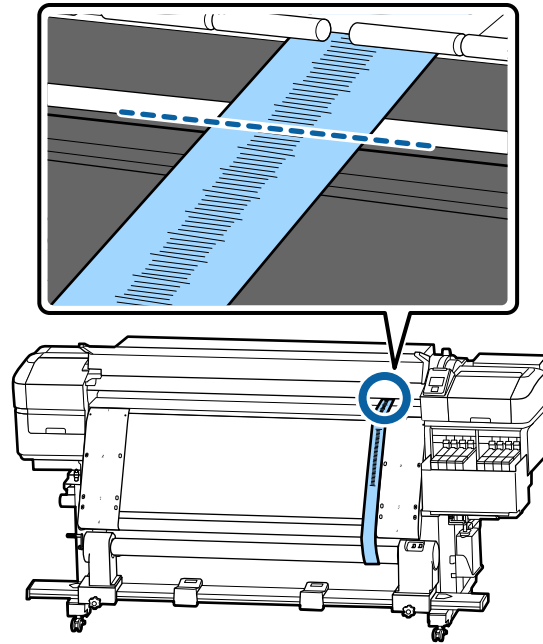

20. Do one of the following:

- If the difference between the values of both sides is more than 0.02 inch (0.5 mm), go to the next step.
- If the difference is under 0.02 inch (0.5 mm), go to step 25.

21. Using the hexagon wrench, loosen all of the metal fixing screws as shown.

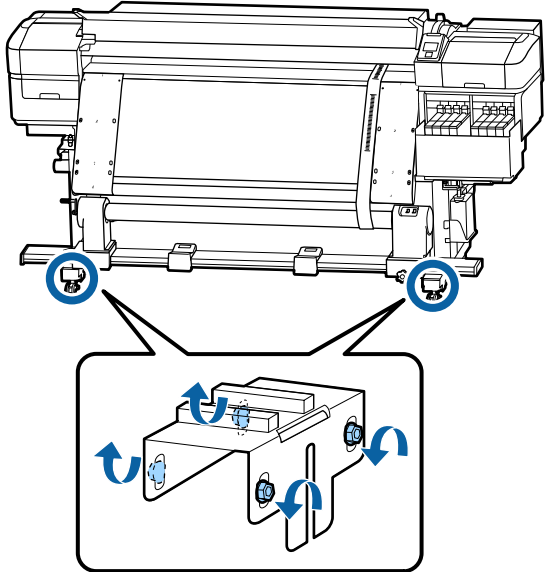

22. Loosen the adjustment screws as shown.

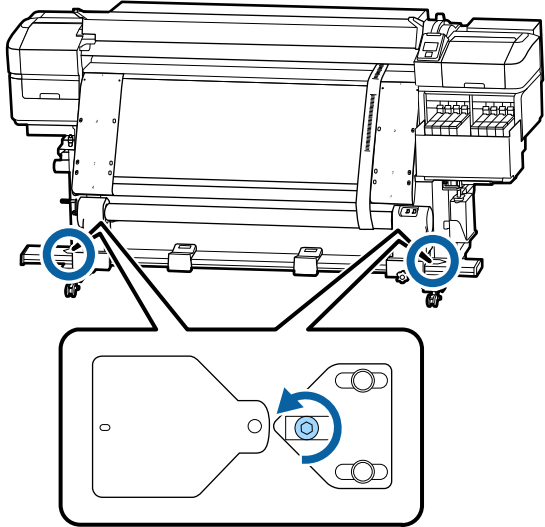

23. Turn the adjustment screw clockwise for each side that has a value more than 0.02 inch (0.5 mm) until the value on the scale is less than 0.02 inch (0.5 mm). Make sure the values are equal on both sides.

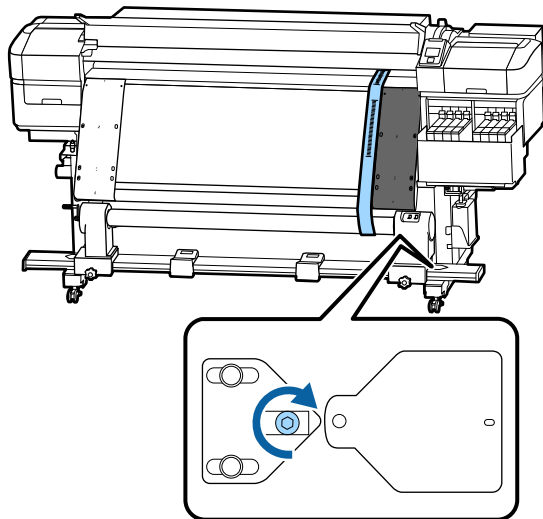

24. Securely tighten all screws as shown.

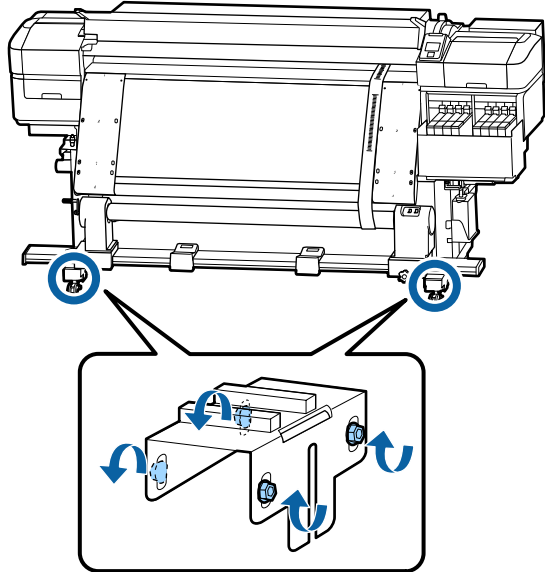

25. At the back of the product, remove the counterweight.

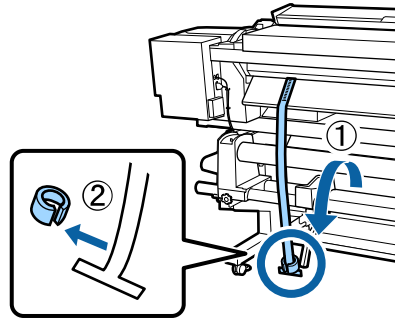

26. At the front of the product, remove the adjustment tool.

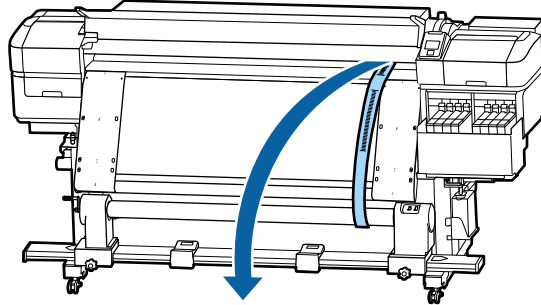

27. Loosen the right roll core holder locking screw and slide the roll core holder to the right.

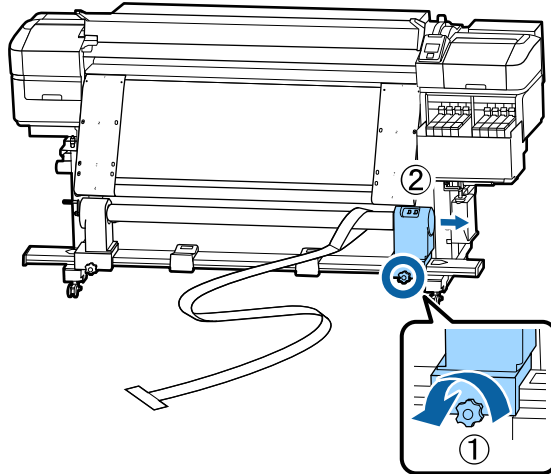

28. Remove the roll core.

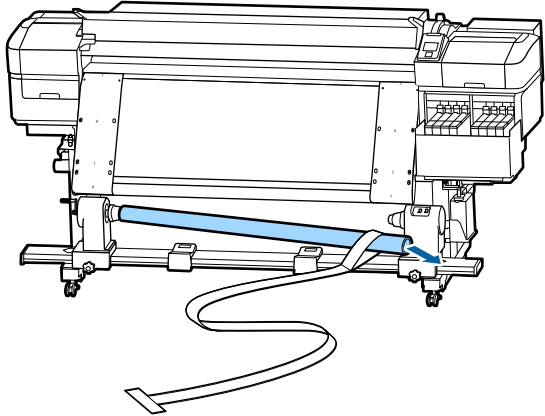

29. Remove the adjustment tool from the roll core.

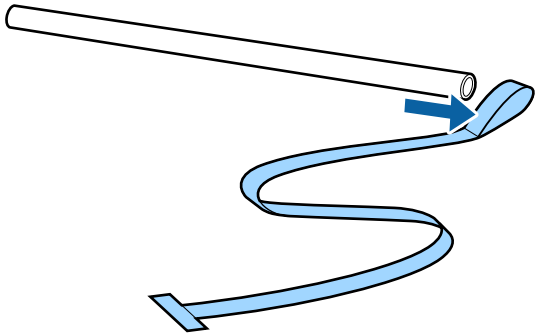

30. Remove both adjustment guides from the product.

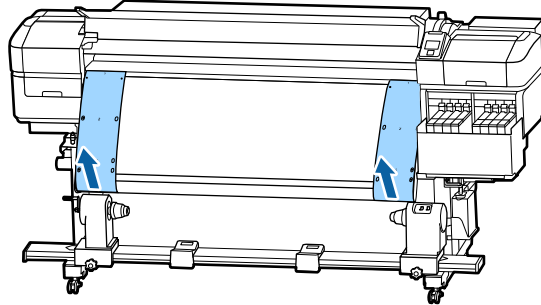

31. Use a damp lint-free cloth to wipe off any dust and lint from the back of the adjustment guides. Roll up the alignment tool and adjustment guides and store them so that they do not become creased.
32. Loosen the left roll core holder locking screw and move both roll core holders inward.

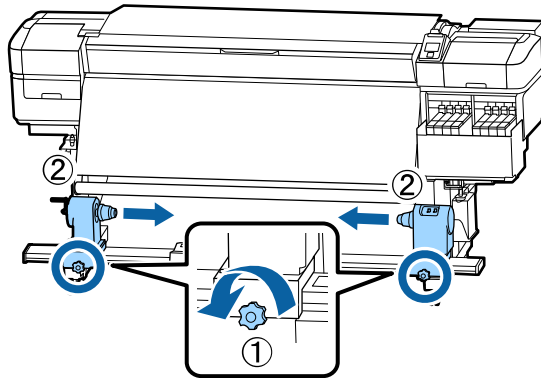

33. Turn the covers as shown and tighten the screws.

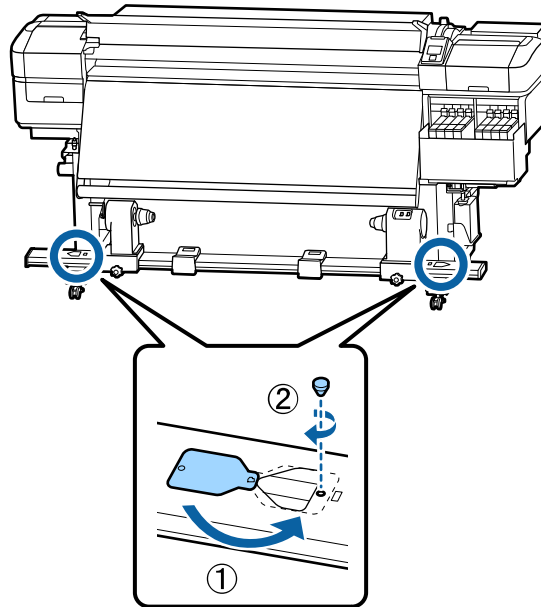

Parent topic: [Solving Media Skew Problems](#)

Related references

[Parallel Adjustment Tools](#)

Solving Print Quality Problems

Check these sections if you have problems with print quality.

[Nozzle Check Pattern Prints Incorrectly](#)

[Print Head Nozzles Remain Clogged](#)

[Overall Print Quality Is Poor](#)

[Printed Media Is Stained or Marred](#)

[Image Is Not Positioned Correctly On the Media](#)

Parent topic: [Solving Problems](#)

Nozzle Check Pattern Prints Incorrectly

If the nozzle check pattern does not print correctly, try these solutions:

- Clean the print head and print the check pattern again.
- Run a light cleaning cycle from the **Maintenance** menu and print the check pattern again. If there are still gaps in the pattern, run a heavy cleaning cycle.
- If the printer has not been used for a long time, nozzles may be dried and clogged. Turn the printer on at least once every two weeks to prevent the nozzles from clogging.

Parent topic: [Solving Print Quality Problems](#)

Related references

[Print Head Nozzles Remain Clogged](#)

Related tasks

[Cleaning the Print Head](#)

[Checking for Clogged Print Head Nozzles](#)

Print Head Nozzles Remain Clogged

If cleaning the print head multiple times does not unclog the print head nozzles, you need to clean the areas shown here:

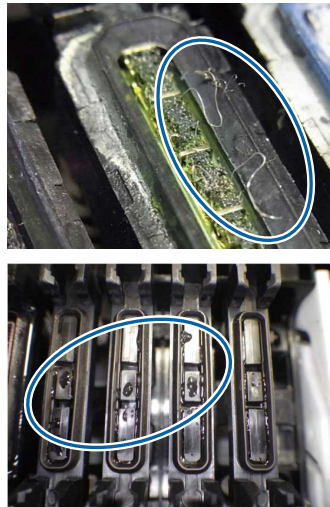

If ink, lint, or dust adheres to the areas shown here, clean these areas or parts inside the printer:

- Around the print head
- Wipers

Parent topic: [Solving Print Quality Problems](#)

Related tasks

[Cleaning Around the Print Heads](#)

[Cleaning the Anti-drying Caps](#)

Overall Print Quality Is Poor

If you notice that your print quality is uneven, too light, too dark, or there are vertical or horizontal lines in the print (banding), try these solutions:

- Run a nozzle check to see if any of the print head nozzles are clogged. Then clean the print head, if necessary.
- Align the print head.
- Adjust the media feed. For the most accurate adjustment, print a test pattern using the **Manual > 500mm Pattern** setting. The same media in a different width may require different adjustment values.
- Use genuine Epson ink packs and make sure the ink packs have not expired.
- Raise the temperature of the after heater, and give the after heater and your media time to warm up before printing again.
- Make sure the media settings in your RIP software are correct for the media you are using.
- Set the **Head Movement** setting to **Printer Full Width** on the product control panel for higher quality printouts.
- If you are comparing the print result with the image on your computer screen, the colors may not match. Since monitors and printers produce colors differently, printed colors and screen colors do not always look the same.
- Make sure that the front cover is closed. Do not open any covers during printing. This can cause the print head to stop abruptly, resulting in uneven color.
- If you print with 1 or 2 passes in the RIP software, reduce the feed speed in the RIP software.
- Check that the media edge guides are installed correctly and are not damaged.
- If you are using the media settings in the product control panel, set the **Feeding Tension** setting to **Lv1**.

Parent topic: [Solving Print Quality Problems](#)

Related references

[Media Setup Menu Settings](#)

[Consumables and Replacement Parts](#)

Related tasks

[Checking for Clogged Print Head Nozzles](#)

[Cleaning the Print Head](#)

[Aligning the Print Head](#)

Printed Media Is Stained or Marred

If the printed media is stained or the surface is marred, try these solutions:

- Make sure the media is not too thick or thin. Check that it meets the media specifications for your product and RIP software.
- Check that the media is not creased or folded, causing it to contact the print head. If necessary, load new media.
- If your media is wavy, press the down arrow button on the product control panel to feed the media past the affected area. Make sure your printing environment is not too hot or humid to avoid wavy media.
- Clean the print head, wiper, and caps as necessary to remove ink that may have stained these parts and transferred to your printout.
- Adjust the **Platen Gap** setting on the product control panel to prevent the print head from striking the media as you print.
- If your printouts contain marks that look like those shown here, the print head is striking the media as you print:



Try these solutions in this order until the results improve:

- Cut off any wrinkled or wavy media and do not load media until you are ready to print.
- Reload the media and check that all of the media settings are correct.
- Reattach the media to the auto take-up reel and make sure the media is taken up correctly.
- Adjust the after heater temperature.

Parent topic: [Solving Print Quality Problems](#)

Related references

[Media Setup Menu Settings](#)

[Media Specifications](#)

[Environmental Specifications](#)

Related tasks

[Loading Media](#)

Related topics

[Using the Auto Take-up Reel](#)

Image Is Not Positioned Correctly On the Media

If the printed image is not positioned correctly on your media, try these solutions:

- Make sure you loaded the media correctly and selected the correct margin and start positions for it on the product control panel.
- Turn on the **Media Skew Check** and **Media Size Check** settings on the product control panel to prevent your image from printing outside the printable area.

Parent topic: [Solving Print Quality Problems](#)

Related references

[Printable Area and Media Size Checking](#)

[Printer Setup Menu Settings](#)

Related tasks

[Loading Media](#)

Uninstall Your Product Software

If you have a problem that requires you to uninstall and re-install your software, follow the instructions for your operating system.

Uninstalling Printing Software - Windows

You can uninstall and then re-install your printer software to solve certain problems.

1. Turn off the product.
2. Disconnect any interface cables.
3. Do one of the following:
 - **Windows 10:** Right-click  and select **Control Panel > Programs > Programs and Features**. Select the uninstall option for your Epson product, then select **Uninstall/Change**.

Note: If you see a **User Account Control** window, click **Yes** or **Continue**.

Select your product again, if necessary, then select **OK**, and click **Yes** to confirm the uninstallation.

- **Windows 8.x:** Navigate to the **Apps** screen and select **Control Panel > Programs > Programs and Features**. Select the uninstall option for your Epson product, then select **Uninstall/Change**.

Note: If you see a **User Account Control** window, click **Yes** or **Continue**.

Select your product again, if necessary, then select **OK**, and click **Yes** to confirm the uninstallation.

- **Windows (other versions):** Click  or **Start**, and select **All Programs** or **Programs**. Select **Epson**, select your product, then click **EPSON Printer Software Uninstall**.

Note: If you see a **User Account Control** window, click **Yes** or **Continue**.

In the next window, select your product and click **OK**. Then follow any on-screen instructions.

4. Restart your computer, then re-install your software.

Note: If re-installing your product software does not solve a problem, contact Epson support.

Where to Get Help

Epson provides technical support and information on the installation, configuration, and operation of professional printing products through the Epson Preferred Limited Warranty Plan. Dial (888) 377-6611, 6 AM to 6 PM, Pacific Time, Monday through Friday. Days and hours of support are subject to change without notice.

Note: If you experience difficulty with the toll-free number, call (562) 276-1305 (U.S.) or (905) 709-3481 (Canada).

Before you call, make sure you have your printer serial number and proof of purchase.

Visit epson.com/support (U.S.) or epson.ca/support (Canada) and select your product for solutions to common problems. You can download drivers, firmware, and documentation, get FAQs and troubleshooting advice, or e-mail Epson with your questions.

Note: For help using any other software on your system, see the documentation for that software for technical support information.

Purchase Supplies and Accessories

You can purchase genuine Epson ink, paper, and accessories from an Epson authorized reseller. To find the nearest reseller, visit proimaging.epson.com (U.S.) or proimaging.epson.ca (Canada), select your product series and product, and click the **Where to Buy** button. Or call 800-GO-EPSON (800-463-7766) in the U.S. or 800-807-7766 in Canada.

Parent topic: [Solving Problems](#)

Technical Specifications

These sections list the technical specifications for your product.

Note: Epson offers a recycling program for end of life Epson products. Please go to [this site](#) (U.S) or [this site](#) (Canada) for information on how to return your Epson products for proper disposal.

[Windows System Requirements](#)

[Printing Specifications](#)

[Electrical Specifications](#)

[Environmental Specifications](#)

[Dimension Specifications](#)

[Interface Specifications](#)

[Ink Pack Specifications](#)

[Media Specifications](#)

[Safety and Approvals Specifications](#)

Windows System Requirements

To use your product and its software, your computer should meet these requirements.

Microsoft Windows OS version (32- and 64-bit compatible)	Windows 10, Windows 8.x, Windows 7
CPU	Core 2 Duo 2.0 GHZ or better
Memory	1GB or more
Hard disk space available	300MB or more
Interface	High-Speed USB Ethernet 1000Base-T
Display resolution	1280 × 1024 or higher

Note: For the latest product software available for your operating system, visit the Epson support site at epson.com/support (U.S.), epson.ca/support (Canada), or epson.com.jm/support (Caribbean), select your product, and select **Downloads**.

Parent topic: [Technical Specifications](#)

Printing Specifications

Printing method	On-demand ink jet
Nozzle configuration	360 nozzles × 2 × 2 rows × 4 colors
Resolution	720 × 1440 dpi maximum
Control code	ESC/P raster (undisclosed command)
Media feed method	Friction feed
Built-in memory	Main memory: 512MB Network: 128MB

Parent topic: [Technical Specifications](#)

Electrical Specifications

Power supply rating	100 to 120 V
Rated frequency range	50/60 Hz
Rated current	10 A
Power consumption	Printing: approximately 570 W (ISO/IEC24712) Ready mode: approximately 340 W Sleep mode: approximately 14 W Power off mode: 1 W

Parent topic: [Technical Specifications](#)

Environmental Specifications

Temperature	Operating: 59 to 95 °F (15 to 35 °C); 59 to 77 °F (15 to 25 °C) recommended Storage (before unpacking): –4 to 140 °F (–20 to 60 °C), no more than 120 hours at 140 °F (60 °C), within a month at 104 °F (40 °C) Storage (after unpacking): –4 to 104 °F (–20 to 40 °C), within a month at 104 °F (40 °C)
Humidity (non-condensing)	Operating: 20 to 80% RH (40 to 60% recommended) Storage (before and after unpacking): 5 to 85% RH

Parent topic: [Technical Specifications](#)

Dimension Specifications

Height	Stored: 52.4 inches (1332 mm) Printing: 65.7 inches (1670 mm)
Width	Stored: 103.1 inches (2620 mm) Printing: 103.1 inches (2620 mm)
Depth	Stored: 36.8 inches (934 mm) Printing: 43.7 inches (1109 mm)
Weight (without ink)	Approximately 639.3 lb (290 kg)

Parent topic: [Technical Specifications](#)

Interface Specifications

USB Interface	Hi-Speed USB-Compatible with the Universal Serial Bus Specifications Revision 2.0
Network Interface	100Base-TX/1000Base-T (requires a shielded twisted pair cable, category 5 or higher)

Parent topic: [Technical Specifications](#)

Ink Pack Specifications

Sublimation transfer ink color	High Density Black, Cyan, Magenta, Yellow
Ink life	Do not use if the date on the package has expired
Print quality guarantee	25 days (from the day the ink tank was refilled from the ink pack)
Temperature	In transit (unopened): –4 to 140 °F (–20 to 60 °C) 1 month at 104 °F (40 °C) 8 hours at 140 °F (60 °C) In storage (opened): 41 to 95 °F (5 to 35 °C); 59 to 77 °F (15 to 25 °C) recommended
Capacity	1000 ml

Parent topic: [Technical Specifications](#)

Related references

[Consumables and Replacement Parts](#)

Media Specifications

Print quality is greatly affected by the type and quality of media used. Always test a sample of media before purchasing large quantities or printing large jobs.

Note: Do not use media that is wrinkled, scratched, torn, or dirty.

Roll core size	2 or 3 inches
Roll outer diameter	Up to 9.8 inches (250 mm)
Media width	11.8 to 64 inches (300 to 1626 mm)
Media thickness	Up to 0.04 inch (1 mm)
Roll weight	Up to 99.2 lb (45 kg)

Parent topic: [Technical Specifications](#)

Safety and Approvals Specifications

United States

Safety: UL60950-1

EMC: FCC part 15 Subpart B class A

Canada

Safety: CAN/CSA C22.2 No. 60950-1

EMC: CAN/CSA-CEI/IEC CISPR 22 Class A

Parent topic: [Technical Specifications](#)

Notices

Check these sections for important notices about your product.

Note: Epson offers a recycling program for end of life Epson products. Please go to [this site](#) (U.S) or [this site](#) (Canada) for information on how to return your Epson products for proper disposal.

[Important Safety Instructions](#)

[FCC Compliance Statement](#)

[Trademarks](#)

[Copyright Notice](#)

Important Safety Instructions

Before using your Epson product, read and follow these safety instructions.

[General Product Safety Instructions](#)

[Ink Pack Safety Instructions](#)

Parent topic: [Notices](#)

General Product Safety Instructions

- Be sure to follow all warnings and instructions marked on the product.
- Use only the type of power source indicated on the product's label.
- Use only the power cord that comes with the product. Use of another cord may cause fires or shock. Do not use the cord with any other equipment.
- Place the product near a wall outlet where the plug can be easily unplugged.
- This product has two power systems. Unplug the two power cords during maintenance to avoid the risk of electric shock.
- Connect your product to a properly grounded power outlet. Avoid plugging the product into an outlet on the same circuit as a photo copier or air control system that regularly switches on and off, or on an outlet controlled by a wall switch or timer.
- Do not let the power cord become damaged or frayed. Place it to avoid abrasions, cuts, fraying, crimping, and kinking. Do not place objects on top of it and do not allow it to be stepped on or run over. Be careful to keep the cord straight at each end.

- If you use an extension cord with the product, make sure the total ampere rating of the devices plugged into the extension cord does not exceed the cord's ampere rating. Also, make sure the total ampere rating of all devices plugged into the wall outlet does not exceed the wall outlet's ampere rating.
- If damage occurs to the plug, replace the cord set or consult a qualified electrician. If there are fuses in the plug, make sure you replace them with fuses of the correct size and rating.
- Always turn off the product using the power button, and wait until the power light stops flashing before unplugging the product or cutting off power to the electrical outlet.
- If you will not be using the product for a long period, unplug the power cord from the electrical outlet.
- Place the product on a flat, stable surface that extends beyond its base in all directions. It will not operate properly if it is tilted or at an angle.
- Avoid locations that are subject to rapid changes in heat or humidity, shocks or vibrations, or dust.
- Do not place or store the product outdoors.
- Do not place the product near excessive heat sources or in direct sunlight.
- Leave enough room around the product for sufficient ventilation. Do not block or cover openings in the cabinet or insert objects through the slots.
- Keep the product away from potential sources of electromagnetic interference, such as loudspeakers or the base units of cordless telephones.
- When connecting the product to a computer or other device with a cable, ensure the correct orientation of the connectors. Each connector has only one correct orientation. Inserting a connector in the wrong orientation may damage both devices connected by the cable.
- Do not move the print head by hand; this may damage the product.
- Do not spill liquid on the product or use the product with wet hands.
- Do not use aerosol products that contain flammable gases inside or around the product. Doing so may cause fire.
- Except as specifically explained in your documentation, do not attempt to service the product yourself.
- Unplug the product and refer servicing to qualified service personnel under the following conditions: if the power cord or plug is damaged; if liquid has entered the product; if the product has been dropped or the cabinet damaged; if the product does not operate normally or exhibits a distinct change in performance. Adjust only those controls that are covered by the operating instructions.
- When storing or transporting the product, do not tilt it, stand it on its side, or turn it upside down; otherwise ink may leak.

Note: The lithium batteries in this product contain Perchlorate Material - special handling may apply. [Click here](#) for details.

Parent topic: [Important Safety Instructions](#)

Ink Pack Safety Instructions

- Keep ink packs out of the reach of children and do not drink the ink.
- Wear protective eyewear, gloves, and a mask when performing maintenance.
- Should ink touch your skin or enter your eyes or mouth, immediately take the following actions:
 - If fluid touches your skin, wash it off immediately with large volumes of soapy water. Consult a physician if the skin appears irritated or discolored.
 - If fluid gets in your eyes, rinse immediately with water. Failure to observe this precaution could result in bloodshot eyes or mild inflammation. If problems persist, consult with a physician.
 - If swallowed, do not induce vomiting and consult with a physician as soon as possible.
 - If fluid gets in your mouth, consult a physician as soon as possible.

Parent topic: [Important Safety Instructions](#)

FCC Compliance Statement

For United States Users

This equipment has been tested and found to comply with the limits for a Class A digital device, pursuant to Part 15 of the FCC Rules. These limits are designed to provide reasonable protection against harmful interference when the equipment is operated in a commercial environment. This equipment generates, uses, and can radiate radio frequency energy and, if not installed and used in accordance with the instruction manual, may cause harmful interference to radio communications. Operation of this equipment in a residential area is likely to cause harmful interference, in which case the user will be required to correct the interference at his own expense.

This device complies with Part 15 of the FCC Rules. Operation is subject to the following two conditions:

1. this device may not cause harmful interference, and
2. this device must accept any interference received, including interference that may cause undesired operation.

WARNING

The connection of a non-shielded equipment interface cable to this equipment will invalidate the FCC Certification of this device and may cause interference levels which exceed the limits established by the FCC for this equipment. It is the responsibility of the user to obtain and use a shielded equipment interface cable with this device. If this equipment has more than one interface connector, do not leave cables connected to unused interfaces. Changes or modifications not expressly approved by the manufacturer could void the user's authority to operate the equipment.

For Canadian Users

This Class A digital apparatus complies with Canadian ICES-003.

Cet appareil numérique de la classe A est conforme à la norme NMB-003 du Canada.

WARNING

This is a Class A product. In a domestic environment this product may cause radio interference, in which case the user may be required to take adequate measures.

Parent topic: [Notices](#)

Trademarks

EPSON® and SureColor® are registered trademarks, and EPSON Exceed Your Vision is a registered logomark of Seiko Epson Corporation.

General Notice: Other product names used herein are for identification purposes only and may be trademarks of their respective owners. Epson disclaims any and all rights in those marks.



Parent topic: [Notices](#)

Copyright Notice

All rights reserved. No part of this publication may be reproduced, stored in a retrieval system, or transmitted in any form or by any means, electronic, mechanical, photocopying, recording, or otherwise, without the prior written permission of Seiko Epson Corporation. The information contained herein is designed only for use with this Epson product. Epson is not responsible for any use of this information as applied to other products.

Neither Seiko Epson Corporation nor its affiliates shall be liable to the purchaser of this product or third parties for damages, losses, costs, or expenses incurred by purchaser or third parties as a result of: accident, misuse, or abuse of this product or unauthorized modifications, repairs, or alterations to this product, or (excluding the U.S.) failure to strictly comply with Seiko Epson Corporation's operating and maintenance instructions.

Seiko Epson Corporation shall not be liable for any damages or problems arising from the use of any options or any consumable products other than those designated as Original Epson Products or Epson Approved Products by Seiko Epson Corporation.

Seiko Epson Corporation shall not be held liable for any damage resulting from electromagnetic interference that occurs from the use of any interface cables other than those designated as Epson approved Products by Seiko Epson Corporation.

This information is subject to change without notice.

[A Note Concerning Responsible Use of Copyrighted Materials](#)
[Copyright Attribution](#)

Parent topic: [Notices](#)

A Note Concerning Responsible Use of Copyrighted Materials

Epson encourages each user to be responsible and respectful of the copyright laws when using any Epson product. While some countries' laws permit limited copying or reuse of copyrighted material in certain circumstances, those circumstances may not be as broad as some people assume. Contact your legal advisor for any questions regarding copyright law.

Parent topic: [Copyright Notice](#)

Copyright Attribution

© 2017 Epson America, Inc.

10/17

CPD-54298R1

Parent topic: [Copyright Notice](#)