

Galaxy VS

Battery Breaker Box

Installation

10/2018



Legal Information

The Schneider Electric brand and any registered trademarks of Schneider Electric Industries SAS referred to in this guide are the sole property of Schneider Electric SA and its subsidiaries. They may not be used for any purpose without the owner's permission, given in writing. This guide and its content are protected, within the meaning of the French intellectual property code (Code de la propriété intellectuelle français, referred to hereafter as "the Code"), under the laws of copyright covering texts, drawings and models, as well as by trademark law. You agree not to reproduce, other than for your own personal, noncommercial use as defined in the Code, all or part of this guide on any medium whatsoever without Schneider Electric's permission, given in writing. You also agree not to establish any hypertext links to this guide or its content. Schneider Electric does not grant any right or license for the personal and noncommercial use of the guide or its content, except for a non-exclusive license to consult it on an "as is" basis, at your own risk. All other rights are reserved.

Electrical equipment should be installed, operated, serviced, and maintained only by qualified personnel. No responsibility is assumed by Schneider Electric for any consequences arising out of the use of this material.

As standards, specifications, and designs change from time to time, please ask for confirmation of the information given in this publication.



Go to

https://www.productinfo.schneider-electric.com/portals/ui/galaxyvs_iec/
or scan the QR code above for digital experience and translated manuals.

Table of Contents

Important Safety Instructions — SAVE THESE INSTRUCTIONS	5
Electromagnetic Compatibility.....	6
Safety Precautions	6
Electrical Safety.....	8
Battery Safety.....	9
Specifications	11
Battery Breaker Specifications	11
Trip Settings	12
Recommended Cable Sizes	13
Torque Specifications.....	13
Battery Breaker Box Weights and Dimensions	14
Environment.....	14
Overview of Supplied Installation Kits.....	15
Installation Procedure	16
Mount the Battery Breaker Box to the Wall	17
Prepare the Battery Breaker Box for Cables.....	19
Connect the Signal Cables	21
Connect the Power Cables.....	24
Add Translated Safety Labels to Your Product.....	27
Final Installation Steps.....	28

Important Safety Instructions — SAVE THESE INSTRUCTIONS

Read these instructions carefully and look at the equipment to become familiar with it before trying to install, operate, service or maintain it. The following safety messages may appear throughout this manual or on the equipment to warn of potential hazards or to call attention to information that clarifies or simplifies a procedure.



The addition of this symbol to a “Danger” or “Warning” safety message indicates that an electrical hazard exists which will result in personal injury if the instructions are not followed.



This is the safety alert symbol. It is used to alert you to potential personal injury hazards. Obey all safety messages with this symbol to avoid possible injury or death.

⚠ DANGER
DANGER indicates a hazardous situation which, if not avoided, will result in death or serious injury.
Failure to follow these instructions will result in death or serious injury.

⚠ WARNING
WARNING indicates a hazardous situation which, if not avoided, could result in death or serious injury.
Failure to follow these instructions can result in death, serious injury, or equipment damage.

⚠ CAUTION
CAUTION indicates a hazardous situation which, if not avoided, could result in minor or moderate injury.
Failure to follow these instructions can result in injury or equipment damage.

NOTICE
NOTICE is used to address practices not related to physical injury. The safety alert symbol shall not be used with this type of safety message.
Failure to follow these instructions can result in equipment damage.

Please Note

Electrical equipment should only be installed, operated, serviced, and maintained by qualified personnel. No responsibility is assumed by Schneider Electric for any consequences arising out of the use of this material.

A qualified person is one who has skills and knowledge related to the construction, installation, and operation of electrical equipment and has received safety training to recognize and avoid the hazards involved.

Electromagnetic Compatibility

NOTICE

RISK OF ELECTROMAGNETIC DISTURBANCE

This is a product category C2 UPS product. In a residential environment, this product may cause radio interference, in which case the user may be required to take additional measures.

Failure to follow these instructions can result in equipment damage.

Safety Precautions

⚠ DANGER

HAZARD OF ELECTRIC SHOCK, EXPLOSION, OR ARC FLASH

Read all instructions in the installation manual before installing or working on this product.

Failure to follow these instructions will result in death or serious injury.

⚠ DANGER

HAZARD OF ELECTRIC SHOCK, EXPLOSION, OR ARC FLASH

Do not install the product until all construction work has been completed and the installation room has been cleaned.

Failure to follow these instructions will result in death or serious injury.

⚠ DANGER

HAZARD OF ELECTRIC SHOCK, EXPLOSION, OR ARC FLASH

The product must be installed according to the specifications and requirements as defined by Schneider Electric. It concerns in particular the external and internal protections (upstream breakers, battery breakers, cabling, etc.) and environmental requirements. No responsibility is assumed by Schneider Electric if these requirements are not respected.

Failure to follow these instructions will result in death or serious injury.

⚠ DANGER

HAZARD OF ELECTRIC SHOCK, EXPLOSION, OR ARC FLASH

The UPS system must be installed according to local and national regulations. Install the UPS according to:

- IEC 60364 (including 60364-4-41- protection against electric shock, 60364-4-42 - protection against thermal effect, and 60364-4-43 - protection against overcurrent), **or**
- NEC NFPA 70, **or**
- Canadian Electrical Code (C22.1, Part 1)

depending on which one of the standards apply in your local area.

Failure to follow these instructions will result in death or serious injury.

⚠ DANGER

HAZARD OF ELECTRIC SHOCK, EXPLOSION, OR ARC FLASH

- Install the product in a temperature controlled indoor environment free of conductive contaminants and humidity.
- Install the product on a non-flammable, level and solid surface (e.g. concrete) that can support the weight of the system.

Failure to follow these instructions will result in death or serious injury.

⚠ DANGER

HAZARD OF ELECTRIC SHOCK, EXPLOSION, OR ARC FLASH

The product is not designed for and must therefore not be installed in the following unusual operating environments:

- Damaging fumes
- Explosive mixtures of dust or gases, corrosive gases, or conductive or radiant heat from other sources
- Moisture, abrasive dust, steam or in an excessively damp environment
- Fungus, insects, vermin
- Salt-laden air or contaminated cooling refrigerant
- Pollution degree higher than 2 according to IEC 60664-1
- Exposure to abnormal vibrations, shocks, and tilting
- Exposure to direct sunlight, heat sources, or strong electromagnetic fields

Failure to follow these instructions will result in death or serious injury.

⚠ DANGER

HAZARD OF ELECTRIC SHOCK, EXPLOSION, OR ARC FLASH

Do not drill or cut holes for cables or conduits with the gland plates installed and do not drill or cut holes in close proximity to the UPS.

Failure to follow these instructions will result in death or serious injury.

⚠ WARNING

HAZARD OF ARC FLASH

Do not make mechanical changes to the product (including removal of cabinet parts or drilling/cutting of holes) that are not described in the installation manual.

Failure to follow these instructions can result in death, serious injury, or equipment damage.

NOTICE

RISK OF OVERHEATING

Respect the space requirements around the product and do not cover the ventilation openings when the product is in operation.

Failure to follow these instructions can result in equipment damage.

Electrical Safety

⚠ DANGER

HAZARD OF ELECTRIC SHOCK, EXPLOSION, OR ARC FLASH

- Electrical equipment must be installed, operated, serviced, and maintained only by qualified personnel.
- Apply appropriate personal protective equipment (PPE) and follow safe electrical work practices.
- Turn off all power supplying the UPS system before working on or inside the equipment.
- Before working on the UPS system, check for hazardous voltage between all terminals including the protective earth.
- The UPS contains an internal energy source. Hazardous voltage can be present even when disconnected from the mains supply. Before installing or servicing the UPS system, ensure that the units are OFF and that mains and batteries are disconnected. Wait five minutes before opening the UPS to allow the capacitors to discharge.
- The UPS must be properly earthed/grounded and due to a high leakage current, the earthing/grounding conductor must be connected first.

Failure to follow these instructions will result in death or serious injury.

⚠ DANGER

HAZARD OF ELECTRIC SHOCK, EXPLOSION, OR ARC FLASH

In systems where backfeed protection is not part of the standard design, an automatic isolation device (backfeed protection option or other device meeting the requirements of IEC/EN 62040-1 or UL1778 5th Edition – depending on which of the two standards apply to your local area) must be installed to prevent hazardous voltage or energy at the input terminals of the isolation device. The device must open within 15 seconds after the upstream power supply fails and must be rated according to the specifications.

Failure to follow these instructions will result in death or serious injury.

When the UPS input is connected through external isolators that, when opened, isolate the neutral or when the automatic backfeed isolation is provided external to the equipment or is connected to an IT power distribution system, a label must be fitted at the UPS input terminals, and on all primary power isolators installed remote from the UPS area and on external access points between such isolators and the UPS, by the user, displaying the following text (or equivalent in a language which is acceptable in the country in which the UPS system is installed):

⚠ DANGER

HAZARD OF ELECTRIC SHOCK, EXPLOSION, OR ARC FLASH

Risk of Voltage Backfeed. Before working on this circuit: Isolate the UPS and check for hazardous voltage between all terminals including the protective earth.

Failure to follow these instructions will result in death or serious injury.

Battery Safety

⚠ DANGER

HAZARD OF ELECTRIC SHOCK, EXPLOSION OR ARC FLASH

- Battery circuit breakers must be installed according to the specifications and requirements as defined by Schneider Electric.
- Servicing of batteries must only be performed or supervised by qualified personnel knowledgeable of batteries and the required precautions. Keep unqualified personnel away from batteries.
- Disconnect charging source prior to connecting or disconnecting battery terminals.
- Do not dispose of batteries in a fire as they can explode.
- Do not open, alter, or mutilate batteries. Released electrolyte is harmful to the skin and eyes. It may be toxic.

Failure to follow these instructions will result in death or serious injury.

⚠ DANGER

HAZARD OF ELECTRIC SHOCK, EXPLOSION, OR ARC FLASH

Batteries can present a risk of electric shock and high short-circuit current. The following precautions must be observed when working on batteries

- Remove watches, rings, or other metal objects.
- Use tools with insulated handles.
- Wear protective glasses, gloves and boots.
- Do not lay tools or metal parts on top of batteries.
- Disconnect the charging source prior to connecting or disconnecting battery terminals.
- Determine if the battery is inadvertently grounded. If inadvertently grounded, remove source from ground. Contact with any part of a grounded battery can result in electric shock. The likelihood of such shock can be reduced if such grounds are removed during installation and maintenance (applicable to equipment and remote battery supplies not having a grounded supply circuit).

Failure to follow these instructions will result in death or serious injury.

⚠ DANGER

HAZARD OF ELECTRIC SHOCK, EXPLOSION, OR ARC FLASH

When replacing batteries, always replace with the same type and number of batteries or battery packs. Refer to the label in the classic battery cabinet for information on batteries in your system.

Failure to follow these instructions will result in death or serious injury.

▲ CAUTION**RISK OF EQUIPMENT DAMAGE**

- Wait until the system is ready to be powered up before installing batteries in the system. The time duration from battery installation until the UPS system is powered up must not exceed 72 hours or 3 days.
- Batteries must not be stored more than six months due to the requirement of recharging. If the UPS system remains de-energized for a long period, we recommend that you energize the UPS system for a period of 24 hours at least once every month. This charges the batteries, thus avoiding irreversible damage.

Failure to follow these instructions can result in injury or equipment damage.

Specifications

NOTICE
<p>HAZARD OF EQUIPMENT DAMAGE</p> <p>Refer to the UPS installation manual for detailed specifications for the UPS system.</p> <p>Failure to follow these instructions can result in equipment damage.</p>

Battery Breaker Specifications

⚠ DANGER
<p>HAZARD OF ELECTRIC SHOCK, EXPLOSION OR ARC FLASH</p> <p>This product must only be used with the Galaxy VS UPS.</p> <p>Failure to follow these instructions will result in death or serious injury.</p>

Breaker rating	20–80 kW	100–200 kW
Battery breaker	LV438980 (LV438218, LV438245)	LV438279
Maximum configuration	4 hour runtime	200 kW: 1 hour runtime 100-150 kW: 4 hour runtime
Battery type	Lead-acid, VRLA, Lithium-Ion	Lead-acid, VRLA, Lithium-Ion
Maximum battery short-circuit level (kA)	35	35
Minimum short-circuit current to trip circuit breaker (A)	1250	1600

Trip Settings

Trip Settings for 20–80 kW Battery Breaker

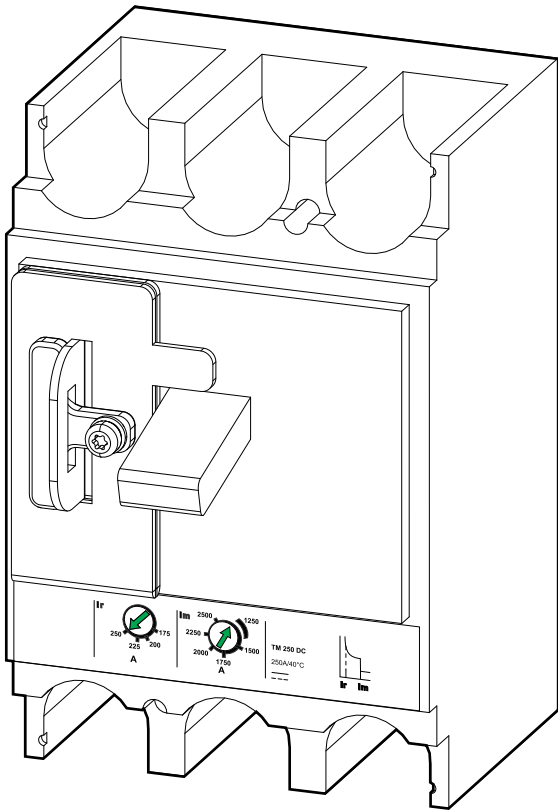

Trip Settings for 100–200 kW Battery Breaker

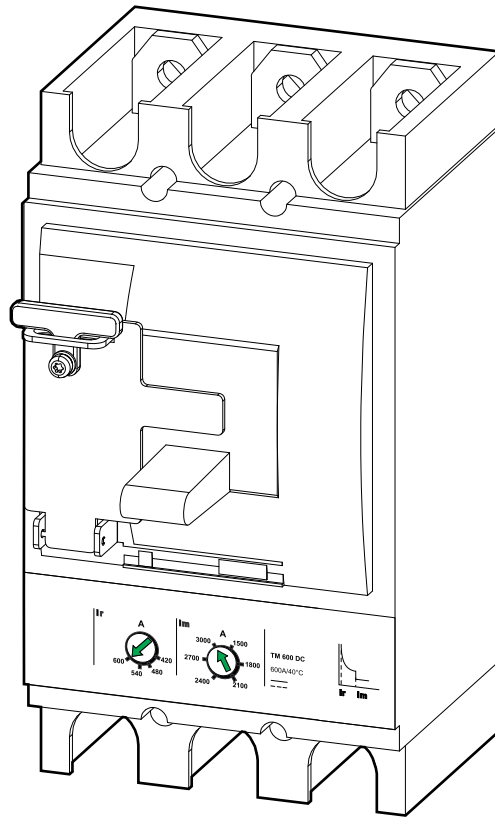

UPS rating	20–60 kW	80 kW	100–150 kW	200 kW
Ir (A)	175	225	420	600
Im (A)	1250	1250	1500	1500

Recommended Cable Sizes

⚠ DANGER

HAZARD OF ELECTRIC SHOCK, EXPLOSION, OR ARC FLASH

All wiring must comply with all applicable national and/or electrical codes.

Failure to follow these instructions will result in death or serious injury.

NOTE: Overcurrent protection is to be provided by others.

Cable sizes in this manual are based on table B.52.5 of IEC 60364–5–52 with the following assertions:

- 90 °C conductors
- An ambient temperature of 30 °C
- Use of copper or aluminium conductors
- Installation method C

If the ambient temperature is greater than 30 °C, larger conductors are to be selected in accordance with the correction factors of the IEC.

Copper	20–60 kW	80 kW	100–150 kW	200 kW
Battery +/- (mm ²)	50	70	2 x 70	2 x 120
Battery PE (mm ²)	25	35	70	120

Aluminum	20–60 kW	80 kW	100–150 kW	200 kW
Battery +/- (mm ²)	70	NA	2 x 120	NA
Battery PE (mm ²)	35	NA	120	NA

Torque Specifications

Bolt size	Torque
M4	1.7 Nm (1.25 lb-ft)
M6	5 Nm (3.69 lb-ft)
M8	17.5 Nm (12.91 lb-ft)
M10	30 Nm (22 lb-ft)

Battery Breaker Box Weights and Dimensions







	Weight kg	Height mm	Width mm	Depth mm
10–80 kW battery breaker box	25	650	500	280
100–200 kW battery breaker box	35	800	500	280

Environment





	Operating	Storage
Temperature	0 °C to 40 °C	-25 °C to 55 °C
Relative humidity	0 – 95% non-condensing	0 – 95% non-condensing
Protection class	IP20	
Color	RAL 9003, gloss level 85%	

Overview of Supplied Installation Kits

Installation Kit 0H-9130 for 20–80 kVA

Part	Used in	Number of units
M10 nut with washer	<i>Mount the Battery Breaker Box to the Wall, page 17.</i>	7 
M10 x 30 mm bolt with washer		7 
M8 nut with washer	<i>Connect the Power Cables, page 24.</i>	15 
M8 x 25 mm bolt with washer		15 
Cable ties for signal cables	<i>Connect the Signal Cables, page 21.</i>	2 
Cables ties for signal cables		5 
Cables ties for power cables	<i>Connect the Power Cables, page 24.</i>	30 

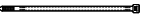
Installation Kit 0H-1491 for 100–200 kVA

Part	Used in	Number of units
M10 nut with washer	<i>Mount the Battery Breaker Box to the Wall, page 17 and Connect the Power Cables, page 24.</i>	15 
M10 x 30 mm bolt with washer		15 
Cable ties for signal cables	<i>Connect the Signal Cables, page 21.</i>	2 
Cables ties for signal cables		5 
Cables ties for power cables	<i>Connect the Power Cables, page 24</i>	30 

Installation Procedure

⚠ DANGER

HAZARD OF ELECTRIC SHOCK, EXPLOSION OR ARC FLASH

Place the battery breaker box as close to the battery bank as possible to limit the length of unprotected battery cable. The distance between the battery bank and the UPS must not exceed 200 m. Contact Schneider Electric for installations with a longer distance.

Failure to follow these instructions will result in death or serious injury.

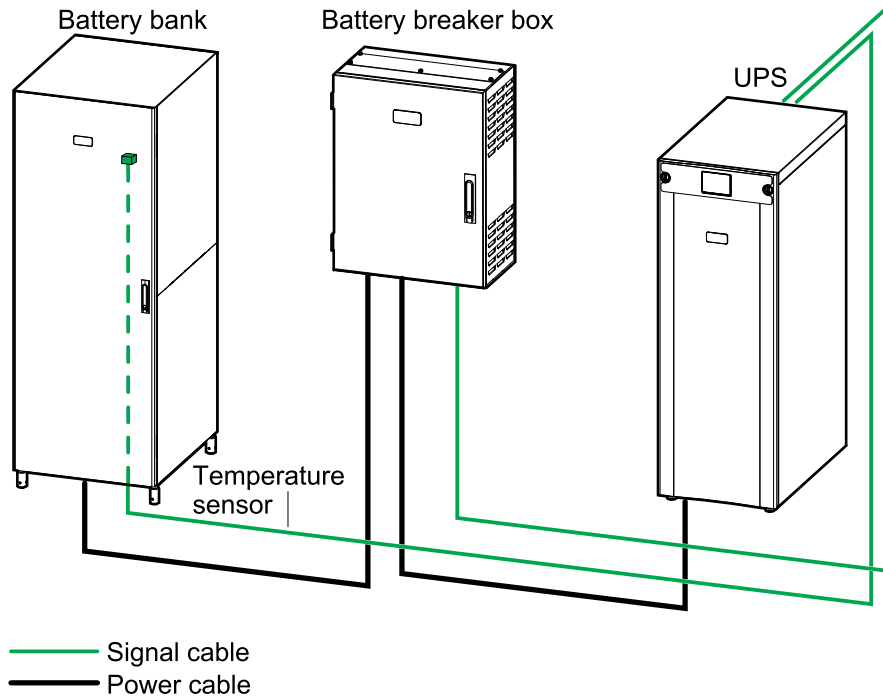

1. *Mount the Battery Breaker Box to the Wall, page 17.*
2. *Prepare the Battery Breaker Box for Cables, page 19.*
3. *Connect the Signal Cables, page 21.*
4. *Connect the Power Cables, page 24.*
5. *Add Translated Safety Labels to Your Product, page 27.*
6. *Final Installation Steps, page 28.*

Mount the Battery Breaker Box to the Wall

⚠ CAUTION

RISK OF INJURY OR EQUIPMENT DAMAGE

- Mount the battery breaker box to a wall or a rack that is structurally sound and able to support the weight of the unit.
- Use appropriate hardware (not supplied) to mount the battery breaker box to the wall.

Failure to follow these instructions can result in injury or equipment damage.

NOTE: Four M10 x 30 torx and nuts are supplied for mounting the battery breaker box to a rack.

20–80 kW Battery Breaker Box

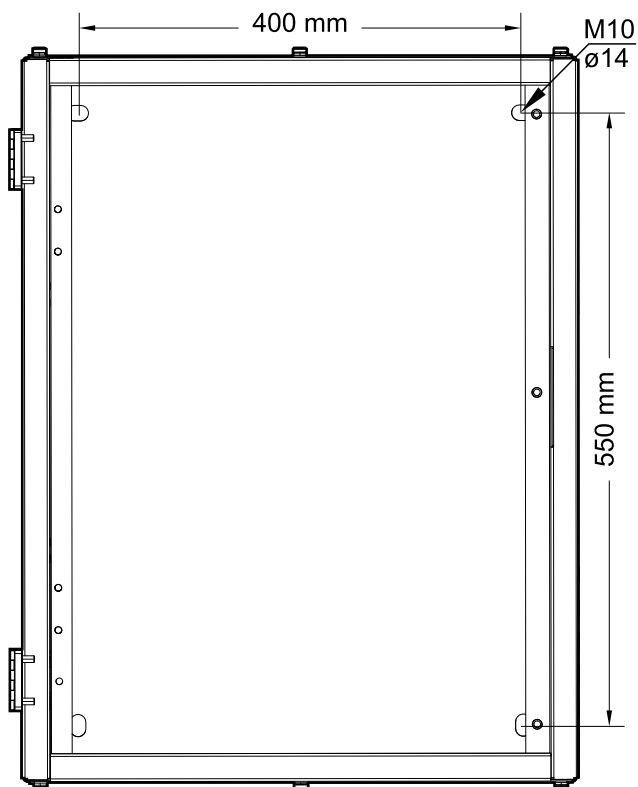

100–200 kW Battery Breaker Box

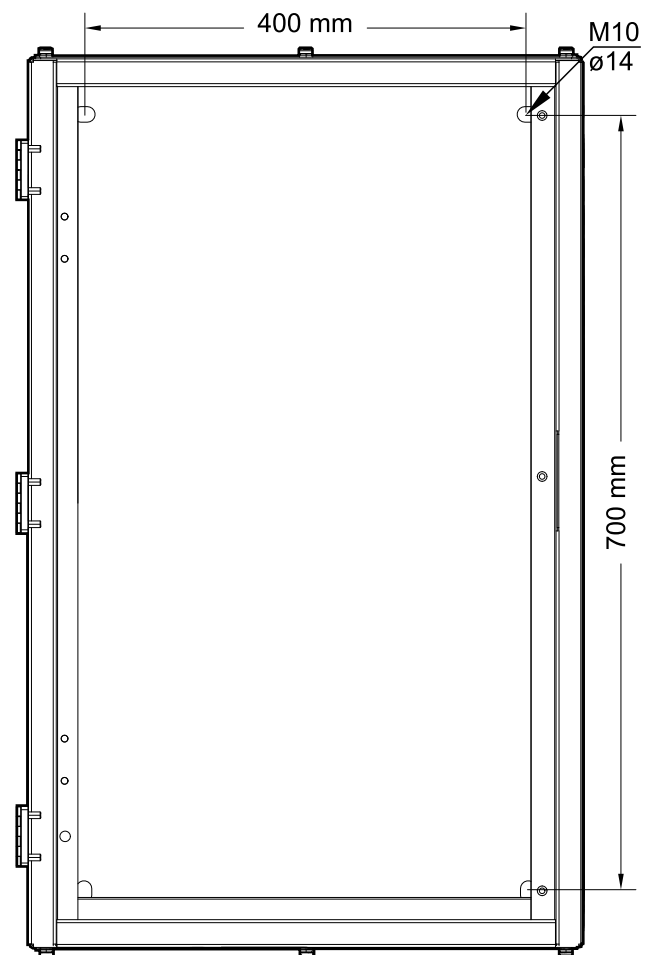

1. Measure and mark the four mounting hole locations on the wall.
2. Drill holes in each of the four marked locations.

3. Loosen the three screws and open the inner door.

Front View of the Battery Breaker Box

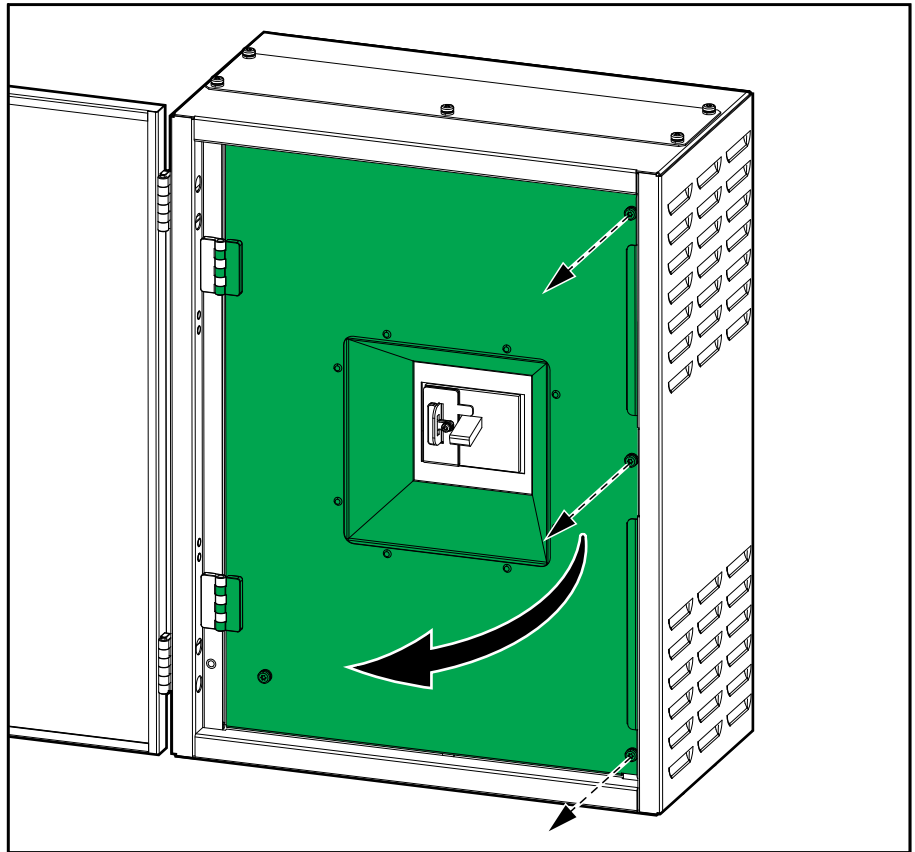

4. Line up the battery breaker box with the four holes on the wall and mount the battery breaker box to the wall.

Prepare the Battery Breaker Box for Cables

⚠ DANGER

HAZARD OF ELECTRIC SHOCK, EXPLOSION, OR ARC FLASH

Do not drill or punch holes for cables or grommets with the gland plates installed, and do not drill or punch in close proximity to the UPS.

Failure to follow these instructions will result in death or serious injury.

1.

- **For bottom cable entry:** Loosen the bolts from the bottom gland plate and remove the bottom gland plate.
- **For top cable entry – only available for the 20–80 kW battery breaker box:** Loosen the bolts from the top gland plate and remove the top gland plate.

Front Bottom View of the 20–80 kW Battery Breaker Box

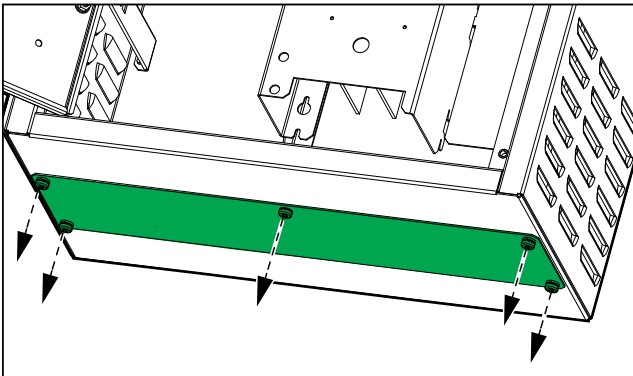

Front Bottom View of the 100–200 kW Battery Breaker Box

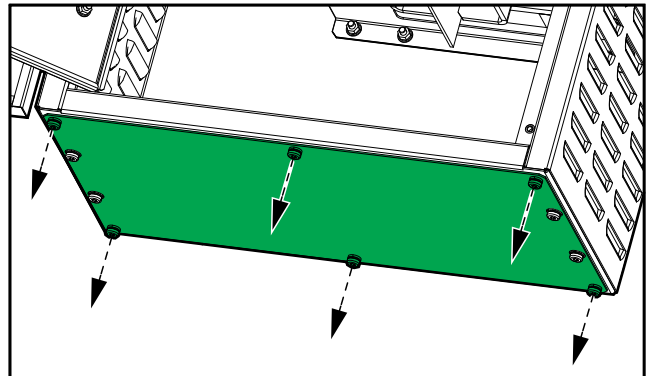

Front Top View of the 20–80 kW Battery Breaker Box

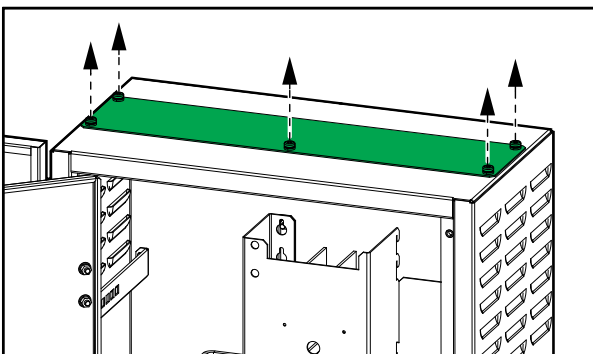

2. Drill or punch holes for cables or grommets in the gland plate(s).

3. Install grommets (if applicable) and refit the gland plate(s).

⚠ DANGER
HAZARD OF ELECTRIC SHOCK, EXPLOSION, OR ARC FLASH
Ensure that there are no sharp edges that can damage the cables.
Failure to follow these instructions will result in death or serious injury.

Front Bottom View of the 20–80 kW Battery Breaker Box

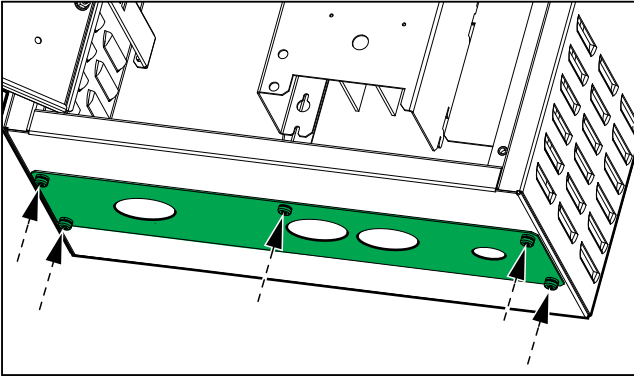

Front Bottom View of the 100–200 kW Battery Breaker Box

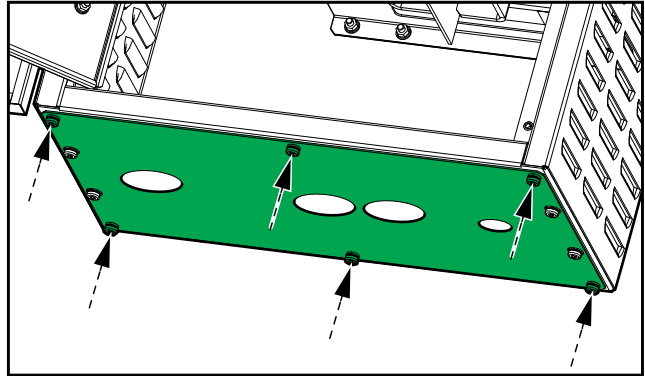

Front Top View of the 20–80 kW Battery Breaker Box

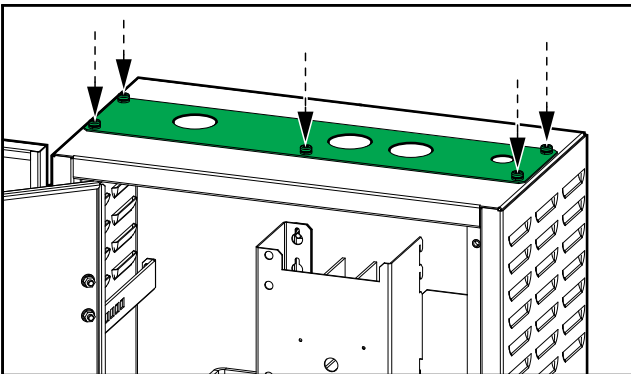

Connect the Signal Cables

1. Loosen the screws of the protection covers and lift the protection covers up and out of the battery breaker box.

Front View of the 20–80 kW Battery Breaker Box

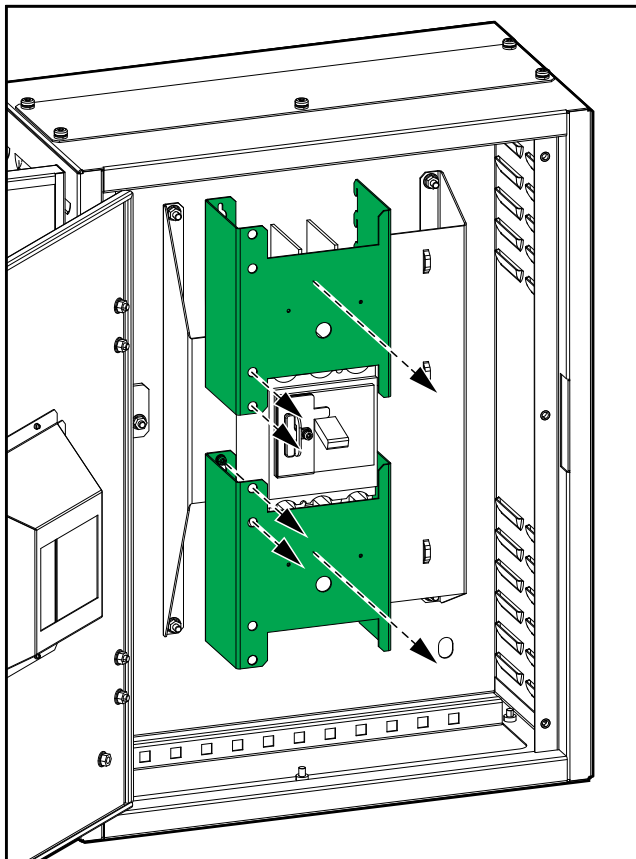

Front View of the 100–200 kW Battery Breaker Box

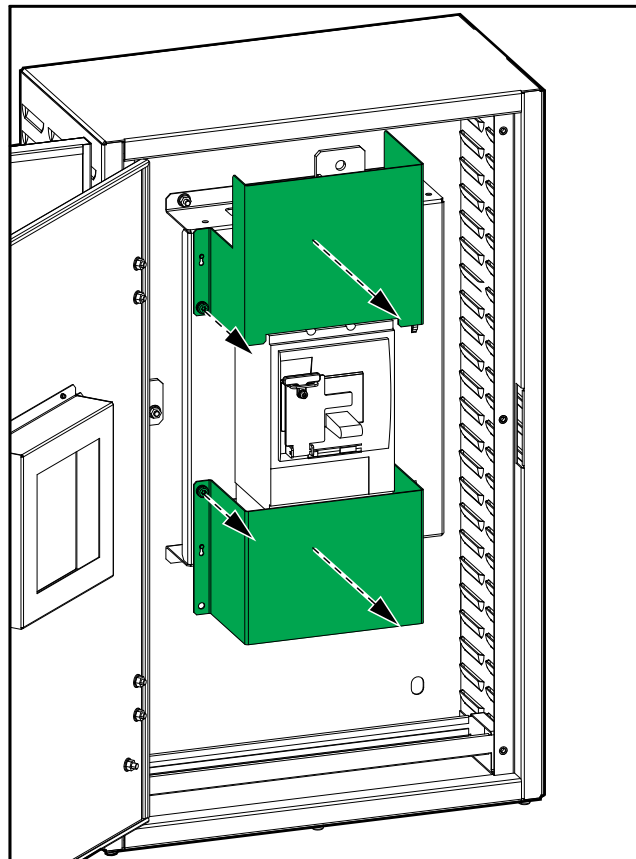

2. Route the signal cables through the bottom of the battery breaker box. For the 20–80 kW you can also route the signal cables through the top of the battery breaker box.

3. Remove the cover on the battery breaker.

Front View of the Battery Breaker Box

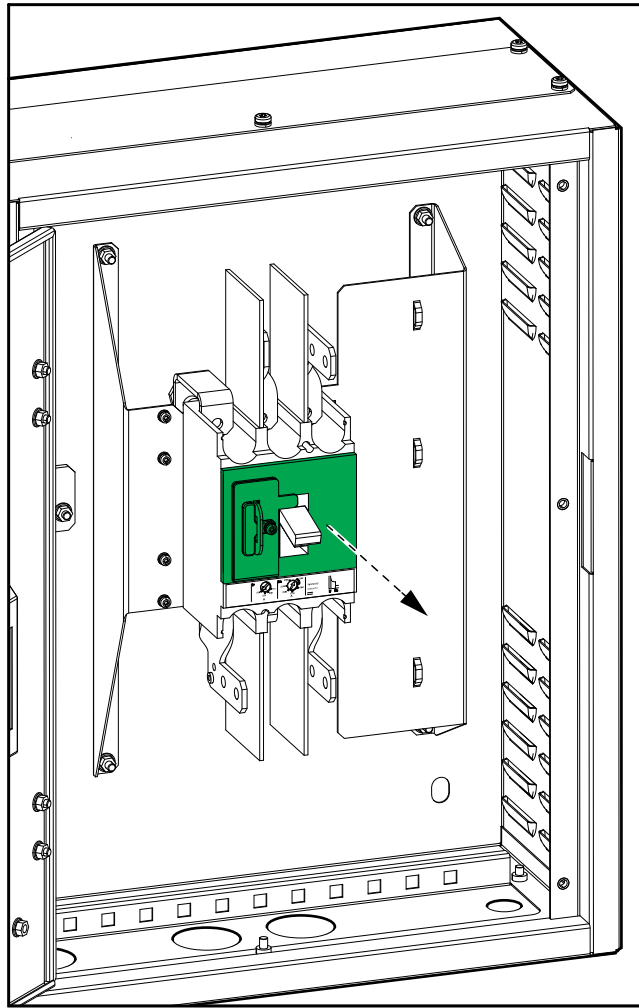

4. Connect the signal cables:
 - a. Connect the signal cables to the AUX switch.
 - b. Connect the signal cables to the undervoltage trip coil.
 - c. Fasten the signal cables with cable ties (provided) to the cable relief.

Front View of the Battery Breaker Box

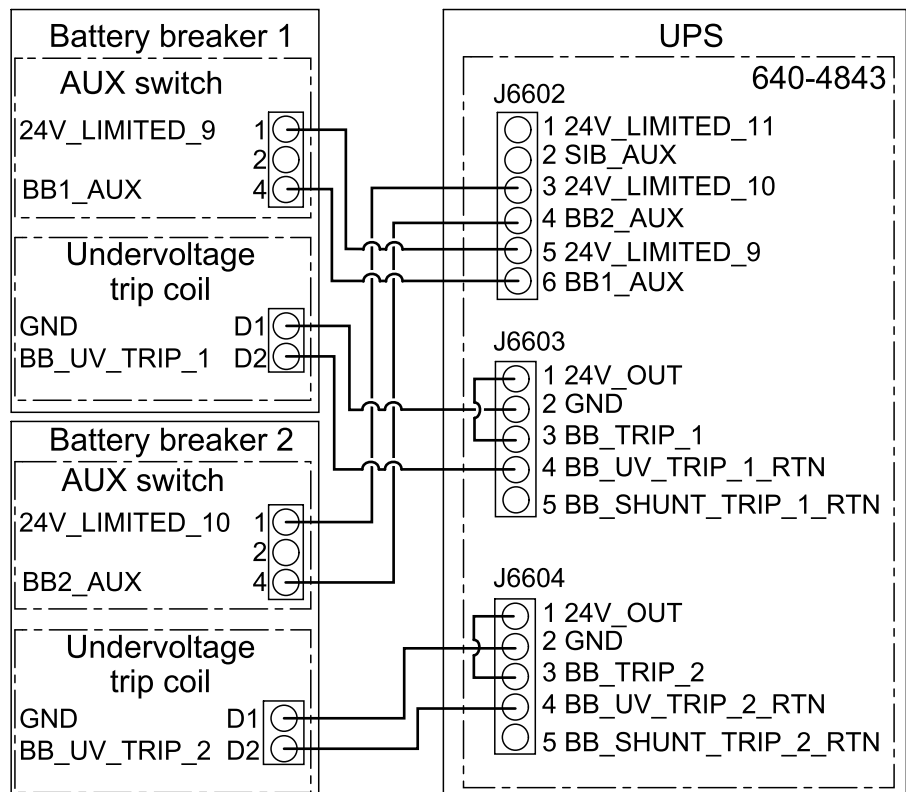
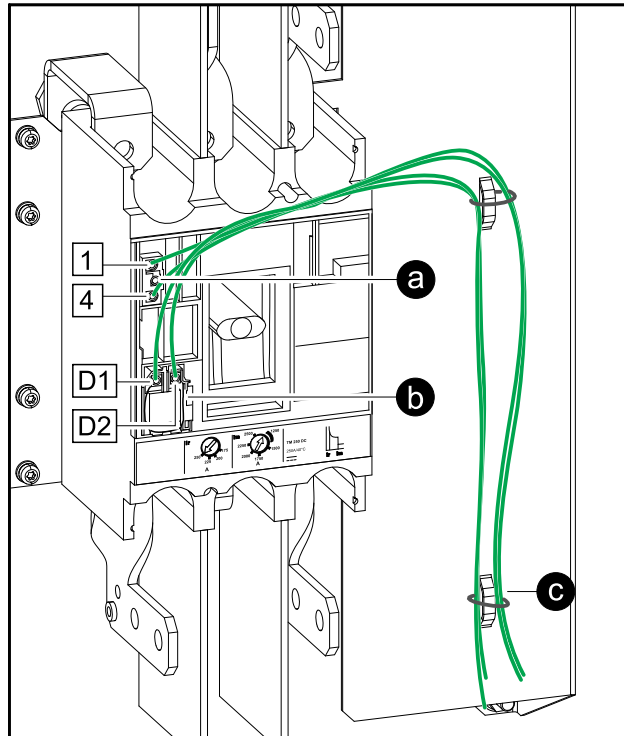

5. Reinstall the cover on the battery breaker.
6. Route the signal cables separately from the power cables.

Connect the Power Cables

⚠ DANGER

HAZARD OF ELECTRIC SHOCK, EXPLOSION, OR ARC FLASH

Perform a total power off of the UPS system before connecting the battery cables to the battery breaker box.

Failure to follow these instructions will result in death or serious injury.

⚠ DANGER

HAZARD OF ELECTRIC SHOCK, EXPLOSION, OR ARC FLASH

For TT and TN systems each stand alone cabinet of the system must be individually connected to the protective earthing terminal in the distribution board that supplies the system.

Failure to follow these instructions will result in death or serious injury.

⚠ WARNING

HAZARD OF ARC FLASH

Use the provided M10 bolts and nuts to connect the power cables.

Failure to follow these instructions can result in death, serious injury, or equipment damage.

1. Lockout/Tagout the battery breaker.

2. Route the PE cables from the UPS cabinet through either the top or bottom of the battery breaker box and connect.

Cables from the UPS Cabinet Routed through the Top of the 20–80 kW Battery Breaker Box

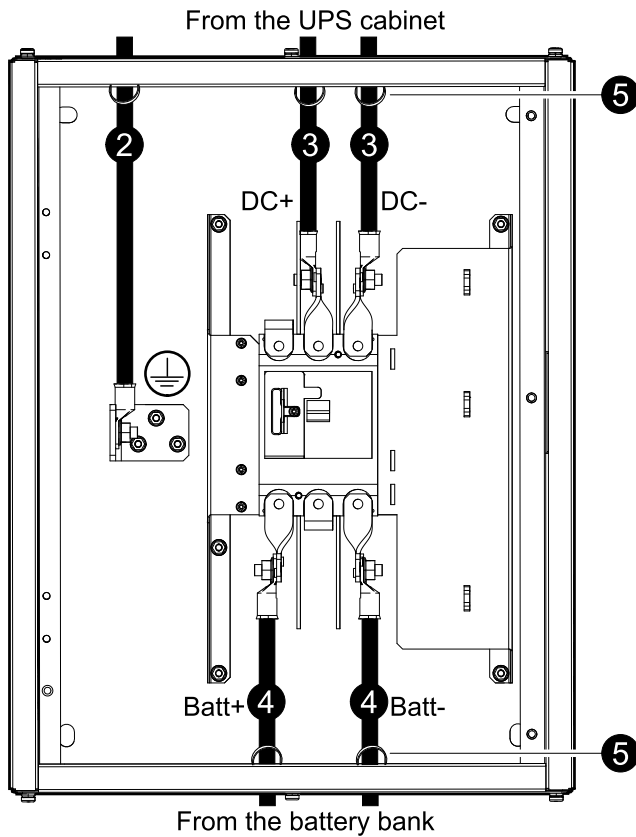

Cables from the UPS Cabinet Routed through the Bottom of the 20–80 kW Battery Breaker Box

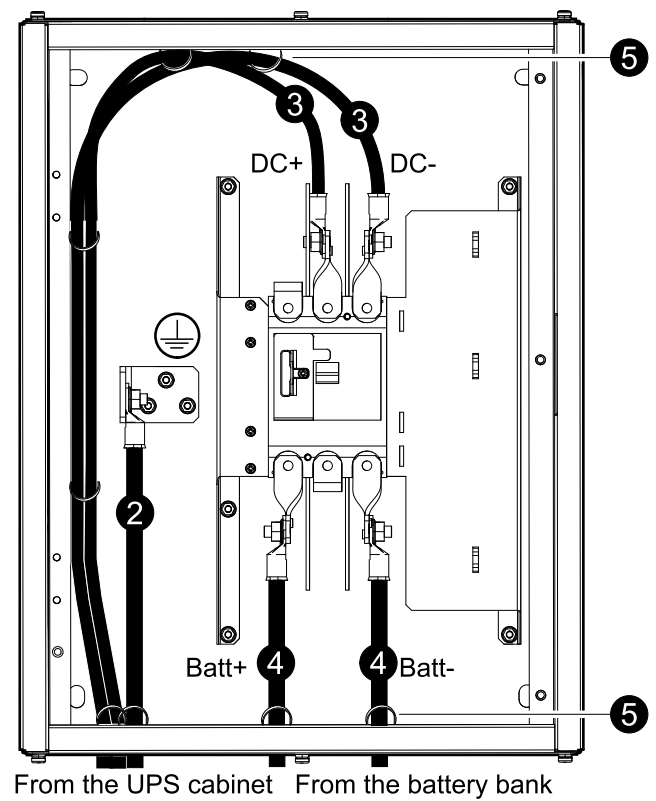

Cables from the UPS Cabinet Routed through the Bottom of the 100–200 kW Battery Breaker Box

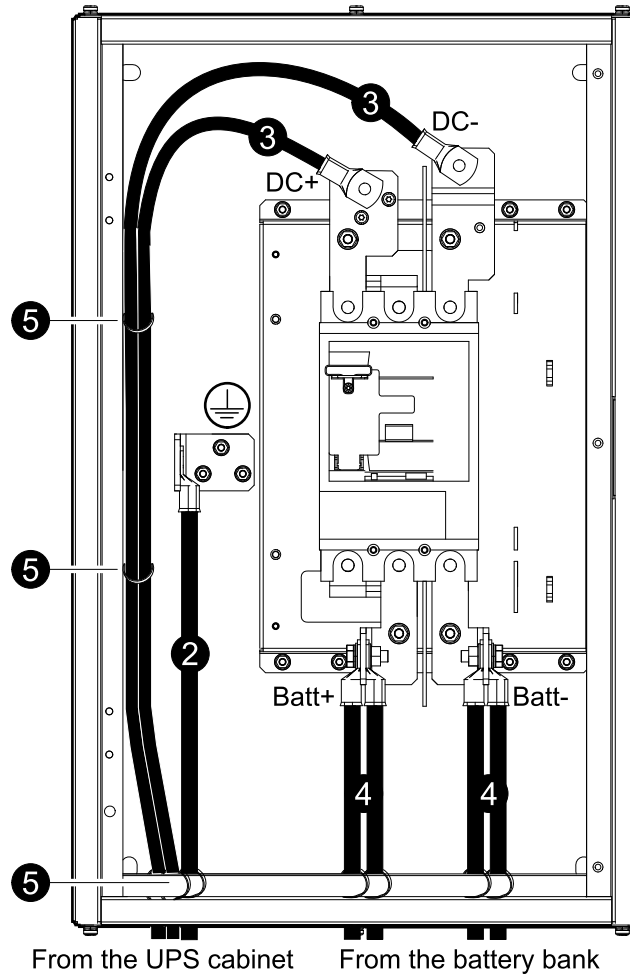

- Route the DC cables from the UPS cabinet through either the top or bottom of the battery breaker box and connect.

⚠ DANGER

HAZARD OF ELECTRIC SHOCK, EXPLOSION, OR ARC FLASH

Reinstall the inner cover in the top of the battery breaker box before continuing with the installation.

Failure to follow these instructions will result in death or serious injury.

- Route the battery cables from the battery bank through the bottom of the battery breaker box and connect.

⚠ DANGER

HAZARD OF ELECTRIC SHOCK, EXPLOSION, OR ARC FLASH

- Reinstall the inner cover in the bottom of the battery breaker box before continuing with the installation.
- Ensure correct polarity.

Failure to follow these instructions will result in death or serious injury.

- Attach the cables to the cables reliefs in the left side, the top, and the bottom of the battery breaker box.

Add Translated Safety Labels to Your Product

The safety labels on your product are in English and French. Sheets of translated replacement safety labels are provided with your product.

1. Locate the 885–XXXX part number on each safety label on your product.
2. Find the matching sheet of replacement safety labels provided with your product — check that the 885–XXXX part numbers match.
3. Add the replacement safety label in your preferred language to your product on top of the existing French safety label.

Final Installation Steps

1. Close the dead front panel and fasten with the three screws.

Front View of the Battery Breaker Box

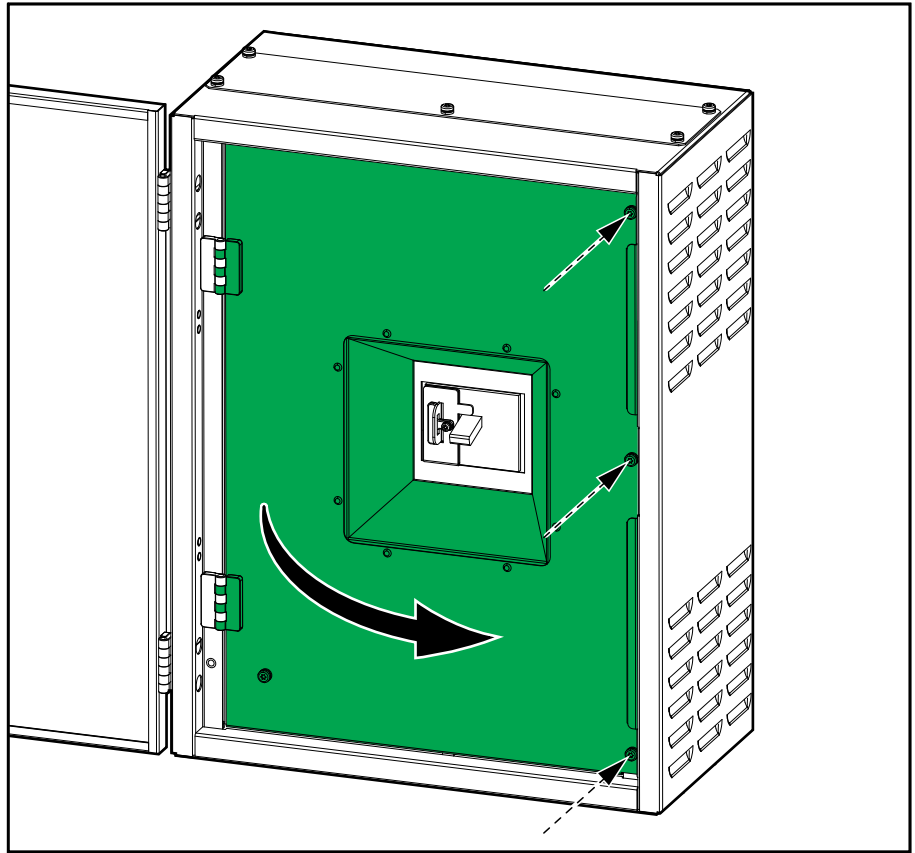

2. Close the front door of the battery breaker box.

Schneider Electric
35 rue Joseph Monier
92500 Rueil Malmaison
France

+ 33 (0) 1 41 29 70 00



As standards, specifications, and design change from time to time,
please ask for confirmation of the information given in this publication.

© 2018 – 2018 Schneider Electric. All rights reserved.

990-5914A-001