

Inspiron 14 5441

Owner's Manual

Notes, cautions, and warnings

 **NOTE:** A NOTE indicates important information that helps you make better use of your product.

 **CAUTION:** A CAUTION indicates either potential damage to hardware or loss of data and tells you how to avoid the problem.

 **WARNING:** A WARNING indicates a potential for property damage, personal injury, or death.

Chapter 1: Views of Inspiron 14 5441.....	6
Front.....	6
Top.....	7
Left.....	8
Right.....	9
Bottom.....	9
Locate the Service Tag or Express Service Code label of your computer.....	10
Battery charge and status light	10
Chapter 2: Set up your Inspiron 14 5441.....	12
Chapter 3: Specifications of Inspiron 14 5441.....	14
Dimensions and weight.....	14
Processor.....	14
Chipset.....	15
Operating system.....	15
Memory.....	16
External ports and slots.....	16
Internal slots.....	16
Wireless module.....	17
Audio.....	17
Storage.....	18
Media-card reader.....	18
Keyboard.....	18
Keyboard function keys.....	19
Camera.....	20
Touchpad.....	21
Power adapter.....	21
Power adapter requirements of Inspiron 14 5441.....	22
Battery.....	23
Display.....	23
Fingerprint reader (optional).....	24
GPU—Integrated.....	24
External display support.....	25
Operating and storage environment.....	25
Dell support policy.....	25
Chapter 4: Working inside your computer.....	26
Safety instructions.....	26
Before working inside your computer.....	26
Safety precautions.....	27
Electrostatic discharge—ESD protection.....	27
ESD Field Service kit	28
Transporting sensitive components.....	29

After working inside your computer.....	29
BitLocker.....	29
Recommended tools.....	29
Screw list.....	29
Major components of Inspiron 14 5441.....	30

Chapter 5: Removing and installing Customer Replaceable Units (CRUs)..... 33

Base cover.....	33
Removing the base cover.....	33
Installing the base cover	36
Fan.....	38
Removing the fan	38
Installing the fan	39
Solid state drive.....	40
Removing the solid state drive	40
Installing the solid state drive	41
Speakers.....	43
Removing the speakers	43
Installing the speakers	45

Chapter 6: Removing and installing Field Replaceable Units (FRUs)..... 47

Battery.....	47
Rechargeable Li-ion battery precautions.....	47
Removing the battery	47
Installing the battery	48
Battery cable.....	49
Disconnecting the battery cable	49
Connecting the battery cable	51
Coin-cell battery.....	52
Removing the coin-cell battery.....	52
Installing the coin-cell battery.....	53
Display assembly.....	54
Removing the display assembly	54
Installing the display assembly	56
Heat sink.....	58
Removing the heat sink.....	58
Installing the heat sink.....	58
Touchpad.....	59
Removing the touchpad.....	59
Installing the touchpad	60
I/O board.....	61
Removing the I/O board	61
Installing the I/O board	62
I/O-board cable	63
Removing the I/O-board cable.....	63
Installing the I/O-board cable.....	65
Power button.....	66
Removing the power button	66
Installing the power button	67

Power button with optional fingerprint reader.....	69
Removing the power button with optional fingerprint reader	69
Installing the power button with optional fingerprint reader	69
Antennas.....	71
Removing the antennas.....	71
Installing the antennas.....	73
System board.....	76
Removing the system board	76
Installing the system board	80
Palm-rest and keyboard assembly.....	83
Removing the palm-rest and keyboard assembly	83
Installing the palm-rest and keyboard assembly	84
Chapter 7: Software.....	86
Operating system.....	86
Drivers and downloads.....	86
Chapter 8: BIOS Setup.....	87
Entering BIOS Setup program.....	87
Navigation keys.....	87
F12 One Time Boot menu.....	87
BIOS Setup options.....	88
Updating the BIOS.....	96
Updating the BIOS in Windows.....	96
Updating the BIOS using the USB drive in Windows.....	97
Updating the BIOS from the One Time Boot menu.....	97
System and setup password.....	98
Assigning a System Setup password.....	98
Deleting or changing an existing system password or setup password.....	98
Clearing CMOS settings.....	99
Clearing BIOS (System Setup) and System passwords.....	99
Clearing chassis intrusion alert.....	99
Chapter 9: Troubleshooting.....	102
Handling swollen rechargeable Li-ion batteries.....	102
Locating the Service Tag or Express Service Code of your Dell computer	102
Dell SupportAssist Pre-boot System Performance Check diagnostics.....	103
Running the SupportAssist Pre-Boot System Performance Check.....	103
Built-in self-test (BIST).....	103
LCD Built-in Self-Test (BIST).....	103
LCD Power rail test (L-BIST).....	104
System-diagnostic lights.....	104
Backup media and recovery options.....	104
Wi-Fi power cycle.....	104
Drain flea power (perform hard reset).....	105
Chapter 10: Getting help and contacting Dell Technologies.....	106

Views of Inspiron 14 5441

Front



Figure 1. Front view

1. **Microphones**

Provides digital sound input for audio recording and voice calls.

2. **Infrared camera**

Enhances security when paired with Windows Hello face authentication.

3. **Infrared camera-status light**

Turns on when the camera is in use.

4. **Privacy shutter**

Slide the privacy shutter to cover the camera lens and protect your privacy when the camera is not in use.

5. **Camera**

Enables you to video chat, capture photos, and record videos.

6. **Camera-status light**

Turns on when the camera is in use.

7. **Ambient-light sensor**

The sensor detects the ambient light and automatically adjusts the keyboard backlight (optional) and display brightness.

Top

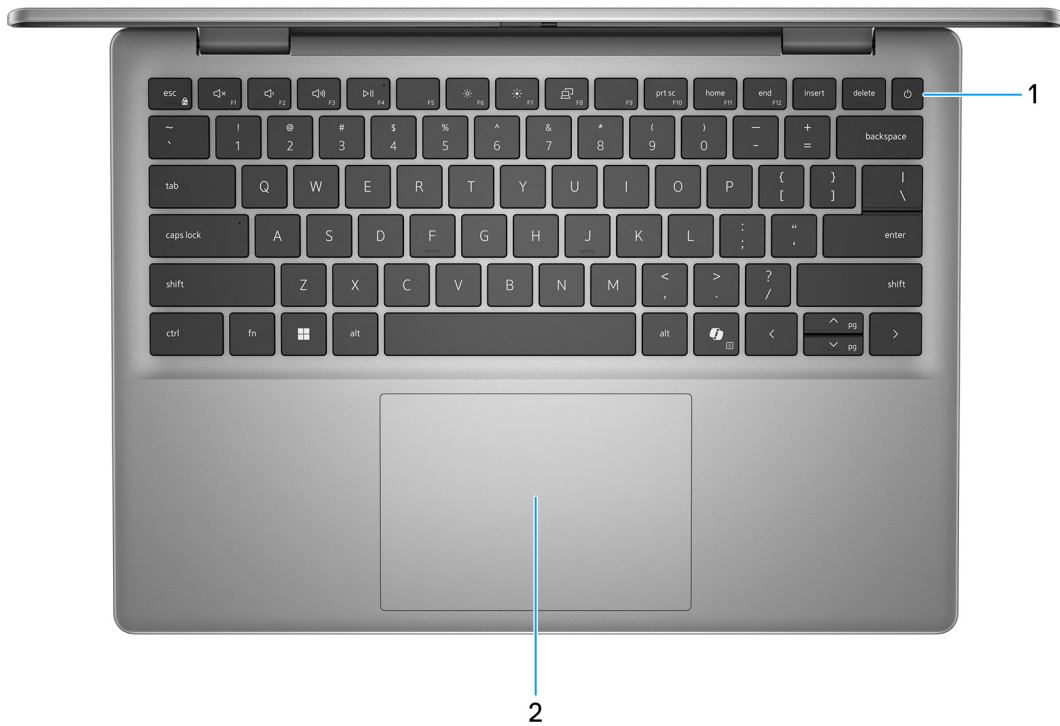

Figure 2. Top view

1. Power button with optional fingerprint reader

Press to turn on the computer if it is turned off, in sleep state, or in hibernation state.

When the computer is turned on, press the power button to put the computer into a sleep state; press and hold the power button for 10 seconds to force shut-down the computer.

If the power button has a fingerprint reader, place your finger on the power button steadily to log in.

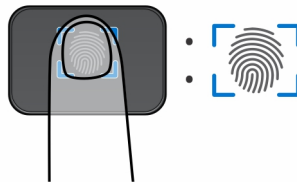

Figure 3. Active area of the fingerprint reader

NOTE: The highlighted area indicates the active fingerprint reader area, and the image is for illustrative purposes only.

NOTE: You can customize the power-button behavior in Windows. For more information, see [Dell Support Site](#).

2. Precision touchpad

Move your finger on the touchpad to move the mouse pointer. Tap to left-click and two fingers tap to right-click.

Left



Figure 4. Left view

1. USB4 40 Gbps USB Type-C port with DisplayPort and Power Delivery

Connect devices such as external storage devices, printers, and external displays. Supports Power Delivery that enables two-way power supply between devices. Supports DisplayPort 1.4a that enables you to connect to an external display using a display adapter. Provides data transfer rates of up to 40 Gbps.

NOTE: You can connect a Dell docking station to one of the two USB Type-C ports. If your docking station has two cables, do not connect both cables to the two USB Type-C ports simultaneously. You may encounter issues with the charging circuits when this method of connection is used. For more information, search in the Knowledge Base Resource at the [Dell Support site](#).

NOTE: A 40 Gbps-certified cable is required to achieve the maximum performance of 40 Gbps.

NOTE: A USB Type-C to DisplayPort adapter (sold separately) is required to connect to a DisplayPort device.

NOTE: The USB4 Type-C port is backward compatible with USB 3.2 and USB 2.0.

2. USB4 40 Gbps USB Type-C port with DisplayPort and Power Delivery

Connect devices such as external storage devices, printers, and external displays. Supports Power Delivery that enables two-way power supply between devices. Supports DisplayPort 1.4a that enables you to connect to an external display using a display adapter. Provides data transfer rates of up to 40 Gbps.

NOTE: You can connect a Dell docking station to one of the two USB Type-C ports. If your docking station has two cables, do not connect both cables to the two USB Type-C ports simultaneously. You may encounter issues with the charging circuits when this method of connection is used. For more information, search in the Knowledge Base Resource at the [Dell Support site](#).

NOTE: A 40 Gbps-certified cable is required to achieve the maximum performance of 40 Gbps.

NOTE: A USB Type-C to DisplayPort adapter (sold separately) is required to connect to a DisplayPort device.

NOTE: The USB4 Type-C port is backward compatible with USB 3.2 and USB 2.0.

3. Battery-status light

Indicates the battery-charge status. When the battery charge is low, the status light shows a solid yellow.

4. microSD-card slot

Reads from and writes to the microSD card. The computer supports the following card types:

- Micro Secure Digital (mSD)
- Micro Secure Digital High Capacity (mSDHC)
- Micro Secure Digital Extended Capacity (mSDXC)

Right



Figure 5. Right view

1. USB 3.2 Gen 1 (5 Gbps) port

Connect devices such as external storage devices and printers. Provides a data transfer rate of up to 5 Gbps.

2. Global headset audio jack

Connect headphones or a headset (headphone and microphone combo).

Bottom

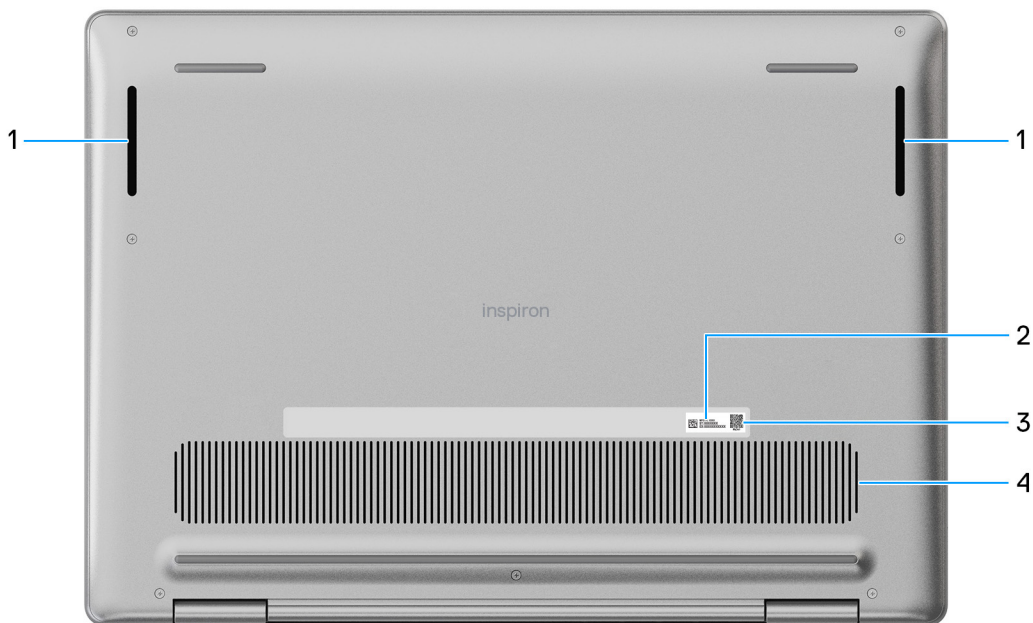

Figure 6. Bottom view

1. Speakers

Provides audio output.

2. Service Tag/Express Service Code label

The Service Tag is a unique alphanumeric identifier that enables Dell service technicians to identify the hardware components in your computer and access warranty information. The Express Service Code is a numeric version of the Service Tag.

3. MyDell QR code

MyDell is your hub for content personalized to your Inspiron 14 5441, including videos, articles, manuals, and easy access to support.

4. Air vents

Air vents provide ventilation for your computer. Clogged air vents can cause overheating and can affect your computer's performance and potentially cause hardware issues. Keep the air vents clear of obstructions and clean them regularly to prevent the build-up of dust and dirt. For more information about cleaning air vents, search for articles in the Knowledge Base Resource at [Dell Support Site](#).

Locate the Service Tag or Express Service Code label of your computer

The service tag is a unique alphanumeric identifier that allows Dell service technicians to identify the hardware components in your computer and access warranty information. The Express Service Code is a numeric version of the Service Tag.

For more information about how to find the Service Tag of your computer, search in the Knowledge Base Resource at the [Dell Support Site](#).

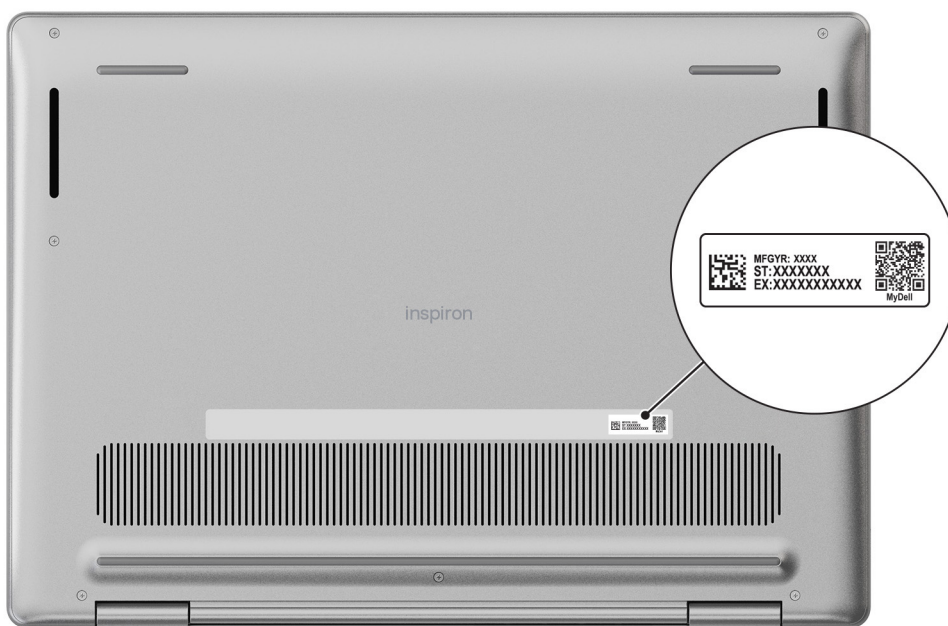

Figure 7. Service Tag/Express Service Code location

Battery charge and status light

The following table lists the battery charge and status light behavior of your computer.

Table 1. Battery charge and status light behavior

Power Source	LED Behavior	System Power State	Battery Charge Level
AC Adapter	Off	S0 - S5	Fully Charged
AC Adapter	Solid White	S0 - S5	< Fully Charged
Battery	Off	S0 - S5	11-100%
Battery	Solid Amber (590+/-3 nm)	S0 - S5	<=10%

- S0 (ON) - The computer is turned on.
- S4 (Hibernate) - The computer consumes the least power compared to all other sleep states. The computer is almost in an OFF state. The context data is written to a storage device so that you can resume everything from where you left, once the computer is turned on.

- S5 (OFF) - The computer is in a shutdown state.

Set up your Inspiron 14 5441

About this task

NOTE: The images in this document may differ from your computer depending on the configuration you ordered.

Steps

1. Connect the power adapter and press the power button.



Figure 8. Connect the power adapter and press the power button.

NOTE: The battery may go into power-saving mode during shipment to conserve charge on the battery. Ensure that the power adapter is connected to your computer when it is turned on for the first time.

2. Finish the operating system setup.

For Windows:

Follow the on-screen instructions to complete the setup. When setting up, it is recommended that you:







- Connect to a network for Windows updates.

NOTE: If connecting to a secured wireless network, enter the password for the wireless network access when prompted.

- If connected to the Internet, sign-in with an existing Microsoft account or create a new account. If not connected to the Internet, create an offline account.
- On the **Support and Protection** screen, enter your contact details.

3. Locate and use Dell apps from the Windows Start menu—Recommended.

Table 2. Locate Dell apps

Resources	Description
	<p>Dell Product Registration Register your computer with Dell.</p>
	<p>Dell Help & Support Access help and support for your computer.</p>
	<p>SupportAssist SupportAssist proactively and predictively identifies hardware and software issues on your computer and automates the engagement process with Dell Technical support. It also addresses performance and stabilization issues, prevents security threats, monitors and detects hardware failures. For more information, see SupportAssist for Home PCs User's Guide at Dell Support Site.  NOTE: In SupportAssist, click the warranty expiry date to renew or upgrade your warranty.</p>
	<p>Dell Update Updates your computer with critical fixes and latest device drivers as they become available. For more information about using Dell Update, see the product guides and third-party license documents at Dell Support Site.</p>
	<p>Dell Digital Delivery Download software applications, which are purchased but not preinstalled on your computer. For more information about using Dell Digital Delivery, search in the Knowledge Base Resource at Dell Support Site.</p>

Specifications of Inspiron 14 5441

Dimensions and weight

The following table lists the height, width, depth, and weight of your Inspiron 14 5441.

Table 3. Dimensions and weight

Description	Values
Height:	
Front height	15.14 mm (0.60 in.)
Rear height	16 mm (0.63 in.)
Maximum height	17.90 mm (0.70 in.)
Width	314 mm (12.36 in.)
Depth	223.75 mm (8.81 in.)
Weight	1.54 kg (3.39 lb)
 NOTE: The weight of your computer depends on the configuration that is ordered and manufacturing variability.	

Processor

The following table lists the details of the processors that are supported for your Inspiron 14 5441.

Table 4. Processor

Description	Option one	Option two	Option three
Processor type	Qualcomm Snapdragon X Plus X1P-42-100	Qualcomm Snapdragon X Plus X1P-64-100	Qualcomm Snapdragon X X1-26-100
Processor wattage	18 W	18 W	18 W
Processor total core count	8	10	8
Performance-cores	8	6	8
Efficient-cores	Not applicable	4	Not applicable
Processor total thread count	8	10	8
Processor speed	Up to 3.42 GHz	Up to 3.40 GHz	Up to 2.97 GHz
Performance-cores frequency			
Processor base frequency	3.24 GHz	3.40 GHz	2.95 GHz
Maximum turbo frequency	3.42 GHz	3.40 GHz	2.97 GHz

Table 4. Processor (continued)

Description	Option one	Option two	Option three
Efficient-cores frequency			
Processor base frequency	Not applicable	3.40 GHz	Not applicable
Maximum turbo frequency	Not applicable	3.40 GHz	Not applicable
Thermal Mode/Thermal Design Power (TDP)			
Cool	13 W	13 W	13 W
Optimized	18 W	18 W	18 W
Quiet	12 W	12 W	12 W
Ultra Performance	21 W	21 W	21 W
 NOTE: Processor clock speeds and thermal design power differ according to the thermal mode selected in the MyDell app on your computer.			
Processor cache	30 MB	42 MB	30 MB
Neural Processing Unit (performance)	Up to 45 TOPS	Up to 45 TOPS	Up to 45 TOPS
Integrated graphics	Qualcomm Adreno	Qualcomm Adreno	Qualcomm Adreno

Chipset

The following table lists the details of the chipset that is supported by your Inspiron 14 5441.

Table 5. Chipset

Description	Values
Chipset	Integrated with the processor
Processor	<ul style="list-style-type: none"> Qualcomm Snapdragon X Qualcomm Snapdragon X Plus
DRAM bus width	128-bit
Flash EPROM	64 MB
PCIe bus	Up to PCIe 4.0

Operating system

Your Inspiron 14 5441 supports the following operating systems:

- Win 11 Home, ARM
- Win 11 Pro, ARM

Memory

The following table lists the memory specifications of your Inspiron 14 5441.

Table 6. Memory specifications

Description	Values
Memory slots	Onboard
Memory type	LPDDR5x
Memory speed	8448 MT/s
Maximum memory configuration	32 GB
Minimum memory configuration	16 GB
Memory configurations supported	<ul style="list-style-type: none">• 16 GB: LPDDR5x, 8448 MT/s (onboard)• 32 GB: LPDDR5x, 8448 MT/s (onboard)

External ports and slots

The following table lists the external ports and slots on your Inspiron 14 5441.

Table 7. External ports and slots

Description	Values
USB ports	<ul style="list-style-type: none">• One USB 3.2 Gen 1 (5 Gbps) port• Two USB4 40 Gbps USB Type-C port with DisplayPort and Power Delivery)
Audio port	One headset (headphone and microphone combo) port
Video port(s)	Not applicable
Media-card reader	One microSD-card slot
Power-adaptor port	Not applicable
Security-cable slot	Not applicable

Internal slots

The following table lists the internal slots of your Inspiron 14 5441.

Table 8. Internal slots

Description	Values
M.2	One M.2 2230 slot for solid state drive  NOTE: To learn more about the features of different types of M.2 cards, search in the Knowledge Base Resource at Dell Support Site .

Wireless module

The following table lists the Wireless Local Area Network (WLAN) module that is supported on your Inspiron 14 5441.

Table 9. Wireless module specifications

Description	Values
Model number	Qualcomm FastConnect 7800 DBS (onboard)
Transfer rate	Up to 5760 Mbps
Frequency bands supported	2.4 GHz/5 GHz/6 GHz
Wireless standards	<ul style="list-style-type: none"> • WiFi 802.11a/b/g • Wi-Fi 4 (WiFi 802.11n) • Wi-Fi 5 (WiFi 802.11ac) • Wi-Fi 6E (WiFi 802.11ax) • Wi-Fi 7 (WiFi 802.11be)
Encryption	<ul style="list-style-type: none"> • 64-bit/128-bit WEP • AES-CCMP • TKIP
Bluetooth wireless card	Bluetooth 5.4

Audio

The following table lists the audio specifications of your Inspiron 14 5441.

Table 10. Audio specifications

Description	Values	
Audio controller	Qualcomm WCD9385	
Stereo conversion	Supported	
Internal audio interface	SoundWire	
External audio interface	Global headset audio jack	
Number of speakers	2	
Internal-speaker amplifier	Supported	
External volume controls	Keyboard shortcut controls	
Speaker output:		
	Average	2 W x 2
	Peak	2.5 W x 2
Microphone	Dual-array microphones	

Storage

This section lists the storage options on your Inspiron 14 5441.
Your computer supports only one M.2 2230 solid-state drive.

Table 11. Storage specifications

Storage type	Interface type	Capacity
One M.2 2230 solid state drive	PCIe NVMe 4x4	Up to 1 TB

Media-card reader

The following table provides the specification of media cards that are supported by your Inspiron 14 5441.

Table 12. Media-card reader specifications

Description	Values
Media-card slot type	One microSD-card slot
Media-cards supported	<ul style="list-style-type: none">• Micro Secure Digital (mSD)• Micro Secure Digital High Capacity (mSDHC)• Micro Secure Digital Extended Capacity (mSDXC)
 NOTE: The maximum capacity that is supported by the media-card reader varies depending on the standard of the media card that is installed on your computer.	



Keyboard

The following table lists the keyboard specifications of your Inspiron 14 5441.

Table 13. Keyboard specifications

Description	Values
Keyboard type	<ul style="list-style-type: none">• Backlit keyboard with Copilot key• Non-backlit keyboard with Copilot key
Keyboard layout	QWERTY
Number of keys	<ul style="list-style-type: none">• Arabic, English International, English US, Canadian Bilingual, Hebrew: 79 keys• Belgian, English UK, French European, German, Hungarian, Italian, Spanish, Swiss European: 80 keys• Japanese: 83 keys• Brazilian: 81 keys
Keyboard size	X=19.05 mm key pitch Y=18.05 mm key pitch
Keyboard shortcuts	Some keys on your keyboard have two symbols on them. These keys can be used to type alternate characters or to perform secondary functions. To type the alternate character, press Shift and the required key. To perform secondary functions, press Fn and the desired key.

Table 13. Keyboard specifications (continued)

Description	Values
	<p> NOTE: You can define the primary behavior of the function keys (F1–F12) changing Fn Lock Options in BIOS setup program. For more information, see Keyboard function keys.</p> <p> NOTE: If Copilot in Windows is not available on your computer, the Copilot key launches Recall. If both Recall and Copilot in Windows are not available on your computer, the Copilot key launches Windows Search. For more information about Copilot in Windows and Recall, search in the Knowledge Base Resource at the Dell Support Site.</p>

Keyboard function keys

 **NOTE:** Keyboard characters may differ depending on the keyboard language configuration. Keys that are used for shortcuts remain the same across all language configurations.

Some keys on your keyboard have two symbols on them. These keys can be used to type alternate characters or to perform secondary functions. The symbol that is shown on the lower part of the key refers to the character that is typed out when the key is pressed. If you press shift and the key, the symbol that is shown on the upper part of the key is typed out. For example, if you press 2, **2** is typed out; if you press Shift + 2, **@** is typed out.

The keys F1-F12 at the top row of the keyboard are function keys for multimedia control, as indicated by the icon on the key. Press the function key to invoke the task represented by the icon. For example, pressing F1 mutes the audio (see the table below).

However, if the function keys F1-F12 are needed for specific software applications, multimedia functionality can be disabled by pressing Fn + Esc. Later, multimedia control can be invoked by pressing fn and the respective function key. For example, mute audio by pressing fn + F1.

Table 14. Primary behavior of function keys

Function key	Primary behavior
F1	Mute/unmute audio
F2	Decrease audio volume
F3	Increase audio volume
F4	Play or pause media file
F5	Turn on or turn off keyboard backlight (optional)
F6	Decrease display brightness
F7	Increase display brightness
F8	Switch to an external display
F10	Print screen (screen capture)
F11	Move cursor to the beginning of the line
F12	Move cursor to the end of the line
Copilot	<p>Launch Copilot in Windows</p> <p> NOTE: If Copilot in Windows is not available on your computer, the Copilot key launches Recall. If both Recall and Copilot in Windows are not available on your computer, the Copilot key launches Windows Search.</p>

Table 14. Primary behavior of function keys (continued)

Function key	Primary behavior
	For more information about Copilot in Windows and Recall, search in the Knowledge Base Resource at the Dell Support Site .

The **fn** key is also used with selected keys on the keyboard to invoke other secondary functions.

Table 15. Secondary behavior

Function key	Secondary behavior
fn + F1	Operating system and application-specific F1 behavior
fn + F2	Operating system and application-specific F2 behavior
fn + F3	Operating system and application-specific F3 behavior
fn + F4	Operating system and application-specific F4 behavior
fn + F5	Operating system and application-specific F5 behavior (optional)
fn + F6	Operating system and application-specific F6 behavior
fn + F8	Operating system and application-specific F8 behavior
fn + F9	Operating system and application-specific F9 behavior
fn + F10	Operating system and application-specific F10 behavior
fn + F11	Operating system and application-specific F11 behavior
fn + F12	Operating system and application-specific F12 behavior
fn + B	Pause or Break
fn + S	Toggle scroll lock
fn + R	System request
fn + Copilot	Open the application menu
fn + Esc	Toggles the function key on and off
fn + PgUp	Scroll up the document or page
fn + PgDn	Scroll down the document or page
fn + left arrow	Home (move to the beginning of the document)
fn + right arrow	End (move to the end of the document)

Camera

The following table lists the camera specifications of your Inspiron 14 5441.

Table 16. Camera specifications

Description	Values
Number of cameras	Two
Camera type	FHD Infrared camera with Ambient Light Sensor (ALS)
Camera location	Front
Camera sensor type	CMOS sensor technology

Table 16. Camera specifications (continued)

Description		Values
Camera resolution:		
	Still image	2.07 megapixel
	Video	1920 x 1080 (FHD) at 30 fps
Infrared camera resolution:		
	Still image	0.92 megapixel
	Video	1280 x 720 (HD) at 30 fps
Diagonal viewing angle:		
	Camera	80.2 degrees
	Infrared camera	86.6 degrees

Touchpad

The following table lists the touchpad specifications of your Inspiron 14 5441.

Table 17. Touchpad specifications

Description		Values
Touchpad resolution:		>300 DPI
Touchpad dimensions:		
	Horizontal	115 mm (4.53 in.)
	Vertical	80 mm (3.15 in.)
Touchpad gestures		For more information about the touchpad gestures available on Windows, see the Microsoft Knowledge Base article at Microsoft Support Site .

Power adapter

The following table lists the power adapter specifications of your Inspiron 14 5441.

Table 18. Power-adapter specifications

Description		Values
Type		65 W
Power-adapter dimensions:		
	Height	28 mm (1.10 in.)
	Width	51 mm (2.01 in.)
	Depth	112 mm (4.41 in.)
Input voltage		100 VAC–240 VAC

Table 18. Power-adapter specifications (continued)





Description		Values
Input frequency		50 Hz–60 Hz
Input current (maximum)		1.70 A
Output current (continuous)		<ul style="list-style-type: none"> • 20 V/3.25 A • 15 V/3 A • 9 V/3 A • 5 V/3 A
Rated output voltage		<ul style="list-style-type: none"> • 20 VDC • 15 VDC • 9 VDC • 5 VDC
Temperature range:		
	Operating	0°C to 40°C (32 °F–104°F)
	Storage	40 °C–70°C (40 °F–158°F)
 CAUTION: Operating and storage temperature ranges may differ among components, so operating or storing the device outside these ranges may impact the performance of specific components.		

Power adapter requirements of Inspiron 14 5441

 **NOTE:** If you did not purchase the Dell-branded power adapter that is recommended for your computer, ensure that the power adapter you use meets the following requirements.

The following table lists the power adapter requirements for your Inspiron 14 5441.



Table 19. Power adapter requirements

Description	Value
Power that is required from a power adapter to achieve optimal performance.	65 W
Power that charges the computer at a slower speed.  NOTE: A warning message may appear informing you about the use of a lower-powered adapter and slower charging speed.	Less than 60 W
Minimum power that is required from a power adapter to operate the computer and charge the battery.  NOTE: A warning message appears informing you about the use of a lower-powered adapter and slower charging speed.	27 W
USB Power Delivery (PD) fast charging.	Supported
ExpressCharge mode	Supported  NOTE: Ensure that the computer is connected to a 65 W power adapter for this feature to be supported.  NOTE: ExpressCharge mode must also be enabled in the BIOS Setup screen. Select Power > Battery Configuration > ExpressCharge , then press Enter .

Battery

The following table lists the battery specifications of your Inspiron 14 5441.

Table 20. Battery specifications

Description		Values
Battery type		3-cell, 54 Wh, lithium-ion, Long Cycle Life + ExpressCharge
Battery voltage		11.4 VDC
Battery weight (maximum)		0.22 kg (0.49 lb)
Battery dimensions:		
	Height	5.73 mm (0.23 in.)
	Width	263 mm (10.35 in.)
	Depth	68.90 mm (2.71 in.)
Temperature range:		
	Operating	<ul style="list-style-type: none"> • Charge: 0 °C–45 °C (32 °F–113 °F) • Discharge: 0 °C–70 °C (32 °F–158 °F)
	Storage	–20 °C–65 °C (4 °F–149 °F)
Battery operating time		Varies depending on operating conditions and can significantly reduce under certain power-intensive conditions.
Battery charging time (approximate)		<ul style="list-style-type: none"> • 3 hours (Standard charge) • 2 hours (ExpressCharge)
Coin-cell battery		CR2032
<p> CAUTION: Operating and storage temperature ranges may differ among components, so operating or storing the device outside these ranges may impact the performance of specific components.</p> <p> CAUTION: Dell Technologies recommends that you charge the battery regularly for optimal power consumption.</p>		

Display

The following table lists the display specifications of your Inspiron 14 5441.

Table 21. Display specifications

Description		Values
Display type		14", Full High Definition Plus (FHD+)
Touch options		No
Display-panel technology		Wide Viewing Angle (WVA)
Display-panel dimensions (active area):		
	Height	188.49 mm (7.42 in.)

Table 21. Display specifications (continued)

Description		Values
	Width	301.59 mm (11.87 in.)
	Diagonal	355.65 mm (14 in.)
Display-panel native resolution		1920 x 1200
Luminance (typical)		300 nits
Megapixels		2.3
Color gamut		45% NTSC
Pixels Per Inch (PPI)		162
Contrast ratio (minimum)		600:1
Response time (maximum)		35 millisecond
Refresh rate		60/48 Hz
Horizontal view angle		85 +/- degrees
Vertical view angle		85+/- degrees
Pixel pitch		0.1178 mm
Power consumption (maximum)		3.68 W
Anti-glare vs glossy finish		Anti-glare

Fingerprint reader (optional)

The following table lists the specifications of the optional fingerprint-reader of your Inspiron 14 5441.

Table 22. Fingerprint reader specifications

Description	Values
Sensor technology	Capacitive
Sensor resolution	500 ppi
Sensor pixel size	108 x 88

GPU—Integrated

The following table lists the specifications of the integrated Graphics Processing Unit (GPU) supported by your Inspiron 14 5441.

Table 23. GPU—Integrated

Controller	Memory size	Processor
Qualcomm Adreno Graphics	Shared system memory	<ul style="list-style-type: none"> Qualcomm Snapdragon X X1-26-100 Qualcomm Snapdragon X Plus X1P-42-100

Table 23. GPU—Integrated

Controller	Memory size	Processor
		<ul style="list-style-type: none">Qualcomm Snapdragon X Plus X1P-64-100

External display support

The following table lists the external display support for your Inspiron 14 5441.

Table 24. External display support

Graphics card	Supported external displays with laptop display enabled	Supported external displays with laptop display disabled
Qualcomm Adreno Graphics (iGPU only)	3	3

Operating and storage environment

This table lists the operating and storage specifications of your Inspiron 14 5441.

Airborne contaminant level: G1 as defined by ISA-S71.04-1985

Table 25. Computer environment

Description	Operating	Storage
Temperature range	0 °C–35°C (32 °F–95°F)	–30 °C–65°C (–22 °F–149°F)
Relative humidity (maximum)	10% to 90% (non-condensing)	0% to 95% (non-condensing)
Vibration (maximum)*	0.66 GRMS	1.30 GRMS
Shock (maximum)	110 G†	160 G†
Altitude range	–15.2 m to 3048 m (–49.87 ft to 10,000 ft)	–15.2 m to 10,668 m (–49.87 ft to 35,000 ft)
 CAUTION: Operating and storage temperature ranges may differ among components, so operating or storing the device outside these ranges may impact the performance of specific components.		

* Measured using a random vibration spectrum that simulates the user environment.

† Measured using a 2 ms half-sine pulse.









Dell support policy

For information about Dell support policy, search in the Knowledge Base Resource at [Dell Support Site](#).

Working inside your computer

Safety instructions

Use the following safety guidelines to protect your computer from potential damage and to ensure your personal safety. Unless otherwise noted, each procedure in this document assumes that you have read the safety information that shipped with your computer.



-  **WARNING:** Before working inside your computer, read the safety information that is shipped with your computer. For more safety best practices, see [Dell Regulatory Compliance Home Page](#).
-  **WARNING:** Disconnect your computer from all power sources before opening the computer cover or panels. After you finish working inside the computer, replace all covers, panels, and screws before connecting your computer to an electrical outlet.
-  **CAUTION:** To avoid damaging the computer, ensure that the work surface is flat, dry, and clean.
-  **CAUTION:** You should only perform troubleshooting and repairs as authorized or directed by the Dell technical support team. Damage due to servicing that is not authorized by Dell is not covered by your warranty. See the safety instructions that is shipped with the product or at [Dell Regulatory Compliance Home Page](#).
-  **CAUTION:** Before touching anything inside your computer, ground yourself by touching an unpainted metal surface, such as the metal at the back of the computer. While you work, periodically touch an unpainted metal surface to dissipate static electricity which could harm internal components.
-  **CAUTION:** To avoid damaging the components and cards, handle them by their edges, and avoid touching the pins and the contacts.
-  **CAUTION:** When you disconnect a cable, pull it by its connector or its pull tab, not the cable itself. Some cables have connectors with locking tabs or thumbscrews that you must disengage before disconnecting the cable. When disconnecting cables, keep them evenly aligned to avoid bending the connector pins. When connecting cables, ensure that the connector on the cable is correctly oriented and aligned with the port.
-  **CAUTION:** Press and eject any installed card from the media-card reader.
-  **CAUTION:** Exercise caution when handling rechargeable Li-ion batteries in laptops. Swollen batteries should not be used and should be replaced and disposed properly.

Before working inside your computer

About this task

 **NOTE:** The images in this document may differ from your computer depending on the configuration you ordered.

Steps

1. Save and close all open files and exit all open applications.
2. Shut down your computer. For Windows operating system, click **Start** >  **Power** > **Shut down**.
 -  **NOTE:** If you are using a different operating system, see the documentation of your operating system for shut-down instructions.
3. Turn off all the attached peripherals.
4. Disconnect your computer and all attached devices from their electrical outlets.

5. Disconnect all attached network devices and peripherals, such as keyboard, mouse, and monitor from your computer.

 **CAUTION: To disconnect a network cable, unplug the cable from your computer.**

6. Remove any media card and optical disc from your computer, if applicable.

Safety precautions

This section details the primary steps to be followed before performing any disassembly instructions.

Observe the following safety precautions before you perform any installation or break-fix procedures involving disassembly or reassembly:

- Turn off the computer and all attached peripherals.
- Disconnect the computer from AC power.
- Disconnect all network cables and peripherals from the computer.
- Use an ESD field service kit when working inside any to avoid electrostatic discharge (ESD) damage.
- Place the removed component on an anti-static mat after removing it from the computer.
- Wear shoes with nonconductive rubber soles to reduce the chance of getting electrocuted.
- Unplugging, pressing, and holding the power button for 15 seconds should discharge residual power in the system board.

Standby power

Dell products with standby power must be unplugged before you open the back cover. Systems that are equipped with standby power are powered while turned off. The internal power enables the computer to be remotely turned on (Wake-on-LAN) and suspended into a sleep mode and has other advanced power management features.

Bonding

Bonding is a method for connecting two or more grounding conductors to the same electrical potential. This is done by using a field service electrostatic discharge (ESD) kit. When connecting a bonding wire, ensure that it is connected to bare metal and never to a painted or nonmetal surface. Ensure that the wrist strap is secure and in full contact with your skin. Remove all jewelry, watches, bracelets, or rings before grounding yourself and the equipment.

Electrostatic discharge—ESD protection

ESD is a major concern when you handle electronic components, especially sensitive components such as expansion cards, processors, memory modules, and system boards. A slight charge can damage circuits in ways that may not be obvious, such as intermittent problems or a shortened product life span. As the industry pushes for lower power requirements and increased density, ESD protection is an increasing concern.

Due to the increased density of semiconductors used in recent Dell products, the sensitivity to static damage is now higher than in previous Dell products. For this reason, some previously approved methods of handling parts are no longer applicable.

Two recognized types of ESD damage are catastrophic and intermittent failures.

- **Catastrophic** – Catastrophic failures represent approximately 20 percent of ESD-related failures. The damage causes an immediate and complete loss of device functionality. An example of catastrophic failure is a memory module that has received a static shock and immediately generates a "No POST/No Video" symptom with a beep code that is emitted for missing or nonfunctional memory.
- **Intermittent** – Intermittent failures represent approximately 80 percent of ESD-related failures. The high rate of intermittent failures means that most of the time when damage occurs, it is not immediately recognizable. The memory module receives a static shock, but the tracing is merely weakened and does not immediately produce outward symptoms that are related to the damage. The weakened trace may take weeks or months to melt, and in the meantime may cause degradation of memory integrity, intermittent memory errors, and so on.

Intermittent failures that are also called latent or "walking wounded" are difficult to detect and troubleshoot.

Perform the following steps to prevent ESD damage:

- Use a wired ESD wrist strap that is properly grounded. Wireless anti-static straps do not provide adequate protection. Touching the chassis before handling parts does not ensure adequate ESD protection on parts with increased sensitivity to ESD damage.

- Handle all static-sensitive components in a static-safe area. If possible, use anti-static floor pads and workbench pads.
- When unpacking a static-sensitive component from its shipping carton, do not remove the component from the anti-static packing material until you are ready to install the component. Before unwrapping the anti-static packaging, use the anti-static wrist strap to discharge the static electricity from your body. For more information about the wrist strap and ESD wrist strap tester, see [Components of an ESD Field Service Kit](#).
- Before transporting a static-sensitive component, place it in an anti-static container or packaging.

ESD Field Service kit

The unmonitored field service kit is the most commonly used service kit. Each Field Service kit includes three main components: anti-static mat, wrist strap, and bonding wire.

 **CAUTION: It is critical to keep ESD-sensitive devices away from internal parts that are insulated and often highly charged, such as plastic heat sink casings.**

Working Environment

Before deploying the ESD Field Service kit, assess the situation at the customer location. For example, deploying the kit for a server environment is different than for a desktop or laptop environment. Servers are typically installed in a rack within a data center; desktops or laptops are typically placed on office desks or cubicles. Always look for a large open flat work area that is free of clutter and large enough to deploy the ESD kit with additional space to accommodate the type of computer that is being repaired. The workspace should also be free of insulators that can cause an ESD event. On the work area, insulators such as styrofoam and other plastics should always be moved at least 12 inches or 30 centimeters away from sensitive parts before physically handling any hardware components.

ESD Packaging

All ESD-sensitive devices must be shipped and received in static-safe packaging. Metal, static-shielded bags are preferred. However, you should always return the damaged component using the same ESD bag and packaging that the new part arrived in. The ESD bag should be folded over and taped shut and all the same foam packing material should be used in the original box that the new part arrived in. ESD-sensitive devices should be removed from packaging only at an ESD-protected work surface, and parts should never be placed on top of the ESD bag because only the inside of the bag is shielded. Always place parts in your hand, on the anti-static mat, in the computer, or inside an ESD bag.

Components of an ESD Field Service kit

The components of an ESD Field Service kit are:

- **Anti-Static Mat** – The anti-static mat is dissipative and parts can be placed on it during service procedures. When using an anti-static mat, your wrist strap should be snug and the bonding wire should be connected to the anti-static mat and to any bare metal on the computer being worked on. Once deployed properly, service parts can be removed from the ESD bag and placed directly on the anti-static mat. ESD-sensitive items are safe in your hand, on the anti-static mat, in the computer, or inside an ESD bag.
- **Wrist Strap and Bonding Wire** – The wrist strap and bonding wire can be either directly connected between your wrist and bare metal on the hardware if the anti-static mat is not required, or connect to the anti-static mat to protect hardware that is temporarily placed on the mat. The physical connection of the wrist strap and bonding wire between your skin, the anti-static mat, and the hardware is known as bonding. Use only Field Service kits with a wrist strap, anti-static mat, and bonding wire. Never use wireless wrist straps. Always be cautious that the internal wires of a wrist strap are prone to damage from normal wear and tear, and must be checked regularly with a wrist strap tester in order to avoid accidental ESD hardware damage. It is recommended to test the wrist strap and bonding wire at least once per week.
- **ESD Wrist Strap Tester** – The wires inside an ESD strap are prone to damage over time. When using an unmonitored kit, it is a best practice to regularly test the strap prior to each service, and at a minimum, test once per week. A wrist strap tester is the best method for doing this test. To perform the test, plug the bonding-wire of the wrist-strap into the tester while it is strapped to your wrist and push the button to test. A green LED is lit if the test is successful; a red LED is lit and an alarm sounds if the test fails.

 **NOTE:** It is recommended to always use the traditional wired ESD grounding wrist strap and protective anti-static mat when servicing Dell products. In addition, it is critical to keep sensitive parts separate from all insulator parts while servicing the computer.

Transporting sensitive components

When transporting ESD sensitive components such as replacement parts or parts to be returned to Dell, it is critical to place these parts in anti-static bags for safe transport.

After working inside your computer

About this task

CAUTION: Leaving stray or loose screws inside your computer may severely damage your computer.

Steps

1. Replace all screws and ensure that no stray screws remain inside your computer.
2. Connect any external devices, peripherals, or cables you removed before working on your computer.
3. Replace any media cards, discs, or any other components that you removed before working on your computer.
4. Connect your computer and all attached devices to their electrical outlets.
5. Turn on your computer.

BitLocker

CAUTION: If BitLocker is not suspended before updating the BIOS, the BitLocker key is not recognized the next time you reboot the computer. You will then be prompted to enter the recovery key to progress, and the system displays a prompt for the recovery key on each reboot. If the recovery key is not known, this can result in data loss or an operating system reinstall. For more information, see Knowledge Article: [updating the BIOS on Dell systems with BitLocker enabled](#).

The installation of the following components triggers BitLocker:

- Hard disk drive or solid-state drive
- System board

Recommended tools

The procedures in this document may require the following tools:

Phillips screwdriver #0

Screw list

- NOTE:** When removing screws from a component, it is recommended to note the screw type and the quantity of screws, and then place them in a screw storage box. This is to ensure that the correct number of screws and correct screw type is restored when the component is replaced.
- NOTE:** Some computers have magnetic surfaces. Ensure that the screws are not left attached to such surfaces when replacing a component.
- NOTE:** Screw color may vary depending on the configuration ordered.

Table 26. Screw list













Component	Screw type	Quantity	Screw image
Base cover	M2x7.9 captive	2	

Table 26. Screw list (continued)

Component	Screw type	Quantity	Screw image
Base cover	M2x5.5	5	
Battery	M2x4.5 captive	5	
Fan	M2x2.5	3	
Solid state drive	M2x2.5	1	
Display hinges	M2.5x4.5	4	
I/O board	M2x2.5	2	
Heat sink	M2x2.5	4	
Wireless card thermal plate	M2x2.5	1	
Antennas	M2x2.5	1	
USB Type-C bracket	M2x2.5	3	
System board	M1.6x1.8	2	
Touchpad	M1.6x1.8	9	

Major components of Inspiron 14 5441

The following image shows the major components of Inspiron 14 5441.

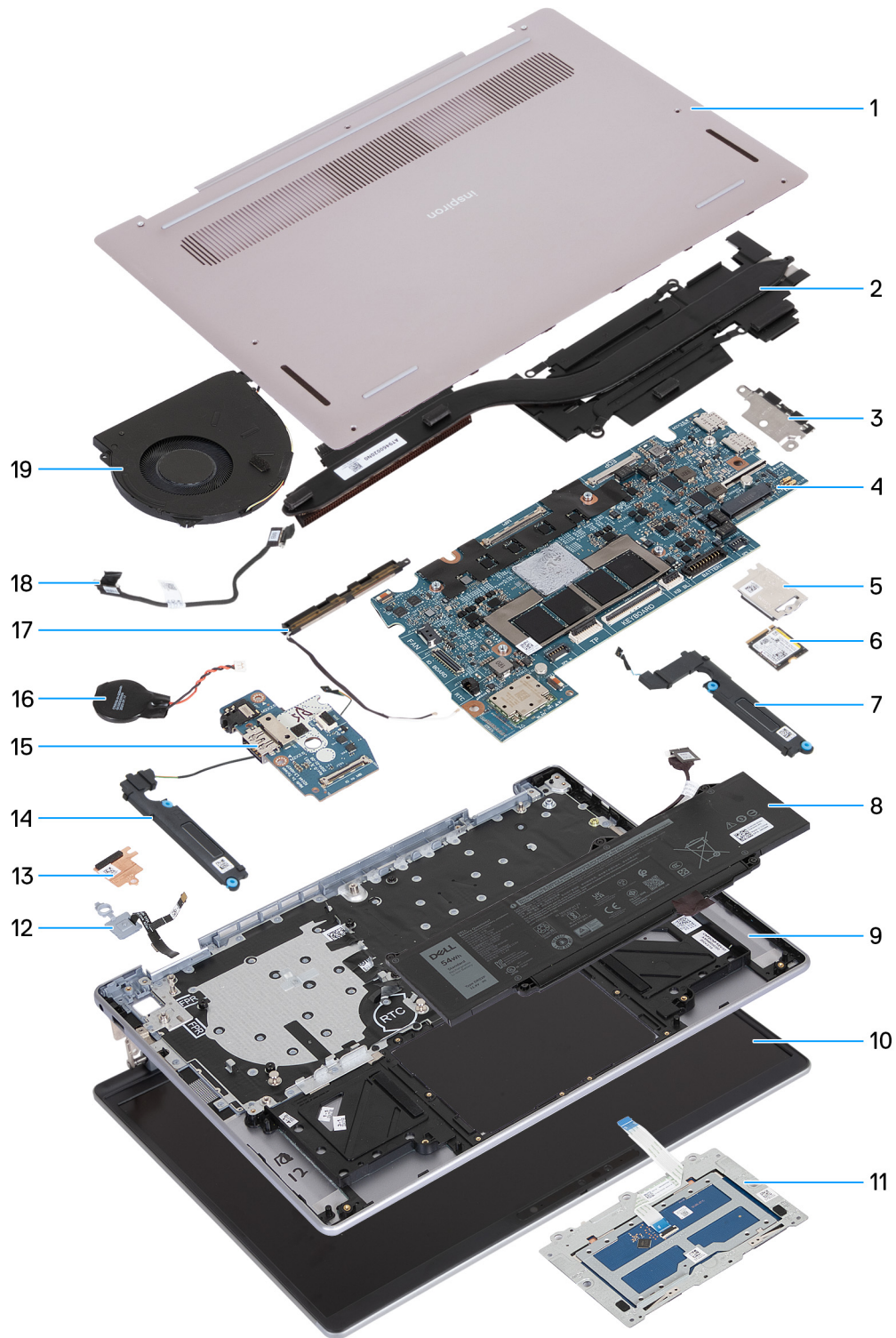



Figure 9. Major components

1. Base cover
2. Heat sink
3. USB Type-C bracket
4. System board
5. Solid state drive thermal shield
6. Solid state drive
7. Left speaker

8. Battery
9. Palm-rest and keyboard assembly
10. Display assembly
11. Touchpad
12. Power button with optional fingerprint reader cable
13. Wireless card thermal plate
14. Right speaker
15. I/O board
16. Coin-cell battery
17. Antennas
18. I/O-board cable
19. Fan

 **NOTE:** Dell provides a list of components and their part numbers for the original computer configuration purchased. These parts are available according to warranty coverage purchased by the customer. Contact your Dell sales representative for purchase options.

Removing and installing Customer Replaceable Units (CRUs)

The replaceable components in this chapter are Customer Replaceable Units (CRUs).

 **CAUTION:** Customers can replace only the Customer Replaceable Units (CRUs) following the safety precautions and replacement procedures.

 **NOTE:** The images in this document may differ from your computer depending on the configuration you ordered.

Base cover

Removing the base cover

Prerequisites

1. Follow the procedure in [Before working inside your computer](#).

About this task

The following images indicate the location of the base cover and provide a visual representation of the removal procedure.

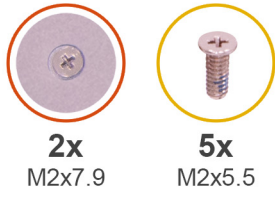

Figure 10. Removing the screws

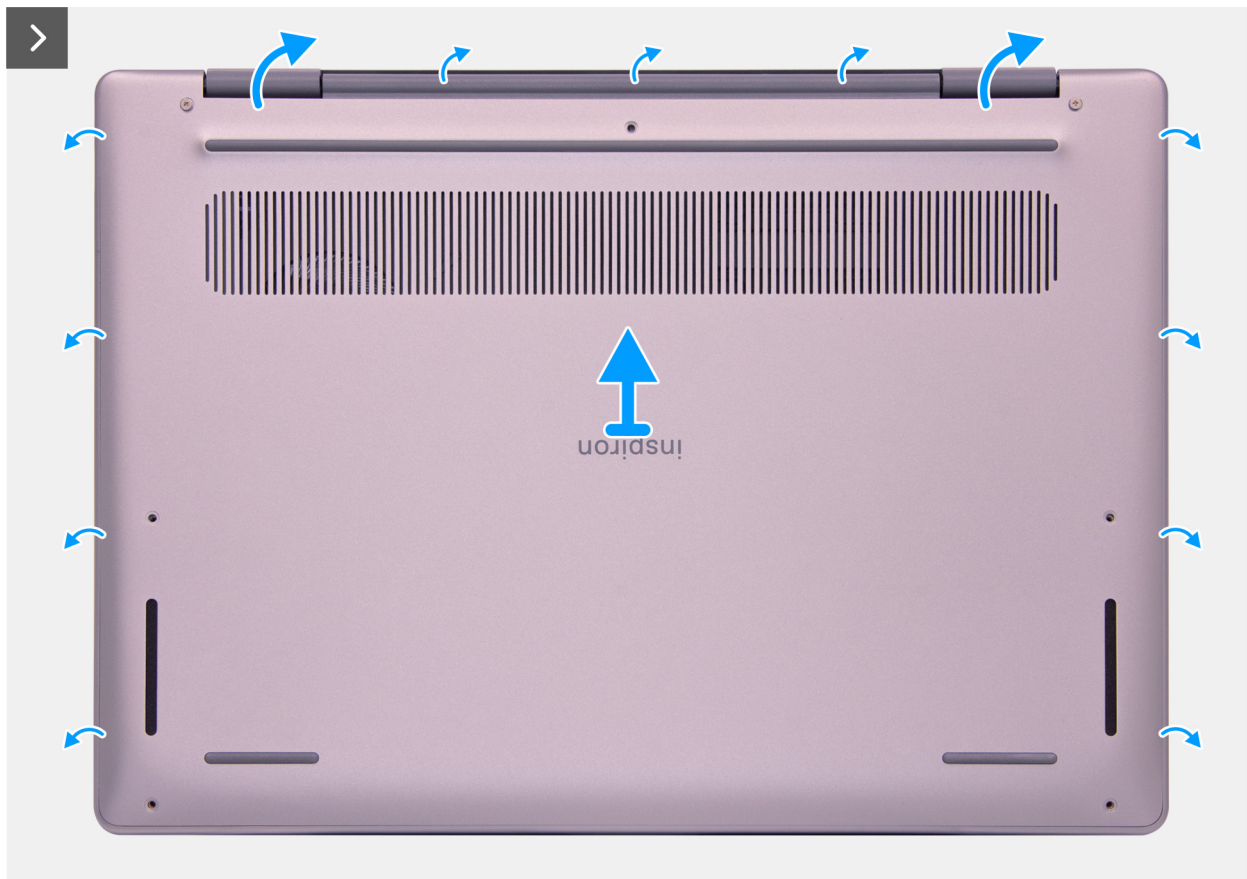

Figure 11. Removing the base cover

Steps

1. Remove the five screws (M2x5.5) and loosen the two captive screws (M2x7.9) that secure the base cover to the palm-rest and keyboard assembly.

i **NOTE:** Ensure to remove the five screws (M2x5.5) first to create the gap for prying the base cover off the palm-rest and keyboard assembly.

2. Using your fingers, pry open the base cover along the gap formed near the display hinges.
3. Lift the base cover off the palm-rest and keyboard assembly.

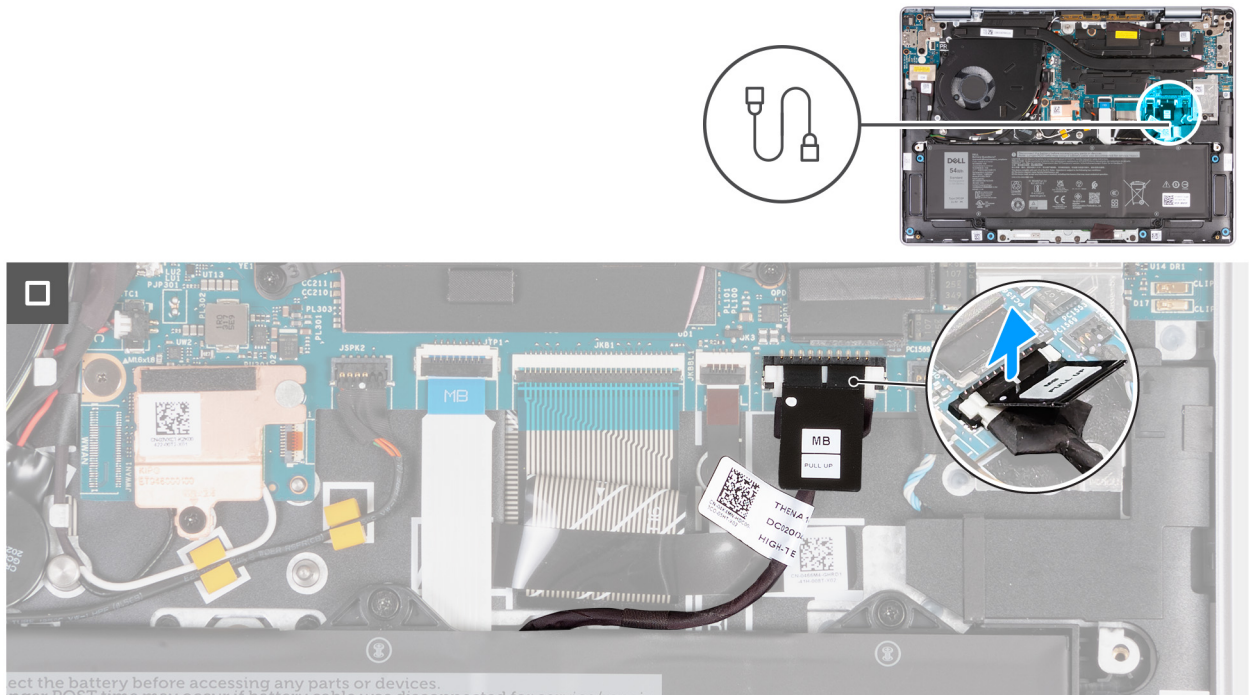

Figure 12. Disconnecting the battery cable

4. Disconnect the battery cable from the connector (BATTERY) on the system board.

Installing the base cover

Prerequisites

If you are replacing a component, remove the existing component before performing the installation procedure.

About this task

The following images indicate the location of the base cover and provide a visual representation of the installation procedure.

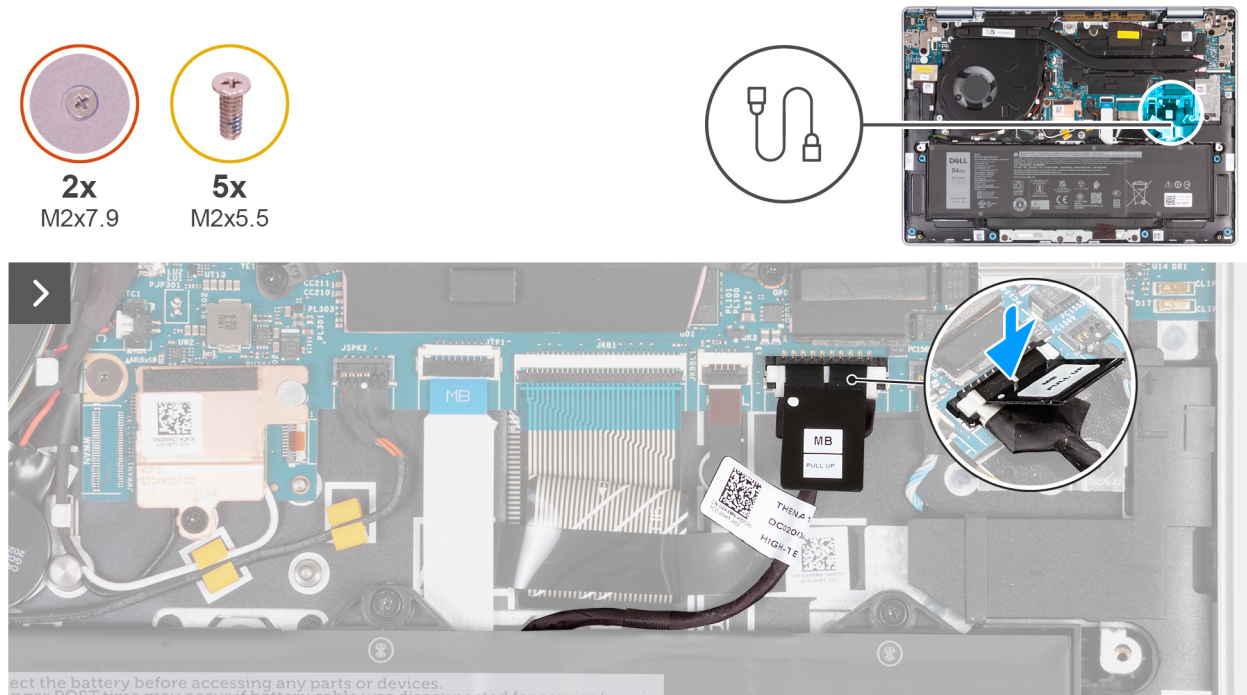

Figure 13. Connecting the battery cable

Steps

1. Connect the battery cable to the connector (BATTERY) on the system board.

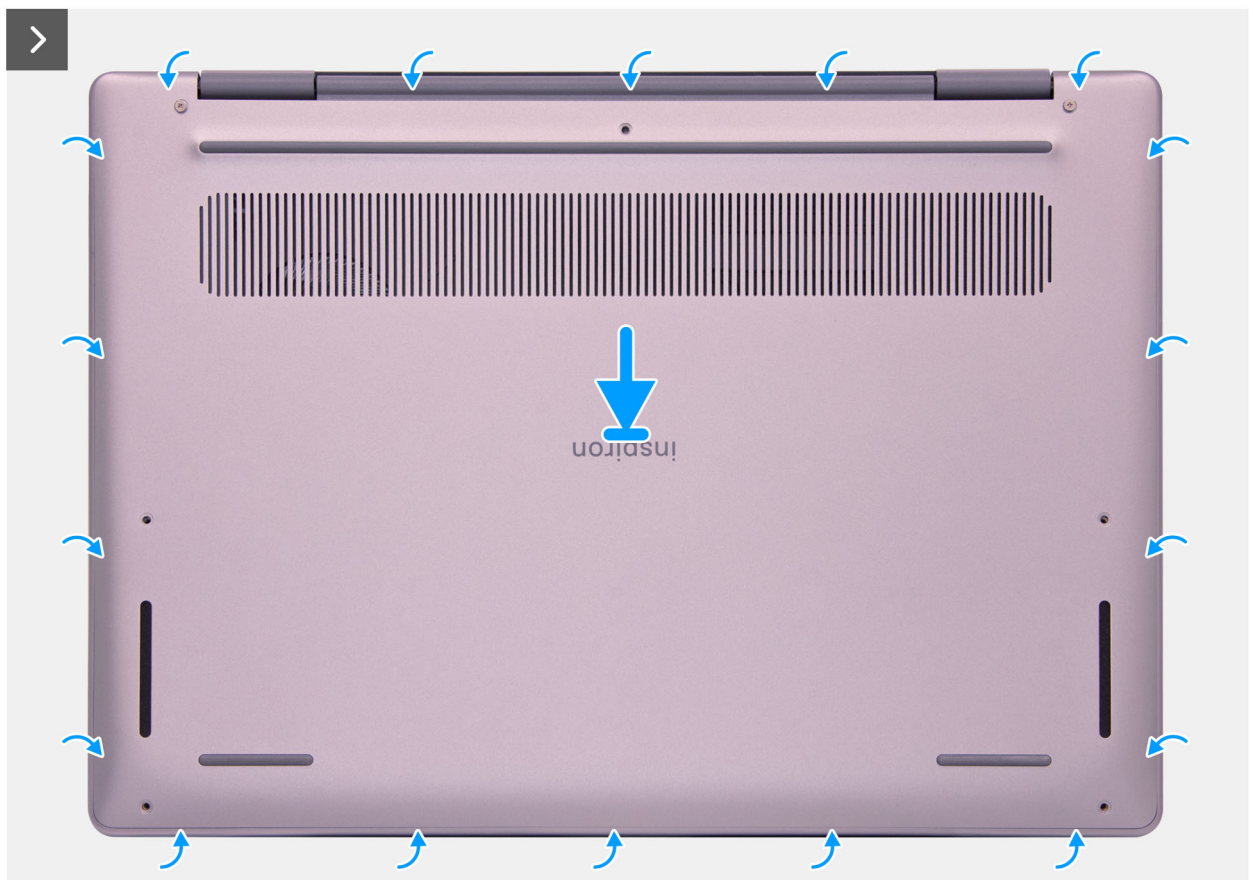

Figure 14. Installing the base cover



Figure 15. Installing the screws

2. Place the base cover on top of the palm-rest and keyboard assembly.
3. Align the screw holes on the base cover with the screw holes on the palm-rest and keyboard assembly, and snap the base cover into place.
4. Tighten the two captive screws (M2x7.9) and replace the five screws (M2x5.5) to secure the base cover to the palm-rest and keyboard assembly.

Next steps

1. Follow the procedure in [After working inside your computer](#).

Fan

Removing the fan



Click here to watch a video that demonstrates how to install the fan.

[Fan installation](#)

Prerequisites

1. Follow the procedure in [Before working inside your computer](#).
2. Remove the [base cover](#).

About this task

The following images indicate the location of the fan and provide a visual representation of the removal procedure.

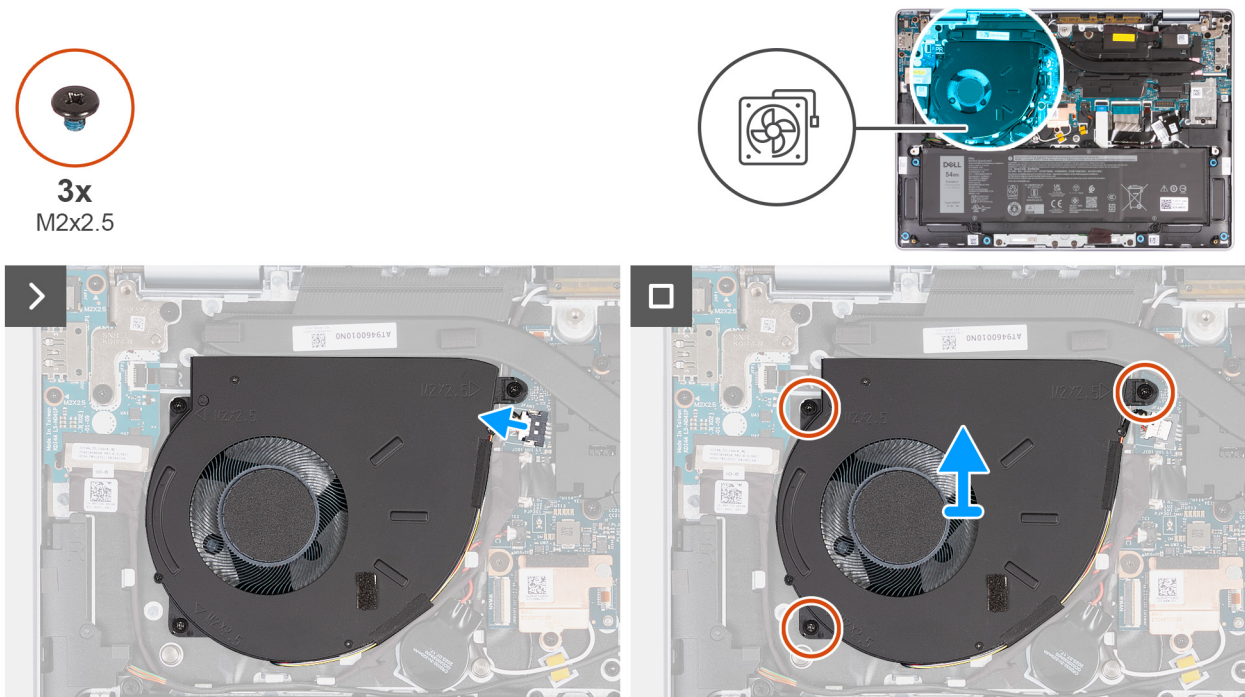

Figure 16. Removing the fan

Steps

1. Disconnect the fan cable from the connector (FAN) on the system board.
2. Remove the three screws (M2x2.5) that secure the fan to the palm-rest and keyboard assembly.
3. Lift the fan, along with the fan cable, off the palm-rest and keyboard assembly.

Installing the fan



Click here to watch a video that demonstrates how to install the fan.

[Fan installation](#)

Prerequisites

If you are replacing a component, remove the existing component before performing the installation procedure.

About this task

The following images indicate the location of the fan and provide a visual representation of the installation procedure.

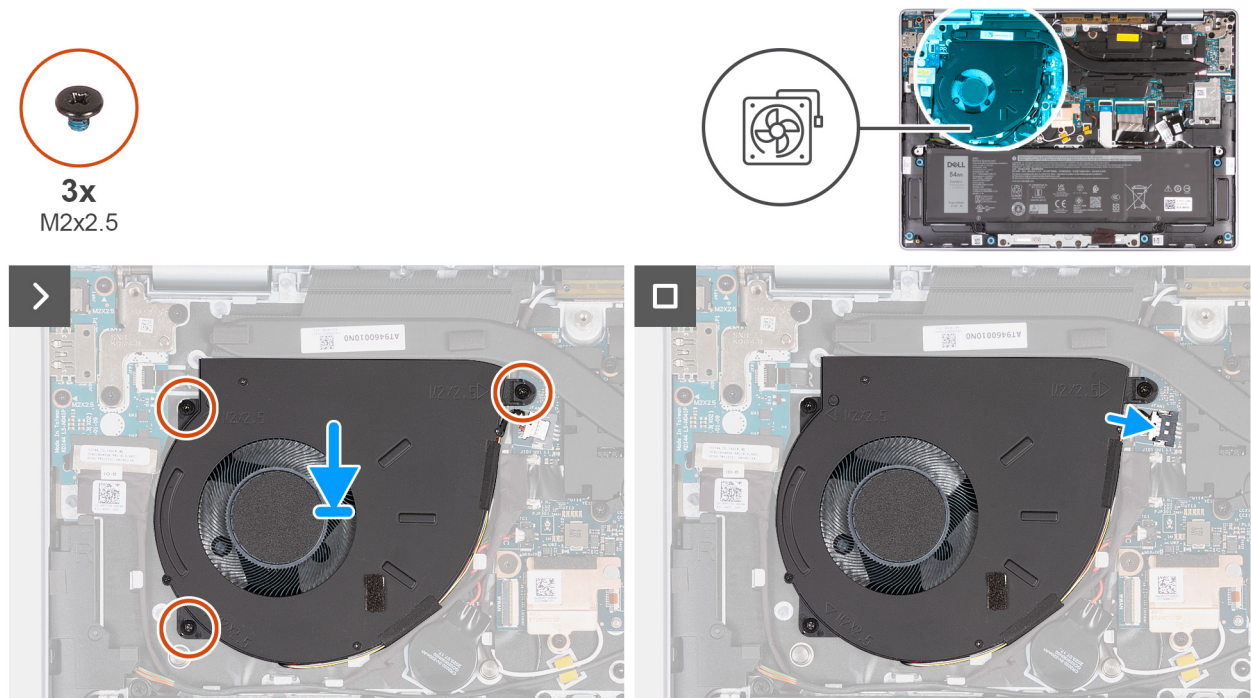

Figure 17. Installing the fan

Steps

1. Place and align the fan, along with the fan cable, in the slot on the palm-rest and keyboard assembly.

CAUTION: Avoid touching the fan blades to prevent damage.

2. Align the screw holes on the fan with the screw holes on the palm-rest and keyboard assembly.
3. Replace the three screws (M2x2.5) that secure the fan to the palm-rest and keyboard assembly.
4. Connect the fan cable to the connector (FAN) on the system board.

Next steps

1. Install the [base cover](#).
2. Follow the procedure in [After working inside your computer](#).

Solid state drive

Removing the solid state drive



Click here to watch a video that demonstrates how to install the solid state drive.

[Solid state drive installation](#)

Prerequisites

1. Follow the procedure in [Before working inside your computer](#).
2. Remove the [base cover](#).

About this task

The following images indicate the location of the solid state drive and provide a visual representation of the removal procedure.



1x
M2x2.5

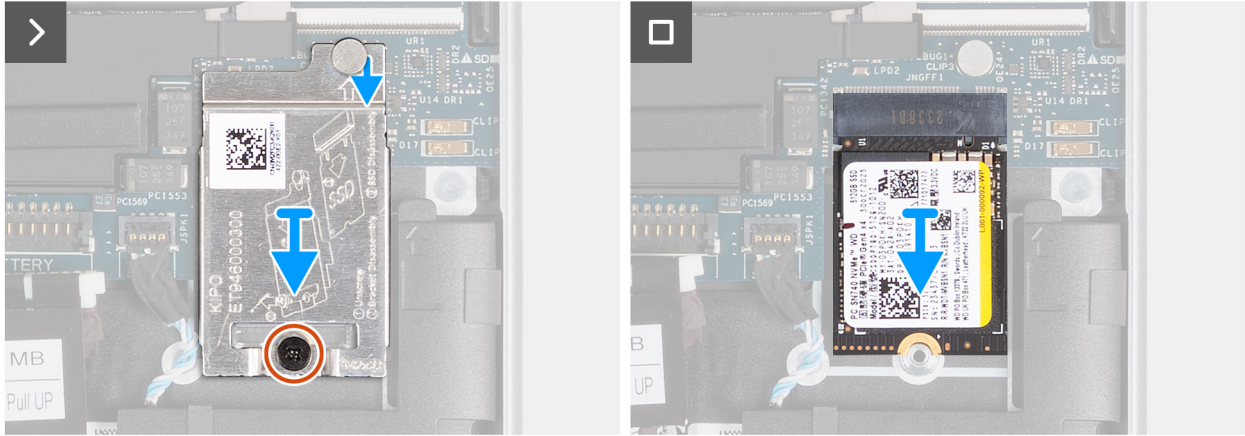
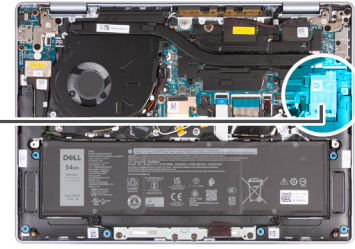

Figure 18. Removing the solid state drive

Steps

1. Remove the screw (M2x2.5) that secures the solid state drive thermal shield and the solid state drive to the palm-rest and keyboard assembly.
2. Slide and remove the solid state drive thermal shield from the slot on the system board.
3. Slide and remove the solid state drive from the M.2 solid state drive slot (SSD) on the system board.

Installing the solid state drive



[Click here to watch a video that demonstrates how to install the solid state drive.](#)

[Solid state drive installation](#)

Prerequisites

If you are replacing a component, remove the existing component before performing the installation procedure.

About this task

The following images indicate the location of the solid state drive and provide a visual representation of the installation procedure.

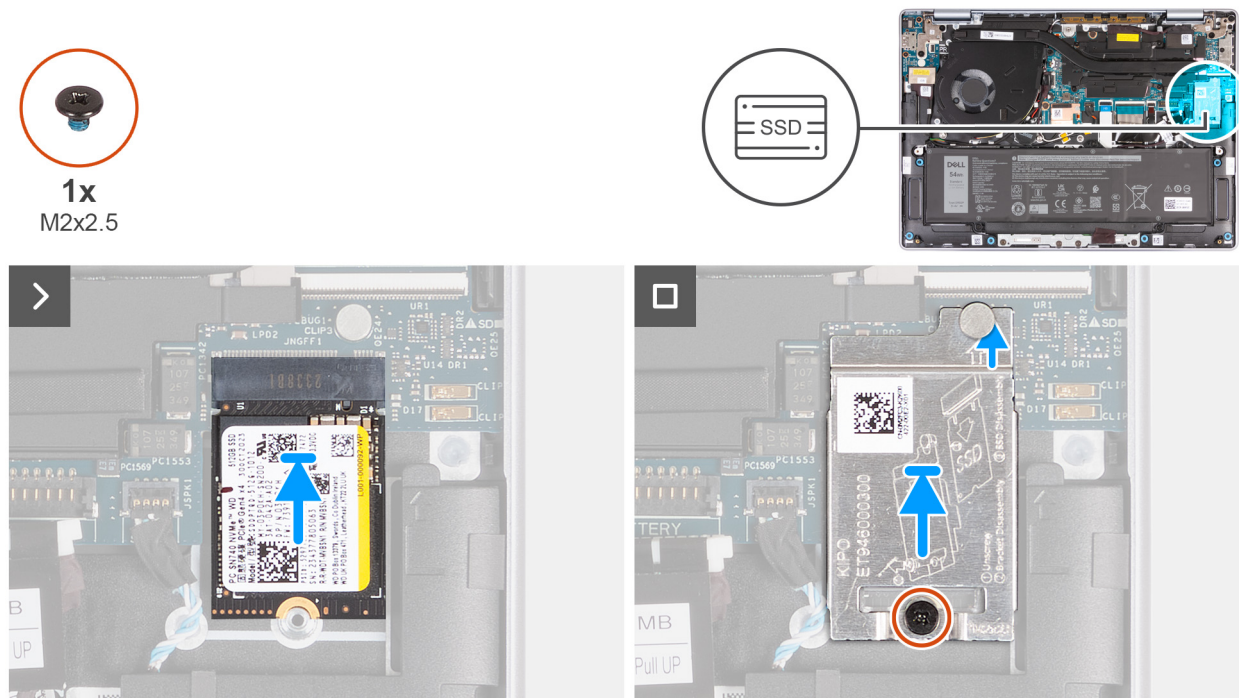

Figure 19. Installing the solid state drive

Steps

1. Align the notch on the M.2 2230 solid state drive with the tab on the M.2 solid state drive slot (SSD) on the system board.
2. Slide and place the M.2 2230 solid state drive in the M.2 solid state drive slot (SSD) on the system board.
3. Align the notch on the solid state drive thermal shield with the tab on the system board.

i NOTE: The solid state drive thermal shield includes a thermal pad attached below. Ensure to adhere the thermal pad back to its location if it is displaced during removal procedure.

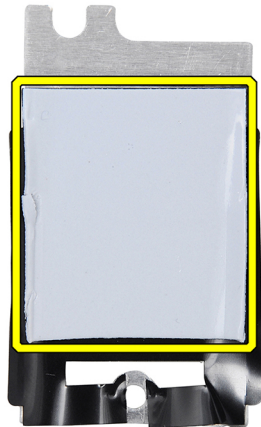

Figure 20. Thermal pad

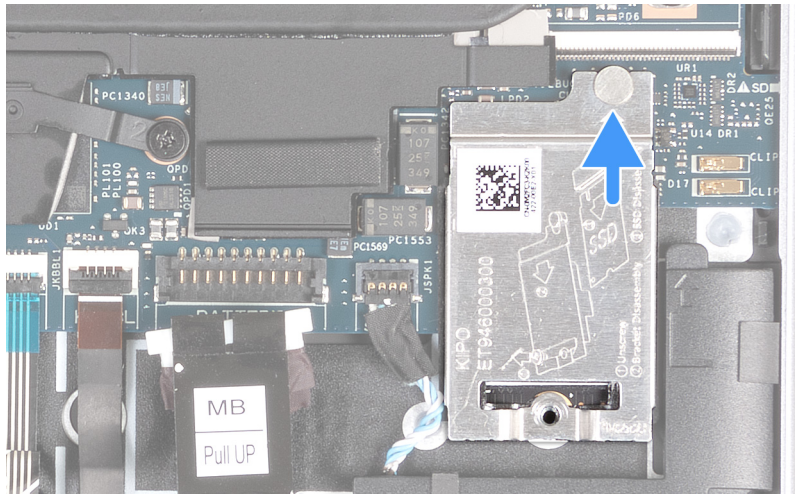

Figure 21. Installing solid state drive thermal shield

4. Align the screw hole on the solid state drive thermal shield with the screw hole on the palm-rest and keyboard assembly.
5. Replace the screw (M2x2.5) that secures the solid state drive thermal shield and the solid state drive to the palm-rest and keyboard assembly.

Next steps

1. Install the [base cover](#).
2. Follow the procedure in [After working inside your computer](#).

Speakers

Removing the speakers



Click here to watch a video that demonstrates how to install the speakers.

[Speaker installation](#)

Prerequisites

1. Follow the procedure in [Before working inside your computer](#).
2. Remove the [base cover](#).

About this task

The following images indicate the location of the speakers and provide a visual representation of the removal procedure.

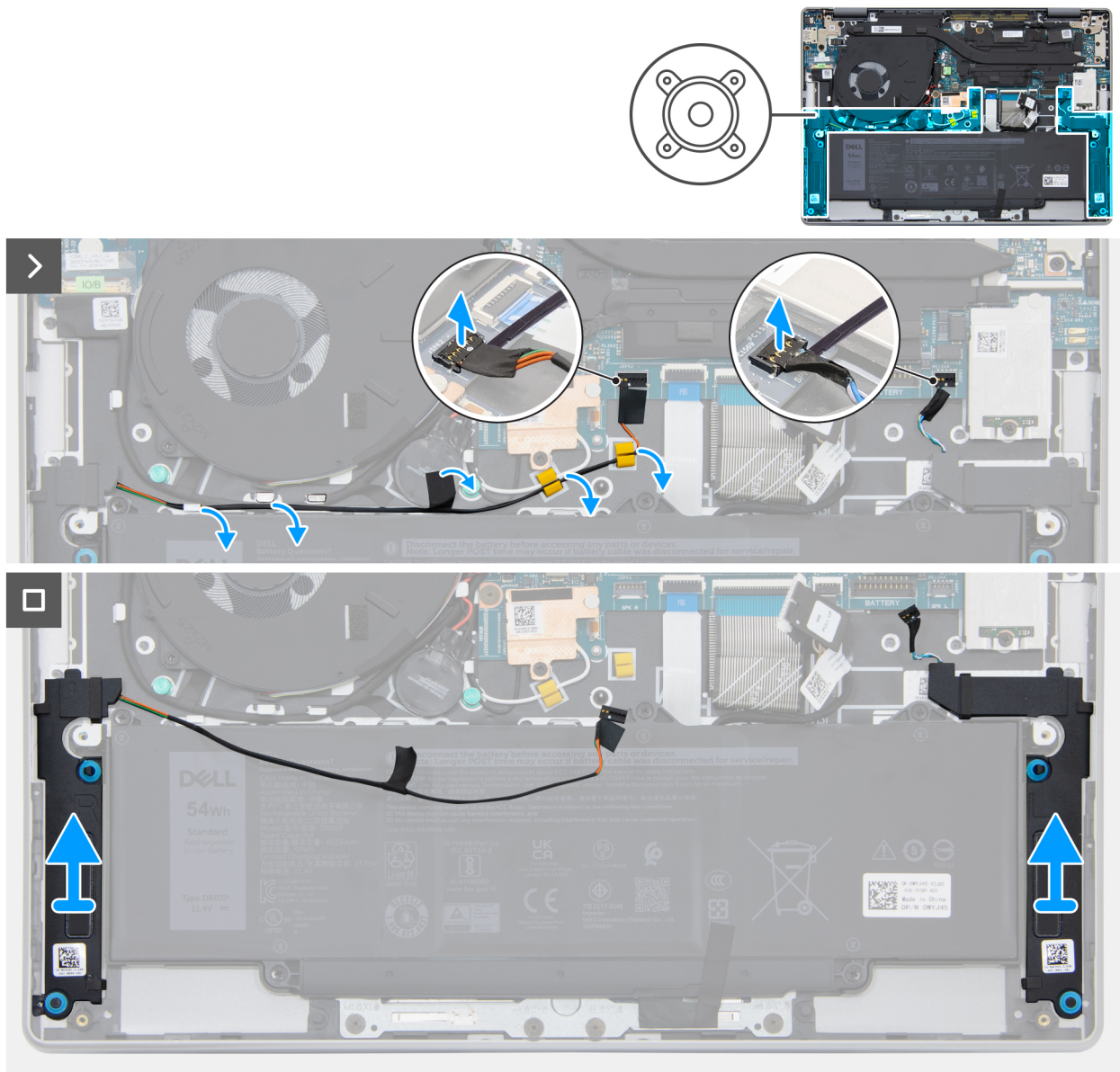

Figure 22. Removing the speakers

Steps

1. Disconnect the speaker cables from the respective connectors (SPK R and SPK L) on the system board.

CAUTION: To disconnect the speaker cables from the system board, pry the base of the cable connector's head first and then pull it away from the respective connectors (SPK R and SPK L) on the system board. Do not pull the cables downward to disconnect the speaker cables from the system board.

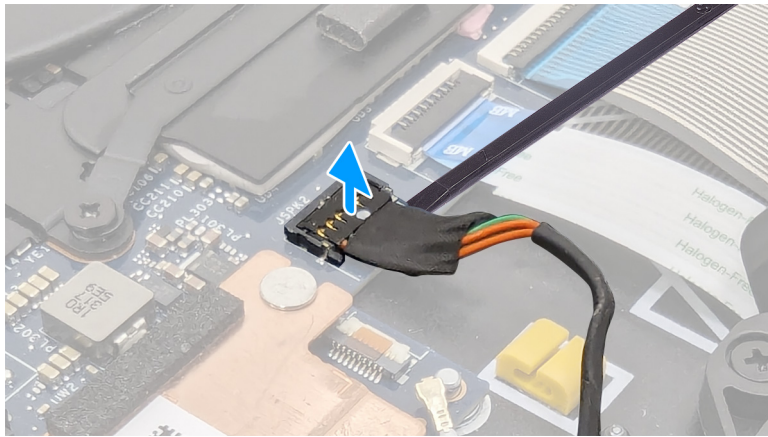

Figure 23. Disconnecting speaker cable

2. Remove the right speaker cable from the routing guides on the palm-rest and keyboard assembly.
3. Lift the speakers, along with the cables, off the palm-rest and keyboard assembly.

Installing the speakers



Click here to watch a video that demonstrates how to install the speakers.

[Speaker installation](#)

Prerequisites

If you are replacing a component, remove the existing component before performing the installation procedure.

About this task

The following images indicate the location of the speakers and provide a visual representation of the installation procedure.

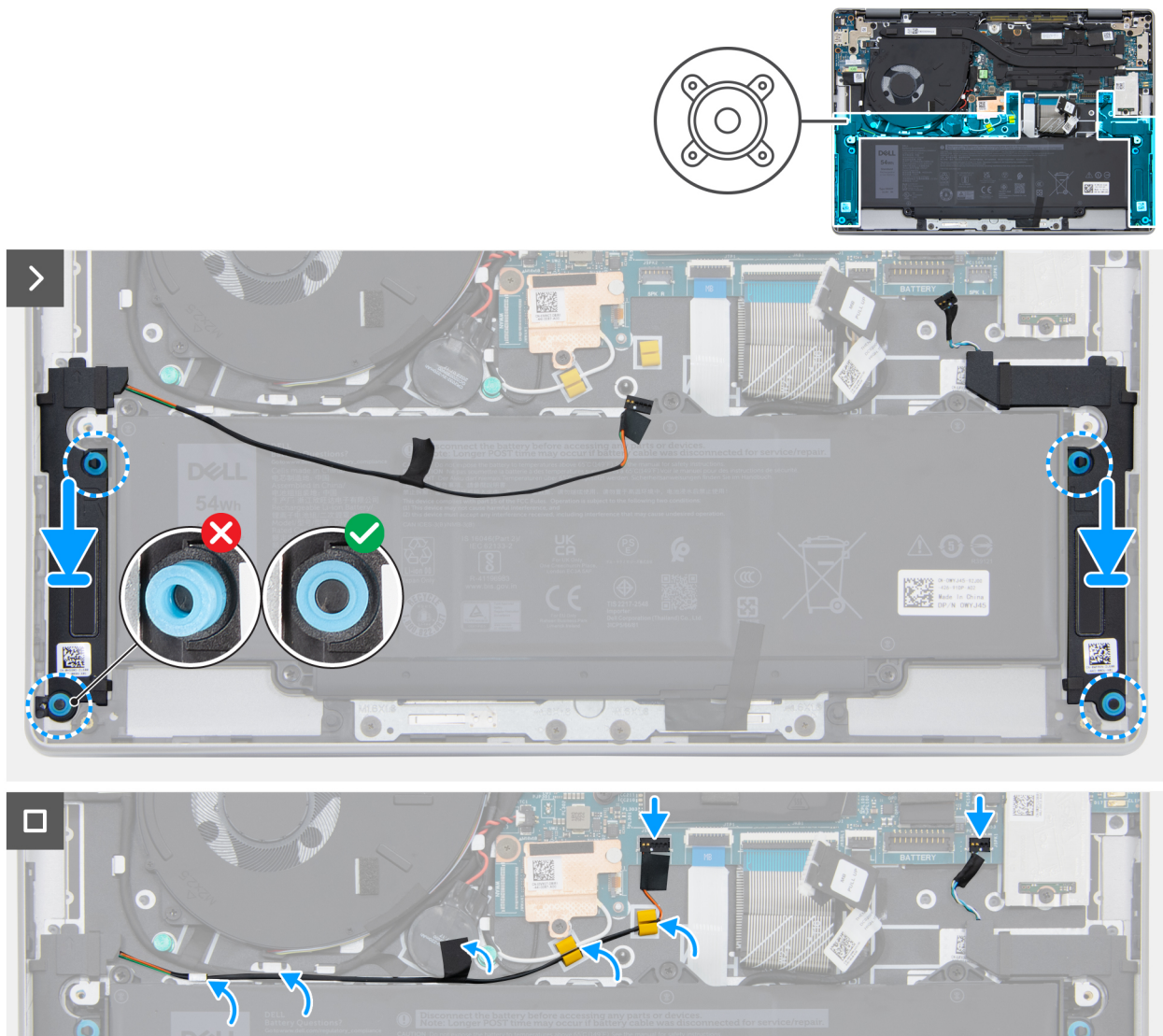

Figure 24. Installing the speakers

NOTE: If the rubber grommets are pushed out when removing the speakers, push them back in before replacing the speakers.

Steps

1. Using the alignment posts and the rubber grommets, place the respective speakers into the speaker slots on the palm-rest and keyboard assembly.

NOTE: Ensure that the rubber grommets are seated on the alignment posts.

2. Route the right speaker cable along the routing guides on the palm-rest and keyboard assembly.

NOTE: The speaker cable must be routed through the routing guides to avoid damaging the speaker cable when installing the base cover.

3. Connect the speaker cables to the respective connectors (SPK R and SPK L) on the system board.

Next steps

1. Install the [base cover](#).
2. Follow the procedure in [After working inside your computer](#).

Removing and installing Field Replaceable Units (FRUs)

The replaceable components in this chapter are Field Replaceable Units (FRUs).

CAUTION: The information in this section is intended for authorized service technicians only.

CAUTION: To avoid any potential damage to the component or loss of data, ensure that an authorized service technician replaces the Field Replaceable Units (FRUs).

CAUTION: Dell Technologies recommends that this set of repairs, if needed, to be conducted by trained technical repair specialists.

CAUTION: As a reminder, your warranty does not cover damages that may occur during FRU repairs that are not authorized by Dell Technologies.

NOTE: The images in this document may differ from your computer depending on the configuration you ordered.

Battery

Rechargeable Li-ion battery precautions

CAUTION:

- Exercise caution when handling rechargeable Li-ion batteries.
- Discharge the battery completely before removing it. Disconnect the AC power adapter from the computer and operate the computer solely on battery power—the battery is fully discharged when the computer no longer turns on when the power button is pressed.
- Do not crush, drop, mutilate, or penetrate the battery with foreign objects.
- Do not expose the battery to high temperatures, or disassemble battery packs and cells.
- Do not apply pressure to the surface of the battery.
- Do not bend the battery.
- Do not use tools of any kind to pry on or against the battery.
- To prevent accidental puncture or damage to the battery and other components, ensure that no screws are lost or misplaced during the servicing of this product.
- If the battery gets stuck inside your computer as a result of swelling, do not try to release it as puncturing, bending, or crushing a rechargeable Li-ion battery can be dangerous. In such an instance, contact Dell technical support for assistance. See [Contact Support at Dell Support Site](#).
- Always purchase genuine batteries from [Dell Site](#) or authorized Dell partners and resellers.
- Swollen batteries should not be used and should be replaced and disposed properly. For guidelines on how to handle and replace swollen rechargeable Li-ion batteries, see [Handling swollen rechargeable Li-ion batteries](#).

Removing the battery

CAUTION: The information in this section is intended for authorized service technicians only.

Prerequisites

1. Follow the procedure in [Before working inside your computer](#).
2. Remove the [base cover](#).

About this task

The following images indicate the location of the battery and provide a visual representation of the removal procedure.

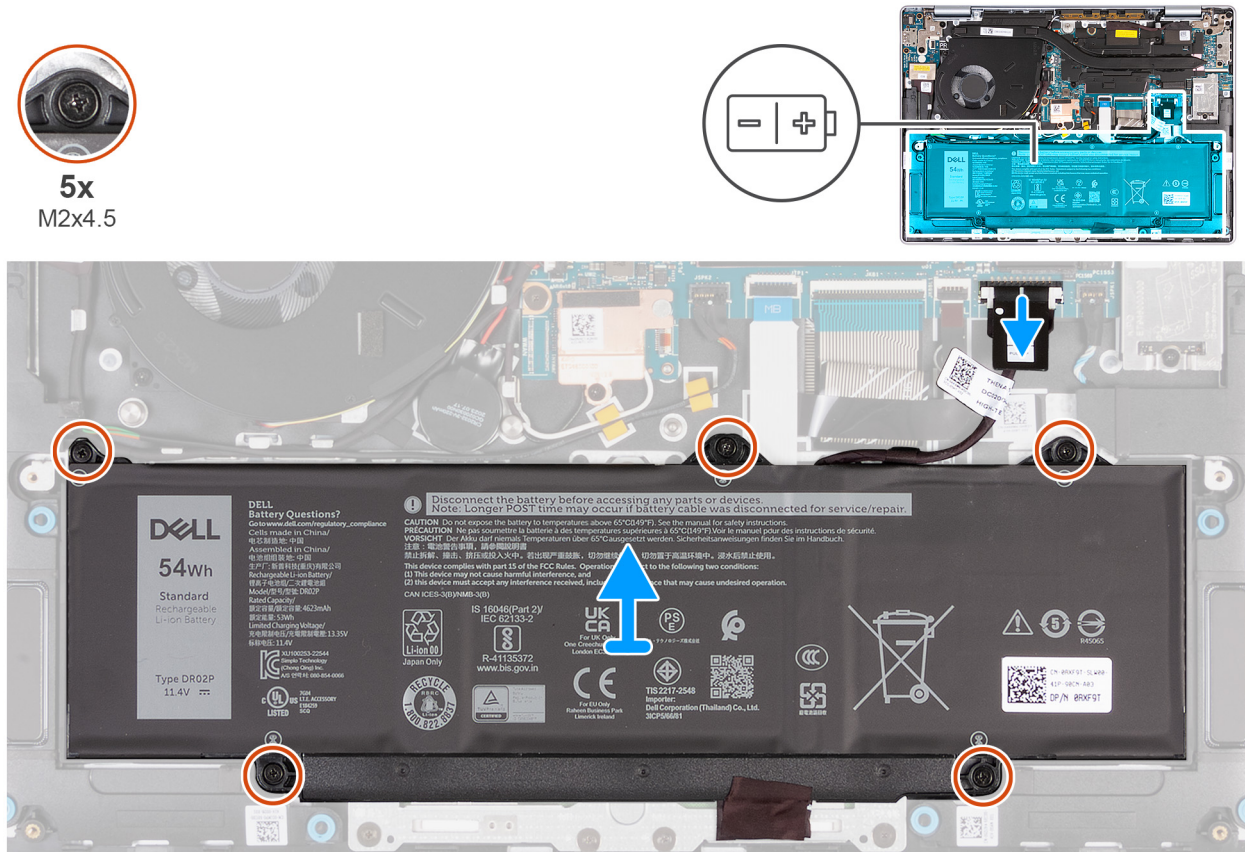

Figure 25. Removing the battery

Steps

1. Disconnect the battery cable from the connector (BATTERY) on the system board.
2. Loosen the five captive screws (M2x4.5) that secure the battery to the palm-rest and keyboard assembly.
3. Lift the battery, along with the battery cable, off the palm-rest and keyboard assembly.

NOTE: The battery and the battery cable are separate serviceable parts. If battery replacement is required, reuse the existing battery cable. To disconnect the battery cable, see [Disconnecting the battery cable](#).

Installing the battery

CAUTION: The information in this section is intended for authorized service technicians only.

Prerequisites

If you are replacing a component, remove the existing component before performing the installation procedure.

About this task

The following images indicate the location of the battery and provide a visual representation of the installation procedure.



5x
M2x4.5

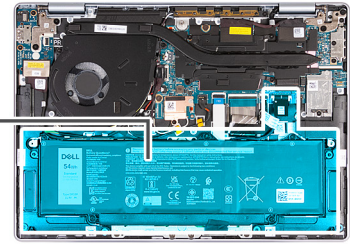
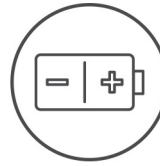

Figure 26. Installing the battery

NOTE: The battery and the battery cable are separate serviceable parts. If battery replacement is required, reuse the existing battery cable. To connect the battery cable, see [Connecting the battery cable](#).

Steps

1. Place the battery, with the battery cable connected to it, in the slot on the palm-rest and keyboard assembly.
2. Align the screw holes on the battery with the screw holes on the palm-rest and keyboard assembly.
3. Tighten the five captive screws (M2x4.5) that secure the battery to the palm-rest and keyboard assembly.
4. Connect the battery cable to the connector (BATTERY) on the system board.

Next steps

1. Install the [base cover](#).
2. Follow the procedure in [After working inside your computer](#).

Battery cable

Disconnecting the battery cable

CAUTION: The information in this section is intended for authorized service technicians only.

Prerequisites

1. Follow the procedure in [Before working inside your computer](#).
2. Remove the [base cover](#).
3. Remove the [battery](#).

About this task

The following images indicate the location of the battery cable and provide a visual representation of the removal procedure.

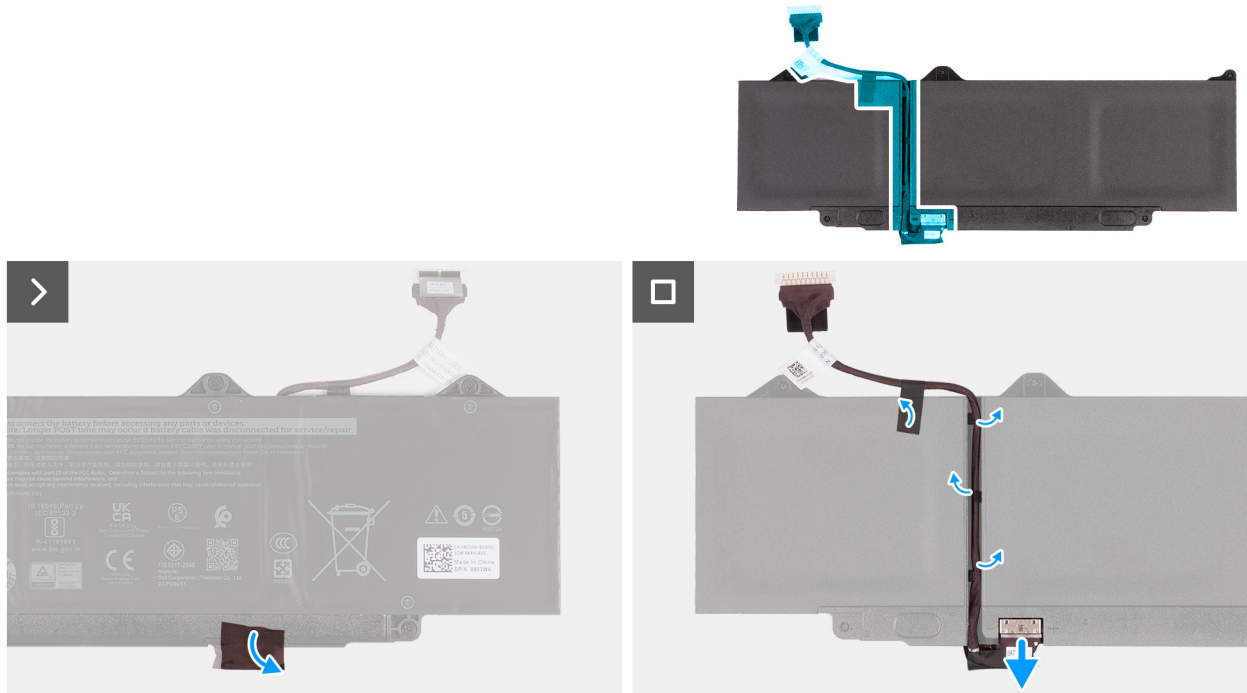

Figure 27. Disconnecting the battery cable

Steps

1. Remove the Mylar that adheres the connector to the battery.
2. Turn the battery over.
3. Pull the battery cable downward and disconnect it from its connector on the battery.
4. Remove the battery cable from the routing guides on the battery.

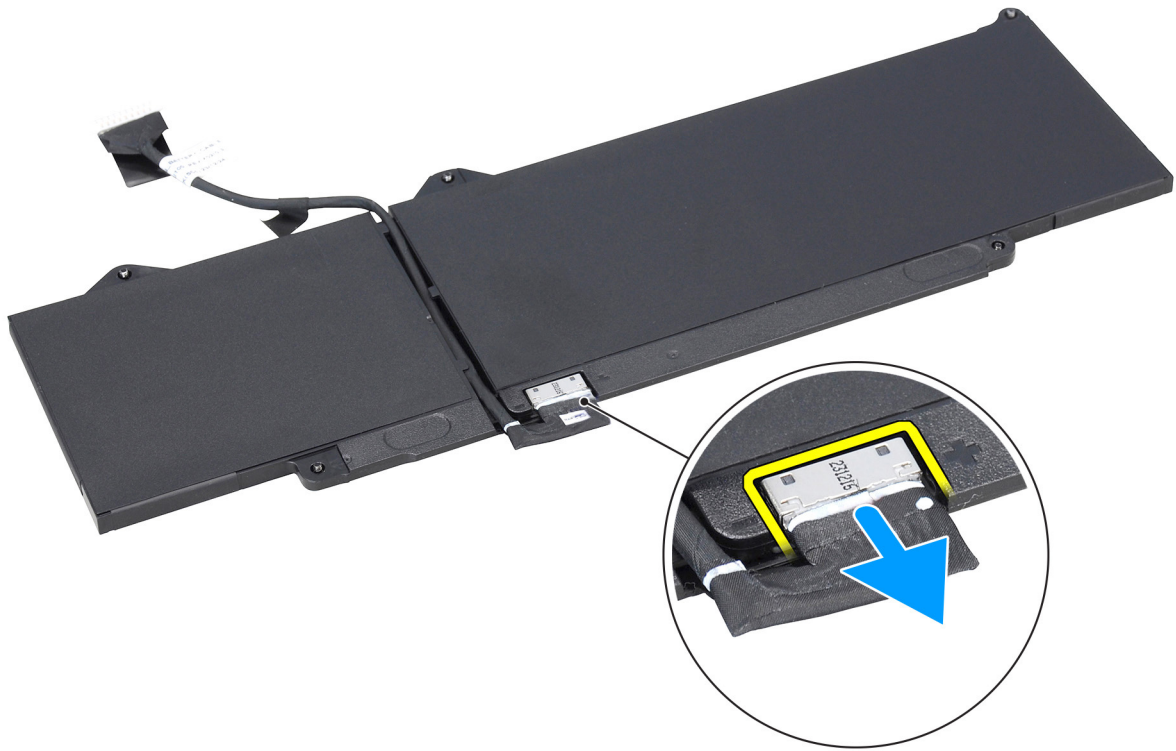

Figure 28. Disconnecting the battery cable

CAUTION: Do not pull the battery cable upward to disconnect it from the battery. This action may damage the battery or the battery cable.

Connecting the battery cable

CAUTION: The information in this section is intended for authorized service technicians only.

Prerequisites

If you are replacing a component, remove the existing component before performing the installation procedure.

About this task

The following images indicate the location of the battery cable and provide a visual representation of the installation procedure.

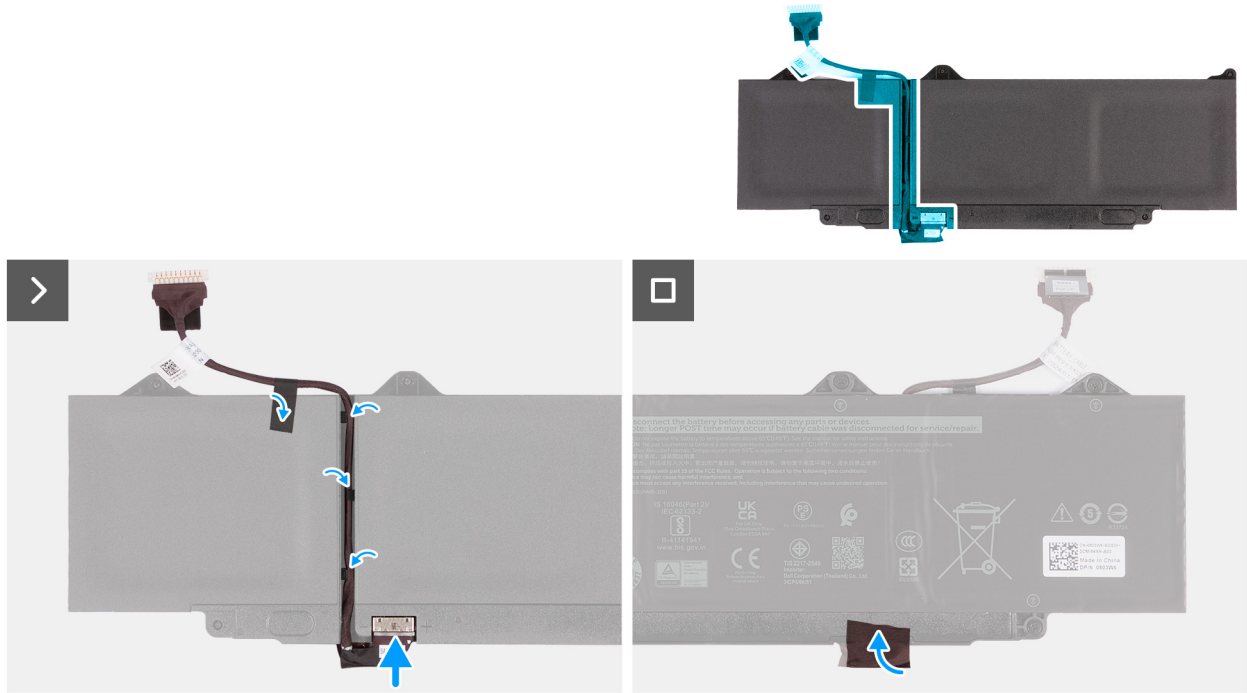

Figure 29. Connecting the battery cable

Steps

1. Route the battery cable through the routing guides on the battery.
2. Connect the battery cable to the connector on the battery.
3. Turn the battery over and adhere the Mylar to secure the connector to the battery.

Next steps

1. Install the [battery](#).
2. Install the [base cover](#).
3. Follow the procedure in [After working inside your computer](#).

Coin-cell battery

Removing the coin-cell battery

Prerequisites

1. Follow the procedure in [Before working inside your computer](#).
2. Remove the [base cover](#).

About this task

⚠ WARNING: This computer contains a coin-cell battery and requires trained technicians for handling guidance.

ℹ NOTE: Removing the coin-cell battery clears the CMOS settings.

The following images indicate the location of the coin-cell battery and provide a visual representation of the removal procedure.

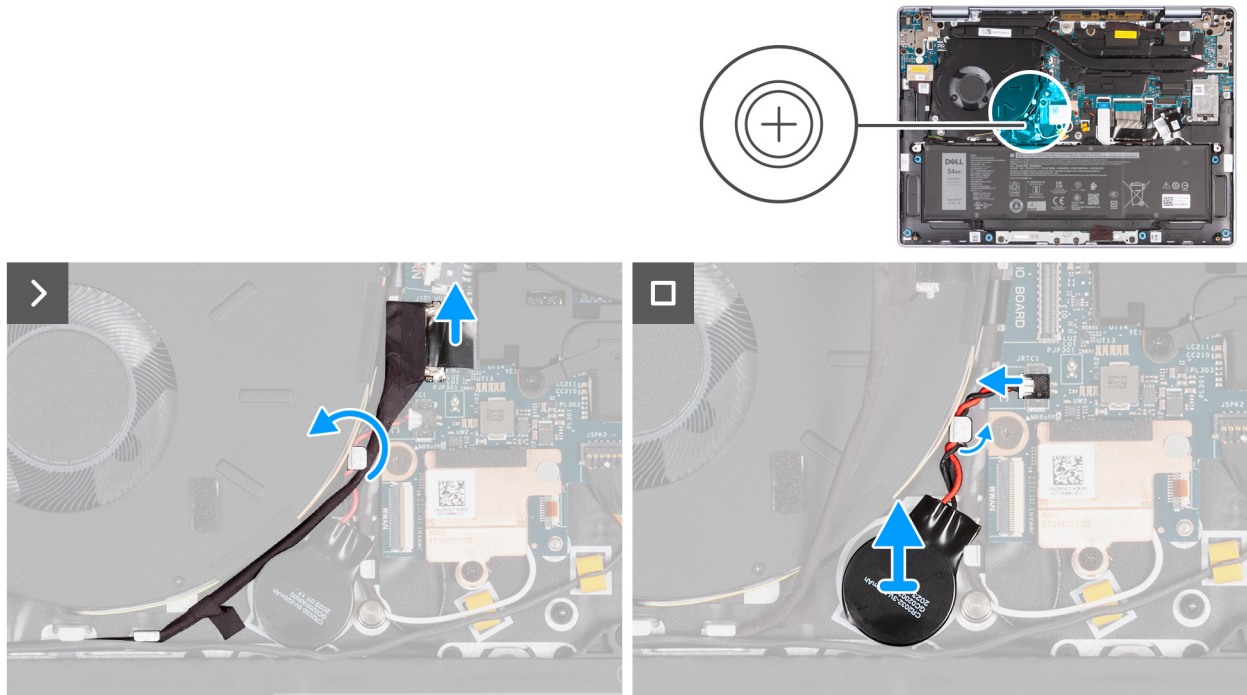

Figure 30. Removing the coin-cell battery

Steps

1. Disconnect the I/O-board cable from the connector (IO BOARD) on the system board.
2. Remove the I/O-board cable from the routing guide on the palm-rest and keyboard assembly.
3. Disconnect the coin-cell battery cable from the connector (RTC) on the system board.
4. Remove the coin-cell battery cable from the routing guide on the palm-rest and keyboard assembly.
5. Pry the coin-cell battery off the palm-rest and keyboard assembly.

Installing the coin-cell battery

Prerequisites

If you are replacing a component, remove the existing component before performing the installation procedure.

About this task

⚠️ WARNING: This computer contains a coin-cell battery and requires trained technicians for handling guidance.

The following images indicate the location of the coin-cell battery and provide a visual representation of the installation procedure.

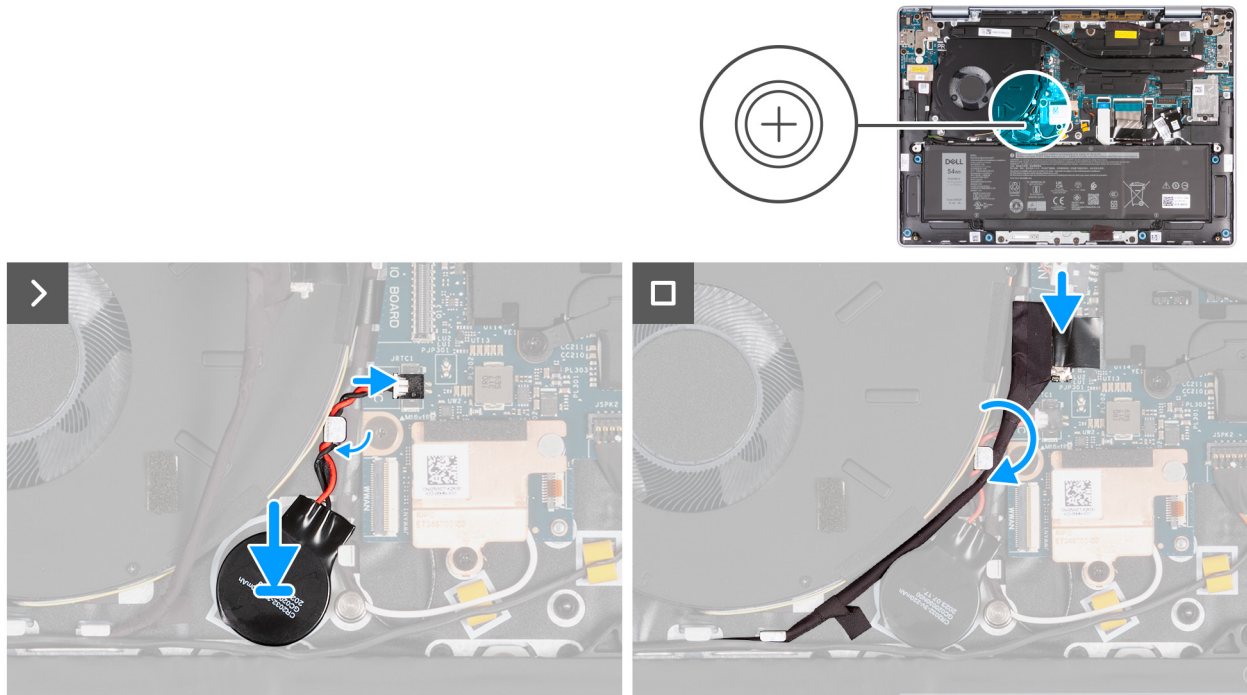

Figure 31. Installing the coin-cell battery

Steps

1. Align and adhere the coin-cell battery on the palm-rest and keyboard assembly.
2. Route the coin-cell battery cable through the routing guide on the palm-rest and keyboard assembly.
3. Connect the coin-cell battery cable to the connector (RTC) on the system board.
4. Route the I/O-board cable through the routing guide on the palm-rest and keyboard assembly.
5. Connect the I/O-board cable to the connector (IO BOARD) on the system board.

Next steps

1. Install the [base cover](#).
2. Follow the procedure in [After working inside your computer](#).

Display assembly

Removing the display assembly

⚠ CAUTION: The information in this section is intended for authorized service technicians only.

⚠ CAUTION: The maximum operating angle for the display-panel hinge is 135 degrees.

Prerequisites

1. Follow the procedure in [Before working inside your computer](#).
2. Remove the [base cover](#).

About this task

The following images indicate the location of the display assembly and provide a visual representation of the removal procedure.



4x
M2.5x4.5

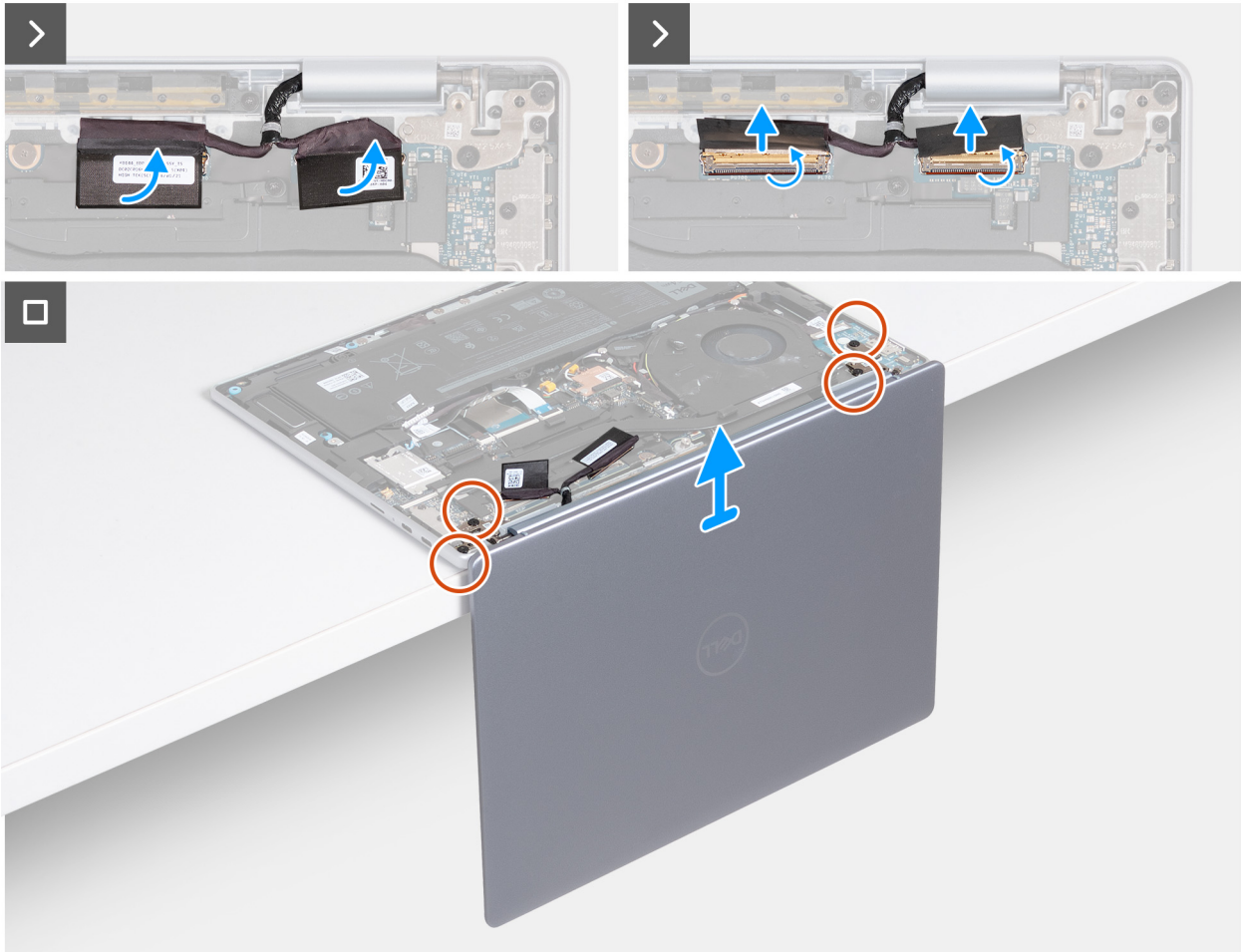
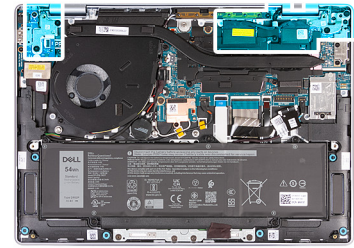

Figure 32. Removing the display assembly

Steps

1. Peel the Mylar and open the latch on the camera connector (MIPI) on the system board.
2. Disconnect the camera cable on the camera connector (MIPI) on the system board.
3. Peel the Mylar and open the latch from the display connector (EDP) on the system board.
4. Disconnect the display cable from the display connector (EDP) on the system board.
5. Open the display to a 90-degree angle and place the computer at the edge of a flat table.
6. Remove the four screws (M2.5x4.5) that secure the left and the right display hinges to the palm-rest and keyboard assembly.
7. Lift the display assembly off the palm-rest and keyboard assembly.
8. After performing all the above steps, you are left with the display assembly.

i NOTE: The display assembly is a Hinge-Up Design (HUD) assembly which cannot be further disassembled. If any components in the display assembly malfunction and require replacement, the entire display assembly has to be replaced.



Figure 33. Display assembly

Installing the display assembly

CAUTION: The information in this section is intended for authorized service technicians only.

CAUTION: The maximum operating angle for the display-panel hinge is 135 degrees.

Prerequisites

If you are replacing a component, remove the existing component before performing the installation procedure.

About this task

The following images indicate the location of the display assembly and provide a visual representation of the installation procedure.



4x
M2.5x4.5

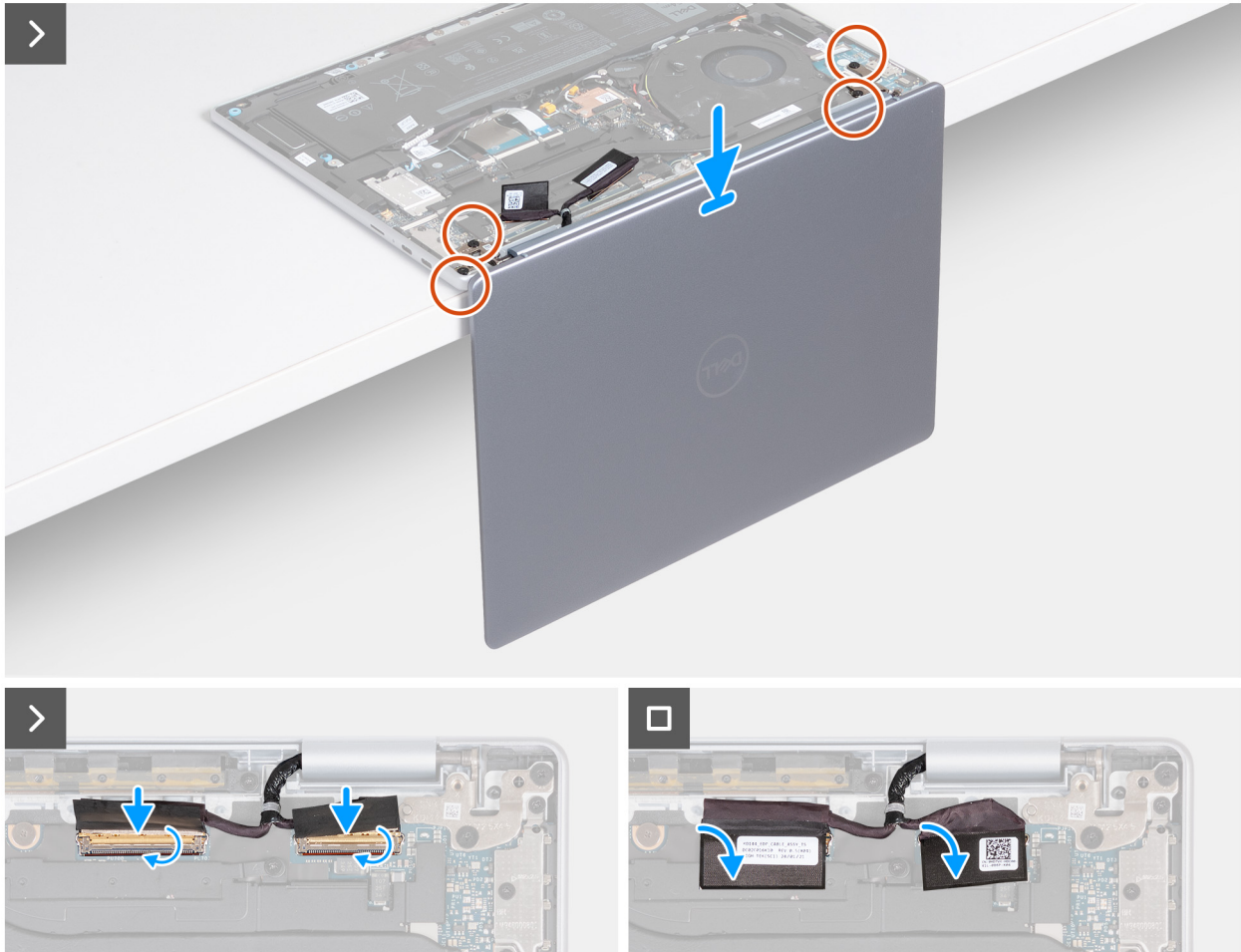
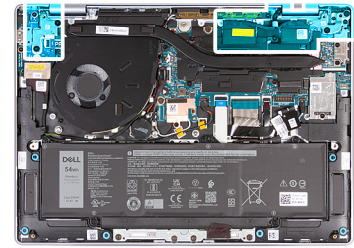

Figure 34. Installing the display assembly

Steps

1. Place the palm-rest and keyboard assembly at the edge of a flat table.
2. Open the hinges of the display assembly to a 90-degree angle.
3. Align the screw holes on the display hinges with the screw holes on the palm-rest and keyboard assembly.
4. Replace the four screws (M2.5x4.5) that secure the left and the right display hinges to the palm-rest and keyboard assembly.
5. Connect the display cable to the display connector (EDP) on the system board.
6. Close the latch and adhere the Mylar to the display connector (EDP) on the system board.
7. Connect the camera cable to the camera connector (MIPI) on the system board.
8. Close the latch and adhere the Mylar to the camera connector (MIPI) on the system board.

Next steps

1. Install the [base cover](#).
2. Follow the procedure in [After working inside your computer](#).

Heat sink

Removing the heat sink

CAUTION: The information in this section is intended for authorized service technicians only.

Prerequisites

1. Follow the procedure in [Before working inside your computer.](#)
2. Remove the [base cover.](#)

About this task

- NOTE:** The heat sink may become hot during normal operation. Allow sufficient time for the heat sink to cool before you touch it.
- NOTE:** For maximum heat dissipation, do not touch the heat transfer areas on the heat sink. The oils in your skin can reduce the heat transfer capability of the thermal grease.

The following images indicate the location of the battery and provide a visual representation of the removal procedure.

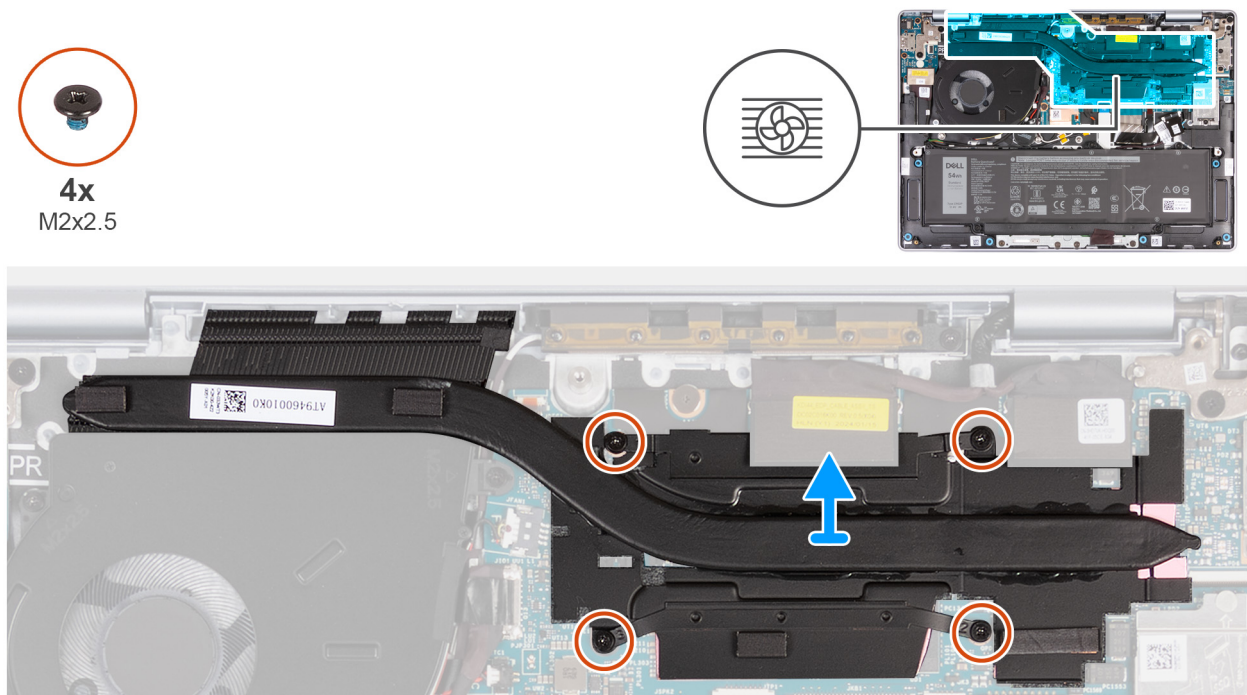

Figure 35. Removing the heat sink

Steps

1. In reverse sequential order (4->3->2->1), remove the four screws (M2x2.5) that secure the heat sink to the system board.
2. Lift the heat sink off the system board.

Installing the heat sink

CAUTION: The information in this section is intended for authorized service technicians only.

Prerequisites

If you are replacing a component, remove the existing component before performing the installation process.

About this task

The following images indicate the location of the heat sink and provide a visual representation of the installation procedure.

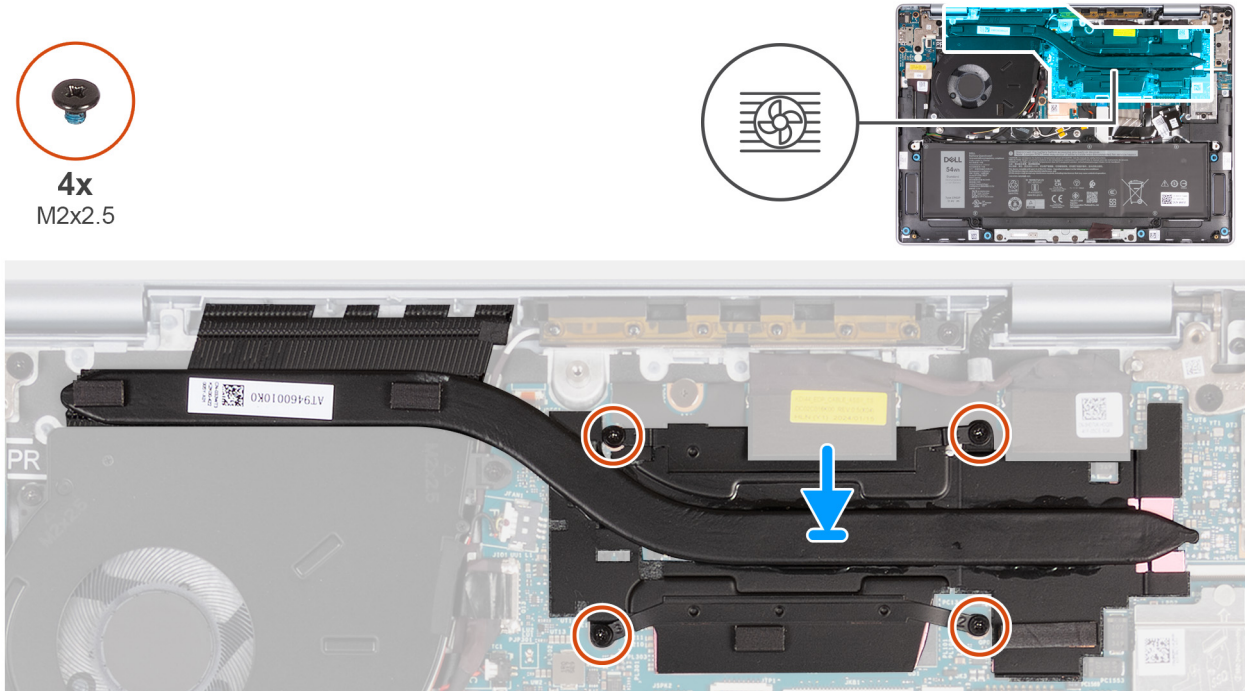

Figure 36. Installing the heat sink

Steps

1. Place the heat sink on the system board.
2. Align the screw holes on the heat sink with the screw holes on the system board.
3. In sequential order (1->2->3->4), replace the four screws (M2x2.5) that secure the heat sink to the system board.

Next steps

1. Install the [base cover](#).
2. Follow the procedure in [After working inside your computer](#).

Touchpad

Removing the touchpad

CAUTION: The information in this section is intended for authorized service technicians only.

Prerequisites

1. Follow the procedure in [Before working inside your computer](#).
2. Remove the [base cover](#).
3. Remove the [battery](#).

About this task

The following images indicate the location of the touchpad and provide a visual representation of the removal procedure.



9x
M1.6x1.8

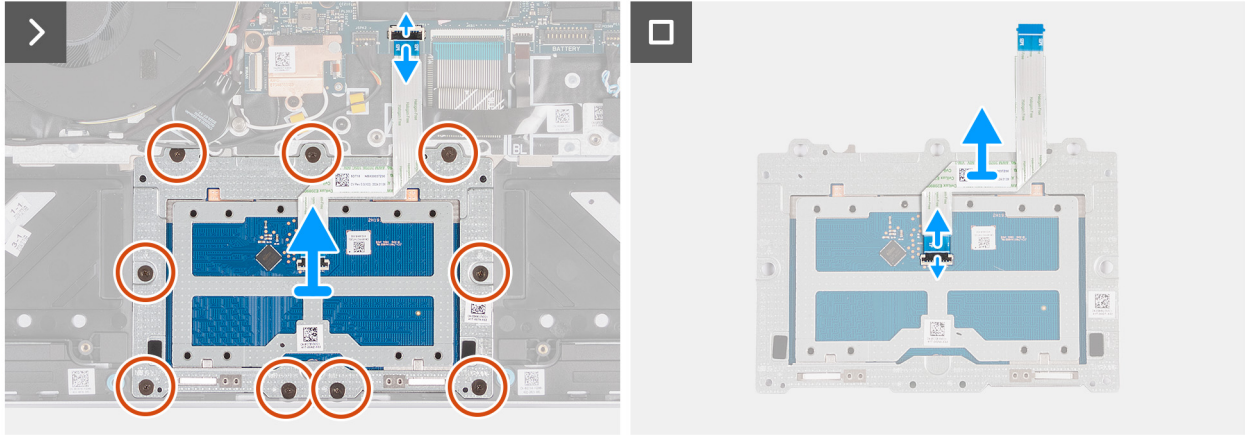
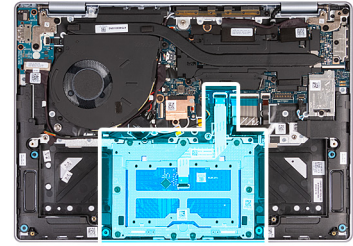

Figure 37. Removing the touchpad

Steps

1. Open the latch and disconnect the touchpad cable from the connector (TP) on the system board.
2. Remove the nine screws (M1.6x1.8) that secure the touchpad bracket to the palm-rest and keyboard assembly.
3. Lift the touchpad bracket off the palm-rest and keyboard assembly.
4. Open the latch and disconnect the touchpad cable from the connector on the touchpad.

Installing the touchpad

CAUTION: The information in this section is intended for authorized service technicians only.

Prerequisites

If you are replacing a component, remove the existing component before performing the installation procedure.

About this task

The following images indicate the location of the touchpad and provide a visual representation of the installation procedure.



9x
M1.6x1.8

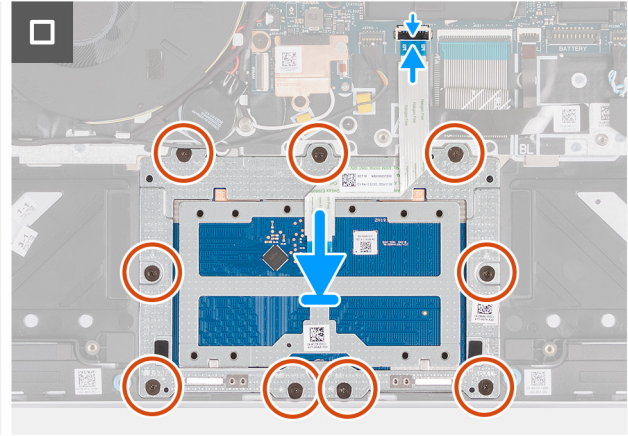
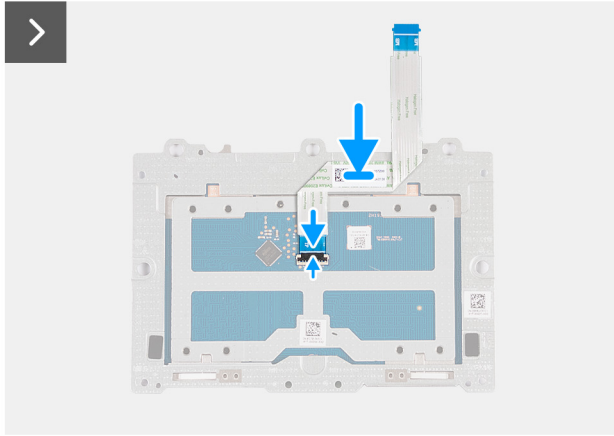
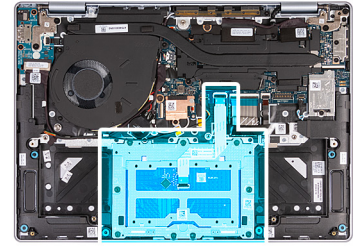

Figure 38. Installing the touchpad

NOTE: Ensure that the touchpad is aligned with the guides on the palm-rest and keyboard assembly, and the gap on either side of the touchpad is equal.

Steps

1. Connect the touchpad cable and close the latch of the connector on the touchpad.
2. Align and place the touchpad bracket in the slot on the palm-rest and keyboard assembly.
3. Align the screw holes on the touchpad bracket with the screw holes on the palm-rest and keyboard assembly.
4. Replace the nine screws (M1.6x1.8) that secure the touchpad to the palm-rest and keyboard assembly.
5. Connect the touchpad cable and close the latch of the connector (TP) on the system board.

Next steps

1. Install the [battery](#).
2. Install the [base cover](#).
3. Follow the procedure in [After working inside your computer](#).

I/O board

Removing the I/O board

CAUTION: The information in this section is intended for authorized service technicians only.

Prerequisites

1. Follow the procedure in [Before working inside your computer](#).
2. Remove the [base cover](#).

About this task

The following images indicate the location of the I/O board and provide a visual representation of the removal procedure.

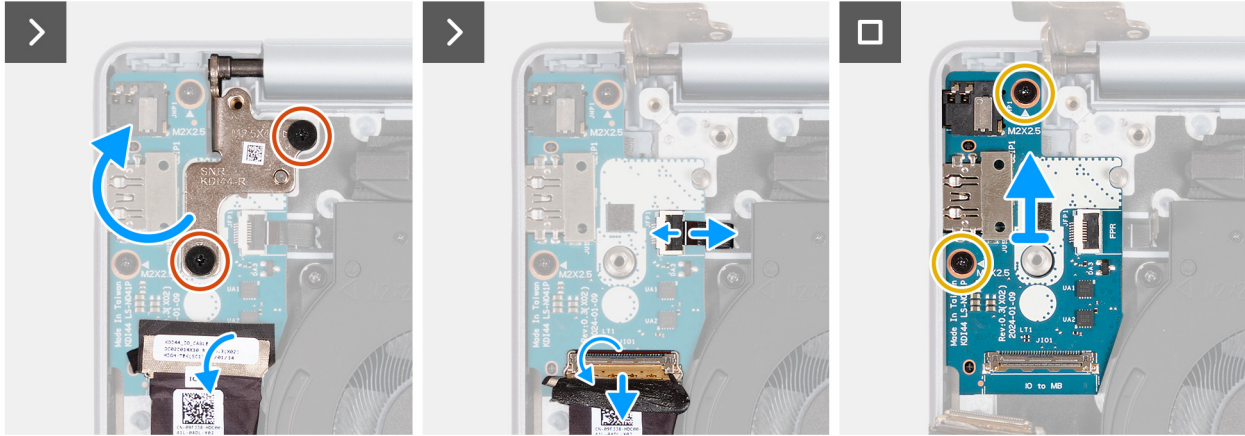
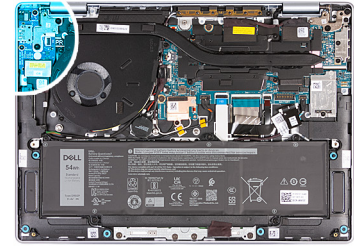
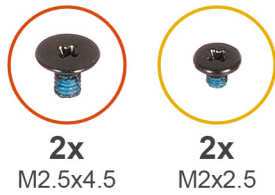

Figure 39. Removing the I/O board

Steps

1. Remove the two screws (M2.5x4.5) that secure the right display hinge to the palm-rest and keyboard assembly.
2. Lift and open the right display hinge to an angle of 90 degrees from the palm-rest and keyboard assembly to access the I/O board.
3. Peel the tape that secures the I/O board cable to the connector (IO to MB) on the I/O board.
4. Open the latch and disconnect the I/O board cable from the connector (IO to MB) on the I/O board.
5. For computers shipped with a fingerprint reader installed, open the latch and disconnect the fingerprint reader cable from the connector (FPR) on the I/O board.
6. Remove the two screws (M2x2.5) that secure the I/O board to the palm-rest and keyboard assembly.
7. Carefully slide and lift the I/O board at an angle, moving it away from the port slots, and then remove it from the palm-rest and keyboard assembly.

NOTE: Ensure that the power button is not displaced while removing the I/O board.

Installing the I/O board

CAUTION: The information in this section is intended for authorized service technicians only.

Prerequisites

If you are replacing a component, remove the existing component before performing the installation procedure.

About this task

The following images indicate the location of the I/O board and provide a visual representation of the installation procedure.

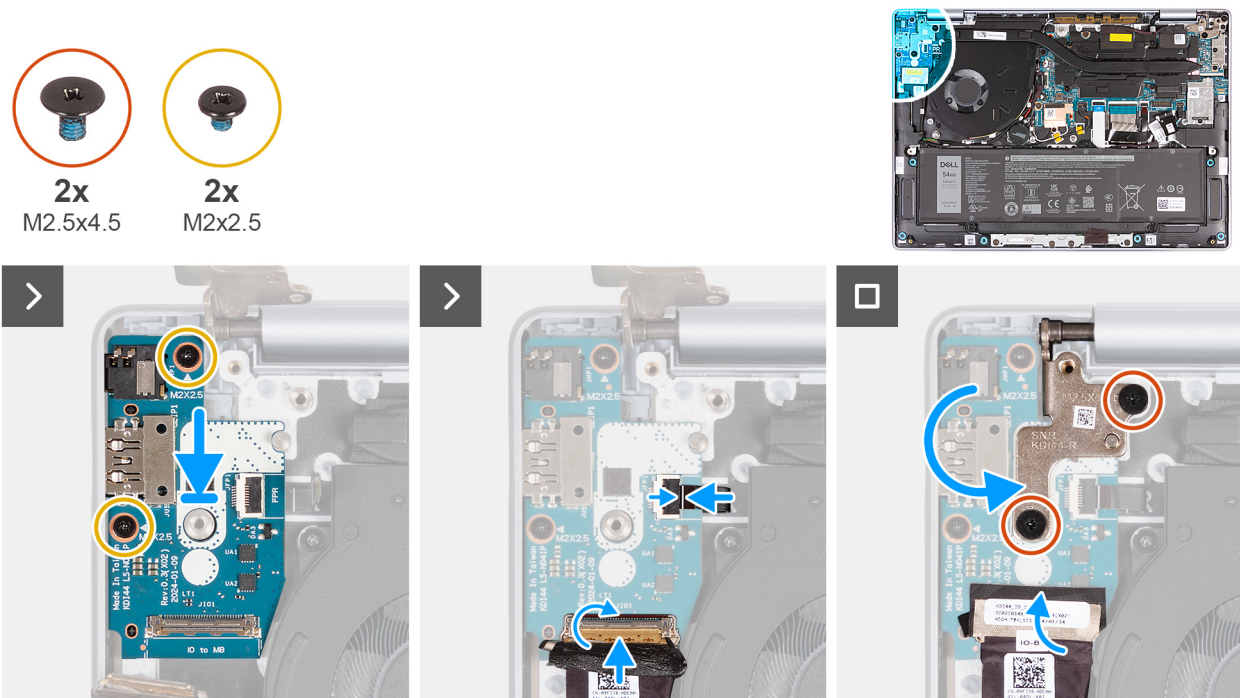

Figure 40. Installing the I/O board

Steps

1. Carefully slide and place the I/O board on the palm-rest and keyboard assembly.
2. Align the ports on the I/O board with the port slots on the palm-rest and keyboard assembly.
3. Replace the two screws (M2x2.5) that secure the I/O board to the palm-rest and keyboard assembly.
4. For computers shipped with a fingerprint reader installed, connect the fingerprint reader cable to the connector (FPR) on the I/O board and close the latch to secure the cable in place.
5. Connect the I/O board cable to the connector (IO to MB) on the I/O board and close the latch to secure the cable in place.
6. Adhere the tape to secure the I/O board cable to the connector (IO to MB) on the I/O board.
7. Close the right display hinge downwards to align the screw holes of the right display hinge with the screw holes on the palm-rest and keyboard assembly.
8. Replace the two screws (M2.5x4.5) that secure the right display hinge to the palm-rest and keyboard assembly.

Next steps

1. Install the [base cover](#).
2. Follow the procedure in [After working inside your computer](#).

I/O-board cable

Removing the I/O-board cable

CAUTION: The information in this section is intended for authorized service technicians only.

Prerequisites

1. Follow the procedure in [Before working inside your computer](#).
2. Remove the [base cover](#).

About this task

The following images indicate the location of the I/O-board cable and provide a visual representation of the removal procedure.

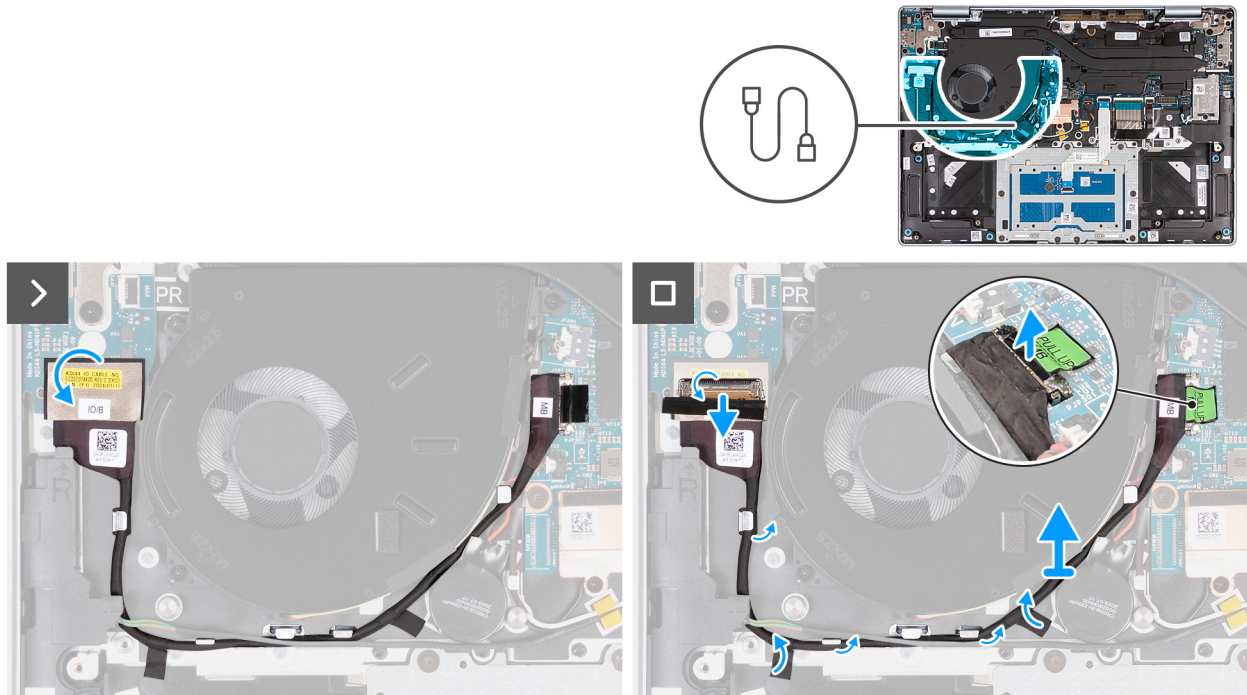

Figure 41. Removing the I/O-board cable

Steps

1. Peel the tape that secures the I/O-board cable to the connector (IO to MB) on the I/O board.
2. Open the latch and disconnect the I/O-board cable from the connector (IO to MB) on the I/O board.
3. Remove the I/O-board cable from the routing guides on the palm-rest and keyboard assembly.

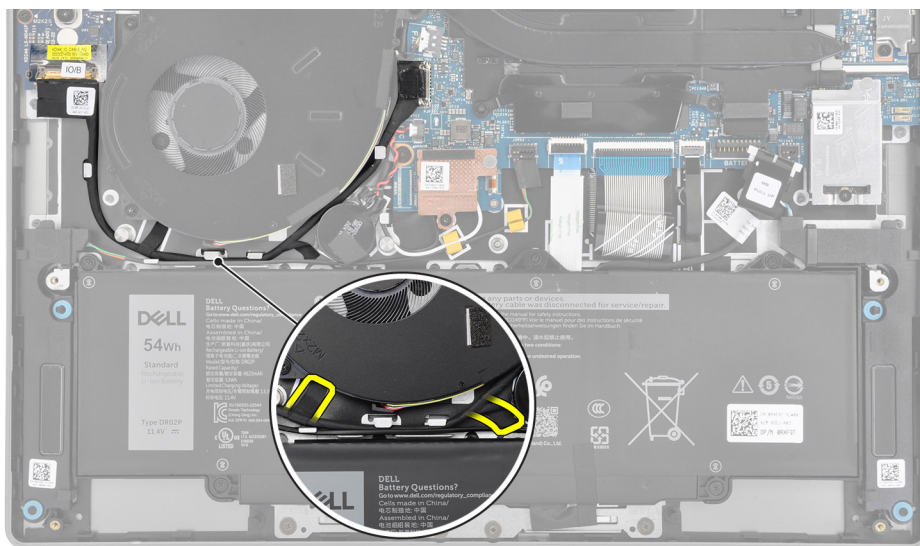

Figure 42. I/O-board cable routing

NOTE: The I/O-board cable is routed over the coin-cell battery cable and the antenna cables. The cable then routes along the top-left side of the battery, bottom-right side of the fan, and secured in place by two pieces of tape.

4. Peel the tape and disconnect the I/O-board cable from the connector (IO BOARD) on the system board.

Installing the I/O-board cable

CAUTION: The information in this section is intended for authorized service technicians only.

Prerequisites

If you are replacing a component, remove the existing component before performing the installation procedure.

About this task

The following images indicate the location of the I/O-board cable and provide a visual representation of the installation procedure.

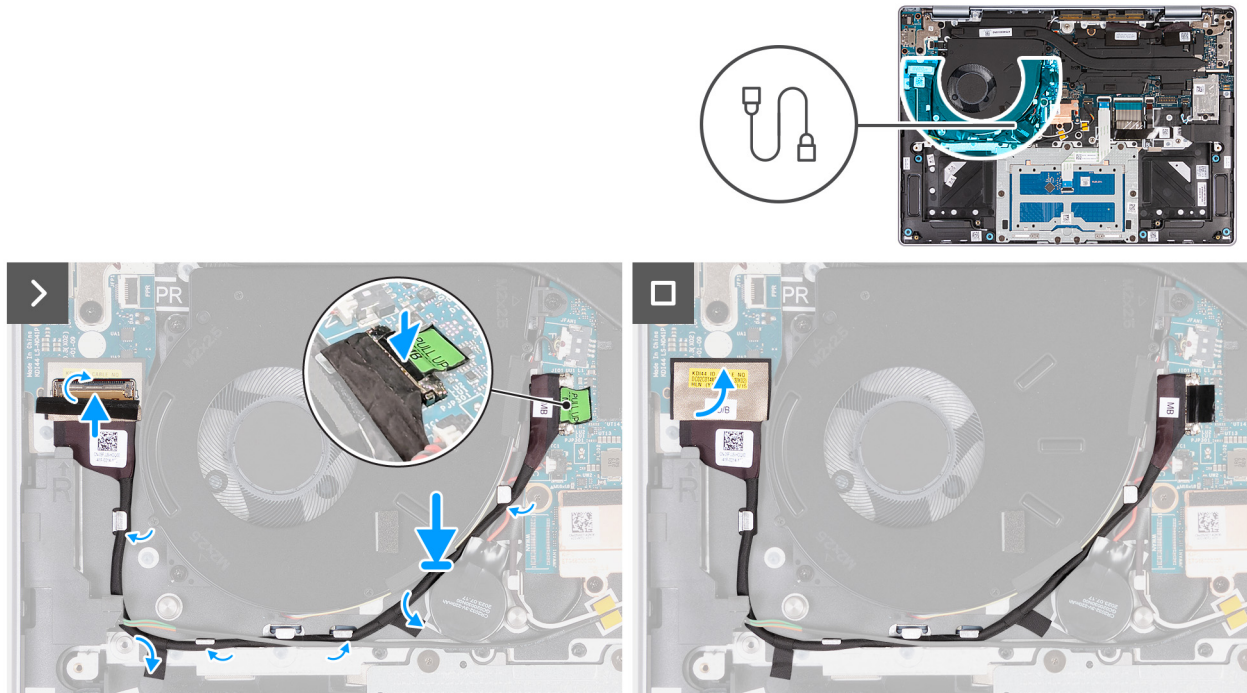

Figure 43. Installing the I/O-board cable

Steps

1. Connect the I/O-board cable to the connector (IO to MB) on the I/O board and close the latch to secure the cable in place.
2. Route the I/O-board cable through the routing guides on the palm-rest and keyboard assembly.

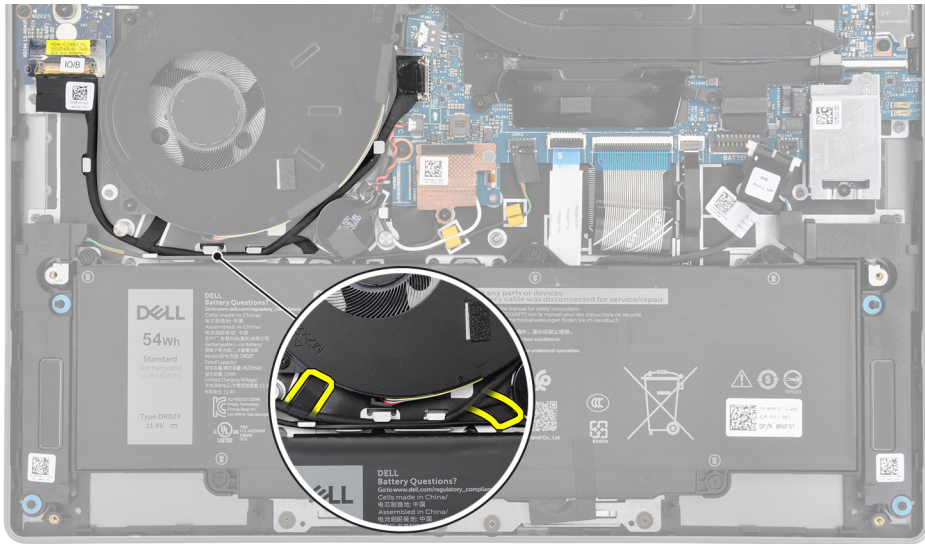

Figure 44. I/O-board cable routing

NOTE: The I/O-board cable is routed over the coin-cell battery cable and antenna cables. The cable then routes along the top-left side of the battery, bottom-right side of the fan, and secured in place by two pieces of tape.

3. Adhere the tape and connect the I/O-board cable to the connector (IO BOARD) on the system board.
4. Adhere the tape to secure the I/O-board cable to the connector (IO to MB) on the I/O board.

Next steps

1. Install the [base cover](#).
2. Follow the procedure in [After working inside your computer](#).

Power button

Removing the power button

CAUTION: The information in this section is intended for authorized service technicians only.

Prerequisites

1. Follow the procedure in [Before working inside your computer](#).
2. Remove the [base cover](#).
3. Remove the [I/O board](#).

About this task

The following images indicate the location of the power button and provide a visual representation of the removal procedure.

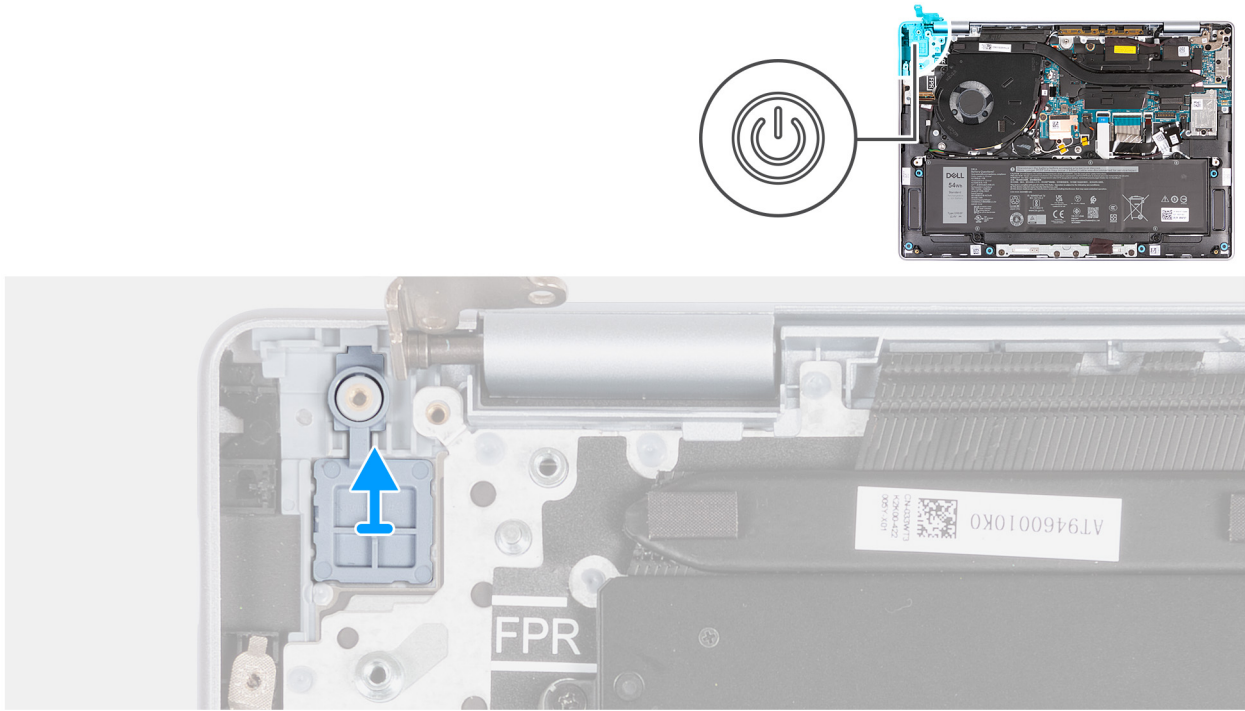

Figure 45. Removing the power button

Lift the power button off the palm-rest and keyboard assembly.

Installing the power button

CAUTION: The information in this section is intended for authorized service technicians only.

Prerequisites

If you are replacing a component, remove the existing component before performing the installation procedure.

About this task

The following images indicate the location of the power button and provide a visual representation of the installation procedure.

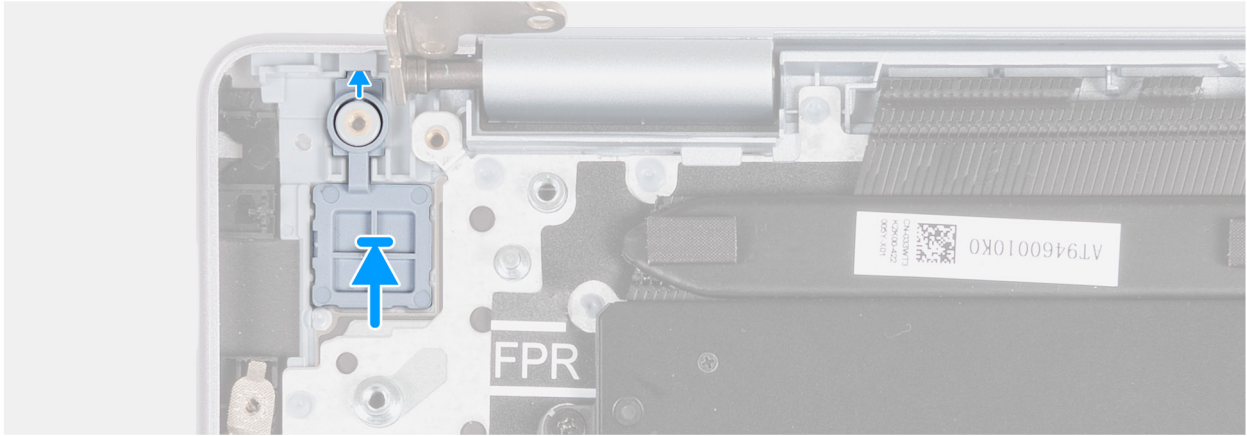
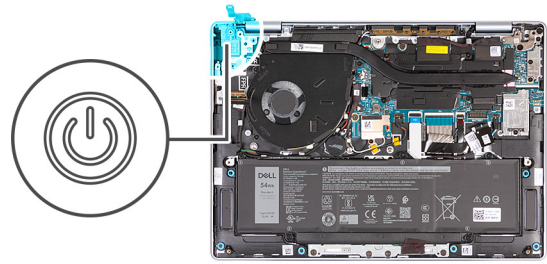

Figure 46. Installing the power button

Steps

1. Insert the tab on the power button into the slot on the palm-rest and keyboard assembly.

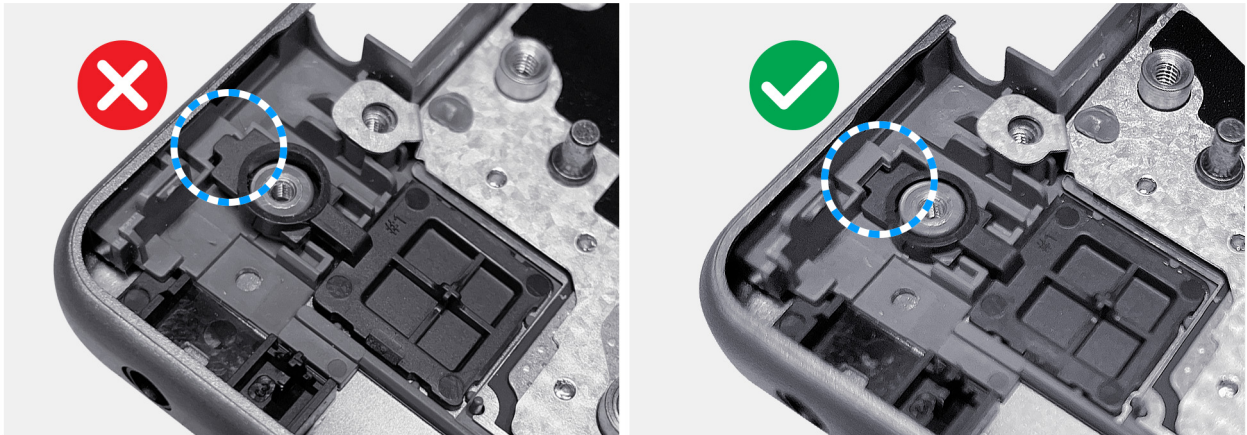

Figure 47. Power button

NOTE: The tab must be inserted inside the slot and not on top of it to avoid creating a gap which may damage the I/O board or the base cover.

2. Using the alignment post, place the power button on its slot on the palm-rest and keyboard assembly.

Next steps

1. Install the [I/O board](#).
2. Install the [base cover](#).
3. Follow the procedure in [After working inside your computer](#).

Power button with optional fingerprint reader

Removing the power button with optional fingerprint reader

CAUTION: The information in this section is intended for authorized service technicians only.

Prerequisites

1. Follow the procedure in [Before working inside your computer](#).
2. Remove the [base cover](#).
3. Remove the [I/O board](#).

About this task

NOTE: This procedure applies only to computers shipped with a power button with fingerprint reader installed.

The following images indicate the location of the power button with fingerprint reader and provide a visual representation of the removal procedure.

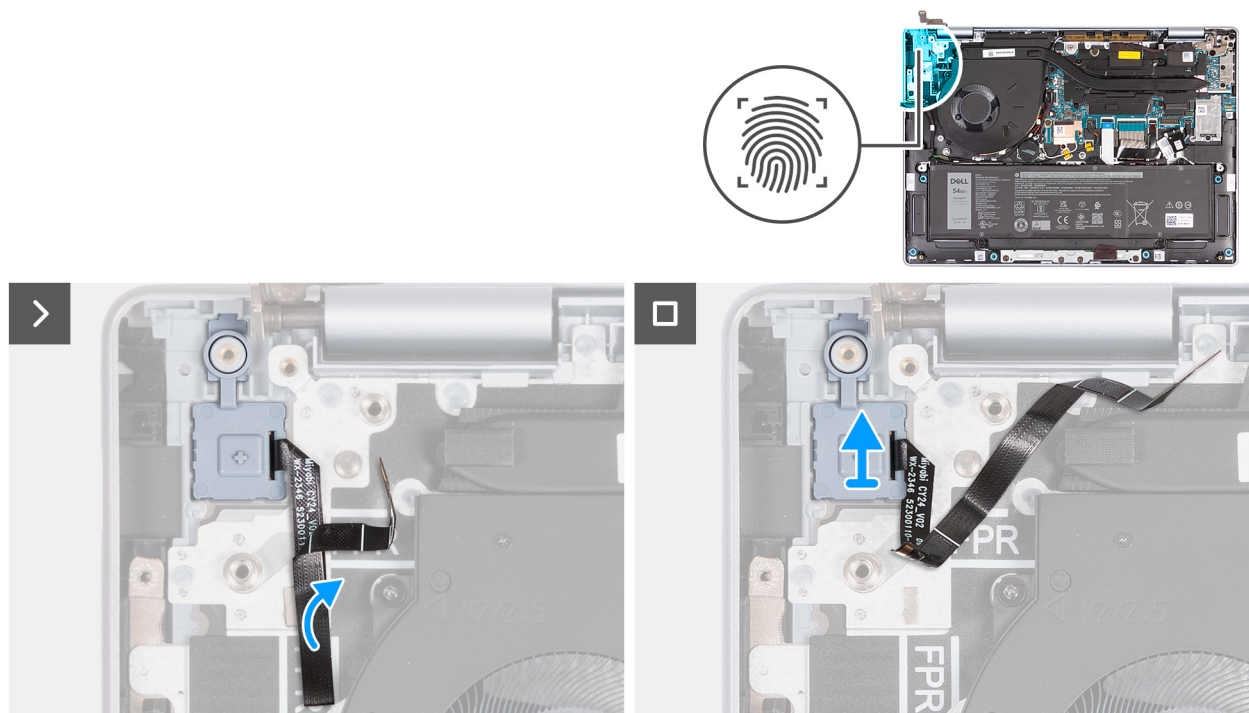

Figure 48. Removing the power button with optional fingerprint reader

Steps

1. Peel the fingerprint reader cable from the palm-rest and keyboard assembly.
2. Lift the power button with fingerprint reader cable off the slot on the palm-rest and keyboard assembly.

Installing the power button with optional fingerprint reader

CAUTION: The information in this section is intended for authorized service technicians only.

Prerequisites

If you are replacing a component, remove the existing component before performing the installation procedure.

About this task

NOTE: This procedure applies only to computers shipped with a power button with fingerprint reader installed.

The following images indicate the location of the power button with the optional fingerprint reader and provide a visual representation of the installation procedure.

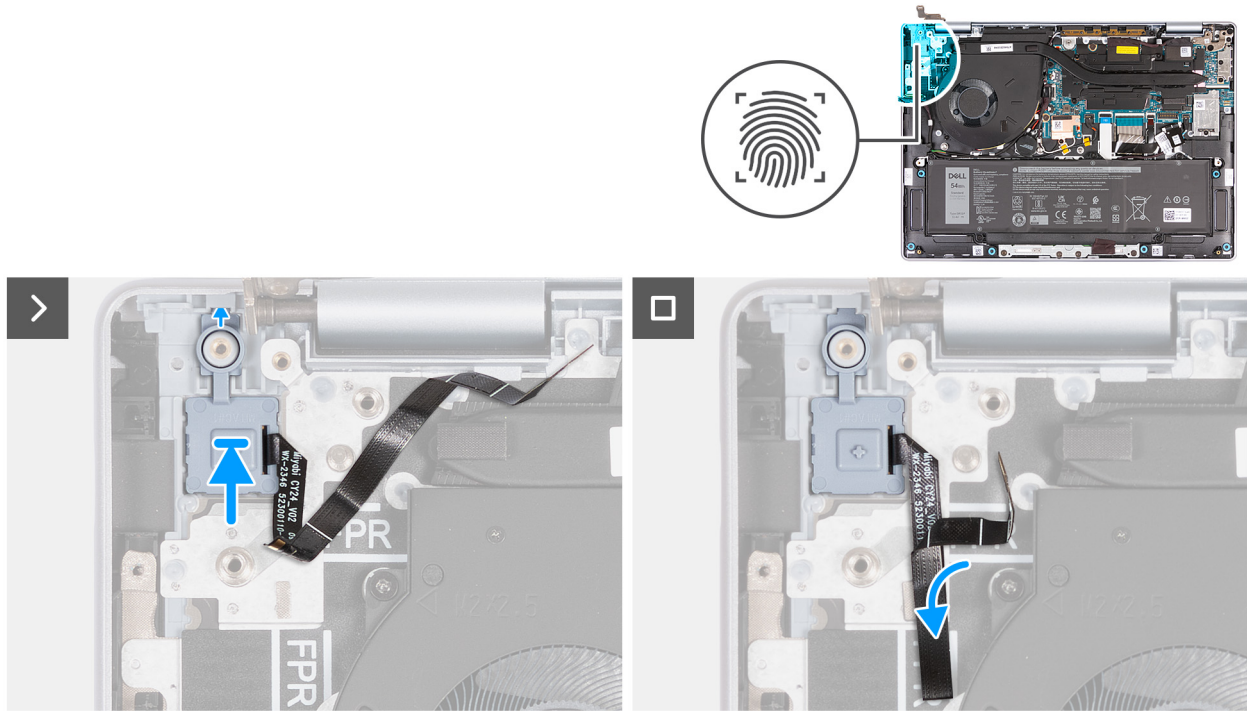

Figure 49. Installing the power button with optional fingerprint reader

Steps

1. Insert the tab on the power button with fingerprint reader into the slot on the palm-rest and keyboard assembly.

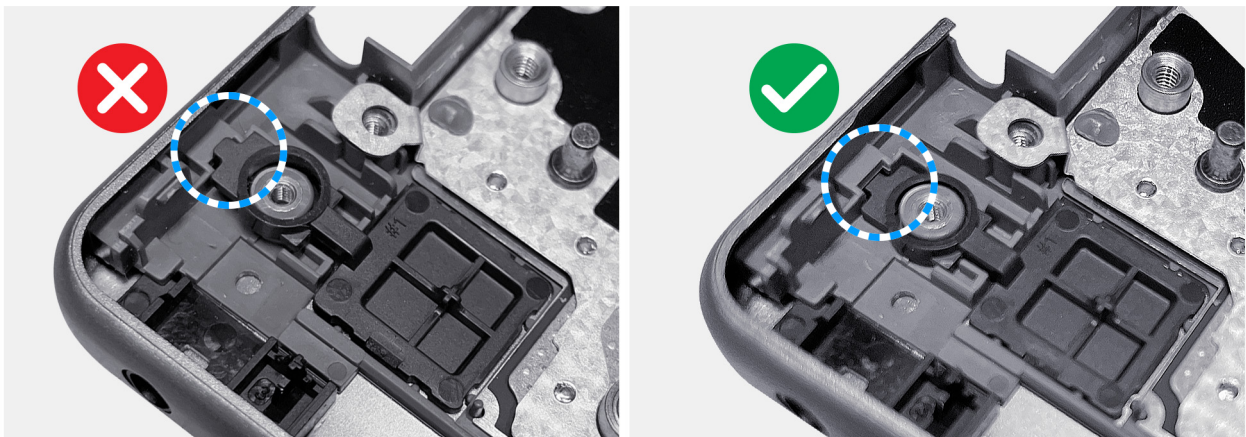



Figure 50. Power button

NOTE: The tab must be inserted inside the slot and not on top of it to avoid creating a gap which may damage the I/O board or the base cover.

2. Using the alignment post, place the power button with fingerprint reader cable into the slot on the palm-rest and keyboard assembly.
3. Adhere the fingerprint reader cable to the palm-rest and keyboard assembly.

 **NOTE:** When installing the power button with fingerprint reader, align the fingerprint reader cable along the etched marking on the palm-rest and keyboard assembly.

Next steps

1. Install the [I/O board](#).
2. Install the [base cover](#).
3. Follow the procedure in [After working inside your computer](#).

Antennas

Removing the antennas

 **CAUTION:** The information in this removal section is intended for authorized service technicians only.

Prerequisites

1. Follow the procedure in [Before working inside your computer](#).
2. Remove the [base cover](#).
3. Remove the [fan](#).

About this task

The following images indicate the location of the antennas and provide a visual representation of the removal procedure.



2x
M2x2.5

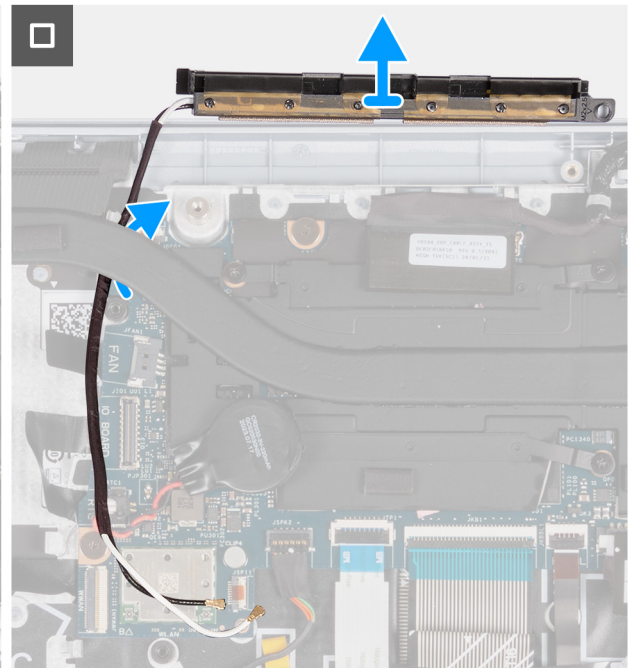
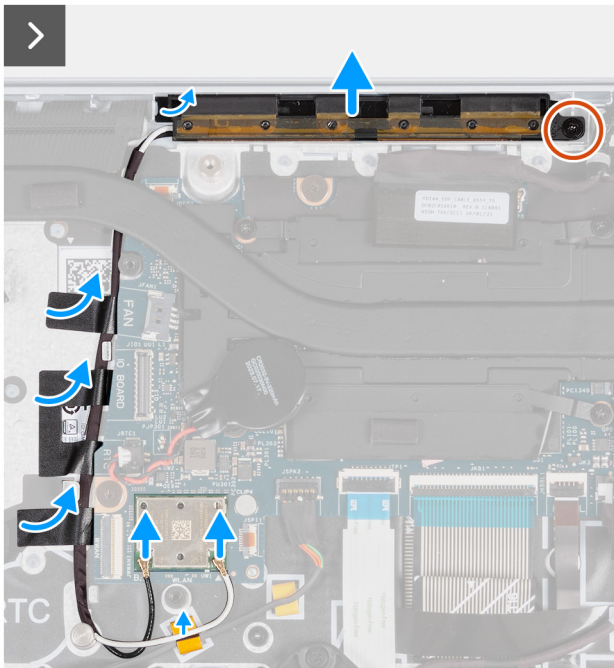
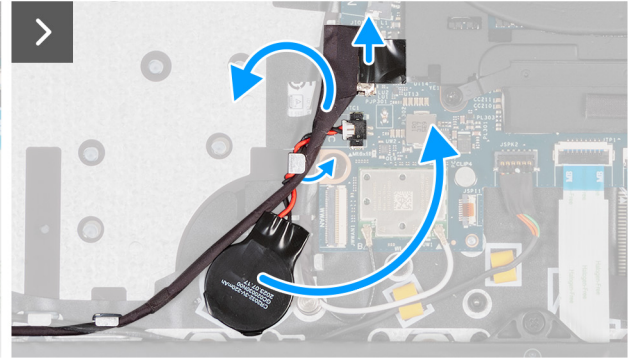
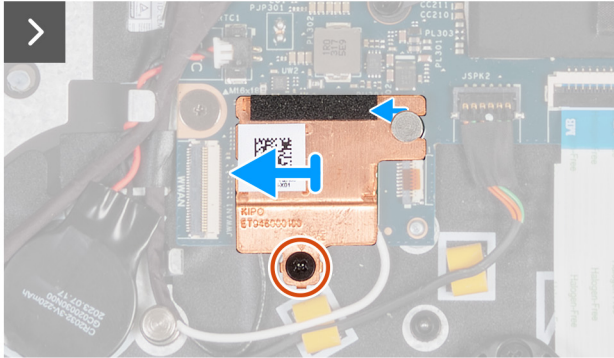
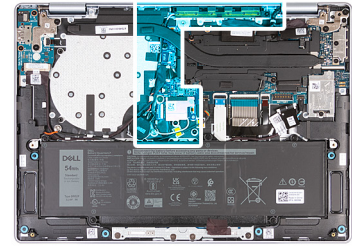

Figure 51. Removing the antennas

Steps

1. Remove the screw (M2x2.5) that secures the wireless card thermal plate to the palm-rest and keyboard assembly.
2. Disconnect the I/O-board cable from the connector (IO BOARD) on the system board.
3. Remove the I/O-board cable from the routing guide over the antenna cables on the palm-rest and keyboard assembly.
4. Move the coin-cell battery along with cable from the routing guide on the palm-rest and keyboard assembly.
5. Remove the antenna cables from the wireless card.
6. Peel the tapes that secure the antenna cables to the palm-rest and keyboard assembly.
7. Remove the screw (M2x2.5) that secures the left and the right antennas to the palm-rest and keyboard assembly.
8. Remove the antenna cables from the routing guides on the palm-rest and keyboard assembly.

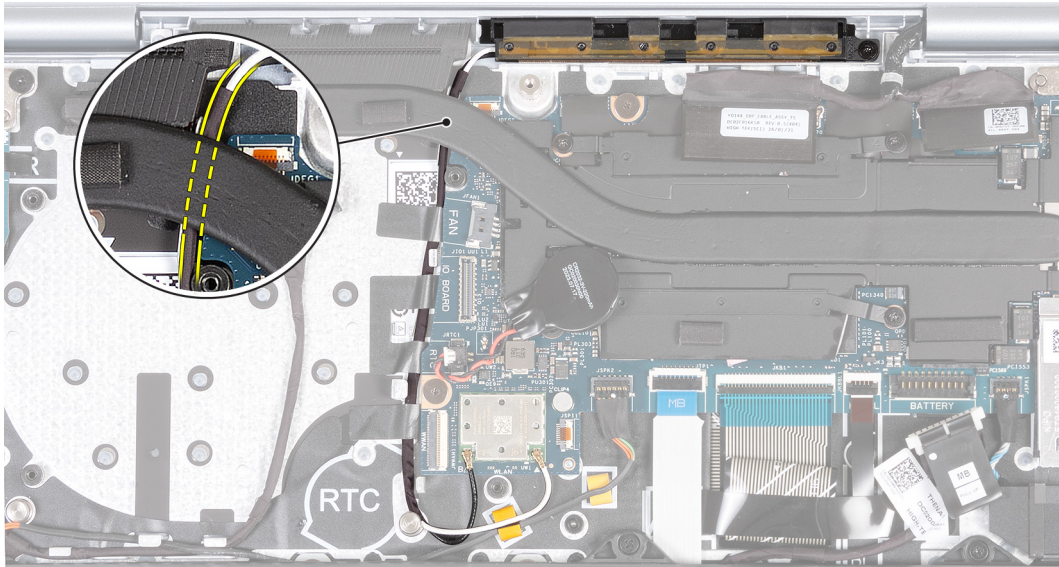

Figure 52. Removing antenna cables

NOTE: Ensure to carefully remove the antenna cables from the routing guides underneath the heat sink.

9. Lift the left and the right antennas, along with the antenna cables, off the palm-rest and keyboard assembly.

Installing the antennas

CAUTION: The information in this installation section is intended for authorized service technicians only.

Prerequisites

If you are replacing a component, remove the existing component before performing the installation process.

About this task

The following images indicate the location of the antennas and provide a visual representation of the installation procedure.



2x
M2x2.5

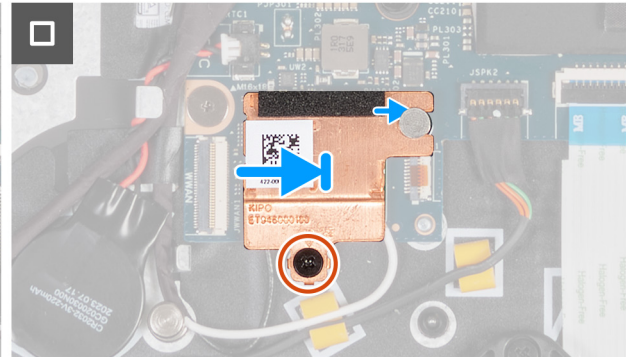
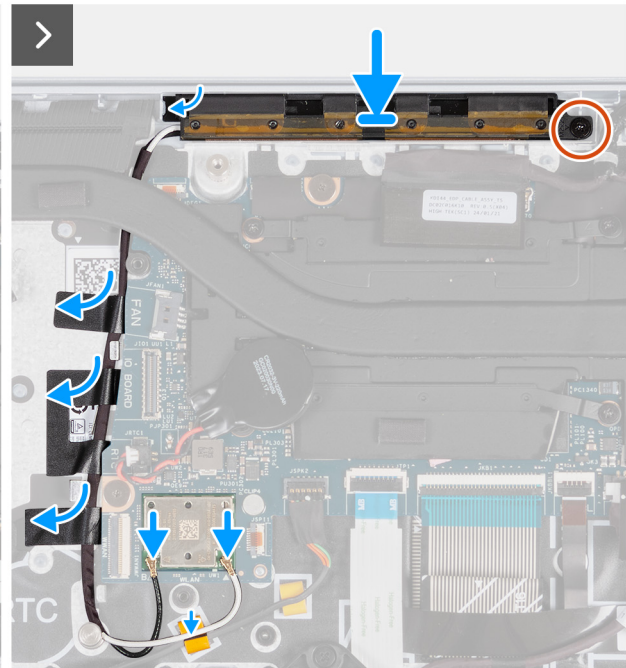
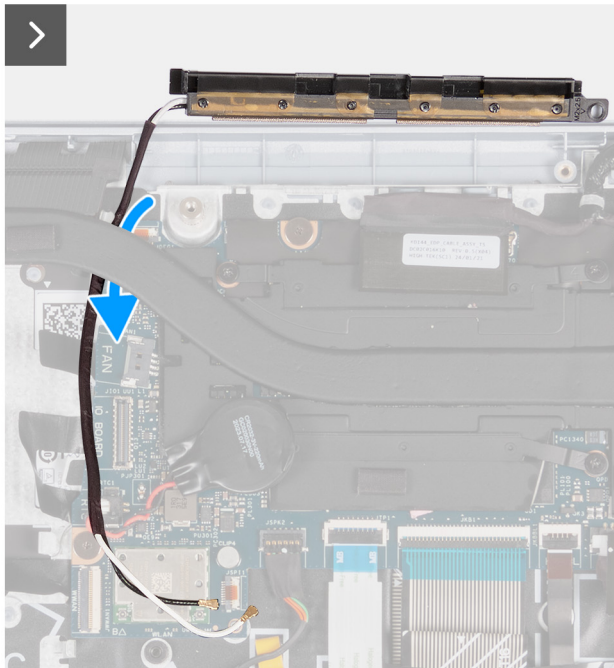
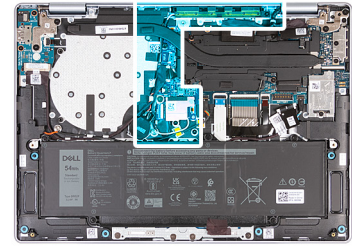

Figure 53. Installing the antennas

Steps

1. Align and place the left and the right antennas on the slot on the palm-rest and keyboard assembly.
2. Replace the screw (M2x2.5) that secures the left and the right antennas to the palm-rest and keyboard assembly.
3. Route the antenna cables onto the routing guides on the palm-rest and keyboard assembly.

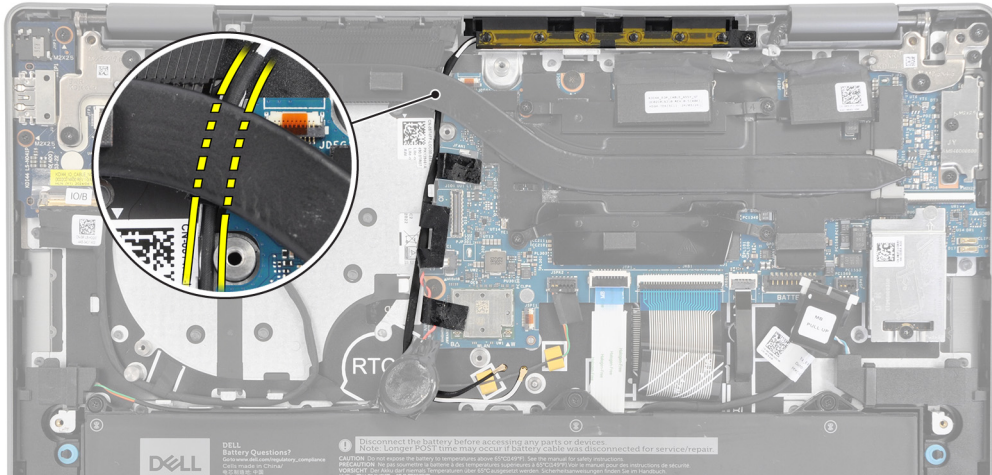

Figure 54. Installing antenna cables

NOTE: Ensure to carefully route the antenna cables onto the routing guides underneath the heat sink.

4. Adhere the tapes that secure the antenna cables to the palm-rest and keyboard assembly.
5. Connect the antenna cables to the wireless card.

NOTE: Ensure to connect the antenna cables to the wireless card as per the cable color scheme.

Table 27. Antenna-cable color scheme

Connector on the wireless card	Antenna-cable color	Silkscreen marking
Main	White	W
Auxiliary	Black	B

6. Move and adhere the coin-cell battery and route the coin-cell battery cable through the routing guide on the palm-rest and keyboard assembly.
7. Route the I/O-board cable through the routing guide on the palm-rest and keyboard assembly.
8. Connect the I/O-board cable to the connector (IO BOARD) on the system board.
9. Align the notch on the wireless card thermal plate with the tab on the system board.

NOTE: The wireless card thermal plate includes a thermal pad attached below. Ensure to adhere the thermal pad back to its location if it is displaced during removal procedure.

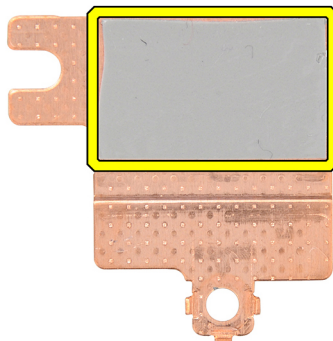

Figure 55. Thermal pad

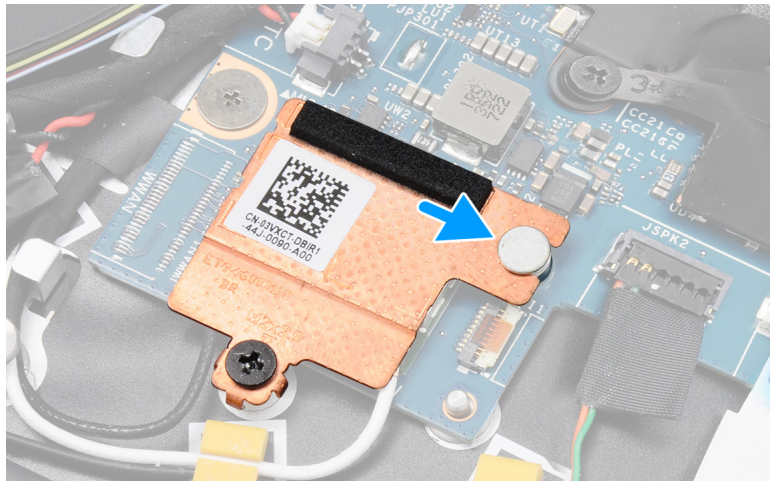

Figure 56. Installing wireless card thermal plate

10. Replace the screw (M2x2.5) that secures the wireless card thermal plate to the palm-rest and keyboard assembly.

Next steps

1. Install the [fan](#).
2. Install the [base cover](#).
3. Follow the procedure in [After working inside your computer](#).

System board

Removing the system board

CAUTION: The information in this section is intended for authorized service technicians only.

Prerequisites

1. Follow the procedure in [Before working inside your computer](#).
2. Remove the [base cover](#).
3. Remove the [solid state drive](#).
4. Remove the [fan](#).
5. Remove the [heat sink](#).

NOTE: The system board can be removed and installed with the heat sink still attached to it. By keeping the heat sink attached to the system board, the thermal adhesive remains intact, thus preserving the thermal dissipation.

6. Remove the [display assembly](#).

About this task

The following image indicates the connectors on your system board.

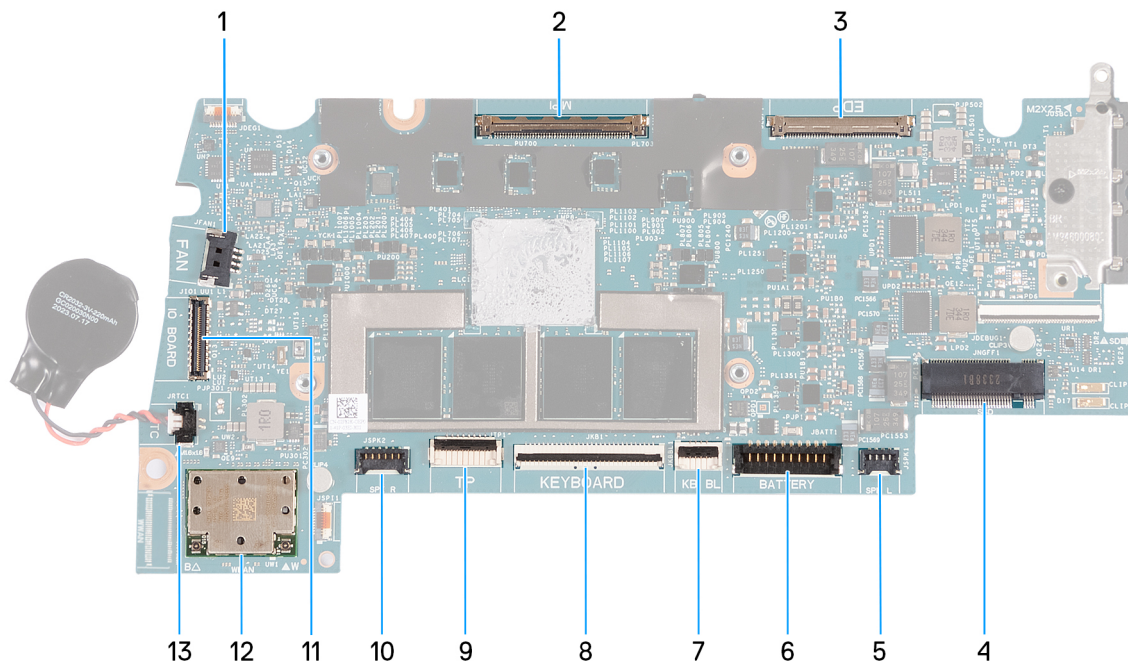

Figure 57. System board connectors

1. Fan cable (FAN) connector
2. Camera cable (MIPI) connector
3. Display cable (EDP) connector
4. Solid state drive (SSD) connector
5. Left speaker cable (SPK L) connector
6. Battery cable (BATTERY) connector
7. Keyboard-backlight cable (KB BL) connector (optional)
8. Keyboard cable (KEYBOARD) connector
9. Touchpad cable (TP) connector
10. Right speaker cable (SPK R) connector
11. I/O-board cable (IO) connector
12. Wireless card (WLAN) connector
13. Coin-cell battery cable (RTC) connector

The following images indicate the location of the system board and provide a visual representation of the removal procedure.

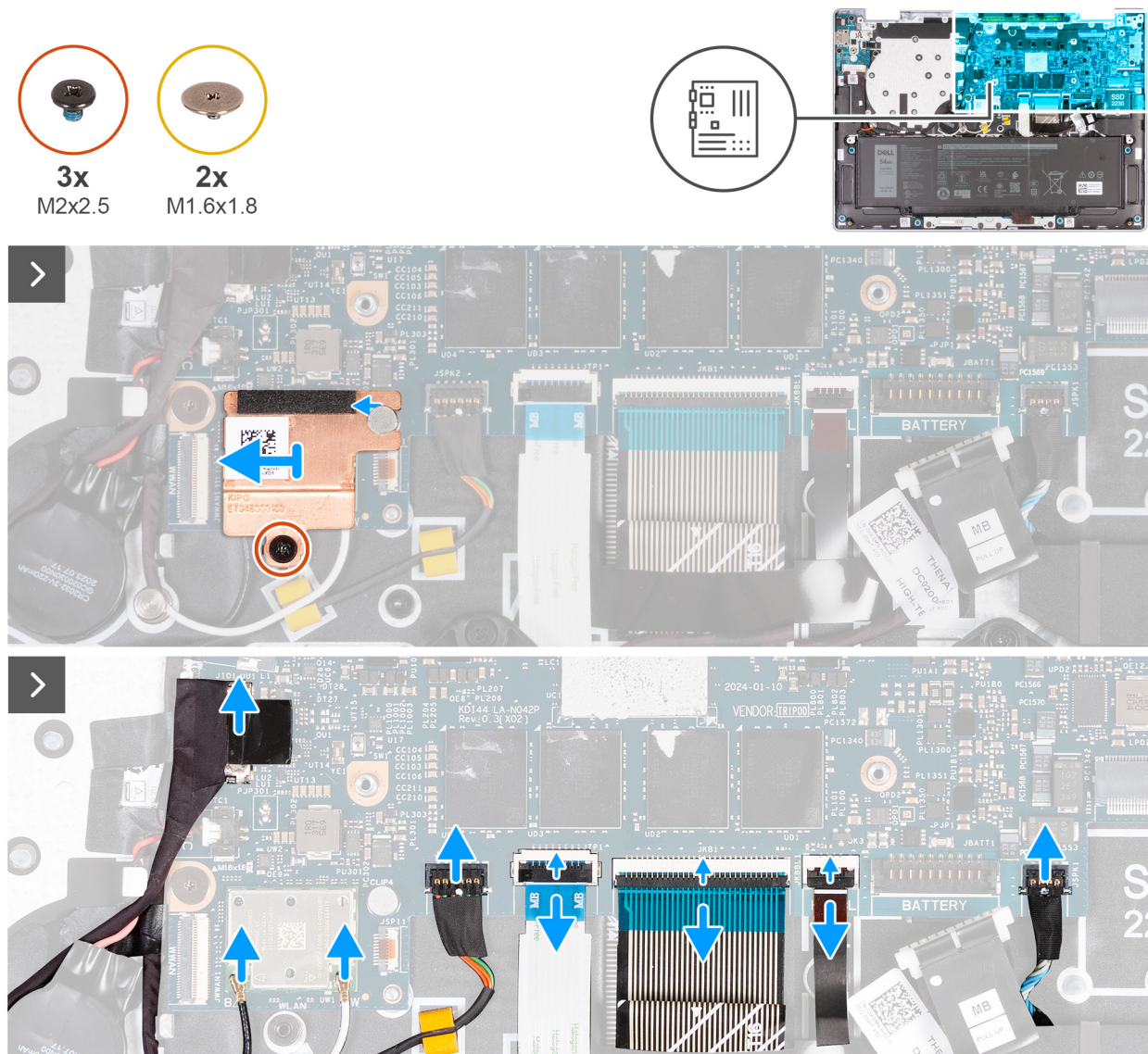

Figure 58. Disconnecting the cables

Steps

1. Remove the screw (M2x2.5) that secures the wireless card thermal plate to the palm-rest and keyboard assembly.
2. Remove the wireless card thermal plate off the wireless card.
3. Disconnect the following cables on the system board:
 - a. I/O-board cable (IO)
 - b. antenna cables
 - c. right speaker cable (SPK R)
 - d. touchpad cable (TP)
 - e. keyboard cable (KEYBOARD)
 - f. keyboard-backlight cable (KB BL) (optional)
 - g. left speaker cable (SPK L)

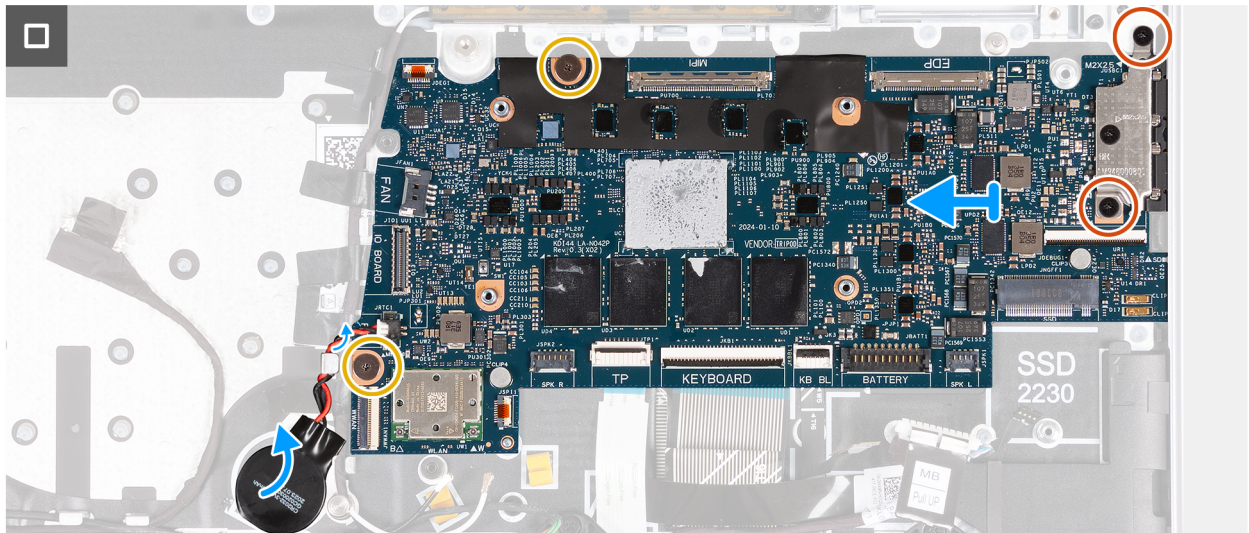
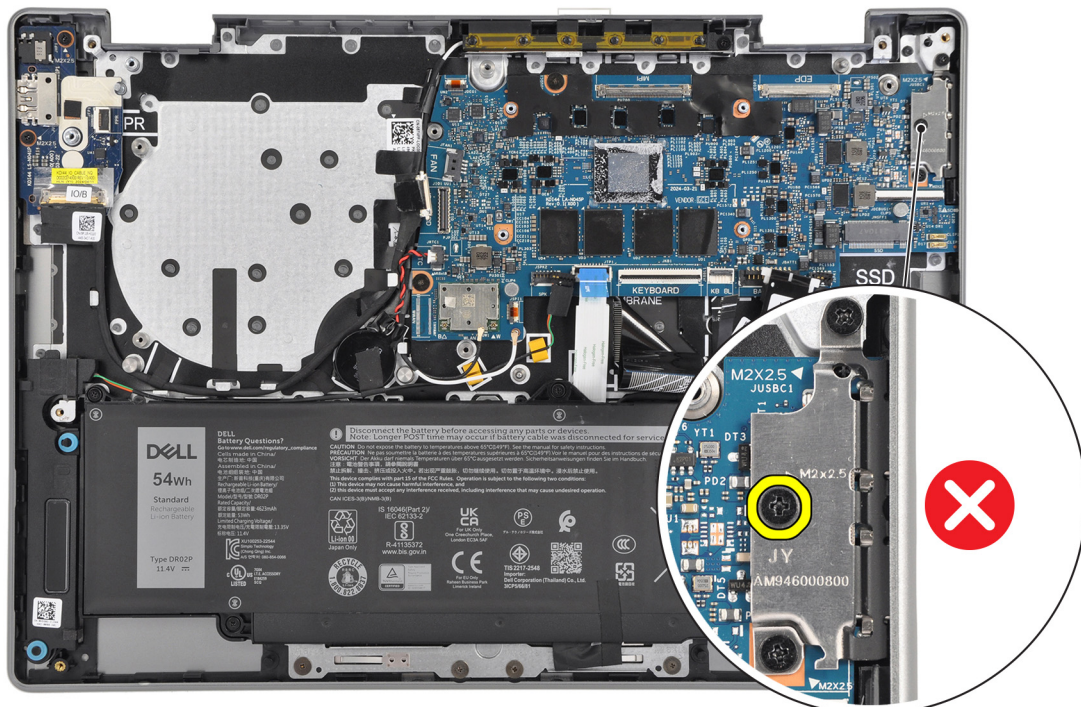

Figure 59. Removing the system board

4. Remove the two screws (M1.6x1.8) that secure the system board to the palm-rest and keyboard assembly.
5. Remove the two screws (M2x2.5) that secure the USB Type-C bracket to the palm-rest and keyboard assembly.
6. Pry the coin-cell battery from its slot on the palm-rest and keyboard assembly.
7. Slide and remove the system board off the port slots on the palm-rest and keyboard assembly.
8. Remove the system board along with the coin-cell battery and USB Type-C bracket off the palm-rest and keyboard assembly.

NOTE: Ensure not to remove the (M2x2.5) screw that secures the USB Type-C bracket to the system board.



Installing the system board

CAUTION: The information in this section is intended for authorized service technicians only.

Prerequisites

If you are replacing a component, remove the existing component before performing the installation procedure.

About this task

The following image indicates the connectors on your system board.

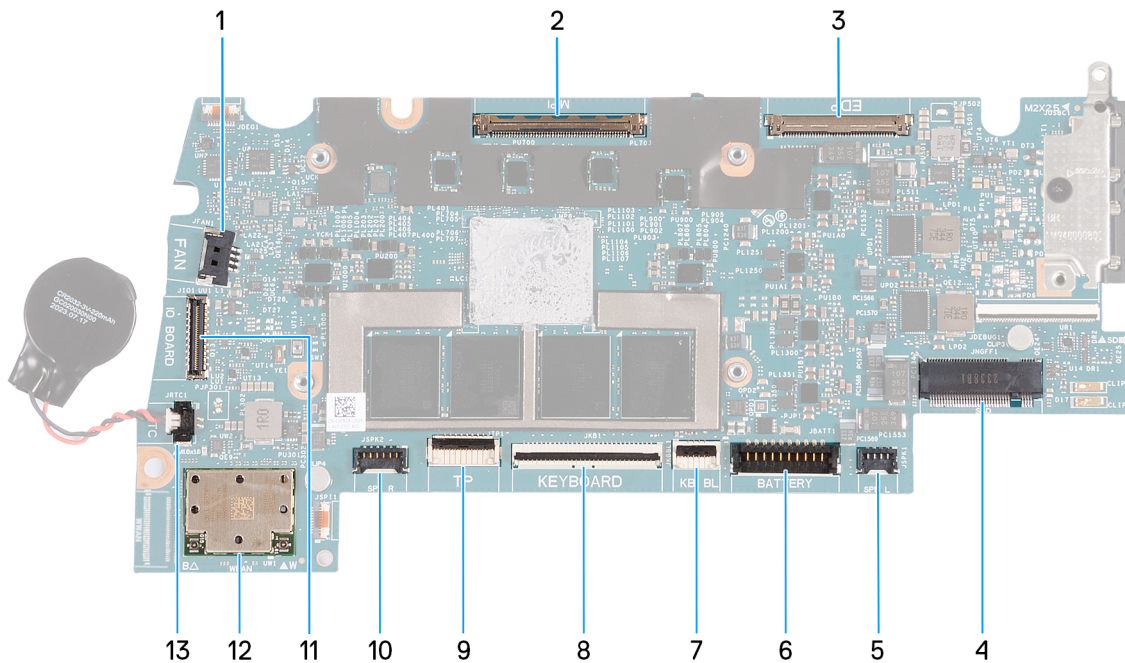

Figure 60. System board connectors

1. Fan cable (FAN) connector
2. Camera cable (MIPI) connector
3. Display cable (EDP) connector
4. Solid state drive (SSD) connector
5. Left speaker cable (SPK L) connector
6. Battery cable (BATTERY) connector
7. Keyboard-backlight cable (KB BL) connector (optional)
8. Keyboard cable (KEYBOARD) connector
9. Touchpad cable (TP) connector
10. Right speaker cable (SPK R) connector
11. I/O-board cable (IO) connector
12. Wireless card (WLAN) connector
13. Coin-cell battery cable (RTC) connector

The following images indicate the location of the system board and provide a visual representation of the installation procedure.

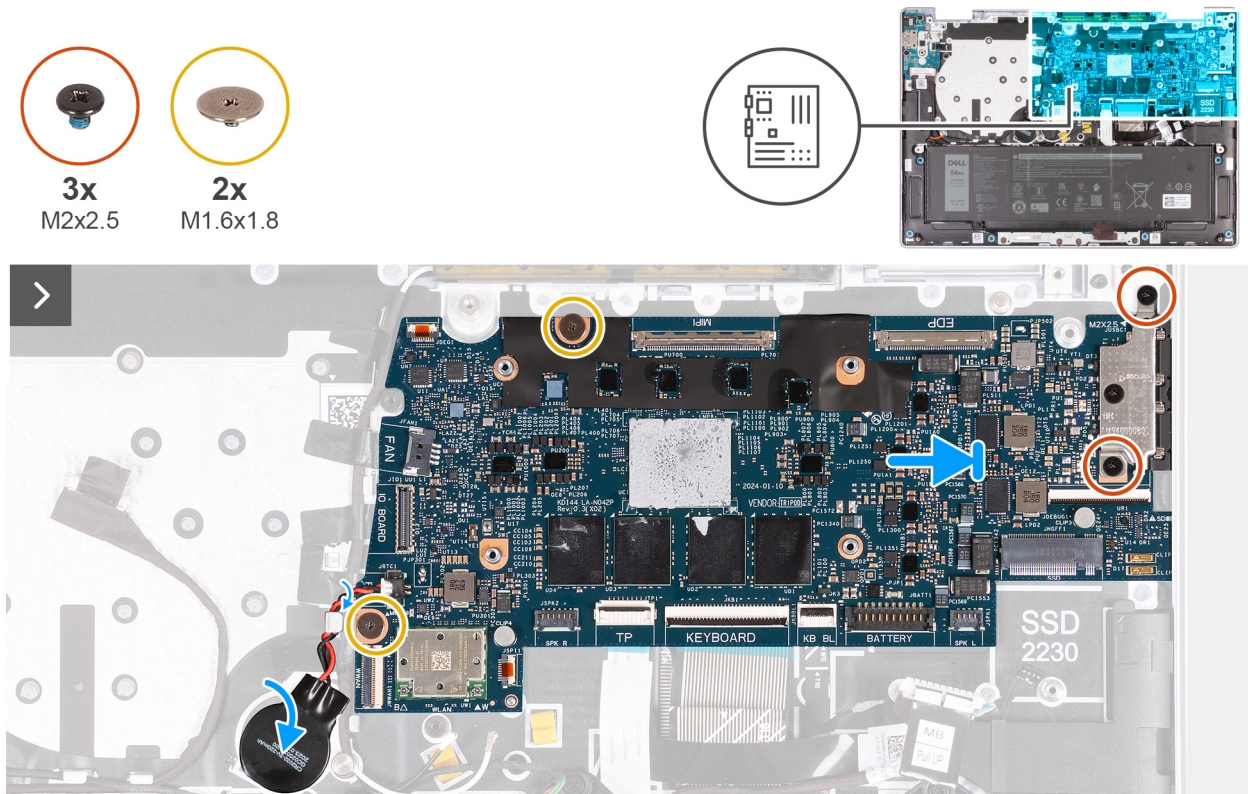

Figure 61. Installing the system board

Steps

1. Slide and place the system board on the palm-rest and keyboard assembly.
2. Align the ports on the system board with the port slots on the palm-rest and keyboard assembly.
3. Align the screw holes on the system board with the screw holes on the palm-rest and keyboard assembly.
4. Replace the two screws (M1.6x1.8) that secure the system board to the palm-rest and keyboard assembly.
5. Align the screw holes on the USB Type-C bracket with the screw holes on the palm-rest and keyboard assembly.
6. Replace the two screws (M2x2.5) that secure the USB Type-C bracket to the palm-rest and keyboard assembly.

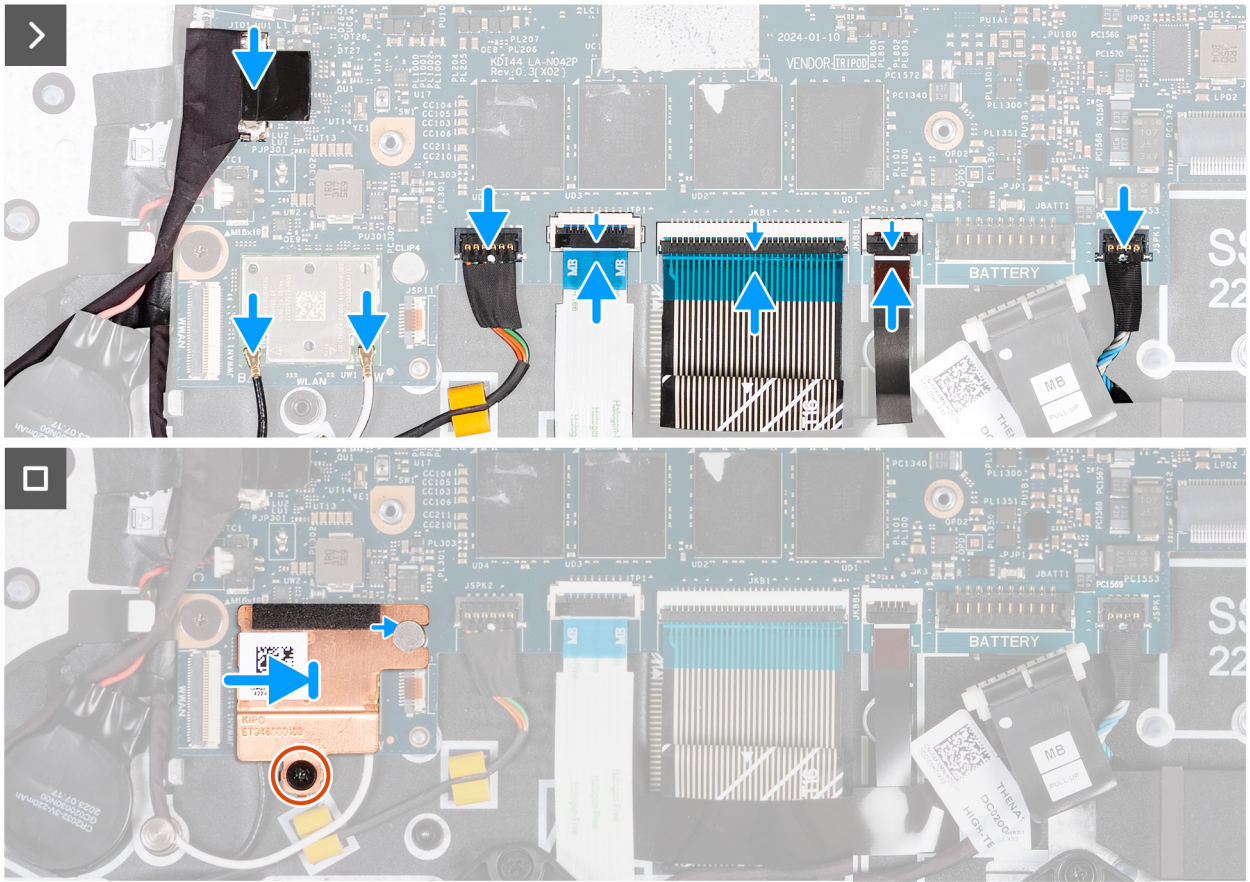

Figure 62. Connecting the cables

7. Adhere the coin-cell battery to its slot on the palm-rest and keyboard assembly.
8. Connect the following cables to the system board:
 - a. I/O-board cable (IO)
 - b. antenna cables

NOTE: Ensure to connect the antenna cables to the wireless card as per the cable color scheme.

Table 28. Antenna-cable color scheme

Connector on the wireless card	Antenna-cable color	Silkscreen marking
Main	White	W
Auxiliary	Black	B

- c. right speaker cable (SPK R)
- d. touchpad cable (TP)
- e. keyboard cable (KEYBOARD)
- f. keyboard-backlight cable (KB BL) (optional)
- g. left speaker cable (SPK L)
9. Align the screw hole on the wireless card thermal plate with the screw hole on the wireless card.
10. Replace the screw (M2x2.5) that secures the wireless card thermal plate to the palm-rest and keyboard assembly.

Next steps

1. Install the [display assembly](#).
2. Install the [heat sink](#).
3. Install the [fan](#).

4. Install the [solid state drive](#).
5. Install the [base cover](#).
6. Follow the procedure in [After working inside your computer](#).

Palm-rest and keyboard assembly

Removing the palm-rest and keyboard assembly

 **CAUTION:** The information in this section is intended for authorized service technicians only.

Prerequisites

1. Follow the procedure in [Before working inside your computer](#).
2. Remove the [base cover](#).
3. Remove the [battery](#)
4. Remove the [battery cable](#).
5. Remove the [touchpad](#).
6. Remove the [speakers](#).
7. Remove the [power button](#) or the [power button with optional fingerprint reader](#), whichever is applicable.
8. Remove the [solid state drive](#).
9. Remove the [I/O board](#).
10. Remove the [I/O board cable](#).
11. Remove the [fan](#).
12. Remove the [display assembly](#).
13. Remove the [coin-cell battery](#).
14. Remove the [antennas](#).
15. Remove the [system board](#).

 **NOTE:** The system board can be removed with the heat sink attached to it in order to simplify the procedure and preserve the thermal bond between the system board and heat sink.

About this task

 **NOTE:** The palm-rest and keyboard assembly cannot be further disassembled after all the components in the prerequisite steps have been removed. If the keyboard is malfunctioning and is required to be replaced, replace the entire palm-rest and keyboard assembly.

The image below shows the palm-rest and keyboard assembly after all the components in the prerequisite steps have been removed.

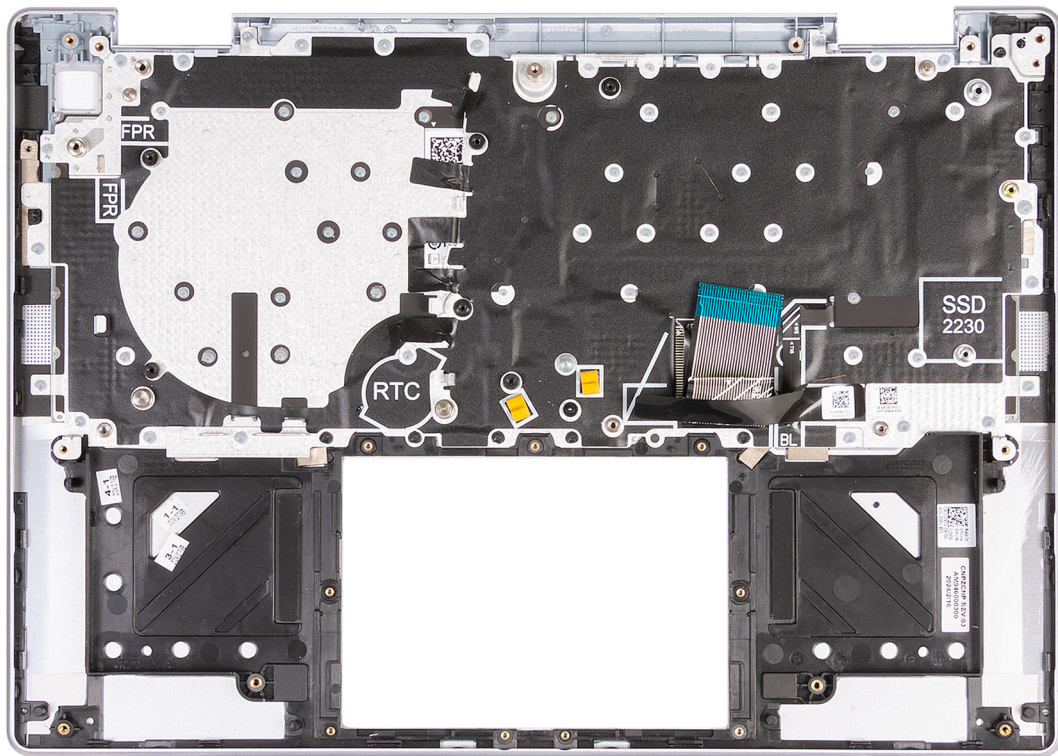

Figure 63. Removing the palm-rest and keyboard assembly

Installing the palm-rest and keyboard assembly

CAUTION: The information in this section is intended for authorized service technicians only.

Prerequisites

If you are replacing a component, remove the existing component before performing the installation procedure.

About this task

The following image shows the palm-rest and keyboard assembly before all the components in the post-requisites steps have been installed. Place the palm-rest and keyboard assembly on a flat surface.

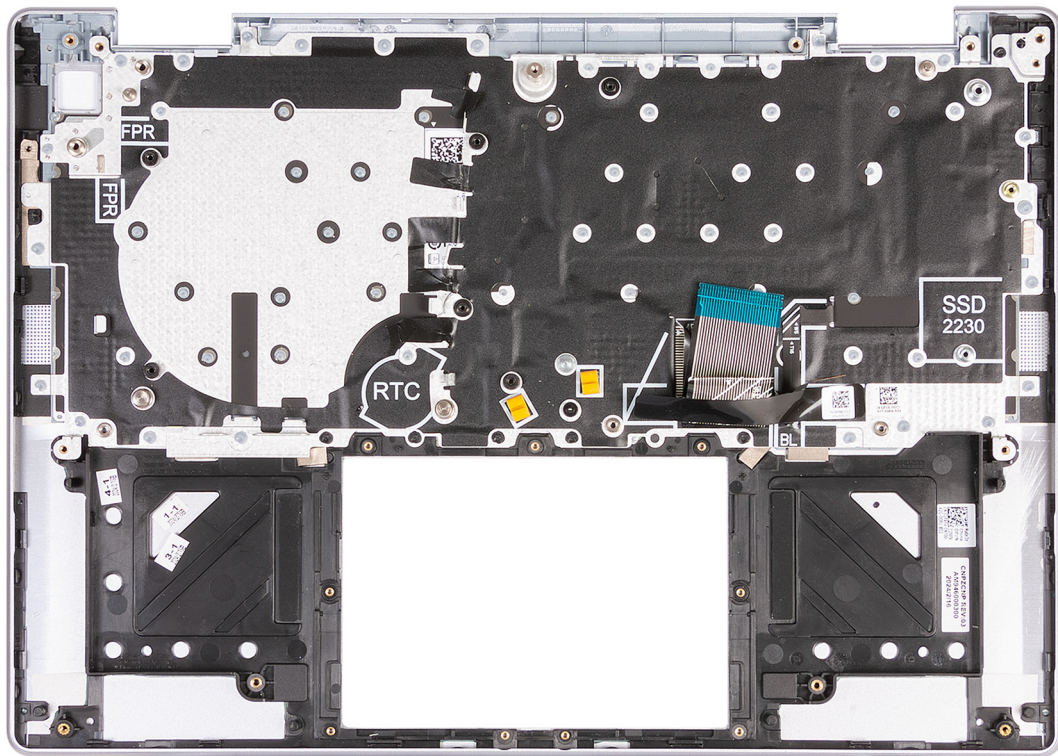

Figure 64. Installing the palm-rest and keyboard assembly

Next steps

1. Install the [system board](#).
2. Install the [antennas](#).
3. Install the [coin-cell battery](#).
4. Install the [display assembly](#).
5. Install the [fan](#).
6. Install the [I/O board cable](#).
7. Install the [I/O board](#).
8. Install the [solid state drive](#).
9. Install the [power button](#) or the [power button with optional fingerprint reader](#), whichever is applicable.
10. Install the [speakers](#).
11. Install the [touchpad](#).
12. Install the [battery cable](#).
13. Install the [battery](#).
14. Install the [base cover](#).
15. Follow the procedure in [After working inside your computer](#).

Software

This chapter details the supported operating systems along with instructions on how to install the drivers.

Operating system

Your Inspiron 14 5441 supports the following operating systems:

- Win 11 Home, ARM
- Win 11 Pro, ARM

Drivers and downloads

When troubleshooting, downloading, or installing drivers, it is recommended that you read the Dell Knowledge Base article [Drivers and Downloads FAQs 000123347](#).

BIOS Setup

NOTE: Depending on the computer and the installed devices, the options that are listed in this section may or may not be displayed.

CAUTION: Certain changes can make your computer work incorrectly. Before you change the settings in BIOS Setup, it is recommended that you note down the original settings for future reference.

Use BIOS Setup for the following purposes:

- Get information about the hardware installed in your computer, such as the amount of RAM and the capacity of the storage device.
- Change the system configuration information.
- Set or change a user-selectable option, such as the user password, type of storage device installed, and enable or disable base devices.

Entering BIOS Setup program

About this task

Turn on (or restart) your computer and press F2 immediately.

Navigation keys

NOTE: For most of the BIOS Setup options, changes that you make are recorded but do not take effect until you restart the computer.

Table 29. Navigation keys

Keys	Navigation
Up arrow	Moves to the previous field.
Down arrow	Moves to the next field.
Enter	Selects a value in the selected field (if applicable) or follows the link in the field.
Spacebar	Expands or collapses a drop-down list, if applicable.
Tab	Moves to the next focus area.
Esc	Moves to the previous page until you view the main screen. Pressing Esc in the main screen displays a message that prompts you to save any unsaved changes and restart the computer.

F12 One Time Boot menu

To enter the One Time Boot menu, turn on or restart your computer, and then press F12 immediately.

NOTE: If you are unable to enter the One Time Boot menu, repeat the above action.

The One Time Boot menu displays the devices that you can boot from and also display the options to start diagnostics. The boot menu options are:

- Removable Drive (if available)

- STXXXX Drive (if available)

 **NOTE:** XXX denotes the SATA drive number.

- Optical Drive (if available)
- SATA Hard Drive (if available)
- Diagnostics

The One Time Boot menu screen also displays the option to access BIOS Setup.

BIOS Setup options

 **NOTE:** Depending on your computer and its installed devices, the items that are listed in this section may or may not be displayed.

Table 30. BIOS Setup options—Overview menu

Overview	
Inspiron 14 5441	
BIOS Version	Displays the BIOS version number.
Service Tag	Displays the Service Tag of the computer.
Asset Tag	Displays the Asset Tag of the computer.
Manufacture Date	Displays the manufacture date of the computer.
Ownership Date	Displays the ownership date of the computer.
Express Service Code	Displays the Express Service Code of the computer.
Ownership Tag	Displays the Ownership Tag of the computer.
Signed Firmware Update	Displays whether the Signed Firmware Update is enabled on your computer. By default, the Signed Firmware Update option is enabled.
Battery	
Primary	Displays the primary battery of the computer.
Battery Level	Displays the battery level of the computer.
Battery State	Displays the battery state of the computer.
Health	Displays the battery health of the computer.
AC Adapter	Displays whether an AC adapter is connected. If connected, displays the type of AC adapter that is connected.
Processor	
Processor Type	Displays the processor type.
Maximum Clock Speed	Displays the maximum processor clock speed.
Current Clock Speed	Displays the current processor clock speed.
Core Count	Displays the number of cores on the processor.
Processor L2 Cache	Displays the processor L2 cache size.
64-Bit Technology	Displays whether 64-bit technology is used.
Memory	
Memory Installed	Displays the total memory installed on the computer.
Memory Available	Displays the total memory available on the computer.

Table 30. BIOS Setup options—Overview menu (continued)

Overview	
Memory Speed	Displays the memory speed.
Memory Channel Mode	Displays single or dual channel mode.
Memory Technology	Displays the technology that is used for the memory.
Devices	
Panel Type	Displays the type of display panel available on the computer.
Video Controller	Displays the type of video controller available on the computer.
Wi-Fi Device	Displays the wireless device information of the computer.
Native Resolution	Displays the native resolution of the computer.
Audio Controller	Displays the audio controller information of the computer.
Bluetooth Device	Displays the Bluetooth device information of the computer.

Table 31. BIOS Setup options—Boot Configuration menu



Boot Configuration	
Boot Sequence	
Boot Mode: UEFI only	Displays the boot mode of the computer.
Boot Sequence	Displays the boot sequence.
Secure Boot	
	Secure Boot is a method of guaranteeing the integrity of the boot path by performing additional validation of the operating system and PCI add-in cards. The computer stops booting to the operating system when a component is not authenticated during the boot process. Secure Boot can be enabled in BIOS setup or using management interfaces like Dell Command Configure, but can only be disabled from BIOS setup.
Enable Secure Boot	<p>Enables the computer to boot using only validated boot software.</p> <p>By default, the Enable Secure Boot option is disabled.</p> <p>For additional security, Dell Technologies recommends keeping the Secure Boot option enabled to ensure that the UEFI firmware validates the operating system during the boot process.</p> <p> NOTE: For Secure Boot to be enabled, the computer is required to be in UEFI boot mode and the Enable Legacy Option ROMs option is required to be turned off.</p>
Secure Boot Mode	<p>Enables or disables the Secure Boot operation mode.</p> <p>By default, the Deployed Mode is selected.</p> <p> NOTE: Deployed Mode should be selected for normal operation of Secure Boot.</p>
Enable Microsoft UEFI CA	<p>When disabled, the UEFI CA is removed from the BIOS UEFI Secure Boot database.</p> <p> CAUTION: When disabled, the Microsoft UEFI CA can cause your system to not boot, computer graphics may not function, some devices may not function properly, and the computer could become unrecoverable.</p> <p>By default, the Enable Microsoft UEFI CA option is enabled.</p> <p>For additional security, Dell Technologies recommends keeping the Enable Microsoft UEFI CA option enabled to ensure the broadest compatibility with devices and operating systems.</p>

Table 31. BIOS Setup options—Boot Configuration menu (continued)

Boot Configuration	
Expert Key Management	
Enable Custom Mode	Enables or disables the ability to modify the keys in the PK, KEK, db, and dbx security key databases to be modified. By default, the Enable Custom Mode option is disabled.
Custom Mode Key Management	Selects the custom values for expert key management. By default, the PK option is selected.

Table 32. BIOS Setup options—Integrated Devices menu

Integrated Devices	
Date/Time	
Date	Sets the computer date in MM/DD/YYYY format. Changes to the date format take effect immediately.
Time	Sets the computer time in HH/MM/SS 24-hour format. You can switch between a 12-hour and 24-hour clock. Changes to the time format take effect immediately.
Camera	
Enable Camera	Enables the camera. By default, the Enable Camera option is enabled. i NOTE: Depending on the configuration ordered, the camera setup option may not be available.
Audio	
Enable Audio	Enables all integrated audio controller. By default, all the options are enabled.
Enable Microphone	Enables the microphone. By default, the Enable Microphone option is enabled. i NOTE: Depending on the configuration ordered, the microphone setup option may not be available.
Enable Internal Speaker	Enables the internal speaker. By default, the Enable Internal Speaker option is enabled.
USB/Thunderbolt Configuration	
Enable USB Boot Support	Enables booting from USB mass storage devices that are connected to external USB ports. By default, the Enable USB Boot Support option is enabled.
Enable External USB Ports	Enables the external USB ports. By default, the Enable External USB Ports option is enabled.
Enable Thunderbolt Technology Support	
Enable Thunderbolt Technology Support	Enables the associated ports and adapters for Thunderbolt Technology support. By default, the Enable Thunderbolt Technology Support option is enabled.
Enable Thunderbolt Boot Support	
Enable Thunderbolt Boot Support	Enables the Thunderbolt adapter-peripheral device and USB devices that are connected to the Thunderbolt adapter to be used during BIOS Preboot.

Table 32. BIOS Setup options—Integrated Devices menu (continued)

Integrated Devices	
	By default, the Enable Thunderbolt Boot Support option is disabled.
Miscellaneous Devices	
Enable Fingerprint Reader Device	Enables the Fingerprint Reader Device option. By default, the Enable Fingerprint Reader Device option is enabled.

Table 33. BIOS Setup options—Connection menu

Connection	
Wireless Device Enable	
WLAN	Enables or disables the internal WLAN device. By default, the WLAN option enabled.
Bluetooth®	Enables or disables the internal Bluetooth device. By default, the Bluetooth option enabled.
Enable UEFI Network Stack	Enables or disables the UEFI Network Stack and controls the onboard LAN Controller. By default, the Enable UEFI Network Stack option is enabled.
HTTP(s) Boot Feature	
HTTP(s) Boot	Enable or disable the HTTPs Boot feature. By default, the HTTP(s) Boot option is enabled.
HTTP(s) Boot Modes	With Auto Mode, the HTTPs Boot extracts Boot URL from the DHCP. With Manual Mode, the HTTPs Boot reads Boot URL from the user-provided data. By default, the Auto Mode option is enabled.

Table 34. BIOS Setup options—Storage menu

Storage	
Storage Interface	Displays the information of various onboard drives.
Port Enablement	Enables or disables the M.2 PCIe SSD option. By default, the M.2 PCIe SSD option is enabled.
Drive Information	Displays the information of onboard drives.

Table 35. BIOS Setup options—Display menu

Display	
Display Brightness	
Brightness on battery power	Enables to set the screen brightness when the computer is running on battery power. By default, the screen brightness is set to 50 when the computer is running on battery power.
Brightness on AC power	Enables to set the screen brightness when the computer is running on AC power. By default, the screen brightness is set to 100 when the computer is running on AC power.
Touchscreen	Enables or disables the touch screen option.

Table 35. BIOS Setup options—Display menu (continued)

Display	
By default, the Touchscreen option is enabled.	

Table 36. BIOS Setup options—Power menu

Power	
Thermal Management	<p>Enables or disables cooling of fan and manages processor heat to adjust the computer performance, noise, and temperature.</p> <p>By default, the Optimized option is selected. Standard setting for balanced performance, noise, and temperature.</p>
Lid Switch	
Enable Lid Switch	<p>Enables or disables the Lid Switch.</p> <p>By default, the Enable Lid Switch option is enabled.</p>
Power On Lid Open	<p>When enabled, it allows the computer to turn on from the off state whenever the lid is opened.</p> <p>By default, the Power On Lid Open option is enabled.</p>

Table 37. BIOS Setup options—Security menu

Security	
TPM 2.0 Security	
TPM 2.0 Security On	<p>Allows you to enable or disable TPM.</p> <p>By default, the TPM On option is enabled.</p> <p>For additional security, Dell Technologies recommends keeping TPM On enabled to allow these security technologies to fully function.</p>
Attestation Enable	<p>The Attestation Enable option controls the endorsement hierarchy of TPM. Disabling the Attestation Enable option prevents TPM from being used to digitally sign certificates.</p> <p>By default, the Attestation Enable option is enabled.</p> <p>For additional security, Dell Technologies recommends keeping the Attestation Enable option enabled.</p> <p>NOTE: When disabled, this feature may cause compatibility issues or loss of functionality in some operating systems.</p>
Key Storage Enable	<p>The Key Storage Enable option controls the storage hierarchy of TPM, which is used to store digital keys. Disabling the Key Storage Enable option restricts the ability of TPM to store owner's data.</p> <p>By default, the Key Storage Enable option is enabled.</p> <p>For additional security, Dell Technologies recommends keeping the Key Storage Enable option enabled.</p> <p>NOTE: When disabled, this feature may cause compatibility issues or loss of functionality in some operating systems.</p>
PPI Bypass for Clear Commands	<p>The PPI Bypass for Clear Commands option allows the operating system to manage certain aspects of PTT. When enabled, you are not prompted to confirm changes to the PTT configuration.</p> <p>By default, the PPI Bypass for Clear Commands option is disabled.</p> <p>For additional security, Dell Technologies recommends keeping the PPI Bypass for Clear Commands option disabled.</p>

Table 37. BIOS Setup options—Security menu (continued)

Security	
Chassis intrusion	
Chassis Intrusion	<p>The chassis intrusion detection enables a physical switch that triggers an event when the computer cover is opened.</p> <p>When set to Enabled, a notification is displayed on the next boot and the event is logged in the BIOS Events log.</p> <p>When set to On-Silent, the event is logged in the BIOS Events log, but no notification is displayed. By default, the On-Silent option is enabled.</p> <p>When set to Disabled, no notification is displayed and no event is logged in the BIOS Events log.</p> <p>For additional security, Dell Technologies recommends keeping the Chassis Intrusion Detection option enabled.</p>
Clear Intrusion Warning	<p>Enable or disable Clear Intrusion Warning.</p> <p>By default, the option is disabled.</p>
Data Wipe on Next Boot	
Start Data Wipe	<p>Data Wipe is a secure wipe operation that deletes information from a storage device.</p> <p> CAUTION: The secure Data Wipe operation deletes information in a way that it cannot be reconstructed.</p> <p>Commands such as delete and format in the operating system may remove files from showing up in the file system. However, they can be reconstructed through forensic means as they are still represented on the physical media. Data Wipe prevents this reconstruction and is not recoverable.</p> <p>When enabled, the data wipe option will prompt to wipe any storage devices that are connected to the computer on the next boot.</p> <p>By default, the Start Data Wipe option is disabled.</p>
UEFI Boot Path Security	<p>Enables or disables the computer to prompt the user to enter the Administrator password (if set) when booting to a UEFI boot path device from the F12 boot menu.</p> <p>By default, the Always Except Internal HDD option is enabled.</p>
Pluton Security Processor	
Pluton Security Processor	<p>Pluton Security Processor is used by the operating system to provide security services such as Key Storage Provider functionality. When enabled, the Pluton Security Processor services are available to the operating system. Disabling the Pluton Security Processor might limit some operating system security services and impact functionality.</p> <p>By default, the Pluton Security Processor option is enabled.</p>

Table 38. BIOS Setup options—Passwords menu

Passwords	
Admin Password	<p>The Administrator Password prevents unauthorized access to the BIOS Setup options. Once the administrator password is set, the BIOS setup options can only be modified after providing the correct password.</p> <p>The following rules and dependencies apply to the Administrator Password -</p> <ul style="list-style-type: none"> • The administrator password cannot be set if computer and/or internal hard drive passwords are previously set. • The administrator password can be used in place of the computer and/or internal hard drive passwords.

Table 38. BIOS Setup options—Passwords menu (continued)

Passwords	
	<ul style="list-style-type: none"> • When set, the administrator password must be provided during a firmware update. • Clearing the administrator password also clears the computer password (if set). <p>Dell Technologies recommends using an administrator password to prevent unauthorized changes to BIOS setup options.</p>
System Password	<p>The System Password prevents the computer from booting to an operating system without entering the correct password.</p> <p>The following rules and dependencies apply when the System Password is used -</p> <ul style="list-style-type: none"> • The computer shuts down when idle for approximately 10 minutes at the computer password prompt. • The computer shuts down after three incorrect attempts to enter the computer password. • The computer shuts down when the Esc key is pressed at the System Password prompt. • The computer password is not prompted when the computer resumes from standby mode. <p>Dell Technologies recommends using the computer password in situations where it is likely that a computer may be lost or stolen.</p>
M.2 PCIe SSD-0	Set, change, or delete the M.2 PCIe SSD-0 password.
Password Configuration	<p>The Password configuration page includes several options for changing the requirements of BIOS passwords. You can modify the minimum and maximum length of the passwords and require passwords to contain certain character classes (upper case, lower case, digit, special character).</p> <p>Dell Technologies recommends setting the minimum password length to at least eight characters.</p>
Upper Case Letter	<p>Forces the password to have at least one uppercase letter.</p> <p>Default: OFF</p>
Lower Case Letter	<p>Forces the password to have at least one lowercase letter.</p> <p>Default: OFF</p>
Digit	<p>Forces the password to have at least one digit number.</p> <p>Default: OFF</p>
Special Character	<p>Forces the password to have at least one special character.</p> <p>Default: OFF</p>
Minimum Characters	<p>Sets the minimum characters allowed for the password.</p> <p>Default: 04</p>
Password Changes	
Allow Non-Admin Password Changes	<p>The Allow Non-Admin Password Changes option in BIOS setup allows an end user to set or change the computer or hard drive passwords without entering the administrator password. This gives an administrator control over the BIOS settings but enables an end user to provide their own password.</p> <p>By default, the Allow Non-Admin Password Changes option is disabled.</p> <p>For additional security, Dell Technologies recommends keeping the Allow Non-Admin Password Changes option disabled.</p>
Admin Setup Lockout	

Table 38. BIOS Setup options—Passwords menu (continued)

Passwords	
Enable Admin Setup Lockout	<p>The Admin Setup Lockout option prevents an end user from even viewing the BIOS setup configuration without first entering the administrator password (if set).</p> <p>By default, the Admin Setup Lockout option is disabled.</p> <p>For additional security, Dell Technologies recommends keeping the Enable Admin Setup Lockout option disabled.</p>
Master Password Lockout	
Enable Master Password Lockout	<p>The Master Password Lockout setting allows you to disable the Recovery Password feature. If the computer, administrator, or hard drive password is forgotten, the computer becomes unusable.</p> <p>i NOTE: When the owner password is set, the Master Password Lockout option is not available.</p> <p>i NOTE: When an internal hard drive password is set, it must first be cleared before Master Password Lockout can be changed.</p> <p>By default, the Enable Master Password Lockout option is disabled.</p> <p>Dell does not recommend enabling the Master Password Lockout unless you have implemented your own password recovery computer.</p>
Allow Non-Admin PSID Revert	
Enable Allow Non-Admin PSID Revert	<p>Controls access to the Physical Security ID (PSID) revert of NVMe hard-drives from the Dell Security Manager prompt.</p> <p>By default, the option is disabled.</p>

Table 39. BIOS Setup options—Update, Recovery menu

Update, Recovery	
BIOS Downgrade	
Allow BIOS Downgrade	<p>Controls flashing of the computer firmware to previous revisions.</p> <p>By default, the Allow BIOS Downgrade option is enabled.</p>

Table 40. BIOS Setup options—System Management menu

System Management	
Service Tag	Displays the Service Tag of the computer.
Asset Tag	<p>Creates a computer Asset Tag that can be used by an IT administrator to uniquely identify a particular computer.</p> <p>i NOTE: Once set in BIOS, the Asset Tag cannot be changed.</p>
AC Behavior	
Wake on AC	<p>Enables or disables the computer to turn on and go to boot when AC power is supplied to the computer.</p> <p>By default, the Wake on AC option is disabled.</p>
Wake on LAN	<p>Enables or disables the computer to turn on by a special LAN signal.</p> <p>By default, the Wake on LAN option is disabled.</p>
Auto On Time	<p>Enable to set the computer to turn on automatically every day or on a preselected date and time. This option can be configured only if the Auto On Time is set to Everyday, Weekdays, or Selected Days.</p> <p>By default, the Auto On Time option is disabled.</p>

Table 41. BIOS Setup options—Keyboard menu

Keyboard	
Fn Lock Options	Enables or disables the Fn Lock option. By default, the Fn Lock option is enabled.
Lock Mode	By default, the Lock Mode Secondary option is enabled. With this option, the F1-F12 keys scan the code for their secondary functions.
Keyboard Illumination	Configures the operating mode of the keyboard illumination feature. By default, the Bright option is selected. Enables the keyboard illumination feature at 100% brightness level.
Keyboard Backlight Timeout on AC	Sets the timeout value for the keyboard backlight when an AC adapter is connected to the computer. By default, the 1 minute option is selected.
Keyboard Backlight Timeout on Battery	Sets the timeout value for the keyboard backlight when the computer is running only on the battery power. The keyboard backlight timeout value is only effective when the backlight is enabled. By default, the 1 minute option is selected.

Table 42. BIOS Setup options—Pre-boot Behavior menu

Pre-boot Behavior	
Sign of Life	
Early Keyboard Backlight	Keyboard Backlight Sign of Life. By default, the Early Keyboard Backlight option is enabled.

Table 43. BIOS Setup options—System Logs menu

System Logs	
BIOS Event Log	
Clear BIOS Event Log	Allows you to select option to keep or clear BIOS events logs. By default, the Keep Log option is selected.

Updating the BIOS

Updating the BIOS in Windows

Steps

1. Go to [Dell Support Site](#).
2. Click **Product support**. In the **Search support** box, enter the Service Tag of your computer, and then click **Search**.
 **NOTE:** If you do not have the Service Tag, use the SupportAssist to automatically identify your computer. You can also use the product ID or manually browse for your computer model.
3. Click **Drivers & Downloads**. Expand **Find drivers**.
4. Select the operating system installed on your computer.
5. In the **Category** drop-down list, select **BIOS**.
6. Select the latest version of BIOS, and click **Download** to download the BIOS file for your computer.
7. After the download is complete, browse the folder where you saved the BIOS update file.
8. Double-click the BIOS update file icon and follow the on-screen instructions.

For more information about how to update the system BIOS, search in the Knowledge Base Resource at [Dell Support Site](#).

Updating the BIOS using the USB drive in Windows

Steps

1. Follow the procedure from step 1 to step 6 in [Updating the BIOS in Windows](#) to download the latest BIOS Setup program file.
2. Create a bootable USB drive. For more information, search the Knowledge Base Resource at [Dell Support Site](#).
3. Copy the BIOS Setup program file to the bootable USB drive.
4. Connect the bootable USB drive to the computer that needs the BIOS update.
5. Restart the computer and press **F12**.
6. Select the USB drive from the **One Time Boot Menu**.
7. Type the BIOS Setup program filename and press **Enter**.
The **BIOS Update Utility** appears.
8. Follow the on-screen instructions to complete the BIOS update.

Updating the BIOS from the One Time Boot menu

Update your computer BIOS using the BIOS XXXX.exe file that is copied to a FAT32 USB drive and booting from the **One Time Boot** menu.

About this task

BIOS Update

You can run the BIOS update file from Windows using a bootable USB drive or you can also update the BIOS from the **One Time Boot** menu on the computer.

You can confirm by booting your computer to the **One Time Boot** Menu to see if BIOS FLASH UPDATE is listed as a boot option. If the option is listed, then the BIOS can be updated using this method..

Updating from the One Time Boot menu

To update your BIOS from the **One Time Boot** menu, you need the following:

- USB drive formatted to the FAT32 file system (the drive does not have to be bootable)
- BIOS executable file that you downloaded from the Dell Support website and copied to the root of the USB drive
- AC power adapter must be connected to the computer
- Functional computer battery to flash the BIOS

Perform the following steps to perform the BIOS flash update process from the menu:

 **CAUTION: Do not turn off the computer during the BIOS flash update process. The computer may not boot if you turn off your computer.**

Steps

1. Turn off your computer, insert the USB drive where you copied the BIOS flash update file into a USB port of the computer.
2. Turn on the computer and press to access the **One Time Boot** Menu. Select BIOS flash Update using the mouse or arrow keys then press Enter.
The flash BIOS menu is displayed.
3. Click **Flash from file**.
4. Select the external USB device.
5. Select the file and double-click the flash target file, and then click **Submit**.
6. Click **Update BIOS**. The computer restarts to flash the BIOS.
7. The computer will restart after the BIOS flash update is completed.

System and setup password

Table 44. System and setup password

Password type	Description
System password	Password that you must enter to log in to your system.
Setup password	Password that you must enter to access and make changes to the BIOS settings of your computer.

You can create a system password and a setup password to secure your computer.

 **CAUTION:** The password features provide a basic level of security for the data on your computer.

 **CAUTION:** Anyone can access the data that is stored on your computer, when left unattended.

 **NOTE:** System and setup password feature is disabled.

Assigning a System Setup password

Prerequisites

You can assign a new System or Admin Password only when the status is in **Not Set**.

About this task

To enter BIOS System Setup, press F2 immediately after a power-on or reboot.

Steps

1. In the **System BIOS** or **System Setup** screen, select **Security** and press Enter.
The **Security** screen is displayed.
2. Select **System/Admin Password** and create a password in the **Enter the new password** field.
Use the following guidelines to assign the system password:
 - A password can have up to 32 characters.
 - At least one special character: "(! " # \$ % & ' * + , - . / : ; < = > ? @ [\] ^ _ ` { | })")"
 - Numbers 0 to 9.
 - Upper case letters from A to Z.
 - Lower case letters from a to z.
3. **Confirm new password** type the system password that you entered earlier in the field and click **OK**.
4. Press Esc and save the changes as prompted by the message.
5. Press Y to save the changes.
The computer restarts.

Deleting or changing an existing system password or setup password

Prerequisites

Ensure that the **Password Status** is Unlocked (in the System Setup) before attempting to delete or change the existing system password and/or setup password. You cannot delete or change an existing system password or setup password if the **Password Status** is Locked.

About this task

To enter the System Setup, press F2 immediately after a power-on or reboot.

Steps

1. In the **System BIOS** or **System Setup** screen, select **System Security** and press Enter. The **System Security** screen is displayed.
2. In the **System Security** screen, verify that the **Password Status** is Unlocked.
3. Select **System Password**. Update or delete the existing system password, and press Enter or Tab.
4. Select **Setup Password**. Update or delete the existing setup password, and press Enter or Tab.
 **NOTE:** If you change the system password and/or setup password, reenter the new password when prompted. If you delete the system password and/or setup password, confirm the deletion when prompted.
5. Press Esc. A message prompts you to save the changes.
6. Press Y to save the changes and exit from **System Setup**. The computer restarts.

Clearing CMOS settings

About this task

 **CAUTION:** Clearing CMOS settings resets the BIOS settings on your computer.

Steps

1. Remove the [base cover](#).
2. Disconnect the battery cable from the system board.
3. Remove the [coin-cell battery](#).
4. Wait for one minute.
5. Install the [coin-cell battery](#).
6. Connect the battery cable to the system board.
7. Install the [base cover](#).

Clearing BIOS (System Setup) and System passwords

About this task

To clear the computer or BIOS passwords, contact Dell technical support as described at [Contact Support](#). For more information, go to [Dell Support Site](#).

 **NOTE:** For information about how to reset Windows or application passwords, see the documentation accompanying Windows or your application.

Clearing chassis intrusion alert

The computer features a chassis intrusion switch that detects when the base cover had been removed from the computer.

Alerts to notify you of any intrusions can be enabled through the **Chassis Intrusion** field in the **Security** submenu of the BIOS setup menu.

When enabled, the **Block Boot Until Cleared** field allows you to choose whether to prevent normal boot-up of the computer until the intrusion alert is cleared.

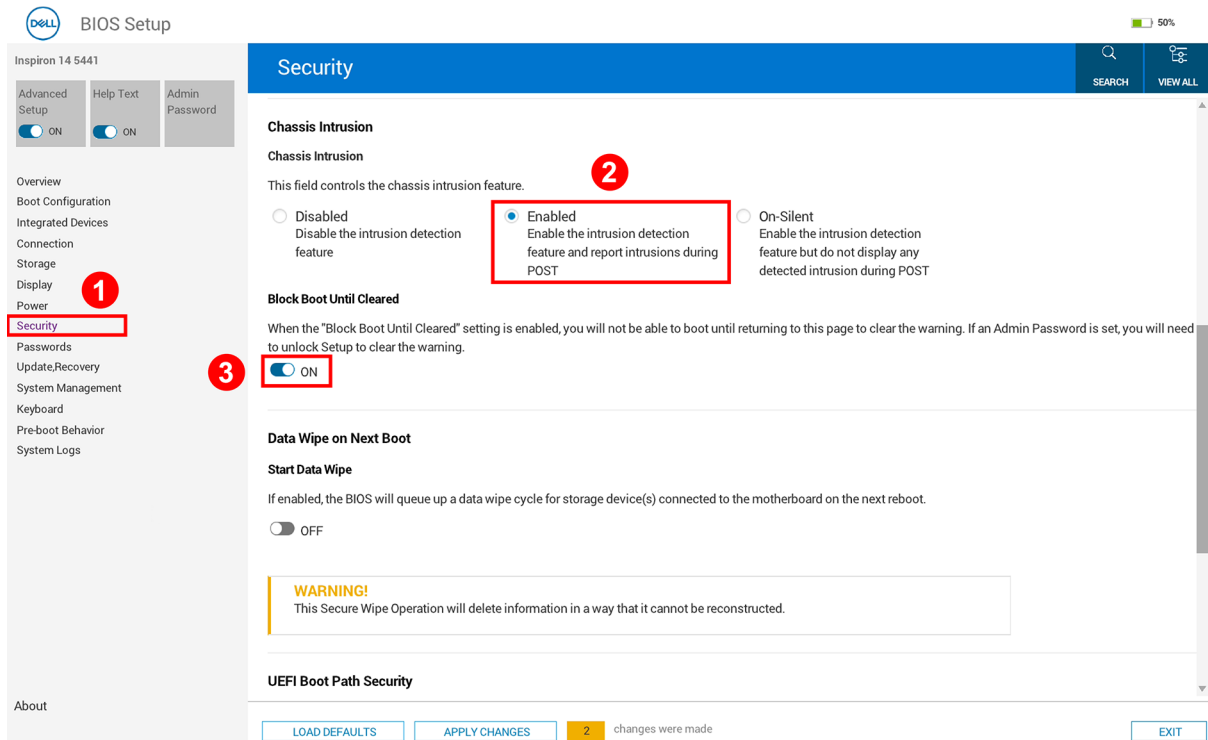

Figure 65. Enable block boot until cleared

If **Block Boot Until Cleared** is set to **ON**, select **BIOS-Setup** to clear the alert so the computer boots up normally.

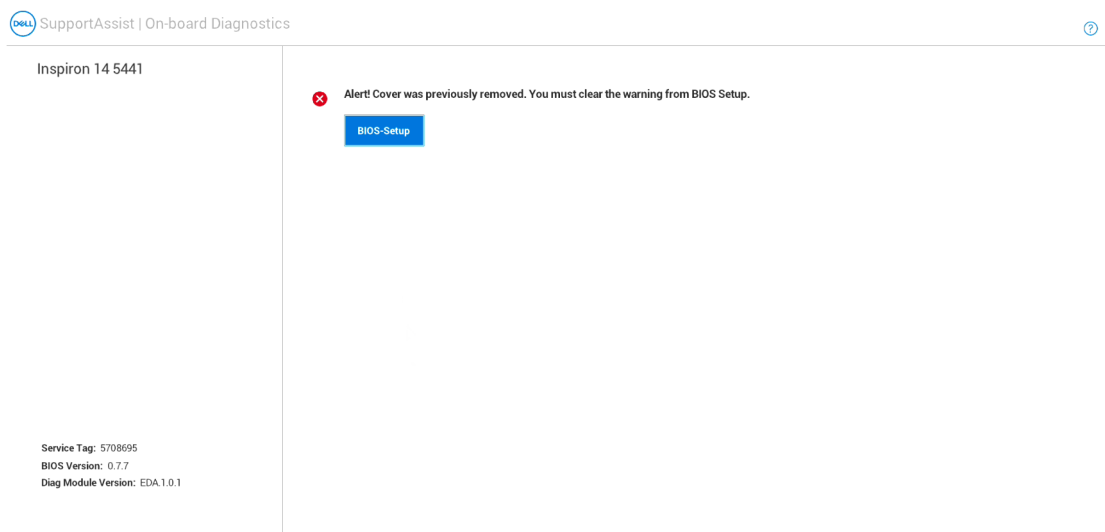

Figure 66. Clear chassis intrusion alert

If **Block Boot Until Cleared** is set to **OFF**, select **Continue** or **BIOS-Setup** to clear the alert so the computer boots up normally.

Inspiron 14 5441

Alert! Cover was previously removed.
 Note: This warning can be disabled in BIOS setup.

Continue BIOS-Setup Diagnostics

Service Tag: 8343132
 BIOS Version: 0.5.0
 Diag Module Version: EDA.1.0.0

Figure 67. Clear chassis intrusion alert

NOTE: If **Continue** is selected, the user continues to see the alert each time the computer is turned on until the alert is cleared.

To clear the alert, select **ON** in the **Clear Intrusion Warning** field in the **Security** submenu of the BIOS setup menu.

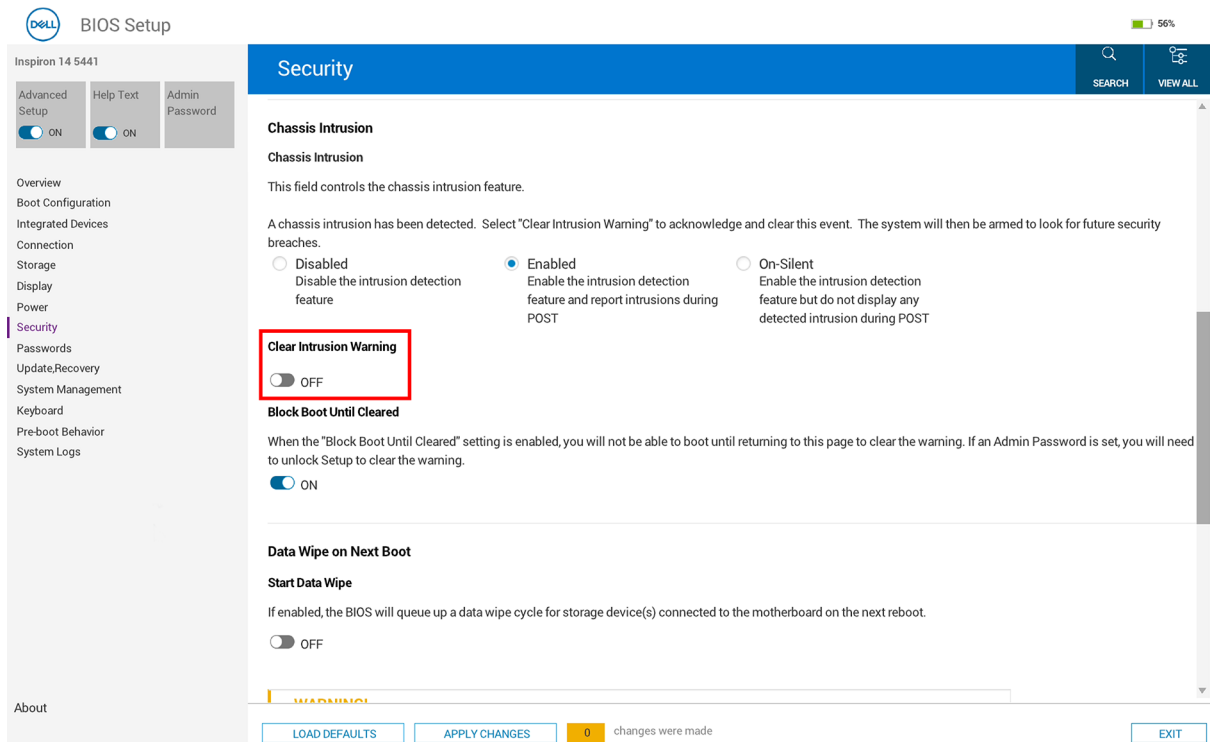

Figure 68. Clear intrusion warning

Troubleshooting

Handling swollen rechargeable Li-ion batteries

Like most laptops, Dell laptops use Lithium-ion batteries. One type of Lithium-ion battery is the rechargeable Li-ion battery. Rechargeable Li-ion batteries have increased in popularity in recent years and have become a standard in the electronics industry due to customer preferences for a slim form factor (especially with newer ultra-thin laptops) and long battery life. Inherent to rechargeable Li-ion battery technology is the potential for swelling of the battery cells.

A swollen battery may impact the performance of the laptop. To prevent possible further damage to the device enclosure or internal components leading to malfunction, discontinue the use of the laptop and discharge it by disconnecting the AC adapter and letting the battery drain.

Swollen batteries should not be used and must be replaced and disposed of properly. We recommend contacting Dell Support for options to replace a swollen battery under the terms of the applicable warranty or service contract, including options for replacement by a Dell authorized service technician.

The guidelines for handling and replacing rechargeable Li-ion batteries are as follows:

- Exercise caution when handling rechargeable Li-ion batteries.
- Discharge the battery before removing it from the computer. To discharge the battery, unplug the AC adapter from the computer and operate the computer only on battery power. The battery is fully discharged when the computer no longer turns on when the power button is pressed.
- Do not crush, drop, mutilate, or penetrate the battery with foreign objects.
- Do not expose the battery to high temperatures, or disassemble battery packs and cells.
- Do not apply pressure to the surface of the battery.
- Do not bend the battery.
- Do not use tools of any type to pry on or against the battery.
- If a battery gets stuck in a device as a result of swelling, do not try to free it as puncturing, bending, or crushing a battery can be dangerous.
- Do not attempt to reassemble a damaged or swollen battery into a laptop.
- Swollen batteries that are covered under warranty should be returned to Dell in an approved shipping container (provided by Dell)—this is to comply with transportation regulations. Swollen batteries that are not covered under warranty should be disposed of at an approved recycling center. Contact Dell Support at [Dell Support Site](#) for assistance and further instructions.
- Using a non-Dell or incompatible battery may increase the risk of fire or explosion. Replace the battery only with a compatible battery purchased from Dell that is designed to work with your Dell computer. Do not use a battery from other computers with your computer. Always purchase genuine batteries from [Dell Site](#) or otherwise directly from Dell.

Rechargeable Li-ion batteries can swell for various reasons such as age, number of charge cycles, or exposure to high heat. For more information about how to improve the performance and lifespan of the laptop battery and to minimize the possibility of occurrence of the issue, search Dell laptop battery in the Knowledge Base Resource at [Dell Support Site](#).

Locating the Service Tag or Express Service Code of your Dell computer

Your Dell computer is uniquely identified with a Service Tag or Express Service Code. To view relevant support resources for your Dell computer, we recommend entering the Service Tag or Express Service Code at [Dell Support Site](#).

For more information about how to find the Service Tag for your computer, see [Instructions on how to find your Service Tag or Serial Number](#).

Dell SupportAssist Pre-boot System Performance Check diagnostics

About this task

SupportAssist diagnostics (also known as system diagnostics) performs a complete check of your hardware. The Dell SupportAssist Pre-boot System Performance Check diagnostics is embedded with the BIOS and launched by the BIOS internally. The embedded system diagnostics provides options for particular devices or device groups allowing you to:

- Run tests automatically or in an interactive mode.
- Repeat the tests.
- Display or save test results.
- Run thorough tests to introduce additional test options to provide extra information about one or more failed devices.
- View status messages that inform you the tests are completed successfully.
- View error messages that inform you of problems encountered during testing.

 **NOTE:** Some tests for specific devices require user interaction. Always ensure that you are present at the computer when the diagnostic tests are performed.

For more information, see the knowledge base article [000180971](#).

Running the SupportAssist Pre-Boot System Performance Check

Steps

1. Turn on your computer.
2. As the computer boots, press the F12 key as the Dell logo appears.
3. On the boot menu screen, select the **Diagnostics** option.
4. Click the arrow at the bottom left corner.
Diagnostics page is displayed.
5. Click the arrow in the lower-right corner to go to the page listing.
The items that are detected are listed.
6. To run a diagnostic test on a specific device, press Esc and click **Yes** to stop the diagnostic test.
7. Select the device from the left pane and click **Run Tests**.
8. If there are any issues, error codes are displayed.
Note the error code and validation number and contact Dell.

Built-in self-test (BIST)

LCD Built-in Self-Test (BIST)

Dell laptops have a built-in diagnostic tool that helps you determine if the screen abnormality you are experiencing is an inherent problem with the LCD (screen) of the Dell laptop or with the video card (GPU) and computer settings.

When you notice screen abnormalities like flickering, distortion, clarity issues, fuzzy or blurry image, horizontal or vertical lines, color fade and so on, it is always a good practice to isolate the LCD (screen) by running the Built-In Self-Test (BIST).

How to invoke the LCD BIST

1. Turn off your computer.
2. Disconnect any peripherals that are connected to the computer. Connect only the AC adapter (charger) to the computer.
3. Ensure that the LCD (screen) is clean (no dust particles on the surface of the screen).
4. Press and hold the **D** key and press the power button to enter LCD built-in self-test (BIST) mode. Continue to hold the **D** key until the computer boots up.
5. The screen displays solid colors and change colors on the entire screen to white, black, red, green, and blue twice.
6. Then it displays the colors white, black, and red.

7. Carefully inspect the screen for abnormalities (any lines, fuzzy color, or distortion on the screen).
8. At the end of the last solid color (red), the computer shuts down.

NOTE: Dell SupportAssist Preboot diagnostics upon launch initiates an LCD BIST first, expecting a user intervention to confirm functionality of the LCD.

LCD Power rail test (L-BIST)

L-BIST is an enhancement to the single LED error code diagnostics and is automatically initiated during POST. L-BIST will check the LCD power rail. If there is no power being supplied to the LCD (that is if the L-BIST circuit fails), the battery status LED flashes either an error code [2,8] , [1,3], or [1,4].

NOTE: If L-BIST fails, LCD-BIST cannot function as no power will be supplied to the LCD.

How to invoke the L-BIST Test

1. Press the power button to start the computer.
2. If the computer does not start up normally, look at the battery status LED:
 - If the battery status LED flashes an error code [1,3] or [1,4], the display cable may not be connected properly.
 - If the battery status LED flashes an error code [2,8], there is a failure on the LCD power rail of the system board, hence there is no power that is supplied to the LCD.
3. For cases, when a [1,3] or [1,4], error code is shown, check to see if the display cable is properly connected.
4. For cases when a [2,8] error code is shown, replace the system board.

System-diagnostic lights

This section lists the system-diagnostic lights of your Inspiron 14 5441. The battery-charge status light also shows the system-diagnostic light codes of your computer.

Table 45. System-diagnostic lights

Blinking pattern		Problem description
Amber	White	
1	3	Short in hinge cable tripped OCP1
1	4	Short in hinge cable tripped OCP2
2	2	System board failure (included BIOS corruption or ROM error)
2	8	LCD failure (EC detection of power rail failure)

Backup media and recovery options

It is recommended to create a recovery drive to troubleshoot and fix problems that may occur with Windows. Dell provides multiple options for recovering the Windows operating system on your Dell computer. For more information, see [Dell Windows Backup Media and Recovery Options](#).

Wi-Fi power cycle

About this task

If your computer is unable to access the Internet due to Wi-Fi connectivity issues, reset your Wi-Fi device by performing the following steps:

Steps

1. Turn off the computer.
2. Turn off the modem.
 **NOTE:** Some Internet service providers (ISPs) provide a modem and router combo device.
3. Turn off the wireless router.
4. Wait for 30 seconds.
5. Turn on the wireless router.
6. Turn on the modem.
7. Turn on the computer.

Drain flea power (perform hard reset)

About this task

Flea power is the residual static electricity that remains in the computer even after it has been powered off and the battery is removed.

For your safety, and to protect the sensitive electronic components in your computer, you must drain residual flea power before removing or replacing any components in your computer.

Draining flea power, also known as performing a "hard reset," is also a common troubleshooting step if your computer does not turn on or boot into the operating system.

Perform the following steps to drain the flea power:

Steps

1. Turn off the computer.
2. Disconnect the power adapter from the computer.
3. Remove the base cover.
4. Remove the battery.
 **CAUTION: The battery is a Field Replaceable Unit (FRU) and the removal and installation procedures are intended for authorized service technicians only.**
5. Press and hold the power button for 20 seconds to drain the flea power.
6. Install the battery.
7. Install the base cover.
8. Connect the power adapter to the computer.
9. Turn on the computer.

 **NOTE:** For more information about performing a hard reset, search in the Knowledge Base Resource at the [Dell Support Site](#).

Getting help and contacting Dell Technologies

Self-help resources

You can get information and help on Dell Technologies products and services using these self-help resources:

Table 46. Self-help resources

Self-help resources	Resource location
Information about Dell Technologies products and services	Dell Site
Contact Support	In Windows search, type <code>Contact Support</code> , and press Enter.
Online help for operating system	Windows Support Site
Access top solutions, diagnostics, drivers and downloads, and learn more about your computer through videos, manuals, and documents.	Your Dell Technologies computer is uniquely identified using a Service Tag or Express Service Code. To view relevant support resources for your Dell Technologies computer, enter the Service Tag or Express Service Code at Dell Support Site . For more information about how to find the Service Tag for your computer, see Instructions on how to find your Service Tag or Serial Number .
Dell Technologies knowledge base articles	<ol style="list-style-type: none"> 1. Go to Dell Support Site. 2. On the menu bar at the top of the Support page, select Support > Support Library. 3. In the Search field on the Support Library page, type the keyword, topic, or model number, and then click or tap the search icon to view the related articles.

Contacting Dell Technologies

To contact Dell Technologies for sales, technical support, or customer service issues, see [Contact Support at Dell Support Site](#).

 **NOTE:** Availability of the services may vary depending on the country or region, and product.

 **NOTE:** If you do not have an active Internet connection, you can find contact information about your purchase invoice, packing slip, bill, or Dell Technologies product catalog.