

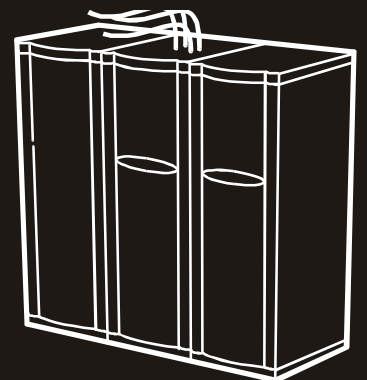

# Installation and Start-Up

## 60kW InfraStruXure™ System

Large Data Centers  
400/230V





# About this Manual

---

This manual is intended for APC Field Service Engineers or APC-trained installers of a 60kW InfraStruXure system. It covers basic installation and start-up.

For information about installing specific components in your InfraStruXure system, see the documentation included with each component. Before installing or operating any component, refer to the safety instructions in the component's manual.

The illustrations of products in this manual may vary slightly from the products in your InfraStruXure system.



**Note**

You can check for updates to this manual by clicking on the **User Manuals** link on the **Support** page of the APC Web site ([www.apc.com](http://www.apc.com)). In the list of InfraStruXure manuals, look for the latest letter revision (A, B, etc.) of the part number on this manual.



# Contents

---

<b>Safety</b> .....	<b>1</b>
<b>Overview</b> .....	<b>1</b>
Save these instructions .....	1
Safety symbols used in this manual .....	1
Cross-reference symbols used in this manual .....	1
<b>Warnings</b> .....	<b>2</b>
Unpacking/moving .....	2
Installation/Maintenance .....	2
Maintenance performed while the PDU is receiving input power .....	2
Total Power Off .....	2
Emergency Power Off (EPO) .....	3
EMI .....	3
<b>Site Planning</b> .....	<b>5</b>
Dimensions .....	5
Space Considerations .....	6
Weight Considerations .....	7
Heat Output .....	8
Electrical Requirements and Specifications .....	9
Emergency-Power Off (EPO) .....	10
Basic Installation Procedure .....	11
Tools Required .....	13
<b>Installation Procedures</b> .....	<b>15</b>
Level the PDU and NetShelter Enclosures .....	15

<b>Connect the Power Source to the PDU</b> . . . . .	<b>16</b>
Access the PDU Main Input switch . . . . .	16
Attach conduit to the PDU for the input conductors . . . . .	16
Install a circuit breaker . . . . .	18
Route the input conductors to the Main Input circuit breaker (or switch) . . . . .	18
Torque specs and tools required . . . . .	18
Connect input conductors . . . . .	19
 <b>Connect an Emergency Power Off Switch</b> . . . . .	 <b>20</b>
Overview . . . . .	20
Connect an EPO switch to the user connection plate and test the switch . . . . .	21
Safety warnings . . . . .	23
 <b>Connect User Input Contacts and Relay Outputs to the User Connection Plate</b> . . . . .	 <b>24</b>
Overview . . . . .	24
How to connect contacts to the PDU Monitoring Unit . . . . .	25
 <b>Install Shielding Troughs, Shielding Partitions, and Cable Ladders</b> . . . . .	 <b>26</b>
Shielding Troughs and Shielding Partitions for overhead wiring across rows . . . . .	26
Cable Ladders for overhead wiring across rows . . . . .	27
 <b>Install InfraStruXure Rack-Mount Devices</b> . . . . .	 <b>28</b>
Install the Rack Automatic Transfer Switches (ATS) . . . . .	28
Install the Rack Power Distribution Units (PDU) . . . . .	28
Install the InfraStruXure Manager and Hub (or Switch) . . . . .	28
Install the Environmental Monitoring Unit or Environmental Management System . . . . .	28
 <b>Route and Attach Overhead Wiring</b> . . . . .	 <b>29</b>
 <b>Wiring Under the Floor</b> . . . . .	 <b>32</b>
 <b>Route Data Cables to the InfraStruXure Manager Hub (or Switch)</b> . . . . .	 <b>34</b>
 <b>Start-Up Procedure</b> . . . . .	 <b>35</b>
Safety warnings . . . . .	35
Ensure that all power is off . . . . .	35
Apply power to the system . . . . .	36
 <b>Configure the InfraStruXure Manager</b> . . . . .	 <b>38</b>

**Appendix A: System Operation.....39**  
    How to Apply Power to the System . . . . . 39  
    How to Ensure Total Power Off . . . . . 40

**Appendix B: Changes in this Manual .....41**





# Safety

## Overview

---

### Save these instructions

This manual contains important instructions that must be followed during installation, operation, and maintenance of the InfraStruXure System.

### Safety symbols used in this manual



Indicates an electrical hazard, which, if not avoided, could result in injury or death.



Indicates a hazard, which, if not avoided, could result in personal injury or damage to product or other property.



Indicates a potential hazard which could result in damage to product or other property.



Indicates important information.



Indicates a heavy load that should not be lifted without assistance.



Indicates a standby state. When in standby, the unit is not operating, but it may still contain hazardous voltage. It is not safe to service until the equipment is disconnected from all sources of electrical power.

### Cross-reference symbols used in this manual



Indicates that more information is available on the same subject in a different manual.



Indicates that more information is available on the same subject in a different section of this manual.

# Warnings

---

## Unpacking/moving

DO NOT tilt the PDU greater than 45° from its vertical axis. Never lay the PDU on its side.

## Installation/Maintenance

Only a certified electrician can perform these tasks:

- Connect the PDU to its power source
- Connect a switch to the EPO interface on the PDU

Only a certified electrician or an APC Field Service Engineer can perform maintenance of the PDU.

When you connect the PDU to its power source, you must install a 125A circuit breaker to protect the PDU against short-circuit current. The circuit breaker must have a CE mark and a certification mark by a certified body such as VDE, SELV, BSI, Semko, Nemco, or Demko.

## Maintenance performed while the PDU is receiving input power

APC does not recommend that you perform maintenance of the PDU while it is receiving input power. However, due to the critical nature of data center loads, this may occur. If you must perform maintenance while the PDU is receiving input power, observe the following precautions to reduce the risk of electric shock:

1. Never work alone.
2. Perform the maintenance only if you are a certified electrician who is trained in the hazards of live electrical installation.
3. Know the procedure for disconnecting electricity to the PDU and the data center in case of an emergency.
4. Wear appropriate personal protective equipment.
5. Use double-insulated tools.
6. Always follow local and site regulations when working on the PDU.

## Total Power Off

1. Open (turn OFF) the PDU **Main Input**.
2. Set the upstream power source circuit breaker feeding the PDU to OFF.

## **Emergency Power Off (EPO)**

This InfraStruXure PDU and Symmetra PX UPS are provided with an Emergency Power Off switch connection. When this EPO switch is energized, electrical power to the units are de-energized and the system will not transfer to on-battery operation.

EPO can be achieved with either a contact closure or application of an external 24 VAC or 24 VDC from a SELV or PELV source. It's important to note that hazardous voltage from the Mains voltage must be isolated from the contact closure or 24 VAC, 24 VDC. The EPO circuit contact closure, the 24 VAC or the 24 VDC are considered a SELV circuit as defined in EN 60950 *Safety of Information Technology Equipment* or PELV circuit as defined in IEC 60364-4-41 *Electrical Installations of Buildings, Protection for Safety—Protection Against Electric Shock*. SELV is an abbreviation for Safety Extra Low Voltage. PELV is an abbreviation for Protective Extra Low Voltage. SELV and PELV circuits are isolated from the Mains through a safety isolating transformer, and are designed so that under normal conditions the voltage is limited to 42.4 V<sub>peak</sub> or 60 VDC.

## **EMI**

WARNING —This is a Class A product. In a domestic environment, this product may cause radio interference in which case, the user may be required to take adequate measures. This equipment has been tested and found to comply with EN55022 (1998) and EN55024.



# Site Planning

## Dimensions

### InfraStruXure PDU

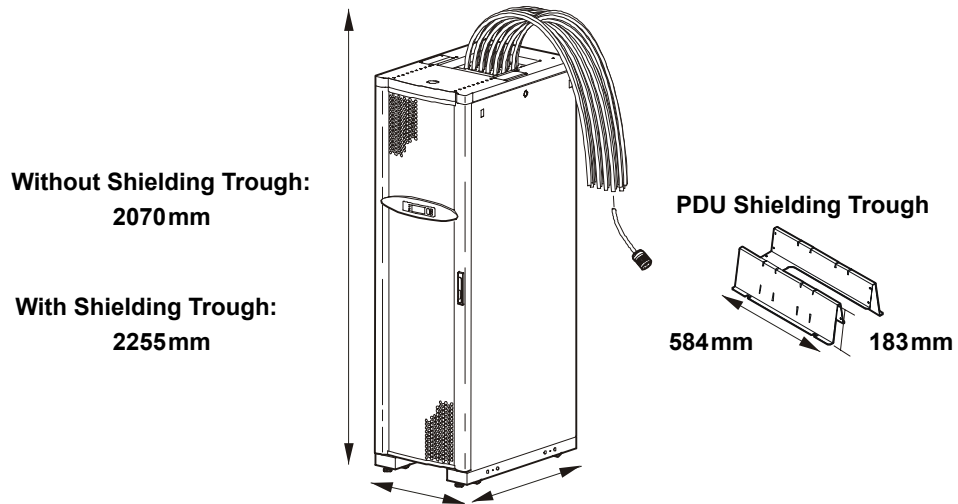

### NetShelter VX Enclosure

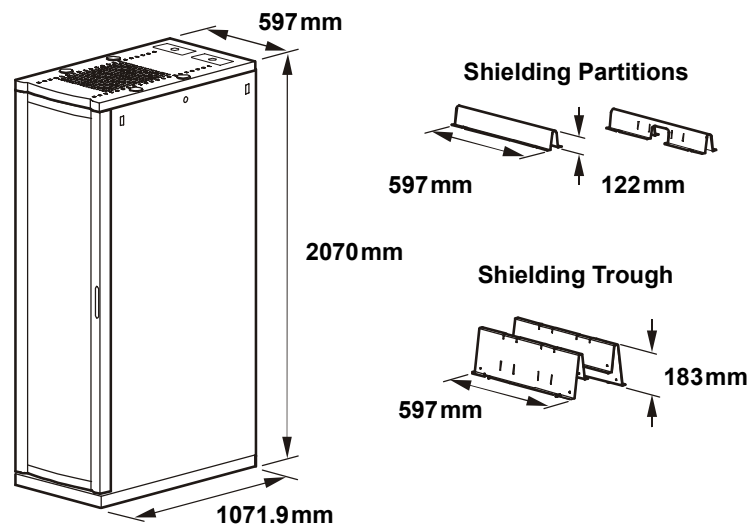

# Space Considerations

---

Study the figure below to determine your space requirements for installing the PDU. Consult your local codes and the NEC for additional requirements.

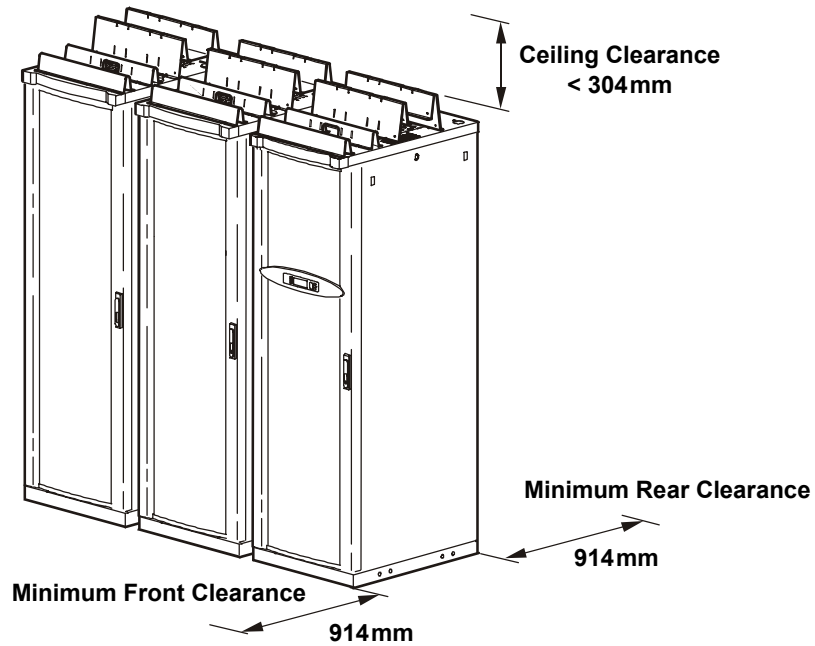

# Weight Considerations

---

Ensure that the floor and sub-floor can support the total weight of the configuration when concentrated on the leveling feet. If you are placing equipment on a raised floor, consult the flooring manufacturer for loading requirements before installing equipment.

<b>Component</b>	<b>Maximum Weight</b>
InfraStruXure PDU	
With a transformer	556kg
Without a transformer	352kg
NetShelter VX Base Enclosure (empty)	160kg

# Heat Output

---

Consider the heat dissipation ratings of equipment to determine cooling requirements. Additional cooling equipment may be required. Heat output of the PDU with a transformer is 7000 BTU/hr.



**Note**

The heat output is higher while batteries are charging. Under normal operating conditions, battery recharging periods are infrequent.



# Electrical Requirements and Specifications

---

## Procedures requiring a licensed electrician



Procedures requiring a licensed electrician include:

- Connection of input conductors
- Installation of a 125-amp input circuit breaker
- Wiring under the floor
- Any customer-specified, hard-wired power cable



To connect power, see “Connect the Power Source to the PDU” on page 14 of this manual.

## Electrical requirements

	Input
Service distribution breaker †‡	125A
Conductors to Main Input switch †	
Transformer:	L1, L2, L3, PE
No Transformer:	L1, L2, L3, N, PE
Recommended wire sizing ‡	
L1, L2, L3, N	35mm <sup>2</sup> , 90°C, XLPE or
PE	EPR insulation or 50mm <sup>2</sup> , 70°C, PVC insulation

† Provided by customer.

‡ The specifications are recommendations. Consult the NEC and local codes for requirements specific to your installation.

---

# Emergency-Power Off (EPO)

---

## Overview

To provide a mechanism for emergency-power off, attach a remote switch to the EPO interface on the PDU monitoring unit. The EPO interface (❶) is connected to the PDU Main Input switch (❷) and to the UPS internal EPO switch (❸).

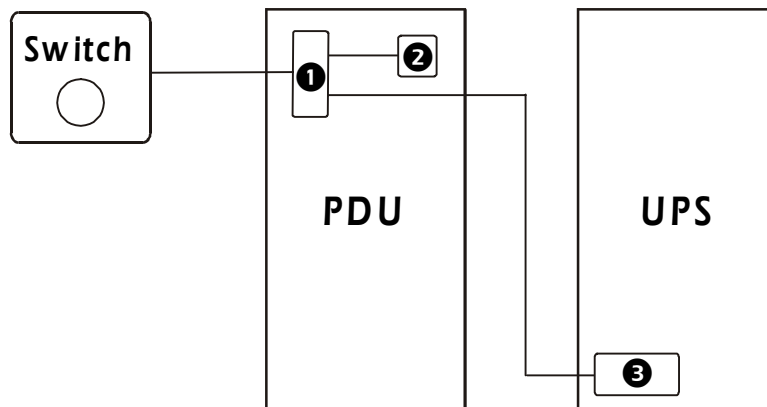

When the EPO is activated, the main input breaker to the PDU transformer is opened, the UPS DC Disconnect breaker is opened, and the UPS System Enable switch is turned off. In this sequence, there is no power from the PDU transformer and there is no power from the UPS inverters and batteries.



**Note**

APC offers an optional InfraStruXure EPO system (EPW9). Contact your APC sales representative, or visit the APC Web site ([www.apc.com](http://www.apc.com)) for more information.



See “Connect an Emergency Power Off Switch” on page 20 for instructions on how to connect an EPO switch to the PDU.

# Basic Installation Procedure

---

This section provides the basic steps that you need to perform when installing InfraStruXure power and rack components. Follow the references provided with each step for detailed instructions.



**Do not begin installing your InfraStruXure system without an APC Field Service Engineer present.**

Warning

1. Unpack the components according to the unpacking instructions included on the outside of the packaging or in the component's manual.



Note

Search all boxes and packaging to make sure that they are empty before discarding.

2. Determine the correct placement of your system components by studying your InfraStruXure Configure-To-Order (CTO) report. Move the PDU and NetShelter VX Enclosures to their final location.



Warning

**If installing InfraStruXure on a raised floor, make sure that the raised-floor structure has a lb/in<sup>2</sup> rating that will support the full weight of the InfraStruXure installation. See “Weight Considerations” on page 7.**

3. Level the PDU and NetShelter enclosures, using the 13/14-mm wrench included with each unit.



See page 13 for detailed instructions.

4. Join adjacent NetShelter enclosures.



See also

For instructions on joining adjacent NetShelter VX Enclosures, see the installation manual included with your enclosures.

5. Connect the power source to the PDU.  
**A licensed electrician must connect the power source.**



See page 14 for detailed instructions.

6. Connect an EPO switch to the PDU monitoring unit.



See page 18 for detailed instructions.

7. Install Shielding Troughs, Shielding Partitions, and Cable Ladders.



**See also**

For instructions, see the manuals included with your Shielding Troughs, Shielding Partitions, and Cable Ladders.

8. Install the Rack Automatic Transfer Switches (ATS), Rack Power Distribution Units, and other InfraStruXure rack-mount devices.



**See also**

For instructions, see the manuals included with your Rack ATS, Rack PDU, or other InfraStruXure rack-mount device.

9. Route and attach power cables to each Rack ATS and/or Rack PDU.



See page 25 for detailed instructions.

10. Route and attach communication cables to the InfraStruXure Manager hub (or switch).



See page 30 for detailed instructions.

11. Start the system.

**Only qualified, APC-trained personnel may perform a system start-up.**



See page 29 for detailed instructions.

12. Configure the InfraStruXure Manager.



**See also**

For instructions, see the manual included with your InfraStruXure Manager.

# Tools Required

---

The following tools are required to perform the procedures in this manual. Additional tools may be required for components not covered in this manual.

<b>Tool</b>	<b>Supplied?</b>
13-mm socket wrench	No
17-mm socket wrench	No
T-20 screwdriver	No
Standard screwdriver	No
Level	No
Open-ended wrench (14mm) for adjusting the leveling feet	Yes
Step ladder	No
Crimper	No
Volt-meter	No
Phase-rotation meter	No



# Installation Procedures

## Level the PDU and NetShelter Enclosures

---

Leveling feet are attached under the enclosure at each corner. The leveling feet can help provide a stable base if the selected floor space is uneven, but they are not intended to compensate for a badly sloped surface. To level the enclosure:

1. Fit the 14-millimeter end of the open-ended wrench (provided) to the hex head just above the round pad on the bottom of the leveling foot. Turn the wrench clockwise to extend the leveling foot until it makes firm contact with the floor.

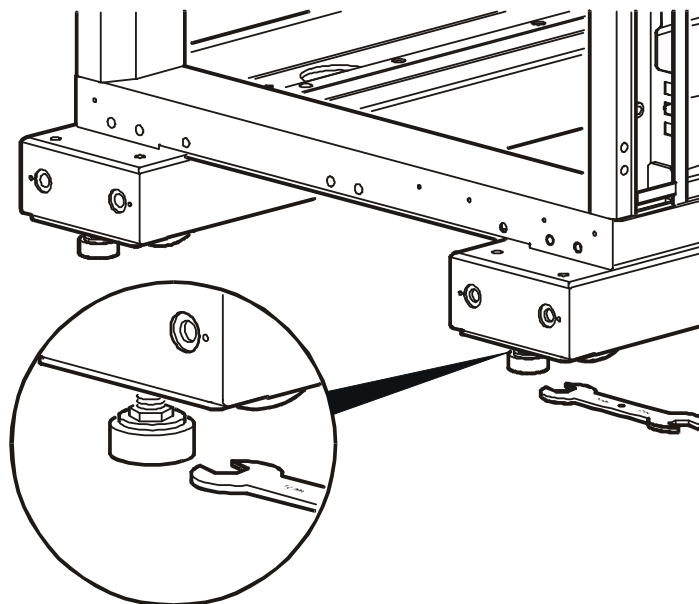

2. Repeat step 1 for each of the remaining leveling feet.
3. Use a level to determine which feet need further adjustment to level the enclosure. Adjust as necessary.

# Connect the Power Source to the PDU

---

## Access the PDU Main Input switch

Open the back doors of the PDU, unlock the top, smaller door, using the provided red key, and loosen the two screws holding the larger, hinged door in place.

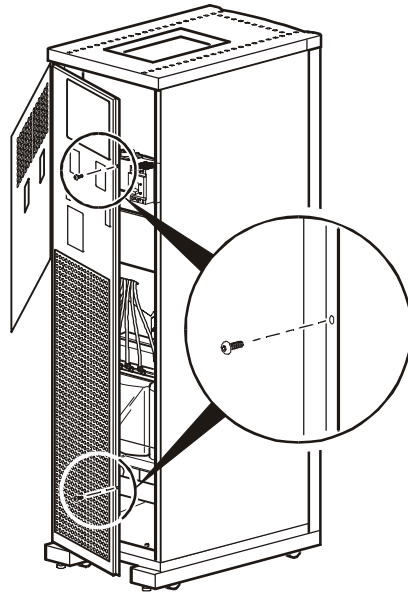

## Attach conduit to the PDU for the input conductors

1. Remove the rectangular gland plate by loosening the captive screws, using a Phillips or standard screwdriver:
  - In the bottom of the PDU for wiring under a raised floor

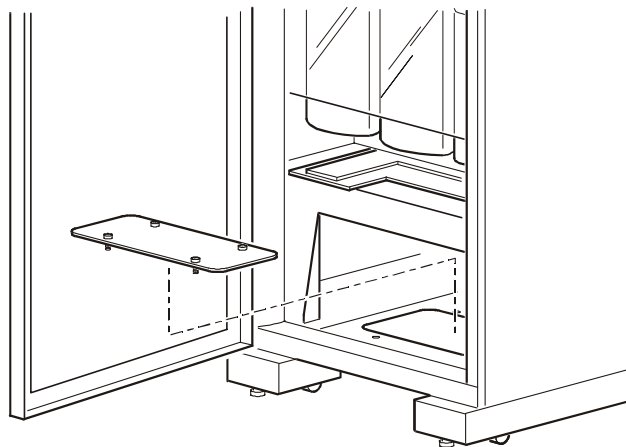



- In the top of the PDU for overhead wiring

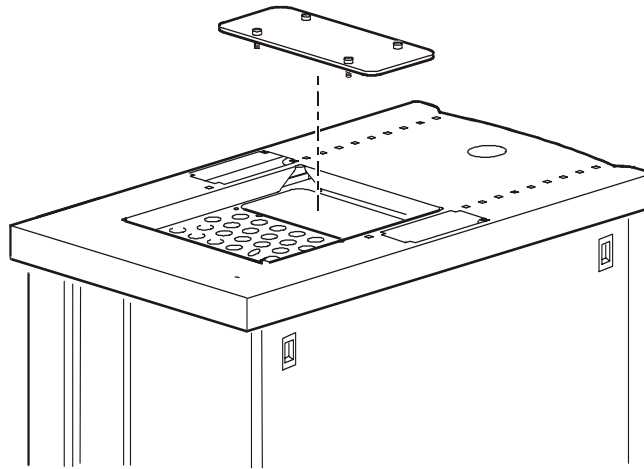

2. Cut an appropriately-sized hole in the gland plate for the cable.
3. Re-attach the gland plate.
4. Install a lock-nut and bushing to the cable.
5. Thread the cable through the hole.

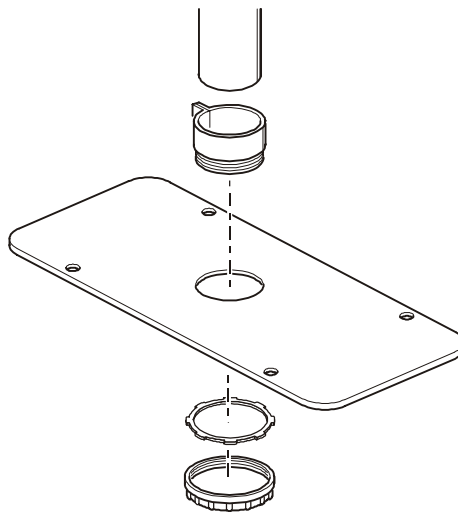

### Install a circuit breaker



**Make sure the cables used for power input are sufficiently protected by a 125A circuit breaker. Ratings are shown below.**

### Route the input conductors to the Main Input circuit breaker (or switch)

1. Route the input conductors to the Main Input circuit breaker (or switch) of the PDU, as follows:
  - For overhead wiring, run the input conductors directly to the Main Input circuit breaker (or switch).
  - For wiring under a raised floor, run the input conductors through the wireway (A) within the PDU to the Main Input circuit breaker (or switch).

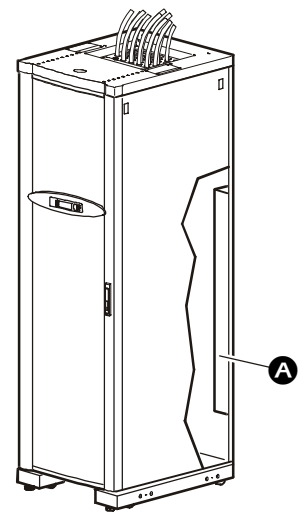

### Torque specs and tools required

Before connecting to the terminals, verify the torque specs below by checking the specifications on the Main input switch.

<b>Terminal</b>	<b>Torque</b>	<b>Tools</b>
L1, L2, L3, N	17n-m	6-mm Allen wrench
PE	14n-m	3/16-mm Allen wrench

## Connect input conductors



**A licensed electrician must connect input conductors to the PDU!**

At the Main Input circuit breaker (or switch), connect the input wiring according to the labels on the switch and the illustrations below. See the table, “Torque specs and tools required” on page 18 for specific information about connecting to each terminal.



**Connect the conductors to the terminals according to the labels on the terminals.  
Use copper conductors only.**

### 400 V input with a transformer:

L1, L2, L3, PE

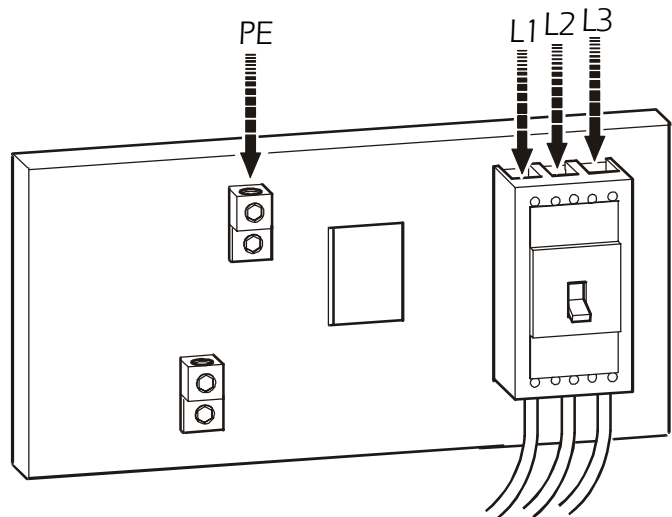

### 400 V input without a transformer:

L1, L2, L3, N, PE

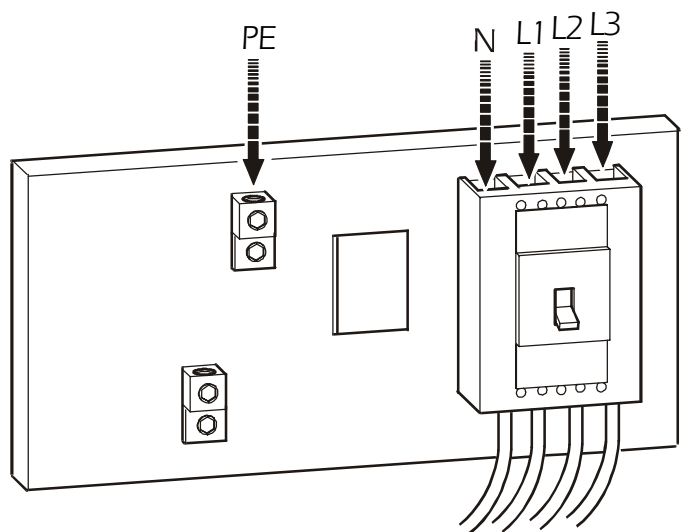



### Connect an EPO switch to the user connection plate and test the switch

1. Connect the switch to the EPO connection point terminals located on the bottom side of the PDU user connection plate. Read the label next to the terminal block to determine which terminals to connect to for the signal type you are using:

– **Contact Closure—Normally Open**

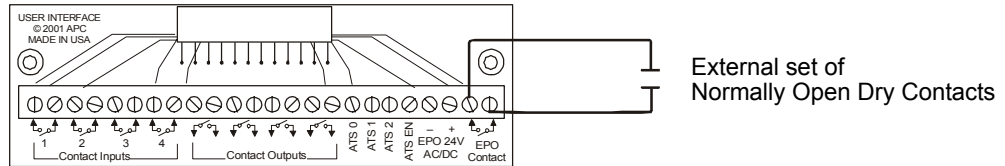

– **Contact Closure—Normally Closed**

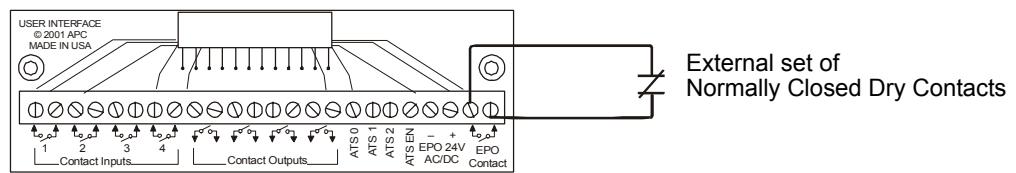

– **24 VAC/VDC—Normally Open**

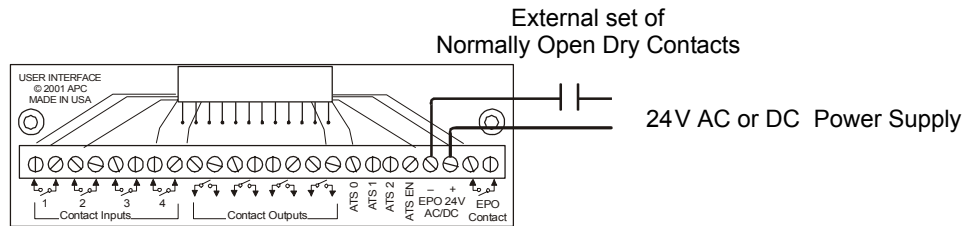

2. Verify that the EPO DIP switches on the PDU monitoring unit are configured properly for the signal type you are using. The labels above the switches and the figure below show the correct settings for both the Normally Open (NO) and Normally Closed (NC) position.

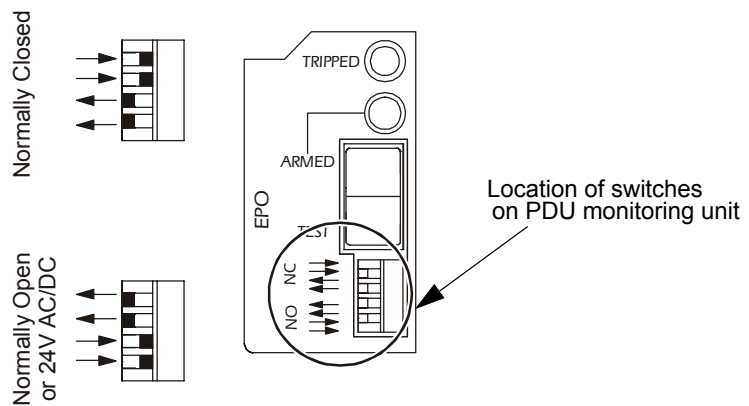

The default setting on the EPO interface on the PDU monitoring unit is for a **Normally Open (NO)** switch.

3. Test the EPO switch to ensure that it is wired and working correctly:
  - a. Place the Arm/Test rocker switch in the **Test** position. The EPO state LEDs will be off and the PDU display interface will show the following alarm (in addition to any other active alarms):

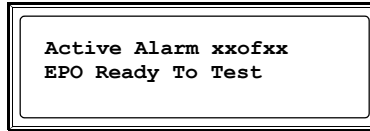

- b. Engage the EPO switch. (If your switch is momentary, engage it with one person watching the EPO state LEDs, and another at the EPO switch.)
  - c. Observe the EPO LEDs. If the switch is wired and working properly, when the switch is engaged, both of the EPO state LEDs are red.
  - d. If the test was successful, place the Arm/Test rocker switch back to the **Arm** position. The PDU display interface will clear the EPO test mode alarm. If the test was not successful, see the troubleshooting chart:

Problem	Action
Neither state LED was red when EPO switch was engaged	<ul style="list-style-type: none"> <li>• Check the wiring to your EPO switch.</li> <li>• Check to make sure the EPO DIP switch configuration is correct for your switch (NO or NC). See step 2 on the previous page for proper configuration instructions.</li> </ul>
Only one of the state LEDs was red when EPO switch was engaged	<ul style="list-style-type: none"> <li>• Check to make sure the EPO DIP switch configuration is correct for your switch (NO or NC) and test again. See step 2 on the previous page for proper configuration instructions.</li> <li>• If the switch is configured correctly and both LEDs are not red after testing again, contact customer support at a number on the back cover of this manual.</li> </ul>

- e. Repeat this test for each EPO switch installed.
4. Ensure that the Arm/Test rocker switch is in the **Arm** position on the monitoring unit.

## **Safety warnings**

EPO can be achieved with either a contact closure or application of an external 24 VAC or 24 VDC from a SELV or PELV source. It's important to note that hazardous voltage from the Mains voltage must be isolated from the contact closure or 24 VAC, 24 VDC. The EPO circuit contact closure, the 24 VAC or the 24 VDC are considered a SELV circuit as defined in EN 60950 *Safety of Information Technology Equipment* or PELV circuit as defined in IEC 60364-4-41 *Electrical Installations of Buildings, Protection for Safety—Protection Against Electric Shock*. SELV is an abbreviation for Safety Extra Low Voltage. PELV is an abbreviation for Protective Extra Low Voltage. SELV and PELV circuits are isolated from the Mains through a safety isolating transformer, and are designed so that under normal conditions the voltage is limited to 42.4 V<sub>peak</sub> or 60 VDC.

# Connect User Input Contacts and Relay Outputs to the User Connection Plate

## Overview

Make contact closure connections (NO or NC) at the user connection plate to monitor dry contacts. You can make eight connections—four input contacts and four relay outputs.

The figure at the right shows the location of the user connection plate on the roof of the PDU enclosure.

You can make connections from inside the enclosure, or you can remove the user connection plate and make your connections.

Remove the plate using a Phillips or standard screw driver to loosen the two captive screws. Use the knockout in the plate to route cables to and from the user connections on the plate. If you remove the plate, make sure that you do not disturb the existing connections.

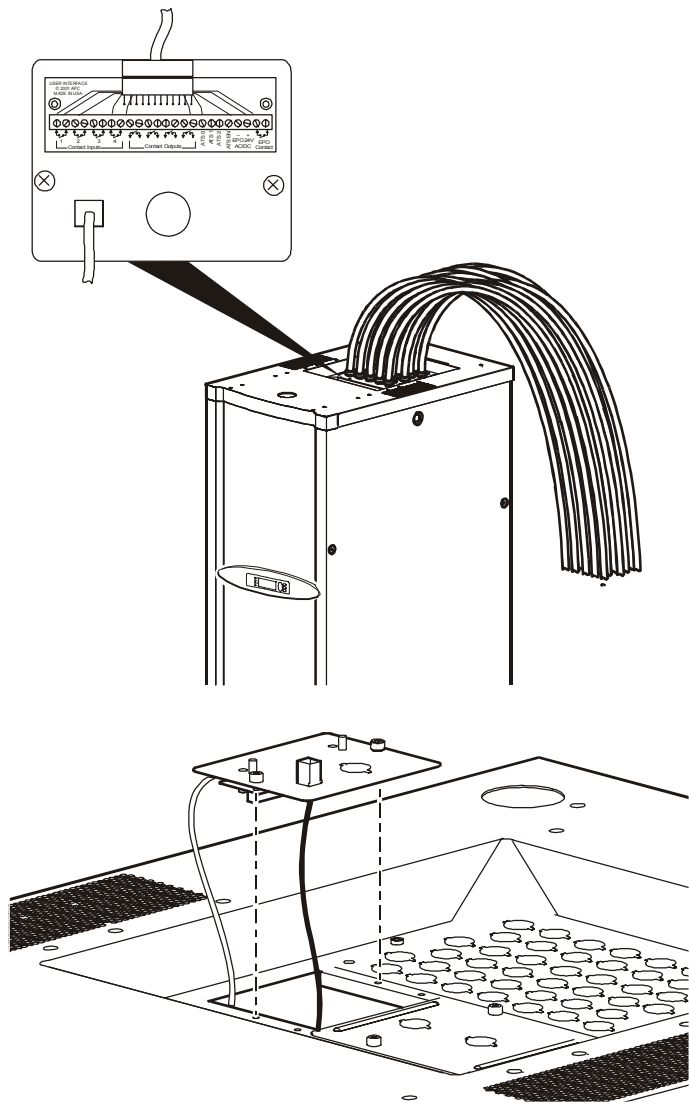



## How to connect contacts to the PDU Monitoring Unit

1. Choose one or more contact numbers on the user connection plate, to which you will connect the contacts. The user connection plate connects to the **User/EPO port** on the PDU monitoring unit.
2. From the PDU display interface:
  - a. Press the ESC or ENTER key to go to the top-level menu screen.
  - b. Select **Contacts** on the top-level menu screen and press the ENTER key.
  - c. Press the ENTER key to select the number of the contact you are connecting. The continue arrow  $\updownarrow$  will appear next to the contact number.
  - d. Press the Up or Down arrow key to select the appropriate contact number and press the ENTER key.
  - e. Press the Down arrow key to enter a unique **Name** for the contact and to configure the **Normal** state of the contact (Open or Closed). The default **Normal** state is Open. Press the ENTER key to select the item you wish to configure.



**Note**

You will be prompted for your password to configure these items.

3. Connect contact wires (300V-rated cabling required) to the terminal block on the user connection plate. You will need a 2.5-mm standard screwdriver.
4. Run the wires from the terminal block out the roof or under the floor of the PDU to your contact's location.



**Warning**

**Ensure that wires are properly retained and away from high voltage lines and breakers.**

### Relay output specifications

Nominal switching capacity	1 A at 30VDC
Maximum switching power	30W
Maximum switching voltage	60VDC
Maximum switching current	2ADC
Maximum carrying current	2ADC
Surge ratings	2kV per Bellcore TA-NWT-001089 1.5kV per FCC part 68

# Install Shielding Troughs, Shielding Partitions, and Cable Ladders

---

## Shielding Troughs and Shielding Partitions for overhead wiring across rows

If you ordered APC Shielding Troughs, Shielding Partitions, and Cable Ladders to route overhead wiring for your system, assemble the Shielding Troughs and the Shielding Partitions along the rows of enclosures and assemble the Cable Ladders between rows.



For information on grounding the Shielding Troughs and Shielding Partitions, see the instruction sheet included with the Shielding Troughs and Shielding Partitions (990-1393B).  
**See also**

**Shielding Troughs.** There are two types of Shielding Troughs:

- The PDU Wide Shielding Trough sits on top of the PDU. The PDU Shielding Trough is two pieces. The power cables sit in between the two pieces when installed on the roof of the PDU.

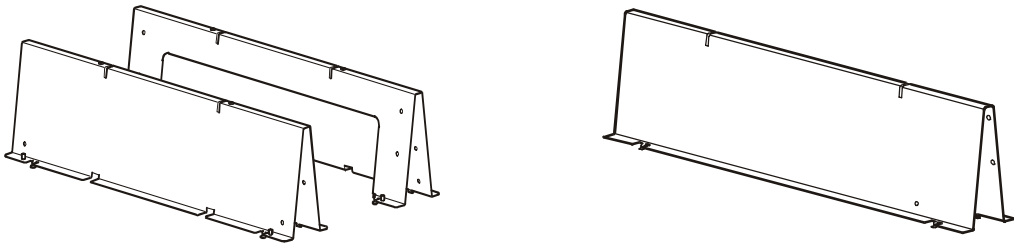

- The NetShelter Shielding Trough is 610mm in length and is not adjustable. The Shielding Troughs have an opening in each side through which you route data cables to the Shielding Partitions.

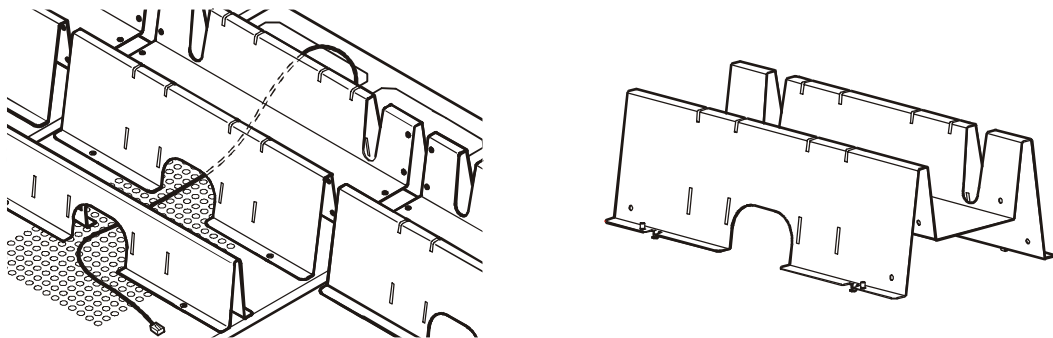

**Shielding Trough accessories.** APC offers the following accessories for Shielding Troughs:

- Shielding Trough Covers for both 600-mm wide (AR8174BLK) and 750-mm wide (AR8175BLK) enclosures. Contact APC for more information.
- Shielding Trough End Caps (AR8167BLK) to place on the side of a Shielding Trough at the end of a row. Contact APC for more information.

**Shielding Partitions.** There are two types of Shielding Partitions, each of which forms a side wall of a trough for data cables. You can customize the width of the trough for each row of your system — wider for rows carrying many data cables, narrower for rows carrying fewer.

- As the back wall, use a Shielding Partition that contains an opening for routing data cables.
- As the front wall, use a solid Shielding Partition to hide data cables for a clean appearance.

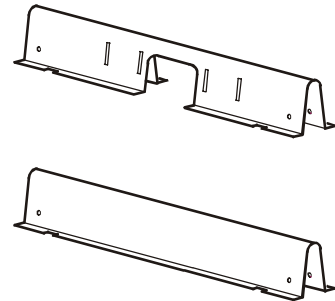

### Cable Ladders for overhead wiring across rows

After installing the Shielding Troughs and Shielding Partitions, install the Cable Ladders between rows of enclosures. You can also run Cable Ladders across Shielding Troughs in the same row, using the hardware provided in the ladder kit.



See also

For more information on installing the Cable Ladders see the instruction sheet included with the cable ladders (990-1576).

Use wide Cable Ladders (12 in; 305 mm) where many power cables or data cables will run between rows; use narrow Cable Ladders (6 in; 152 mm) where few power cables or data cables will run between rows.

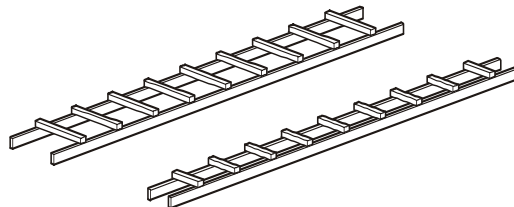

The Cable Ladders are 2946 mm long. You can adjust the length of the Cable Ladders in the following ways:

- Cut the ends with a hacksaw to shorten them.
- Insert the connectors only partially into the side rails to extend them.



Note

Do not change the spacing between rows or the length and position of the Cable Ladders from the layout you planned with your APC representative when you placed your order. For overhead wiring, each PDU power cable is provided at a pre-determined length. Changes to the physical configuration of your system could cause some PDU power cables to be too short or too long.

# Install InfraStruXure Rack-Mount Devices

---

## Install the Rack Automatic Transfer Switches (ATS)

Install a Rack ATS in the top of each enclosure for overhead wiring, and in the bottom of each enclosure for wiring under the floor.



**See also**

See the installation instructions in the manual included with your Rack ATS.

The Rack ATS is an optional component and not all InfraStruXure systems will include them.

## Install the Rack Power Distribution Units (PDU)

Install Rack PDUs in the rear of the NetShelter VX enclosure, in the channel directly behind the rear vertical mounting rails. For overhead wiring, make sure that the power cord is pointing toward the roof of the enclosure. For under the floor wiring, make sure that the power cord is pointing toward the floor.



**See also**

See the installation instructions in the manual included with your Rack PDU.

## Install the InfraStruXure Manager and Hub (or Switch)

Install the InfraStruXure Manager in the enclosure closest to the PDU. The CAT-5 data cables included with your configuration are of varying lengths, based on the distance components will be installed from the PDU.



**See also**

See the installation instructions in the manual included with your InfraStruXure Manager.

## Install the Environmental Monitoring Unit or Environmental Management System

Install the Environmental Monitoring Unit or Environmental Management System according to the installation instructions included with the device. The Environmental Monitoring Unit and Environmental Management System are optional components and not all InfraStruXure systems will include them.

# Route and Attach Overhead Wiring

---

## Route and attach power cables to equipment racks

If you ordered overhead wiring, connect the prewired power cables of the PDU as follows:

1. Install the Shielding Troughs, Shielding Partitions, and Cable Ladders so that you can route power cables from the PDU to the NetShelter VX Enclosures.



**See also**

For installation instructions, see the manual included with your Shielding Troughs, Shielding Partitions, and Cable Ladders.

2. Find the numbers that indicate the enclosure to which each power cable will supply power. These numbers appear on the roof of the PDU where the power cables exit, and on the ends of each power cable.



**Note**

The enclosures are not numbered. Consult your APC InfraStruXure Configure-To-Order (CTO) report to determine the enclosure associated with each power cable.

3. Beginning with the power cables for the enclosures farthest from the PDU, run each power cable within the Shielding Trough along the row and, if necessary, across one or more Cable Ladders to the enclosure to which it will provide power.



**Note**

Ensure that the IEC 309 connector at the end of each power cable always lies on top of any longer power cables in the Shielding Trough.

4. Connect the appropriate power cable to APC power management equipment in the enclosure in one of the four following ways:
  - *For single-feed devices without redundancy:* attach a power cable directly to a Rack PDU installed in a NetShelter VX Enclosure.

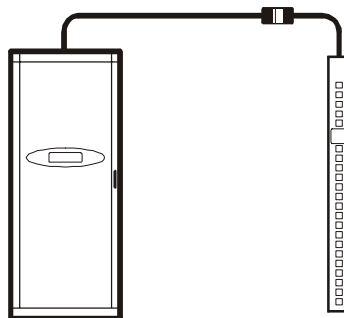

- For dual-feed devices within a redundant system: attach a power cable from each PDU into two different Rack PDUs in the NetShelter VX Enclosure.

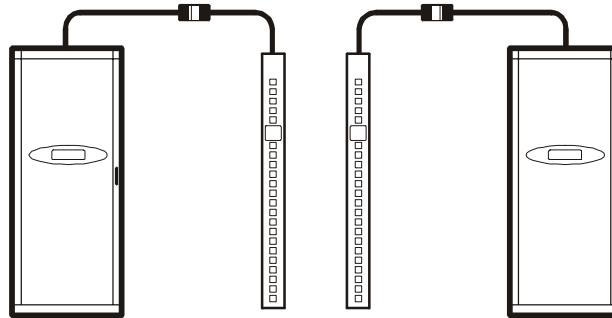

- For single-feed devices within a redundant system with an Automatic Transfer Switch: connect a power cable to the Automatic Transfer Switch (A and B feeds) and connect the Automatic Transfer Switch power cord to a Rack PDU in the NetShelter VX Enclosure.

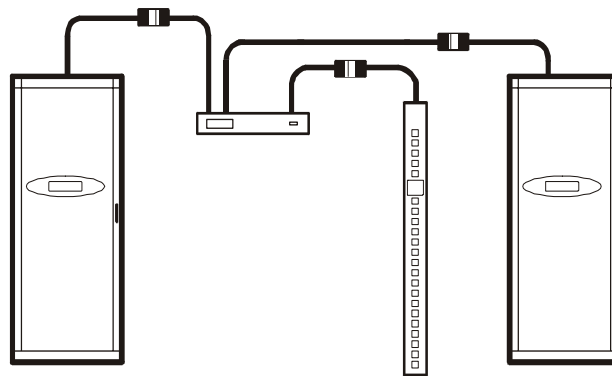

- For dual-feed devices in a redundant system with an Automatic Transfer Switch: connect a power cable from each PDU to the Automatic Transfer Switch's A and B feeds, and another power cable from one PDU to a Rack PDU, and the Automatic Transfer Switch's power cord to a second Rack PDU in the NetShelter VX Enclosure.

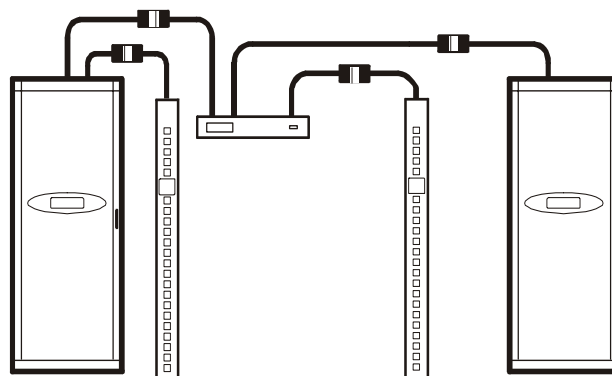

Lay the cables neatly in the Shielding Trough to minimize cable build-up.

Note

5. From each NetShelter VX Enclosure, run the power cable of the appropriate APC power management device out the roof of the enclosure, through the notch in the rear side of the Shielding Trough, to the connector of the appropriate power cable from the PDU. Plug the two connectors together, and twist them clockwise to lock.

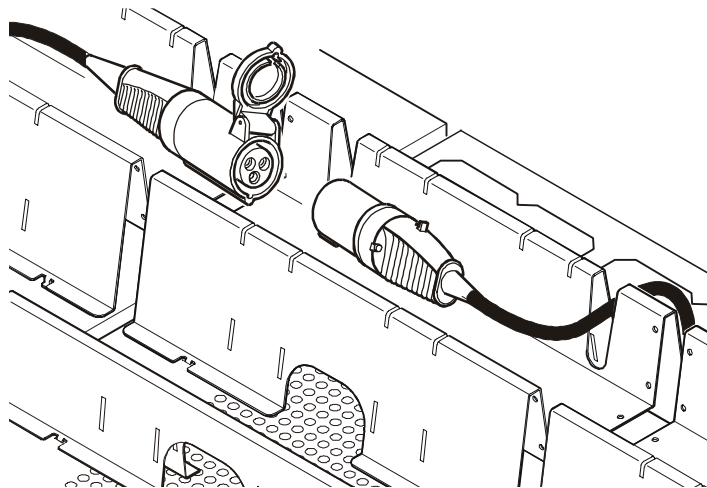

# Wiring Under the Floor

---



A licensed electrician must route and connect the power cables for under-floor wiring.



Make sure all wire connections and circuit breaker connections are properly torqued.

If you are routing power cables to the enclosures under a raised floor, you must provide the appropriate power cables and equipment for installation, and a licensed electrician must route and connect the power cables to the PDU circuit breakers. To wire each power cable to an enclosure:

1. Push out a knock-out filler in the floor of the PDU to create an opening for the cable.
2. From the Rack PDU or Rack ATS in each enclosure, thread the appropriate power cable (for your application) from the enclosure to the PDU.
3. At the PDU, route the cable through the opening you created in step 1 and then up through the wireway (A) at either side of the PDU. This will allow you to connect cable to the upper circuit breaker panel.

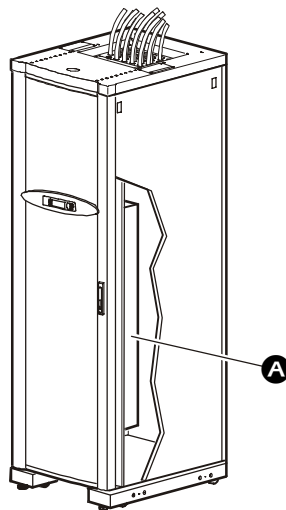



4. At the circuit breaker panel, cut the wires to the proper length, and connect the power cable's individual wires:
  - a. If you have branch current monitoring installed, route each phase conductor through a current sensor. If it is a three-phase cable, route the L1, L2, and L3 wires through a separate current sensor.
  - b. Connect the L1, L2, and L3 wires to the circuit breaker(s). The illustration below shows a single-phase cable connecting to a single-pole breaker; however, you can also connect a three-phase cable to a three-pole breaker.
  - c. Connect the neutral wire to the closest open termination point on the Neutral Bar (N).
  - d. Connect the PE wire to the closest open termination point on the PE Bar (PE).

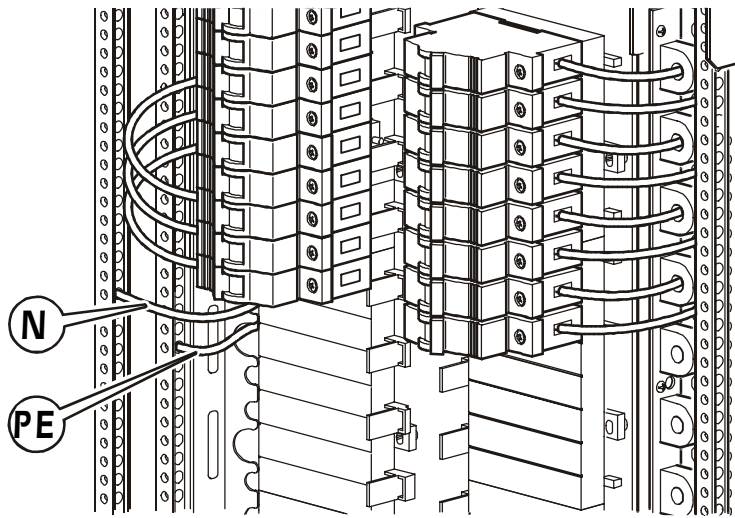

Caution

**Any multi-circuit power cable that is installed by an electrical contractor must be installed with a 3-pole circuit breaker.**

# Route Data Cables to the InfraStruXure Manager Hub (or Switch)

1. Connect a Cat-5 network cable (provided) to the network or 10Base-T ports on your APC InfraStruXure devices. The following devices need to be connected:

## Automatic Transfer Switch

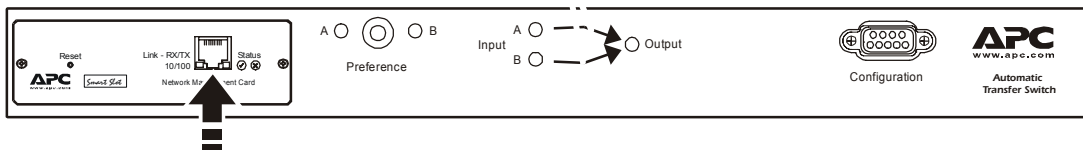

## Environmental Monitoring Unit

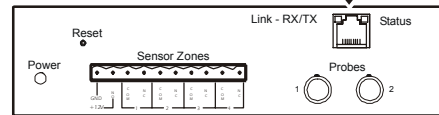

## Rack PDU

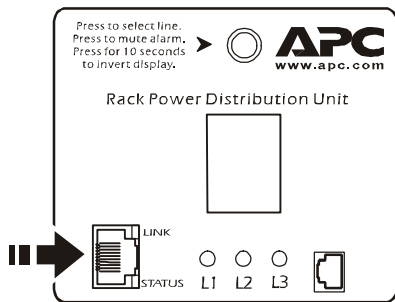

## Symmetra PX UPS

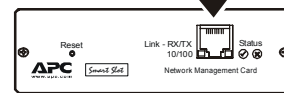

## InfraStruXure PDU

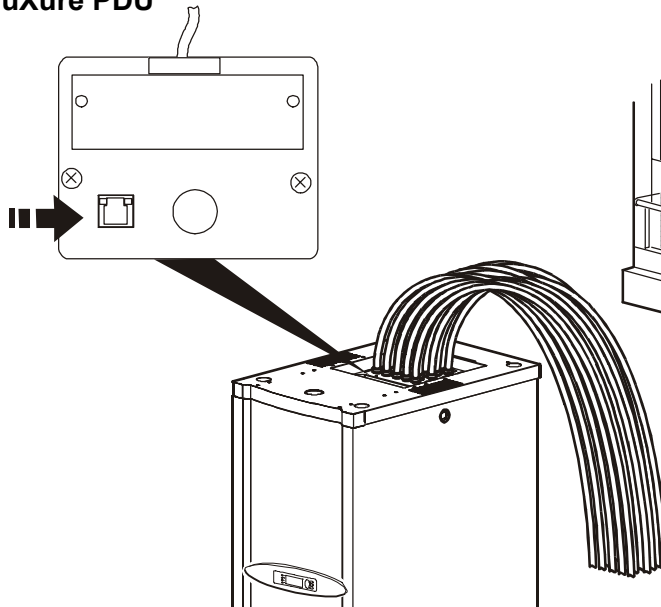

2. Run the connected Cat-5 network cables through the data cable troughs to the InfraStruXure Manager Hub (or Switch).
3. Connect each device's network cable to any available station port in the InfraStruXure Manager Hub (or Switch). Station ports are those with an *x* after the number (e.g., 2*x*).

# Start-Up Procedure

## Safety warnings

This section provides instructions on how to perform a system start-up. Do not skip any steps in this procedure.



**Only APC Field Service Engineers or qualified, APC-trained personnel may perform a system start-up.**



**Before you proceed, ensure that power is off by following the procedure in this section.**

## Ensure that all power is off

1. Open (turn OFF) the PDU **Main Input**.

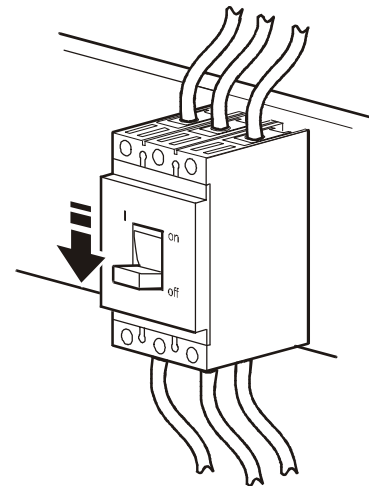

2. Set the upstream input mains (utility or UPS) to the OFF or Locked Out position.

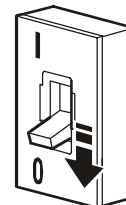

### Apply power to the system

1. Set the upstream mains circuit breaker (utility or UPS) to ON.

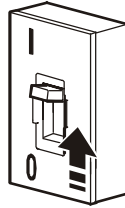

2. Ensure A-B-C clockwise phase rotation at the top of the **Main Input** on the PDU, using a phase rotation meter.
3. Close (turn ON) the **Main Input** on the PDU.

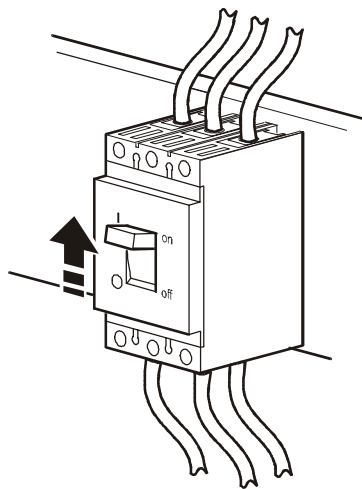

4. Verify A-B-C clockwise phase rotation at the top of the primary winding of the transformer, using a phase rotation meter.
5. Verify that the proper voltage is present on the secondary winding of the transformer (400V, metered phase-to-phase), using a true RMS voltmeter.

6. Close (turn ON) the **Main Output** circuit breaker on the PDU. (Only on PDUs with a transformer.)

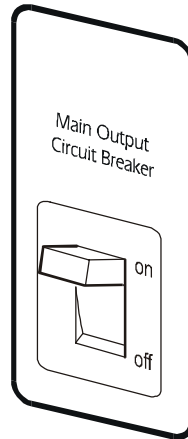

**Note**

When the **Main Output** circuit breaker is closed, the power distribution circuit breaker panels are energized.

7. Close (turn ON) the PDU **distribution panel** circuit breakers.



**Note**

When the **distribution panel** circuit breakers are closed, the PDU power cables and connected equipment are energized.

# Configure the InfraStruXure Manager

---

Configure the InfraStruXure Manager after all of the equipment is installed, the network cables are connected to the InfraStruXure Manager hub (or switch), and start-up of the system is complete.



**See also**

For instructions, see the *InfraStruXure Manager Installation and Quick-Start* manual included with your InfraStruXure Manager.



**Note**

If you use PowerChute Network Shutdown (PCNS) software with your InfraStruXure UPS, your UPS must have a connection to the “User LAN” (public network) for PCNS to function correctly. If the Network Management Card installed in your UPS is connected to the InfraStruXure Manager’s “APC LAN,” you must install a second Network Management Card in your UPS and connect it to the “User LAN” (public network) to use PCNS.

# Appendix A: System Operation

## How to Apply Power to the System

1. Close (turn ON) the main circuit breaker of the **power source** supplying power to the PDU.

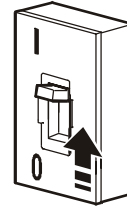

2. Close (turn ON) the **Main Input** on the PDU.

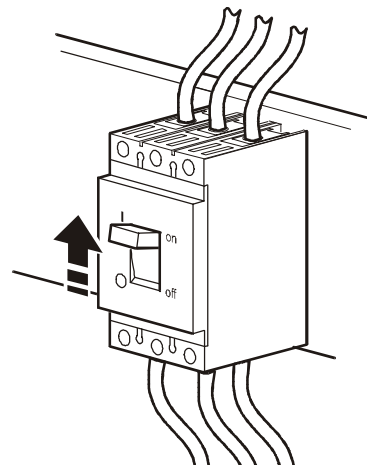

3. Power the *PDU distribution circuit breakers*.

*For PDUs with transformer:*

- a. Set the Main Output circuit breaker on the PDU to ON.

**Note:** After the **Main Output** circuit breaker has been closed, both PDU distribution panels will be energized.

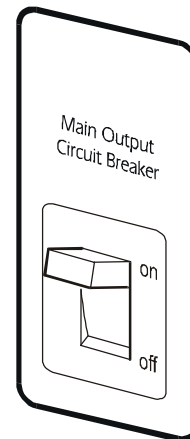

*For PDUs with and without a transformer:*

- b. Close (turn ON) the PDU **distribution panel** circuit breakers.



**Note**

When the **distribution panel** circuit breakers are closed, the PDU power cables and connected equipment are energized.

# How to Ensure Total Power Off

---

1. Open (turn OFF) the main circuit breaker on the **power source** feeding the PDU.

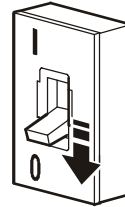

2. Open (turn OFF) the **Main Input** switch on the PDU.

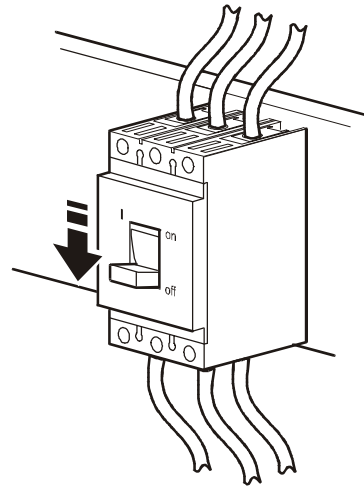

3. *For PDU with transformer:* Set the **Main Output** circuit breaker on the front of the PDU to OFF.

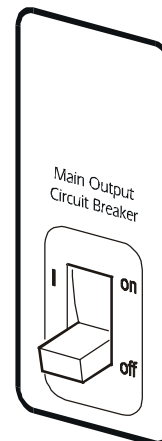



# Appendix B: Changes in this Manual

## Overview

The following list references the specific changes made to this manual since its last release (990-1637A).

## General changes

An index has been added to the end of this manual. See pages 43–44.

## Changes by page number

Pages 18–21	Updated “Connect an Emergency Power Off Switch” instructions.
Pages 22–23	Replaced “Connect User Contacts to the PDU monitoring unit” with “Connect User Input Contacts and Relay Outputs to the User Connection Plate.”



# Index

---

## A

automatic transfer switch,  
installation of, 28

## C

cable ladders, installation of, 27

## E

Emergency Power Off (EPO)

connect the switch, 20–23  
overview, 10  
problems with, 22  
safety warnings, 3

EMI warnings, 3

Environmental Management  
System, installation of, 28

Environmental Monitoring Unit,  
installation of, 28

EPO. See Emergency Power Off  
(EPO).

## H

heat dissipation, 8

## I

InfraStruXure Manager

configure the, 38  
installation of, 28  
route data cables to, 34

InfraStruXure PDU

applying power to, 36–37  
connect the power source  
to, 16–19  
dimensions of, 5  
electrical requirements, 9  
heat dissipation, 8  
level the, 15  
space requirements for  
installing, 6  
weight considerations, 7

installation, 15–34

basic procedure, 11–13  
connect the Emergency Power  
Off switch, 20–23  
connect the power source to the  
PDU, 16–19  
connect user contact inputs and  
output relays to the user  
connection plate, 24–25  
level the PDU and NetShelter  
Enclosures, 15  
of rack-mount devices, 28  
of shielding troughs, shielding  
partitions, and cable  
ladders, 26–27  
route and attach overhead  
wiring, 29–31  
route data cables to the  
InfraStruXure Manager, 34  
tools required, 18  
wiring under the floor, 32–33

## K

keys, for unlocking the PDU back  
door, 16

## M

main input switch, 16, 35–36, 39–  
40  
main output circuit breaker, 37, 39–  
40

maintenance

safety while the PDU is  
receiving input power, 2

## N

NetShelter VX Enclosure

dimensions of, 5  
level the, 15  
weight considerations, 7

## O

operation, 39–40  
applying power to the

system, 39

ensuring total power off, 40

## P

PDU. See InfraStruXure PDU.

PE bar, location of, 33

PE wire, location of, 33

## R

rack power distribution units,  
installation of, 28

relay outputs, connecting, 24–25

## S

safety, 1–3

during start-up, 35

overview, 1

symbols used in this manual, 1  
warnings, 2–3

Emergency Power Off  
(EPO), 3

EMI, 3

for maintenance performed  
while the PDU is receiving  
input power, 2

installation/maintenance, 2

total power off, 2

unpacking/moving, 2

Shielding Partitions

dimensions of, 5

shielding partitions

installation of, 27

Shielding Trough

dimensions of, 5

shielding troughs

installation of, 26

site planning, 5–13

basic installation  
procedure, 11–13

dimensions, 5

electrical requirements and  
specifications, 9

- Emergency Power Off (EPO), 10
- heat output, 8
- space considerations, 6
- weight considerations, 7

space requirements, 6

start-up procedure, 35–38

## **T**

- tools required, 13, 18
- torque specifications, 18
- total power off
  - ensuring, 35, 40
  - warnings, 2

## **U**

- updates
  - in this manual, 41
  - to this manual, i
- user input contacts, connecting, 24–25

## **W**

- warnings, 2–3
  - Emergency Power Off (EPO), 3
  - EMI, 3
  - installation/maintenance, 2
  - total power off, 2
  - unpacking/moving, 2
- weight considerations, 7
- wiring
  - route and attach overhead, 29–31
  - under the floor, 32–33









## APC Worldwide Customer Support

Customer support for this or any other APC product is available at no charge in any of the following ways:

- Visit the APC Web site to access documents in the APC Knowledge Base and to submit customer support requests.
  - **www.apc.com** (Corporate Headquarters)  
Connect to localized APC Web sites for specific countries, each of which provides customer support information.
  - **www.apc.com/support/**  
Global support searching APC Knowledge Base and using e-support.
- Contact an APC Customer Support center by telephone or e-mail.
  - Regional centers:

Direct InfraStruXure Customer Support Line	(1)(877)537-0607 (toll free)
APC headquarters U.S., Canada	(1)(800)800-4272 (toll free)
Latin America	(1)(401)789-5735 (USA)
Europe, Middle East, Africa	(353)(91)702000 (Ireland)
Japan	(0) 3 5434-2021
Australia, New Zealand, South Pacific area	(61) (2) 9955 9366 (Australia)

- Local, country-specific centers: go to **www.apc.com/support/contact** for contact information.

Contact the APC representative or other distributor from whom you purchased your APC product for information on how to obtain local customer support.

Entire contents copyright © 2004 American Power Conversion. All rights reserved. Reproduction in whole or in part without permission is prohibited. APC, the APC logo, NetShelter, InfraStruXure, and Symmetra are trademarks of American Power Conversion Corporation and may be registered in some jurisdictions. All other trademarks, product names, and corporate names are the property of their respective owners and are used for informational purposes only.

