

M90t Gen 5
User Guide

Lenovo
ThinkCentre



Read this first

Before using this documentation and the product it supports, ensure that you read and understand the following:

- *Safety and Warranty Guide*
- [Generic Safety and Compliance Notices](#)
- *Setup Guide*

First Edition (April 2024)

© Copyright Lenovo 2024.

LIMITED AND RESTRICTED RIGHTS NOTICE: If data or software is delivered pursuant to a General Services Administration "GSA" contract, use, reproduction, or disclosure is subject to restrictions set forth in Contract No. GS-35F-05925.

Contents

About this documentation ii

Chapter 1. Meet your computer 1

Front 1
Rear 2
Specifications 4
USB specifications 5
The Vantage app 6

Chapter 2. Get started with your computer 9

Access networks 9
Connect an external display 9
Transfer data 9
Connect to a Bluetooth device 10
 Conventional pair 10
 Swift pair 11
ICE performance mode 11
Smart power-on feature (for selected models) 11
Set the power plan 12
Security 12
 Lock the computer 12
 Smart USB protection 13
 Use software security solutions 14

Chapter 3. UEFI BIOS 15

Enter the UEFI BIOS menu 15
Navigate the UEFI BIOS menu 15
Enable or disable the ErP LPS compliance mode 15
Update the UEFI BIOS 16
 From the Vantage app 16
 From the Lenovo Support Web site 16
 From the Windows Update 16

Chapter 4. CRU replacement 17

CRU list 17

Tool-less storage 18
Dust shield 18
Computer cover 19
Optical drive 20
Front bezel 22
Primary hard disk drives 23
Optical drive cage 26
Secondary hard disk drives 27
M.2 solid-state drive and heat sink 29
M.2 solid-state drive bracket 31
PCI-Express connector cable 32
PCI-Express card 32
Graphics card holder 33
Graphics card 34
Memory module 36
3.5-inch primary hard disk drive cage 38
Power supply assembly 39
E-lock 40
Chassis beam 41

Chapter 5. Help and support 45

Find your serial number 45
Diagnose and troubleshoot your computer 45
 Troubleshoot and diagnose at Lenovo
 Support Web site 46
 Hardware scan 46
Recover your Windows operating system 46
Call Lenovo 47
 Before you contact Lenovo 47
Self-help resources 47
Purchase accessories or additional services 47

Appendix A. Notices and trademarks 49

About this documentation

- This guide applies to the Lenovo product models listed below. Illustrations in this guide may look slightly different from your product model.

Model name	Machine types (MT)
ThinkCentre M90t Gen 5	12V1, 12V2, 12V5, 12V6

- For more compliance information, refer to *Regulatory Notice* at <https://pcsupport.lenovo.com> and *Generic Safety and Compliance Notices* at https://pcsupport.lenovo.com/docs/generic_notices.
- Depending on the model, some optional accessories, features, and software programs might not be available on your computer.
- Depending on the version of the operating systems and programs, some user interface instructions might not be applicable to your computer.
- Documentation content is subject to change without notice. Lenovo makes constant improvements to the documentation of your computer, including this *User Guide*. To get the latest documentation, go to <https://pcsupport.lenovo.com>.
- Microsoft® makes periodic feature changes to the Windows® operating system through Windows Update. As a result, some information in this documentation might become outdated. Refer to Microsoft resources for the latest information.

Chapter 1. Meet your computer

This computer is equipped with an extensive selection of ports, providing convenient connectivity options for multiple devices.

Front

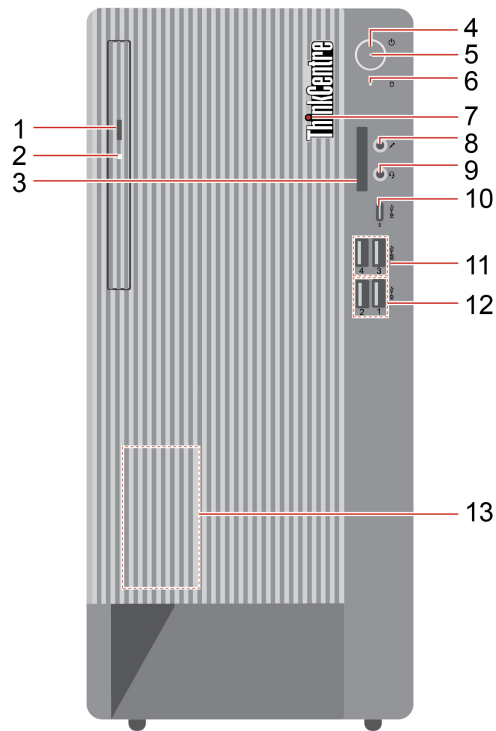

Item	Description	Item	Description
1	Optical drive eject button*	2	Optical drive activity indicator*
3	SD-card slot*	4	Power button
5	Power indicator	6	Storage drive activity indicator
7	ThinkCentre® LED	8	Microphone connector
9	Headset connector	10	USB-C® (3.2 Gen 2) connector
11	USB 3.2 connectors Gen 1	12	USB 3.2 connectors Gen 2
13	Internal speaker		

* for selected models

Statement on USB transfer rate

Depending on many factors such as the processing capability of the host and peripheral devices, file attributes, and other factors related to system configuration and operating environments, the actual transfer rate using the various USB connectors on this device will vary and will be slower than the data rate listed below for each corresponding device.

USB device	Data rate (Gbit/s)
Thunderbolt 3	40
Thunderbolt 4	40

Power indicator

Show the system status of your computer.

- **On:** The computer is starting up or working.
- **Off:** The computer is off or in hibernation mode.
- **Blinking:** The computer is in sleep mode.

Headset connector

The headset connector is compatible with:

- Headphones or earphones with a 3.5mm (0.14 inch), TRS (3-pole) plug
- Headsets with a 3.5mm (0.14 inch), CTIA-compliant TRRS (4-pole) plug

Note: This headset connector does not support standalone external microphones with a TRS (3-pole) plug or headsets with an OMTP-compliant TRRS (4-pole) plug.

Related topics

- “USB specifications” on page 5.

Rear

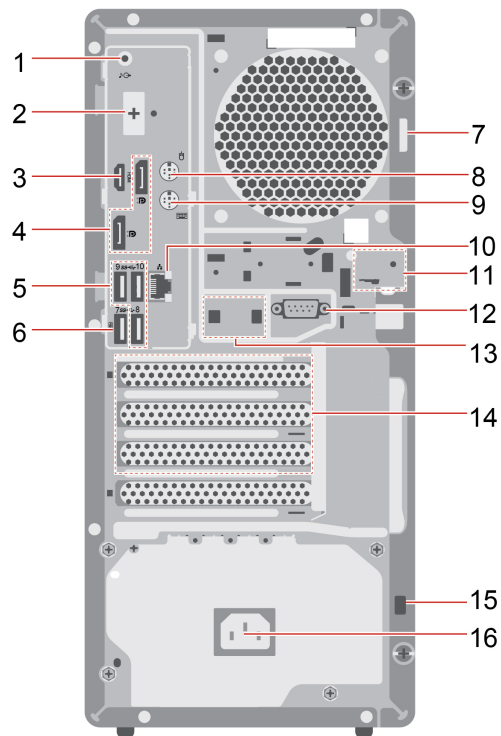

Item	Description	Item	Description
1	Audio line-out connector	2	Optional connector*
3	HDMI™ out connector	4	DisplayPort™ out connectors
5	USB 3.2 connectors Gen 1	6	USB 3.2 connector Gen 1 (with smart power-on feature)
7	Padlock loop	8	PS/2 mouse connector*
9	PS/2 keyboard connector*	10	Ethernet connector
11	E-lock slots	12	Serial connector*
13	Smart cable clip slots	14	PCI-Express card area
15	Security-lock slot	16	Power cord connector

* for selected models

Serial connector

Connect an external modem, a serial printer, or other devices that use a serial connector.

Optional connector

Depending on the computer model, the connector might be a DisplayPort out connector, a USB-C connector, or an HDMI™ out connector.

Related topics

- “Lock the computer” on page 12.
- “Connect an external display” on page 9.
- “USB specifications” on page 5.

Specifications

Specification	Description
Dimensions	<ul style="list-style-type: none">• Width: 170 mm (6.7 inches)• Height: 376 mm (14.8 inches)• Depth: 297.85 mm (11.7 inches)
Weight (without packaging)	Maximum configuration as shipped: 6.5 kg (14.3 lb)
Hardware configuration	Type Device Manager in the Windows search box and then press Enter. Type the administrator password or provide confirmation, if prompted.
Power supply	<ul style="list-style-type: none">• 260-watt automatic voltage-sensing power supply• 300-watt automatic voltage-sensing power supply• 500-watt automatic voltage-sensing power supply
Electrical input	<ul style="list-style-type: none">• Input voltage: From 100 V ac to 240 V ac• Input frequency: 50/60 Hz
Adaptability for power supply	<ul style="list-style-type: none">• Mainland China: 220 V±22 V, 50 Hz±1 Hz• Adaptive voltage positioning: 90 V to 264 V, 50/60 Hz• With voltage selection switch: 90 V to 264 V, 50 Hz±1 Hz
Memory	Up to four double data rate 5 (DDR5) unbuffered dual inline memory modules (UDIMMs) Maximum memory capacity: 128 GB
Storage device	<ul style="list-style-type: none">• 2.5-inch hard disk drive*• 3.5-inch hard disk drive*• M.2 solid-state drive* <p>To view the storage drive capacity of your computer, type Disk Management in the Windows search box and then press Enter.</p> <p>Note: The storage drive capacity indicated by the system is less than the nominal capacity.</p>
Video features	<ul style="list-style-type: none">• The integrated graphics card supports the following:<ul style="list-style-type: none">– DisplayPort out connector– HDMI out connector– VGA-out connector– USB-C (3.2 Gen 1) connector*• The optional discrete graphics card provides an enhanced video experience and extended capabilities.

Specification	Description
Expansion	<ul style="list-style-type: none"> • Card reader* • Memory slots • M.2 solid-state drive Gen 4 slots • Optical drive* • PCI-Express x1 card slots • PCI-Express x16 Gen 4 graphics card slot • PCI-Express card slot (physical link width x16; negotiable link width x4) • Storage drive cages
Network features	<ul style="list-style-type: none"> • Bluetooth* • Ethernet LAN • Wireless LAN*

* for selected models

Operating environment

Maximum altitude (without pressurization)

- Operating: From 0 m (0 ft) to 3048 m (10 000 ft)
- Storage: From 0 m (0 ft) to 12192 m (40 000 ft)

Temperature





- Operating: From 5°C (41°F) to 35°C (95°F)
- Storage:
 - For common desktop computers: From -40°C (-40°F) to 60°C (140°F)
 - For all-in-one desktop computers: From -20°C (-4°F) to 60°C (140°F)





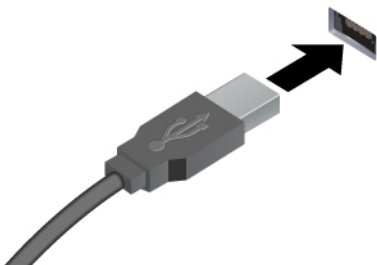

Relative humidity

- Operating: 20%-80% (non-condensing)
- Storage: 10%-90% (non-condensing)

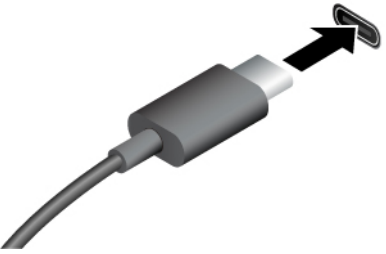
USB specifications

Note: Depending on the model, some USB connectors might not be available on your computer.

Connector name	Description
 <ul style="list-style-type: none"> •  USB-A connector (Hi-Speed USB) •  USB-A connector (USB 5Gbps) •  USB-A connector (USB 10Gbps) 	<p>Connect USB-A compatible devices, such as a USB-A keyboard, USB-A mouse, USB-A storage device, or USB-A printer.</p>

 <ul style="list-style-type: none"> •  USB-C connector (USB 5Gbps) •  USB-C connector (USB 10Gbps) •  USB-C connector (USB4 20Gbps) •  USB-C connector (Thunderbolt 3) •  USB-C connector (Thunderbolt 4) 	<ul style="list-style-type: none"> • Charge USB-C compatible devices with the output voltage and current of 5 V and 3 A. • Connect to an external display: <ul style="list-style-type: none"> – USB-C to VGA: 1920 x 1200 pixels, 60 Hz – USB-C to DP: 3840 x 2160 pixels, 60 Hz • Connect to USB-C accessories to help expand your computer functionality. To purchase USB-C accessories, go to https://www.lenovo.com/accessories.
---	---

The Vantage app

The Vantage app is a customized one-stop solution to help you maintain your computer with automated updates and fixes, configure hardware settings, and get personalized support.

To access the Vantage app, type Vantage in the Windows search box.

Notes:

- The available features vary depending on the computer model.
- The Vantage app makes periodic updates of the features to keep improving your experience with your computer. The description of features might be different from that on your actual user interface. You can download the latest version of Vantage app from Microsoft Store.

The Vantage app enables you to:

- Know the device status easily and customize device settings.
- Download and install UEFI BIOS, firmware, and driver to keep your computer up-to-date.
- Monitor your computer health, and secure your computer against outside threats.

- Scan your computer hardware and diagnose hardware problems.
- Look up warranty status (online).
- Access *User Guide* and helpful articles.

Chapter 2. Get started with your computer

Access networks

This section helps you connect to a wireless or wired network.

Connect to Wi-Fi networks (for selected models)

Click the network icon  on the bottom right of your display to connect to an available network. Provide required information, if needed.

Note: The wireless LAN module on your computer may support different standards. For some countries or regions, use of 802.11ax may be disabled according to local regulations.

Connect to the wired Ethernet

Connect your computer to a local network through the Ethernet connector on your computer with an Ethernet cable.

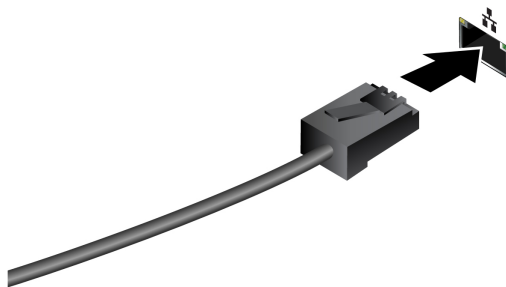

Connect an external display

Connect a projector or a monitor to your computer to give presentations or expand your workspace.

Change display settings

1. Right-click a blank area on the desktop and select display settings.
2. Select the display that you want to configure and change display settings of your preference.

Transfer data

You can install a disc or media card to transfer data.

Use the optical drive (for selected models)

If your computer has an optical drive, read the following information.

Know the type of your optical drive

1. Type Device Manager in the Windows search box and then press Enter. Type the administrator password or provide confirmation, if prompted.
2. Select an optical drive, and then follow the on-screen instructions.

Install or remove a disc

1. With the computer on, press the eject button on the optical drive. The tray slides out of the drive.
2. Insert a disc into the tray or remove a disc from the tray, and then push the tray back into the drive.

Note: If the tray does not slide out of the drive when you press the eject button, turn off the computer. Then, insert a straightened paper clip into the emergency-eject hole adjacent to the eject button. Use the emergency eject only in an emergency.

Record a disc

1. Insert a recordable disc into the optical drive that supports recording.
2. Do one of the following:
 - Type AutoPlay in the Windows search box and then press Enter. Turn on **Use AutoPlay for all media and devices**.
 - Open Windows Media Player.
 - Double-click the ISO file.
3. Follow the on-screen instructions.

Use a media card (for selected models)

If your computer has a SD-card slot, read the following information.

Install a media card

1. Locate the SD-card slot.
2. Ensure that the metal contacts on the card are facing the ones in the SD-card slot. Insert the card firmly into the SD-card slot until it is secured in place.

Remove a media card

Attention: Before removing the card:

1. Click the triangular icon in the Windows notification area to show hidden icons. Right-click the icon prompting you to safely remove hardware and eject media.
2. Select the corresponding item to eject the card from the Windows operating system.
3. Press the card and remove it from your computer. Store the card safely for future use.

Connect to a Bluetooth device

You can connect all types of Bluetooth-enabled devices to your computer, such as a keyboard, a mouse, a smartphone, or speakers. To ensure successful connection, place the devices at most 10 meters (33 feet) from the computer.

Conventional pair

This topic helps you connect to a Bluetooth device by conventional pair.

- Step 1. Type Bluetooth in the Windows search box and then press Enter.
- Step 2. Turn on both the Bluetooth on your computer and the Bluetooth device. Make sure the device is discoverable.
- Step 3. Select the device when it is displayed on the **Add a device** list, and then follow the on-screen instructions.

Notes: If the Bluetooth connection failed, do the following:

1. Type Device Manager in the Windows search box and then press Enter.
2. Locate the Bluetooth adapter. Right-click and select **Update driver**.
3. Select **Search automatically for drivers**, and then follow the on-screen instructions.

Swift pair

This topic helps you connect to a Bluetooth device by swift pair.

If your Bluetooth device supports swift pair, do the following:

- Step 1. Enable swift pair notification on Bluetooth settings page.
- Step 2. Turn on both the Bluetooth on your computer and the Bluetooth device. Make sure the device is discoverable.
- Step 3. Click **Connect** when a swift pair notification appears on your computer.

Notes: If the Bluetooth connection failed, do the following:

1. Type Device Manager in the Windows search box and then press Enter.
2. Locate the Bluetooth adapter. Right-click and select **Update driver**.
3. Select **Search automatically for drivers**, and then follow the on-screen instructions.

ICE performance mode

The ICE performance mode helps you adjust the acoustic and thermal performance of your computer. Three options are available:

- **Balance mode:** The computer works at the balance mode with balanced noise and better performance.
- **Performance mode** (default setting): The computer works at the best performance with normal acoustic level.

Note: The term “best” only refers to the best effect among different settings of the product itself.

- **Full Speed:** All fans in the computer will run at full speed.

Change the ICE performance mode

To change the ICE performance mode:

- Step 1. Restart the computer. When the logo screen is displayed, press F1 or Fn+F1.
- Step 2. Select **Power → Intelligent Cooling** and press Enter.
- Step 3. Select **Performance Mode** and press Enter.
- Step 4. Set the performance mode as desired.
- Step 5. Press F10 or Fn+F10 to save the changes and exit.

Smart power-on feature (for selected models)

The smart power-on feature helps you start up or wake up the computer from the hibernation mode simply by pressing Alt+P.

Note: Ensure that the keyboard is connected to a USB connector supporting the smart power-on feature.

Enable or disable the smart power-on feature

To enable or disable the smart power-on feature:

- Step 1. Restart the computer. When the logo screen is displayed, press F1 or Fn+F1.
- Step 2. Select **Power** → **Smart Power On** and press Enter.
- Step 3. Enable or disable the feature as desired.
- Step 4. Press F10 or Fn+F10 to save the changes and exit.

Set the power plan

For ENERGY STAR® compliant computers, the following power plan takes effect when your computers have been idle for a specified duration:

- Turn off the display: After 10 minutes
- Put the computer to sleep: After 25 minutes

To awaken the computer from Sleep mode, press any key on your keyboard.

To set the power plan:

1. Type **Power Options** in the Windows search box and then press Enter.
2. Choose or customize a power plan of your preference.

Security

This computer offers a wealth of security measures to protect both the device and data safety.

Lock the computer

Note: Lenovo makes no comments, judgments, or warranties about the function, quality, or performance of the locking device and security feature. You can purchase computer locks from Lenovo.

Padlock

Locking the computer cover through a padlock prevents unauthorized access to the inside of your computer.

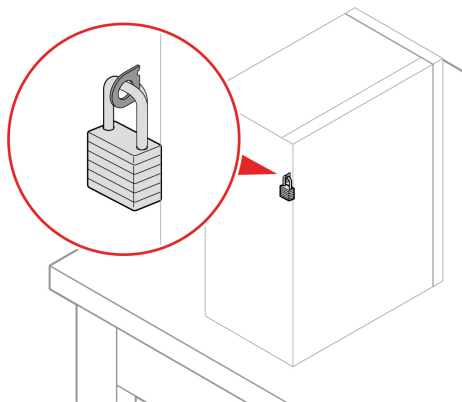

Security lock

Lock your computer to a desk, table, or other fixtures through a security lock.

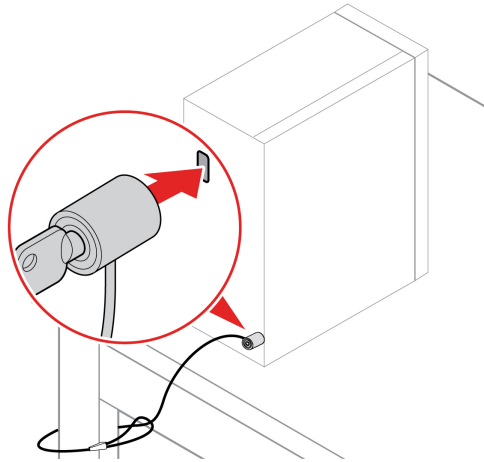

E-lock

Your computer might have a security lock solution installed to protect the computer from unauthorized tampering of the internal components. Using the E-Lock, you can mechanically lock or unlock the computer cover.

To enable or disable the E-Lock:

1. Restart the computer. When the logo screen is displayed, press F1 or Fn+F1.
2. Select **Security** → **Electronic Lock** to enable or disable the E-lock.
3. Press F10 or Fn+F10 to save the changes and exit. Your computer will restart automatically and then changes take effect.

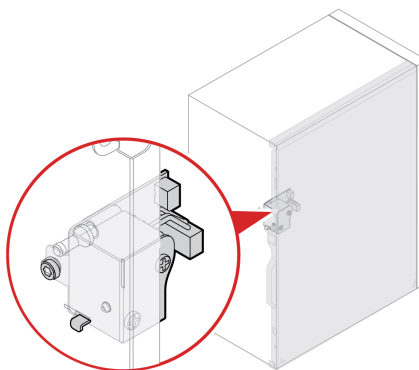

Smart USB protection

The Smart USB Protection function is a security function that helps prevent data from being copied from the computer to USB storage devices connected to the computer. You can set the Smart USB Protection function to one of the following modes:

- **Disabled** (default setting): You can use the USB storage devices without limitation.
- **Read Only**: You cannot copy data from the computer to the USB storage devices. However, you can access data on the USB storage devices.
- **No Access**: You cannot access the USB storage devices from the computer.

To configure the Smart USB Protection function:

1. Restart the computer. When the logo screen is displayed, press F1 or Fn+F1.
2. Select **Security** → **Smart USB Protection** and press Enter.
3. Select the desired setting and press Enter.
4. Press F10 or Fn+F10 to save the changes and exit.

Use software security solutions

The following software solutions help secure your computer and information.

- **Windows Security**

Windows Security is a software built-in to the operating system. It continually scans for malicious software, viruses, and other security threats. Besides, Windows updates are downloaded automatically to help keep your computer safe. Windows Security also enables you to manage tools including firewall, account protection, application and browser control, and so on.

- **Antivirus programs**

Lenovo preinstalls a full-version antivirus software on selected models of computer. It helps defend the computer against viruses, safeguard your identity, and keep your personal information secured.

- **Absolute Persistence**

Absolute Persistence technology is embedded in firmware. It detects changes that happen on the hardware, software, or the call-in location. It keeps you always knowing what condition the computer is in. To activate the technology, you have to purchase a subscription to Absolute.

Note: For more information about how to use these software solutions, refer to their help systems respectively.

Chapter 3. UEFI BIOS

Enter the UEFI BIOS menu

Turn on or restart the computer. When the logo screen is displayed, press F1 or Fn+F1 to enter the UEFI BIOS menu.

Note: If you have set UEFI BIOS passwords, enter the correct passwords when prompted. You also can select **No** or press Esc to skip the password prompt and enter the UEFI BIOS menu. However, you cannot change the system configurations that are protected by passwords.

Navigate the UEFI BIOS menu

Follow the on-screen instructions to navigate in the UEFI BIOS menu.

The table below introduces the available settings of the UEFI BIOS menu. You can follow the on-screen instruction to navigate in the UEFI BIOS menu.

Note: The UEFI BIOS menu might vary depending on system configurations.

Menu	Introduction
Main	This category provides the general product-related and firmware information including system summary, machine type, product serial number, UUID number, etc.
Devices	This category introduces how to configure various devices such as USB ports and audio controllers.
Advanced	This category provides advanced information about the computer such as the CPU features.
Power	This category introduces power and thermal management solutions.
Security	This category introduces various passwords, locks, and software to protect your computer.
Startup	This category introduces how to set the boot priority order.
Exit	This category introduces how to exit as you prefer.

You can go to Lenovo BIOS Simulator Center <https://download.lenovo.com/bsco/index.html> to explore the detailed settings by your product name.

Note: The Lenovo BIOS Simulator Center makes periodic updates of the settings. The UEFI BIOS simulator interface and description of settings might be different from that on your actual user interface.

Enable or disable the ErP LPS compliance mode

Lenovo computers meet the eco-design requirements of the ErP Lot 3 regulation. Follow the instruction to enable or disable the ErP LPS compliance mode.

For more information about the eco-design requirements, go to: <https://www.lenovo.com/us/en/compliance/eco-declaration>.

You can enable the ErP LPS compliance mode to reduce the consumption of electricity when the computer is off. To enable or disable the ErP LPS compliance mode:

Step 1. Restart the computer. When the logo screen is displayed, press F1 or Fn+F1.

Step 2. Select **Power** → **Enhanced Power Saving Mode** and press Enter.

Step 3. Enable or disable the feature as desired.

Note: Please note that when the Enhanced Power Saving Mode is disabled, the power consumption might be increased when the computer is off.

Step 4. Press F10 or Fn+F10 to save the changes and exit.

When the ErP LPS compliance mode is enabled, you can wake up the computer by doing one of the following:

- Press the power button.
- Enable the Wake Up on Alarm feature to make the computer wake up at a set time.

To meet the requirement of ErP compliance, you need to disable the Fast Startup function.

1. Go to **Control Panel** and view by large icons or small icons.
2. Click **Power Options** → **Choose what the power buttons do** → **Change settings that are currently unavailable**.
3. Clear the **Turn on fast startup (recommended)** option from the **Shutdown settings** list.

Update the UEFI BIOS

When you install a new program, device driver, or hardware component, you might need to update the UEFI BIOS.

Download and install the latest UEFI BIOS update package by one of the following methods:

From the Vantage app

Follow the instructions to update the UEFI BIOS from the Vantage app.

Step 1. Open the Vantage app, and then click **Device** → **System Update**.

Step 2. If the latest UEFI BIOS update package is available, follow the on-screen instructions to download and install the package.

From the Lenovo Support Web site

Follow the instructions to update the UEFI BIOS from the Lenovo Support Web site.

Step 1. Go to <https://pcsupport.lenovo.com> and select the entry for your computer.

Step 2. Click **Drivers & Software** → **Manual Update** → **BIOS/UEFI**.

Step 3. Follow the on-screen instructions to download and install the latest UEFI BIOS update package.

From the Windows Update

Follow the instructions to update the UEFI BIOS from the Windows Update.

Step 1. Type Settings in the Windows search box and press Enter.

Step 2. Click **Update & Security** → **Windows Update** → **Check for Updates**.

Step 3. If a BIOS update package appears in your update list, click **Download or Install** to initiate the update.

Chapter 4. CRU replacement

Customer Replaceable Units (CRUs) are parts that can be replaced by the customer. Lenovo computers contain the following types of CRUs:

- **Self-service CRUs:** Refer to parts that can be replaced easily by customer themselves or by trained service technicians at an additional cost.
- **Optional-service CRUs:** Refer to parts that can be replaced by customers with a greater skill level. Trained service technicians can also provide service to replace the parts under the type of warranty designated for the customer's machine.

If you intend on installing the CRU, Lenovo will ship the CRU to you. CRU information and replacement instructions are shipped with your product and are available from Lenovo at any time upon request. You might be required to return the defective part that is replaced by the CRU. When return is required: (1) return instructions, a prepaid shipping label, and a container will be included with the replacement CRU; and (2) you might be charged for the replacement CRU if Lenovo does not receive the defective CRU within thirty (30) days of your receipt of the replacement CRU. For full details, see the Lenovo Limited Warranty documentation at:

https://www.lenovo.com/warranty/llw_02

CRU list

The following is the CRU list of your computer.

Self-service CRUs

- Chassis beam
- Computer cover
- Dust shield*
- Front bezel
- Graphics card*
- Graphics card holder*
- Keyboard*
- Kensington-style cable lock*
- M.2 solid-state drive*
- M.2 solid-state drive bracket*
- M.2 solid-state drive heat sink*
- Memory module
- Mouse*
- Optical drive*
- Optical drive bracket*
- Optical drive cage*
- PCI-Express card*
- PCI-Express connector cable*
- Power cord
- Primary hard disk drive*

- Primary hard disk drive bracket*
- Primary hard disk drive cage*
- Secondary hard disk drive*
- Secondary hard disk drive bracket*
- Secondary hard disk drive cage*
- Storage hard disk converter*

Optional-service CRUs

- E-lock*
- Power supply assembly

* for selected models

Tool-less storage

You can remove or replace the storage devices of this computer without tools.

Related topics

- “Primary hard disk drives” on page 23.
- “Secondary hard disk drives” on page 27.
- “M.2 solid-state drive and heat sink” on page 29.

Dust shield

Prerequisite

Before you start, read *Generic Safety and Compliance Notices*, and print the following instructions.



Before you open the computer cover, turn off the computer and wait several minutes until the computer is cool.

Removal steps

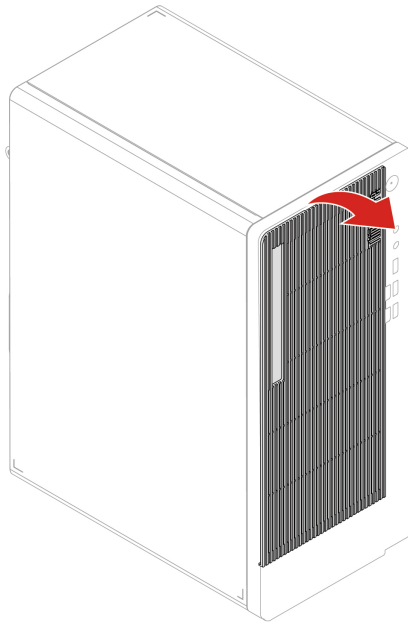

Computer cover

Prerequisite

Before you start, read *Generic Safety and Compliance Notices*, and print the following instructions.



Before you open the computer cover, turn off the computer and wait several minutes until the computer is cool.

For access, do the following:

1. Remove any media from the drives and turn off all connected devices and the computer.
2. Disconnect all power cords from electrical outlets and disconnect all cables from the computer.
3. Unlock any locking device that secures the computer cover.
4. Lay down the computer to place the computer cover facing up.

Removal steps

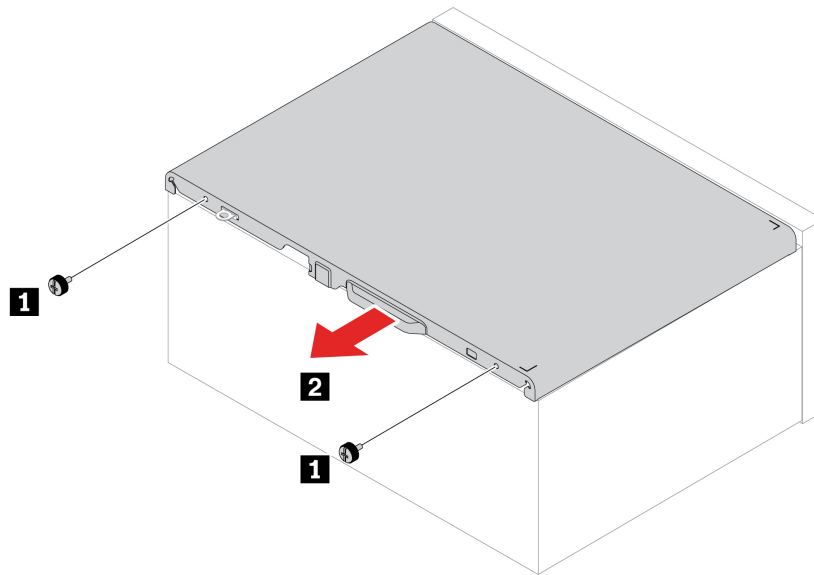

Note: If a locking device is available, use it to lock the computer after installing the computer cover.

Screw (quantity)	Torque
Thumb or 6-#32 (2)	3.0 ± 0.5 lb/in

Optical drive

Prerequisite

Before you start, read *Generic Safety and Compliance Notices*, and print the following instructions.

For access, do the following:

1. Remove the “Computer cover” on page 19.
2. Disconnect the signal and power cable from the optical drive.

Removal steps

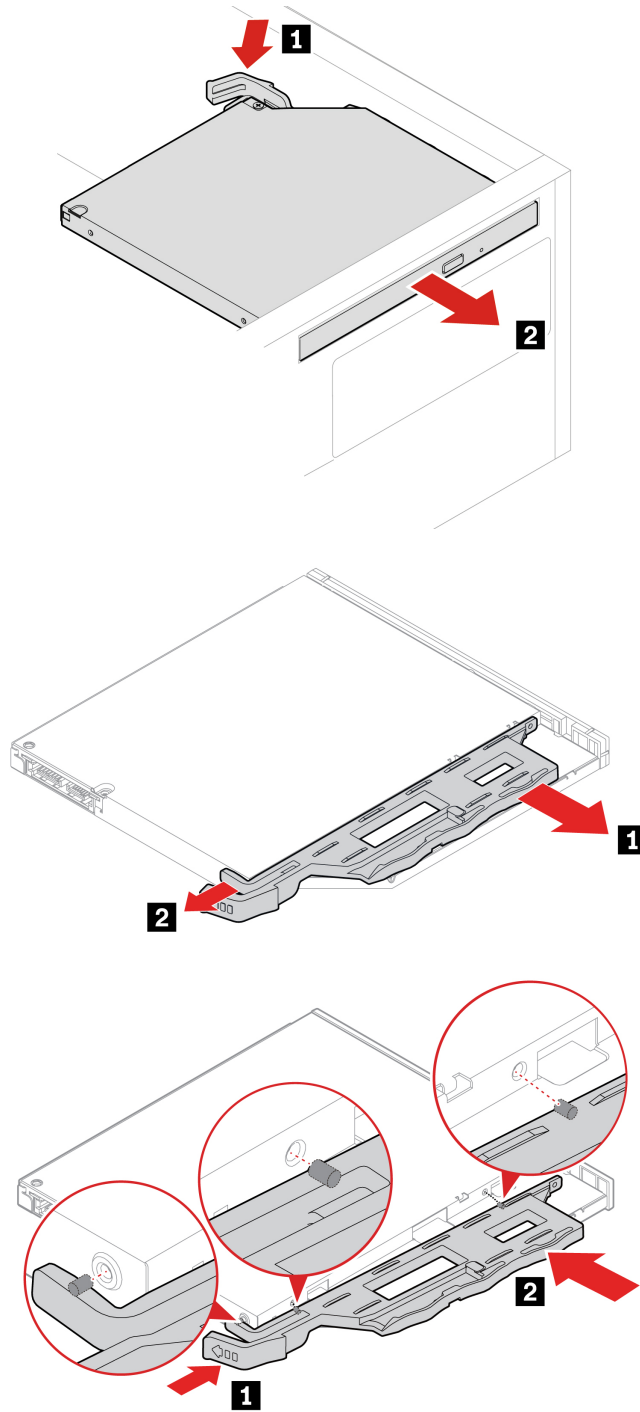

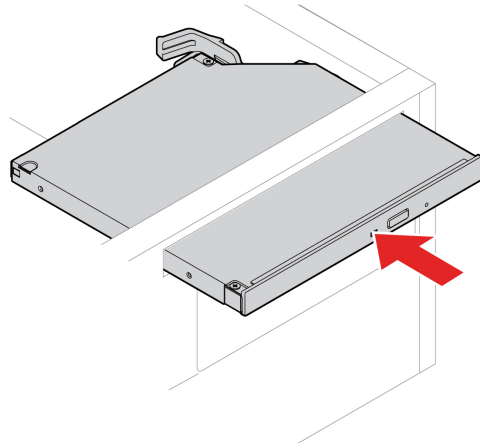

Front bezel

Prerequisite

Before you start, read *Generic Safety and Compliance Notices*, and print the following instructions.

For access, remove these parts in order, if any:

- “Computer cover” on page 19
- “Optical drive” on page 20

.

Replacement procedure

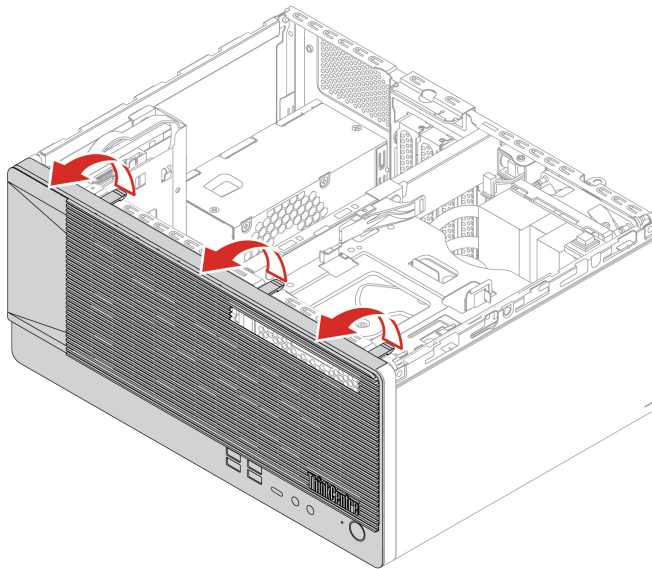

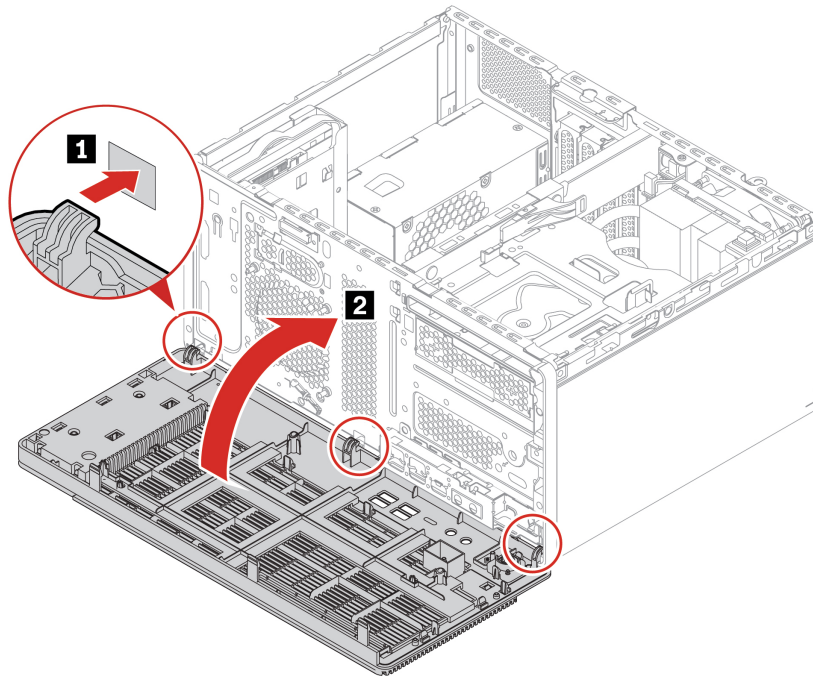

Primary hard disk drives

Prerequisite

Before you start, read *Generic Safety and Compliance Notices*, and print the following instructions.

Attention: The internal storage drive is sensitive. Inappropriate handling might cause damage and permanent loss of data. When handling the internal storage drive, observe the following guidelines:

- Replace the internal storage drive only for upgrade or repair. The internal storage drive is not designed for frequent changes or replacement.
- Before replacing the internal storage drive, make a backup copy of all the data that you want to keep.
- Do not touch the contact edge of the internal storage drive. Otherwise, the internal storage drive might get damaged.
- Do not apply pressure to the internal storage drive.
- Do not make the internal storage drive subject to physical shocks or vibration. Put the internal storage drive on a soft material, such as cloth, to absorb physical shocks.

Removal steps of the 3.5-inch primary hard disk drive and bracket

1. Remove the “Computer cover” on page 19.
2. Disconnect the signal cable and the power cable from the 3.5-inch primary hard disk drive.
3. Remove the 3.5-inch primary hard disk drive and bracket.

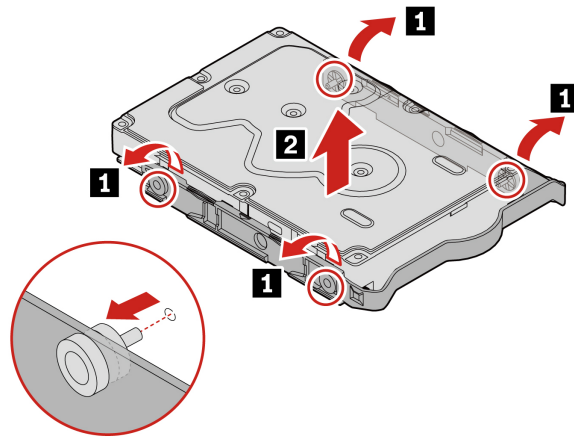
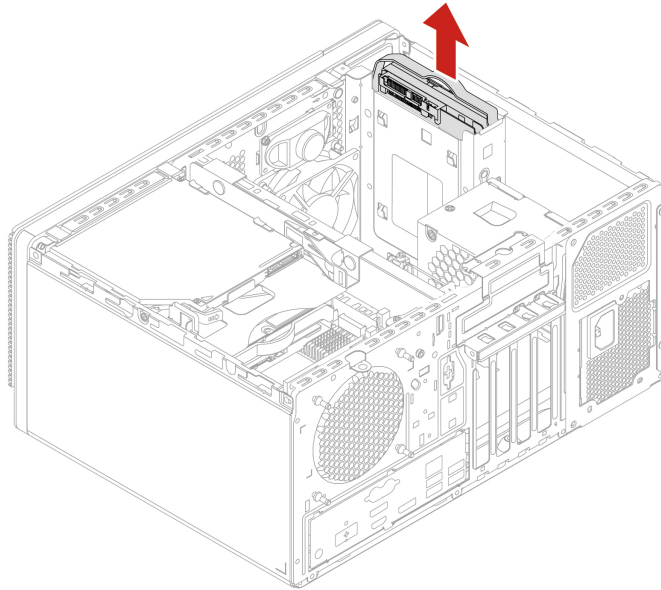

Removal steps of the 2.5-inch primary hard disk drive, converter, and bracket

1. Remove the “Computer cover” on page 19.
2. Disconnect the signal cable and the power cable from the 2.5-inch primary hard disk drive.
3. Remove the 2.5-inch primary hard disk drive, converter, and bracket.

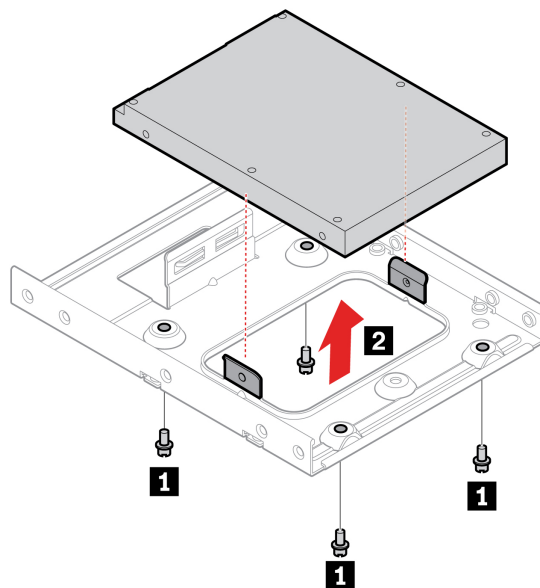
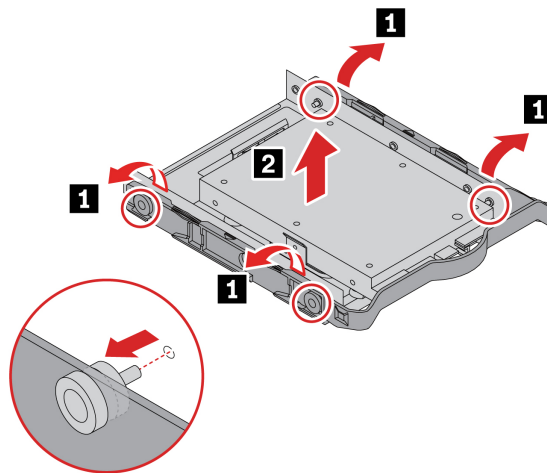
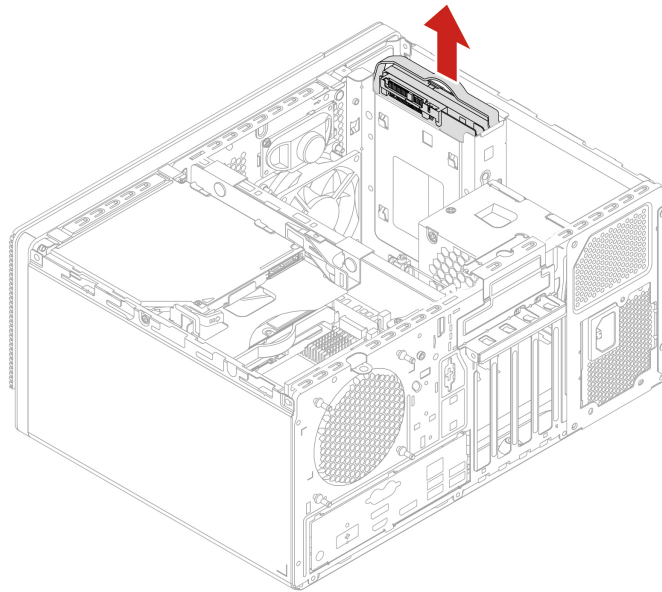

Screw (quantity)	Torque
M3 x 3.75 mm, Phillips Head (4)	5.0 ± 0.5 lb/in

Optical drive cage

Prerequisite

Before you start, read *Generic Safety and Compliance Notices*, and print the following instructions.

For access, do the following:

1. Remove these parts in order, if any:
 - “Computer cover” on page 19
 - “Optical drive” on page 20
 - “Front bezel” on page 22
2. Disconnect the signal cable and power cable (if any) from the secondary hard disk drive under the optical drive cage.

Replacement procedure

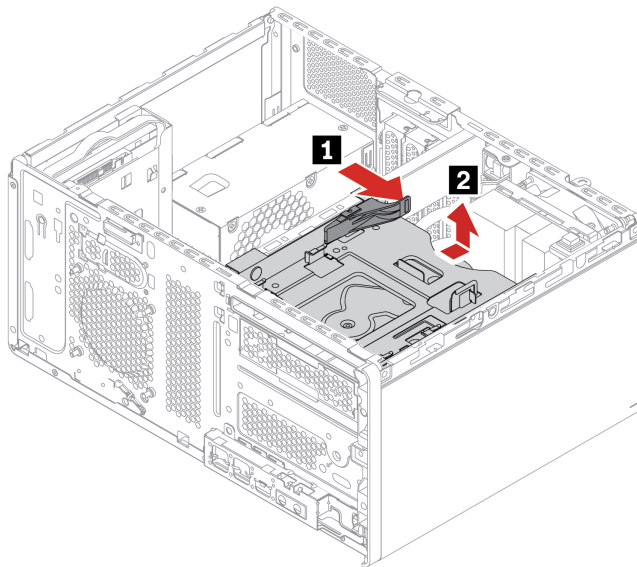

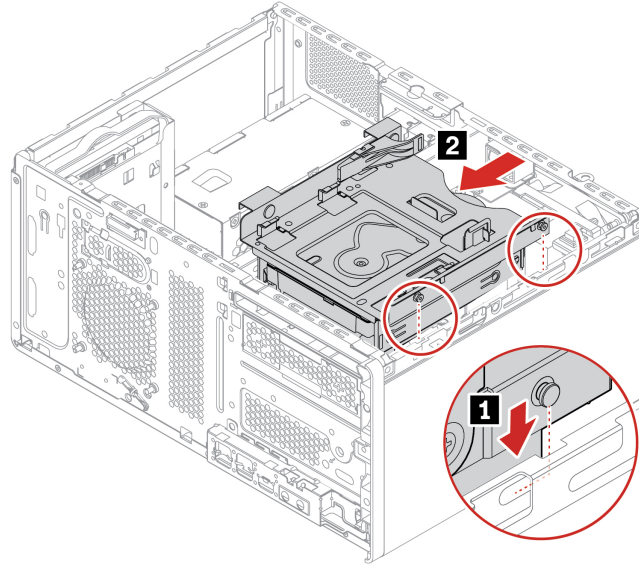

Secondary hard disk drives

Prerequisite

Before you start, read *Generic Safety and Compliance Notices*, and print the following instructions.

Attention: The internal storage drive is sensitive. Inappropriate handling might cause damage and permanent loss of data. When handling the internal storage drive, observe the following guidelines:

- Replace the internal storage drive only for upgrade or repair. The internal storage drive is not designed for frequent changes or replacement.
- Before replacing the internal storage drive, make a backup copy of all the data that you want to keep.
- Do not touch the contact edge of the internal storage drive. Otherwise, the internal storage drive might get damaged.
- Do not apply pressure to the internal storage drive.
- Do not make the internal storage drive subject to physical shocks or vibration. Put the internal storage drive on a soft material, such as cloth, to absorb physical shocks.

For access, remove these parts in order, if any:

- “Computer cover” on page 19
- “Optical drive” on page 20
- “Front bezel” on page 22
- “Optical drive cage” on page 26

Removal steps of the 2.5-inch secondary storage drive, bracket, and cage

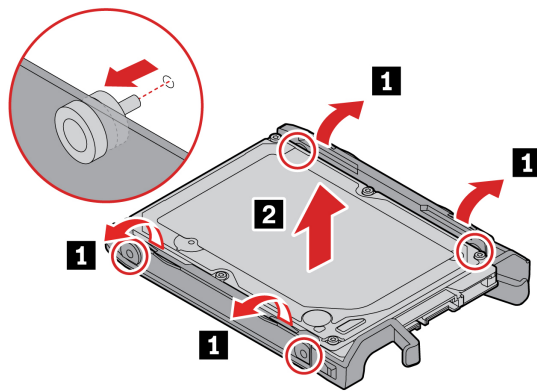
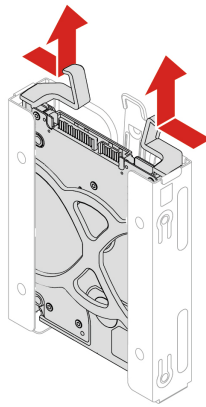
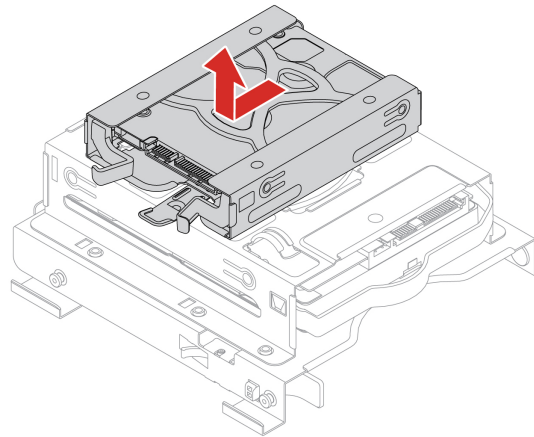

Removal steps of the 3.5-inch secondary storage drive, plastic bracket, and cage

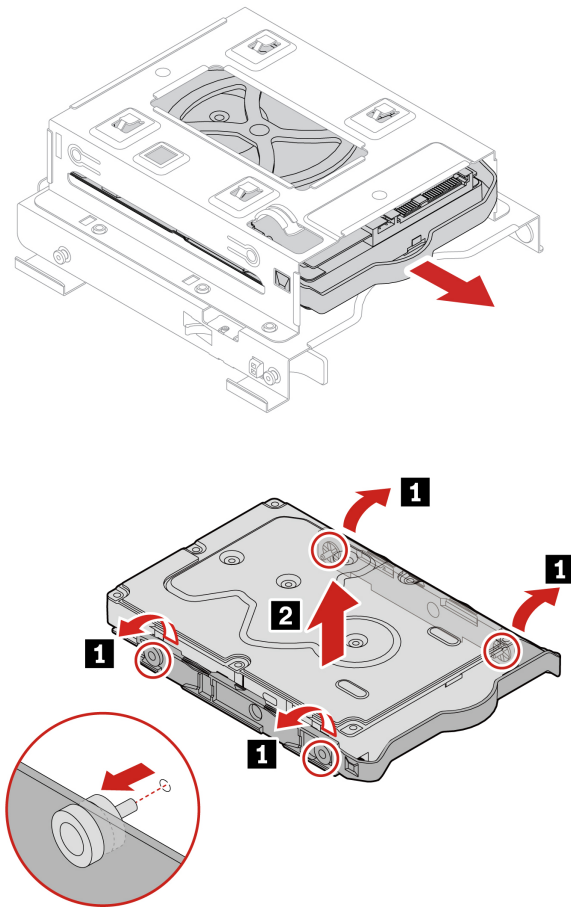

M.2 solid-state drive and heat sink

Prerequisite

Before you start, read *Generic Safety and Compliance Notices*, and print the following instructions.



Before you open the computer cover, turn off the computer and wait several minutes until the computer is cool.

Attention: The internal storage drive is sensitive. Inappropriate handling might cause damage and permanent loss of data. When handling the internal storage drive, observe the following guidelines:

- Replace the internal storage drive only for upgrade or repair. The internal storage drive is not designed for frequent changes or replacement.
- Before replacing the internal storage drive, make a backup copy of all the data that you want to keep.
- Do not touch the contact edge of the internal storage drive. Otherwise, the internal storage drive might get damaged.
- Do not apply pressure to the internal storage drive.

- Do not make the internal storage drive subject to physical shocks or vibration. Put the internal storage drive on a soft material, such as cloth, to absorb physical shocks.

For access, remove the “Computer cover” on page 19.

Removal steps

Remove the M.2 solid-state drive and the heat sink (if any) depending on the computer model.

- For computers without the heat sink for the M.2 solid-state drive:

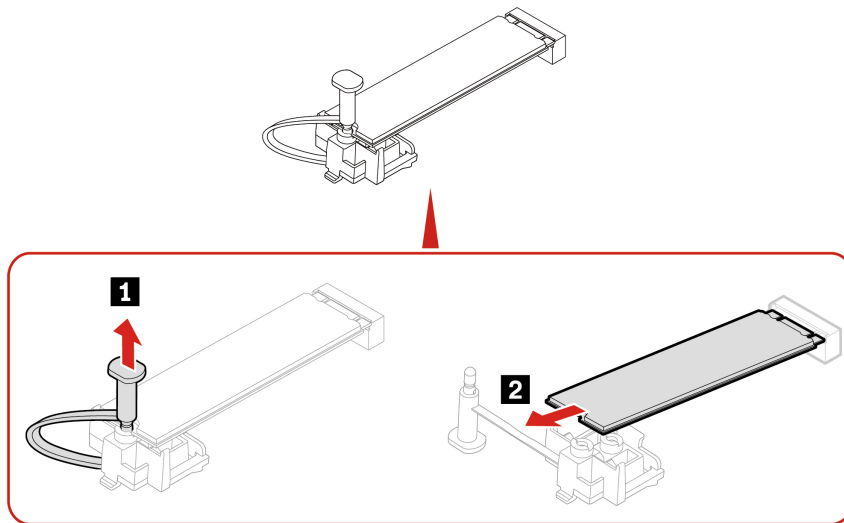

- For computers with the heat sink for the M.2 solid-state drive, do one of the following depending on the computer model:

- Type 1

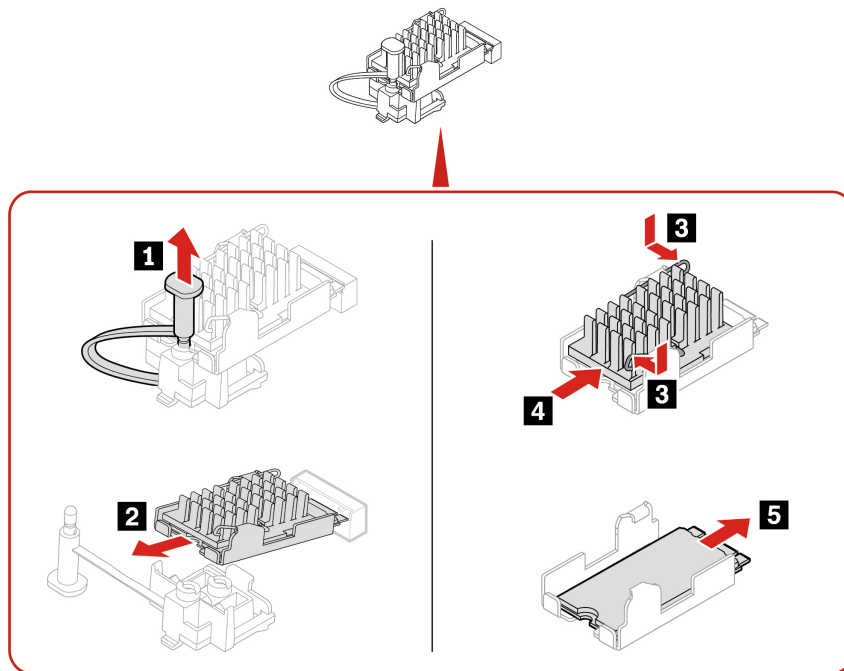

– Type 2

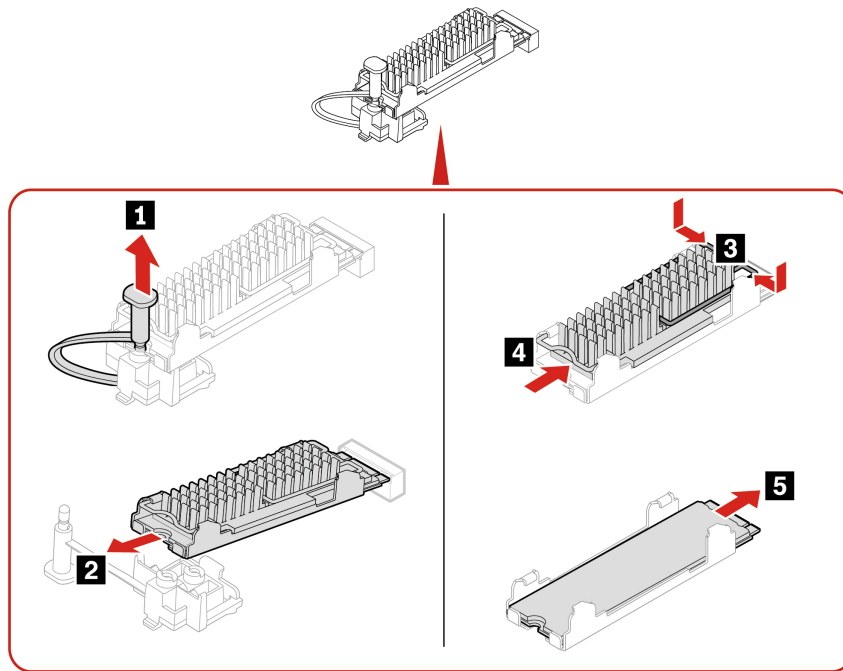

– Type 3

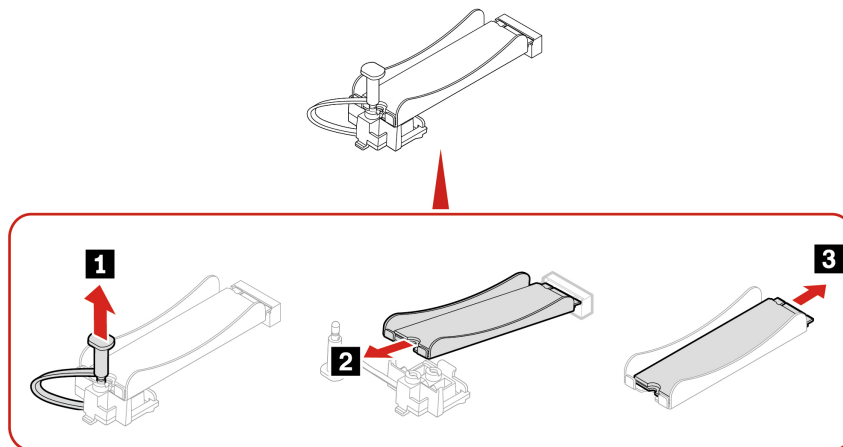

Note: Remove the film that covers the thermal pad (if any) when installing the M.2 solid-state drive and the heat sink.

M.2 solid-state drive bracket

Prerequisite

Before you start, read *Generic Safety and Compliance Notices*, and print the following instructions.

For access, remove these parts in order, if any:

- “Computer cover” on page 19
- “M.2 solid-state drive and heat sink” on page 29

Replacement procedure

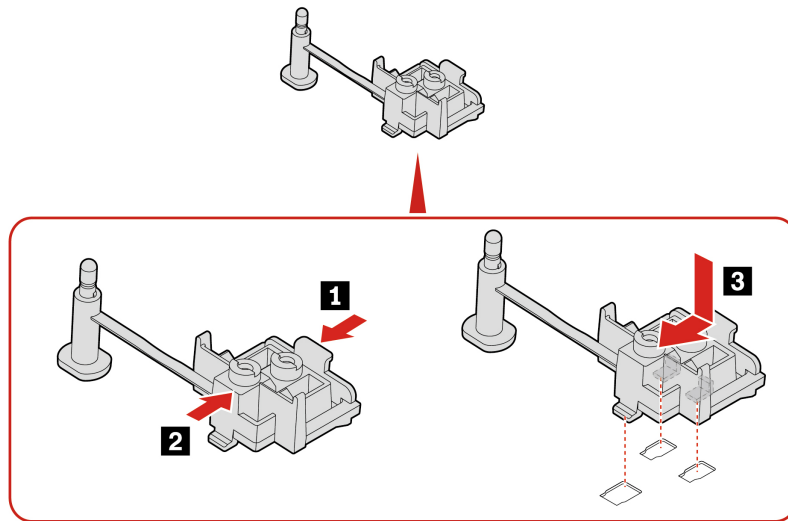

PCI-Express connector cable

Prerequisite

Before you start, read *Generic Safety and Compliance Notices*, and print the following instructions.

For access, do the following:

1. Remove the “Computer cover” on page 19.
2. Disconnect the PCI-Express connector cable from the system board.

Removal steps

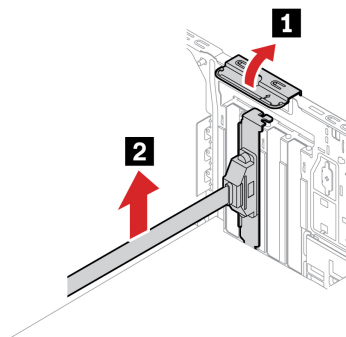

PCI-Express card

Prerequisite

Before you start, read *Generic Safety and Compliance Notices*, and print the following instructions.

For access, remove the “Computer cover” on page 19.

Removal steps

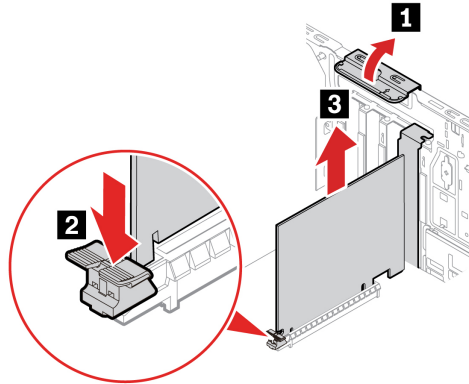

Notes:

- Do not attempt to install any PCI-Express cards other than graphics card to the PCI-Express slot next to the microprocessor.
- Before installing a new PCI-Express card, remove any PCI-Express connector cables that impede the installation. See “PCI-Express connector cable” on page 32.

Graphics card holder

Prerequisite

Before you start, read *Generic Safety and Compliance Notices*, and print the following instructions.

For access, remove the “Computer cover” on page 19.

Replacement procedure

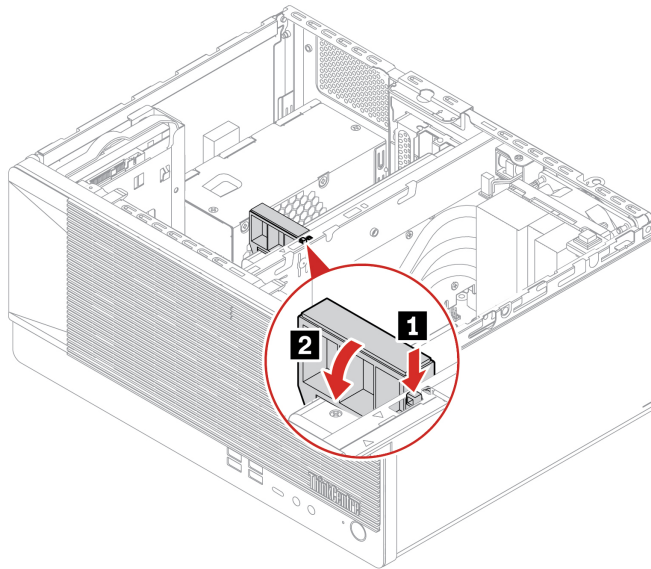

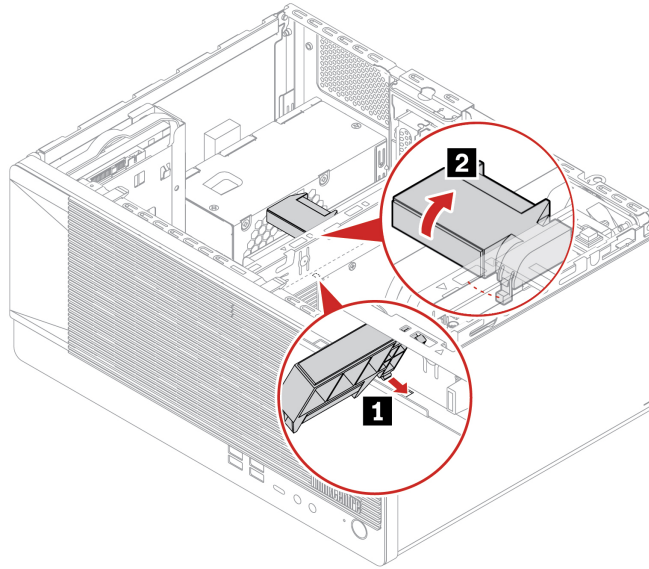

Graphics card

Prerequisite

Before you start, read *Generic Safety and Compliance Notices*, and print the following instructions.

Replacement procedure of the RTX 3050 and RTX 4060 graphics card secured with a graphic card holder

For access, do the following:

1. Remove these parts in order, if any:
 - “Computer cover” on page 19
 - “Optical drive” on page 20
 - “Optical drive cage” on page 26
 - “Graphics card holder” on page 33
2. Disconnect the power cable (if any) from the graphics card.

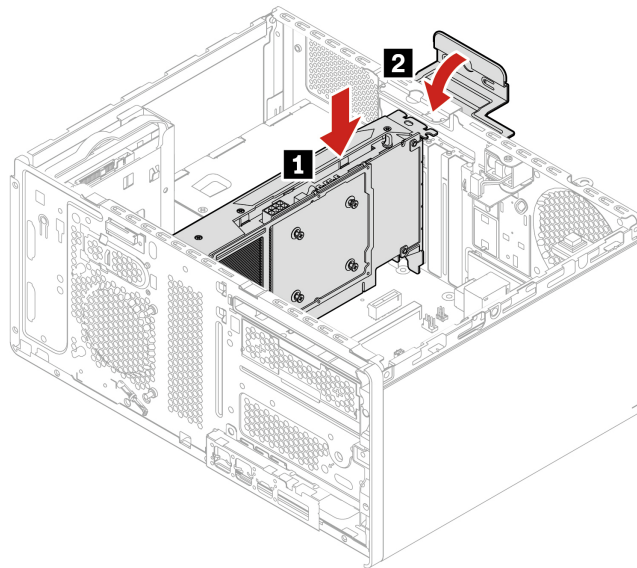
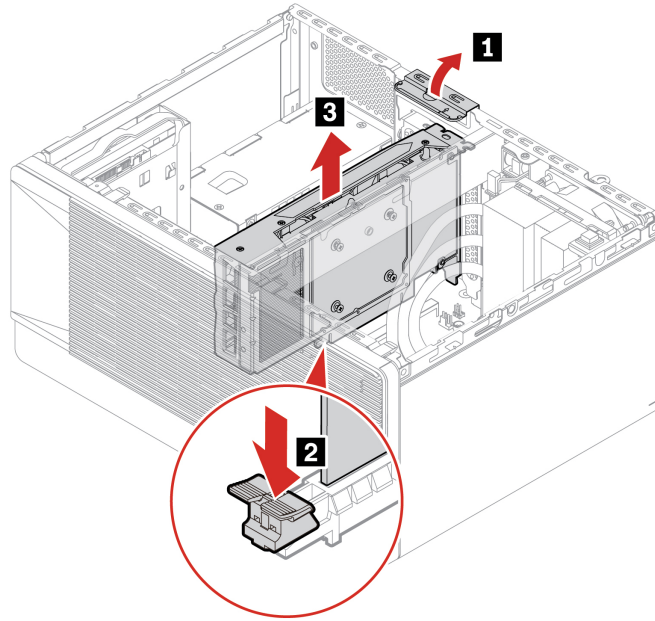

Replacement procedure of the RTX 6400 graphics card

For access, do the following:

1. Remove these parts in order, if any:
 - “Computer cover” on page 19
 - “Optical drive” on page 20
 - “Optical drive cage” on page 26
2. Disconnect the power cable (if any) from the graphics card.

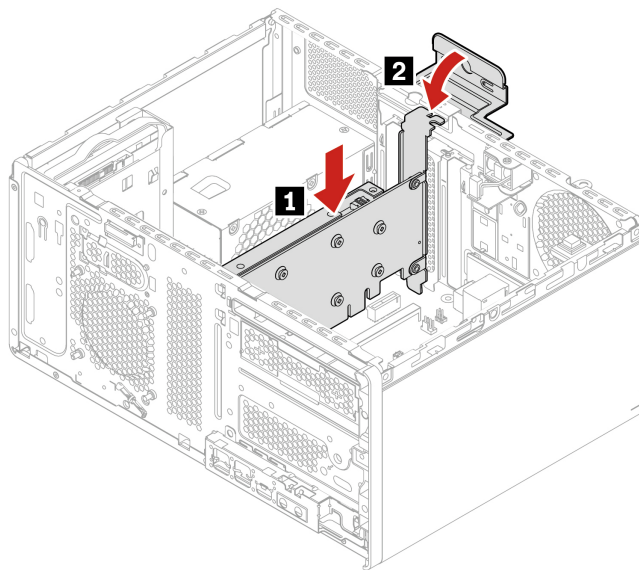
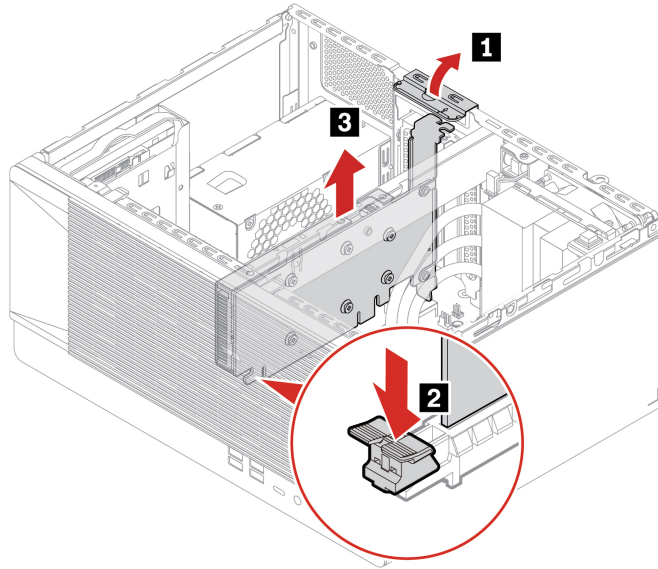

Note: Do not attempt to install any PCI-Express cards other than graphics card to the PCI-Express slot next to the microprocessor.

Memory module

Prerequisite

Before you start, read *Generic Safety and Compliance Notices*, and print the following instructions.

Ensure that you follow the installation order for memory modules shown in the following illustration.

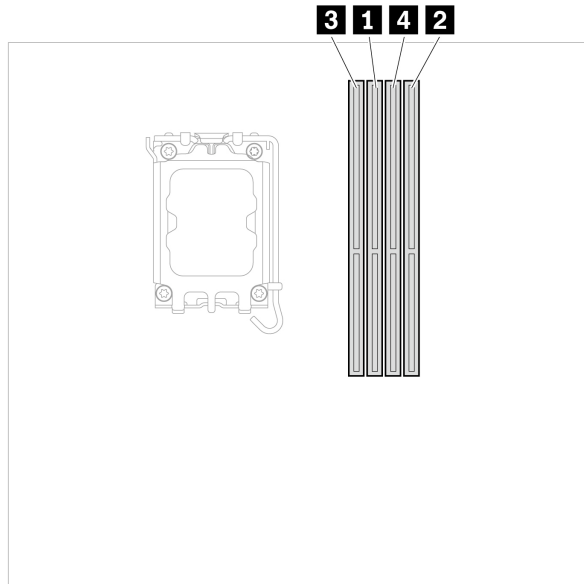

For access, remove these parts in order, if any:

- “Computer cover” on page 19
- “Optical drive” on page 20
- “Front bezel” on page 22
- “Optical drive cage” on page 26

Replacement procedure

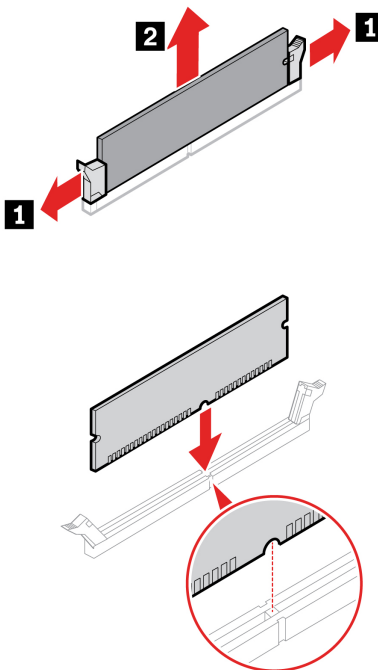

Note: During the installation, ensure that you align the memory module to the slot and press down on both ends until the latches are fully engaged with a click.

3.5-inch primary hard disk drive cage

Prerequisite

Before you start, read *Generic Safety and Compliance Notices*, and print the following instructions.

Attention: The internal storage drive is sensitive. Inappropriate handling might cause damage and permanent loss of data. When handling the internal storage drive, observe the following guidelines:

- Replace the internal storage drive only for upgrade or repair. The internal storage drive is not designed for frequent changes or replacement.
- Before replacing the internal storage drive, make a backup copy of all the data that you want to keep.
- Do not touch the contact edge of the internal storage drive. Otherwise, the internal storage drive might get damaged.
- Do not apply pressure to the internal storage drive.
- Do not make the internal storage drive subject to physical shocks or vibration. Put the internal storage drive on a soft material, such as cloth, to absorb physical shocks.

For access, remove these parts in order, if any:

- “Computer cover” on page 19
- “Optical drive” on page 20
- “Front bezel” on page 22
- “Primary hard disk drives” on page 23

Removal steps

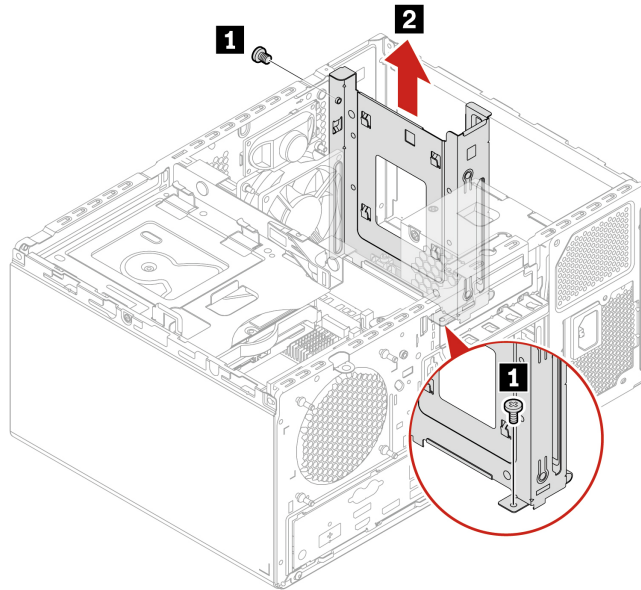

Screw (quantity)	Torque
#6 - 32 x L8, Hex Head (1)	5.0 ± 0.5 lb/in

Power supply assembly

Prerequisite

Before you start, read *Generic Safety and Compliance Notices*, and print the following instructions.

Although there are no moving parts in the computer after the power cord has been disconnected, the following warnings are required for your safety.



Keep fingers and other parts of your body away from hazardous, moving parts. If you suffer an injury, seek medical care immediately. Never remove the cover on a power supply or any part that has the following label attached.



Hazardous voltage, current, and energy levels are present inside any component that has this label attached. There are no serviceable parts inside these components. If you suspect a problem with one of these parts, contact a service technician.

For access, do the following:

1. Remove these parts in order, if any:
 - “Computer cover” on page 19
 - “Optical drive” on page 20
 - “Front bezel” on page 22
 - “Primary hard disk drives” on page 23
 - “3.5-inch primary hard disk drive cage” on page 38
2. Disconnect the power supply assembly cables from the system board.

Removal steps

300-watt/500-watt

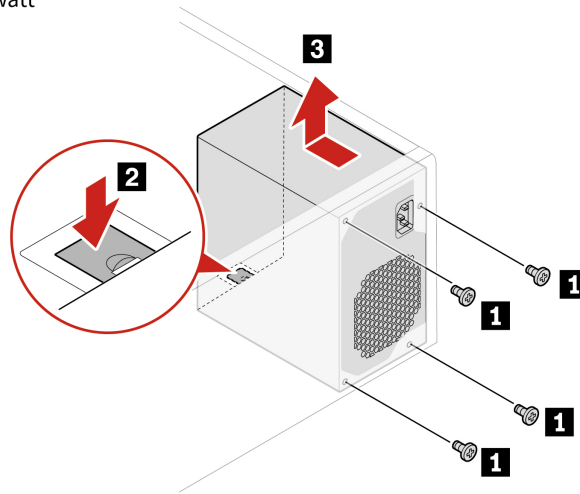

260-watt

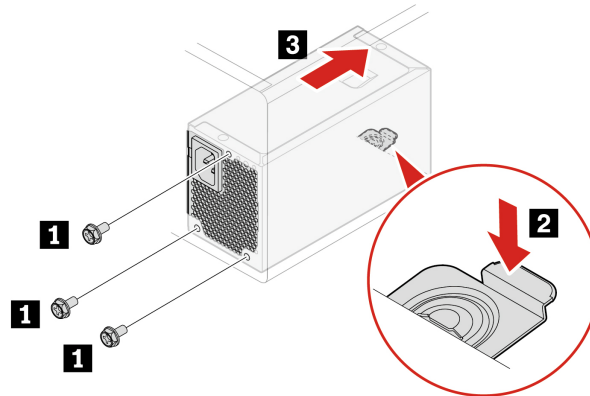

Screw (quantity)	Torque
#6 - 32 x L8, Hex Head (3)	5.0 ± 0.5 lb/in

E-lock

Prerequisite

Before you start, read *Generic Safety and Compliance Notices*, and print the following instructions.

For access, do the following:

1. Remove the “Computer cover” on page 19.
2. Disconnect the E-lock cable from the system board.

Note: To remove the screws, you need a special tool (T15 star wrench).

Removal steps

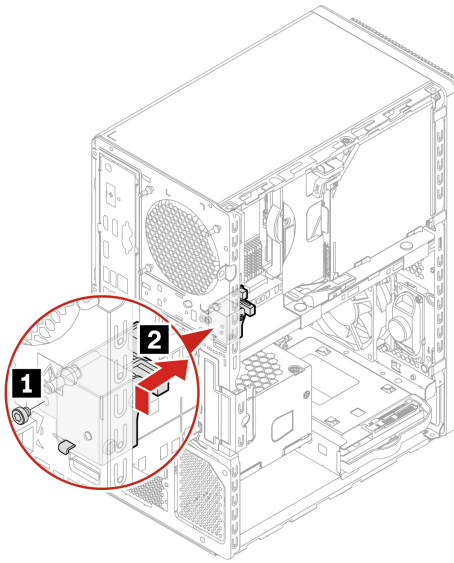

Screw (quantity)	Torque
M3 x 5 mm - T15 (1)	5.0 ± 0.5 lb/in

Chassis beam

Prerequisite

Before you start, read *Generic Safety and Compliance Notices*, and print the following instructions.

For access, remove these FRUs in order if any:

- “Computer cover” on page 19
- “Optical drive” on page 20
- “Front bezel” on page 22
- “Optical drive cage” on page 26
- “Graphics card holder” on page 33
- “Graphics card” on page 34

Replacement procedure

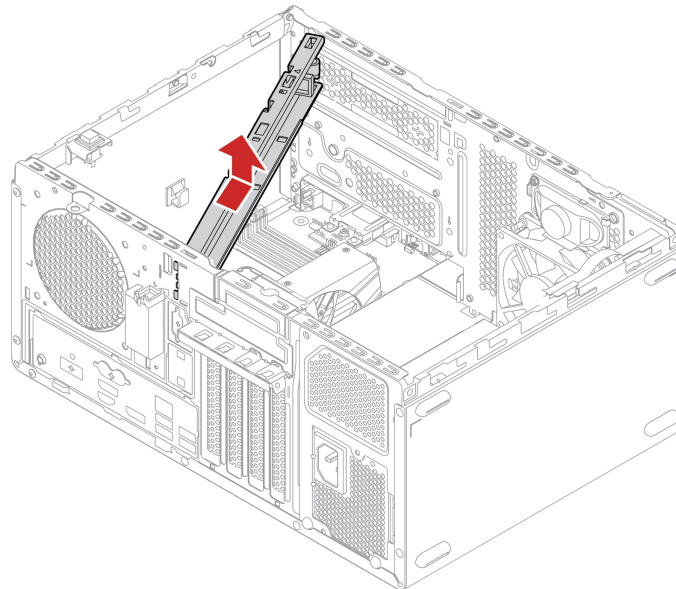
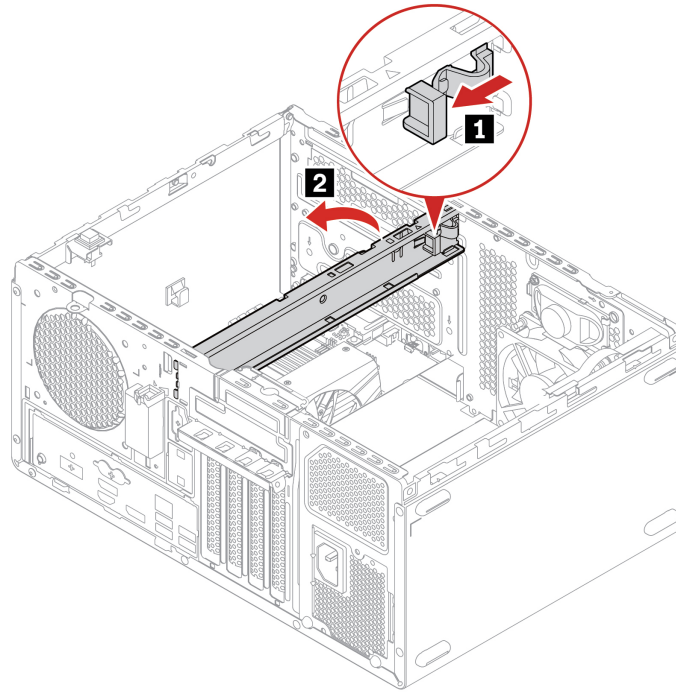

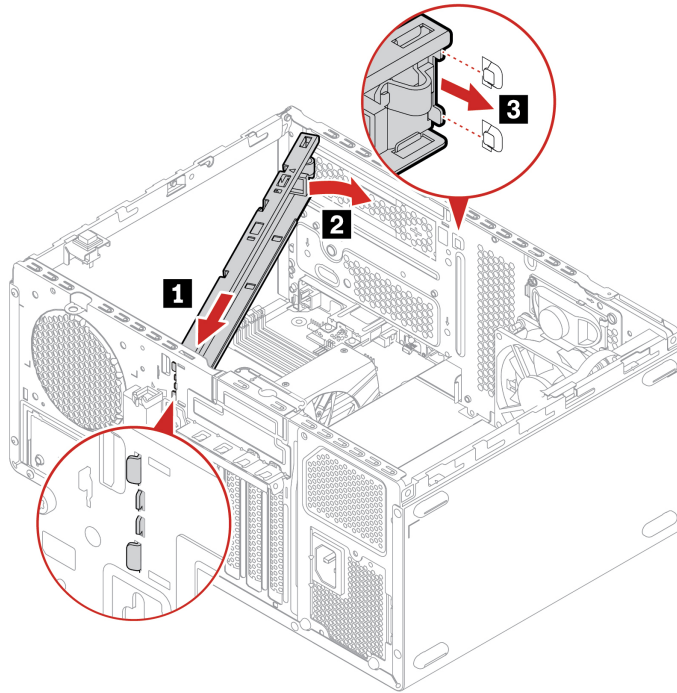

Chapter 5. Help and support

Find your serial number

This topic helps you find computer serial number.

You can find your serial number via:

- **Dashboard** or **Device** in the **Vantage** app
- Serial number and machine type label of your computer (shown as below illustration)

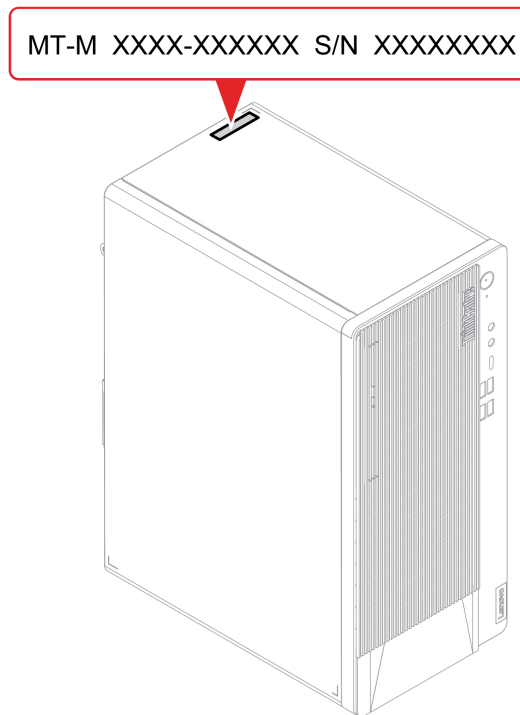

Diagnose and troubleshoot your computer

This section provides introduction to a set of diagnostics and troubleshooting tools at Lenovo Support Web site and the Vantage app. They can help you diagnose common software and hardware issues.

The following table lists these diagnostics tools and the recommended conditions for each tool.

Diagnostics tool	Recommended scenario
Troubleshoot and diagnose at Lenovo Support Web site	You want to have an online troubleshooting or scan of hardware and drivers on your computer.
Hardware scan	<ul style="list-style-type: none">• Your computer is installed with the Vantage app.• You want to perform basic examinations of the hardware components.

Troubleshoot and diagnose at Lenovo Support Web site

Lenovo provides two different diagnosing solutions to help you identify and resolve problems on your computer.

Step 1. Go to <https://www.pcsupport.lenovo.com/> and enter your product name in the search box.

Step 2. Click **Troubleshoot & Diagnose** and select the option that fits your need.

Notes:

- Before launching any automatic diagnosing process, a pop-up window will be prompted to install Lenovo Service Bridge. Lenovo Service Bridge helps to connect your computer with Lenovo diagnosing tools.
- Lenovo Support Web site makes periodic updates of the sections to keep improving your experience with your computer. The Web site interface and descriptions of sections might be different from that on your actual interface.
- If you are unaware of what problem your computer goes with, it is recommended that you select **Easy** and follow on-screen instructions to get your firmware updated and obtain the hardware status.
- If you have identified the problem on your computer, you can select **Custom** and follow on-screen instructions to resolve the problem.

If solutions can not resolve problems on your computer, you can follow on-screen instructions to submit an e-ticket or contact Lenovo for professional assistance.

Hardware scan

Hardware scan is an effective hardware testing tool to help you identify existing hardware issues.

To run the Hardware scan:

Step 1. Type **Vantage** in the Windows search box and then press Enter.

Step 2. Click **Hardware scan** or **Support → Hardware scan**.

Step 3. Select **QUICK SCAN** or **CUSTOMIZE** and then follow the on-screen instructions to run the hardware scan.

Notes:

- The Quick Scan tool contains a pre-selected suite of tests that performs basic examinations of the hardware components found in the system. The Customize tool enables you to select one or several hardware components to perform the examinations.
 - Before selecting **QUICK SCAN**, click **Refresh Modules** to ensure that the list of hardware components is the components currently available for the computer.
- Step 4. If any hardware failure is detected, the result varies depending on the warranty status and varies by country or region. Follow the on-screen instructions to resolve the issue.

Recover your Windows operating system

When you encounter some unexpected issues with your operating system, you can choose to recover your operating system by yourself or call Lenovo Customer Support Center.

Note: Microsoft constantly makes updates to the Windows operating system. Before installing a particular Windows version, check the compatibility list for the Windows version. For details, go to <https://support.lenovo.com/us/en/solutions/ht512575>.

To recover your operating system to...	See.
Factory defaults	Refer to the instructions in https://support.lenovo.com/HowToCreateLenovoRecovery
A previous system point	Refer to the instructions in Popular Topics: https://support.lenovo.com/solutions/ht118590

Call Lenovo

If you have tried to correct the problem yourself and still need help, you can call Lenovo Customer Support Center.

Before you contact Lenovo

Prepare the needed information before you contact Lenovo.

1. Record the problem symptoms and details:
 - What is the problem? Is it continuous or intermittent?
 - Any error message or error code?
 - What operating system are you using? Which version?
 - Which software applications were running at the time of the problem?
 - Can the problem be reproduced? If so, how?
2. Record the system information:
 - Product name
 - Machine type and serial number.

Self-help resources

Use the following self-help resources to learn more about the computer and troubleshoot problems.

Resources	How to access?
Lenovo Support Web Site	https://pcsupport.lenovo.com
Tips	https://www.lenovo.com/tips
Lenovo Community	https://forums.lenovo.com
Accessibility information	https://www.lenovo.com/accessibility
Windows help information	<ul style="list-style-type: none"> • Open the Start menu and click Get Help or Tips. • Use Windows Search or the Cortana® personal assistant. • Microsoft support Web site: https://support.microsoft.com

Purchase accessories or additional services

This topic provides instructions on how to purchase accessories or additional services.

Accessories

Lenovo has a number of hardware accessories and upgrades to help expand the functionalities of your computer. Accessories include memory modules, storage devices, network cards, power adapters, keyboards, mice, and so on.

To shop at Lenovo, go to <https://www.lenovo.com/accessories>.

Additional services

During and after the warranty period, you can purchase additional services from Lenovo at <https://pcsupport.lenovo.com/warrantyupgrade>.

Service availability and service names might vary by country or region.

Appendix A. Notices and trademarks

Notices

Lenovo may not offer the products, services, or features discussed in this document in all countries. Consult your local Lenovo representative for information on the products and services currently available in your area. Any reference to a Lenovo product, program, or service is not intended to state or imply that only that Lenovo product, program, or service may be used. Any functionally equivalent product, program, or service that does not infringe any Lenovo intellectual property right may be used instead. However, it is the user's responsibility to evaluate and verify the operation of any other product, program, or service.

Lenovo may have patents or pending patent programs covering subject matter described in this document. The furnishing of this document does not give you any license to these patents. You can send license inquiries, in writing, to:

*Lenovo (United States), Inc.
8001 Development Drive
Morrisville, NC 27560
U.S.A.
Attention: Lenovo Director of Licensing*

LENOVO PROVIDES THIS PUBLICATION "AS IS" WITHOUT WARRANTY OF ANY KIND, EITHER EXPRESS OR IMPLIED, INCLUDING, BUT NOT LIMITED TO, THE IMPLIED WARRANTIES OF NON-INFRINGEMENT, MERCHANTABILITY OR FITNESS FOR A PARTICULAR PURPOSE. Some jurisdictions do not allow disclaimer of express or implied warranties in certain transactions, therefore, this statement may not apply to you.

Changes are made periodically to the information herein; these changes will be incorporated in new editions of the publication. To provide better service, Lenovo reserves the right to improve and/or modify the products and software programs described in the manuals included with your computer, and the content of the manual, at any time without additional notice.

The software interface and function and hardware configuration described in the manuals included with your computer might not match exactly the actual configuration of the computer that you purchase. For the configuration of the product, refer to the related contract (if any) or product packing list, or consult the distributor for the product sales. Lenovo may use or distribute any of the information you supply in any way it believes appropriate without incurring any obligation to you.

The products described in this document are not intended for use in implantation or other life support applications where malfunction may result in injury or death to persons. The information contained in this document does not affect or change Lenovo product specifications or warranties. Nothing in this document shall operate as an express or implied license or indemnity under the intellectual property rights of Lenovo or third parties. All information contained in this document was obtained in specific environments and is presented as an illustration. The result obtained in other operating environments may vary.

Lenovo may use or distribute any of the information you supply in any way it believes appropriate without incurring any obligation to you.

Any references in this publication to non-Lenovo Web sites are provided for convenience only and do not in any manner serve as an endorsement of those Web sites. The materials at those Web sites are not part of the materials for this Lenovo product, and use of those Web sites is at your own risk.

Any performance data contained herein was determined in a controlled environment. Therefore, the result obtained in other operating environments may vary significantly. Some measurements may have been made on development-level systems and there is no guarantee that these measurements will be the same on generally available systems. Furthermore, some measurements may have been estimated through extrapolation. Actual results may vary. Users of this document should verify the applicable data for their specific environment.

This document is copyrighted by Lenovo and is not covered by any open source license, including any Linux® agreement(s) which may accompany software included with this product. Lenovo may update this document at any time without notice.

For the latest information or any questions or comments, contact or visit the Lenovo Web site:

<https://pcsupport.lenovo.com>

Trademarks

Lenovo, Lenovo logo, ThinkCentre, and ThinkCentre logo are trademarks of Lenovo. Intel, Intel SpeedStep, Optane, and Thunderbolt are trademarks of Intel Corporation or its subsidiaries in the U.S. and/or other countries. Microsoft, Windows, Direct3D, BitLocker, and Cortana are trademarks of the Microsoft group of companies. Mini DisplayPort (mDP), DisplayPort, and VESA are trademarks of the Video Electronics Standards Association. The terms HDMI and HDMI High-Definition Multimedia Interface are trademarks or registered trademarks of HDMI Licensing LLC in the United States and other countries. Wi-Fi, Wi-Fi Alliance, WiGig, and Miracast are registered trademarks of Wi-Fi Alliance. USB-C is a registered trademark of USB Implementers Forum. All other trademarks are the property of their respective owners.

Lenovo