

JH693A-AO

HP Compatible 10GBase-CU SFP+ Direct Attached Cable (Twinax, 0.5m, Passive)

Features

- Support for multi-gigabit data rates up to 10 Gb/s
- Data rates backward compatible to 1 Gb/s
- Hot-Pluggable SFP 20PIN footprint
- Improved Pluggable Form Factor (IPF) compliant for enhanced EMI/EMC performance
- Compatible to SFP+ MSA
- Compatible to SFF-8431, SFF-8432
- Temperature Range: 0~70°C
- RoHS Compliant

Application

- High Capacity I/O in Storage Area Networks, Network Attached Storage, and Storage Servers
- Switched fabric I/O such as ultra-high bandwidth switches and routers
- Data center cabling infrastructure
- High density connections between networking equipment

Product Description

This is an HP® JH693A compatible 10GBase-CU SFP+ to SFP+ direct attach cable that operates over passive copper with a maximum reach of 0.5m (1.6ft). It has been programmed, uniquely serialized, and data-traffic and application tested to ensure it is 100% compliant and functional. This direct attach cable is TAA (Trade Agreements Act) compliant, and is built to comply with MSA (Multi-Source Agreement) standards. We stand behind the quality of our products and proudly offer a limited lifetime warranty.

AddOn's SFP+ direct attach cables are RoHS compliant and lead free.

TAA refers to the Trade Agreements Act (19 U.S.C. & 2501-2581), which is intended to foster fair and open international trade. TAA requires that the U.S. Government may acquire only "U.S. – made or designated country end products."



Recommended Operating conditions

Parameter	Symbol	Min	Typ.	Max.	Unit
Storage Temperature		-40		85	°C
Operating Case Temperature	Tc	0		70	°C

Systems

Parameter	Media
10 Gb/s line speed, full duplex Bit error rate: better than 10E-12	Hot-pluggable, industry-standard Small Form-Factor Pluggable (SFP+) copper cable, available up to 7m.

Pin Descriptions

Pin	Logic	Symbol	Name/Description	Notes
1		VeeT	Transmitter Ground	
2	LV-TTL-O	TX_Fault	N/A	1
3	LV-TTL-I	TX_DIS	Transmitter Disable	2
4	LV-TTL-I/O	SDA	Tow Wire Serial Data	
5	LV-TTL-I	SCL	Tow Wire Serial Clock	
6		MOD_DEF0	Module present, connect to VeeT	
7	LV-TTL-I	RS0	N/A	1
8	LV-TTL-O	LOS	LOS of Signal	2
9	LV-TTL-I	RS1	N/A	1
10		VeeR	Receiver Ground	
11		VeeR	Receiver Ground	
12	CML-O	RD-	Receiver Data Inverted	
13	CML-O	RD+	Receiver Data Non-inverted	
14		VeeR	Receiver Ground	
15		VccR	Receiver Supply 3.3V	
16		VccT	Transmitter Supply 3.3V	
17		VeeT	Transmitter Ground	
18	CML-I	TD+	Transmitter Data Non-Inverted	
19	CML_I	TD-	Transmitter Data Inverted	
20		VeeT	Transmitter Ground	

Notes:

1. Signals not supported in SFP+ Copper pulled-down to VeeT with 30K ohms resistor

2. Passive Cable assemblies do not support LOS and TX_DIS

Mechanical Specification

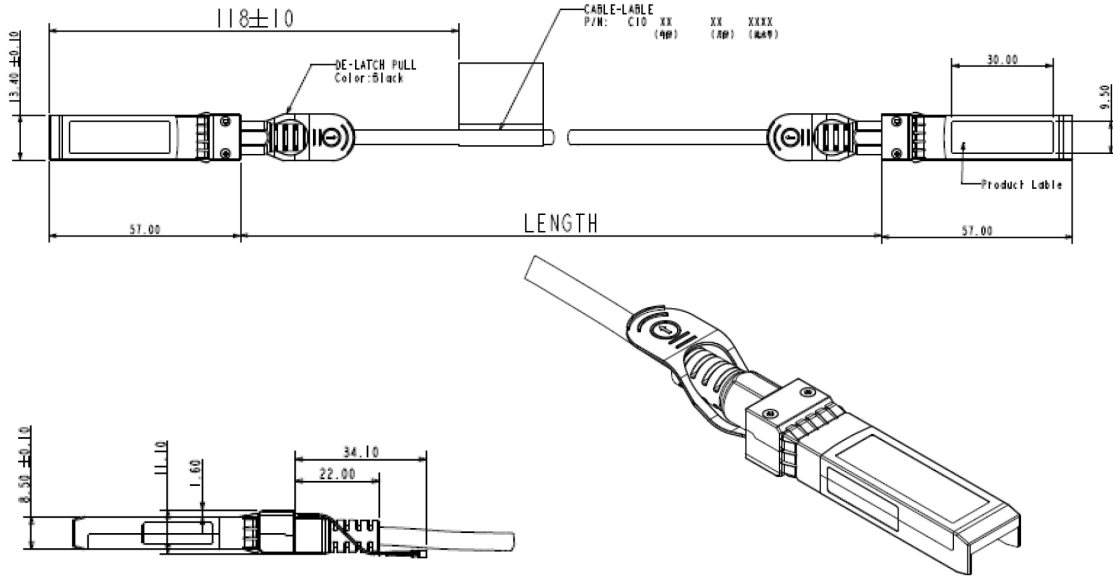

Contact Information

Founded in 1999, AddOn Networks is North America's leading provider of transceivers and high speed cabling. With a reputation for high quality products as well as an extensive custom design portfolio, AddOn has the connectivity solution regardless of the requirement.

At AddOn, 100% of the products we ship every day are tested in the specific application for which they are intended—never batch or spec tested only. We run bandwidth, distance and IOS network tests. We have documented an impressive 0.03% failure rate over the last 10 years. To continue this rate of success we invest millions annually in our own on-site testing lab.

Corporate office:
AddOn Networks
15775 Gateway Circle
Tustin, CA 92780

Tel: 877-292-1701
Fax: 949-266-9273
Email: sales@addonnetworks.com
Email: support@addonnetworks.com
Web: <http://www.addonnetworks.com>