

650329 32"-70" Motorized TV Ceiling Mount Bracket

Product Images

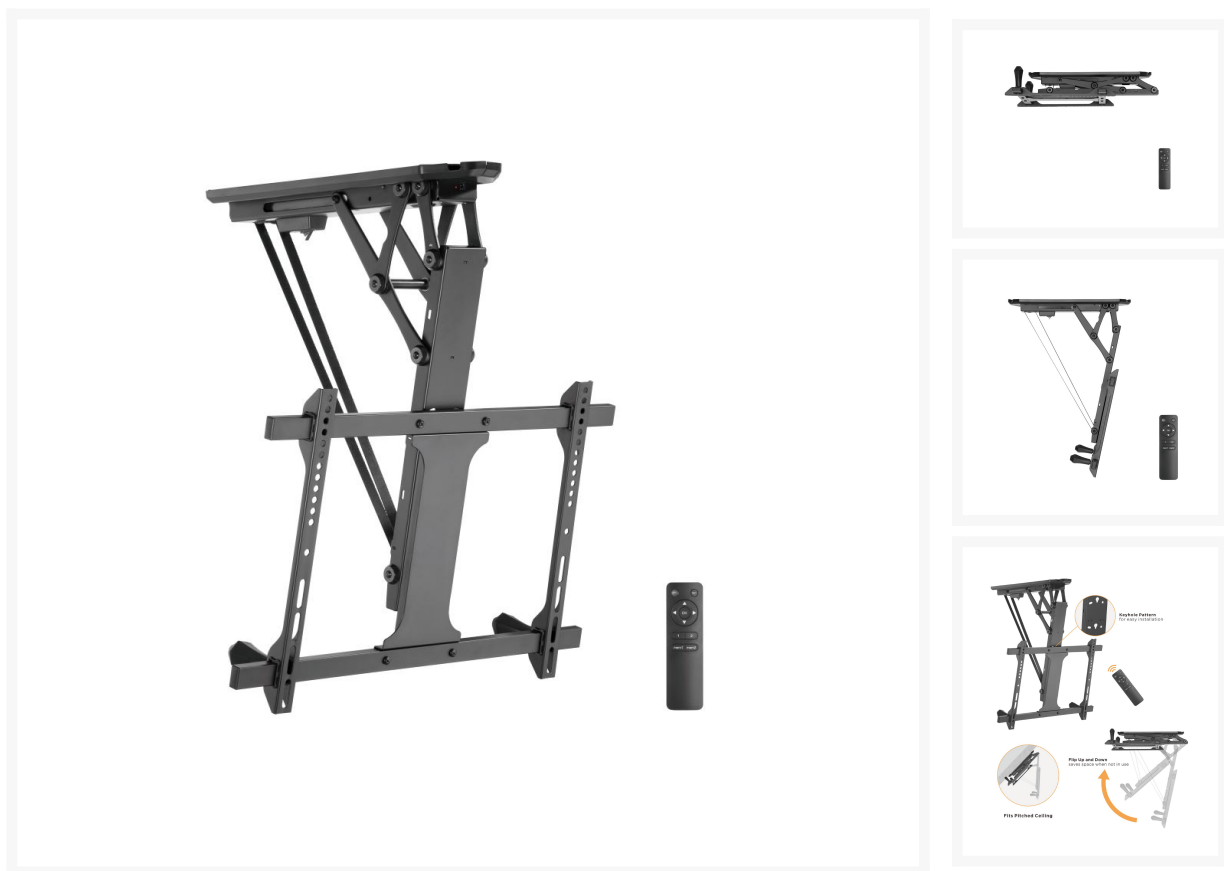

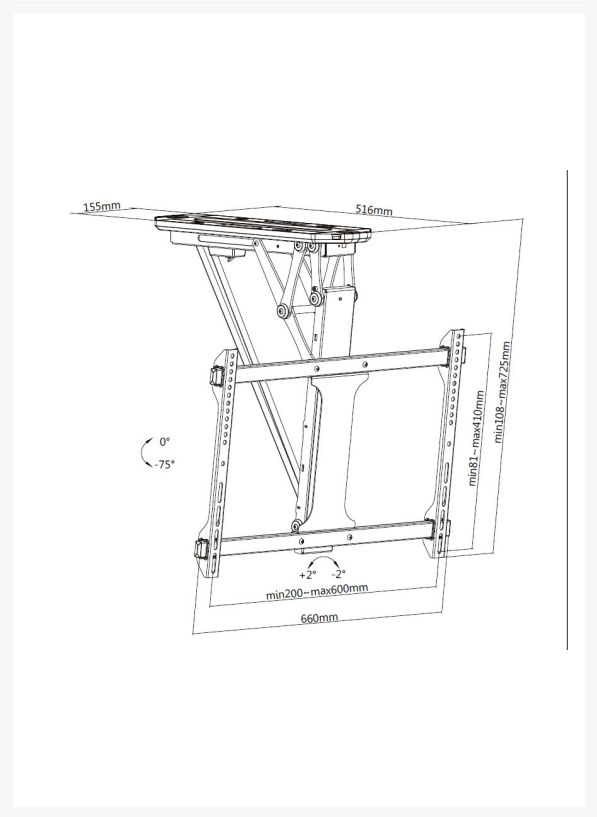



Short Description

- Max. Load Capacity: 35Kg
- Max. VESA: 600x400
- VESA standards compliant
- Flip down design: allows for easy storage, save space
- Level adjustment ensures perfect positioning
- Built-in Cable management
- Remote Control Included: for easy movements

Description

The equip 650329 motorized TV Ceiling mount bracket is the perfect item to saves spce for the room with low ceiling (flat and pitchd), retracts and keeps flush to the top . Combined with the balanced mechanism to stop TV shaking on the ceiling.

The high-quality motor provides an automatic lift function with just the press of a button. The convenient RF remote allows operation through walls and at distance from the TV

Additional Information

Harmonized System (HS) code	852990
Customs product code (TARIC)	8529909700
Approval and Compliance	CE, RoHS
Package Contents	650329 Manual screws kits
Color	Black
EAN	4015867227152
Model Number	650329
Mounting hole pattern	Standard VESA
Anti-theft	No
Cable management	Yes
Bracket type	Tiltable
Installation	Ceiling Mounted
Distance to wall (Profile)	108mm
Load Capacity (kg)	35kg
Material	Plastic, Stainless Steel
Screens support quantity	1
Support Curved TV (Monitors)	Yes
Tilt range	0~-75°
VESA compatibility	200x200,300x200,200x400, 400x200,300x300,400x300, 400x400,600x400
Mount	Ceiling mount
Dimensions (W x D x H)	546 x 110 x 664 mm
Product weight (kg)	9

