

SAMSUNG

Galaxy Watch FE



User guide

Contents

Getting started

Device Layout: [Galaxy Watch FE](#)

Set up your device: [Charge the battery](#) | [Maintaining water and dust resistance](#) | [Wireless power sharing](#) | [Wear the Watch](#)

Start using your device: [Turn on your device](#) | [Activation](#) | [Galaxy Wearable app](#) | [Lock or unlock your device](#) | [Customize buttons](#) | [Navigation](#) | [Change the watch face](#) | [Quick panel](#) | [Tiles](#) | [Notifications](#) | [Sleep mode](#) | [Do not disturb](#) | [Water lock mode](#) | [Theater mode](#) | [Enter text](#)

Apps

Tools: [Alarm](#) | [Bixby](#) | [Calculator](#) | [Calendar](#) | [Compass](#) | [Contacts](#) | [Find My Phone](#) | [Reminder](#) | [Samsung Global Goals](#) | [SmartThings](#) | [Samsung Pay](#) | [Stopwatch](#) | [Timer](#) | [Voice Recorder](#) | [Weather](#) | [World clock](#)

Media: [Buds controller](#) | [Camera controller](#) | [Gallery](#) | [Media controller](#) | [Music](#) | [Messages](#) | [Phone](#)

Health: [Samsung Health](#) | [Samsung Health Monitor](#)

Google: [Maps](#) | [Messages](#) | [Play store](#)

Microsoft: [Outlook](#)

Settings

Connections: [Bluetooth](#) | [Wi-Fi](#) | [NFC and contactless payments](#) | [Disconnection alerts](#) | [Airplane mode](#) | [Mobile networks](#) | [Data usage](#)

Notifications: [Notification settings](#) | [Advanced notification settings](#)

Sounds and vibration: [Sound mode](#) | [Vibration](#) | [Call vibration](#) | [Notification vibration](#) | [System vibration](#) | [Volume](#) | [Ringtone](#) | [Notification sound](#) | [System sounds](#)

Display: [Adjust screen brightness](#) | [Always on Display](#) | [Screen wake-up](#) | [Set the screen timeout](#) | [Show last app](#) | [Font](#) | [Touch sensitivity](#) | [Show charging info](#)

Security and privacy: [Set a screen lock](#) | [Permission manager](#) | [Wrist detection](#) | [Location](#) | [Safety and emergency](#)

Accounts: [Samsung account](#) | [Google account](#) | [Google settings](#)

Device maintenance: [Battery](#) | [Storage](#) | [Memory](#) | [Watch only mode](#) | [Touch bezel](#) | [Text to speech](#) | [Date and time](#) | [Orientation](#) | [Transfer watch to new phone](#) | [Reset the Watch](#)

Accessibility: [TalkBack](#) | [Vision enhancements](#) | [Hearing enhancements](#) | [Interaction and dexterity](#) | [Advanced settings](#) | [Installed apps](#)

Other: [Software update](#) | [Tips and tutorials](#) | [About watch](#)

Learn More

[Videos](#) | [Samsung Care](#) | [Talk to an agent](#)

Legal information

[Restricting children's access to your mobile device](#)

Getting started

Galaxy Watch FE

Set up your device

Start using your device



Galaxy Watch FE



Set up your device

Learn more about your device hardware, assembling and charging, and how to get started using your new device.

[Charge the battery](#) | [Maintaining water and dust resistance](#) | [Wireless power sharing](#) | [Wear the Watch](#)

Charge the battery

Your device is powered by a rechargeable battery.

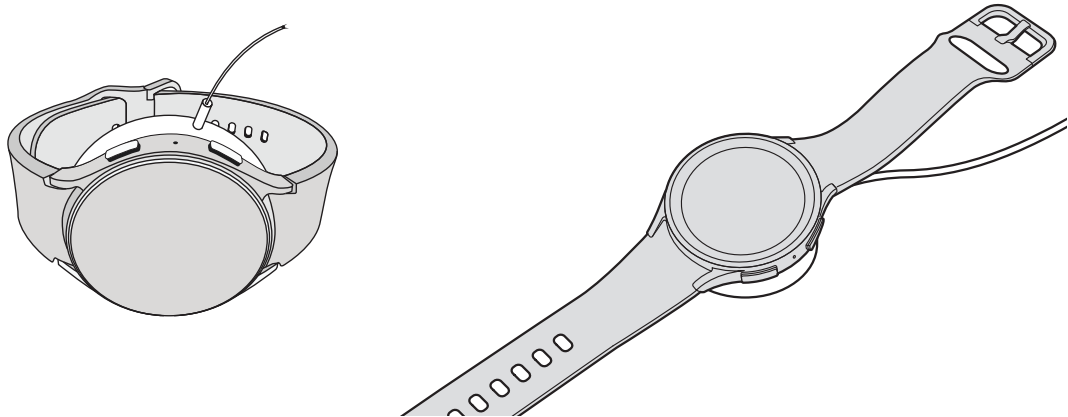

1. Connect the wireless charger to a charging port.
2. Place the watch onto the wireless charger, aligning the center of your watch with the center of the wireless charger.
3. After fully charging, disconnect the watch from the wireless charger.

 **CAUTION** The charging head for plugging the USB cable into a wall outlet is not included. Use only Samsung charging devices rated with an output voltage of 5v and an output current of over 150mA (sold separately). Samsung accessories are designed for your device to maximize battery life. Using other accessories may void your warranty and may cause damage.

 **NOTE** Prevent the USB charger port and the small end of the charger cable from coming into contact with conductive materials, such as liquids, dust, metal powders, and pencil leads.

While charging, the device and the charger may become hot. This does not affect the device's lifespan or performance and is in the device's normal range of operation.

Remove the device from the charger and wait for the device to cool down.

Learn more: <https://www.samsung.com/us/support/answer/ANS00076952>

 **NOTE** Do not disassemble, modify, or repair your device. Placing objects, such as magnetic stripe cards, including credit cards, phone cards, passbooks, and boarding passes, next to the device or charger may cause damage from the charger or device's magnetic field.

Maintaining water and dust resistance

The device is not impervious to dust and water damage in any situation. It is important that all compartments are closed tightly. Learn more: **Mobile Terms and Conditions (samsung.com)**

Follow these tips carefully to prevent damage to the device and maintain dust and water resistance performance:

 **CAUTION** To avoid electric shock and damage to your device, do not charge device while it is wet or in an area where it could get wet. Do not handle device, charger or cords with wet hands while charging.

- Water resistant based on IP68 rating, which tests submersion in fresh water deeper than 1.5 meters or keep it submerged for more than 30 minutes. If your device is exposed to fresh water, shake it to remove any excess water and dry the device thoroughly with a clean, soft cloth.
- If your device is exposed to liquids other than fresh water (such as saltwater), rinse your device with fresh water and dry it with a clean, soft cloth and shake it to remove any excess water.

- Any device which uses accessible compartments or ports that can be opened should have these sealed or closed tightly to prevent liquid from entering the system.
- If the device has been immersed in water or the microphone or speaker is wet, sound may not be heard clearly during a call while the device is immersed or the microphone or speaker is wet.
- Do not expose the device to water at high pressure.
- If the device is dropped or receives an impact that causes physical damage to the device, the water and dust resistant features of the device may be affected. If you suspect your device has been damaged because of a fall or impact, take it to a Samsung-authorized service center for inspection.

Wireless power sharing

Wirelessly charge your device using a supported Samsung mobile device. Some features are not available while sharing power.



1. From your mobile device, enable the Wireless power sharing feature.
2. With the mobile device face down, place the compatible device on the back of the mobile device to charge. A notification sound or vibration occurs when charging begins.



NOTE Wireless power sharing works with most Qi-Certified devices. Requires minimum 30% battery to share. Speed and power efficiency of charge varies by device. May not work with some accessories, covers, or other manufacturer's devices. If you have trouble connecting or charging is slow, remove any cover from each device.

For best results when using Wireless power sharing, please note:

- Remove any accessories or cover before using the feature. Depending on the type of accessory or cover, Wireless power sharing may not work properly.
- The location of the wireless charging coil may vary by device, so you may need to adjust the placement to make a connection. When charging starts, a notification or vibration will occur, so the notification will help you know you've made a connection. During charging, do not move or use either device.
- Call reception or data services may be affected, depending on your network environment.
- Charging speed or efficiency can vary depending on device condition or surrounding environment.
- Do not use headphones.

Wear the Watch

Wrap the watch firmly around your lower arm just above your wrist leaving a finger's worth of space as shown below. Do not fasten the watch too tightly.

 **WARNING** Wear the device correctly. If you feel discomfort while using the device, stop using it. If your device becomes hot, please remove it until it cools.



1. Open the buckle and place the strap around your wrist.
2. Fit the strap to your wrist, insert the pin into an adjustment hole, and then secure the buckle to close it.

Strap tips and precautions

- Some people may experience discomfort when wearing the watch for prolonged periods.
- If you have sensitive skin or fasten the watch too tightly, you may feel some discomfort.
- Do not expose the straps to very wet conditions. Wet straps can cause skin irritations. Dry the straps first. If you experience skin irritation when wearing the watch, stop wearing it and consult a physician.

Replace the strap

Detach the strap from the watch to replace it with a new one.

To remove the strap:

- Press the **Band release** button and pull the end of the band away from the watch.

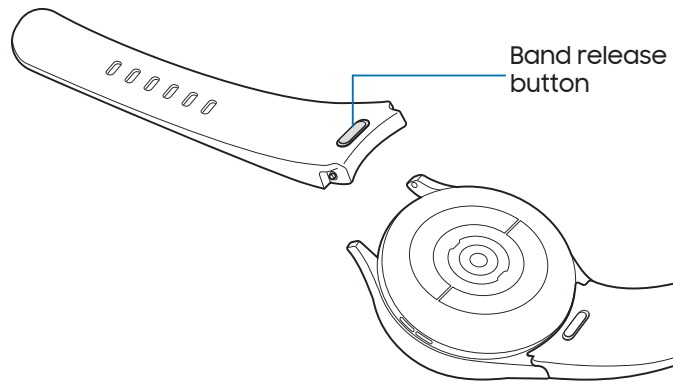

To replace the strap:

- Press the **Band release** button and press the end of the band firmly into the lug.

Start using your device

[Turn on your device](#) | [Activation](#) | [Galaxy Wearable app](#) | [Lock or unlock your device](#) | [Customize buttons](#) | [Navigation](#) | [Change the watch face](#) | [Quick panel](#) | [Tiles](#) | [Notifications](#) | [Sleep mode](#) | [Do not disturb](#) | [Water lock mode](#) | [Theater mode](#) | [Enter text](#)

Turn on your device

Use the Home button to turn your watch on or off.

- Press and hold the **Home** button.
 - To turn the watch off, swipe down from the top of the watch screen to open the Quick panel, and tap  >  **Turn off**.





TIP To restart the watch, press and hold the **Home** and **Back** buttons for more than seven seconds.

Activation

The Galaxy Watch FE is 4G LTE-enabled. Get texts, alerts, make and receive calls, even when you leave your smartphone behind.

To manage your watch's mobile plan:

- From the smartphone, tap  **Galaxy wearable**, tap  **Watch settings** >  **Mobile plans**. Consult your service provider for more information about activation.

Galaxy Wearable app

To connect your watch to a smartphone, install the Galaxy Wearable app on the smartphone. You can download the app from the Galaxy Store or the Google Play™ store.

Galaxy Wearable is compatible with select devices using Android 10.0 and later with at least 1.5 GB RAM. Supported devices may vary by carrier and device. Some features may not be available. For best results, connect with compatible Samsung Galaxy devices.

Learn more: samsung.com/us/support/owners/app/galaxy-wearable-watch

Connect the watch to a smartphone

Turn on the watch before connecting to your smartphone.

1. From the smartphone, tap  **Galaxy Wearable**. If necessary, update the app to the latest version.
2. Tap **Start** and select your device.
3. When the Bluetooth® pairing request window is displayed, confirm the passkeys displayed on your watch and smartphone match, and then tap **Confirm**.
4. Follow the prompts to complete the connection.
5. On the watch, you can tap **Start** to begin a tutorial to learn the basic controls, or **Skip** to start using your new watch.

Back up data

The watch can only be connected to one smartphone at a time. Make sure you back up any important data stored on your watch.

1. From the smartphone, tap  **Galaxy Wearable**, tap  **Watch settings**.
2. Tap  **Accounts and backup** to customize your backup settings.

Remote connection

Set the watch to remotely connect to the smartphone when a Bluetooth connection between the devices is not available. With this connection, you can still receive notifications from your smartphone.

1. From the smartphone, tap  **Galaxy Wearable**, tap  **Watch settings**.
2. Tap  **Advanced features** > **Remote connection** to enable the feature.

Disconnect

To disconnect the watch from your smartphone:

1. From the smartphone, tap  **Galaxy Wearable**, tap  **Menu**.
2. Tap  **Disconnect** by the name of your watch.

Lock or unlock your device

By default your screen is not locked. You can use the screen lock feature to secure your device.

When enabled, your watch locks when you remove it from your wrist or when the screen times out while you are wearing it.

Learn more: [Set a screen lock](#)

To lock the watch:

- Cover the screen with your palm.

To unlock the watch:



- Press any button to turn on the watch screen.
 - If you have a lock screen enabled, press any button to enter your pattern or pin and unlock the watch.

Customize buttons

You can customize the shortcuts assigned to the Home and Back buttons.



Home button

Configure shortcuts for the Home button.

1. From  **Settings**, tap  **Advanced features** > **Customize buttons**.
2. Tap an option under **Home button** to choose a shortcut.
 - **Double press**: Choose which feature is launched when the Home button is pressed twice. By default this option is set to open Samsung Pay.
 - **Press and hold**: Choose which feature is launched when you press and hold the Home button. By default this option is set to wake Bixby.

Back button

Configure shortcuts for the Back button.

1. From  **Settings**, tap  **Advanced features** > **Customize buttons**.
2. Tap **Short press** and choose a shortcut option. By default this option is set to go to the previous screen.

Navigation

The touchscreen responds best to a light touch from the pad of your finger. Using excessive force or a metallic object on the touchscreen may damage the tempered glass surface and void the warranty.

Tap

Lightly tap the screen to launch an app or select a menu item.



Swipe

Lightly drag your finger vertically or horizontally across the screen to access panels.



Drag

Touch and hold an item, and then move it to a new location.



Rotate

The Galaxy Watch4 Classic features a physical bezel that you can rotate with your fingers. The Galaxy Watch FE has a digital bezel. Lightly press and drag your finger clockwise or counterclockwise using the digital bezel on the edge of the screen to move through a list.



Change the watch face

The first screen when you turn on the Galaxy Watch FE is the watch face. You can choose a watch face with different colors, styles, and information displayed.

From your smartphone:

1. From the smartphone, tap  **Galaxy Wearable** > **Watch faces**.
2. Tap a watch face to select it.

From your watch:

1. Touch and hold the watch face.
2. Swipe left and tap **Edit on phone** or swipe right and tap  **Add watch face**.
3. Tap **Customize** to select a background color and items to display on the watch face.

Status indicators

Show icons on the watch screen that indicate the watch status.

- From  **Settings**, tap  **Advanced features** > **Status indicators**.

Quick panel

Instead of navigating through the Settings menu, you can access commonly used settings through the Quick panel, where you can also access the Status bar.







- Swipe down from the top of the watch screen to open the Quick panel.
 - Tap a Quick setting icon to turn it on or off.
 - Touch and hold a Quick setting icon to open the setting.



Status bar



Indicator icons display at the top of the screen in the Status bar. Swipe down from the top of the watch screen to access the Status bar.

Indicator icons

	Battery full
	Bluetooth connected
	Bluetooth enabled, but not connected
	Wi-Fi connected
	Airplane mode
	LTE network connected (LTE model only)
	Signal strength (LTE model only)

Tiles

Tiles are shortcuts to apps and features that you can add as a screen on your watch.

- From the watch face, swipe left to access tiles.
 - To add tiles, swipe to the end of the tiles screens, and tap  **Add tiles**.
 - To move tiles, touch and hold a tile, and then drag it to the desired location.
 - To delete tiles, touch and hold a tile, and then tap  **Remove**.

Manage tiles from your smartphone

- From the smartphone, tap  **Galaxy Wearable**, tap **Tiles**.
 - Drag to reorder tiles.
 - Tap a tile to add it.
 - Tap  **Remove** to delete tiles.

Notifications

Stay up to date with events, notifications, and messages from your smartphone. When you receive a notification, information about the notification, such as its type, is displayed on the screen while the watch is vibrating.

- From the watch screen, swipe right and tap a notification for details.



Sleep mode

Sleep mode mutes all alerts, except for alarms and notifications. This keeps the screen off and mutes most sounds while you sleep.

- From Settings, tap  **Modes** > **Sleep**. Here you can schedule sleep mode.

Do not disturb

Use these options to determine block out time where notifications are turned off, and during which time periods you want to enter this mode.

- From the Quick settings panel, tap  to put the watch in Do not disturb mode.



TIP You can also access Do not disturb from the Settings menu. From Settings, tap  **Notifications** > **Do not disturb**.

Water lock mode

You can use Water lock mode to exercise in the water while wearing your watch. While in Water lock mode, touchscreen, wake-up gestures, and watch always on will be disabled.

- From the Quick settings panel, tap  to put the watch in Water lock mode.



TIP You can also enable Water lock mode from the Setting menu. From Settings, tap  **Advanced features** > **Water lock**. Tap  to enable.

Exit water lock mode

1. Press and hold the **Home** button for two seconds to turn off the mode. The watch will make sounds to eject water from the speaker.
2. Press the **Home** button to stop the sound.
3. Shake the watch to remove any water from the pressure sensor.

Theater mode

Theater mode keeps the screen turned off and silences all sounds.

- From Settings tap  **Modes** > **Theater**, to put the watch in Theater mode.

Enter text

Text can be entered by speaking, drawing, or by using a keyboard.







Default keyboard

Select a default keyboard type for text input.

- From  **Settings**, tap  **General** > **Input** > **Keyboard list and default** and select your default keyboard.



Choose a keyboard

When you need to enter text from your watch, you can choose which keyboard you prefer.



- Tap an option for text input:
 - Tap  **Voice input** and speak the message you want to enter.
 - Tap  **Write** to draw letters.
 - Tap  **Emoji** to add emojis to your message.
 - Tap  **Samsung Keyboard** to use the QWERTY keyboard.
 - Tap  **Numbers and symbols** to use add numbers or symbols to your message.

Keyboard settings

Change the Samsung keyboard settings.

- From  **Settings**, tap  **General** > **Input** > **Samsung keyboard**, and tap options to customize:
 - **Input languages:** Select languages for text input.
 - **Smart typing:** Customize features like predictive text, auto capitalize, and more.
 - **Swipe, touch, and feedback:** Set the watch to vibrate or play sounds when you tap a key on the keyboard or enable swipe controls.
 - **Reset to default settings:** Return your keyboard to the default settings and remove word predictions and personalized data.

Quick responses

- From  **Settings**, tap  **General** > **Input** > **Quick responses** to customize.

Apps

Navigate the apps screen

Tools

Media

Health

Google

Microsoft



Navigate the apps screen

The Apps list displays all preloaded and downloaded apps. Apps can be downloaded from the Google Play store.

Uninstall apps | Apps Settings

- From the watch screen, swipe up from the bottom of the screen to open the Apps screen.
 - To scroll through the list of apps, swipe up and down.
 - To review a list of recently opened apps, tap  **Recent apps**.



Uninstall apps

Uninstall apps you have downloaded.

1. From Apps on your watch, touch and hold an app.
2. Tap  **Uninstall**. This option is not available for all apps.

Apps Settings

Customize how apps are displayed on the Apps screen.

- From  **Settings**, tap  **Apps**, and tap an option to customize:
 - **Choose default apps:** Choose which apps to use for making calls, sending messages, and more.
 - **Health platform:** Choose which Health platform to use.
 - **App list:** Review a list of the apps on your watch.
 - **Permission manager:** Configure permissions for each installed app.
 - **Samsung app updates:** Check for updates for some preinstalled Samsung apps.

Tools

The following apps are useful tools that come pre-installed or downloaded over-the-air to your device.

[Alarm](#) | [Bixby](#) | [Calculator](#) | [Calendar](#) | [Compass](#) | [Contacts](#) | [Find My Phone](#) | [Reminder](#) | [Samsung Global Goals](#) | [SmartThings](#) | [Samsung Pay](#) | [Stopwatch](#) | [Timer](#) | [Voice Recorder](#) | [Weather](#) | [World clock](#)

Alarm

Set an alarm to ring at a specific time.

Create an alarm

Create an alarm event. You can set one-time or recurring alarms.

1. From Apps, tap  **Alarm**.
2. Tap **Add on watch** and enter the time.
3. Tap **Next**, and select the days to repeat the alarm.
4. Tap **Save** when finished.





NOTE You can also access alarms saved on your phone. To add an alarm on your smartphone, tap **Add on phone**.

Stop or snooze an alarm

- Tap and drag  **Cancel** to stop an alarm or tap and drag  **Snooze** to snooze.

Delete an alarm

You can disable alarms or delete them.

- From  **Alarm** tap an alarm from the list of alarms on your watch and smartphone.
 - To disable the alarm, tap .
 - To delete the alarm, touch and hold the alarm and tap **Delete**.

Bixby

Bixby is a voice service that helps you use your watch more conveniently. You can talk to Bixby to launch a function or provide you with information. To use Bixby, your mobile device must be connected to a Wi-Fi or mobile network, and you must sign in to your Samsung account.

1. From Apps, tap  Bixby.
2. Follow the prompts to set up Bixby.



TIP You can also press and hold the **Home** button to access Bixby.



Calculator

The Calculator app features basic math functions.

- From Apps, tap  Calculator, and enter the math equation.

Calendar

Access events scheduled on the smartphone.

1. From Apps, tap  Calendar.
2. Swipe up or down for a list of upcoming events.
 - Tap  for month view.
 - Tap  for week view.
 - Tap **Show on phone** to edit and add events.

Compass

Use your watch as a compass. The first time you use the Compass app, it guides you on how to calibrate your watch.



- From Apps, tap  Compass.

Contacts

Access your smartphone's contact list on your watch.



Find a contact

You can search for a contact or scroll through the list to find one by name.

- From  **Contacts**, tap  **Search**, and then enter characters to find contacts that match.



Call or message a contact

You can send a message or make a phone call from Contacts.

- From  **Contacts**, tap the contact you want to connect with, and tap an option:
 -  **Call**: Begin a phone call with the contact.
 -  **Message**: Type a message to the contact.



Find My Phone

If you misplace your smartphone, your watch can help you find it.

1. From Apps, tap  **Find My Phone**.
2. Tap **Ring**.
 - The smartphone vibrates and the screen turns on.
3. Drag  **Dismiss** on your smartphone or tap **Stop** on the watch.

Find your Watch

You can also locate your watch by making it light up and make sounds from the Galaxy Wearable app.



1. From  **Galaxy Wearable**, tap  **Find My Watch**.
2. Tap **Start**.
3. Tap **Stop** on the smartphone or drag  on the watch.

Reminder

Add reminders for events and set alarms outside of the Calendar app.

Create a reminder

Set up and track reminders on your watch:

1. From Apps, tap  **Reminder**.
2. Tap  **Write**, and then enter the reminder information.
3. Set the date and repeat options, then tap **Done**.
4. Tap **Save** when finished.

Complete a reminder

To mark reminders as complete:

- From  **Reminder**, tap the **checkbox** beside a reminder to set it as complete.
 - To review completed reminders, tap **Completed**.

Samsung Global Goals

Learn more about the Global Goals initiative and contribute towards donations that support these causes with ads from this app.

- From Apps, tap  **Samsung Global Goals**.

SmartThings

SmartThings allows you to control, automate, and monitor your home environment through a mobile device to fit your specific needs. You can use the app to connect multiple devices at once or one device at a time. Check the status of your devices by looking at the dashboard.

- From Apps, tap  **SmartThings**.

 **NOTE** Non-Samsung connected device errors or defects are not covered by the Samsung warranty; contact the non-Samsung device manufacturer for support.

Samsung Pay

Pay almost anywhere that accepts a debit, credit, or gift card. Samsung Pay supports Near Field Communication (NFC) to allow quick and secure payment through standard credit card readers. For more information, see samsung.com/us/samsung-pay.

Set up Samsung Pay

1. From Apps, tap  **Samsung Pay**.
2. Follow the prompts to complete the setup.

Make a payment

1. From any screen, press and hold the **Back** key to launch  **Samsung Pay**.
2. Swipe to select a card.
3. Hold the watch near an NFC reader to pay.



NOTE You can use Samsung Pay for up to 5 transactions without the smartphone. This may vary depending on the bank/institution issuing the account.

Stopwatch

The Stopwatch lets you time events down to a hundredth of a second.



1. From Apps, tap  **Stopwatch**.
2. Tap **Start** to begin timing.
 - To keep track of lap times, tap **Lap**.
3. Tap **Stop** to end timing.
 - To continue timing after stopping the clock, tap **Resume**.
 - To reset the Stopwatch to zero, tap **Reset**.

Timer

Set a countdown timer for up to 99 hours, 59 minutes, and 59 seconds.

Set a timer

Create an alarm event. You can set one-time or recurring alarms.







1. From Apps, tap  **Timer**.
2. Tap a time or  **Custom** to set the Timer.
3. Tap  **Start**.

Stop the timer

- Drag  **Cancel** or  **Restart** when the timer goes off.

Voice Recorder

Use your voice to record memos.

1. From Apps, tap  **Voice Recorder**.
2. Tap  **Record** and begin recording your message.
 - To convert your speech to text, tap  **Speech-to-text** before recording.
 - To pause the recording, tap  **Pause**.
3. Tap  **Stop** when you are finished.
 - You can access your voice recordings, from  **Recordings**.

Weather

Access weather information on the watch for locations set on the smartphone.

1. From Apps, tap  **Weather**, tap **Add** and follow the prompts.
2. Swipe through the screens to review the weather information.
3. To add a city, tap the location, and tap **Manage locations**.



World clock

Keep track of the current time in multiple cities around the globe.

1. From Apps, tap  **World clock**.
2. Tap a city for the time and temperature at that location.
 - To add a city to the World clock, tap **Edit on phone**.

Media

The following media apps come pre-installed or downloaded over-the-air to your device.

[Buds controller](#) | [Camera controller](#) | [Gallery](#) | [Media controller](#) | [Music](#) | [Messages](#) | [Phone](#)



Buds controller

Control your earbuds with your watch. Connect your earbuds directly to your watch or to the Galaxy Wearable app on your smartphone.

1. From Apps, tap  **Buds controller**.
2. Follow the instructions to connect your earbuds.



Camera controller

You can use Camera controller to take pictures or record videos using the camera on your smartphone with your watch.

1. From Apps, tap  **Camera controller**. A preview will display on your watch of your smartphone's screen.
2. Tap  **Capture** or  **Record** on your watch to take pictures or videos using your smartphone's camera.

Gallery

Access and manage images.



1. From Apps, tap  **Gallery**.
2. Swipe through the image list and then tap an image to open it.
 - To zoom in or out, double tap the image.
 - To delete an image, touch and hold the image, and then tap  **Delete**.

Import and export images



Images can be exchanged between your watch and smartphone.

Import images from your smartphone

Send images or entire albums from your smartphone to your watch.

1. From the smartphone, tap  **Galaxy Wearable**, tap  **Watch settings**.
2. Tap  **Manage content** > **Add images**.
3. Select files or albums and tap **Done**.

To automatically sync images on your smartphone with your watch:

1. From the smartphone, tap  **Galaxy Wearable**, tap  **Watch settings**.
2. Tap  **Manage content** > **Auto sync albums** to enable. Images sync while the watch battery power is at least 15 percent.
 - **Albums to sync:** Select which Gallery albums to sync to your watch.
 - **Auto sync image limit:** Set a limit to the number of images that can be synced to your watch.
 - **Auto sync latest story:** Sync images immediately after creating them.

Take a screenshot

Capture an image of your screen. It is automatically saved to the Gallery app.

- From any screen, press the **Home** and **Back** buttons at the same time.

Media controller

You can use the Media controller to connect to a computer, smartphone, or tablet using Bluetooth and control media with your watch.

To connect:

1. From Apps, tap  **Media Controller**.
2. Tap a device in the list to connect your watch.
3. Use the media controls on your watch.



Music

Play music from your watch.



1. From Apps, tap  **Music**.
2. Tap an album, playlist, or track to begin playing.

Import music

Import music saved on your smartphone to your watch.

1. From the smartphone, tap  **Galaxy Wearable**, tap  **Watch settings**.
2. Tap  **Manage content** > **Tracks on watch** >  **Add**.
3. Select files and tap **Add to watch**.

To sync recently added music on your smartphone with your watch:

1. From the smartphone, tap  **Galaxy Wearable**, tap  **Watch settings**.
2. Tap  **Manage content** > **Auto sync**, music syncs while the watch's battery power is at least fifteen percent.

Messages

Access messages and reply to or call the sender using the watch.

Open messages





You may incur additional charges for receiving messages while you are roaming.

- From the notifications screen, tap message to open it.



Send messages

Create and send messages from your watch.

1. From Apps, tap  **Messages** >  **Compose**.
2. Tap **Recipient** to enter a phone number, or  **Contacts** to add a number you have saved.
3. Tap **Message** to write a custom message.
4. Swipe up from the bottom of the screen to choose a keyboard and compose your message.
5. Tap  **Send**.

Delete messages

Delete messages from your watch.

1. From Apps, tap  **Messages**.
2. Touch and hold a conversation to select it, and tap **Delete**.

Phone

Make and answer calls on your smartphone from your watch.



Make a call

Make a call from your watch.

1. From Apps, tap  **Phone**.
2. Tap  **Keypad** and enter a number or tap  **Contacts** and select a contact to call.
3. Tap  **Dial**.

Answer or reject a call

Answer or reject incoming calls on your watch.

- On the incoming call screen, drag  **Answer** or  **Decline** to answer or reject a call.



End a call

End a call from your watch.

- Tap  **End** when you are ready to end your call.

Gestures

Use gestures as shortcuts on the watch.

- From  **Settings**, tap  **Advanced features**, and tap an option under Gestures:
 - **Answer calls:** Shake your arm twice bending at the elbow to answer incoming calls.
 - **Dismiss alerts and calls:** Rotate your wrist twice to dismiss alarms or decline incoming calls.
 - **Quick launch:** Enable to open a chosen shortcut within the first 5 seconds after the screen turns on, when you make a fist and bend your wrist down and then up again twice.
 - **Bixby:** Enable the Bixby feature.

Health

The following health apps come pre-installed or downloaded over-the-air to your device.

[Samsung Health](#) | [Samsung Health Monitor](#)



Samsung Health

Samsung Health helps you manage your wellness and fitness. Set fitness goals and regularly record and check your progress.

When the watch is synced with the Samsung Health app, you can save and manage health-related data and receive useful information about your health every day.

Only your most recent activity records are stored on your watch. You can review previous data on the smartphone where the Samsung Health app is installed.

- From the Apps screen, tap  **Samsung Health**.



CAUTION The information gathered from this device, Samsung Health, or related software is not intended for use in the diagnosis of disease or other conditions, or in the cure, mitigation, treatment or prevention of disease.

The accuracy of the information and data provided by this device and its related software, including heart rate readings, may be affected by factors such as environmental conditions, skin condition, specific activity performed while using/wearing the device, settings of the device, user configuration/user-provided information, placement of the sensor on the body, and other end-user interactions.

Before you start exercising

Although the Samsung Health application is a great companion to your exercise routine, it is always best to make sure you consult with your physician before beginning any exercise regimen. While moderate physical activity, such as brisk walking, is safe for most people, health experts suggest that you talk with your doctor before you start an exercise program, particularly if you have any of the following conditions:

- Heart disease; Asthma or lung disease; Diabetes, or liver or kidney disease; and Arthritis.

Before beginning your exercise regimen check with your doctor if you have symptoms suggestive of heart, lung, or other serious disease, such as:

- Pain or discomfort in your chest, neck, jaw, or arms during physical activity;
- Dizziness or loss of consciousness;
- Shortness of breath with mild exertion or at rest, or when lying down or going to bed;
- Ankle swelling, especially at night;
- A heart murmur or a rapid or pronounced heartbeat;
- Muscle pain when walking upstairs or up a hill that goes away when you rest.

It is recommended that before engaging in an exercise routine, you consult with your doctor or medical practitioner. If you are unsure of your health status, have several health problems, or are pregnant, you should speak with your doctor before starting a new exercise program.

Daily activity

Access a summary of your daily activity broken down by your step count, active time, and active calories.



- From  **Samsung Health**, tap  **Daily activity** and swipe down to open a graph of your activity.

Steps

Your watch counts your number of steps, measures the distance traveled, calories burned, and floors climbed.

- From  **Samsung Health**, tap  **Steps** to open a graph of your step count records.

To set your steps target:

1. From  **Samsung Health**, tap  **Steps**.
2. Swipe to the bottom of the screen, and tap **Set target**.
3. Set your target step count, and tap **Done**.



Exercise

Record your exercise information using Samsung Health's exercise feature.

When your watch and smartphone are connected, this feature uses your smartphone's location information.

Work out

Choose and track your work outs with your watch.

1. From  **Samsung Health**, swipe to  **Exercise**.
2. Swipe to choose an activity type.
3. Press and hold the **Back** button to pause the workout.
 - Swipe right to access the exercise controls.
 - Press the **Resume** to resume the workout.
 - Tap **Finish** to complete your workout and review your workout summary.
4. Swipe to and tap **View log** to open your workout log.



TIP You can also press and hold the **Back** button to access the Exercise list and begin working out.

Learn more: [Customize buttons](#)



Workouts this week

Keep track of how many times you work out, how long, and how many calories you burn each week.

- From  **Samsung Health**, tap **Workouts this week** and review your work out history from the watch.

Sleep

Automatically track your sleep patterns.



1. From  **Samsung Health**, tap  **Sleep**.
2. Swipe up to review your sleep data.

Food

Keep track of your calorie intake from food.



1. From  **Samsung Health**, tap  **Food**.
2. Tap **Enter** when you eat something to add following information:
 - **Meal type**: Enter the type of meal you had.
 - **Cal**: Swipe up or down to select the calories consumed.

To set your daily calorie target:

1. From  **Samsung Health**, tap  **Food**.
2. Swipe down and tap **Set target**.
3. Swipe to set the number.
4. Tap **Done**.

Body composition

Keep track of your Body composition.



1. From  **Samsung Health**, tap  **Body composition**.
2. Tap **Measure** and enter your information.
3. Follow the prompts to measure your body composition.
 - After a moment, your body composition is displayed on the screen.

Heart rate

Measure and record your heart rate. Take heart rate measurements when you are seated and relaxed.



Track your heart rate

The watch can be configured to automatically measure and track your heart rate.

1. From  **Samsung Health**, tap  **Heart rate**.
2. Tap **Measure** to begin measuring your heart rate.
 - After a moment, your heart rate is displayed on the screen.
3. Swipe up to view your minimum and maximum heart rate per hour.
4. Tap **Settings** to review additional settings for using the Heart rate feature such as measurement frequency and alerts.



Stress

Keep track of your stress. Breathing exercises are also available to help reduce stress.

1. From  **Samsung Health**, tap  **Stress**.
2. Tap **Measure** and follow the prompts to measure your current stress level.
 - After a moment, your stress level is displayed on the screen.
3. Swipe up to view your breathe duration.
4. Tap **Settings** to review additional settings for using the breathe feature such as measurement frequency.



Breathing exercise

Use the Breathe feature to help reduce stress by doing a breathing exercise.

1. From  **Samsung Health**, tap  **Stress**.
2. Follow the prompts and swipe up to review the Breathe feature, and adjust the number of breathing cycles.
3. Tap **Start** to begin.



Blood oxygen

Track your blood oxygen levels through the Samsung Health app.



1. From  **Samsung Health**, tap  **Blood oxygen**, and tap **Measure** to begin.
2. Follow the prompts to position the device and your arm properly.
3. Tap **OK** to start measuring blood oxygen.

Water



Record and track how many glasses of water you drink each day.

1. From  **Samsung Health**, tap  **Water**.
2. Tap your selected cup size when you drink a glass of water to add to your target count.
 - To decrease the count, tap **Delete**.

To set your cup size:



1. From  **Samsung Health**, tap  **Water**.
2. Swipe down and tap **Set cup size**.
3. Swipe to select the fluid ounces.
 - Tap **New cup** to create a custom cup size.

To set your daily water target:

1. From  **Samsung Health**, tap  **Water**.
2. Swipe down and tap **Set target**.
3. Swipe to set the number.
4. Tap **Done**.

Cycle tracking

Record and track your menstrual cycle.

- From  **Samsung Health**, tap  **Cycle tracking**.
 - Tap **Enter period** to record your menstrual cycle.
 - Swipe up on the screen to review your ovulation and predicted period information.
 - Tap **Add log** to record your symptoms.

Together

Compete with other Samsung Health users.

Steps leaderboard

Add challenges through Samsung Health on your smartphone.

- From Apps, tap  **Samsung Health** >  **Together** > **Add on phone**. Here you can add friends and challenges.



Samsung Health Monitor

Use the Samsung Health Monitor app to track your blood pressure and record electrocardiogram (ECG) measurements, analyze them, and share the results with experts.

To review detailed reports of your blood pressure and ECG readings on your smartphone, install the Samsung Health Monitor app. You can download the app from the Galaxy Store or the Google Play store.

1. From your watch, tap  **Samsung Health Monitor**. If necessary, update the app to the latest version.
2. Tap **Continue** and create your profile.

Measure ECG

Use your Galaxy watch to record ECG for 30 seconds similar to a standard single-lead ECG. The ECG Monitor app also checks the recording for signs of Atrial Fibrillation—a common form of irregular heart rhythm.

Requires Samsung Galaxy smartphone with Android 7 or later, and Samsung Health Monitor app (available only at the Samsung Galaxy app store).



CAUTION The ECG app is not intended for users with known arrhythmias other than atrial fibrillation or users under 22 years old. Users should not interpret or take clinical action based on the device output without consultation of a qualified healthcare professional. The ECG app is not intended to replace traditional methods of diagnosis or treatment.

1. From  **Samsung Health Monitor**, tap **ECG**.
2. Rest your finger lightly on the **Home** button to begin the ECG.
 - After a moment, your ECG is displayed on the screen.
3. Tap **Add** to add any symptoms you are experiencing.
4. Tap **Done** when you are finished.

Share your report

You can review your ECG readings as daily, weekly, and monthly charts, or access detailed reports for each measurement. You can share the PDF report of your ECG recording with your healthcare provider using Samsung Health Monitor app on your compatible Galaxy smartphone.

1. From your smartphone, tap  **Samsung Health Monitor**.
2. Tap the **ECG** tab to open your measurements.
3. Tap **See details** to open the latest report or **View history** for all available reports.
4. Tap **Share this report** and choose a sharing method to send a PDF.

Google

Enjoy these apps from Google. Certain apps require a Google Account.

Learn more: google.com

[Maps](#) | [Messages](#) | [Play store](#)



Maps

Get directions and other location-based information. You must enable location services to use Google Maps.

Learn more: [Location](#)

- From Apps, tap  **Maps**.



Messages

Send and receive messages over Wi-Fi or data with Google's official app for texting and chat.

- From Apps, tap  **Messages**.



Play store

Find new, recommended, and essential apps as well as watch faces and games in the Google Play store.

- From Apps, tap  **Play store**.

Microsoft

The following Microsoft apps may be preloaded on your device. Apps can be downloaded from Galaxy Store and the Google Play store.



Outlook

Open new emails on your watch.

1. From Apps, tap  **Outlook**.
2. Tap a message to review its content.

Open calendar events

Open your Outlook calendar events on your watch.

- From  **Outlook**, tap an event to open the content.

Notification settings

Customize Microsoft Outlook

- From  **Outlook**, tap **Notifications** and tap an option to customize:
 - **Mail:** Choose to receive notifications in the same way as your smartphone, or set a vibration option.
 - **Calendar:** Choose to receive notifications in the same way as your smartphone, or set a vibration option.

Settings

Access Settings

Connections

Notifications

Sounds and vibration

Display

Device maintenance

Accessibility

Security and privacy



Accounts and backup

Other settings



Access Settings

You can personalize your device by configuring various setting options.

- From Apps, tap  **Settings**, or swipe down from the top of the screen to open the status panel and tap  **Settings**.

Connections

Manage connections between your device and a variety of networks and other devices.

[Bluetooth](#) | [Wi-Fi](#) | [NFC and contactless payments](#) | [Disconnection alerts](#) | [Airplane mode](#) | [Mobile networks](#) | [Data usage](#)

Bluetooth

Use Bluetooth to connect the watch to a smartphone or an optional headset for playing music (headset not included).

1. From  **Settings**, tap  **Connections** > **Bluetooth**.
2. Tap  to turn on the feature.



Wi-Fi

Activate the Wi-Fi feature to connect to a Wi-Fi network.

1. From  **Settings**, tap  **Connections** > **Wi-Fi**.
2. Tap  to turn on the feature.

Connect to a Wi-Fi network

This feature is available when the watch is not connected to the smartphone through Bluetooth.



1. From  **Settings**, tap  **Connections** > **Wi-Fi**.
2. Tap a network from the **Available networks** list.
 - Networks that require a password display a lock icon.
 - To manually add a hidden network, tap **Add network** at the bottom of the list.
3. Enter the password if required, and tap **Connect**.



NOTE Once the watch connects to a Wi-Fi network, the watch reconnects to that network each time it is available without requiring a password. To prevent the watch connecting to the network automatically, select the network, and then tap **Forget**.

NFC and contactless payments

Near Field Communication (NFC) allows you to communicate with another device without connecting to a network. Make payments and buy tickets for transportation or events after downloading and configuring the required apps.

1. From  **Settings**, tap  **Connections** > **NFC and contactless payments**.
2. Tap  to enable the feature.
3. Tap **Payment** to set the default payment app for mobile payments.
 - To use a payment app that is open, tap **Pay with open app**.

Make payments with the NFC feature

Before you can use the NFC feature to make payments, you must register for the mobile payment service. To register or get more information about the service, contact your service provider.

- Touch the top of the watch's touchscreen to the credit card reader.

 **NOTE** The payment services list may not include all available payment apps.

Open with NFC

You can select supported apps to open with NFC.

1. From  **Settings**, tap  **Connections** > **NFC and contactless payments**.
2. Tap **Others**, and select an app.

Disconnection alerts



Receive alerts when disconnected from Bluetooth.

1. From  **Settings**, tap  **Advanced features** > **Disconnection alerts**.
2. Tap an alert style to select it.

Airplane mode



Airplane mode disconnects your device from all networks and turns off connectivity features, such as phone calls and Wi-Fi.

- From  **Settings**, tap  **Connections** > **Airplane mode** to enable this option.

 **TIP** You can also access Airplane mode from Quick settings. Swipe down from the top of the watch, and tap .



Mobile networks

Customize your mobile networks. This feature is only available on LTE models. When you are not subscribed to a service provider's mobile plan, the mobile network is turned off to save battery power and network services may not be available.

1. From  **Settings**, tap  **Connections**.
2. Tap **Mobile networks**, and tap an option for mobile network use.
3. Swipe down and tap **Mobile plans** to review available mobile plans for your device.

Data usage

Explore options for your data plan. This feature is only available on the LTE model.

1. From Apps, tap  **Settings**, tap  **Connections**.
2. Tap **Data usage** and tap an option:
 - **Start billing cycle on:** Change the monthly date to align with your carrier's billing date (if applicable).
 - **Set data limit:** Enable the data limit feature.
 - **Data limit:** Customize your data limit.



Notifications

You can prioritize and streamline app alerts by changing which apps send notifications and how notifications alert you.

[Notification settings](#) | [Advanced notification settings](#)



Notification settings

Coordinate notifications between your smartphone and watch.

- From  **Settings**, tap  **Notifications**, and tap an option to enable it:
 - **Do not disturb:** Enable to block sounds and notifications while this mode is on.
 - **Advanced settings:** Use these options to customize your advanced notification settings.

Advanced notification settings

Use these options to customize your advanced notification settings.

- From  **Settings**, tap  **Notifications**, and tap options under **Advanced settings** to enable:
 - **New notification indicator on watch face:** Show indicator for unread notifications.
 - **Read notifications aloud:** When headphones are connected the watch can read your notifications aloud.
 - **Show with details:** Show the details of new notifications automatically.
 - **Turn on screen:** Turn on the watch screen when notifications are received.
 - **Auto turn on watch notifications for new phone apps:** Automatically turn on notifications for newly installed apps.



Sounds and vibration

Configure the vibrations used to indicate notifications, screen touches, and other interactions.

[Sound mode](#) | [Vibration](#) | [Call vibration](#) | [Notification vibration](#) | [System vibration](#) | [Volume](#) | [Ringtone](#) | [Notification sound](#) | [System sounds](#)



Sound mode

Switch between sound modes, while preserving the individual sound settings you have made.

1. From  **Settings**, tap  **Sounds and vibration**.
2. Tap an option:
 - **Sound:** Enable sounds for notifications and alerts.
 - **Vibrate with sound:** Set your device to vibrate in addition to ringing when you receive an alert (This option is only available if Sound is enabled).
 - **Vibrate:** Use vibration only for notifications and alerts.
 - **Mute:** Set your device to make no sounds.



Vibration

Set how long and intensely the device vibrates for notifications.

1. From  **Settings**, tap  **Sounds and vibration** > **Vibration**.
2. Select options under **Vibration duration** and **Vibration intensity** to set your preference.

Call vibration

Vibrate for calls.

1. From  **Settings**, tap  **Sounds and vibration**.
2. Tap **Call vibration** and select a vibration pattern.

Notification vibration

Choose a vibration pattern for new notifications.

- From  **Settings**, tap  **Sounds and vibration** > **Notification vibration** and select a vibration pattern.



System vibration

Enable vibrations when the watch screen is tapped.

- From  **Settings**, tap  **Sounds and vibration** > **System vibration** to enable.

Volume

Set volume levels.

1. From  **Settings**, tap  **Sounds and vibration** > **Volume**.
2. Tap a mode to customize the volume level.

Ringtone

Choose from preset ringtones or add your own.

1. From  **Settings**, tap  **Sounds and vibration** > **Ringtone**.
2. Tap a ringtone to hear a preview and select it.



Notification sound

Choose from preset notification sounds.

1. From  **Settings**, tap  **Sounds and vibration** > **Notification sound**.
2. Tap a notification sound to hear a preview and select it.

System sounds

Enable sounds for actions like tapping the screen and charging the watch.

1. From  **Settings**, tap  **Sounds and vibration**.
2. Tap an option under **System sounds**:
 - **System sound volume**: Drag the slider to adjust the system volume.
 - **Ticking**: Hear a ticking sound.
 - **Hourly chime**: Hear a sound and feel a vibration at the start of each hour.
 - **Touch interactions**: Play tones when you touch or tap the screen to make selections.
 - **Dialing keypad**: Play a tone when dialing numbers on the keypad.
 - **Samsung keyboard**: Play a sound when typing with the Samsung keyboard.
 - **Charging**: Play a sound when a charger is connected.
 - **Unlock**: Play a sound when you lock or unlock the screen.



Display

You can configure the screen brightness, timeout delay, font size, and many other display settings.

[Adjust screen brightness](#) | [Always on Display](#) | [Screen wake-up](#) | [Set the screen timeout](#) | [Show last app](#) | [Font](#) | [Touch sensitivity](#) | [Show charging info](#)



Adjust screen brightness

Manually adjust the brightness of the display.

- From  **Settings**, tap  **Display** and select an option:
 - **Brightness**: Manually adjust the brightness of the display.
 - **Adaptive brightness**: Set the watch to automatically adjust the brightness depending on ambient light conditions.



Always on Display

Keep the screen on without unlocking your device using Always On Display (AOD).

- From  **Settings**, tap  **Display**, and tap **Always on Display** to enable the feature.

Screen wake-up

Use a gesture to turn on the watch screen.

- From  **Settings**, tap  **Display**, and tap an option under **Screen wake-up** to enable:
 - **Raise wrist to wake:** Lift your wrist to turn on the watch screen.
 - **Touch screen to wake:** Touch the watch screen to turn it on.
 - **Show media controls:** Show controls on your screen when you start playing audio or video on your mobile device.

Set the screen timeout

Set the length of time the watch waits before turning off the display's backlight.

- From  **Settings**, tap  **Display** > **Screen timeout**, and select a timeout value.



Show last app

Set the length of time the watch displays the last app used when you turn the screen on.

- From  **Settings**, tap  **Display** > **Show last app**, and select a timeout value.

Font

Customize the font style and size on your watch.

- From  **Settings**, tap  **Display**, and tap an option under **Font** to customize:
 - **Font style:** Select a font.
 - **Bold font:** Enable to display text in bold.
 - **Font size:** Choose from small, medium, and large.

Touch sensitivity

Set the watch to allow use of the touch screen with gloves on.

1. From  **Settings**, tap  **Display** > **Touch sensitivity**.
2. Tap  to enable this feature.

Show charging info

Display the battery level until full.

- From  **Settings**, tap  **Display** > **Show charging info** to enable the feature.

Device maintenance

Review the status of your device's battery, storage, and memory. You can also automatically optimize your device's system resources.

[Battery](#) | [Storage](#) | [Memory](#) | [Watch only mode](#) | [Touch bezel](#) | [Text to speech](#) | [Date and time](#) | [Orientation](#) | [Transfer watch to new phone](#) | [Reset the Watch](#)

Battery



Review your battery level percentage and remaining hours.

- From  **Settings**, tap  **Battery and device care** > **Battery** to open the remaining battery life for your watch.

Power saving mode

Activate Power saving mode to save battery power by limiting the watch's functions, such as:

- Use a grayscale Home screen.
- Turn off all functions except calls, messages, and notifications.
- Turn off Wi-Fi and mobile networks (if applicable).
- Limit performance.

1. From  **Settings**, tap  **Battery and device care** > **Battery**.
2. Tap **Power saving** to enable the feature.

To disable Power saving mode:

- From the Home screen, swipe from the top of the screen down to open the Quick settings panel. Tap  **Power saving** to turn off the feature.



Storage

Review your storage capacity and detailed usage by category and file type.

- From  **Settings**, tap  **Battery and device care** > **Storage**.



Memory

Check the amount of available memory. You can close background apps and reduce the amount of memory you are using to speed up your device.

1. From  **Settings**, tap  **Battery and device care** > **Memory**.
2. Tap **Clean now** to free up memory by stopping background apps.



Watch only mode

Activate Watch only mode to save battery power by limiting the watch's functions to only showing the time.

1. From  **Settings**, tap  **Battery and device care** > **Battery** > **Watch only**.
2. Tap **Turn on**.
 - Press the **Home** button to show the time.
 - Press and hold the **Home** button to turn watch only mode off.



Touch bezel

On the Galaxy Watch FE you can disable the digital rotating bezel.

1. From  **Settings**, tap  **General** > **Touch bezel**.
2. Tap  to enable the bezel feature.
 - Tap **Vibration feedback** to vibrate when using the touch bezel.



Text to speech

To set accessibility settings related to Text to speech:

- From  **Settings**, tap  **General** > **Text-to-speech** and select a mode:
 - **Preferred engine:** Choose your default TTS engine.
 - **TTS engine settings:** Install voice data for use with text-to-speech and review the TTS version information.
 - **Language:** Choose the language for spoken text.
 - **Speech rate:** Set the speed at which the text is spoken.

Date and time

You can set the date and time manually. These options are only available when your watch is not connected to your mobile device.



- From  **Settings**, tap  **General** > **Date and time**.
 - **Automatic:** Use the network to set date and time.
 - **Set date:** Set the date manually.
 - **Set time:** Set the time manually.
 - **Select time zone:** Select the time zone manually.

Orientation

The screen orientation changes based on your choices.



TIP For accurate ECG measurements, choose the orientation that matches how you wear your watch.

- From  **Settings**, tap  **General** > **Orientation** and select an option:
 - Under Wrist, select the hand you are wearing the watch on.
 - Under Button position, select which side of the screen the buttons are on.

Transfer watch to new phone



Connect your watch to a new mobile device.

Learn more: [Back up data](#)

- From  **Settings**, tap  **General** > **Transfer watch to new phone** and follow the prompts.

Reset the Watch

Reset settings to their factory default values and delete all data.

1. From  **Settings**, tap  **General** > **Reset**.
2. Tap **Reset** again to confirm.

Accessibility



There are accessibility settings for people who need help seeing, hearing, or otherwise operating their device. Accessibility services are special features that make using the device easier for everyone.

Learn more: accessibility@sea.samsung.com

[TalkBack](#) | [Vision enhancements](#) | [Hearing enhancements](#) | [Interaction and dexterity](#) | [Advanced settings](#) | [Installed apps](#)



TalkBack

Receive spoken feedback when using your device, such as what you touch, select, or activate.

1. From  **Settings**, tap  **Accessibility** > **TalkBack**.
2. Tap  to enable the feature.
 - To configure TalkBack, tap **Settings**.



Vision enhancements

You can configure Accessibility features to assist with visual aspects of your device.

- From  **Settings**, tap  **Accessibility** > **Vision enhancements** for the following options:
 - **High contrast fonts:** Adjust the color and outline of fonts to increase the contrast with the background.
 - **Color correction:** Adjust the color of the screen if you find it difficult to see some colors.
 - **Color inversion:** Reverse the display of colors from white text on a black background to black text on a white background.
 - **Color filter:** Adjust the screen colors if you have difficulty reading the text.
 - **Remove animations:** Remove certain screen effects if you are sensitive to motion.
 - **Reduce transparency and blur:** Reduce visual effects on dialogs and menus.
 - **Magnification:** Triple tap to zoom in and out.
 - **Bold font:** Enable to display text in bold.
 - **Font size:** Adjust the size of the font.



Hearing enhancements

You can configure Accessibility features to assist with audial aspects of the device.

- From  **Settings**, tap  **Accessibility** > **Hearing enhancements** and tap an option:
 - **Mute all sounds:** Turn off all notifications and audio for privacy.
 - **Mono audio:** Switch audio from stereo to mono when using one earphone.
 - **Left/right sound balance:** Use the sliders to adjust the left and right balance for connected audio and device speakers.



Interaction and dexterity

You can configure Accessibility features to assist with limited dexterity when interacting with your device.

- From  **Settings**, tap  **Accessibility** > **Interaction and dexterity** and tap an option:
 - **Universal gestures:** Control your device with your customized gestures.
 - **Touch and hold delay:** Select a time interval for this action.
 - **Tap duration:** Set how long an interaction must be held to be recognized as a tap.
 - **Ignore repeated touches:** Set a time duration in which to ignore repeated touches.

Advanced settings

You can configure Accessibility features.

- From  **Settings**, tap  **Accessibility** > **Advanced settings** for the following options:
 - **Double press:** Set a shortcut when double pressing the Home button.
 - **Triple press:** Set a shortcut when triple pressing the Home button.
 - **Vibration watch:** The watch uses vibrations to communicate the time.
 - **Time to take action:** Choose how long to show messages that ask you to take action, but are visible only temporarily (like notifications).

Installed apps

You can install additional assistance services and apps for your device.

- From  **Settings**, tap  **Accessibility** > **Installed apps** for a list of installed services.



Security and privacy

You can secure your device and protect your data by setting a screen lock.

[Set a screen lock](#) | [Permission manager](#) | [Wrist detection](#) | [Location](#) | [Safety and emergency](#)



Set a screen lock

It is recommended that you secure your device using a screen lock.

1. From  **Settings**, tap  **Security and privacy** > **Lock type** to select a screen lock type:
 - **Pattern**: Create a pattern that you draw on the screen to unlock your device.
 - **PIN**: Set a PIN to use for unlocking the device when it is removed from your wrist and the screen is turned off.
 - **None**: Do not lock the screen.
2. Tap **Hide information** to keep notifications and personal information hidden on the watch screen.

Permission manager

Apps might access features of your watch that you permit them to (like the sensors, microphone, or location) when they are running in the background, not just when you are using the app. You can set your watch to notify you when this happens.

1. From  **Settings**, tap  **Security and privacy** > **Privacy** > **Permission manager**.
2. Tap a category, then tap an app to select which permissions you want to be notified about.



Wrist detection

When enabled the watch automatically detects when the watch is being worn. It is advisable to only turn this feature off if your watch has trouble detecting when it is on your wrist.

- From  **Settings**, tap  **Security and privacy** > **Wrist detection**.



Location

Some apps may require location services to be turned on for full functionality.

1. From  **Settings**, tap  **Location**.
2. Tap  to enable this feature.
3. Tap **App permissions** to review apps and features that have permission to access your location information.

Safety and emergency

Store emergency information in your watch and customize your safety settings.

1. From  **Settings**, tap  **Safety and emergency**.
2. Tap an option to customize:
 - **Medical info:** Enter your allergies, current medication, and other medical information you would like to be available in an emergency.
 - **Emergency contacts:** Designate your emergency contacts.
 - **Emergency SOS:** Send an SOS message to your emergency contacts when you press the Home button 5 times.
 - **Hard fall detection:** Automatically call an emergency contact when your watch detects a hard fall.
 - **Emergency sharing:** Send a message to your emergency contacts about your location.

Accounts and backup

Set up and manage your accounts.

[Samsung account](#) | [Google account](#) | [Google settings](#)

Samsung account

Sign in to your Samsung account to access exclusive Samsung content and make full use of Samsung apps.

- From  **Settings**, tap  **Accounts and backup** > **Samsung account** to add your account information.



TIP You can also access your Samsung account from the top of the settings menu.

Google account

Sign in to your Google Account to access your Google Cloud Storage, apps installed from your account, and make full use of your device's Android™ features.

- From  **Settings**, tap  **Accounts and backup** > **Google account** to add your account information.

Google settings

You can configure your device's Google settings. Available options depend on your Google Account.

- From Settings, tap  **Google**, and select an option to customize.

Other settings

Configure features on your device.

[Software update](#) | [Tips and tutorials](#) | [About watch](#)

Software update

Check for and install available software updates for your device. Options may vary by carrier.

- From  **Settings**, tap  **Software update** to check for available software updates.

Tips and tutorials



Discover tips and techniques as well as tutorials for your device.

- From  **Settings**, tap  **Tips and tutorials** to review tips on your smartphone, and tutorials on your watch.

 **TIP** To access the user manual from the  **Galaxy Wearable** app on your smartphone, tap  **Tips and user guide**.

About watch

Display information about the watch.

- From  **Settings**, tap  **About watch** to review information about your watch:
 - **Device info:** Display your device name and Bluetooth identifier.
 - **Watch phone number:** Display the phone number assigned to your watch (LTE model only).
 - **Model number:** Display your watch's model number.
 - **Serial number:** Display your watch's serial number.
 - **IMEI:** Display your watch's IMEI number.
 - **Status information:** Access device information about the watch.
 - **Legal information:** Access legal information related to the watch.

- **Software information:** Check your watch's software version and security status.
- **Battery information:** Check the watch's battery voltage and capacity.

Learn more

Videos

youtube.com/samsungcare

Samsung Care

samsung.com/us/support

Talk to an agent

Contact us on Facebook Messenger: m.me/samsungsupport

Find us on Facebook: facebook.com/samsungsupport

Follow us on X (formerly Twitter): x.com/samsungsupport

Legal information

READ THIS INFORMATION BEFORE USING YOUR MOBILE DEVICE.

Dispute Resolution Agreement - This Product is subject to a binding dispute resolution agreement between you and SAMSUNG ELECTRONICS AMERICA, INC. ("Samsung"). You can opt out of the agreement within 30 calendar days of the first consumer purchase by emailing optout@sea.samsung.com or calling 1-800-SAMSUNG (726-7864) and providing the applicable information.

The full Dispute Resolution Agreement, Standard One-year Limited Warranty, End User License Agreement (EULA), and Health & Safety Information for your device are available online at <https://www.samsung.com/us/Legal/Gear-HSGuide>.

Restricting children's access to your mobile device

Your device is not a toy. Do not allow children to play with it because they could hurt themselves and others, or damage the device, or make calls that increase your device bill. Keep the device and all its parts and accessories out of the reach of small children.

Samsung Electronics America, Inc.

Address:

85 Challenger Road
Ridgefield Park
New Jersey 07660

Phone: 1-800-SAMSUNG (726-7864)

Internet: samsung.com

©2024 Samsung Electronics America, Inc. Samsung, Samsung Galaxy, and Samsung Health are all trademarks of Samsung Electronics Co., Ltd.

Other marks are the property of their respective owners.



Some multimedia (audio/video) files contain Digital Rights Management (DRM) technology to verify you have the right to use the files. Preloaded apps on your device may not be compatible with DRM-protected files.

Screen images are simulated. Appearance of device may vary.

Descriptions are based on the device's default settings. Some content may differ depending on carrier, model, or software.

The actual available capacity of the internal storage is less than the specified capacity because the operating system and default applications occupy part of the memory. The available capacity may change when you upgrade the device.

Please check with your service provider to verify qualifying services/features.