

QDD-100GB-DCO-ZRP-AO

MSA and TAA Compliant 100GBase-ZR+ QSFP-DD Transceiver (SMF, Coherent, LC, DOM, Open ZR+)

Features:

- QSFP-DD MSA compliant
- Hot pluggable QSFP-DD footprint (Type 2A)
- Supports 100Gbps Payload (OpenZR+)
- Duplex LC connector
- Tunable C-band Transmitter
- Coherent Receivers
- O-FEC (15%) with 11.6dB Net Coding Gain
- Power Dissipation < 16.5W
- Single +3.3V Power Supply
- 100GAUI-2 (2x 26.5625GBd PAM4) Serial Electrical Interface, RS-FEC (544/514)
- CAUI-4 (4x 25.78125Gbps NRZ) Serial Electrical Interface, RS-FEC (544/528)/No FEC
- Operating case temperature: -5°C to 80°C
- RoHS Compliant



Applications

- 100 Gigabit Ethernet

Product Description

This MSA compliant QSFP-DD transceiver provides 100GBase-ZR Open ZR+ throughput over Single-mode fiber (SMF) using a coherent wavelength and using an LC connector. It is built to MSA standards and is uniquely serialized and data-traffic and application tested to ensure that they will integrate into your network seamlessly. Digital optical monitoring (DOM) support is also present to allow access to real-time operating parameters. This transceiver is Trade Agreements Act (TAA) compliant. We stand behind the quality of our products and proudly offer a limited lifetime warranty.

AddOn's transceivers are RoHS compliant and lead-free.

TAA refers to the Trade Agreements Act (19 U.S.C. & 2501-2581), which is intended to foster fair and open international trade. TAA requires that the U.S. Government may acquire only "U.S. – made or designated country end products."



Regulatory Compliance

- ESD to the Electrical PINs: compatible with MIL-STD-883E Method 3015.4
- ESD to the LC Receptacle: compatible with IEC 61000-4-3
- EMI/EMC compatible with FCC Part 15 Subpart B Rules, EN55022:2010
- Laser Eye Safety compliant with FDA 21CFR, EN60950-1& EN (IEC) 60825-1,2
- RoHS compliant with EU RoHS 2.0 directive 2015/863/EU

Absolute Maximum Ratings

Parameter	Symbol	Min.	Typ.	Max.	Unit	Notes
Power Supply Voltage	VCC	3.218	3.3	3.465	V	
Storage Temperature	Ts	-40		85	°C	
Case Operating Temperature	Top	-5		80	°C	
Relative Humidity (non-condensing)	RH			85	%	
Optical Receiver Overload				4	dBm	1
Supported Host Signal Types			103.125		Gbps	2
Line Baud Rate			30.07		GBd	3

Notes:

1. The optical input to the receiver should not exceed this value. Transmitters must never be directly connected to receivers before ensuring that proper optical attenuation is used
2. As per IEEE 802.3-2012
3. 100G DP-QPSK, O-FEC

Electrical Characteristics

Parameter	Symbol	Min.	Typ.	Max.	Unit	Notes
Power Supply Voltage	Vcc	3.218	3.3	3.465	V	
Power Supply Current	Icc			6	A	
Power Consumption	PD			16.5	W	
Power Consumption	PD			1.5	W	1

Notes:

1. Low power mode

Optical Characteristics

Parameter	Symbol	Minimum	Typical	Maximum	Unit	Notes
Transmitter						
Average Output Power	P _o	-6	-4.5	-2	dBm	1, 2
Laser Linewidth				300	kHz	
Transmitter VOA Dynamic Range		10			dB	3
Output Power Stability		-1		1	dB	
In-Band OSNR		35			dB/0.1nm	
Out-of-Band OSNR		35			dB/0.1nm	
Frequency Range		191.275		196.125	THz	4
Centre Frequency		$\nu_T - 1.5$	ν_T	$\nu_T + 1.5$	GHz	5
Channel Spacing		6.25			GHz	
Centre Wavelength Range	T λ	1528.58		1567.34	nm	
Centre Wavelength	T λ	$\lambda_T - 15$	λ_T	$\lambda_T + 15$	pm	
Receiver						
Receiver Operating Wavelength	R λ	1528.58		1567.34	nm	
Receiver Sensitivity	S			-32	dBm	6
Receiver Overload	P _{OL}	4			dBm	7
Receiver Input Power Range		-20		4	dBm	8
Extended Receiver Input Power Range		-25		4	dBm	9
Acquisition Range		-3.6		3.6	GHz	10
Upstream Tx Linewidth				1000	kHz	
OSNR Tolerance			14	15.5	dB	11
Crosstalk Tolerance				17	dB	12
Chromatic Dispersion Tolerance				5000	ps/nm	13

Notes:

1. Output power coupled into a 9/125 μm single mode fibre
2. The output power is settable in steps of 0.1 dB within the specified wavelength range
3. With Tx VOA attenuation set to minimum
4. Per ITU-T G.694.1 DWDM grid definition
5. Applies also to LO
6. Minimum input power needed to achieve post-FEC BER $\leq 10^{-15}$, 100G DP-QPSK, OSNR > 35dB
7. The optical input to the receiver should not exceed this value. Transmitters must never be directly connected to receivers before ensuring that proper optical attenuation is used
8. An input power in this range guarantees optimum OSNR performance
9. With ≤ 1 dB OSNR tolerance degradation
10. Frequency offset between received carrier and LO

11. At optimum input power range
12. Ratio of accumulated crosstalk channels to signal power
13. Less than 0.5dB receiver sensitivity penalty compared to OSNR>35dB

Pin Descriptions

Pin	Logic	Symbol	Name/Descriptions	Plug Sequence
1		GND	Ground	1B
2	CML-I	Tx2n	Transmitter Inverted Data Input	3B
3	CML-I	Tx2p	Transmitter Non-Inverted Data Input	3B
4		GND	Ground	1B
5	CML-I	Tx4n	Transmitter Inverted Data Input	3B
6	CML-I	Tx4p	Transmitter Non-Inverted Data Input	3B
7		GND	Ground	1B
8	LVTTL-I	ModSelL	Module Select	3B
9	LVTTL-I	ResetL	Module Reset	3B
10		VccRx	+3.3V Power Supply Receiver	2B
11	LVC MOS-I/O	SCL	2-wire serial interface clock	3B
12	LVC MOS-I/O	SDA	2-wire serial interface data	3B
13		GND	Ground	1B
14	CML-O	Rx3p	Receiver Non-Inverted Data Output	3B
15	CML-O	Rx3n	Receiver Inverted Data Output	3B
16		Ground	1B	
17	CML-O	Rx1p	Receiver Non-Inverted Data Output	3B
18	CML-O	Rx1n	Receiver Inverted Data Output	3B
19		GND	Ground	1B
20		GND	Ground	1B
21	CML-O	Rx2n	Receiver Inverted Data Output	3B
22	CML-O	Rx2p	Receiver Non-Inverted Data Output	3B
23		GND	Ground	1B
24	CML-O	Rx4n	Receiver Inverted Data Output	3B
25	CML-O	Rx4p	Receiver Non-Inverted Data Output	3B
26		GND	Ground	1B
27	LVTTL-O	ModPrsL	Module Present	3B
28	LVTTL-O	IntL	Interrupt	3B
29		VccTx	+3.3V Power supply transmitter	2B
30		Vcc1	+3.3V Power supply	2B
31	LVTTL-I	InitMode	Initialization mode; In legacy QSFP applications, the InitMode pad is called LPMODE	3B
32		GND	Ground	1B
33	CML-I	Tx3p	Transmitter Non-Inverted Data Input	3B

34	CML-I	Tx3n	Transmitter Inverted Data Input	3B
35		GND	Ground	1B
36	CML-I	Tx1p	Transmitter Non-Inverted Data Input	3B
37	CML-I	Tx1n	Transmitter Inverted Data Input	3B
38		GND	Ground	1B
39		GND	Ground	1A
40	CML-I	Tx6n	Transmitter Inverted Data Input	3A
41	CML-I	Tx6p	Transmitter Non-Inverted Data Input	3A
42		GND	Ground	1A
43	CML-I	Tx8n	Transmitter Inverted Data Input	3A
44	CML-I	Tx8p	Transmitter Non-Inverted Data Input	3A
45		GND	Ground	1A
46		Reserved	For future use	3A
47		VS1	Module Vendor Specific 1	3A
48		VccRx1	3.3V Power Supply	2A
49		VS2	Module Vendor Specific 2	3A
50		VS3	Module Vendor Specific 3	3A
51		GND	Ground	1A
52	CML-O	Rx7p	Receiver Non-Inverted Data Output	3A
53	CML-O	Rx7n	Receiver Inverted Data Output	3A
54		GND	Ground	1A
55	CML-O	Rx5p	Receiver Non-Inverted Data Output	3A
56	CML-O	Rx5n	Receiver Inverted Data Output	3A
57		GND	Ground	1A
58		GND	Ground	1A
59	CML-O	Rx6n	Receiver Inverted Data Output	3A
60	CML-O	Rx6p	Receiver Non-Inverted Data Output	3A
61		GND	Ground	1A
62	CML-O	Rx8n	Receiver Inverted Data Output	3A
63	CML-O	Rx8p	Receiver Non-Inverted Data Output	3A
67		GND	Ground	1A
68		NC	No Connect	3A
69		Reserved	For future use	3A
70		VccTx1	3.3V Power Supply	2A
71		Vcc2	3.3V Power Supply	2A
72		Reserved	For Future Use	3A
73		GND	Ground	1A
74	CML-I	Tx7p	Transmitter Non-Inverted Data Input	3A
75	CML-I	Tx7n	Transmitter Inverted Data Input	3A
76		GND	Ground	1A

Electrical Pad Layout

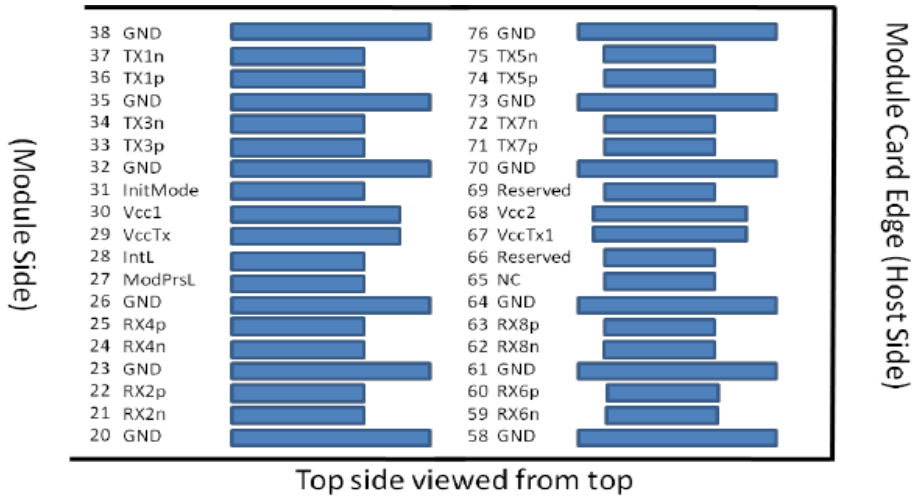

Top side viewed from top

Legacy QSFP28 Pads Additional QSFP-DD Pads

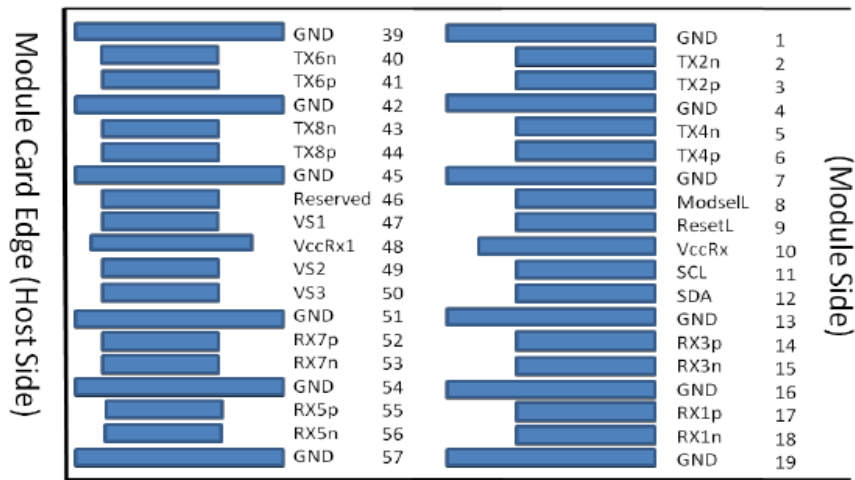

Bottom side viewed from bottom

Additional QSFP-DD Pads Legacy QSFP28 Pads

Recommended Power Supply Filter

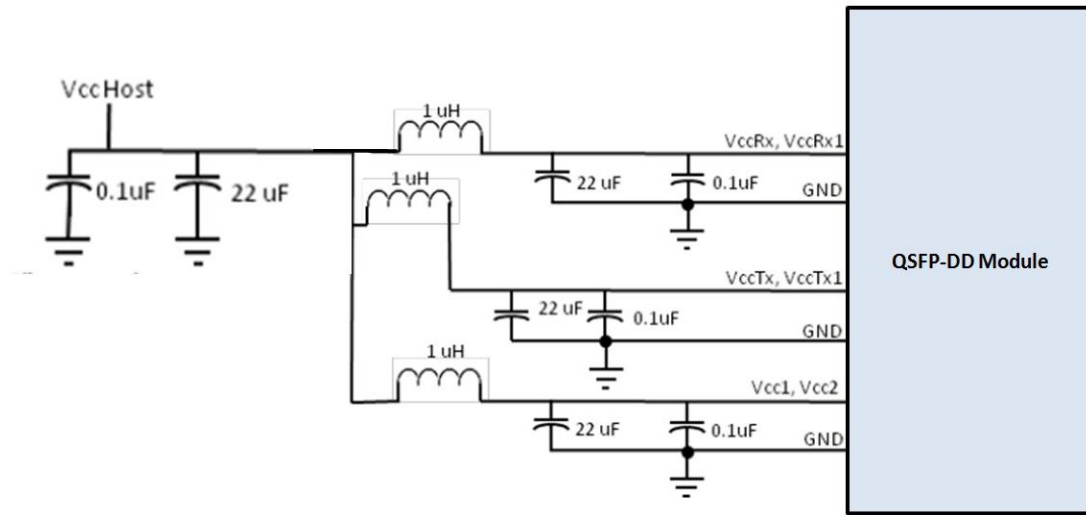

Mechanical Specifications

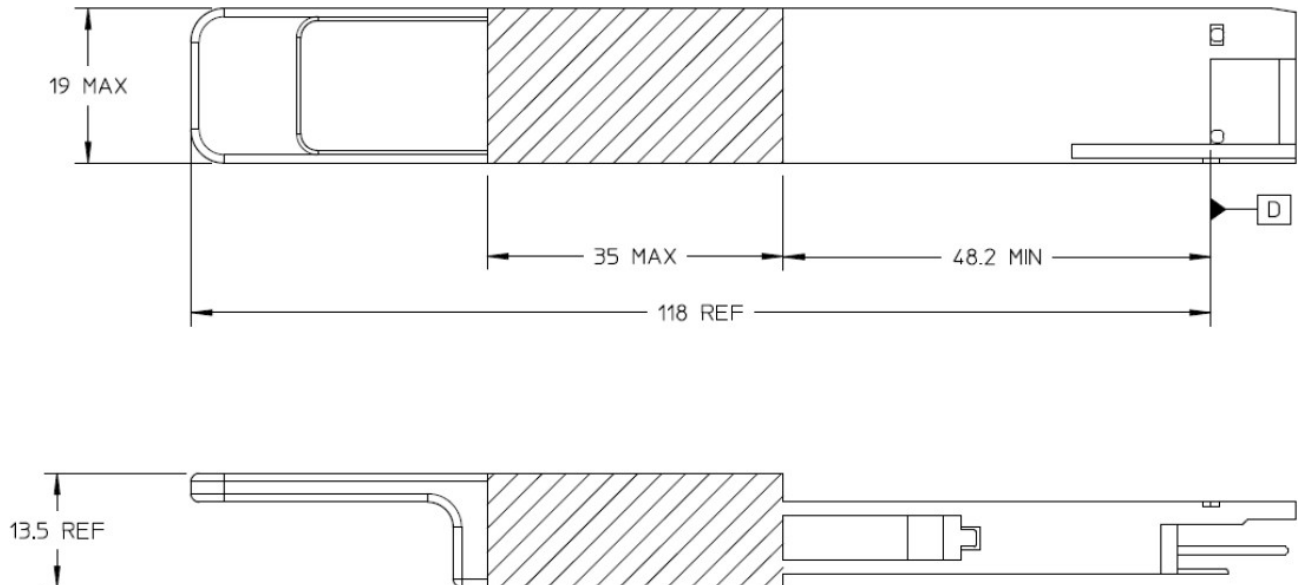

About AddOn Networks

In 1999, AddOn Networks entered the market with a single product. Our founders fulfilled a severe shortage for compatible, cost-effective optical transceivers that compete at the same performance levels as leading OEM manufacturers. Adhering to the idea of redefining service and product quality not previously had in the fiber optic networking industry, AddOn invested resources in solution design, production, fulfillment, and global support.

Combining one of the most extensive and stringent testing processes in the industry, an exceptional free tech support center, and a consistent roll-out of innovative technologies, AddOn has continually set industry standards of quality and reliability throughout its history.

Reliability is the cornerstone of any optical fiber network and is engrained in AddOn's DNA. It has played a key role in nurturing the long-term relationships developed over the years with customers. AddOn remains committed to exceeding industry standards with certifications from ranging from NEBS Level 3 to ISO 9001:2005 with every new development while maintaining the signature reliability of its products.

U.S. Headquarters

Email: sales@addonnetworks.com

Telephone: +1 877.292.1701

Fax: 949.266.9273

Europe Headquarters

Email: salesupportemea@addonnetworks.com

Telephone: +44 1285 842070