

# QuickSpecs

## HPE ContexNet SBC Global Traffic Manager

### Overview

#### HPE ContexNet SBC Global Traffic Manager

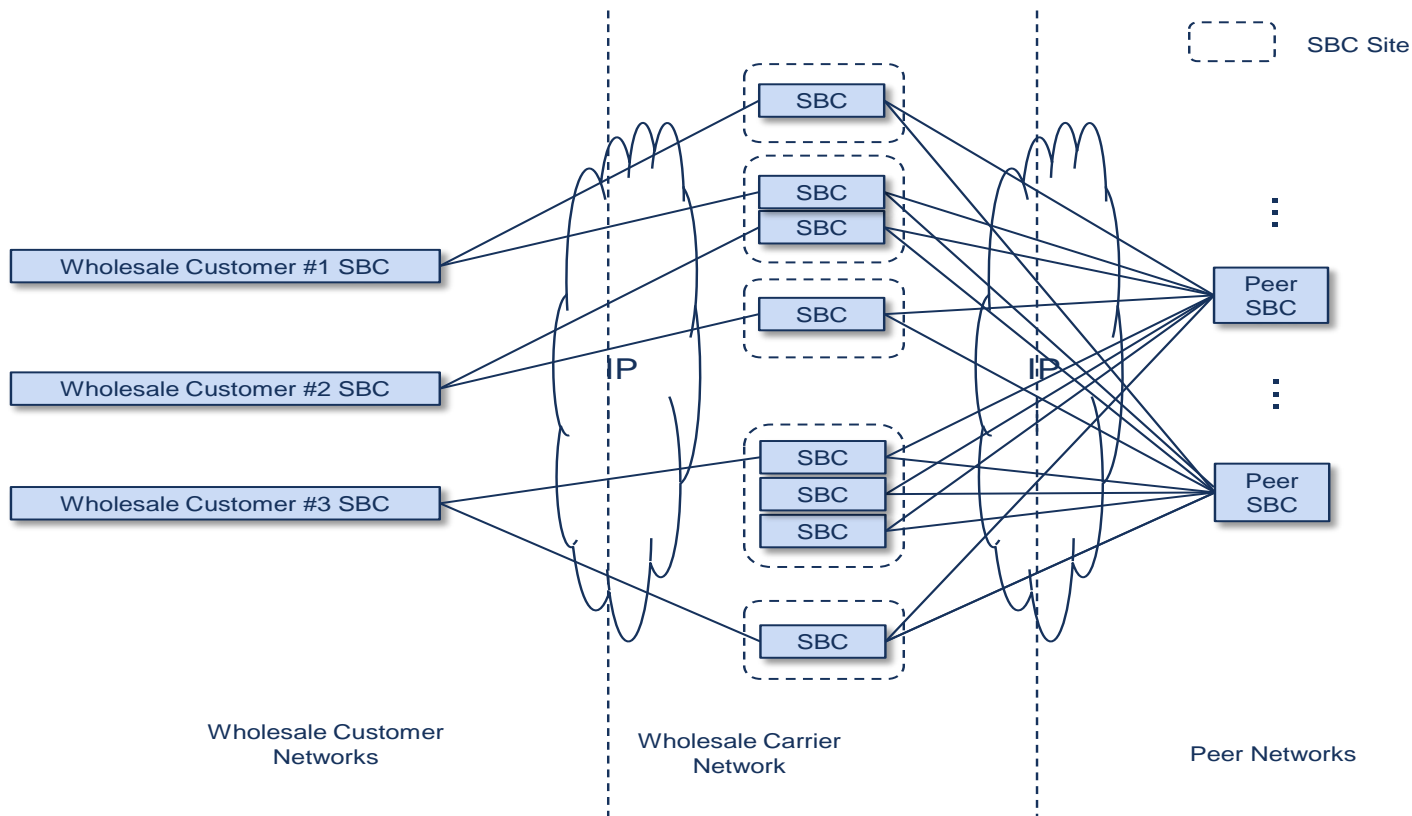

HPE ContexNet's SBC Global Traffic Manager is a load balancing solution for a wholesale VoIP service providers that allow other VoIP service providers use their network to peer with other VoIP service providers.

A generic wholesale solution (without ContexNet) is illustrated in the figure above. The wholesale customer's Session Border Controllers (SBCs), located at various sites, are connected to Wholesale Customers via IP networks. Each wholesale customer is assigned two SBCs, one acting as primary and the other as secondary. Health checking and failover are the responsibility of the customer and, often, when a failure is detected, instead of failing over to the secondary SBC, customers choose to fail over to an alternate provider – resulting in lost revenue to the wholesale carrier. Furthermore, as each wholesale customer can only be supported by a single SBC, there are severe limitations on the scale of the service to any single customer.

The ContexNet SBC Global Traffic Manager solution addresses these issues by introducing a distributed SBC load balancer to which wholesale customers connect. The ContexNet SBC Load Balancer, a carrier class, fully redundant solution, presents virtual IP addresses to wholesale customers and load balances calls amongst a set of SBCs, per policy configured by the operator. Both physical and virtual SBCs are supported.

The ContexNet solution for SBC load balancing is shown in the figure below.

## Overview

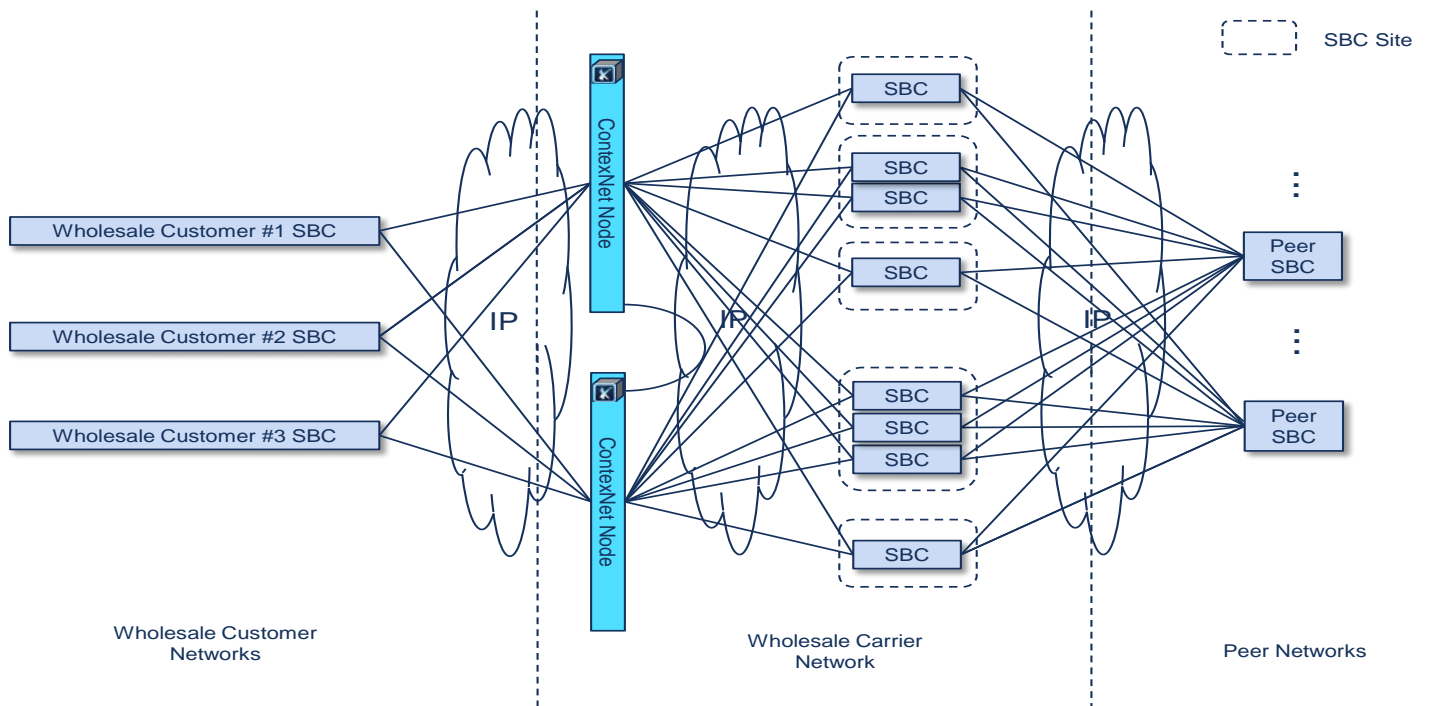

ContexNet nodes, comprising **dual, redundant** Grid Servers are deployed in multiple sites. Each ContexNet node can access all SBCs, which may be collocated or at another site. Each ContexNet node presents Virtual IP addresses to wholesale customers.

ContexNet implements load balancing based on per-customer policy. This policy specifies the SBCs amongst which calls will be load balanced for each customer, as well as the relative weights of each SBC, representing their relative capacity. The load balancing scheme also enables setting priorities per SBC, allowing for preference of SBCs per customer.

---

## HPE Licenses

**Item**

HPE ContexNet SBC Global Traffic Manager 10K Calls 1yr 24x7 Support Perpetual E-RTU

**SKU**

P9U43AAE

**NOTE:** Product SKUs come bundled with 1 year, 24x7 support.

## Standard Features

### HPE ContexNet Benefits **Scaling SBCs**

ContexNet SBC GTM scales SBCs with automated, fine grained load balancing of calls to multiple vendors' SBCs located in diverse locations according to per wholesale customer policy

### **Ease of Management**

ContexNet SBC GTM eases the configuration and management of SBCs and wholesale customers. Adding a customer is effortless and quick as is adding or reducing a customer's capacity. Similarly addition or removal of SBCs is fast and simple.

### **Virtualization**

ContexNet SBC GTM allows for a clear path to virtualization by enabling dynamic addition and removal of SBCs, physical SBCs can easily be replaced by virtual SBCs that are instantiated and de-instantiated elastically according to usage demand.

### **High Availability**

ContexNet SBC GTM ensures the high availability of SBCs by performing various health checks on the SBCs and ensuring they are available and have spare capacity before sending new calls to them. **SBC failover is automated and quick.**

### **Revenue Protection**

**Customers do not move to another operator when an SBC fails as they do in the current solution. In fact they usually don't know it even happened.**

### Key Product Features **Load Balancing**

- Wholesale customers are each assigned Virtual IP Addresses
  - Use as destination addresses on SIP calls
- Load balancing of SIP calls based on per-customer VIP policy
  - Specifies the SBCs amongst which calls will be load balanced for each VIP
  - Relative weights of each SBC, representing their relative capacity.
  - Priorities per SBC, allowing for preference of SBCs per customer.
- ContexNet load balances individual calls amongst the SBCs
  - Per the VIP policy and SBC health.
  - All packets associated with a specific call Id are sent to the same SBC.

### **Customer VIPs**

- 
- Each VIP is represented by a name and an IP address.
- For each Virtual IP address, a whitelist of wholesale customer SBC IP addresses is configured
  - Only packets from those source IP addresses are accepted
  - Other packets are dropped without a response
- Constraints on each wholesale customer VIP:
  - Simultaneous calls
  - INVITE rate per second
  - If any constraint exceeded, INVITE is dropped and error response code is sent to customer
- Load Balancing Policy:
  - Priority and weight configured per SBC in policy
  - Calls load balanced amongst the highest priority (lowest

## Standard Features

- priority value) SBCs that are currently available
  - Calls distributed amongst SBCs according to weights
  - 
  - **SBCs Configuration**
    - Each SBC is configured with:
      - Name, IP address etc.
      - Capacity in terms of calls, calls per second
      - Health checks / health scripts
  - **SIP Proxy**
    - Stateless SIP proxy per RFC 3261 between the customer and the wholesale operator's SBCs.
    - NATs packets from Wholesale Customer:
      - Sets the egress source IP address to ingress destination IP address
      - Sets egress destination IP address to the selected SBC address.
    - Rewrites the SIP Request URI with the destination SBC address.
    - Inserts a Via header with its IP into SIP requests and removes its Via header from SIP responses.
    - Inserts a record-route with its IP address in INVITE messages.
    - Changes the To: header from the ContexNet IP address to the SBC IP address in SIP requests
    - Changes the To: header SBC IP address to the ContexNet IP address in SIP responses
  - **Miscellaneous**
    - Responses to Customer Health Checks
      - ContexNet responds to health checks from the wholesale customer carriers
      - According to aggregate status of SBCs
    - INVITE Re-Balancing
      - ContexNet resends failed INVITE message to another SBC based on the load balancing policy
      - If the INVITE packet sent to the second SBC also results failure, call fails and response sent to customer
  - **Element and network management**
    - CLI and GUI for comprehensive configuration and monitoring
    - Software installation, upgrade, and rollback
    - SNMP
    - Extensive logging
-

## Service and Support and Warranty Information

### Software Support

**ContexNet** is available with four choices for support:

Support Level	Details
9 x 5 Standard	Hewlett Packard Enterprise will respond within 2 hours to critical cases received weekdays from 8am-5pm (local time), excluding Hewlett Packard Enterprise holidays. Cases received outside that window will be replied to on the next Hewlett Packard Enterprise business day.
24 X 7 Standard	Hewlett Packard Enterprise will respond to received critical cases within 1 hour. This coverage applies 24 hours per day, 365 days per year.
24 x 7 Enhanced	Hewlett Packard Enterprise will respond to received critical cases within 30 minutes. Also, quicker response and resolution times as compared to standard support. This coverage applies 24 hours per day, 365 days per year.
24 x 7 Telecom Critical Support	For TCS support, Hewlett Packard Enterprise will respond to received critical cases within 15 minutes. Also, quicker response, resolution and fix times as compared to standard support. This level of coverage is geared towards the critical support and quick turnaround mandated by telecom providers, carriers and cable operators. This coverage applies 24 hours per day, 365 days per year.

HPE ContexNet products are supported by HPE Communications Solutions Business (CSB) group, providing troubleshooting, advice and assistance. The ContexNet dedicated support is provided through a virtual team located around the world, available 24x7 (depending on the service level purchased). The ContexNet Support team is highly trained in areas of OpenStack technology, network virtualization, converged infrastructure, and complex solution interoperability.

Hewlett Packard Enterprise Worldwide Customer Service contact numbers are available at:

<http://www.hp.com/country/us/en/wwcontact.html>

## Related Options

### HPE ContexNet Professional Services

#### **HPE Professional Services for ContexNet**

ConteXtream (a Hewlett Packard Enterprise Company) has been helping customers deploy Software Defined Networking and Virtualized Network Functions solutions for years and our Professional Services teams have played a significant role in those successes. HPE Professional Services is a dedicated team of professional consultants available worldwide to accelerate and support SDN and NFV deployments in OpenStack cloud environments. These enterprise services are delivered by an experienced team of HPE cloud architects, technologists, and engineers with expertise in design, storage, networking, security, database, scalability, high availability, and other OpenStack-based services.

Customers will benefit from HPE Professional Services for ContexNet in the following ways:

- Drive innovation and faster time to market/service delivery by enabling early adoption of SDN and NFV technologies
- Mitigate risk by ensuring network virtualization based projects are implemented with industry best practices
- Integrate development and operations by leveraging a best-practice implementation of ContexNet based on virtual compute platforms
- Empower developers and operations to come together for building and deploying physical and virtual network functions leveraging highly scalable, highly available services with network virtualization and SDN
- Achieve operational excellence by leveraging Hewlett Packard Enterprise experience in managing and supporting IT environments
- Impart product knowledge, industry expertise and extensive deployment experience in trainings to key stakeholders for faster deployment and successful operation of a complex virtual network environment.

---

## Technical Specifications

### Other product information

Additional information is available on HPE ContexNet web page, which is referenced at: <http://www8.hp.com/il/en/cloud/nfv-sdn.html>.

---

### Environment-friendly Products and Approach

### End-of-life Management and Recycling

Hewlett Packard Enterprise offers end-of-life Hewlett Packard Enterprise product return, trade-in, and recycling programs in many geographic areas. For trade-in information, please go to <http://www.hp.com/go/green>. To recycle your product, please go to: <http://www.hp.com/go/green> or contact your nearest Hewlett Packard Enterprise sales office. Products returned to Hewlett Packard Enterprise will be recycled, recovered or disposed of in a responsible manner.

The EU WEEE directive (2002/95/EC) requires manufacturers to provide treatment information for each product type for use by treatment facilities. This information (product disassembly instructions) is posted on the Hewlett Packard Enterprise web site at: <http://www.hp.com/go/green>. These instructions may be used by recyclers and other WEEE treatment facilities as well as Hewlett Packard Enterprise OEM customers who integrate and re-sell Hewlett Packard Enterprise equipment.

---

## Summary of Changes

Date	Version History	Action	Description of Change:
06-Jun-2016	Version 1	QS Creation	Document creation



**Sign up for updates**

© Copyright 2016 Hewlett Packard Enterprise Development LP. The information contained herein is subject to change without notice. The only warranties for Hewlett Packard Enterprise products and services are set forth in the express warranty statements accompanying such products and services. Nothing herein should be construed as constituting an additional warranty. Hewlett Packard Enterprise shall not be liable for technical or editorial errors or omissions contained herein.

The OpenStack word mark and the Square O Design, together or apart, are trademarks or registered trademarks of OpenStack Foundation in the United States and other countries, and are used with the OpenStack Foundation's permission."

Microsoft and Windows are US registered trademarks of Microsoft Corporation

VMware Trademark are US registered trademarks of VMware.

c05050462- 15573- Worldwide - V1 - 06-June-2016

