

SFP-25G-BX-U-AR-AO

Arista Networks® SFP-25G-BX-U-AR Compatible TAA Compliant 25GBase-BX SFP28 Transceiver (SMF, 1270nmTx/1330nmRx, 10km, LC, DOM)

Features

- SFF-8402 and SFF-8472 Compliance
- Simplex LC Connector
- Commercial Temperature 0 to 70 Celsius
- Single-mode Fiber
- Hot Pluggable
- Excellent ESD Protection
- Metal with Lower EMI
- RoHS Compliant and Lead Free



Applications

- 25GBase Ethernet
- Access and Enterprise

Product Description

This Arista Networks® SFP-25G-BX-U-AR compatible SFP28 transceiver provides 25GBase-BX throughput up to 10km over single-mode fiber (SMF) using a wavelength of 1270nmTx/1330nmRx via an LC connector. It is guaranteed to be 100% compatible with the equivalent Arista Networks® transceiver. This easy to install, hot swappable transceiver has been programmed, uniquely serialized and data-traffic and application tested to ensure that it will initialize and perform identically. Digital optical monitoring (DOM) support is also present to allow access to real-time operating parameters. This transceiver is Trade Agreements Act (TAA) compliant. We stand behind the quality of our products and proudly offer a limited lifetime warranty.

AddOn's transceivers are RoHS compliant and lead-free.

TAA refers to the Trade Agreements Act (19 U.S.C. & 2501-2581), which is intended to foster fair and open international trade. TAA requires that the U.S. Government may acquire only "U.S. – made or designated country end products."



Regulatory Compliance

- Electromagnetic Interference (EMI) compatible with standards: FCC Part 15 Class B, EN 55022:2010, Class B
- Electromagnetic susceptibility (EMS) compatible with standards: EN 55024:2010
- Laser Eye Safety compatible with Class I laser product FDA 21CFR 1040.10 and 1040.11 EN60950, EN (IEC) 60825-1,2
- RoHS compliant with EU RoHS 2.0 directive 2015/863/EU

Absolute Maximum Ratings

Parameter	Symbol	Min.	Max.	Unit
Maximum Supply Voltage	V _{CC}	-0.5	3.6	V
Storage Temperature	T _S	-40	85	°C
Operating Case Temperature	T _c	0	70	°C
Operating Humidity (non-condensing)	RH	5	95	%
Receiver Power	R _{MAX}		-12	dBm
Maximum Bitrate	B _{max}		28	Gbps

Electrical Characteristics (TOP=25°C, V_{CC}=3.3Volts)

Parameter	Symbol	Min.	Typ.	Max.	Unit	Notes
Power Supply Voltage	V _{CC}	3.135	3.30	3.465	V	
Power Supply Current @ 3.3V	I _{CC}			350	mA	
Power Consumption	P _{DISS}			1.5	W	
Transmitter						
Differential data input swing	V _{in,pp}	180		700	mV	
Transmitter Enable Voltage	V _{EN}	-0.3		0.8	V	
Transmitter Disable Voltage	V _D	2.0		V _{CC} +0.3	V	
Receiver						
Differential data output swing	V _{out,pp}	450		1050	mV	
LOS Low Voltage	V _{Lout}			0.4	V	
LOS High Voltage	V _{Hout}	2.0			V	

Optical Characteristics

Parameter	Symbol	Min.	Typ.	Max.	Unit	Notes
Transmitter						
Support Data Rate				28	Gbps	
Peak Wavelength	λ_p	1260	1270	1280	nm	
Spectral Width (-20dB)				1	nm	
Side Mode Suppression Ratio	SMSR	30			dB	
Average Optical Output Power	P _o	-5		2	dBm	
Optical Extinction Ratio	ER	3.5			dB	
Transmitter and Dispersion Penalty	TDP			3	dB	
Output Power with Transmitter Disabled	P _{off}			-30	dBm	
Optical Return Loss Tolerance				-12	dB	
Output Eye Diagram	Compliant with IEEE 802.3					1
Receiver						
Support data rate				28	Gbps	
Operate Wavelength		1320	1330	1340	nm	
Receiver Sensitivity @25Gbps	Sen			-12	dBm	2
Saturation	P _{sat}	2			dBm	2
LOS Asserted	T _{loss_on}	-30			dBm	High level: Alarm
LOS De-Asserted	T _{loss_off}			-13	dBm	
LOS Hysteresis	T _{loss_Hs}	0.5		5.0	dB	

Notes:

1. At least 1000 waveforms acquired, with minimum 5% margin against 802.3 mask
2. Test at 25.78125Gb/s, PRBS 2³¹-1, BER of 5E-5, NRZ and including back to back

Pin Descriptions

Pin	Symbol	Name/Descriptions	Ref.
1	VeeT	Transmitter Ground	
2	TX Fault	Transmitter Fault Indication	1
3	TX Disable	Transmitter Disable	2, Module disables on high or open
4	SDA	2-wire Serial Interface Data Line (Same as MOD-DEF2 in INF-8074i)	
5	SCL	2 Wire Serial Interface Data Line (Same as MOD-DEF1 as defined in the INF-8074i)	
6	MOD-ABS	Module Absent, Connected to VeeT or VeeR in the module.	3
7	RS0	SFP+ RX Rate Select, optional	Rate Select 0, Not used. 9
8	LOS	Loss of Signal	4
9	RS1	SFP+ TX Rate Select, optional	Rate Select 1, Not used. 9
10	VeeR	Receiver Ground	5
11	VeeR	Receiver Ground	5
12	RD-	Inv. Received Data Out	6
13	RD+	Received Data Out	6
14	VeeR	Receiver Ground	5
15	VccR	Receiver Power	7, 3.3V 5%
16	VccT	Transmitter Power	7, 3.3V 5%
17	VeeT	Transmitter Ground	5
18	TD+	Transmit Data In	8
19	TD-	Inv. Transmit Data In	8
20	VeeT	Transmitter Ground	5

Notes:

Plug Seq.: Pin engagement sequence during hot plugging.

- TX Fault is an open collector/drain output, which should be pulled up with a 4.7K–10KΩ resistor on the host board. Pull up voltage between 2.0V and VccT +0.3V. When high, output indicates a laser fault of some kind. Low indicates normal operation. In the low state, the output will be pulled to < 0.4V.
- TX disable is an input that is used to shut down the transmitter optical output. It is pulled up within the module with a 4.7–10 KΩ resistor. Its states are:
 Low (-0.3–0.8V): Transmitter on (>0.8, < 2.0V): Undefined
 High (2.0–VccT+0.3V): Transmitter Disabled Open: Transmitter Disabled
- Mod-ABS shall be pulled up with a 4.7K–10KΩ resistor on the host board. The pull-up voltage shall VccT or VccR.
- LOS (Loss of Signal) is an open collector/ drain output, which should be pulled up with a 4.7K–10KΩ resistor. Pull up voltage between 2.0V and VccR+0.3V. When high, this output indicates the received optical power is below the worst-case receiver sensitivity (as defined by the standard in use). Low

indicates normal operation. In the low state, the output will be pulled to < 0.4V.

5. VeeR and VeeT may be internally connected within the SFP module.
6. RD-/+ : These are the differential receiver outputs. They are AC coupled 100Ω differential lines which should be terminated with 100Ω (differential) at the user SERDES. The AC coupling is done inside the module and is thus not required on the host board.
7. VccR and VccT are the receiver and transmitter power supplies. They are defined as 3.3V 5% at the SFP connector pin. Maximum supply current is 300mA. Recommended host board power supply filtering is shown below. Inductors with DC resistance of less than 1Ω should be used in order to maintain the required voltage at the SFP input pin with 3.3V supply voltage.
When the recommended supply filtering network is used, hot plugging of the SFP transceiver module will result in an inrush current of no more than 30 mA greater than the steady state value. VccR and VccT may be internally connected within the SFP transceiver module.
8. TD-/+ : These are the differential transmitter inputs. They are AC -coupled, differential lines with 100Ω differential termination inside the module. The AC coupling is done inside the module and is thus not required on the host board.
9. Internally pulled down per SFF-8431 Rev 4.1.

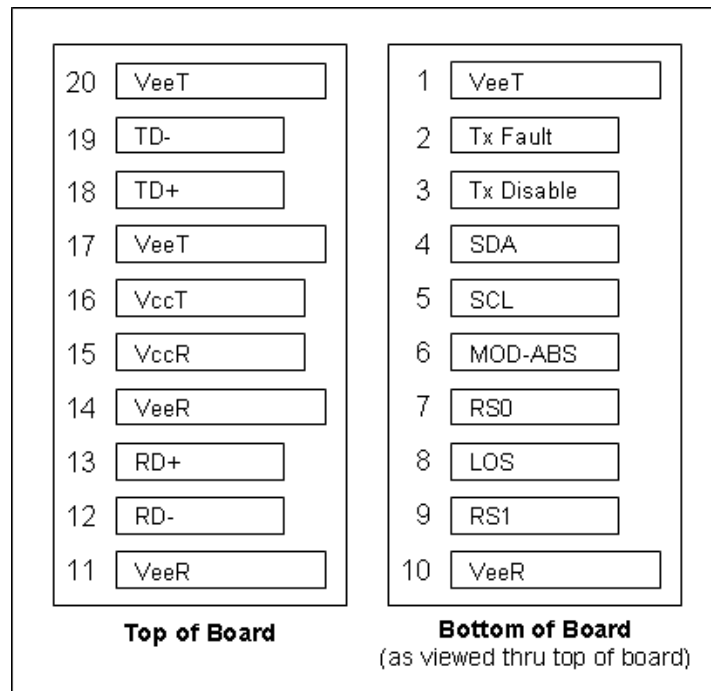

Pin-out of connector Block on Host board

Recommended Circuit Schematic

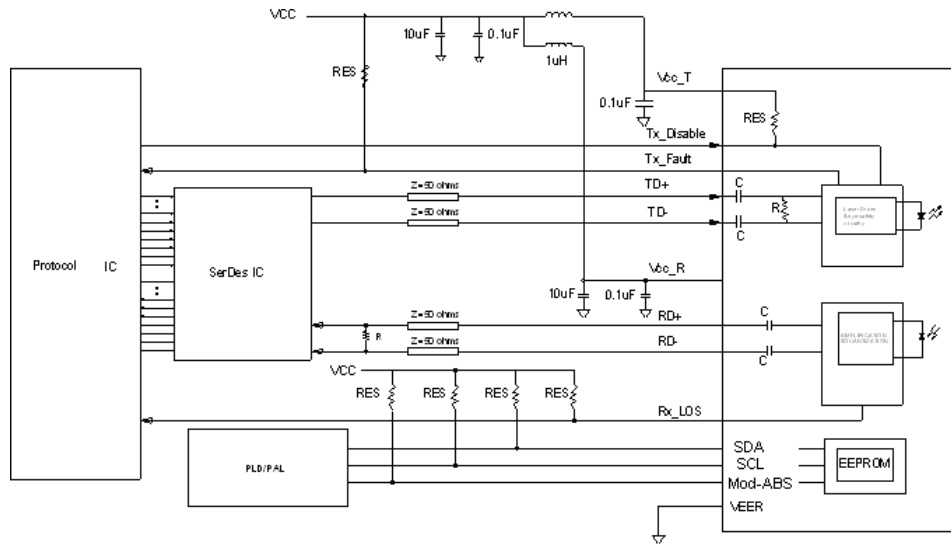

NOTE: 4.7K ohms < RES < 10K ohms

Digital Diagnostic Functions

Digital diagnostics monitoring function is available on this module. A 2-wire serial interface provides user to contact with module. It is compliant to SFF-8472 Rev10.2 with internal calibration mode.

Parameter	Symbol	Min.	Max.	Unit	Notes
Temperature monitor absolute error	DMI_Temp	-3	+3		
Supply voltage monitor absolute error	DMI_VCC	-3%	+3%	V	
TX power monitor absolute error	DMI_RX	-3	+3	dB	
RX power monitor absolute error	DMI_RX	-3	+3	dB	
Bias current monitor	DMI_Ibias	-10%	+10%	mA	

Mechanical Specifications

Small Form Factor Pluggable (SFP) transceivers are compatible with the dimensions defined by the SFP Multi-Sourcing Agreement (MSA).

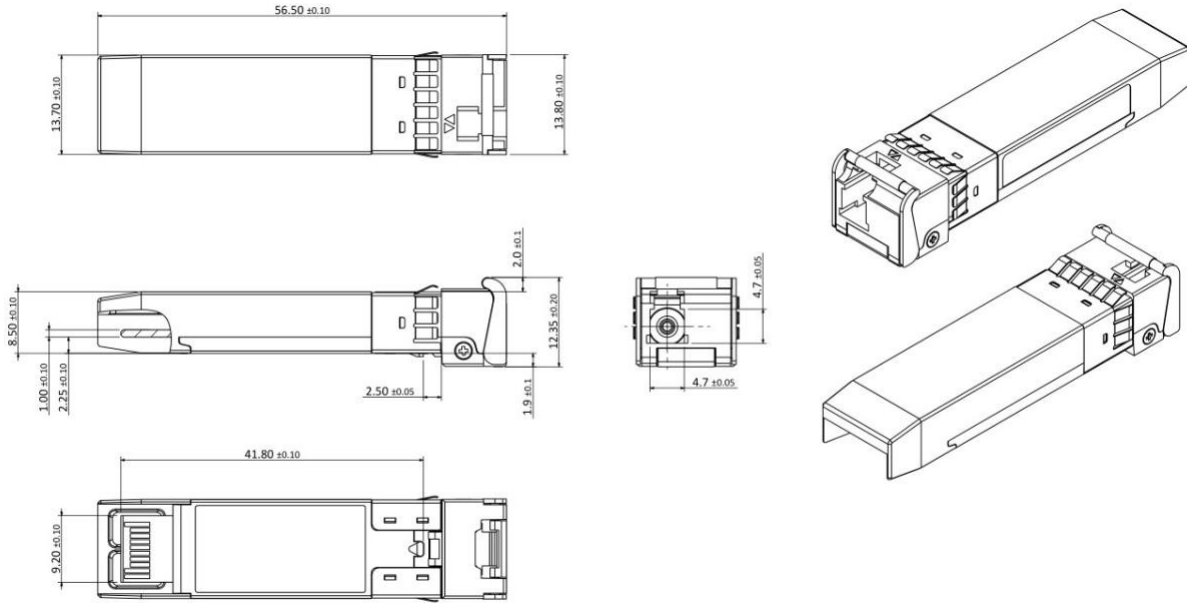

About AddOn Networks

In 1999, AddOn Networks entered the market with a single product. Our founders fulfilled a severe shortage for compatible, cost-effective optical transceivers that compete at the same performance levels as leading OEM manufacturers. Adhering to the idea of redefining service and product quality not previously had in the fiber optic networking industry, AddOn invested resources in solution design, production, fulfillment, and global support.

Combining one of the most extensive and stringent testing processes in the industry, an exceptional free tech support center, and a consistent roll-out of innovative technologies, AddOn has continually set industry standards of quality and reliability throughout its history.

Reliability is the cornerstone of any optical fiber network and is engrained in AddOn's DNA. It has played a key role in nurturing the long-term relationships developed over the years with customers. AddOn remains committed to exceeding industry standards with certifications from ranging from NEBS Level 3 to ISO 9001:2005 with every new development while maintaining the signature reliability of its products.

U.S. Headquarters

Email: sales@addonnetworks.com

Telephone: +1 877.292.1701

Fax: 949.266.9273

Europe Headquarters

Email: salesupportemea@addonnetworks.com

Telephone: +44 1285 842070