

HP Scanjet 7800

Setup and Support Guide



Copyright and license

© 2006 Copyright Hewlett-Packard Development Company, L.P.

Reproduction, adaptation or translation without prior written permission is prohibited, except as allowed under the copyright laws.

The information contained herein is subject to change without notice.

The only warranties for HP products and services are set forth in the express warranty statements accompanying such products and services. Nothing herein should be construed as constituting an additional warranty. HP shall not be liable for technical or editorial errors or omissions contained herein.

Trademark credits

ENERGY STAR is a U.S. registered service mark of the United States Environmental Protection Agency.

Microsoft and Windows are registered trademarks of Microsoft Corporation.

Contents

1	How to get started	2
	Step 1. Check the box contents	2
	Step 2. Install the software	3
	Step 3. Connect the power supply	3
	Step 4. Connect the USB cable	4
	Step 5. Prepare the scanner for use	5
	Step 6. Test the installation	6
	Scanning software CDs	6
	Power Save mode or Instant Lamp Warm-up mode	8
2	How to use the scanner buttons and card slot	9
	Scanner buttons	9
	Card slot	10
3	Special features	11
4	How to set up and use profiles	12
	Set up a profile with HP Smart Document Scan Software	12
	Assign profile numbers with the Button Settings Utility	13
	Modify a profile with HP Smart Document Scan Software	13
	Import and export profiles	13
	Customizable profile labels	15
5	Where to get additional information	16
	HP Scanjet 7800 User Guide	16
	HP Smart Document Scan Software help	16
	Button Settings Utility help	17
6	Care and maintenance	18
7	Troubleshooting	19
	Installation dialog box does not display	19
	Scanner error codes	19
	Other sources for help	19
	Scanner does not work after installation	19
8	Product support	22
	Accessibility	22
	HP Scanjet Web site	22
	Support process	22
9	Regulatory information and product specifications	24
	Scanner specifications	24
	Environmental specifications	24
	Regulatory information	25
	Recycle and restricted material information	25
	Disposal of Waste Equipment by Users in Private Households in the European Union	25
10	Hewlett-Packard limited warranty statement	27
	Regions	28
A	Scanner error codes	32

1 How to get started

Follow these steps to set up the scanner:

- Step 1. Check the box contents
- Step 2. Install the software
- Step 3. Connect the power supply
- Step 4. Connect the USB cable
- Step 5. Prepare the scanner for use
- Step 6. Test the installation
- Scanning software CDs
- Power Save mode or Instant Lamp Warm-up mode

Step 1. Check the box contents

Unpack the scanner hardware. Be sure to remove any shipping tape.

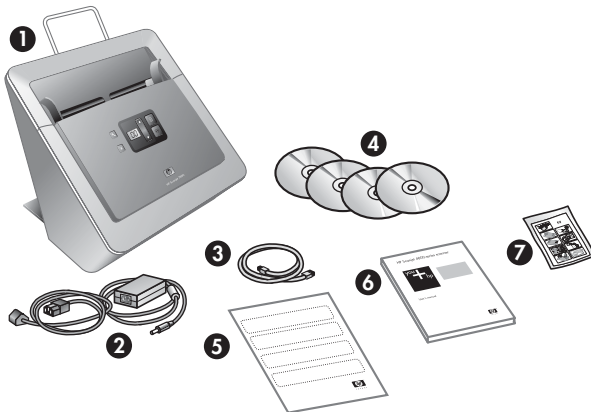

1	HP Scanjet 7800 scanner
2	Power supply
3	USB cable
4	Scanning software CDs (For more information, see Scanning software CDs.)
5	Profile labels
6	Setup and Support Guide (this book)
7	Paper-path cleaning cloth (for later maintenance use)

Step 2. Install the software

-  **Caution** Do not connect the USB cable to the computer yet. Install the scanning software before connecting the USB cable.

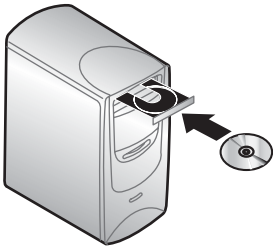

1. Insert the HP Smart Document Scan Solution CD that came with the scanner into the computer CD drive.
Wait for the installation dialog box to display. If the installation dialog box does not display after a few moments, see [Installation dialog box does not display](#).
2. Click **Install Software** to install the scanning software. Follow the onscreen instructions to complete the scanning software installation.



Note There are many options for other software, including some third-party solutions. See [Scanning software CDs](#) for details. If you have any questions about what scanning software to install, click the **How do I choose?** button.

Step 3. Connect the power supply

The power supply has an attached cable that plugs into the back of the scanner. The connector on the end of this cable has a green LED that is on when the power supply is functioning correctly.

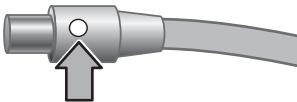

The power supply also has an AC cable that is connected to the power supply on one end and plugged into a power outlet or surge protector on the other end.

1. Plug the AC cable into the back of the power supply.

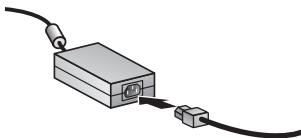

2. Plug the other end of the AC cable into a power outlet or a surge protector.

3. Check that the green LED on the power supply cable connector is on.
 - If the green LED is not on, ensure that power is available to the power outlet or surge protector that the AC cable is plugged into.
 - If power is available to the power outlet or surge protector but the green LED is still not on, the power supply might be defective. Contact HP Support for assistance.
4. If the green LED is on, plug the power supply into the back of the scanner.

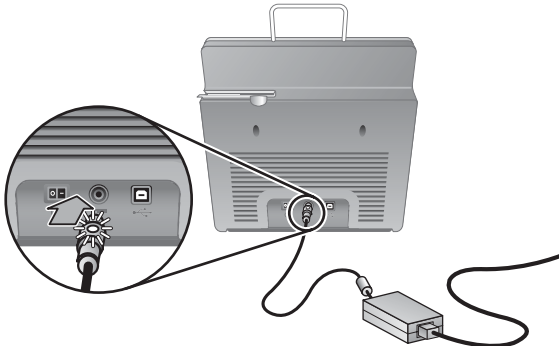

5. Press the **Power** rocker switch on the back of the scanner to the on position to turn the scanner on.

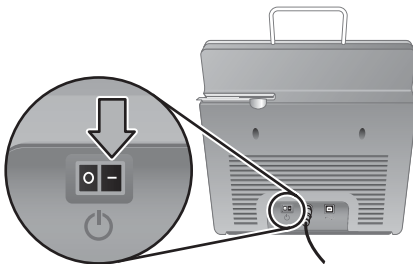

Step 4. Connect the USB cable

 **Caution** Be sure you install the HP Smart Document Scan Software before connecting the scanner to your computer with the USB cable. See [Step 2. Install the software.](#)

Use the USB cable that came with the scanner to connect the scanner to the computer.

1. Connect the square end of the cable to the scanner.

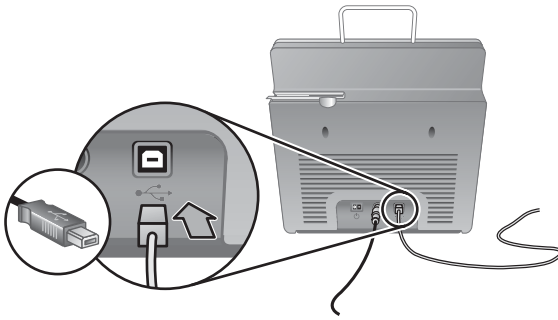

2. Connect the rectangular end of the cable to the computer.

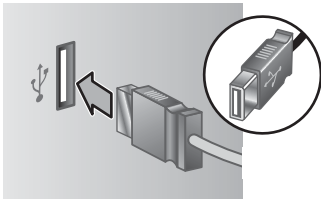

Step 5. Prepare the scanner for use

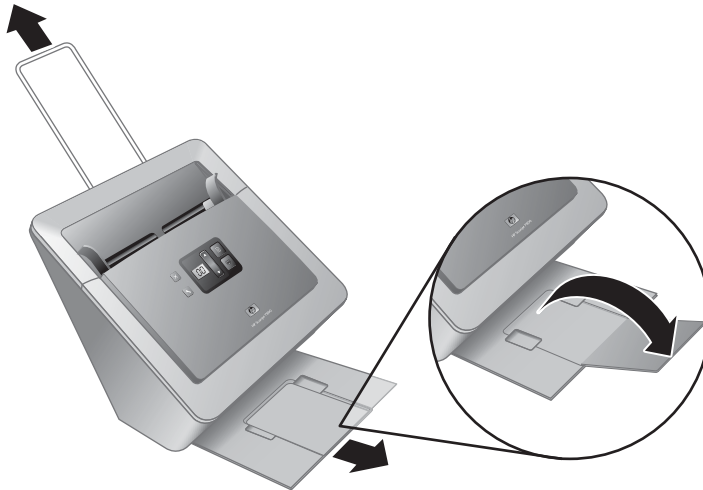

1. For longer originals, extend the document feeder extension.
2. Extend the output tray.

Step 6. Test the installation



Caution Before placing an item in the document feeder, make sure that the item does not contain wet glue, correction fluid, or other substances that can be transferred to the interior of the scanner.

Make sure there are no curls, wrinkles, staples, paper clips, or any other attached material. Sheets should not be stuck together.

1. Place a single page in the document feeder. The page should be face down, with the top of the page pointing down (⌄).

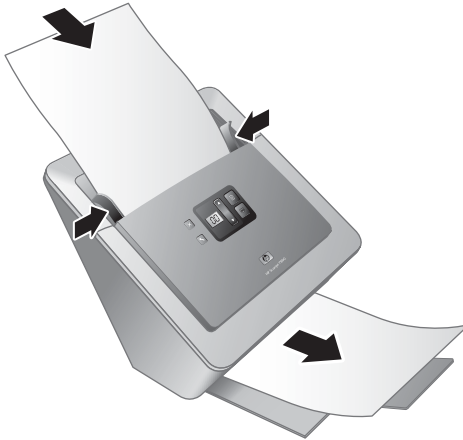

2. Adjust the paper guides. The paper guides must be touching both sides of the page to work properly. Please ensure that the page is straight and the guides are against the edges of the page.
3. Press the **Scan Document To** (🖨️) button.
The page will feed through the scanner. A scan of the page should appear on your computer screen. This confirms that the installation was successful.
If a scan of the page does not appear on your computer screen, see [Troubleshooting](#).
4. Delete the scan.
5. Install any additional software that you want to use.

Scanning software CDs

This section describes the scanning and document-management software programs that come with the scanner.

In addition to the HP software programs, there are several non-HP software programs included. The non-HP software programs are not offered as substitutes for the HP scanning software are not available for all scanner models and countries/regions.

HP Smart Document Scan Software CD

Programs	Software use	Supported operating systems
HP Smart Document Scan Software	Use to create high-quality scans from multi-page documents and to automate scanning tasks you perform often.	Microsoft® Windows® 98 SE, Me, 2000, and XP This program is not available in Asian languages for Windows 98 SE and Me.
ISIS/TWAIN drivers	These drivers are necessary for using the scanner with standard business applications and customized software. They meet the minimum requirement for the scanner to work properly.	Windows 98 SE, Me, 2000, and XP
Kofax Virtual Rescan Software	Use to create clearer and more readable scans from colored or damaged documents.	Windows 2000 and XP
NewSoft Presto! BizCard Reader	Use to scan business cards.	Windows Me, 2000, and XP
Captiva QuickScan Pro Demo	Use to scan, enhance, annotate, print, and store black and white or color documents.	Windows 98, Me, 2000, and XP

ScanSoft PaperPort CD

Programs	Software use	Supported operating systems
ScanSoft PaperPort	Use to organize, find, and share paper and PDF documents.	Windows 98 SE, Me, 2000, and XP for most languages. Some languages support only Windows 2000 and XP.

IRIS Readiris Pro CD

Programs	Software use	Supported operating systems
IRIS Readiris Pro	Use to scan documents for editable text.	Windows 98 SE, Me, 2000, and XP

Power Save mode or Instant Lamp Warm-up mode

The Power Save mode is the default for the scanner. In Power Save mode the scanner lamp will time out and turn off automatically after a period of inactivity (about 15 minutes).

Instant Lamp Warm-up is also available. In this mode, although the scanner lamp will time out and turn off automatically after a period of inactivity (about 15 minutes), it will remain warm and ready to scan.





To switch from Power Save mode to Instant Lamp Warm-up select the Instant Lamp Warm-up option on the General info tab of the Button Settings Utility. To switch back to Power Save mode, clear the Instant Lamp Warm-up option.

2 How to use the scanner buttons and card slot

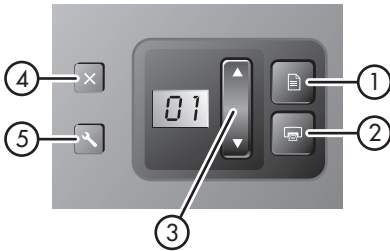
Scanner buttons

Use the buttons on the scanner front panel to start a scan, select a profile for a scan, and configure some scanner settings.



Icon	Button name	Description
1 	Scan Document To	Start a scan (after selecting a profile).
2 	Copy	Start a copy (after selecting the number of copies).
3 	Select Profile Number or Number of Copies	Select a profile (before scanning) or the number of copies (before copying). The selected profile number or number of copies is displayed on the LCD panel.
4 	Cancel	Cancel a scan or copy in progress.
5 	Button Settings	Open the Button Settings Utility where you can work with profiles or view maintenance information.

For more information about the scanner buttons than is provided in this chapter, see the scanner user guide. For information about the scanner user guide, see [Where to get additional information](#).

Card slot

Use the card slot on the back of the scanner to scan items such as business cards, drivers licenses, identification cards, insurance, and other cards.



Caution Do not use cards with raised characters, such as credit cards.

Place cards into the card slot face down with the top of the card pointing to the left (←).



Note Be sure to scan only one card at a time.

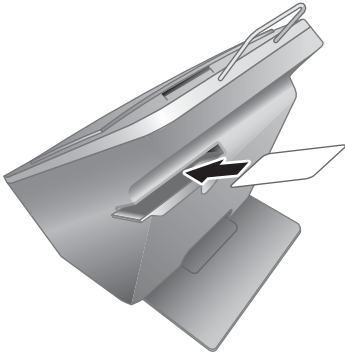

3 Special features

In addition to the standard scanning tools, these special features are available with the included software.

Feature	Description
Profiles	You can set up and use profiles that contain all settings necessary for scanning tasks such as: <ul style="list-style-type: none">• Document processing• Saving in different file formats (i.e. searchable or non-searchable PDF files) using automatic naming mechanisms• Sending to different destinations such as FTP, Microsoft SharePoint, or other applications
Preview pages	Using preview pages, you can check the quality of images before accepting and completing a scan. You can also crop images, which is useful when scanning small items such as a drivers license or a photo.
Page management	You can view, edit, delete, insert, and reorder pages. You can also have the scanner automatically delete blank pages.
File management	You can scan all pages to a single file, scan each page to a separate file, or scan to separate files based on bar codes or blank pages in the original.
Optical Character Recognition (OCR)	With OCR software you can scan originals as editable text that you can send to your favorite application.
Links	You can set up profiles to send files to different destinations via local or global network connections.
Wide range of sizes	You can scan originals ranging from legal-size paper to checks. You can use the card slot on the back of the scanner to scan items such as business cards, drivers licenses, identification cards, insurance, and other cards.

4 How to set up and use profiles

An HP Smart Document Scan Software profile contains settings for scanning, processing, and saving or sending scanned documents. You can set up profiles for use with the **Scan Document To** button. The profiles provide a fast, efficient way to scan. You can configure each profile to perform specific scanning functions that you use often. For example, if you frequently need to scan originals at 200 dpi color, create a PDF file, and save the file in a folder named Archives within a folder named 2005, you can create a profile with the necessary settings to accomplish this task.

Use HP Smart Document Scan Software to set up and modify profiles. Use the Button Settings Utility to assign a number to each profile. After you have set up a profile, you can use the same settings simply by selecting the profile in the LCD of the front panel.

- [Set up a profile with HP Smart Document Scan Software](#)
- [Assign profile numbers with the Button Settings Utility](#)
- [Modify a profile with HP Smart Document Scan Software](#)
- [Import and export profiles](#)
- [Customizable profile labels](#)

Set up a profile with HP Smart Document Scan Software

1. To open HP Smart Document Scan Software, do one of the following:
 - Double-click the **HP Smart Document Scan Software** icon on the computer desktop.



- Click **Start**, point to **Programs** or **All Programs**, point to **HP**, point to **Scanjet**, point to **7800**, and then click **HP Smart Document Scan Software**.
2. Click **New**.
The Create New Profile dialog box is displayed.
3. In the **Profile name** box, type the name you want or accept the default name.
 **Tip** You might want to set up the new profile based on an existing one. To do so, check the **Copy settings from profile** check box and select an existing profile from the list.
4. Click **Continue**.
The Profile Settings dialog box is displayed.
5. Use the **Scan**, **Process**, and **Destination** tabs to select the settings for the profile. If you have set up the new profile based on an existing one, the existing profile's settings are displayed. Otherwise, the new profile's settings, such as paper size, target folder, etc., default to the most commonly used values.
6. After completing all settings go back to the **Profile** tab to summarize the most typical characteristics of the profile (such as document types and formats, separation criterion, destination link) in the **Description** box.
7. Click **OK**.

For more information, see the HP Smart Document Scan Software help. Double-click the **HP Smart Document Scan Software** icon on the computer desktop, and then click **Help** in the toolbar menu.

Assign profile numbers with the Button Settings Utility

Use the Button Settings Utility to assign each profile to a number. Profiles represented as numbers are easily selected from the LCD.



Note Because the profile number in the LCD panel returns to **01** after being idle for 20 seconds, it is a good idea to assign commonly used profiles to lower numbers.

1. To open the Button Settings Utility, do one of the following:
 - Double-click the **Button Settings Utility** icon on the computer desktop.



- Press the Button Settings () button on the front panel of the scanner.
 - Click **Start**, point to **Programs** or **All Programs**, point to **HP**, point to **Scanjet**, point to **7800**, and then click **Button Settings Utility**.
2. Select the button number in the **Select button to configure** area of the dialog box.
3. Click a profile name in the **Choose profile for selected button** list.
4. Click **OK**.

Modify a profile with HP Smart Document Scan Software

To modify a profile, follow these steps:

1. To open HP Smart Document Scan Software, do one of the following:
 - Double-click the **HP Smart Document Scan Software** icon on the computer desktop.



- Click **Start**, point to **Programs** or **All Programs**, point to **HP**, point to **Scanjet**, point to **7800**, and then click **HP Smart Document Scan Software**.
2. Select the profile that you want to modify from the **Select a scan profile list**.
3. Click **Edit**.

For more information, see the HP Smart Document Software help. Double-click the **HP Smart Document Scan Software** icon on the computer desktop, and then click **Help** in the toolbar menu.

Import and export profiles

Profiles can be exported into and imported from an XML file so that administrators can set up profiles for a workgroup, users can transfer their profiles from one machine to another, and users can share custom profiles with each other.

For more information, see the HP Smart Document Scan Software help. Double-click the **HP Smart Document Scan Software** icon on the computer desktop, and then click **Help** in the toolbar menu.

Customizable profile labels

Use the customizable profile labels included with the scanner to list up to twelve commonly used profile numbers and profiles associated with them. The label can be attached directly to the pull-down tray on the front of the scanner.

01	Simplex/Duplex, Pg. Sz., DPI, B&W/Color, PDF/OCR, Save to	07	Simplex/Duplex, Pg. Sz., DPI, B&W/Color, PDF/OCR, Save to
02	Simplex/Duplex, Pg. Sz., DPI, B&W/Color, PDF/OCR, Save to	08	Simplex/Duplex, Pg. Sz., DPI, B&W/Color, PDF/OCR, Save to
03	Simplex/Duplex, Pg. Sz., DPI, B&W/Color, PDF/OCR, Save to	09	Simplex/Duplex, Pg. Sz., DPI, B&W/Color, PDF/OCR, Save to
04	Simplex/Duplex, Pg. Sz., DPI, B&W/Color, PDF/OCR, Save to	10	Simplex/Duplex, Pg. Sz., DPI, B&W/Color, PDF/OCR, Save to
05	Simplex/Duplex, Pg. Sz., DPI, B&W/Color, PDF/OCR, Save to	11	Simplex/Duplex, Pg. Sz., DPI, B&W/Color, PDF/OCR, Save to
06	Simplex/Duplex, Pg. Sz., DPI, B&W/Color, PDF/OCR, Save to	12	Simplex/Duplex, Pg. Sz., DPI, B&W/Color, PDF/OCR, Save to

Sample profile label

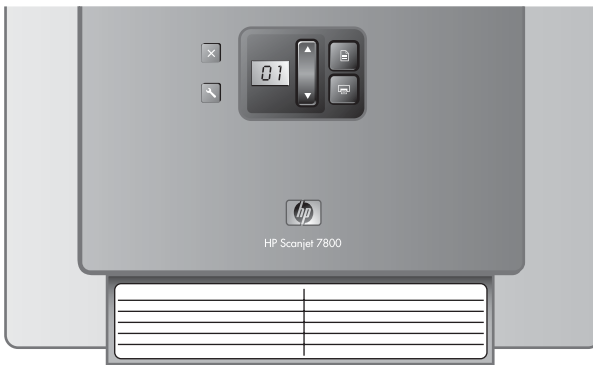

For a template that you can print if you need additional customizable profile labels, use the `label_template.doc` file located on the scanner software CD.

To customize and print a profile label, follow these steps:

1. Open the template in Microsoft Word.
2. Double-click the text form field to the right of the profile number. The dialog box is displayed.
3. Click in the **Default text** field, and then enter a short description of the profile.
4. Repeat steps 2 and 3 for each profile description you want to enter.
5. Click **OK**.
6. Before printing on the label sheet, print the label on a plain sheet of paper. Place the test print over a label sheet to verify that the text aligns with the label cutout.
7. Print on the label sheet.
8. Place the label on the pull-down tray on the front of the scanner.

5 Where to get additional information

The scanner comes with several sources of information about using the scanner and the scanning software.

- [HP Scanjet 7800 User Guide](#)
- [HP Smart Document Scan Software help](#)
- [Button Settings Utility help](#)

HP Scanjet 7800 User Guide

The scanner user guide provides the information you need to know for using, maintaining, and troubleshooting the scanner. The scanner user guide is the primary source for scanner information. The user guide is available as a PDF file, so that you can print all or parts of it, and as a screen-readable CHM.

To open the user guide PDF:

- Click **Start**, point to **Programs** or **All Programs**, point to **HP**, point to **Scanjet**, point to **7800**, and then click **User Guide**.

For a PDF version of the user guide in another language:

1. Insert the HP Smart Document Scan Solution CD that came with the scanner into the computer CD drive.
Wait for the installation dialog box to display.
2. Click **View or print guides**.
A list of languages is displayed.
3. Click the language that you want.
A list of guides is displayed.
4. Click **Printable User Guide**.

For a screen-readable CHM version of the user guide:

1. Insert the HP Smart Document Scan Solution CD that came with the scanner into the computer CD drive.
Wait for the installation dialog box to display.
2. Click **View or print guides**.
A list of languages is displayed.
3. Click the language that you want.
A list of guides is displayed.
4. Click **Onscreen User Guide**.

HP Smart Document Scan Software help

You can use HP Smart Document Scan Software help to learn how to use HP Smart Document Scan Software features, such as creating and editing profiles.

To open HP Smart Document Scan Software help, click **Help** on the HP Smart Document Scan Software toolbar.

Button Settings Utility help

If HP Smart Document Scan Software is installed on the computer, you can use the Button Settings Utility help to learn what options are available for configuring the scanner profiles and how to find information about scanner status and maintenance.

To open the Button Settings Utility help, click **Help** on the Button Settings Utility dialog box.

6 Care and maintenance

Occasional cleaning of the scanner helps ensure higher-quality scans. The amount of care necessary depends upon several factors, including the amount of use and the environment. You should perform routine cleaning as necessary.

For instructions about maintaining the scanner, see the scanner user guide. For information about the scanner user guide, see [Where to get additional information](#).



Caution Before placing an item in the document feeder, make sure that the item does not contain wet glue, correction fluid, or other substances that can be transferred to the interior of the scanner.

Make sure there are no curls, wrinkles, staples, paper clips, or any other attached material. Sheets should not be stuck together.

7 Troubleshooting

Installation dialog box does not display

Follow these steps if the installation dialog box does not display:

1. Click **Start**, and then click **Run**.
The Run dialog box is displayed.
2. In the **Open** box, type `d:\setup.exe` (where d: is the letter of your computer's CD drive).
3. Click **OK**.

Scanner error codes

The scanner displays a blinking number on the LCD panel when it encounters a problem, such as a paper jam. For more information, see [Scanner error codes](#) at the end of this book.

Other sources for help

For more troubleshooting help with the scanner hardware or software, see [Where to get additional information](#).

Scanner does not work after installation

If the scanner does not work after installation, you might see one of the following messages displayed on the computer:

- The scanner could not be initialized.
- The scanner could not be found.
- An internal error has occurred.
- The computer cannot communicate with the scanner.

Try the following to fix the problem:

Step 1. Check the cables

Verify that the cable connections are in working order.

Power supply

The power supply has an attached cable that plugs into the back of the scanner. The connector on the end of this cable has a green LED that is on when the power supply is functioning correctly.

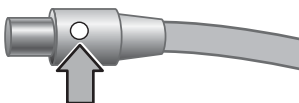

The power supply also has an AC cable that is connected to the power supply on one end and plugged into a power outlet or surge protector on the other end.

The power cable is connected between the scanner and a power outlet.

1. Check that the power rocker switch is in the on position.
2. Check that the green LED on the power supply cable connector is on.
3. If the green LED is not on, ensure that power is available to the power outlet or surge protector that the AC cable is plugged into.
4. If power is available to the power outlet or surge protector but the green LED is still not on, the power supply might be defective. Contact HP Support for assistance.

USB cable

Check the physical connection to the scanner:

- Use the cable that was included with the scanner. Another USB cable might not be compatible with the scanner.
- Ensure that the USB cable is securely connected between the scanner and the computer or USB hub. The trident icon on the USB cable faces up when the cable is properly connected to the scanner.

To troubleshoot the USB connection:

1. Do one of the following tasks depending on how the scanner is connected to the computer:
 - If the USB cable is connected to a USB hub or a docking station for a laptop, disconnect the USB cable from the USB hub or the docking station, and then connect the USB cable directly to the computer.
 - If the USB cable is directly connected to the computer, plug it into another USB port on the computer.
 - Remove all other USB devices from the computer except for the keyboard and the mouse.
2. Turn the scanner off and then on.
3. Restart the computer.
4. After the computer has restarted, try using the scanner.

If the scanner works and you changed the way it was connected to the computer in step 1, the communication problem might involve the USB hub or docking station. Leave the scanner directly connected to the computer.

If the scanner does not work, uninstall and then reinstall the HP scanning software.

Step 2. Uninstall and then reinstall the HP scanning software

If checking the scanner cable connections did not solve the problem, the problem might have occurred because of an incomplete installation. Try uninstalling and then reinstalling the HP scanning software.

1. Disconnect the USB cable from the computer.
2. Do one of the following tasks to open the **Control Panel**:
 - Windows XP: Click **Start**, and then click **Control Panel**.
 - Windows 98 SE, Me, or 2000: Click **Start**, point to **Settings**, and then click **Control Panel**.
3. Double-click the **Add/Remove Programs** icon.

- A list of currently installed programs is displayed.
4. Select **HP Scanjet 7800 Specialized Document Scanning**, and then click **Remove** or **Change/Remove**.
 5. Follow the onscreen instructions.
If prompted to remove or repair the software, click **Remove**.
If prompted to restart the computer, click **No**.
 6. After the HP scanning software is removed, unplug the scanner from the electrical outlet.
 7. Restart the computer.
 8. Insert the HP Smart Document Scan Solution CD in the computer CD drive.
 9. Follow the onscreen instructions to install the HP scanning software.
 10. After the HP scanning software has installed, connect the scanner to an electrical outlet, turn on the scanner, and then use the USB cable to connect the scanner to the computer.
 11. Follow the onscreen instructions.

8 Product support

This section describes the options for product support.

- [Accessibility](#)
- [HP Scanjet Web site](#)
- [Support process](#)

Accessibility

The following accessibility options are available on this scanner:

- The LCD Reader displays the contents of the scanner's LCD as it changes. It enables PC accessibility tools to help the user read what is being displayed on the LCD.
- To prevent buttons from being accidentally pushed, you can use the Button Disable Utility to disable the buttons. You can use the same utility to re-enable the buttons.

For more information about the LCD Reader and Button Disable Utility, see the scanner user guide. For information about the scanner user guide, see [Where to get additional information](#).

Customers with disabilities can get help by visiting www.hp.com/hpinfo/community/accessibility/prodserv/.

HP Scanjet Web site

Visit www.hp.com and select your country/language at the top of the page. On the country page, select scanners from the list of products. Use this site for a variety of information:

- Learn tips for scanning more effectively and creatively.
- Gain access to HP Scanjet driver updates and software.
- Register your product.
- Subscribe to newsletters, driver and software updates, and support alerts.
- Purchase scanner supplies.

Support process

The HP support process works most effectively if you perform the following steps in the order specified:

1. Review the onscreen Help and user guide for the software and scanner, including the troubleshooting sections.
2. If you have access to the Internet, you can obtain a wide range of information about your scanner. Visit the HP Technical Support Web site for product help, drivers, and software updates at www.hp.com/support.
3. Use HP e-support. If you have access to the Internet, connect with HP by going to www.hp.com/support. Select **Support and Troubleshooting**, enter the scanner model information, and then click the double arrows. At the bottom of the next page, select e-mail under **Collaborative Resources**. You will receive a personal reply

from an HP Product Support technician. E-mail support is available in the languages listed at that Web site.

4. If you are a customer in the United States, go to step 5. Otherwise, contact your local HP dealer. If your scanner has a hardware failure, take it to your local HP dealer for a solution. Service is free during your scanner's limited warranty period. After the warranty period, the dealer will quote a service charge.
5. Contact the HP Product Support Center for support by phone. Please consult the following Web site to check the details and conditions of phone support in your country/region: www.hp.com/support. Call HP while you are in front of your computer and scanner. For faster service, please be prepared to provide the following information:
 - Scanner model number (located on the scanner)
 - Scanner serial number (located on the scanner)
 - Computer operating system
 - Version of the scanner software (located on the scanner's CD label)
 - Messages displayed at the time the situation occurred

The applicable conditions for HP phone support are subject to change without notice. Telephone support is free from the date of purchase for the period specified unless otherwise noted.

9 Regulatory information and product specifications

This section contains regulatory information and product specifications for the HP Scanjet 7800 scanner and accessories.

- [Scanner specifications](#)
- [Environmental specifications](#)
- [Regulatory information](#)
- [Recycle and restricted material information](#)
- [Disposal of Waste Equipment by Users in Private Households in the European Union](#)

Scanner specifications

Name	Description
Scanner type	Duplex sheet-feed scanner
Size	Width: 320 mm (12.6 in), Depth: 270 mm (10.63 in), Height: 312 mm (12.28 in)
Weight	5.4 kg (11.8 lbs)
Scanning element	Charge-coupled device (CCD)
Interface	USB 2.0 high-speed
Optical resolution	1200 x 1200 dpi hardware
AC power	100-240V~, 50/60Hz, 1.5A
Power consumption	For power consumption, data see the regulatory_supplement.htm file on the HP Smart Document Scan Software CD.
	Your HP scanner is ENERGY STAR® compliant. As an ENERGY STAR® partner, Hewlett-Packard Company has determined that this product meets the ENERGY STAR® guidelines for energy efficiency.

Environmental specifications

Name	Description
Temperature	Operating the scanner: 10° to 35° C (50° to 95° F)
	Storage: -40° to 60° C (-40° to 140° F)

(continued)

Name	Description
Relative humidity	Operating the scanner: 15 percent to 80 percent noncondensing 10° to 35° C (50° to 95° F)
	Storage: up to 90 percent at 0° to 60° C or (32° to 140° F)

Regulatory information

Regulatory Model Identification Number: For regulatory identification purposes your product is assigned a Regulatory Model Number. The Regulatory Model Number for your product is FCLSD-0601. This regulatory number should not be confused with the marketing name (HP Scanjet 7800) or product numbers (L1960A, L1965A, L1966A, L1967A). Additional regulatory information about your scanner can be found on the regulatory_supplement.htm file on the HP Smart Document Scan Software CD.



Note The regulatory label (with the part numbers and serial numbers) is on the bottom of the scanner. However, when you insert the output paper tray on the bottom of the scanner, you will cover up the regulatory label.

Recycle and restricted material information

- [Recycling](#)
- [Product restricted material](#)

Recycling

Recycling, energy consumption, and environmental information is located on the HP Smart Document Scan Software CD that comes with the scanner. On the CD, browse for the file named recycle_supplement.pdf.

Product restricted material

This HP product contains the following material that might require special handling at end-of-life: Mercury in the scanner fluorescent lamp and transparent materials adapter (< 5 mg).

For recycling information, contact www.hp.com/go/recycle, your local authorities, or the Electronic Industries Alliance at www.eiae.org.

Disposal of Waste Equipment by Users in Private Households in the European Union



This symbol on the product or on its packaging indicates that this product must not be disposed of with your other household waste. Instead, it is your responsibility to dispose of your waste equipment by handing it over to a designated collection point for the recycling of waste electrical and electronic equipment. The separate collection and recycling of your waste equipment at the time of disposal will help to conserve natural resources and ensure that it is recycled in a manner that protects human health and the environment. For more information about where you can drop off your waste equipment for recycling, please contact your local city office, your household waste disposal service, or the shop where you purchased the product.

10 Hewlett-Packard limited warranty statement

HP Scanjet 7800 scanner

- [Duration of limited warranty](#)
- [Regions](#)

Duration of limited warranty

1. HP warrants to you, the end-user customer, that HP hardware, accessories, and supplies will be free from defects in materials and workmanship after the date of purchase, for one year. If HP receives notice of such defects during the warranty period, HP will, at its option, either replace or repair products which prove to be defective. Replacement products may be either new or equivalent in performance to new.

2. HP warrants to you that HP software will not fail to execute its programming instructions after the date of purchase, for the period specified above, due to defects in material and workmanship when properly installed and used. If HP receives notice of such defects during the warranty period, HP will replace software which does not execute its programming instructions due to such defects.

3. HP does not warrant that the operation of HP products will be uninterrupted or error free. If HP is unable, within a reasonable time, to repair or replace any product to a condition as warranted, you will be entitled to a refund of the purchase price upon prompt return of the product.

4. HP products may contain remanufactured parts equivalent to new in performance or may have been subject to incidental use.

5. This warranty does not apply to defects resulting from (a) improper or inadequate maintenance or calibration, (b) software, interfacing, parts, or supplies not supplied by HP, (c) unauthorized modification or misuse, (d) operation outside of the published environmental specifications for the product, or (e) improper site preparation or maintenance.

6. TO THE EXTENT ALLOWED BY LOCAL LAW, THE ABOVE WARRANTIES ARE EXCLUSIVE AND NO OTHER WARRANTY OR CONDITION, WHETHER WRITTEN OR ORAL, IS EXPRESSED OR IMPLIED, AND HP SPECIFICALLY DISCLAIMS ANY IMPLIED WARRANTIES OR CONDITIONS OF MERCHANTABILITY, SATISFACTORY QUALITY, AND FITNESS FOR A PARTICULAR PURPOSE. Some countries, states, or provinces do not allow limitations on the duration of an implied warranty, so the above limitation or exclusion might not apply to you. This warranty gives you specific legal rights, and you might also have other rights that vary from country to country, state to state, or province to province.

7. HP's limited warranty is valid in any country or locality where HP has a support presence for this product and where HP has marketed this product. The level of warranty service you receive may vary according to local standards. HP will not alter the form, fit, or function of the product to make it operate in a country in which it was never intended to function for legal or regulatory reasons.

8. TO THE EXTENT ALLOWED BY LOCAL LAW, THE REMEDIES IN THIS WARRANTY STATEMENT ARE YOUR SOLE AND EXCLUSIVE REMEDIES. EXCEPT

AS INDICATED ABOVE, IN NO EVENT WILL HP OR ITS SUPPLIERS BE LIABLE FOR LOSS OF DATA OR FOR DIRECT, SPECIAL, INCIDENTAL, CONSEQUENTIAL (INCLUDING LOST PROFIT OR DATA), OR OTHER DAMAGE, WHETHER BASED IN CONTRACT, TORT, OR OTHERWISE. Some countries, states, or provinces do not allow the exclusion or limitation of incidental or consequential damages, so the above limitation or exclusion may not apply to you.

9. THE WARRANTY TERMS CONTAINED IN THIS STATEMENT, EXCEPT TO THE EXTENT LAWFULLY PERMITTED, DO NOT EXCLUDE, RESTRICT, OR MODIFY AND ARE IN ADDITION TO THE MANDATORY STATUTORY RIGHTS APPLICABLE TO THE SALE OF THIS PRODUCT TO YOU.

Regions

- [Asia Pacific](#)
- [Americas](#)
- [Europe, Middle East, and Africa](#)

Asia Pacific

Service and support

HP Technical Support is your easy, fast, and direct Web resource for product assistance, diagnostics, and driver downloads. It is your source for all service and support needs. Receive award-winning assistance 24 hours per day, 7 days a week at www.hp.com/support.

Upgraded warranty option

You can upgrade your standard factory warranty to three years “Next business day” exchange with the HP Care Pack service. Service coverage begins on product purchase date and the pack must be purchased and registered by HP within the first year of product purchase.

This warranty upgrade offers maximized uptime and productivity, the convenience of door-to-door pickup with delivery, packaging and freight prepaid by HP.

For more information please refer to: www.hp.com/hps/index_support

Post-warranty period service and support

After the warranty period of your HP product, you have different options depending on the region where you reside. See Call Options and Service Options for more information.

- **Call options**
You can call the Support Center. A "per incident" fee will be charged.
- **Service options**
You can replace the hardware for a fee. You will have access to HP Technical Support at www.hp.com/support for 3 years.

Americas

Service and support

HP Technical Support is your easy, fast, and direct Web resource for product assistance, diagnostics, and driver downloads. It is your source for all service and support needs. Receive award-winning assistance 24 hours per day, 7 days a week at www.hp.com/support.

Upgraded warranty option

You can select the following upgraded warranty option (available in the U.S. only):

Standard Next Day Exchange

Post-warranty period service and support

After the warranty period of your HP product, you have different options depending on the region where you reside. See Call Options and Service Options for more information.

- **Call options**

Latin America: You can call the Support Center. A fee will be charged.

United States and Canada: You can call the Support Center, however there will be a "per incident" fee.

- **Service options**

Latin America: You can repair or return hardware for a fee OR upgrade replacement for a fee.

United States: You can replace hardware for a fee OR upgrade for a fee.

Canada: You can repair or return hardware, and for a fee have a 3 to 5 day turnaround time.

Any customer will have access to HP Technical Support at www.hp.com/support for 3 years.

Europe, Middle East, and Africa

Names and addresses of the HP entities which grant HP's Limited Warranty (manufacturer's warranty) in your country are as follows.

Čeština

Česká republika

HEWLETT-PACKARD s.r.o.
Vyskočilova 1/1410
140 21 Praha 4

Dansk

Danmark

Hewlett-Packard A/S
Engholm Parkvej 8
DK-3450 Allerød

Deutsch

Deutschland

Hewlett-Packard GmbH
Herrenberger Straße 140
D-71034 Böblingen

Deutsch

Luxemburg

Hewlett-Packard Luxembourg SCA
7a, rue Robert Stümper
L-2557 Luxembourg-Gasperich

Deutsch

Österreich

Hewlett-Packard Ges.m.b.H.
Lieblgasse 1
A-1222 Wien

Eesti

Estonia

HP Oy Eesti Filiaal
Estonia pst. 1
EE-10143 Tallinn

Ελληνικά

Ελλάδα/ Cyprus

Hewlett-Packard Hellas E.Π.Ε.
Βορείου Ηπείρου 76
151 25 ΜΑΡΟΥΣΙ

English

Ireland

Hewlett-Packard Ireland Ltd.
30 Herbert Street
IRL-Dublin 2

English

United Kingdom

Hewlett-Packard Ltd
Cain Road
Bracknell
GB-Berks RG12 1HN

Español

España

Hewlett-Packard Española S.L.
C/ Vicente Aleixandre 1
Parque Empresarial Madrid - Las Rozas
28230 Las Rozas
Madrid

Français

Belgique

Hewlett-Packard Belgium BVBA/SPRL
1, rue de l'Aéronef
B-1140 Brussels

Français

France

Hewlett-Packard France, SAS
80, rue Camille Desmoulins
92788 Issy les Moulineaux Cedex 9

Français

Luxemburg

Hewlett-Packard Luxembourg SCA
7a, rue Robert Stümper
L-2557 Luxembourg-Gasperich

Italiano

Italia /Malta

Hewlett-Packard Italiana S.p.A
Via G. Di Vittorio 9
20063 Cernusco sul Naviglio

Latviešu

Latvia

Hewlett-Packard SIA
Palasta iela 7
Riga, LV-1050

Lietuvių

Lietuva

UAB "Hewlett-Packard"
Šeimyniškių g. 21B - 308
LT-2051 Vilnius

Magyar

Hungary

Hewlett-Packard Magyarország Kft.
1117 Budapest
Neumann J. u. 1.

Nederlands

Belgique

Hewlett-Packard Belgium BVBA/SPRL
Luchtschipstraat 1
B-1140 Brussels

Nederlands

Nederland

Hewlett-Packard Nederland BV
Orteliuslaan 1000
3528 BD Utrecht

Polski

Polska

Hewlett-Packard Polska Sp. z o.o.
ul. Szturmowa 2A
02-678 Warszawa
wpisana do rejestru
przedsiębiorcow
w Sądzie Rejonowym dla m.st.
Warszawy, XX Wydział
Gospodarczy pod numerem
KRS 0000016370

Português

Portugal

Hewlett-Packard Portugal, Lda.
Edifício D. Sancho I
Quinta da Fonte
Porto Salvo
2780-730 Paco de Arcos
P-Oeiras

Slovenčina

Slovenská republika

Hewlett-Packard Slovakia, s.r.o.
Galvaniho 7
820 02 Bratislava

Slovenski

Slovenija

Hewlett-Packard d.o.o.
Tivolska cesta 48
1000 Ljubljana

Suomi

Suomi

Hewlett-Packard Oy
Piispankalliontie
FIN-02200 Espoo

Svenska

Sverige

Hewlett-Packard Sverige AB
SE-169 85 Stockholm

You may also have statutory legal rights against the seller on the basis of the purchase agreement in addition to the manufacturer's warranty, which are not restricted by this manufacturer's warranty.

Service and support

HP Technical Support is your easy, fast, and direct Web resource for product assistance, diagnostics, and driver downloads. It is your source for all service and support needs.

Receive award-winning assistance 24 hours per day, 7 days a week at www.hp.com/support.

Upgraded warranty option

You can upgrade your standard factory warranty to three years "Next business day" exchange with the HP Care Pack service.

Service coverage begins on product purchase date and the pack must be purchased and registered by HP within the first year of product purchase. You will benefit from a dedicated access (phone number) to HP hardware technical support. In case it is determined that your product needs replacement, HP will ship you a replacement product on the next contracted business day free of charge.

This warranty upgrade offers maximized uptime and productivity, the convenience of door-to-door pickup with delivery, and packaging and freight prepaid by HP.

Europe/Middle East/Africa warranty upgrade Web sites

- www.hp.com/fr/extension-garantie for France
- www.hp.com/uk/warranty-extension for UK
- www.hp.nl/garantie-uitbreiding for Holland
- www.hp.com/it/estensione-garanzia for Italy
- www.hp.com/es/extensiones-garantia for Spain
- www.hp.com/de/garantie-erweiterung for Germany
- www.hp.com/se/garantiforlangning for Sweden
- www.hp.com/dk/garantiudvidelse for Denmark
- www.hp.com/fi/takuunlaajennus for Finland
- www.hp.com/be/garantie-uitbreiding for Belgium (dutch)
- www.hp.com/be/extension-garantie for Belgium (french)
- www.hp.com/pt/extensao-de-garantia for Portugal
- www.hp.com/ie/warranty-extension for Ireland

Countries not listed : For more information, please check with your local reseller.

Post-warranty period service and support

After the warranty period of your HP product, you have different options depending on the region where you reside. See Call Options and Service Options for more information.

- **Call options**
You can go back to the dealer or call the Customer Support Center, however there will be a "per incident" fee.
- **Service options**
You can take product back to the dealer or call the Customer Support Center for replacement of product for a fee. You will have access to HP Technical Support at www.hp.com/support for 3 years.

A Scanner error codes

The scanner displays a blinking number on the LCD under certain error conditions. For help responding to an error code, see the appropriate topic below.

Error 02 SDRAM Error

Press the Power rocker switch to the off position to turn the scanner off. Wait 30 seconds, and then press the Power rocker switch to the on position to turn the scanner on. If the message is still displayed, contact HP Support. For more information, see [Product support](#).

Error 03 USB Error

1. Check the USB connection between the scanner and the computer. For more help, see [Step 4. Connect the USB cable](#).
2. Verify that the scanner is recognized by the computer. If not, try uninstalling and then reinstalling the software.
3. If the problem persists, contact HP Support. For more information, see [Product support](#).

Error 04 Paper Jam

A document feeder paper jam has been detected. Open the hatch and clear the jam.

Error 08 Hatch Open

The hatch on the document feeder is open or not securely latched. Please close the hatch by pressing until you hear a click, and then rescan.

Error 09 NVRAM ACCESS Error

Press the Power rocker switch to the off position to turn the scanner off. Wait 30 seconds, and then press the Power rocker switch to the on position to turn the scanner on. If the message is still displayed, contact HP Support. For more information, see [Product support](#).

Error 10 Motor Fail

Press the Power rocker switch to the off position to turn the scanner off. Wait 30 seconds, and then press the Power rocker switch to the on position to turn the scanner on. If the message is still displayed, contact HP Support. For more information, see [Product support](#).

Error 23 Lamp Error

Press the Power rocker switch to the off position to turn the scanner off. Wait 30 seconds, and then press the Power rocker switch to the on position to turn the scanner on. If the message is still displayed, contact HP Support. For more information, see [Product support](#).

Error 24 Pick Failure

The document feeder cannot pick up the paper or the paper is jammed. Follow these steps to resolve the error:

1. Remove the paper from the document feeder.
2. Sort through the stack to make sure the sheets are not stuck together.
3. Make sure the paper meets the size and weight specifications, as specified in the onscreen user guide.