

iBusway for Data Center

Metered Feed Units and Metered Tap Off Units

Operation Manual Configuration of Metering Solution

990-5313-001

Publication Date: June 2014



Schneider Electric Legal Disclaimer

The information presented in this manual is not warranted by Schneider Electric to be authoritative, error free, or complete. This publication is not meant to be a substitute for a detailed operational and site specific development plan. Therefore, Schneider Electric assumes no liability for damages, violations of codes, improper installation, system failures, or any other problems that could arise based on the use of this Publication.

The information contained in this Publication is provided as is and has been prepared solely for the purpose of evaluating data center design and construction. This Publication has been compiled in good faith by Schneider Electric. However, no representation is made or warranty given, either express or implied, as to the completeness or accuracy of the information this Publication contains.

IN NO EVENT SHALL SCHNEIDER ELECTRIC, OR ANY PARENT, AFFILIATE OR SUBSIDIARY COMPANY OF SCHNEIDER ELECTRIC OR THEIR RESPECTIVE OFFICERS, DIRECTORS, OR EMPLOYEES BE LIABLE FOR ANY DIRECT, INDIRECT, CONSEQUENTIAL, PUNITIVE, SPECIAL, OR INCIDENTAL DAMAGES (INCLUDING, WITHOUT LIMITATION, DAMAGES FOR LOSS OF BUSINESS, CONTRACT, REVENUE, DATA, INFORMATION, OR BUSINESS INTERRUPTION) RESULTING FROM, ARISING OUT, OR IN CONNECTION WITH THE USE OF, OR INABILITY TO USE THIS PUBLICATION OR THE CONTENT, EVEN IF SCHNEIDER ELECTRIC HAS BEEN EXPRESSLY ADVISED OF THE POSSIBILITY OF SUCH DAMAGES. SCHNEIDER ELECTRIC RESERVES THE RIGHT TO MAKE CHANGES OR UPDATES WITH RESPECT TO OR IN THE CONTENT OF THE PUBLICATION OR THE FORMAT THEREOF AT ANY TIME WITHOUT NOTICE.

Copyright, intellectual, and all other proprietary rights in the content (including but not limited to software, audio, video, text, and photographs) rests with Schneider Electric or its licensors. All rights in the content not expressly granted herein are reserved. No rights of any kind are licensed or assigned or shall otherwise pass to persons accessing this information.

This Publication shall not be for resale in whole or in part.

Table of Contents

- Safety Precautions..... 1
 - Important Safety Information 1
 - Standard Application Precautions 2
- Labels..... 3
 - Tap Off Unit Nameplate 3
 - Busway Nameplate 3
- iBusway for Data Center Metering Overview..... 4
 - Metering Connection 4
 - Serial Modbus Daisy Chain 4
- Power Meter (PM5350xB)..... 5
 - PM5350xB Communication Setup 5
 - Setting Up the Modbus Address 5
- Power Feed Unit / EGX Tap Off Unit 6
 - EGX300 Configuration 6
 - Ethernet Configuration 6
 - Ethernet Setup Using a Web Browser 6
 - Set Up the Device List 6
 - Device Discovery 7
 - Configure EGX300 IP address 7
- Configure the Date and Time..... 8
 - Set the date and time of the EGX300 Ethernet Gateway 8
 - Reset the date and time of a Power Meter at the EGX300 Web interface: 8
 - Set the date and time of the Power Meter at its LCD interface 8
- Reset Device Parameters..... 9
 - Reset the Power Meter from the EGX300 Web interface 9
 - Reset the Power Meter from its LCD interface 9
- Reset Passwords..... 10
 - Reset the Power Meter passwords 10
 - Reset the EGX300 password 10

Safety Precautions

Read the instructions carefully to become familiar with the device before trying to install, operate, service or maintain it. The following messages may appear throughout this manual or on the equipment to warn of potential hazards or to call attention to information that clarifies or simplifies a procedure.

Important Safety Information

This manual contains important instructions that must be followed during the installation and customization of equipment.



The addition of this symbol to a Danger or Warning safety label indicates that an electrical hazard exists which will result in personal injury if the instructions are not followed.



This is the safety alert symbol. It is used to alert you to potential personal injury hazards. Obey all safety messages that follow this symbol to avoid possible injury or death.

⚠ DANGER

DANGER indicates an imminently hazardous situation which, if not avoided, **will result in** death or serious injury.

⚠ WARNING

WARNING indicates a potentially hazardous situation which, if not avoided, **can result in** death or serious injury.

⚠ CAUTION

CAUTION indicates a potentially hazardous situation which, if not avoided, **can result in** minor or moderate injury.

CAUTION

CAUTION, used without the safety alert symbol, indicates a potentially hazardous situation which, if not avoided, **can result in** equipment damage.

NOTICE

NOTICE addresses practices not related to physical injury including certain environmental hazards, potential damage or loss of data.

Standard Application Precautions

DANGER

HAZARD OF ELECTRIC SHOCK, EXPLOSION, OR ARC FLASH

- This tap off unit must be installed and serviced only by qualified electrical personnel.
- Turn off power to the busway before installing or removing the tap off unit.
- Always use a properly rated voltage tap off unit for the particular busway application.
- Only install tap off units on busway sections with the same bus bar configurations, for example: 3 A to 3 A, 4 A to 4 A, 4 B to 4 B, 5 A to 5 A, and 5 B to 5 B. Installing tap off units on busway with different bus bar configurations will cause a loss of electrical continuity.
- Always use a properly rated voltage sensing device to confirm the tap off unit is off.

Failure to follow these instructions will result in death or serious injury.

DANGER

HAZARD OF ELECTRIC SHOCK, EXPLOSION, OR ARC FLASH

- The feed unit must be installed and serviced only by qualified electrical personnel.
- Do not remove any Metered Feed Unit compartment covers to complete the configuration tasks in this Operation Manual. The procedures in this document can be completed without removing compartment covers.
- Turning off the Metered Feed Unit's fused disconnect does not remove power from the busway run. Turning off the fused disconnect only removes power from the PM5350 Power Meter and EGX300 Gateway.

Failure to follow these instructions will result in death or serious injury.

Labels

Look for additional safety information affixed to hardware, in the form of safety labels. Follow all safety label instructions on equipment and inside this manual.

Tap Off Unit Nameplate

Powerbus

Busway Unit Unidad de Electroducto
Unité de Canalisation Préfabriquée

Refer to the instruction bulletin provided with the equipment for short circuit rating information, mounting instructions, and further marking information. If bulletin is lost, contact your local Schneider Electric office.

Consulte el boletín de instrucciones provisto con el equipo para obtener información acerca de los valores nominales de cortocircuito, instrucciones de montaje e información adicional sobre el marcado. Si ha extraviado el boletín, pongase en contacto con la oficina local de Schneider Electric.

Reportez vous aux directives d'utilisation, situées à l'intérieur du couvercle, pour obtenir la valeur nominale de court-circuit, les instructions de montage et les informations sur les autres marquages. Si les directives sont perdues, contactez votre bureau de ventes local Schneider Electric.

Top
Parte superior
Haut

CAT. N° / N°. DE CAT. / N° CAT. MAX. V / V MAX.
PBPQOD 4A 100CCCL515 240 VAC

MAX. A / A MAX.
15 A

SYS. / SISTEMA
3P4W

D.C. / S.N.

EAV15958

pdu0611a

Busway Nameplate

Powerbus

Busway Electroducto Canalisation

The short circuit rating (0.05 sec) is **35.000** rms symmetrical amperes, at maximum voltage. The short circuit rating is limited to the lowest short circuit rating of any busway or fitting installed. Nameplate ratings apply to all mounting positions.

El corto circuito nominal (0.05 seg) es **35.000** Amperes simétricos RMS, a máxima tensión. El corto circuito nominal es limitado al corto circuito nominal más bajo de cualquier electroducto o accesorio instalado. Datos de placa nominal aplican en todas las posiciones de montaje.

La valeur nominale de court-circuit (0,05 s) est de **35.000** ampères symétriques efficaces à la tension maximale. La valeur nominale de court-circuit est limitée à la valeur nominale de court-circuit la plus basse de tous les raccords ou canalisations préfabriquées installés. Les valeurs nominales sur la plaque signalétique s'appliquent à toutes les positions de montage.

Not suitable for vertical mounting/No es adecuado para montaje vertical/ Ne convient pas pour montage vertical

Maximum Support Intervals / Intervalos De Soporte / Intervalles De Support Maximal

Horizontal Mounting / Montaje Horizontal / Montage Horizontal
5 foot

Horizontal Mounting / Montaje Horizontal / Montage Horizontal
5 foot

Front / Frontal
Top
Parte superior
Haut

CAT. N° / N°. DE CAT. / N° CAT.
PBCE 4A 400ST120B

MAX. V / V MAX. 600 VAC

MAX. A / A MAX. 400 A

SYS. / SISTEMA 3P4W

NEUT. CAP. / CAP. NEUT.
100%

16

pdu0612a

iBusway for Data Center Metering Overview

Metering Connection

The iBusway for Data Center power distribution solution, which is based on the Powerbus™ plug-in bus bar system, provides row-level power monitoring through Metered Power Feed Units and rack-level power monitoring through Metered Tap Off units. The metered devices are equipped with a PowerLogic™ PM5350xB power meter, which monitors energy usage and features an LCD display for local access. The Metered Feed Units and EGX300 Gateway Tap Off Unit are equipped with a PowerLogic EGX300 Ethernet Gateway, which passes information between the Power Meter and StruxureWare™ Data Center Expert or a Web browser. With the EGX300 Ethernet Gateway and one or more PM5350xB Power Meters, the iBusway for Data Center solution is network manageable, Modbus™ TCP/IP and Ethernet-enabled for remote monitoring, and compatible with StruxureWare Data Center Expert and StruxureWare Power Monitoring Expert.

NOTE: For systems using StruxureWare Power Monitoring Expert or StruxureWare Data Center Expert, see the documentation for your StruxureWare device to configure it to monitor the iBusway for Data Center solution.

Serial Modbus Daisy Chain

2-wire Devices: The EGX300 can be connected in a daisy chain with up to 32 PM5350xB Power Meters.

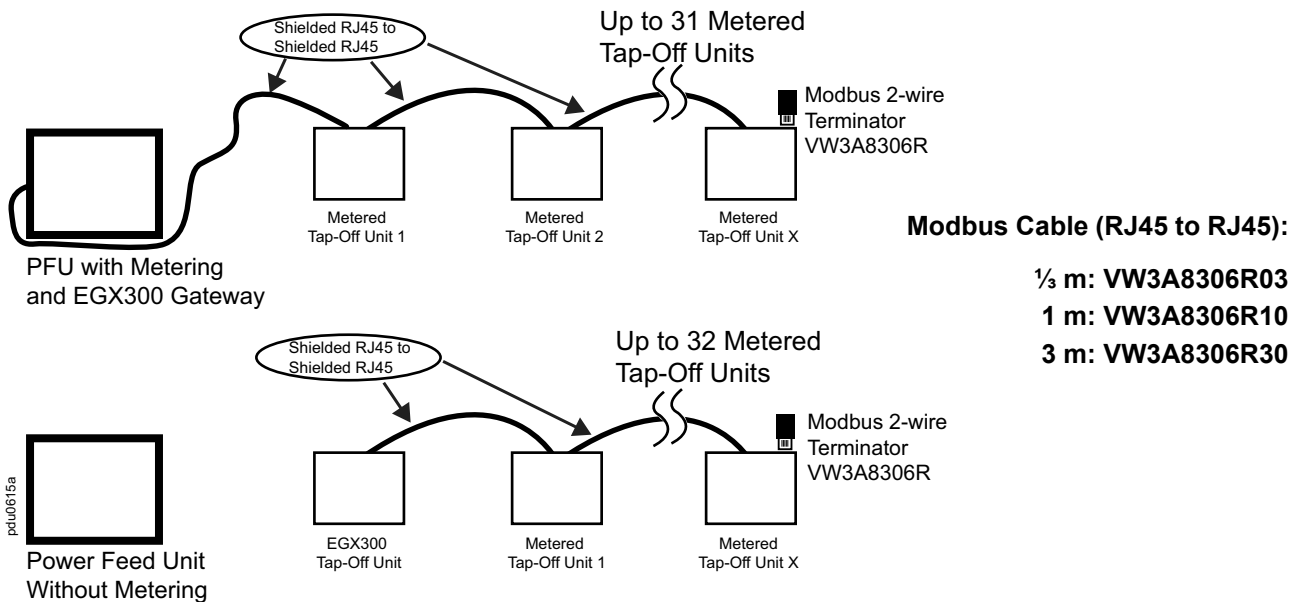

- The terminal's voltage and current ratings are compliant with the requirements of the EIA RS485 communications standard.
- Terminate the last RJ-45 Modbus outlet of the daisy-chain with the Modbus Terminator. For installations with a Metered Feed Unit but no metered tap off units, install the Modbus RJ-45 Terminator in the Feed Unit's Modbus port.
- Use only the RJ-45 Modbus 2-wire terminator (VW3A8306R) provided with the Metered Power Feed Unit or EGX300 Tap Off Unit.

NOTE: The number of PM5350xB Power Meters connected to one EGX300 could be reduced in order to improve the performance of the system.

Power Meter (PM5350xB)

PM5350xB Communication Setup

To begin power meter communication setup:

1. Scroll to “Maint” in the menu list by pressing the rightmost arrow SCROLL button (▶).
2. Press the “Maint” soft key.
3. Press the “Setup” soft key.
4. Enter your setup password, then press OK.
NOTE: the default password is 0000.
5. Press “Comm”. The Comms Setup screen appears.

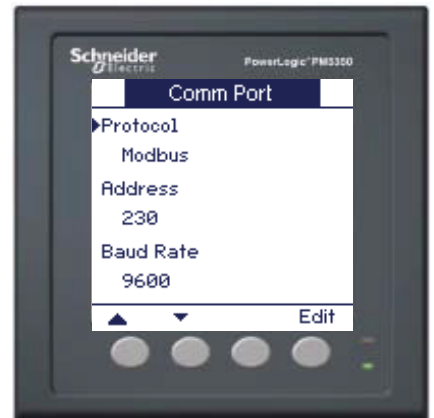

Setting Up the Modbus Address

To set up the Modbus address:

1. Press ▼ to select Address, then press (Edit).
2. Press + to increment the active digit through the numerals 0-9.
3. Press ◀ to enter the selected value for the active digit and move to the next digit to the left.
4. Continue until all values are selected, then press (OK) to set the address.

– For all PM5350xB Power Meters, the default communication parameters are:

- Modbus Address #1
- Baud rate: 19200
- Parity: Even
- Protocol: Modbus

NOTE: Each PM5350xB Power Meter in the daisy chain must have a unique address, including the meter in the Metered Power Feed Unit. All other communication parameters must match.

5. Press ▲ to exit Comm Port setup screen.
6. If changes have been made, a confirmation screen will prompt:
 - Press [Yes] to Save Changes
 - Press [No] to Discard Changes

Power Feed Unit / EGX Tap Off Unit

EGX300 Configuration

Ethernet Configuration

Before configuring the EGX, obtain a unique static IP address, subnet mask, and default gateway address from your network administrator. Use a Web browser to configure the EGX with the information obtained from your network administrator.

Ethernet Setup Using a Web Browser

1. Disconnect your computer from your network.

NOTE: After disconnecting from your network, your computer should automatically use the default IP address 169.254.###.### (### = 0 to 255) and the default subnet mask 255.255.0.0. If the IP address is not automatically configured, contact your network administrator to set up a static IP address.

2. Use an Ethernet crossover cable to connect your computer to the Ethernet jack on the Metered Power Feed Unit or the EGX300 Tap Off Unit



The EGX300 arrives from the factory with default parameters:

IP: 169.254.0.10
User name: Administrator
Password: Gateway

3. Once connected to the EGX300, go to the Setup page to continue configuring the EGX300.

Set Up the Device List

To set up the Device List for the EGX:

1. Click Setup in the top menu bar.
2. Click Device List in the left navigation menu.
3. Select the number of viewable devices (1 to 32). The default number of devices is eight.
4. For each attached device on the daisy chain, enter the Local ID and Device Name. Select the Device Type "PM5350xB" from the drop-down menu.
5. Click Apply.

NOTE: The Power Meter must have a Modbus address before it can be added to the device list. See "Setting Up the Modbus Address" on page 5 for more information.

Device Discovery

To automatically discover Metered Power Feed Units and Metered Tap Off Units and add them to the EGX300 device list:

1. Click Setup in the top menu bar.
2. Click Device List in the left navigation menu.
3. Click Discover at the bottom of the page.
4. Enter the Modbus address range to scan.
5. Click Start Discover.

NOTE: The Discover feature can also be used as a diagnostic tool to verify correct configuration of devices, once all devices have been initially configured.

NOTE: The Power Meters must have a Modbus address before they can be auto-discovered and added to the device list. See “Setting Up the Modbus Address” on page 5 for more information.

Configure EGX300 IP address

When you finish making configuration changes to the EGX300, assign its IP address.

1. Click Setup in the top menu bar. By default, the left navigation menu option “Ethernet & TCP/IP” is selected.
2. Enter the static IP address, Subnet Mask, and Default Gateway the network administrator provided you.
3. Click Apply.

NOTICE
LOSS OF CONNECTIVITY
Record the new network settings and save them for future reference.
Failure to record and save the new network settings will result in loss of access to the system.

NOTE: To recover lost network settings, the TCSEAK0100 Configuration Kit is required. See the EGX300 Installation Guide on www.schneider-electric.com for more information.

4. Log out of the EGX300 interface.

Configure the Date and Time

You can set the date and time of the EGX300, and the Power Meters it is monitoring, at the EGX300 Web interface.

Set the date and time of the EGX300 Ethernet Gateway

1. Click Setup in the top menu bar.
2. Select Date and Time in the left navigation menu.
3. Mark the Enable Network Time Synchronization check box or enter the date and time and click Apply.

Reset the date and time of a Power Meter at the EGX300 Web interface:

1. Select Control in the top menu bar.
2. Select the device to modify.
3. Mark the Date/Time check box and click Reset.

Set the date and time of the Power Meter at its LCD interface

1. Scroll to [Maint] in the menu list.
2. Press [Maint].
3. Press [Setup].
4. Enter your setup password.
NOTE: The default password is 0000.
5. Press [Clock]. The Clock setup screen appears.
6. Press [Edit] to select Date.
7. Press + to increment the active digit for the first character of the date.
8. Press ◀ to enter the selected character and move to the character to the left.
9. Continue until all values are selected, then press [OK] to set the date.
10. A confirmation screen will prompt:
 - Press [Yes] to Save Changes
 - Press [No] to Discard Changes
11. Press ▼ and follow Steps 7 to 9 to set the Time.
12. Press ▼ to select Meter Time, then press [Edit].
13. Press + and - to scroll through the meter time options.
14. Press [OK] to set the meter time.

The power meter stores all date and time stamps in GMT. If "Local" meter time is selected, the GMT offset converts the GMT values to local date and time values for display on the display. There is also an option to display the GMT values on the display.

Reset Device Parameters

At startup, a global reset is recommended. The reset can be performed at the power meter's LCD display or from the EGX300 Web interface.

Reset the Power Meter from the EGX300 Web interface

1. Select Control in the top menu bar.
2. In the left navigation menu, select the device to reset.
3. Mark the check box of each parameter to reset, then click Reset.

Reset the Power Meter from its LCD interface

1. Scroll to [Maint] in the menu list.
2. Press [Maint].
3. Press [Reset]. The Resets screen appears.
4. Press [Select] to select Global Resets.
5. Press [Reset] to select Meter Initialization.

NOTICE

SYSTEM DATA LOSS

The Meter Initialization option clears metering data (energy, demand, minimum/maximum values, counters, logs, timers, and input metering data).

The Global Reset option will cause permanent loss of PM5350xB Power Meter metering data.

6. Enter the Energy Password (**0000** by default), then press [OK].
7. A confirmation screen will prompt:
 - Press [Yes] to reset the power meter.
 - Press [No] to return to the previous screen.

Reset Passwords

Reset the Power Meter passwords

You can configure the Power Meter passwords. The passwords must use four numeric characters.

NOTICE
LOSS OF METER ACCESS
Record the new passwords and save them for future reference.
Failure to record and save the new passwords will result in loss of access to the Power Meter.

1. Press ▼ and ▲ to scroll through the passwords in the Passwords screen.
2. Press [Edit] to select a password.
3. Press + to increment the active digit through the numerals 0-9.
4. Press ◀ to enter the selected value for the active digit and move to the next digit to the left.
5. Continue until all values are selected, then press [OK] to set the password.
6. A confirmation screen will prompt:
 - Press [Yes] to Save Changes
 - Press [No] to Discard Changes

Reset the EGX300 password

You can configure the EGX300 passwords. User names and passwords are case-sensitive and can contain only alphanumeric characters.

NOTICE
LOSS OF CONNECTIVITY
Record the new passwords and save them for future reference.
Failure to record and save the new passwords will result in loss of access to the iBusway for Data Center system.

1. Select Setup in the top navigation menu.
2. Select User Accounts in the left navigation menu.
3. Enter a new Administrator password (0-12 characters), then click Apply.

NOTE: For more information about user accounts, see the PowerLogic Ethernet Gateway EGX300 User Guide, available on www.schneider-electric.com.

Worldwide Customer Support

Customer support for this or any other product is available at no charge in any of the following ways:

- Visit the Schneider Electric Web site to access documents in the Schneider Electric Knowledge Base and to submit customer support requests.
 - **www.schneider-electric.com** (Corporate Headquarters)
Connect to localized Schneider Electric Web sites for specific countries, each of which provides customer support information.
 - **www.schneider-electric.com/support/**
Global support searching Schneider Electric Knowledge Base and using e-support.
- Contact the Schneider Electric Customer Support Center by telephone or e-mail.
 - Local, country-specific centers: go to **www.schneider-electric.com > Support > Operations around the world** for contact information.

For information on how to obtain local customer support, contact the representative or other distributors from whom you purchased your product.

Customer support and warranty information is available at **www.apc.com**.

© 2014 Schneider Electric. All Rights Reserved. Schneider Electric is a trademark owned by Schneider Electric Industries SAS or its affiliated companies. All other trademarks are the property of their respective owners.