

Assembly Instructions

⚠ Important ⚠

Before you begin, read and comply with all safety and operating instructions, and ensure all parts and correct quantities are included.

Any parts damaged during shipment must be reported within 5 days of receipt. To report information regarding missing parts or damage, to purchase parts or accessories, or if you have any questions, please contact us.

www.spectrumfurniture.com
800-235-1262, 715-723-6750

Thank you for purchasing Spectrum products!

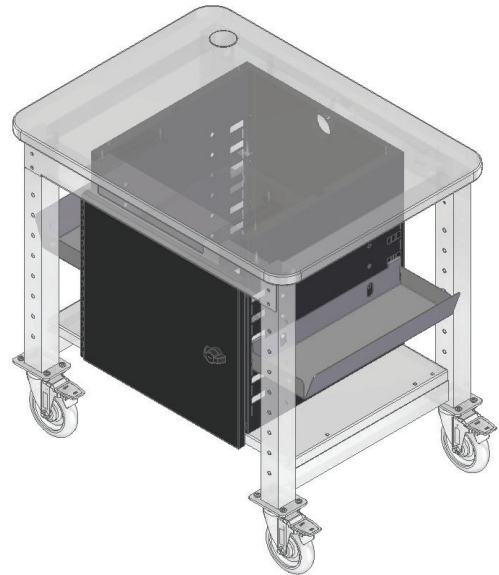

Locking Cabinet for 3D2GO™ Printer Cart 37135

Note: The Locking Cabinet is not compatible with the 37136 Adjustable Shelf.

Tools
Required



Phillips
Screwdriver

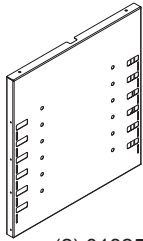

(2) 013250
Side panel

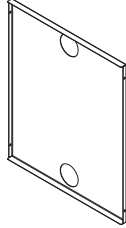

(1) 0134807
Back panel

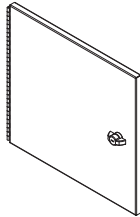

(1) 0135328
Door assembly

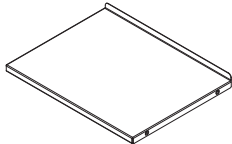

(1) 0134837
Internal shelf

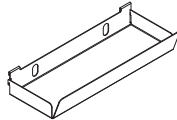

(2) 0135232
Side bin



(2) 0119468
Recessed bumper
with washer

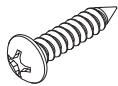

(4) 026073
#8 x 3/4" PHSM

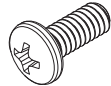

(4) 026064
1/4-20 x 5/8" PHM



(14) 0190174
#8 x 3/8" PHSM



(2) 059984
2" Grommet

1. Assemble cabinet

1. Attach the side panels to the rear panel with (4) #8 x 3/8" PHSM screws. **Figure 1.1.**

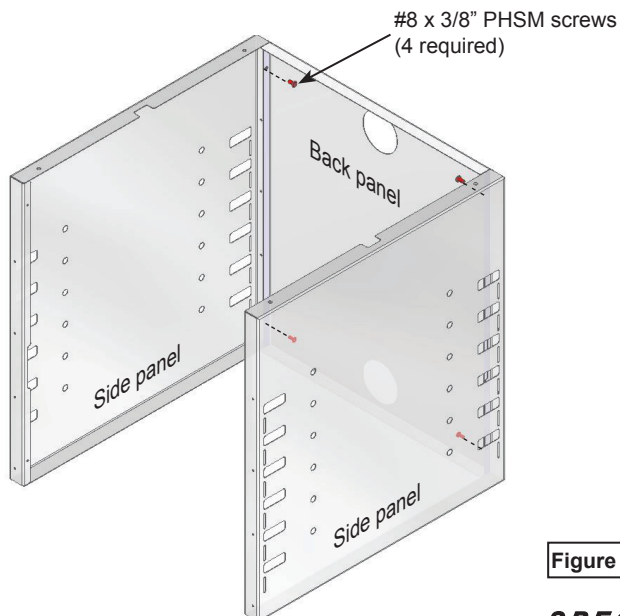

Figure 1.1

2. Install (2) 2" grommets in the back panel. **Figure 1.2.**

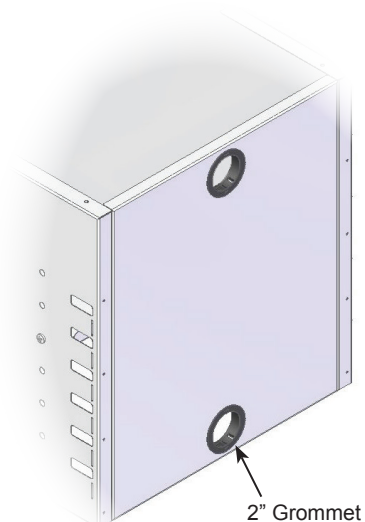

Figure 1.2

2. Install cabinet to cart

1. Carefully flip the cart upside-down onto a non-abrasive surface. This may require two people.
2. Set the cabinet onto the worksurface underside and align with the mounting holes. **Figure 2.1.**
3. Secure the cabinet to the worksurface with (4) #8 x 3/4" PHSM screws and tighten securely.
4. Attach the (2) recessed bumpers to the side opposite the preferred hinge-side as shown using (2) #8 x 3/8" PHSM screws.

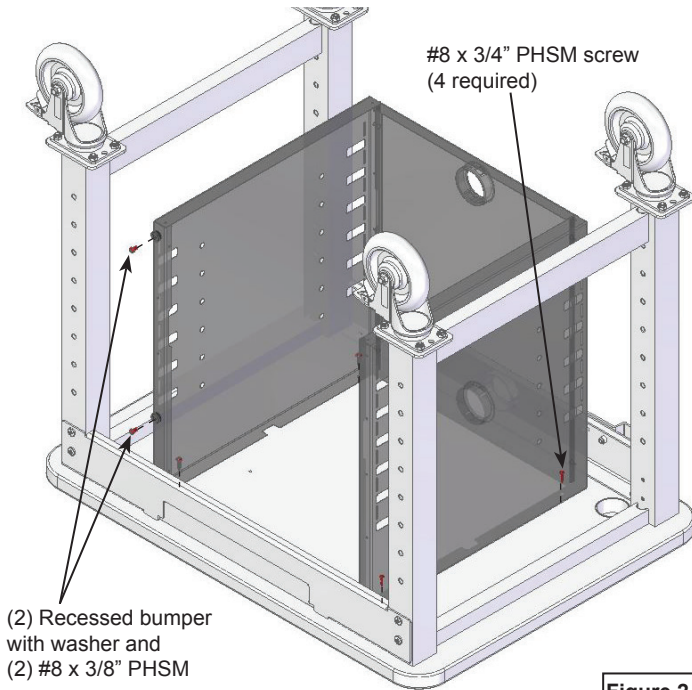

Figure 2.1

Note: The cabinet should be installed with the cart flipped upside-down. To provide clearance to install the cabinet, the bottom panel should not be installed. If this panel is installed, please remove screws and set panel aside.

5. Slide the bottom panel (bends facing wheels) into place and attach to the legs with the previously removed screws. **Figure 2.2.**
6. Install (4) #8 x 3/8" PHSM screws into the cabinet to secure.

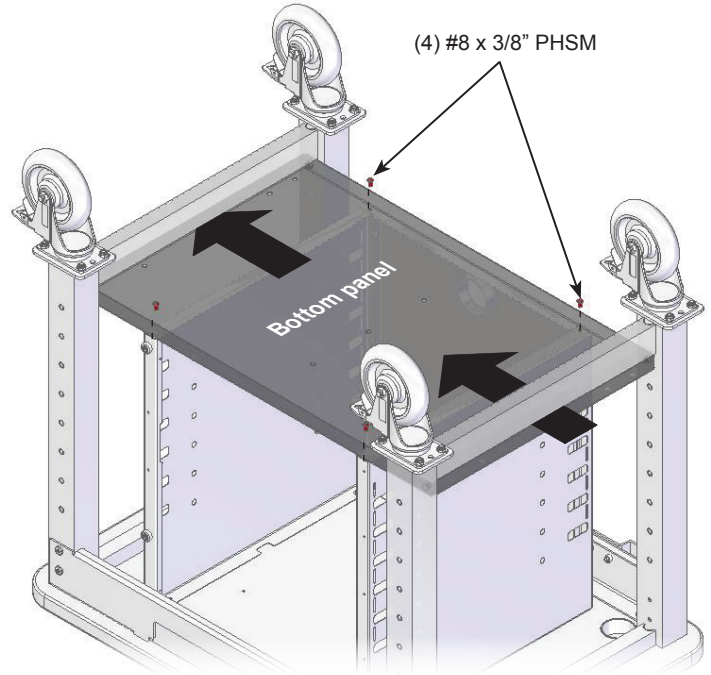

Figure 2.2

7. Tip the internal adjustable shelf at 45° and insert into the cabinet. **Figure 2.3.** Note: The flat side of the shelf will face the bottom of the worksurface.
8. Align and attach the shelf at the desired height using (4) 1/4-20 x 5/8" PHM screws.

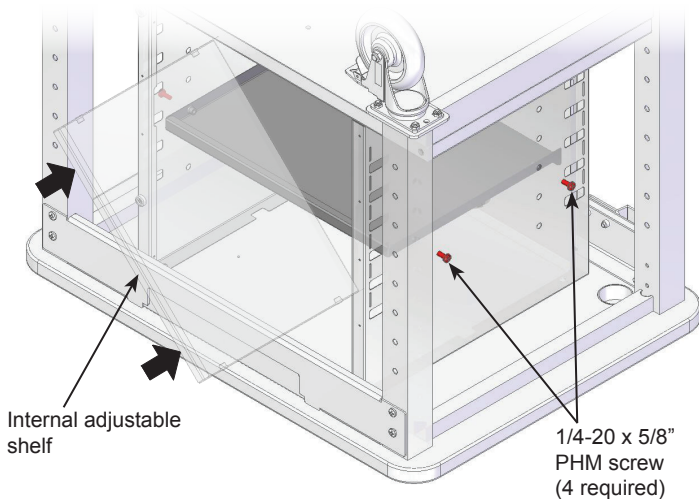

Figure 2.3

3. Install door

1. Carefully flip the cart back upright. **Figure 3.**
2. Align the door assembly hinge with the mounting holes in the cabinet and attach with (4) #8 x 3/8" PHSM screws. Tighten securely.
3. Install external bins at desired height. (Not shown).

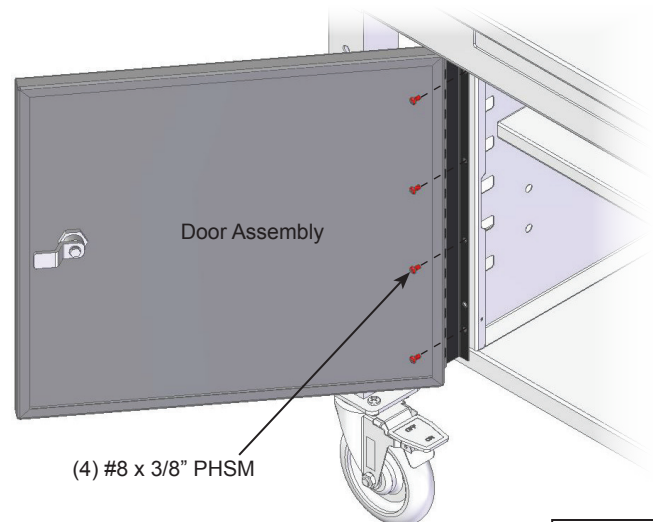

Figure 3